



NEW

REIBSYSTEM DR large

Modulares Reiben für große Bohrungsdurchmesser bis 200 mm

REAMING SYSTEM DR large

Modular reaming for bore diameters up to 200 mm

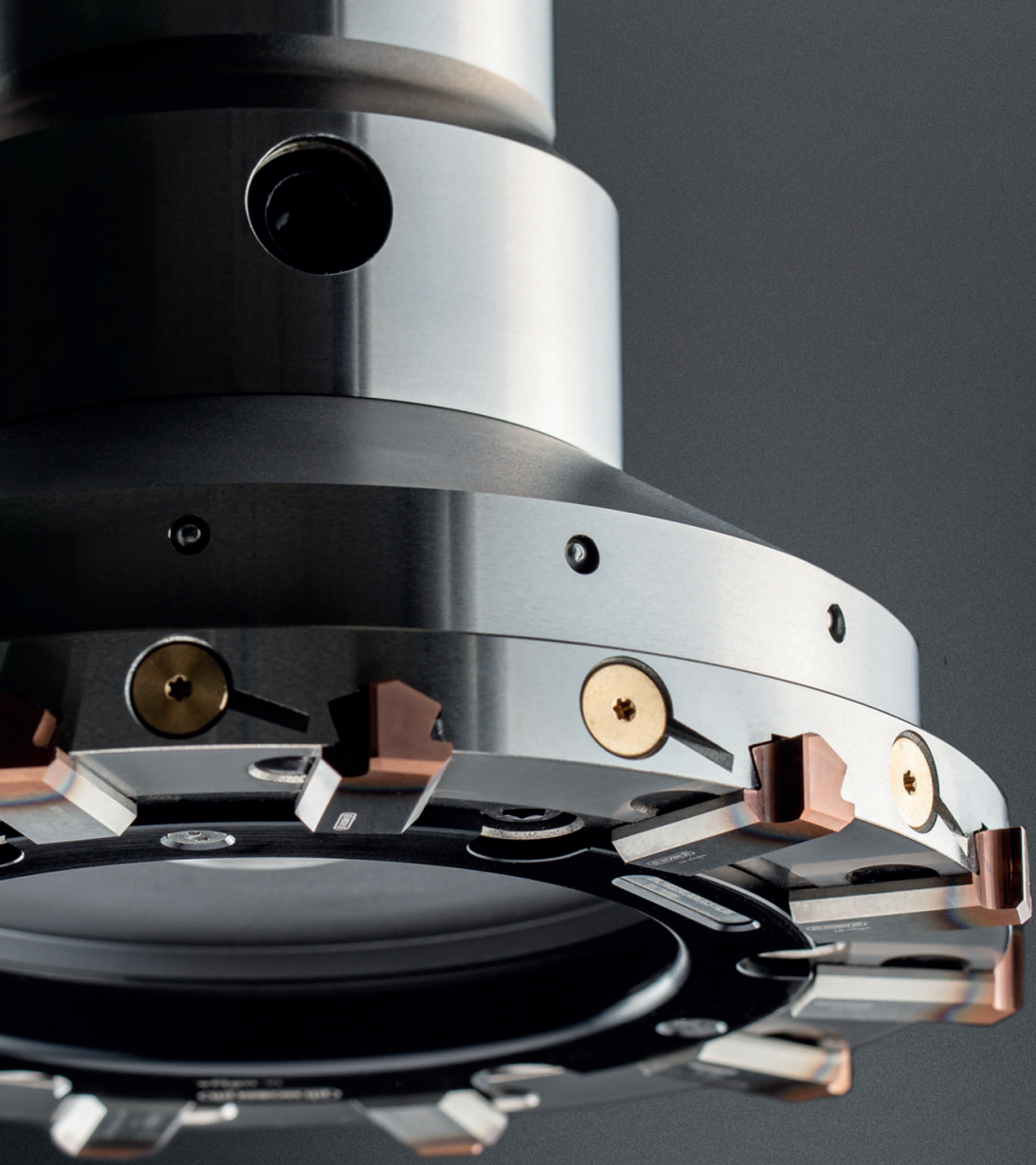

DER UNTERSCHIED: MEHR MÖGLICHKEITEN

THE DIFFERENCE:
MORE POSSIBILITIES

- **Einfaches Rüsten und Wechseln
des Schneidrads ohne Werkzeug-
einstellung**

Simple set-up and exchanging of
the reaming head without tool
adjustment

- **Modularer Systemaufbau mit
einer Vielzahl an Standard-
schneideinsätzen**

Modular system design with a
wide range of standard inserts

- **Kostengünstiger Service für
die Schneidräder durch HORN**

Inexpensive servicing of the
reaming heads by HORN

Systemgröße DR150 - DR200

System Size DR150 - DR200



Modulares System für Ø 139,8 - 202,2 mm

Modular System for Ø 139.8 - 202.2 mm

Systemaufnahmen / System adapter Beta-Modul

Ausgleichshalter / Balancing shank

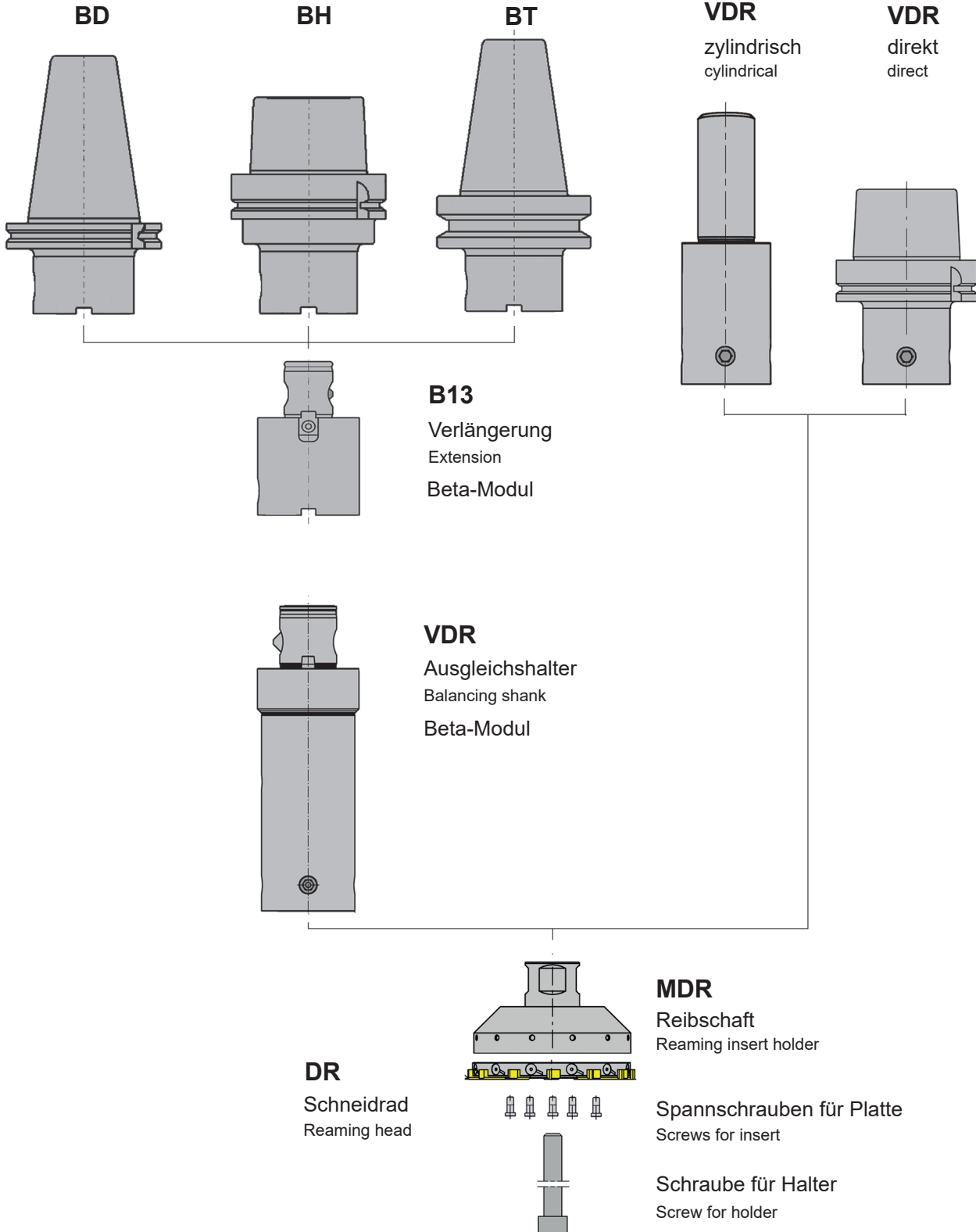

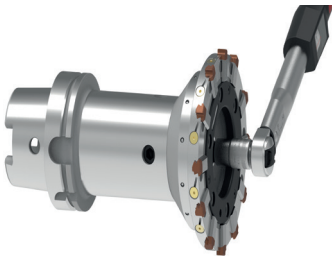

1. Werkzeugzusammenbau
Assemble the tool

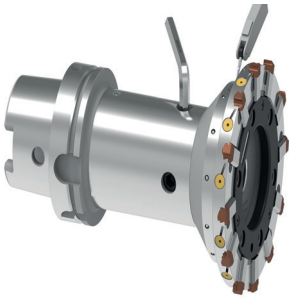

2. Rundlauf einstellen
Adjust run-out

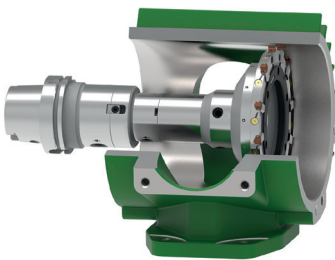

3. Werkzeug im Einsatz
Tool in use

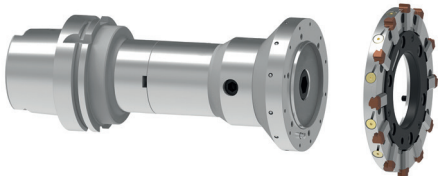

4. Nach Standzeitende gebrauchte
Schneide demontieren
After tool life end disassemble used
reaming head.



5. Montage neues Schneidrad
Assembly new reaming head

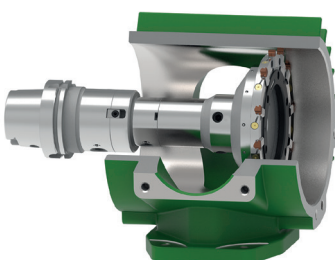

6. Werkzeug im Einsatz
Tool in use



Anforderungen

- Präzision
- Prozesssicherheit
- Einfaches Handling
- Produktivität

Requirements

- Precision
- Process reliability
- Simple handling
- Productivity

Anwendungsbeispiel „Planetenträger“

Material: EN-GJS 400

Example of a „Planet Carrier“ Application

Material: EN-GJS 400

Schnittdaten

Cutting Data

v_c	125 m/min
f_z	0,20 mm
z	12
v_f	530 mm/min
a_p	0,15 mm
\varnothing	180 N6 mm
L	2x120 mm
XS	650 mm

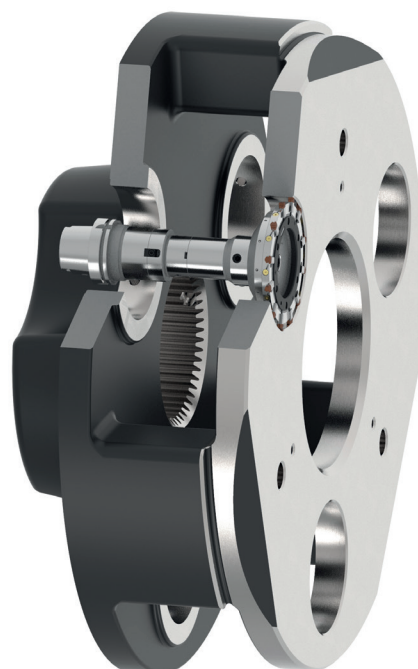

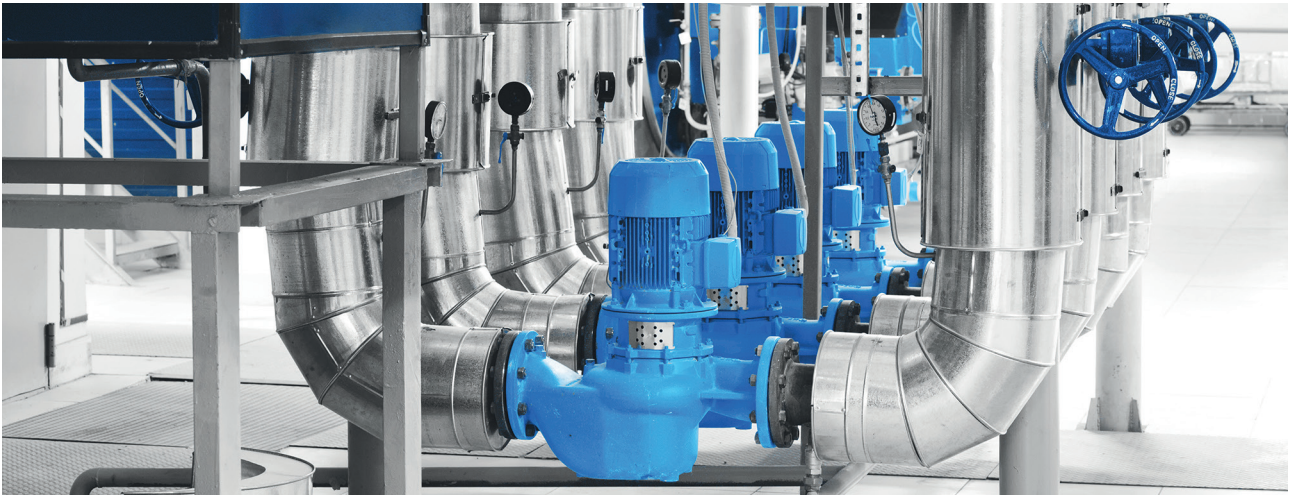

Anforderungen

- Präzision
- Prozesssicherheit
- Tiefe Kosten
- Einfaches Handling

Requirements

- Precision
- Process reliability
- Low costs
- Simple handling

Anwendungsbeispiel „Pumpengehäuse“

Material: GG25

Example of a „Pump Housing“ Application

Material: GG25

Schnittdaten

Cutting Data

v_c	100 m/min
f_z	0,15 mm
z	12
v_f	353 mm/min
a_p	0,15 mm
\varnothing	162 H8 mm
L	300 mm
Ra	1,2 μ m
XS	350 mm

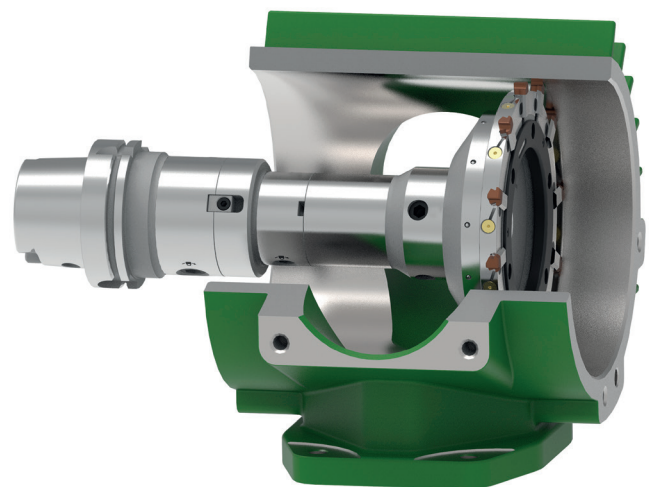

Bestellbeispiel mit Festmaß

Ordering example with fixed dimension

DR.150033.G16.L.2 HL3M (N)

DR

DR Systembezeichnung

DR System designation

150,033

Durchmesser in mm

Diameter in mm

G16

Schneidengeometrie (weitere Geometrien siehe „Standard Schneidräder“)

Cutting geometry (for more geometries see „Standard Reaming head“)

L

Verzahnungsrichtung (G = gerade, L = linksschräg)

Helix angle (G = straight, L = left-hand helix)

2

Schneidkantenverrundung (weitere Ausführungen siehe unten)

Cutting edge preparation (for more versions see below)

HL3

Beschichtung (weitere Beschichtungen siehe „Standard Schneidräder“)

Coating (for more coatings see „Standard Reaming head“)

M

Hartmetallsubstrat

Carbide substrate

(N)

Freilassung für Aufbereitung (N)

Left out for reprocessing

Weitere Schneidkantenverrundungen

More cutting edge preparations

S

ohne Schneidkantenverrundung

without cutting edge preparation

2

mittlere Schneidkantenverrundung

medium cutting edge preparation

3

stärkere Schneidkantenverrundung

larger cutting edge preparation

Bei Anfragen mit Angaben der Bohrungstoleranz wird der Schneidringdurchmesser durch den HORN-Standard definiert. Der Schneidringdurchmesser liegt je nach Größe der Toleranz bei 65% bis 80% des Bohrungstoleranzfeldes.

Der durch den HORN-Standard festgelegte Durchmesser wird immer als Festmaß ausgewiesen.

Beispiel 1:

Anfrage mit ISO Bohrungstoleranz:
Durchmesser: 160H7 Festmaß

Durchmesser nach HORN-Standard:
Durchmesser: 160,033 mm

Schneidringbezeichnung:
DR.160033.A01.L.S HL3M

Beispiel 2:

Anfrage mit Bohrungstoleranz:
Durchmesser: 185 +0,030 -0,015 mm

Festmaßdurchmesser nach HORN-Standard:
Durchmesser: 185,021 mm

Schneidringbezeichnung:
DR.185021.C01.G.S AN4M

Beispiel 3:

Anfrage mit definiertem Schneidringmaß
Durchmesser: 193,158 mm

Festmaß Durchmesser nach HORN-Standard:
Durchmesser: 193,158 mm

Schneidringbezeichnung:
DR.193158.B06.L.S HL3M

Das Fertigungsmaß des Schneidrings
beträgt immer +/-0,003 mm

For requests with specifications of the bore tolerance, the reaming head diameter is defined by the HORN standard. Depending on the diameter and the tolerance range, the reaming head diameter will be within 65% to 80% of the total bore tolerance range.

The diameter specified by the HORN standard is always shown as a target size dimension.

Example 1:

Request with ISO bore tolerance
Diameter: 160H7

Target size diameter according to HORN
standard: Diameter: 160,033 mm

Reaming head part number:
DR.160033.A01.L.S HL3M

Example 2:

Request with bore tolerance
Diameter: 185 +0,030 -0,015 mm

Target size diameter according HORN
standard: Diameter: 185,021 mm

Reaming head part number:
DR.185021.C01.G.S AN4M

Example 3:

Request with reaming head target size
Diameter: 193,158 mm

Target size diameter according HORN-
standard: Diameter: 193,158 mm

Reaming head part number:
DR.193158.B06.L.S HL3M

The reaming head manufacturing tolerance
is always +/-0,003 mm

1.

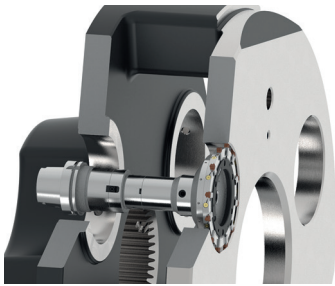

1. Werkzeug im Einsatz. Nach Standzeitende kann der Schneidring zur Aufbereitung an HORN zurückgeschickt werden.

Tool in use. After tool life ends, the reaming head can be returned to HORN for reconditioning.

2. a) Schneidring kann auf gleichen Durchmesser und Geometrie aufbereitet werden.
b) Schneidring kann auf andere Durchmesser und/oder Geometrie aufbereitet werden.

2. a) Reaming head can be reconditioned to same size and geometry.
b) Reaming head can be reconditioned to other size and/or geometry.

2.
a)



b)

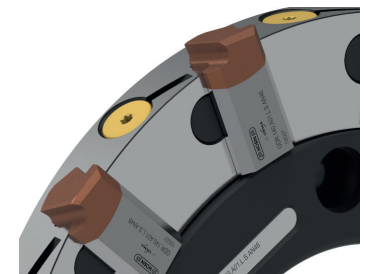

3.
a)

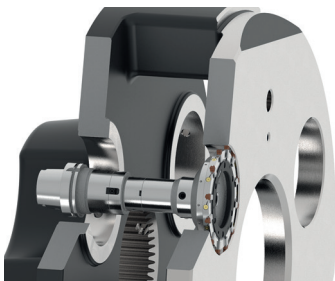

3. a) Werkzeug in der gleichen Bohrung einsetzen.
b) Werkzeug in einer anderen Bohrung einsetzen.

b)

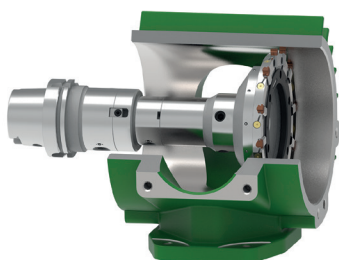

3. a) Use tool in the same bore.
b) Use tool in a different bore.

Standard Schneidräder

Standard Reaming heads



Der Schneidendurchmesser kann durch die Vervollständigung der Bestellnummer frei bestimmt werden.

Schnittparameter erhalten Sie auf Anfrage.

The cutting edge diameter can be freely determined by completing the part number.
Cutting data available upon request

Gerade verzahnte Schneidräder - für Sacklochbohrungen und teilweise für Durchgangsbohrungen

straight fluted reaming heads -
for blind holes and partly for through holes

Bestellnummer Part number	Anschnittwinkel Firstcut angle	Verrundung Preparation	Verjüngung Backtaper	P	M	K	N
DR. _____ A06.G.S HL3M	45°	-	x2	•	•	○	
DR. _____ G16.G.S HL3M	60°/43°	-	x2	•	•	○	
DR. _____ C16.G.S HL3M	45°/20°	-	x2	○	•	○	
DR. _____ A06.G.2 HL3M	45°	2	x2	○		•	
DR. _____ G16.G.2 HL3M	60°/43°	2	x2	○		•	
DR. _____ C16.G.2 HL3M	45°/20°	2	x2	○		•	
DR. _____ A01.G.3 AN4M	45°	3	x1	○		•	
DR. _____ C11.G.3 AN4M	45°/20°	3	x1	○		•	
DR. _____ C16.G.S NP1M	45°/20°	-	x2				•

Im kurzspanenden Werkstoff auch für Durchgangsbohrungen geeignet.
In short chipping material also suitable for through holes.

Linksschräg verzahnte Schneidräder - für Durchgangsbohrungen

left hand fluted reaming heads -
for through holes

Bestellnummer Part number	Anschnittwinkel Firstcut angle	Verrundung Preparation	Verjüngung Backtaper	P	M	K	N
DR. _____ C16.L.S HL3M	45°/20°	-	x2	•	•	○	
DR. _____ B06.L.S HL3M	25°	-	x2	•	•	○	
DR. _____ C16.L.2 HL3M	45°/20°	2	x2	○		•	
DR. _____ B06.L.2 HL3M	25°	2	x2	○		•	
DR. _____ A06.L.S HL3M	45°	-	x2	•	•	○	
DR. _____ C16.L.S NP1M	45°/20°	-	x2				•

Hochleistungsreiben DR large

High-Performance Reaming DR large



Schneidrad

Reaming head

DR large

gerade verzahnt
straight fluted

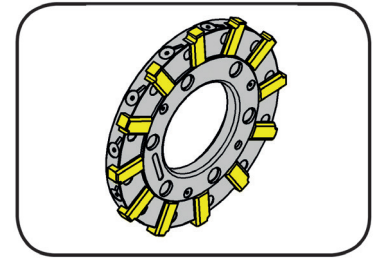

Schneidkreis-Ø Cutting edge Ø 139,801-200,2 mm

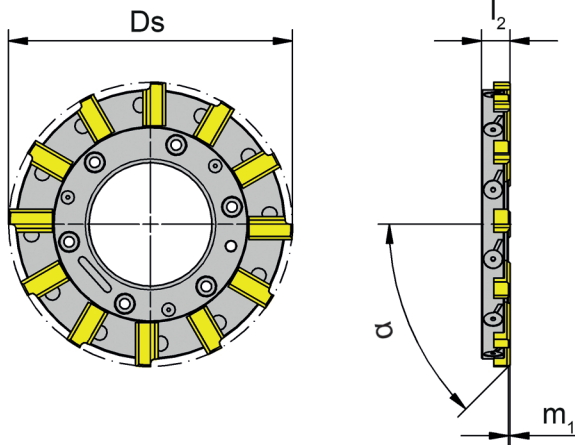

für Reibschaft
for Reaming insert holder

Typ MDR large
Type

mit innerer
Kühlmittelzufuhr
with through coolant supply

Abbildung = rechtsschneidend
Picture = right hand cutting version

Bestellnummer Part number	Ds	Ds _{min}	Ds _{max}	Größe Size	m ₁	α	l ₂	Z	HL3M
DR.140033.A06.G.S	140,033	139,801	149,8	150	0,85	45°	15	12	Δ
DR.150033.A06.G.S	150,033	149,801	159,8	160	0,85	45°	15	12	Δ
DR.160033.A06.G.S	160,033	159,801	169,8	170	0,85	45°	15	12	Δ
DR.170033.A06.G.S	170,033	169,801	179,8	180	0,85	45°	15	12	Δ
DR.180033.A06.G.S	180,033	179,801	189,8	190	0,85	45°	15	12	Δ
DR.190037.A06.G.S	190,037	189,801	200,2	200	0,85	45°	15	12	Δ
DR.200037.A06.G.S	200,037	189,801	200,2	200	0,85	45°	15	12	Δ

▲ ab Lager / on stock Δ 2 Wochen / 2 weeks x auf Anfrage / upon request

● empfohlen / recommended

o bedingt einsetzbar / alternative recommendation

- nicht geeignet / not suitable

■ unbeschichtete HM-Sorten / uncoated grades

■ beschichtete HM-Sorten / coated grades

■ bestückt/Cermet / brazed/Cermet

Abmessungen in mm

Dimensions in mm

P	•
M	•
K	o
N	-
S	-
H	-

HM-Sorten
Carbide grades

Hochleistungsreiben DR large

High-Performance Reaming DR large



Schneidrad

Reaming head

DR large

linksschräg verzahnt
left helical fluted

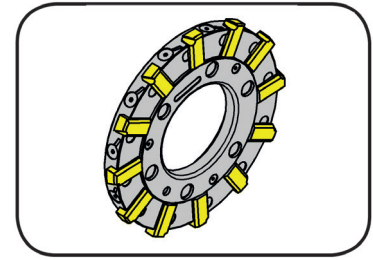

Schneidkreis-Ø Cutting edge Ø 139,801-200,2 mm

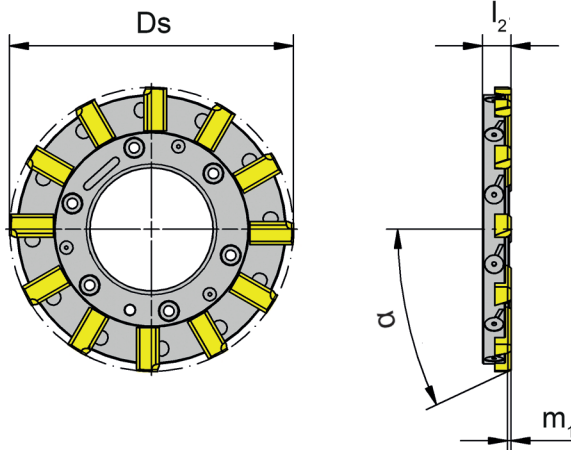

für Reibschaft
for Reaming insert holder

Typ MDR large
Type

mit innerer
Kühlmittelzufuhr
with through coolant supply

Abbildung = rechtsschneidend
Picture = right hand cutting version

Bestellnummer Part number	Ds	Ds _{min}	Ds _{max}	Größe Size	m ₁	α	l ₂	Z	HL3M
DR.140033.B06.L.S	140,033	139,801	149,8	150	1,82	25°	15	12	Δ
DR.150033.B06.L.S	150,033	149,801	159,8	160	1,82	25°	15	12	Δ
DR.160033.B06.L.S	160,033	159,801	169,8	170	1,82	25°	15	12	Δ
DR.170033.B06.L.S	170,033	169,801	179,8	180	1,82	25°	15	12	Δ
DR.180033.B06.L.S	180,033	179,801	189,8	190	1,82	25°	15	12	Δ
DR.190037.B06.L.S	190,037	189,801	200,2	200	1,82	25°	15	12	Δ
DR.200037.B06.L.S	200,037	189,801	200,2	200	1,82	25°	15	12	Δ

▲ ab Lager / on stock Δ 2 Wochen / 2 weeks x auf Anfrage / upon request

● empfohlen / recommended

o bedingt einsetzbar / alternative recommendation

- nicht geeignet / not suitable

■ unbeschichtete HM-Sorten / uncoated grades

■ beschichtete HM-Sorten / coated grades

■ bestückt/Cermet / brazed/Cermet

Abmessungen in mm

Dimensions in mm

P	•
M	•
K	o
N	-
S	-
H	-

HM-Sorten
Carbide grades

Hochleistungsreiben DR large

High-Performance Reaming DR large



Reibschaft
Reaming insert holder

MDR large

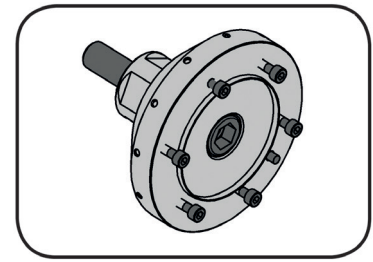

Schneidkreis-Ø	Cutting edge Ø	139,8 - 200,2 mm
----------------	----------------	------------------

mit integriertem Ausrichtmechanismus
with integrated compensation mechanism

für Schneidrad
for Reaming haed

Typ DR large
Type

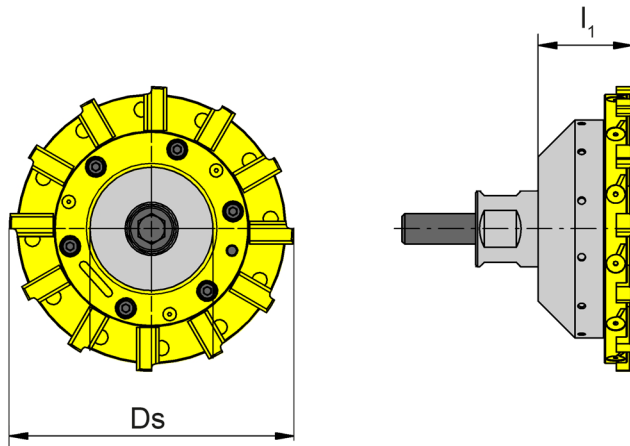

mit innerer
Kühlmittelzufuhr
with through coolant supply

Bestellnummer Part number	Ds _{min}	Ds _{max}	l ₁	Ds	Größe Size	Kühlung Coolant	Gewicht [kg] Weight [kg]
MDR.150.115.50.V.D	139,800	159,8	50	115	150/160	D	2,7
MDR.170.135.50.V.D	159,801	179,8	50	135	170/180	D	3,5
MDR.190.155.50.V.D	179,801	200,2	50	155	190/200	D	4,6

Abmessungen in mm
Dimensions in mm

Hochleistungsreiben DR large

High-Performance Reaming DR large



Schaft
Shank

VDR

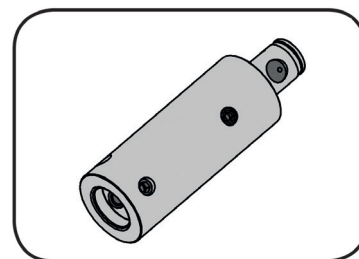

Schneidkreis-Ø	Cutting edge Ø	80,601 - 200,2 mm
----------------	----------------	-------------------

mit integriertem Ausrichtmechanismus
with integrated compensation mechanism

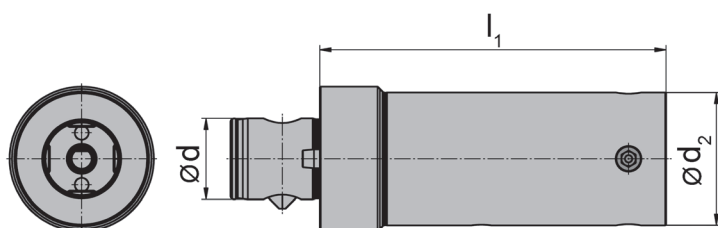

Form
BM = Beta-Modul

Bestellnummer Part number	Ds _{min}	Ds _{max}	l ₁	d	d ₂	Größe Size	Form Form
VDR.101.76.100.63.BM	80,601	200,2	100	63	76	101-200	BM
VDR.101.76.160.63.BM	80,601	200,2	160	63	76	101-200	BM

Abmessungen in mm
Dimensions in mm

Ersatzteile
Spare Parts

Schaft Shank	Schraube Screw
VDR.101...	C009016

Hochleistungsreiben DR large

High-Performance Reaming DR large



Schaft
Shank

VDR

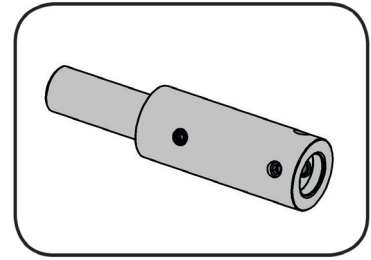

Schneidkreis-Ø	Cutting edge Ø	80,601 - 200,2 mm
----------------	----------------	-------------------

mit integriertem Ausrichtmechanismus
with integrated compensation mechanism

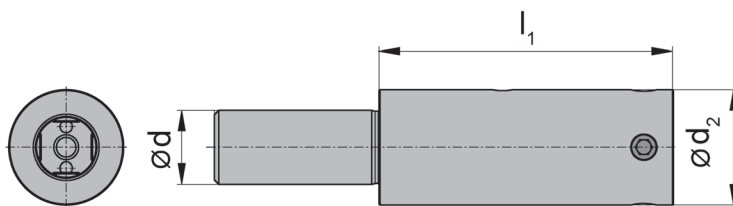

Form

- A = Zylinderschaft DIN 1835-A
Cylindrical shank
- B = Weldonschaft DIN 1835-B
Weldon shank DIN

Bestellnummer Part number	Ds _{min}	Ds _{max}	l ₁	d	d ₂	Größe Size	Form Form
VDR.101.76.100.40.A	80,601	200,2	100	40	76	101 - 200	A
VDR.101.76.100.40.B	80,601	200,2	100	40	76	101 - 200	B
VDR.101.76.160.40.A	80,601	200,2	160	40	76	101 - 200	A
VDR.101.76.160.40.B	80,601	200,2	160	40	76	101 - 200	B

Abmessungen in mm
Dimensions in mm

Ersatzteile
Spare Parts

Schaft Shank	Schraube Screw
VDR.101...	C009016

Hochleistungsreiben DR large

High-Performance Reaming DR large



Direktaufnahme

Direct mounting

VDR

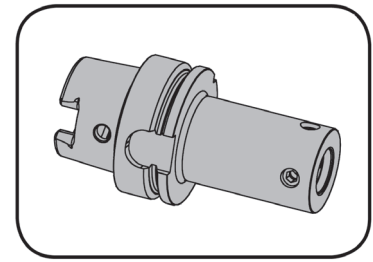

Schneidkreis-Ø Cutting edge Ø 80,601 - 200,2 mm

mit integriertem Ausrichtmechanismus
with integrated compensation mechanism

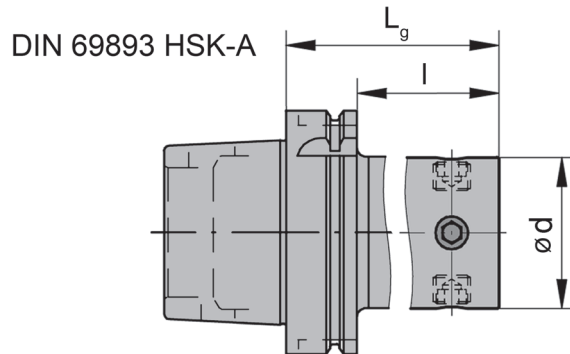

Bestellnummer Part number	Ds _{min}	Ds _{max}	l	Lg	d	Größe Size	System System	Gewicht [kg] Weight [kg]
VDR.101.120.A063	80,601	200,2	94	120	76	101 - 200	HSK63	2,4
VDR.101.130.A100	80,601	200,2	101	130	76	101 - 200	HSK100	5,0

Abmessungen in mm
Dimensions in mm

Ersatzteile

Spare Parts

Schaft Shank	Schraube Screw
VDR.101...	C009016

Hochleistungsreiben DR large

High-Performance Reaming DR large



Direktaufnahme
Direct mounting

VDR

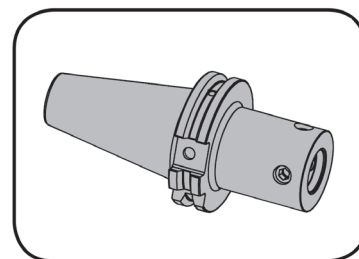

Schneidkreis-Ø Cutting edge Ø 80,601 - 200,2 mm

mit integriertem Ausrichtmechanismus
with integrated compensation mechanism

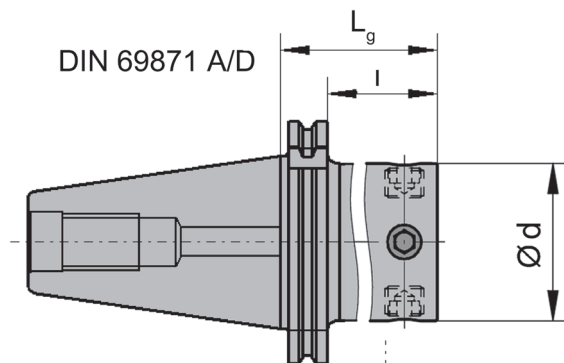

Bestellnummer Part number	Ds _{min}	Ds _{max}	l	Lg	d	Größe Size	System System	Gewicht [kg] Weight [kg]
VDR.101.095.40AD	80,601	200,2	76	95	76	101 - 200	SK 40	2,2
VDR.101.095.50AD	80,601	200,2	76	95	76	101 - 200	SK 50	4,6

Abmessungen in mm
Dimensions in mm

Ersatzteile
Spare Parts

Schaft Shank	Schraube Screw
VDR.101...	C009016

Hochleistungsreiben DR large

High-Performance Reaming DR large



Direktaufnahme

Direct mounting

VDR

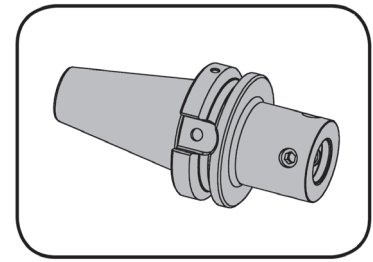

Schneidkreis-Ø	Cutting edge Ø	80,601 - 200,2 mm
----------------	----------------	-------------------

mit integriertem Ausrichtmechanismus
with integrated compensation mechanism

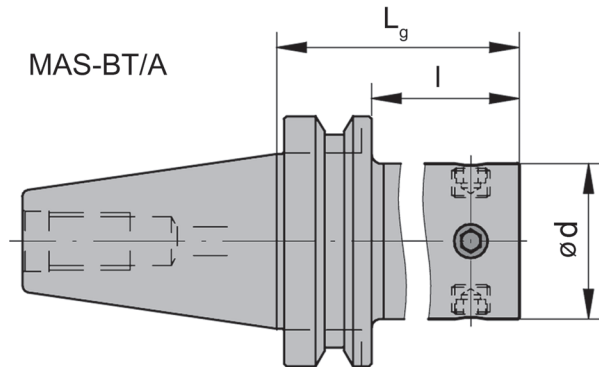

Bestellnummer Part number	Ds _{min}	Ds _{max}	l	Lg	d	Größe Size	System System	Gewicht [kg] Weight [kg]
VDR.101.095.40BT	80,601	200,2	-	95	76	101 - 200	JIS-BT 40	2,5
VDR.101.095.50BT	80,601	200,2	57	95	76	101 - 200	JIS-BT 50	5,1

Abmessungen in mm
Dimensions in mm

Ersatzteile

Spare Parts

Schaft Shank	Schraube Screw
VDR.101...	C009016

System-Aufnahme URMA **BH**

System Adaptors URMA



für Beta-Modul
for Beta-Modul

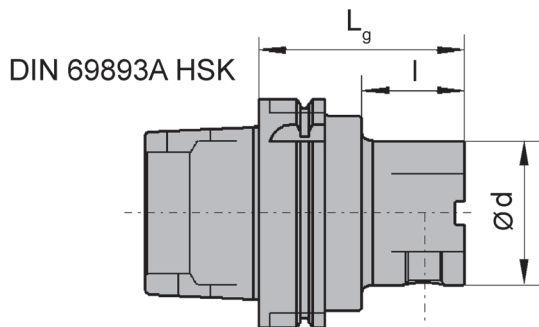

Bestellnummer Part number	L _g	l	d	Beta-Modul	Gewicht [kg] Weight [kg]	System System
BH10 63A 63 080	80	-	63	63	1,5	HSK-A 63
BH10 100A 63 080	80	35	63	63	3,3	HSK-A 100
BH10 100A 80 090	90	45	80	80	4,0	HSK-A 100
BH10 100A 100 100	100	-	100	100	5,0	HSK-A 100

Abmessungen in mm
Dimensions in mm

Bestellhinweis:

Das Kühlmittelrohr ist nicht im Lieferumfang enthalten - bitte separat bestellen!

Ordering note:

Coolant tube is not included - separate order required!

System-Aufnahme URMA **BD**

System Adaptors URMA



für Beta-Module
for Beta-Modul

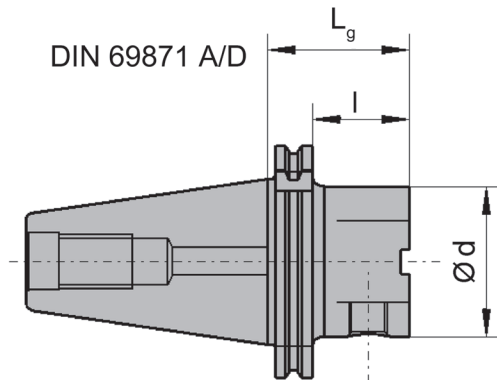

Bestellnummer Part number	Lg	l	d	Beta-Modul	Gewicht [kg] Weight [kg]	System System
BD10 40A 63 065	65	46	63	63	1,5	SK 40
BD10 40A 63 090	90	70	63	63	2,0	SK 40
BD10 50A 63 060	60	41	63	63	3,3	SK 50

Abmessungen in mm
Dimensions in mm

System-Aufnahme URMA **BT**

System Adaptors URMA



für Beta-Modul
for Beta-Modul

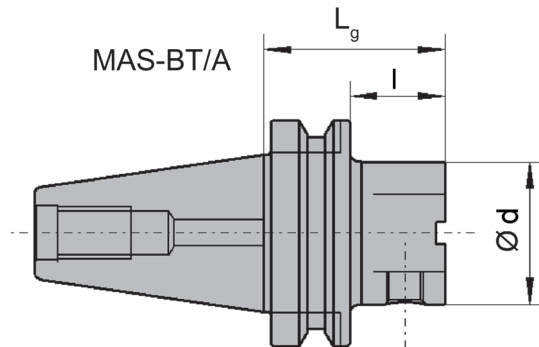

Bestellnummer Part number	L_g	l	d	Beta-Modul	Gewicht [kg] Weight [kg]	System System
BT10 40A 63 055	55	28	63	63	1,4	JIS-BT 40
BT10 40A 63 070	70	43	63	63	1,7	JIS-BT 40
BT10 50A 63 080	80	42	63	63	4,3	JIS-BT 50

Abmessungen in mm
Dimensions in mm

Verlängerung
Extension

B13



für Beta-Modul
for Beta-Modul

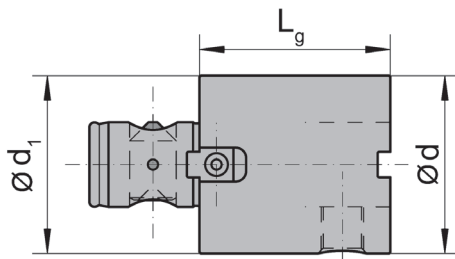

Bestellnummer Part number	Lg	d	d ₁	Schnittstelle maschinenseitig Interface machine end	Schnittstelle schneidenseitig Interface cutting edge end	Gewicht [kg] Weight [kg]
B13 63 63 060	60	63	63	63	63	1,3
B13 63 63 125	125	63	63	63	63	2,9

Abmessungen in mm
Dimensions in mm



**FINDEN SIE JETZT IHRE
PASSENDE WERKZEUGLÖSUNG.**

FIND YOUR RIGHT
TOOLING SOLUTION NOW.

www.PHorn.de

DEUTSCHLAND, STAMMSITZ

GERMANY, HEADQUARTERS

—

Hartmetall Werkzeugfabrik

Paul Horn GmbH

Horn-Straße 1

D-72072 Tübingen

Tel +49 7071 / 70040

Fax +49 7071 / 72893

info@PHorn.de

www.PHorn.de

Find your country:

www.PHorn.com/countries