



**SUPERMINI AND MINI
INTERNAL MACHINING**

INCH AND METRIC TOOLS



2026/2027



EXPLORE HORN

Explore HORN

Outstanding results are always a combination of the optimum cutting process and the perfect tool. To achieve this, HORN combines advanced technology, performance and reliability. From single part to series production, for standard or special applications: Our tools offer you fast, economical, high quality solutions. To assist you when choosing cutting parameters, our tables in the respective catalogue provide proven empirical values. Take advantage of the expertise of our office staff and sales engineers.

Sustainability is a central part of our corporate philosophy. That is why we have always focused on quality assurance, environmental protection, energy efficiency and safety with regard to our products and our production. As an efficient and reliable tool partner, we make sure that you join us in an innovative and strong economic future.

Please visit our eShop, which is available around the clock.



Markus Horn
CEO
Paul Horn GmbH



Matthias Rommel
CEO
Paul Horn GmbH

HORN USA

In 1997, Horn USA was established in Franklin, Tennessee with a clear purpose: deliver world-class precision tooling with true local support for North American manufacturers.

Today, we manufacture in the United States, provide hands-on local engineering, and work side-by-side with customers from concept to finished part. Our team responds quickly, collaborates closely, and delivers solutions built for the demands of American shops.

Backed by the global strength of the HORN Group, we pair advanced R&D and cutting-edge technology with fast, US-based production, including programs like Greenline, where eligible US-made special inserts ship within five working days of design approval.



Chad King
CEO
Horn USA



Mike Csizmar
CSO
Horn USA

HORN TOOL SELECTOR



Scan or click

QUICKLY FIND THE RIGHT TOOLS FOR YOUR JOB

Select your tools with confidence.

Easily filter based on process, material, and parameters.

Spend less time searching and more time machining.

How to find products:

Products are shown in a specific order inside of each chapter.

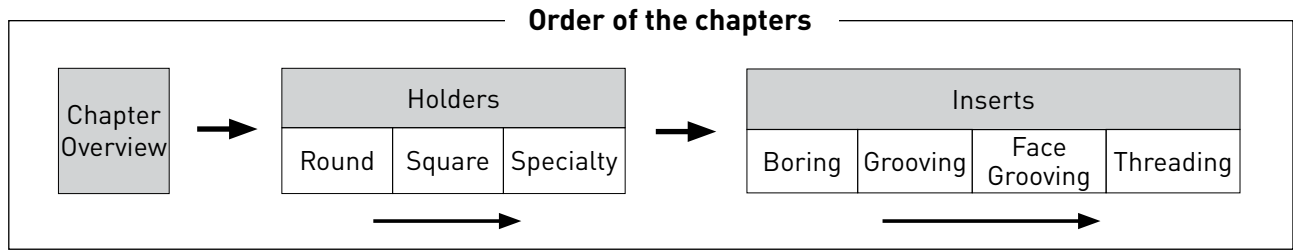

How to choose tools:

- Delivery times
 - ▲ in stock
 - Δ 2 weeks
- Use for material groups
 - recommended
 - suitable
 - not ideal

How to match inserts and holders:

All Horn inserts and toolholders use a connection code system to indicate compatibility between inserts and holders. This code describes the type of insert seat/interface between the insert and holder. (HIS and HWS)
 The same connection code system is used for our modular holders, where the code identifies compatibility between the base holder and cassette. (HMS and HWS)

- HIS** = Horn Insert Side
- HWS** = Horn Interface Holder Side
- HMS** = Horn Interface Machine Side

HIS	↔	HWS
HMS	↔	HWS

Example insert:

Part number	r	f	a	d	l ₂	l ₅	t _{max}	D _{min}	HIS	TH35
R109.1828.1.6	0.2	2.8	5.7	5	10	28	0.4	6	109140	Δ

Correct Match

Example toolholder:

Part number	d	l ₁	h	l ₄	l ₂	d ₂	HWS
B109.0012.01	12	75	10	50	16	20	109140

Supermini:

The Supermini system uses eight sizes of blanks, each with a specific HIS code. The 105 system includes four sizes, 109 and 110 each include two.

The Supermini system uses a symmetrical insert seat, meaning L and R inserts can be paired with L, R, or neutral holders, regardless of hand. Compatibility depends solely on matching the HIS/HWS codes.

Mini:

The Mini system features both symmetric and asymmetric insert seats.

Symmetric Interface Systems - 108, 111, 114, 116

These systems use symmetric insert seats, allowing the same holder to accept both left-hand (L) and right-hand (R) inserts. Holders in these systems have both L and R HWS codes to indicate compatibility with either insert hand.

Asymmetric Interface Systems - 106, 107, 10P, 11P, 18P

These systems use asymmetric insert seats, which require matched hand codes. The L or R HIS/HWS code on the holder must match the L or R code on the insert. Holders in the systems can only be paired with inserts that share the same hand designation.

- A Supermini System 105**
Boring, Grooving, Chamfering, Threading, Face Grooving
Min Bore Ø .008-.236" (0.2-6mm)

- B Supermini System 109**
Boring, Grooving, Chamfering, Threading, Face Grooving
Min Bore Ø .236-.275" (6-7mm)

- C Supermini System 110**
Boring, Grooving, Face Grooving
Min Bore Ø .236-.393" (6-10mm)

- D Mini System 106**
Boring, Grooving, Chamfering
Min Bore Ø .236-.267" (6-6.8mm)

- E Mini System 107**
Boring, Grooving, Chamfering, Threading
Min Bore Ø .275-.354" (7-9mm)

- F Mini System 108**
Boring, Grooving, Chamfering, Threading
Min Bore Ø .307-.354" (7.8-9mm)

- G Mini System 10P**
Boring, Grooving
Min Bore Ø .345-.393" (9-10mm)

- H Mini System 111**
Boring, Grooving, Chamfering, Threading
Min Bore Ø .393-.433" (10-11mm)

- I Mini System 11P**
Boring, Grooving
Min Bore Ø .393-.452" (10-11.5mm)

- J Mini System 114**
Boring, Grooving, Chamfering, Threading, Face Grooving
Min Bore Ø .543-.649" (13.8-16.5mm)

- K Mini System 116**
Boring, Grooving, Chamfering, Threading
Min Bore Ø .551-.629" (14-16mm)

- L Mini System 18P**
Boring, Grooving
Min Bore Ø .708" (18mm)

- M Technical Information**
Coating Overview, Cutting Data, Geometries and Feed Rates,
Machining Examples, Torque Values, Torque Wrenches

	Internal grooving		External grooving
	Internal grooving full radius		External side turning
	Internal boring and grooving chamfer		External copy turning
	Internal boring		Parting off
	Internal back turning		Face turning
	Internal pre-part off and chamfering		Circlip grooves
	Internal grooving with chamfer		Finishing
	Boring and profiling		Micro machining
	Internal chamfering		Hard machining
	Face grooving		Face clamping
	Internal face grooving in front of center		Top clamping
	Offset face grooving		Setup
	Drilling into solid		Internal coolant

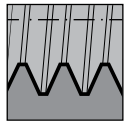

Internal thread

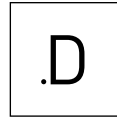

Geometry D



Partial profile thread tool



Geometry FB



Full profile thread tool

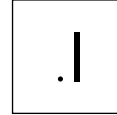

Geometry I

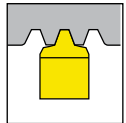

Trapezoidal thread

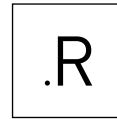

Geometry R



29° thread profile



Geometry GM

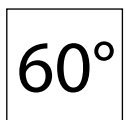

60° thread profile

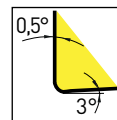

Cutting angle



National pipe thread

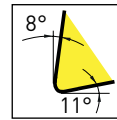

Cutting angle



Unified thread

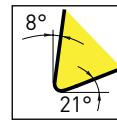

Cutting angle



Whitworth pipe thread
BSW/BSF

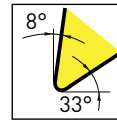

Cutting angle



Steel conduit thread

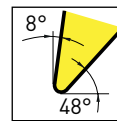

Cutting angle

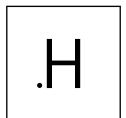

Geometry H

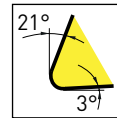

Cutting angle



Geometry HV

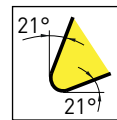

Cutting angle

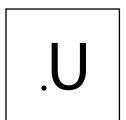

Geometry U

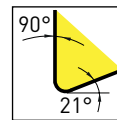

Cutting angle

GREENLINE

Accelerate your success 



Scan or click

SPECIAL TOOLS DISPATCHED IN 5 DAYS OR LESS AFTER DESIGN APPROVAL

New standard process for low-volume specials.

No additional cost to the customer.

Automatically applied to eligible orders.

Scan QR Code for more details.



SUPERMINI 105

Bore Ø		Tool System											
mm	in	105	109	110	106	107	108	10P	111	11P	114	116	18P
≥ 0.2	≥ .0079	•											
≥ 0.5	≥ .0197	•											
≥ 0.7	≥ .0276	•											
≥ 1.0	≥ .0394	•											
≥ 1.5	≥ .0591	•											
≥ 2.0	≥ .0787	•											
≥ 3.0	≥ .1181	•											
≥ 4.0	≥ .1575	•											
≥ 5.0	≥ .1969	•											
≥ 6.0	≥ .2362	•	•	•	•								
≥ 6.8	≥ .2677		•	•	•								
≥ 7.0	≥ .2756		•			•							
≥ 7.8	≥ .3071			•		•	•						
≥ 8.0	≥ .3150			•		•	•						
≥ 9.0	≥ .3543			•		•	•	•					
≥ 10.0	≥ .3937			•				•	•	•			
≥ 10.5	≥ .4134									•			
≥ 11.0	≥ .4331								•	•			
≥ 11.5	≥ .4528									•			
≥ 13.8	≥ .5433										•		
≥ 14.0	≥ .5512										•	•	
≥ 16.0	≥ .6299									•		•	
≥ 16.5	≥ .6496										[•]		
≥ 18.0	≥ .7087												•
Depth of groove		2.5	2.5	4.0	0.8	2.0	1.0	3.0	2.3	3.5	4.0, (6.5)	4.3	8.0
		.0984	.0984	.1575	.0315	.0787	.0394	.1181	.0906	.1378	.1575, (.2559)	.1693	.3150
Width of groove		0.5-2.0	1.0-2.0	1.0-3.0	0.7-1.5	1.0-2.0	0.7-2.0	1.0-3.0	0.7-3.0	1.0-3.0	0.7-3.0	0.7-4.0	2.0-3.0
		.0197- .0787	.0394- .0787	.0394- .1181	.0276- .0591	.0394- .0787	.0276- .0787	.0394- .1181	.0276- .1181	.0394- .1181	.0276- .1181	.0276- .1575	.0787- .1181
Operations													
Grooving		•	•	•	•	•	•	•	•	•	•	•	•
Boring		•	•	•	•	•	•		•		•	•	
Threading		•	•			•	•		•		•	•	
Chamfering		•	•			•	•		•		•	•	
Face Grooving		•	•	•							•		
Boring and Profiling		•					•	•	•	•	•	•	

Round Shank

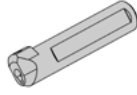

Page 17
Holder BU105
Inch Shank

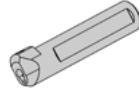

Page 18-20, 28-31
Holder B105

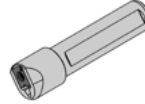

Page 22, 24
Holder BU105.S
Face Clamping, Inch

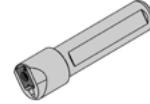

Page 23, 25
Holder B105.S
Face Clamping

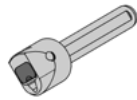

Page 27
Holder B105.A
Top Clamping

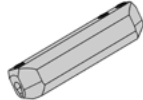

Page 32
Holder BU105
Double Sided, Inch

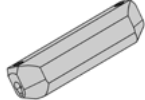

Page 33-36
Holder B105
Double Sided

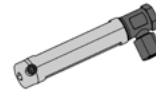

Page 37
Holder IR105

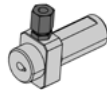

Page 38
Holder IR105



Page 39
Holder B105
Tornos



Page 40
Holder B105

Square Shank

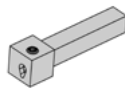

Page 41
Holder HC105

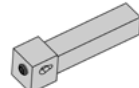

Page 42
Holder HC105

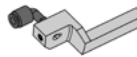

Page 43
Holder HCU105
Inch Shank

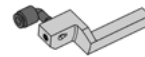

Page 44
Holder HC105

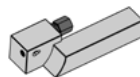

Page 45-46
Holder 962 & 963

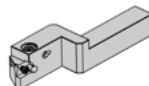

Page 47
Holder AIH

Specialty



Page 48
Holder HC105
Tornos

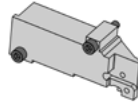

Page 49
Holder L760
Tornos

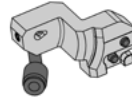

Page 50
Holder KC760

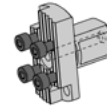

Page 51-52
Holder BGT

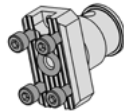

Page 53
Holder BKT
Citizen

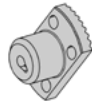

Page 54
Holder BKT



Page 55
Holder BKT
Face Clamping

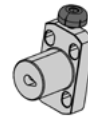

Page 59-63
Holder N
Graf Adjustable

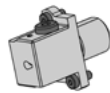

Page 64
Holder B105

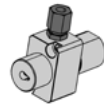

Page 65-66
Holder HF.N
Star

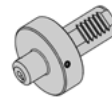

Page 67
Holder VDI

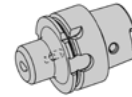

Page 68
Holder HSKT40

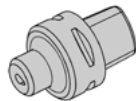

Page 69
Holder B105C
Polygonal

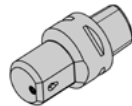

Page 70
Holder B105C
Polygonal

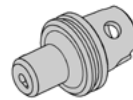

Page 71
Holder B105TS
TS40

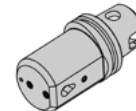

Page 72
Holder B105TS
TS40

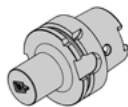

Page 73
Holder B105
HSKT, Face Clamping

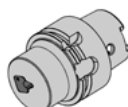

Page 74
Holder B105
HSKT, Top Clamping

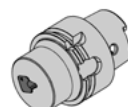

Page 75
Holder B105
HSKT, Top Clamping

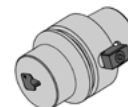

Page 76
B105
HSKT, Top Clamping

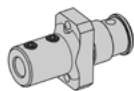

Page 77
Holder 001C
Citizen

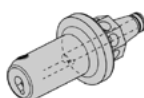

Page 78
Holder WFB.105

INSERTS

Boring



Page 79-80
 .BO Multifunction
 Drilling, Boring, Turning



Page 81-112
 Boring, Profiling,
 Contouring



Page 88
 Boring, Profiling
 .U Chipbreaker



Page 89-96
 Boring
 Super Finishing



Page 105-106
 Boring, Profiling
 .H Chipbreaker



Page 107-110
 Boring, Profiling
 .HV Chipbreaker



Page 113
 Boring, Contouring
 60 HRC and ISO S



Page 114
 Back Boring

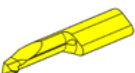

Page 115
 Chamfering and
 Profiling



Page 116
 Chamfering

Grooving



Page 117-128
 Grooving
 Inch



Page 129-137
 Grooving

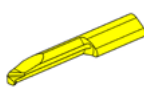

Page 138
 Grooving
 Full Radius, Inch



Page 139-141
 Grooving
 Full Radius







Page 142
 Pre-Part Off

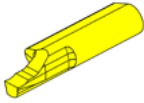
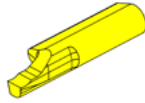
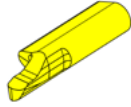
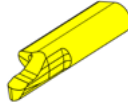
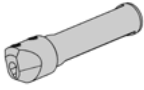
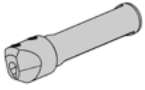
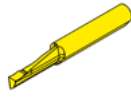

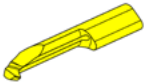
Page 143
 Fine Finishing
 .FB Geometry

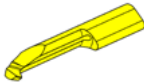
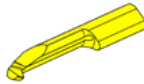
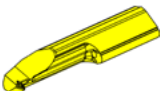
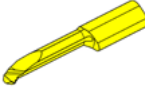
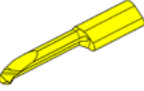
INSERTS, HOLDERS	Face Grooving			
				
	Page 144 Face Grooving Inch	Page 145-148 Face Grooving	Page 149 Face Grooving Full Radius, Inch	Page 150-151 Face Grooving Full Radius
				
	Page 170 Holder BU105 Angled seat, Inch	Page 171 Holder B105 Angled seat	Page 172-173 Face Grooving Angled neck	

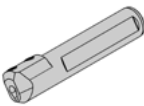
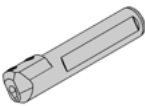
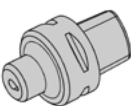
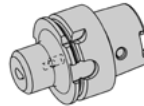
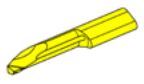
INSERTS	Threading			
				
	Page 152 Threading UN	Page 153-154 Threading, 29° ACME, Partial Profile	Page 155 Threading NPT	Page 156-162 Threading, 60° Partial Profile
				
	Page 161 Threading, 60° .GM Chipbreaker	Page 162 Threading, 60° Full Profile	Page 163-164 Threading BSW/BSF	

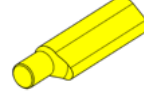
SPECIALTY	Extended Insert Seat			
				
	Page 165 Holder BU105 Extended seat, Inch	Page 166 Holder B105 Extended seat	Page 167 Holder B105C Ext. seat, polygonal	Page 168 Holder HSKT40 Ext. seat, HSKT
				
	Page 169 Boring Extended Shank	Page 174 Setup/Calibration		Page 175 Setup/Calibration

Setup Inserts

Size 3 (HWS = 105123)

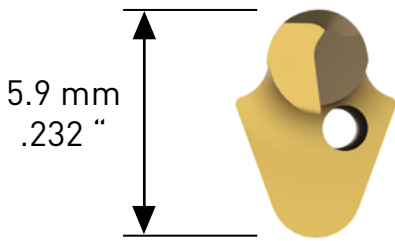

The Supermini 105 system offers three sizes of blanks, each with a specific HIS/HWS code. The Supermini system uses a symmetrical insert seat, meaning L and R inserts can be paired with L, R, or neutral holders, regardless of hand. Compatibility depends solely on matching the HIS/HWS codes.

Holders that feature all three HWS codes are compatible with all three blank sizes.

Example holder:

Part number	HWS
B105.0010.01	105123 • 105124 • 105125

Example inserts:

Part number	HIS
R105.VPM3.4.3	105123

Part number	HIS
R105.1840.3.7	105124

Part number	HIS
RU105.2346.2.4	105125

Compatible with all 3 blank sizes

Size 4 (HWS = 105124)

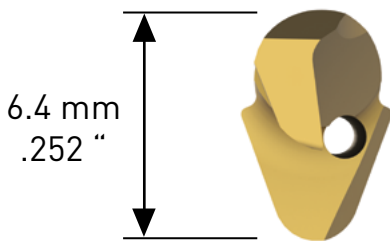

Size 5 (HWS = 105125)

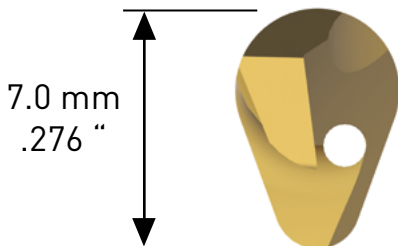

For detailed overviews of the system, helpful tips and tricks, and troubleshooting/setup guides:

Watch our Supermini education series on YouTube!

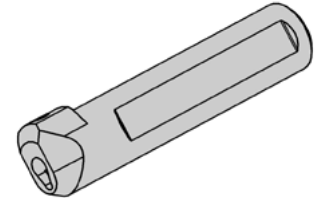
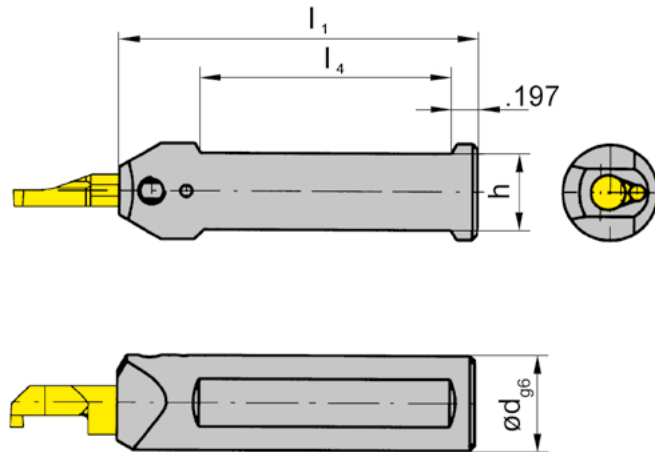
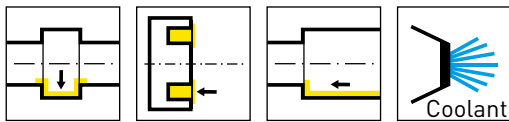

Picture = right hand insert shown

Part number	d	l_1	h	l_4	HWS
BU105.0500.01	.500	2.953	.433	1.969	105123 • 105124 • 105125
BU105.0625.01	.625	2.953	.546	1.969	105123 • 105124 • 105125
BU105.0750.01	.750	3.543	.671	2.756	105123 • 105124 • 105125
BU105.1000.01	1.000	3.543	.921	2.559	105123 • 105124 • 105125

Dimensions in inch



Spare Parts

Note: setup inserts are located at the end of the chapter

Toolholder	Clamping Screw	TORX PLUS® Wrench	Torque Value
BU105...	6.075T15P	T15PQ	5 Nm

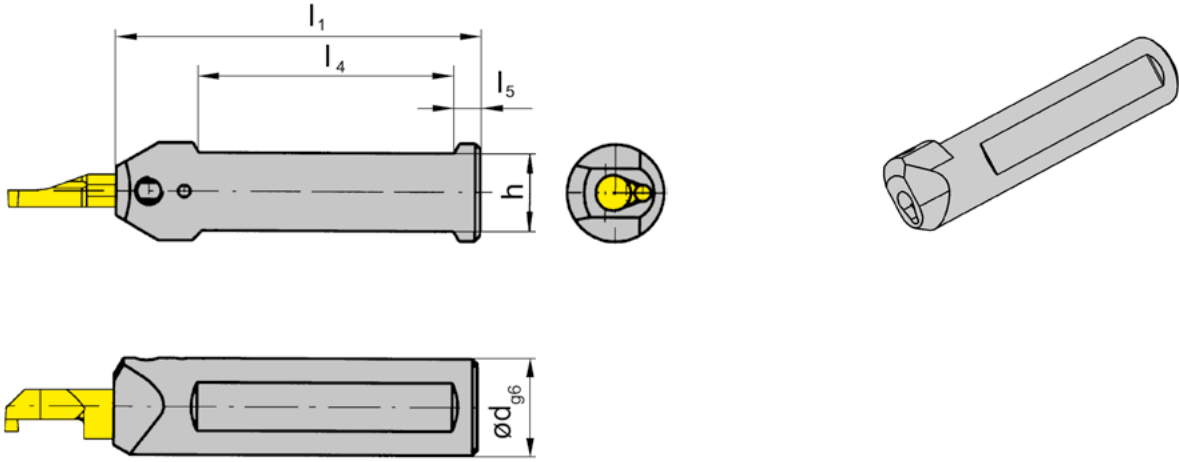
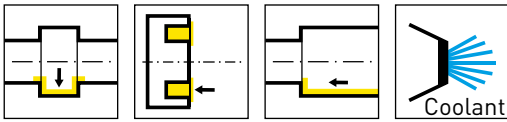

Picture = right hand insert shown

Part number	d	l ₁	h	l ₄	l ₅	HWS
BU105.0750.5.01	.750	3.543	.671	2.756	.197	105123 • 105124 • 105125
BU105.0750.5.3.01	.750	6.004	.671	2.756	.197	105123 • 105124 • 105125
BU105.1000.5.01	1.000	3.543	.921	2.559	.197	105123 • 105124 • 105125
BU105.1000.5.3.01	1.000	6.004	.921	2.756	.197	105123 • 105124 • 105125

M12x1.5 coolant adaptor for Traub machines

Coolant supply hardware is not included

Dimensions in inch



Spare Parts

Note: setup inserts are located at the end of the chapter

Toolholder	Clamping Screw	TORX PLUS® Wrench	Torque Value
BU105...	6.075T15P	T15PQ	5 Nm

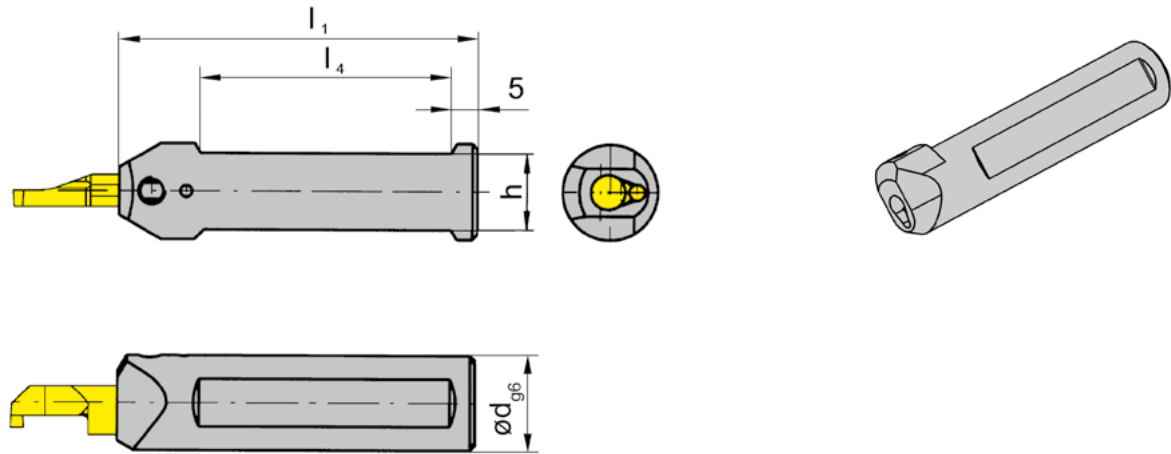
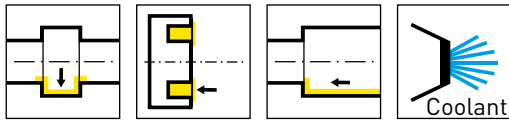

Picture = right hand insert shown

Part number	d	l_1	h	l_4	HWS
B105.0010.01	10	75	9	50	105123 • 105124 • 105125
B105.0012.01	12	75	11	50	105123 • 105124 • 105125
B105.0016.01	16	75	14	50	105123 • 105124 • 105125
B105.0020.01	20	90	18	55	105123 • 105124 • 105125
B105.0022.01	22	90	20	55	105123 • 105124 • 105125
B105.0025.01	25	100	23	55	105123 • 105124 • 105125
B105.0028.01	28	120	26	72	105123 • 105124 • 105125

Dimensions in mm

Spare Parts

Note: setup inserts are located at the end of the chapter

Toolholder	Clamping Screw	TORX PLUS® Wrench	Torque Value
B105...	6.075T15P	T15PQ	5 Nm

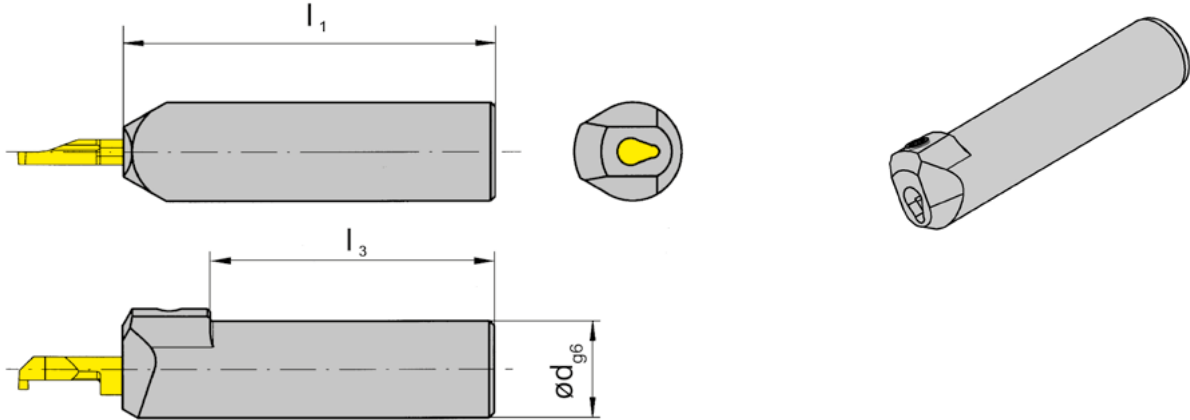
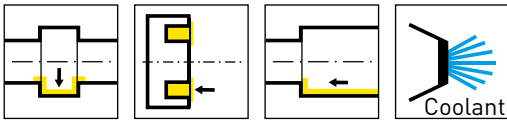

Picture = right hand insert shown

Part number	d	l ₁	l ₃	HWS
B105.0010.01A	10	75	57	105123 • 105124 • 105125
B105.0012.01A	12	75	63	105123 • 105124 • 105125
B105.0016.01A	16	75	63	105123 • 105124 • 105125

Dimensions in mm

Spare Parts

Note: setup inserts are located at the end of the chapter

Toolholder	Clamping Screw	TORX PLUS® Wrench	Torque Value
B105...	6.075T15P	T15PQ	5 Nm

The Supermini Face Clamp system utilizes wedge clamps that secure the Supermini from the front of the holder, allowing users to swap inserts even when space is limited. This is especially useful for Swiss machines where users can't access a normal holder's set screw, requiring the holder to be removed. In addition to the convenience of front access, the face clamp design is incredibly rigid and provides even higher clamping force than the standard set screw design.

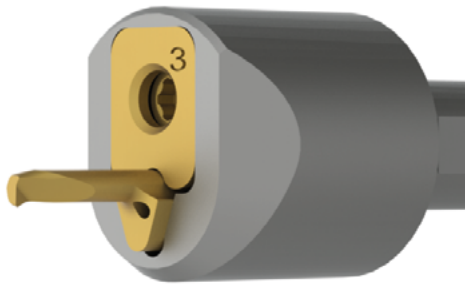

Size 3 (HWS = 105123)

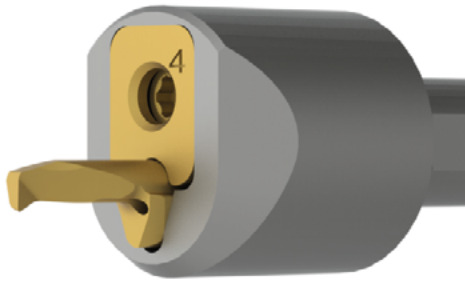
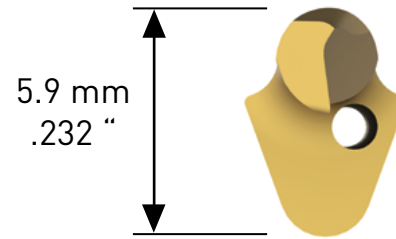

Size 4 (HWS = 105124)

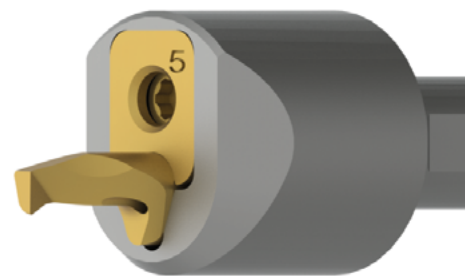
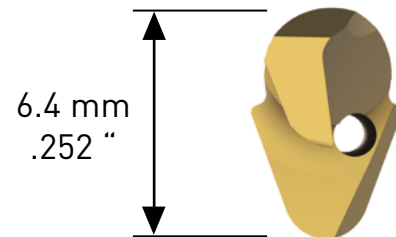

Size 5 (HWS = 105125)

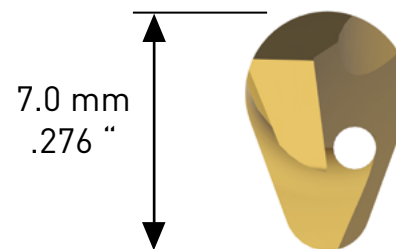

Since the 105 Supermini system comes in 3 sizes of blanks, we offer 3 sizes of face clamps. When ordering a face clamp holder, look at the part number to see which clamp is included. For holders ending in S.03, S.04, or S.05 - the clamp corresponding to that number will be included. If purchasing a holder that ends in S.SET, all 3 clamps will be included.

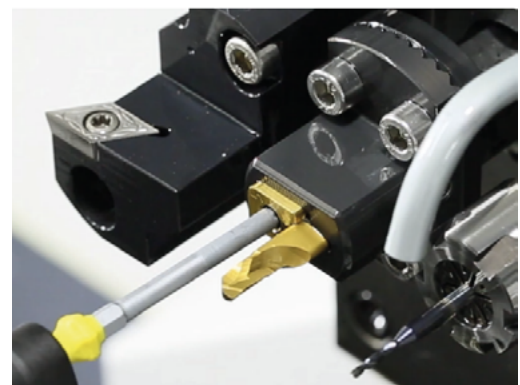

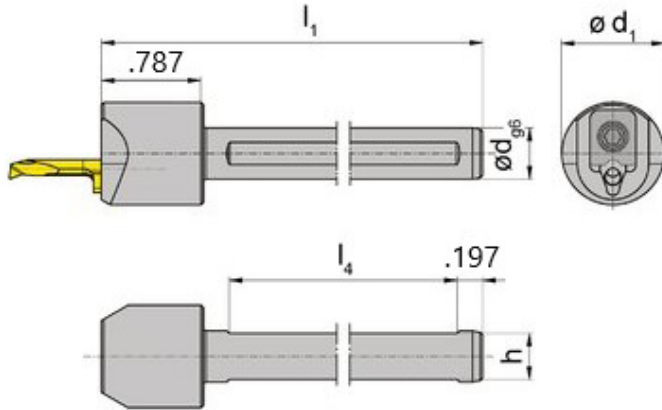
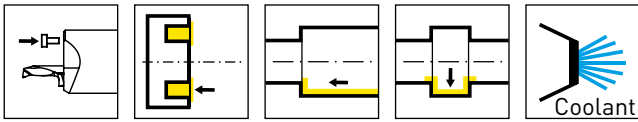

Picture = right hand insert shown

Part number	d	h	l ₁	l ₄	d ₁	HWS
BU105.0500.S.SET	.500	.421	3.150	1.969	.787	105123 • 105124 • 105125
BU105.0625.S.SET	.625	.546	3.150	1.969	.787	105123 • 105124 • 105125
BU105.0750.S.SET	.750	.671	3.543	2.165	.750	105123 • 105124 • 105125
BU105.1000.S.SET	1.000	.921	3.543	2.165	1.000	105123 • 105124 • 105125

Face clamping holders with "S.SET" include all 3 sizes of clamp hardware.

Dimensions in inch



Spare Parts

Note: setup inserts are located at the end of the chapter

Toolholder	Clamping screw	Clamping element	TORX PLUS® Wrench	Torque Value
BU105.S.SET	030.0000.1157	010.0105.03	T15PL	2 Nm
	030.0000.1157	010.0105.04	T15PL	2 Nm
	030.0000.1157	010.0105.05	T15PL	2 Nm

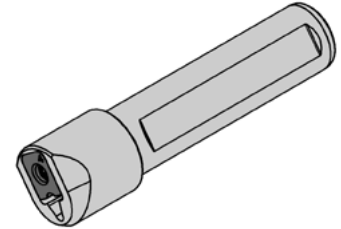
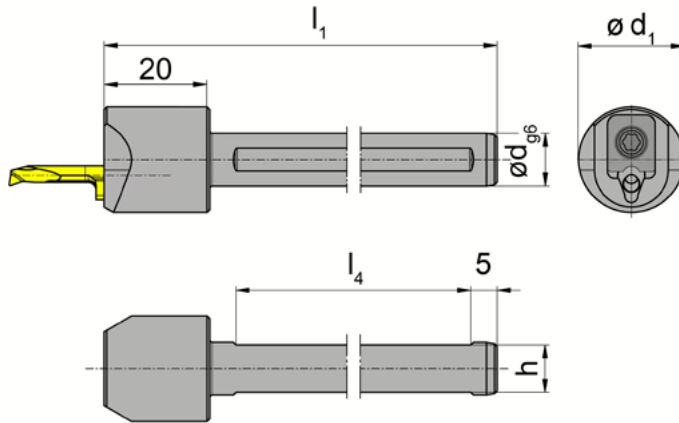
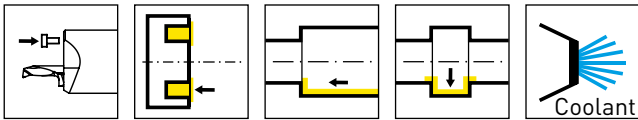

Picture = right hand insert shown

Part number	d	h	l_1	l_4	d_1	HWS
B105.0010.S.SET	10	9	80	50	20	105123 • 105124 • 105125
B105.0012.S.SET	12	11	80	50	20	105123 • 105124 • 105125
B105.0016.S.SET	16	14	80	50	20	105123 • 105124 • 105125
B105.0020.S.SET	20	18	90	55	20	105123 • 105124 • 105125
B105.0022.S.SET	22	20	90	55	22	105123 • 105124 • 105125
B105.0025.S.SET	25	23	100	55	25	105123 • 105124 • 105125
B105.0028.S.SET	28	26	120	55	28	105123 • 105124 • 105125

Face clamping holders with "S.SET" include all 3 sizes of clamp hardware.

Dimensions in mm

Spare Parts

Note: setup inserts are located at the end of the chapter

Toolholder	Clamping screw	Clamping element	TORX PLUS® Wrench	Torque Value
B105.S.SET	030.0000.1157	010.0105.03	T15PL	2 Nm
	030.0000.1157	010.0105.04	T15PL	2 Nm
	030.0000.1157	010.0105.05	T15PL	2 Nm

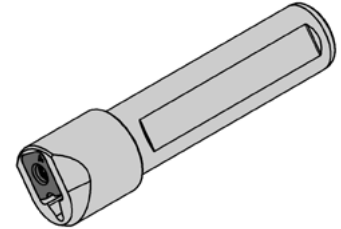
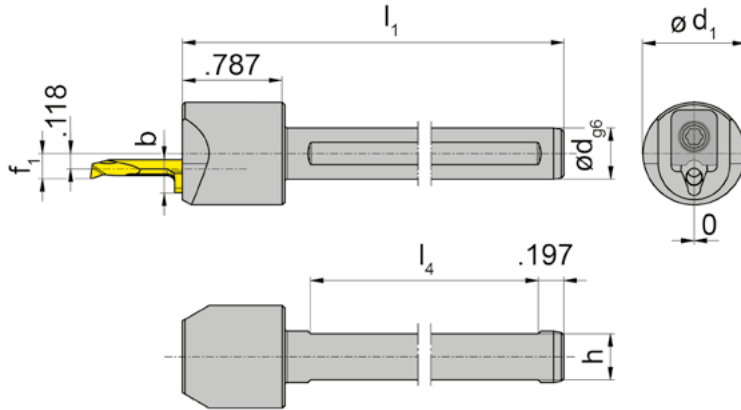
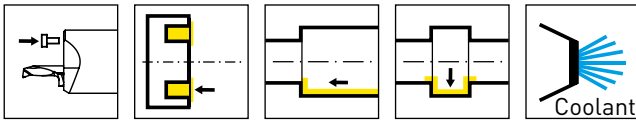

Picture = right hand insert shown

Part number	d	l ₁	h	l ₄	f ₁	d ₁	b	HWS
BU105.0500.S.03	.500	3.150	.421	1.969	.169	.787	.232	105123
BU105.0625.S.03	.625	3.150	.546	1.969	.169	.787	.232	105123
BU105.0750.S.03	.750	3.543	.671	2.165	.169	.750	.232	105123
BU105.1000.S.03	1.000	3.543	.921	2.165	.169	1.000	.232	105123
BU105.0500.S.04	.500	3.150	.421	1.969	.193	.787	.252	105124
BU105.0625.S.04	.625	3.150	.546	1.969	.193	.787	.252	105124
BU105.0750.S.04	.750	3.543	.671	2.165	.193	.750	.252	105124
BU105.1000.S.04	1.000	3.543	.921	2.165	.193	1.000	.252	105124
BU105.0500.S.05	.500	3.150	.421	1.969	.248	.787	.276	105125
BU105.0625.S.05	.625	3.150	.546	1.969	.248	.787	.276	105125
BU105.0750.S.05	.750	3.543	.671	2.165	.248	.750	.276	105125
BU105.1000.S.05	1.000	3.543	.921	2.165	.248	1.000	.276	105125

Face clamping holders with ".S.0_" only include the clamp size associated with the holder's HWS code. Other clamp sizes must be purchased separately.

Dimensions in inch



Spare Parts

Note: setup inserts are located at the end of the chapter

Toolholder	Clamping screw	Clamping element	TORX PLUS® Wrench	Torque Value
BU105...S.03	030.0000.1157	010.0105.03	T15PL	2 Nm
BU105...S.04	030.0000.1157	010.0105.04	T15PL	2 Nm
BU105...S.05	030.0000.1157	010.0105.05	T15PL	2 Nm

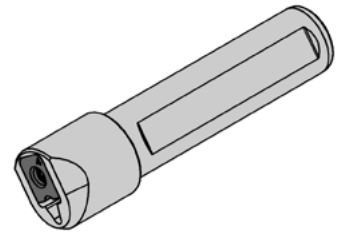
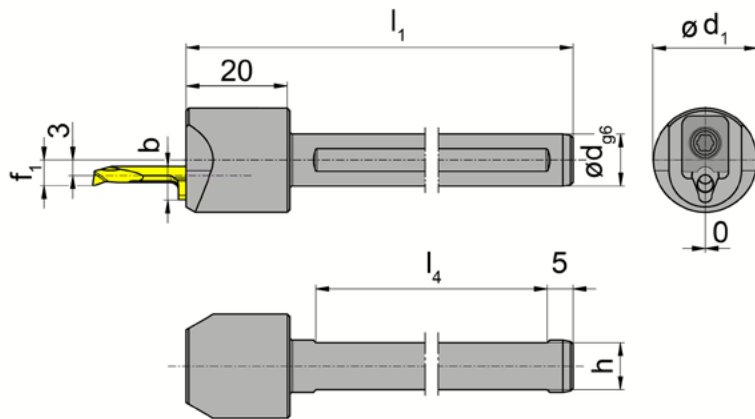
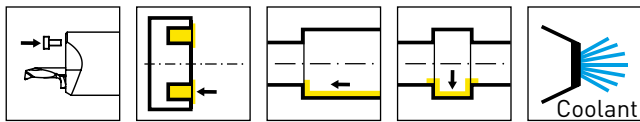

Picture = right hand insert shown

Part number	d	l_1	h	l_4	f_1	d_1	b	HWS
B105.0010.S.03	10	80	9	50	4.3	20	5.9	105123
B105.0012.S.03	12	80	11	50	4.3	20	5.9	105123
B105.0016.S.03	16	80	14	50	4.3	20	5.9	105123
B105.0020.S.03	20	90	18	55	4.3	20	5.9	105123
B105.0022.S.03	22	90	20	55	4.3	22	5.9	105123
B105.0025.S.03	25	100	23	55	4.3	25	5.9	105123
B105.0028.S.03	28	120	26	55	4.3	28	5.9	105123
B105.0010.S.04	10	80	9	50	4.9	20	6.4	105124
B105.0012.S.04	12	80	11	50	4.9	20	6.4	105124
B105.0016.S.04	16	80	14	50	4.9	20	6.4	105124
B105.0020.S.04	20	90	18	55	4.9	20	6.4	105124
B105.0022.S.04	22	90	20	55	4.9	22	6.4	105124
B105.0025.S.04	25	100	23	55	4.9	25	6.4	105124
B105.0028.S.04	28	120	26	55	4.9	28	6.4	105124
B105.0010.S.05	10	80	9	50	6.3	20	7	105125
B105.0012.S.05	12	80	11	50	6.3	20	7	105125
B105.0016.S.05	16	80	14	50	6.3	20	7	105125
B105.0020.S.05	20	90	18	55	6.3	20	7	105125
B105.0022.S.05	22	90	20	55	6.3	22	7	105125
B105.0025.S.05	25	100	23	55	6.3	25	7	105125
B105.0028.S.05	28	120	26	55	6.3	28	7	105125

Face clamping holders with ".S.0_" only include the clamp size associated with the holder's HWS code. Other clamp sizes must be purchased separately.

Dimensions in mm

Spare Parts

Note: setup inserts are located at the end of the chapter

Toolholder	Clamping screw	Clamping element	TORX PLUS® Wrench	Torque Value
B105...S0.03	030.0000.1157	010.0105.03	T15PL	2 Nm
B105...S0.04	030.0000.1157	010.0105.04	T15PL	2 Nm
B105...S0.05	030.0000.1157	010.0105.05	T15PL	2 Nm

The Supermini Top Clamp system utilizes wedge clamps that secure the Supermini with a vertical screw, allowing users to swap inserts even when space is limited. The top clamp design is incredibly rigid and provides even higher clamping force than the standard set screw design.



Size 3 (HWS = 105123)

5.9 mm
.232 "

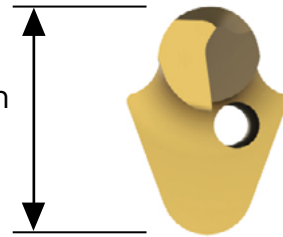

Size 4 (HWS = 105124)

6.4 mm
.252 "

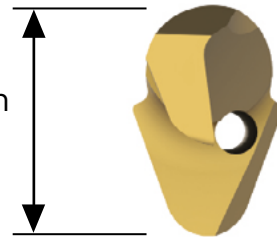

Size 5 (HWS = 105125)

7.0 mm
.276 "

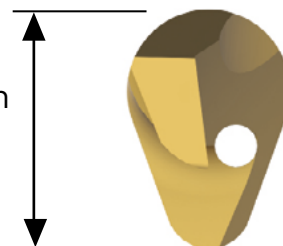

Since the 105 Supermini system comes in 3 sizes of blanks, we offer 3 sizes of top clamps. When ordering a top clamp holder, look at the part number to see which clamp is included. For holders ending in A.03, A.04, or A.05 - the clamp corresponding to that number will be included.

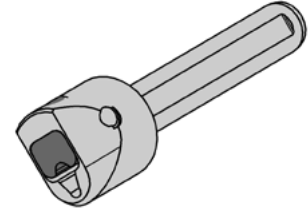
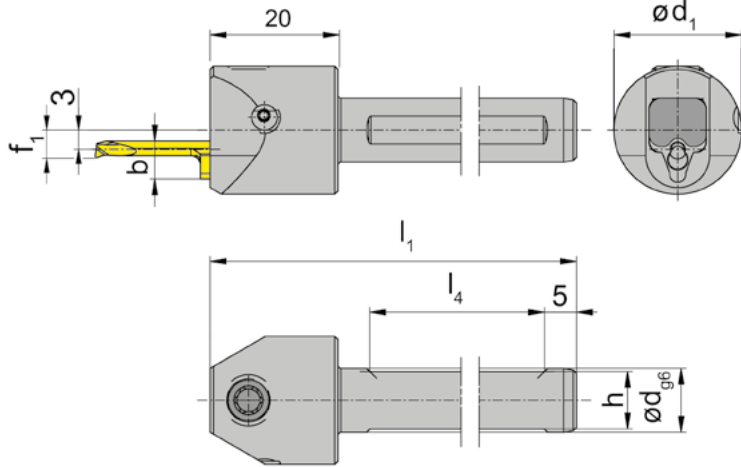
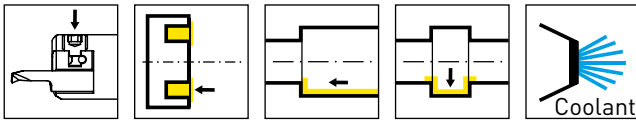

Picture = right hand insert shown

Part number	d	l ₁	h	l ₄	f ₁	d ₁	b	HWS
B105.0010.A.03	10	80	9	50	4.3	20	5.9	105123
B105.0012.A.03	12	80	11	50	4.3	20	5.9	105123
B105.0016.A.03	16	80	14	50	4.3	20	5.9	105123
B105.0020.A.03	20	90	18	55	4.3	20	5.9	105123
B105.0025.A.03	25	100	23	55	4.3	25	5.9	105123
B105.0010.A.04	10	80	9	50	4.9	20	6.4	105124
B105.0012.A.04	12	80	11	50	4.9	20	6.4	105124
B105.0016.A.04	16	80	14	50	4.9	20	6.4	105124
B105.0020.A.04	20	90	18	55	4.9	20	6.4	105124
B105.0025.A.04	25	100	23	55	4.9	25	6.4	105124
B105.0010.A.05	10	80	9	50	6.3	20	7	105125
B105.0012.A.05	12	80	11	50	6.3	20	7	105125
B105.0016.A.05	16	80	14	50	6.3	20	7	105125
B105.0020.A.05	20	90	18	55	6.3	20	7	105125
B105.0025.A.05	25	100	23	55	6.3	25	7	105125

The ".A" style holder features a top-clamping design with a face wedge clamping element. Top clamping holders with ".A.0_" only include the clamp size associated with the holder's HWS code. Other clamp sizes must be purchased separately.

Dimensions in mm

Spare Parts

Note: setup inserts are located at the end of the chapter

Toolholder	Clamping screw	Clamping element	TORX PLUS® Wrench	Torque Value
B105...A0.03	030.00M8.1188	010.0003.0668	T25PQ	4 Nm
B105...A0.04	030.00M8.1188	010.0004.0667	T25PQ	4 Nm
B105...A0.05	030.00M8.1188	010.0005.0663	T25PQ	4 Nm

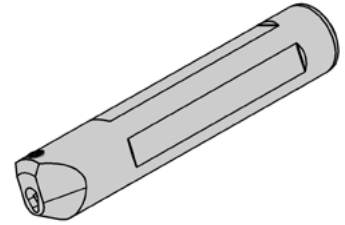
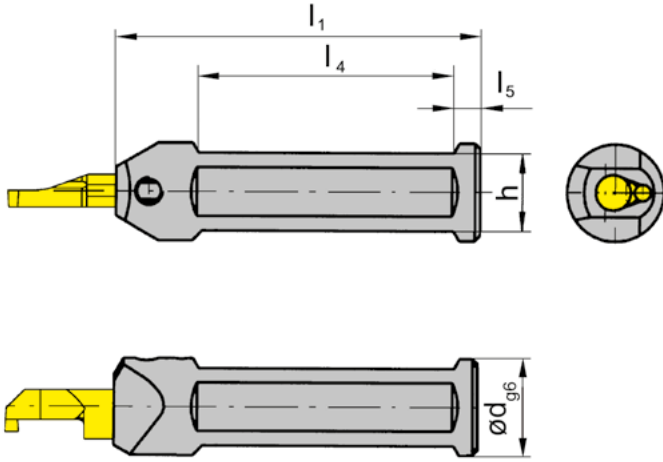
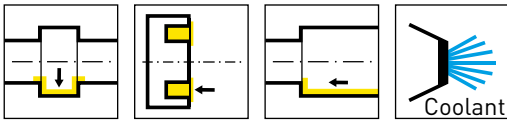

Picture = right hand insert shown

Part number	d	l ₁	h	l ₄	l ₅	HWS
B105.0022.1.2.01	22	120	20	72	5	105123 • 105124 • 105125

Dimensions in mm

Spare Parts

Note: setup inserts are located at the end of the chapter

Toolholder	Clamping Screw	TORX PLUS® Wrench	Torque Value
B105.0022.1.2.01	6.075T15P	T15PQ	5 Nm

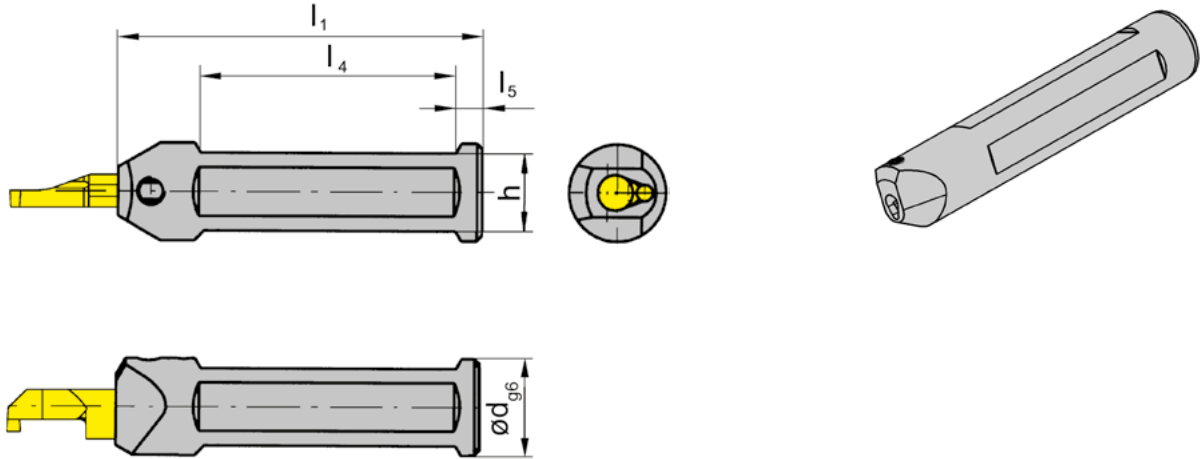
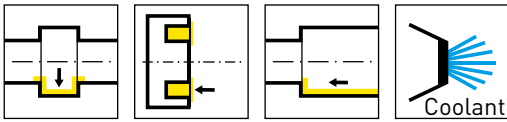

Picture = right hand insert shown

Part number	d	l ₁	h	l ₄	l ₅	HWS
B105.0022.1.4.01	22	115	20	80	5	105123 • 105124 • 105125
B105.0025.NPT.01	25	150	23	100	5	105123 • 105124 • 105125

These holders use 1/8-27 NPT thread coolant connections

Dimensions in mm

Spare Parts

Note: setup inserts are located at the end of the chapter

Toolholder	Clamping Screw	TORX PLUS® Wrench	Torque Value
B105.0022.1.4.01	6.075T15P	T15PQ	5 Nm
B105.0025.NPT.01	6.075T15P	T15PQ	5 Nm

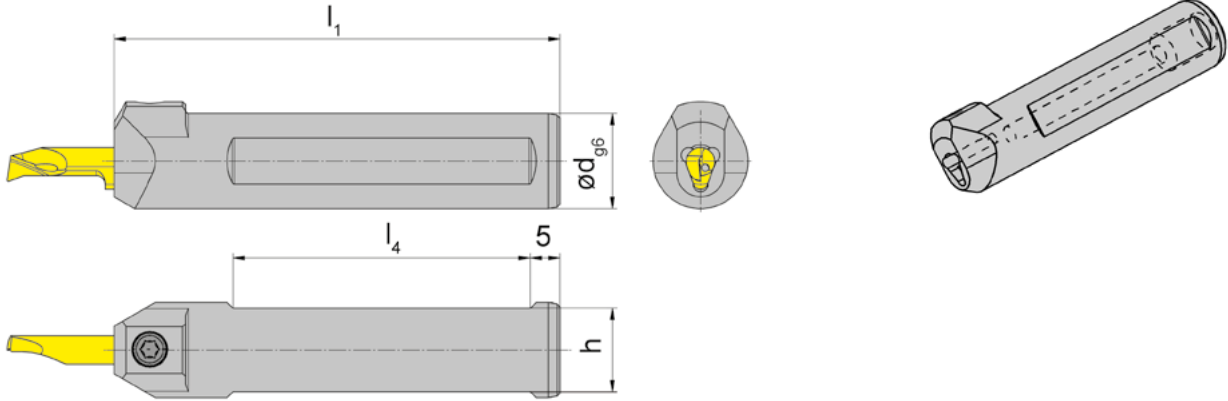
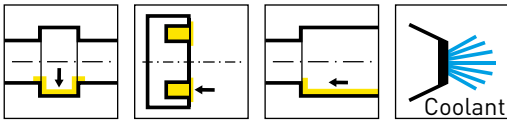

Picture = right hand insert shown

Part number	d	l ₁	h	l ₄	HWS
B105.0012.K.01	12	75	11	50	105123 • 105124 • 105125
B105.0016.K.01	16	75	14	50	105123 • 105124 • 105125
B105.0020.K.01	20	90	18	50	105123 • 105124 • 105125
B105.0022.K.01	22	90	20	55	105123 • 105124 • 105125
B105.0025.K.01	25	100	23	55	105123 • 105124 • 105125
B105.0016.M8.K.01	16	75	14	50	105123 • 105124 • 105125
B105.0020.M8.K.01	20	90	18	55	105123 • 105124 • 105125

These holders use M8x1 thread coolant connections

Dimensions in mm

This holder features additional coolant holes

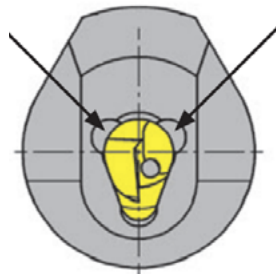

Spare Parts

Note: setup inserts are located at the end of the chapter

Toolholder	Clamping Screw	TORX PLUS® Wrench	Torque Value
B105...	6.075T15P	T15PQ	5 Nm

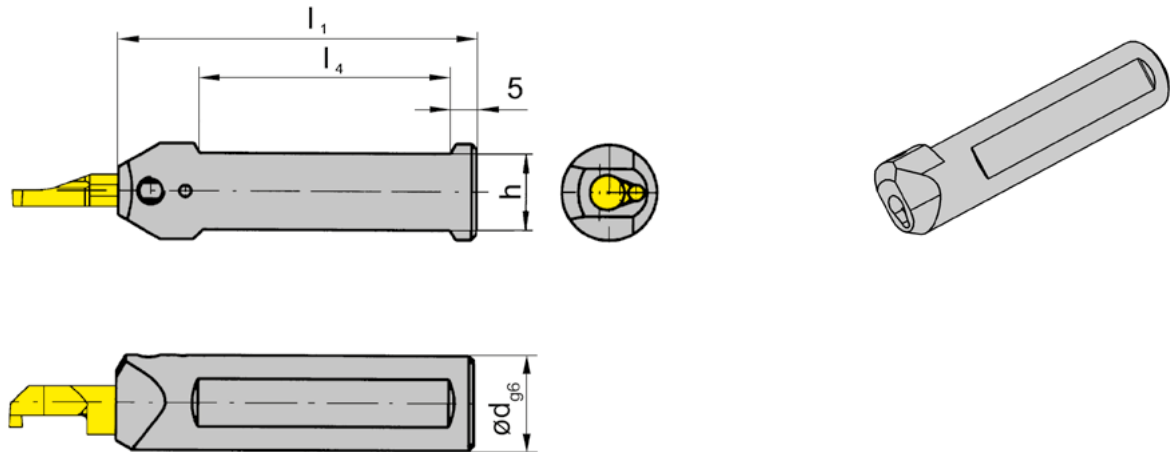
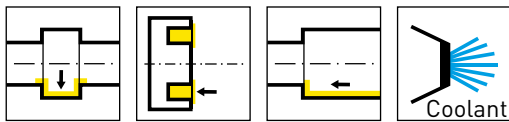

Picture = right hand insert shown

Part number	d	l_1	h	l_4	HWS
B105.0012.M8.01	12	75	11	50	105123 • 105124 • 105125
B105.0016.M8.01	16	75	14	50	105123 • 105124 • 105125
B105.0020.M8.01	20	90	18	55	105123 • 105124 • 105125
B105.0025.M8.01	25	100	23	55	105123 • 105124 • 105125

These holders use M8x1 thread coolant connections

Dimensions in mm

Spare Parts

Note: setup inserts are located at the end of the chapter

Toolholder	Clamping Screw	TORX PLUS® Wrench	Torque Value
B105...	6.075T15P	T15PQ	5 Nm

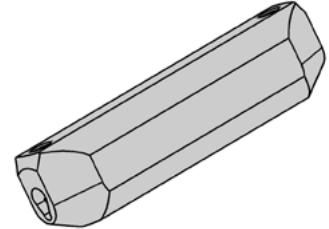
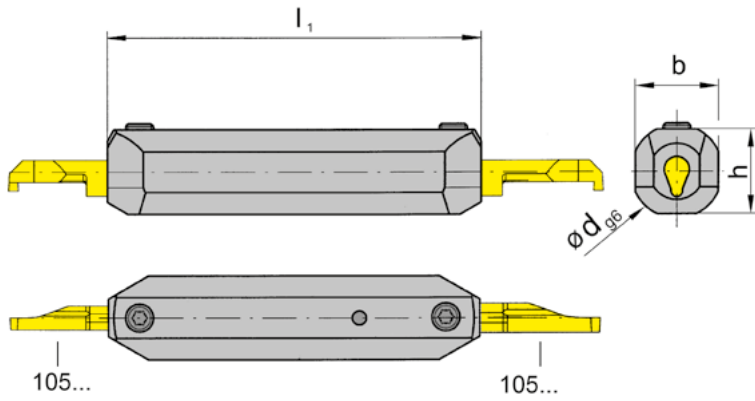
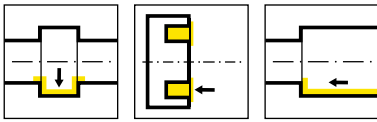

Picture = right and left hand insert shown

Part number	d	l ₁	h	HWS
BU105.0750.2.2.01	.750	4.724	.671	105123 • 105124 • 105125

Dimensions in inch



Spare Parts

Note: setup inserts are located at the end of the chapter

Toolholder	Clamping Screw	TORX PLUS® Wrench	Torque Value
BU105.0750.2.2.01	6.075T15P	T15PQ	5 Nm

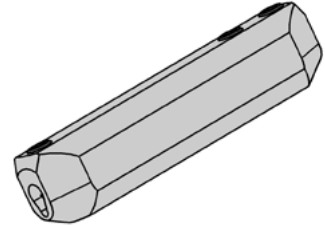
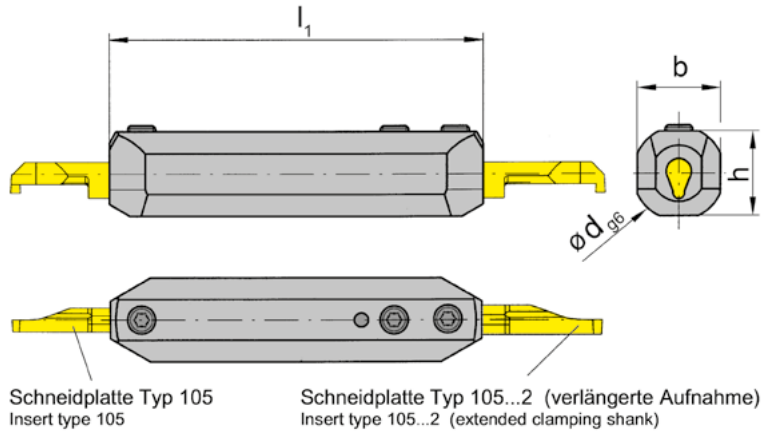
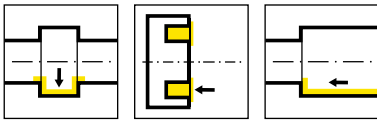

Picture = right hand insert shown

Part number	d	l_1	h	b	HWS
B105.0020.1.03	20	80	18	18	105123 • 105124 • 105125 • 105225

Dimensions in mm

Spare Parts

Note: setup inserts are located at the end of the chapter

Toolholder	Clamping Screw	TORX PLUS® Wrench	Torque Value
B105.0020.1.03	6.075T15P	T15PQ	5 Nm

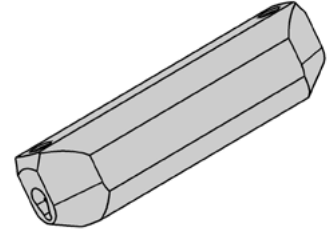
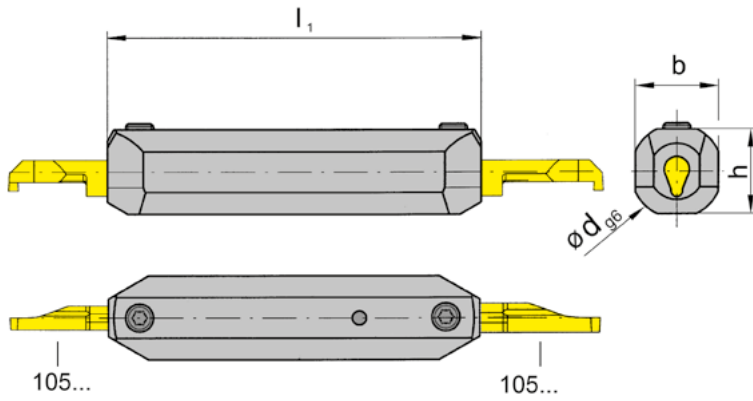
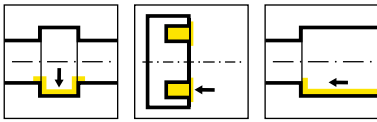

Picture = right hand insert shown

Part number	d	l ₁	h	b	HWS
B105.0022.2.1.01	22	80	20	20	105123 • 105124 • 105125
B105.0022.2.2.01	22	120	20	20	105123 • 105124 • 105125

Dimensions in mm

Spare Parts

Note: setup inserts are located at the end of the chapter

Toolholder	Clamping Screw	TORX PLUS® Wrench	Torque Value
B105...	6.075T15P	T15PQ	5 Nm

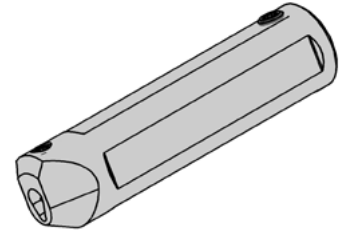
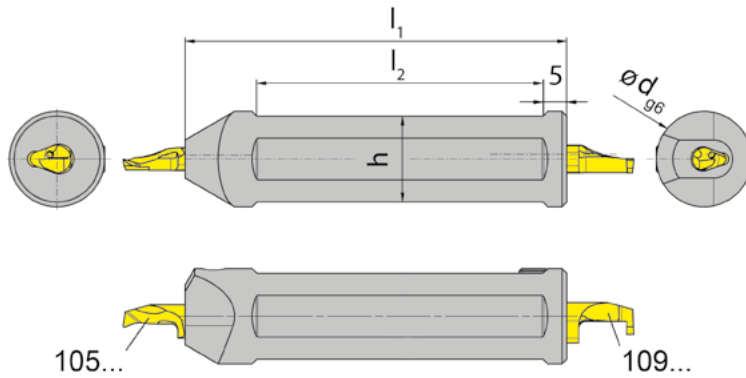
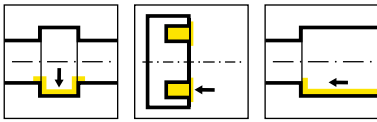

Part number	d	l ₁	h	l ₂	HWS
B105.0020.1.09	20	80	18	60	105123 • 105124 • 105125 • 109140

Dimensions in mm

Spare Parts

Note: setup inserts are located at the end of the chapter

Toolholder	Clamping Screw	TORX PLUS® Wrench	Torque Value
B105.0020.1.09	6.075T15P	T15PQ	5 Nm

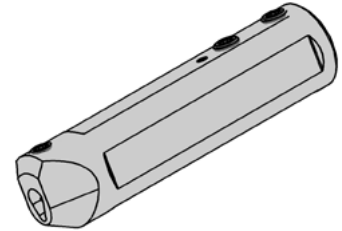
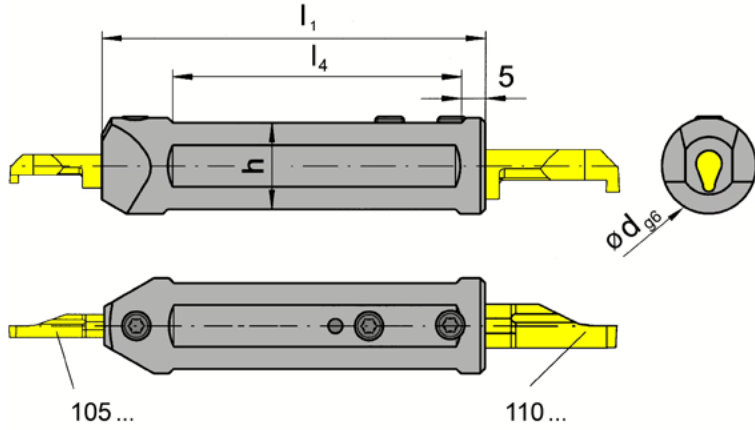
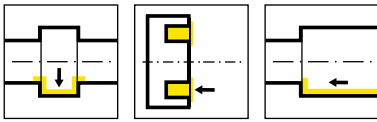

Part number	d	l ₁	h	l ₄	HWS
B105.0020.1.10	20	80	18	60	105123 • 105124 • 105125 • 110260

Dimensions in mm

Spare Parts

Note: setup inserts are located at the end of the chapter

Toolholder	Clamping Screw	TORX PLUS® Wrench	Torque Value
B105.0020.1.10	6.075T15P	T15PQ	5 Nm

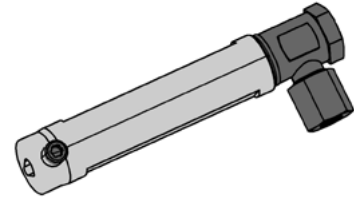
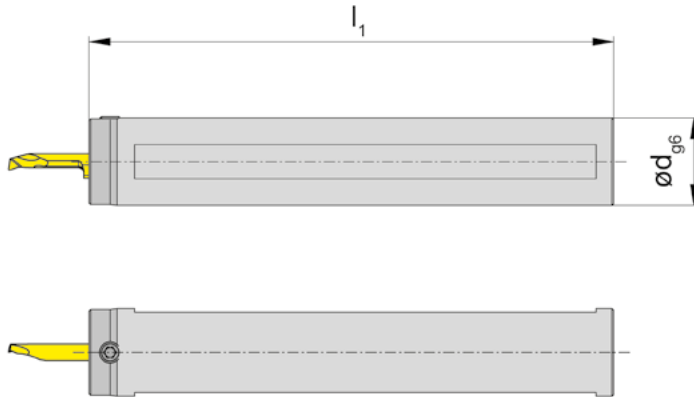
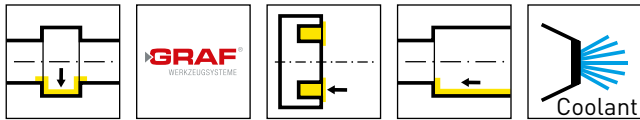

Picture = right hand insert shown

Part number	d	l ₁	Machine type	HWS
IR.105.34.100.IK	3/4"	100	Citizen	105123 • 105124 • 105125
IR.105.34.40.IK	3/4"	40	Citizen	105123 • 105124 • 105125
IR.105.34.50.IK	3/4"	50	Citizen	105123 • 105124 • 105125
IR.105.34.70.IK	3/4"	70	Citizen	105123 • 105124 • 105125
IR.105.10.100.IK	1"	100	Citizen	105123 • 105124 • 105125
IR.105.10.60.IK	1"	60	Citizen	105123 • 105124 • 105125
IR.105.20.30.IK	20	30	Citizen	105123 • 105124 • 105125
IR.105.20.50.IK	20	50	Citizen	105123 • 105124 • 105125
IR.105.16.100.IK	16	100	Star	105123 • 105124 • 105125
IR.105.16.30.IK	16	30	Star	105123 • 105124 • 105125
IR.105.16.50.IK	16	50	Star	105123 • 105124 • 105125
IR.105.16.70.IK	16	70	Star	105123 • 105124 • 105125
IR.105.20.100.IK	20	100	Star	105123 • 105124 • 105125
IR.105.22.100.IK	22	100	Star	105123 • 105124 • 105125
IR.105.22.120.3.IK	22	120	Star	105123 • 105124 • 105125
IR.105.22.120.IK	22	120	Star	105123 • 105124 • 105125
IR.105.22.150.IK	22	150	Star	105123 • 105124 • 105125
IR.105.22.38.IK	22	38	Star	105123 • 105124 • 105125
IR.105.22.50.IK	22	50	Star	105123 • 105124 • 105125
IR.105.22.70.IK	22	70	Star	105123 • 105124 • 105125
IR.105.20.170.IK	20	170	Tornos	105123 • 105124 • 105125
IR.105.20.185.IK	20	185	Tornos	105123 • 105124 • 105125
IR.105.25.100.IK	25	100	Tornos	105123 • 105124 • 105125
IR.105.25.150.IK	25	150	Tornos	105123 • 105124 • 105125
IR.105.28.80.IK	28	80	Tornos	105123 • 105124 • 105125

The coolant connection is a male 1/8" G thread.

Dimensions in mm unless stated otherwise

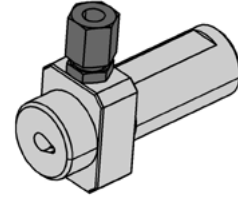
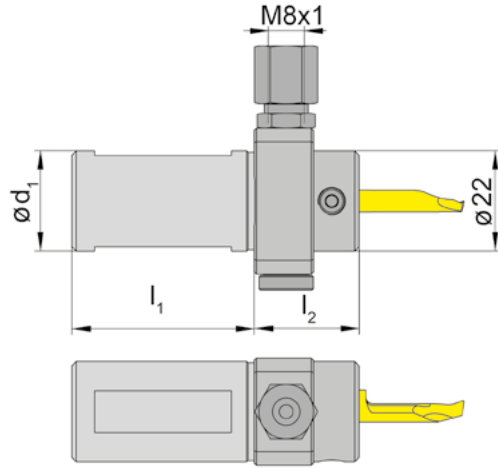
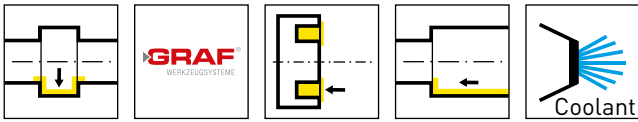

Picture = right hand insert shown

Part number	d_1	l_1	l_2	HWS
IR.105.1640.IKV	16	40	25	105123 • 105124 • 105125
IR.105.3440.IKV	3/4"	40	25	105123 • 105124 • 105125
IR.105.2040.IKV	20	40	25	105123 • 105124 • 105125
IR.105.2240.IKV	22	40	25	105123 • 105124 • 105125
IR.105.2560.IKV	25	60	25	105123 • 105124 • 105125
IR.105.1060.IKV	1"	60	25	105123 • 105124 • 105125

Dimensions in mm unless stated otherwise

Spare Parts

Note: setup inserts are located at the end of the chapter

Cartridge Graf	Clamping Screw	Coolant supply	TORX PLUS® Wrench	Torque Value
IR...	6.075T15P	004.00.19	T15PQ	5 Nm

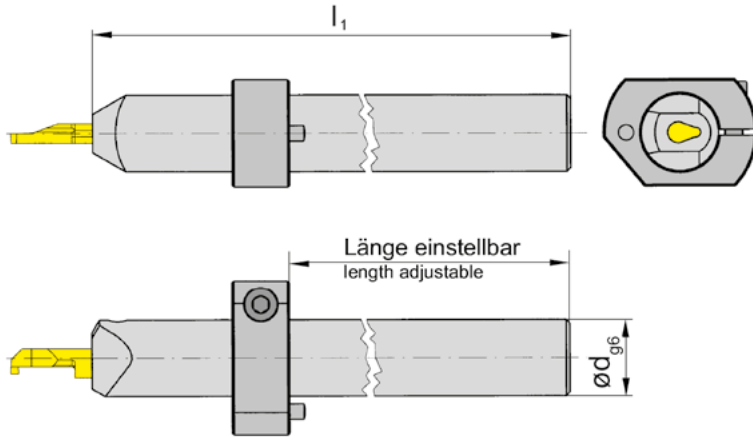
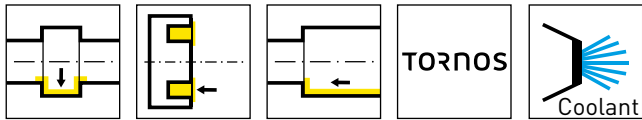

Picture = right hand insert shown

Part number	d	l_1	HWS
B105.0020.2.01	20	150	105123 • 105124 • 105125
B105.0025.2.01	25	150	105123 • 105124 • 105125

Adjustment ring is not included with the toolholder - separate order required

Dimensions in mm

Adjustment ring	d	Machine Type
020.0020.1665	20	Tornos
020.0025.2234	25	Tornos

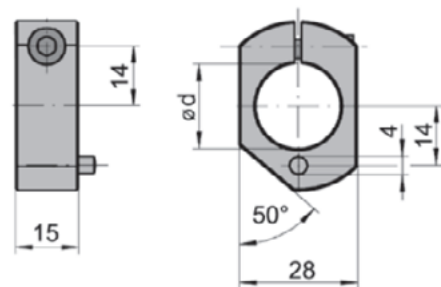

Spare Parts

Note: setup inserts are located at the end of the chapter

Toolholder	Clamping Screw	TORX PLUS® Wrench	Torque Value
B105...	6.075T15P	T15PQ	5 Nm

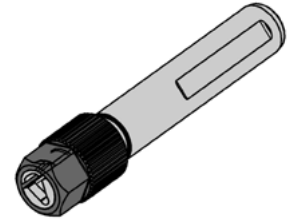
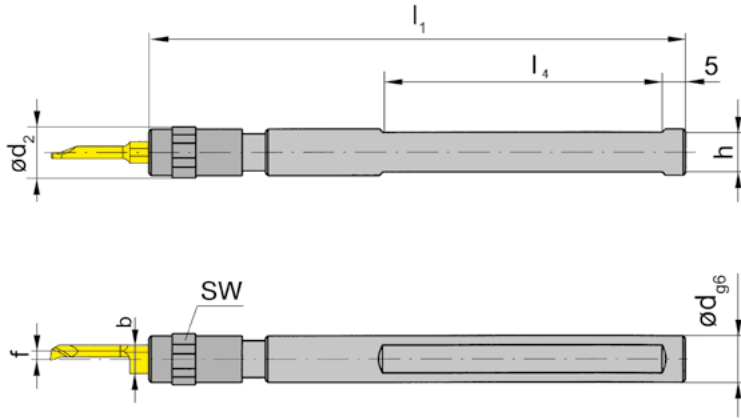
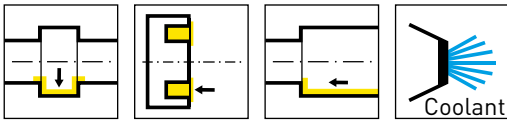

Picture = right hand insert shown

Part number	d	l ₁	h	l ₄	f	d ₂	SW	b	HWS
B105.0010.9.01	10	100	9	50	1.6	11	10	5.9	105123
B105.0012.11.01	12	100	11	50	1.2	16	13	7	105125
B105.0016.11.01	16	100	15	50	1.2	16	13	7	105125

b = Height of insert

Dimensions in mm

Spare Parts

Note: setup inserts are located at the end of the chapter

Toolholder	Clamping nut
B105.0010.9.01	020.0010.1719
B105.0012/0016	020.0016.1999

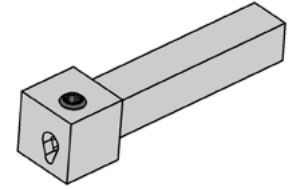
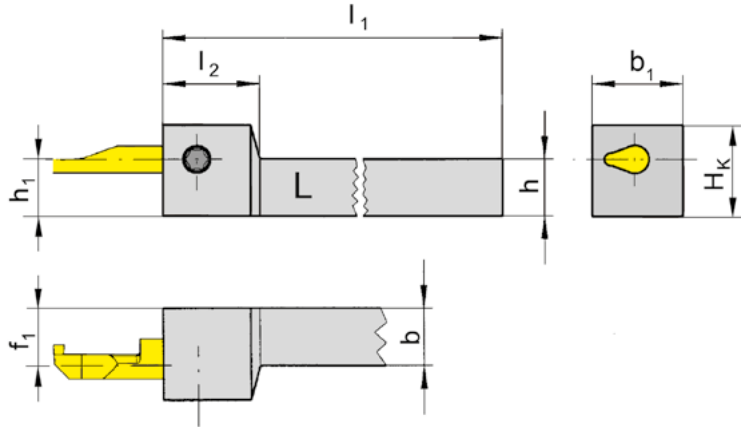
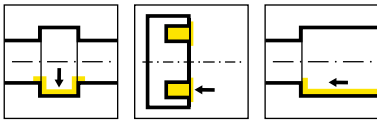

L = left hand version shown

R = right hand version

Part number	h	b	l_1	h_1	b_1	f_1	H_k	l_2	HWS
RH105.0808.01	8	8	90	8	16	7.5	14	17	105123 • 105124 • 105125
RH105.1010.01	10	10	90	10	16	7.5	16	17	105123 • 105124 • 105125
RH105.1212.01	12	12	90	12	16	7.5	18	17	105123 • 105124 • 105125
RH105.1616.01	16	16	110	16	16	7.5	22	17	105123 • 105124 • 105125
LH105.0808.01	8	8	90	8	16	7.5	14	17	105123 • 105124 • 105125
LH105.1010.01	10	10	90	10	16	7.5	16	17	105123 • 105124 • 105125
LH105.1212.01	12	12	90	12	16	7.5	18	17	105123 • 105124 • 105125
LH105.1616.01	16	16	110	16	16	7.5	22	17	105123 • 105124 • 105125

Dimensions in mm

Spare Parts

Note: setup inserts are located at the end of the chapter

Toolholder	Clamping Screw	TORX PLUS® Wrench	Torque Value
R/LH105...	6.075T15P	T15PQ	5 Nm

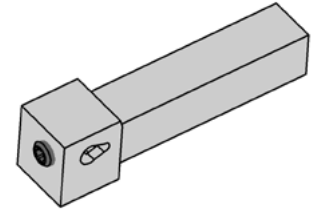
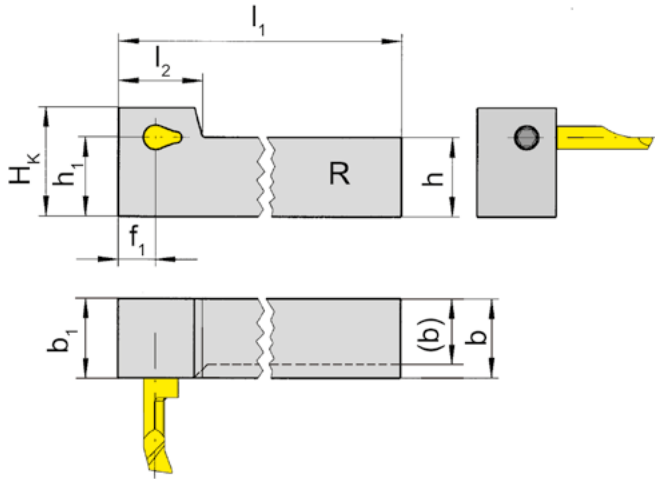
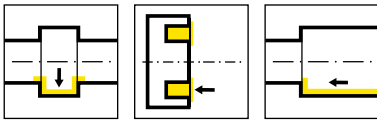

R = right hand version shown

L = left hand version

Part number	h	b	l ₁	l ₂	h ₁	b ₁	f ₁	H _k	HWS
RHC105.1212.01	12	12	90	17	12	16	7.5	18	105123 • 105124 • 105125
RHC105.1616.01	16	16	130	17	16	16	7.5	22	105123 • 105124 • 105125
LHC105.1212.01	12	12	90	17	12	16	7.5	18	105123 • 105124 • 105125
LHC105.1616.01	16	16	130	17	16	16	7.5	22	105123 • 105124 • 105125

Dimensions in mm

Spare Parts

Note: setup inserts are located at the end of the chapter

Toolholder	Clamping Screw	TORX PLUS® Wrench	Torque Value
R/LHC105...	6.075T15P	T15PQ	5 Nm

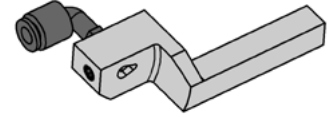
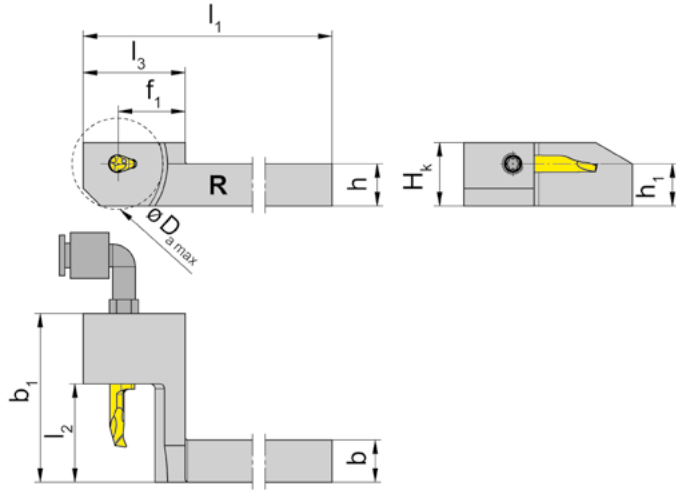
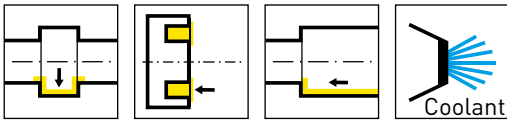

R = right hand version shown

L = left hand version

Part number	h	b	l ₁	l ₃	h ₁	b ₁	f ₁	D _{a max}	H _K	l ₂	HWS
RHCU105.0375.21	.375	.375	3.898	1.142	.375	1.496	.748	1.024	.611	.709	105123 • 105124 • 105125
RHCU105.0375.41	.375	.375	3.898	1.142	.375	1.890	.748	1.024	.611	1.102	105123 • 105124 • 105125
RHCU105.0500.21	.500	.500	3.898	1.142	.500	1.496	.748	1.024	.736	.709	105123 • 105124 • 105125
RHCU105.0500.41	.500	.500	3.898	1.142	.500	1.890	.748	1.024	.736	1.102	105123 • 105124 • 105125
RHCU105.0625.21	.625	.625	4.094	1.339	.625	1.496	.945	1.417	.861	.709	105123 • 105124 • 105125
RHCU105.0625.41	.625	.625	4.094	1.339	.625	1.890	.945	1.417	.861	1.102	105123 • 105124 • 105125

Dimensions in inch



Spare Parts

Note: setup inserts are located at the end of the chapter

Toolholder	Coolant Fitting	Clamping Screw	TORX PLUS® Wrench	Torque Value
RHCU105...	KQ2L06-M5, M5x5.0	6.075T15P	T15PQ	5 Nm

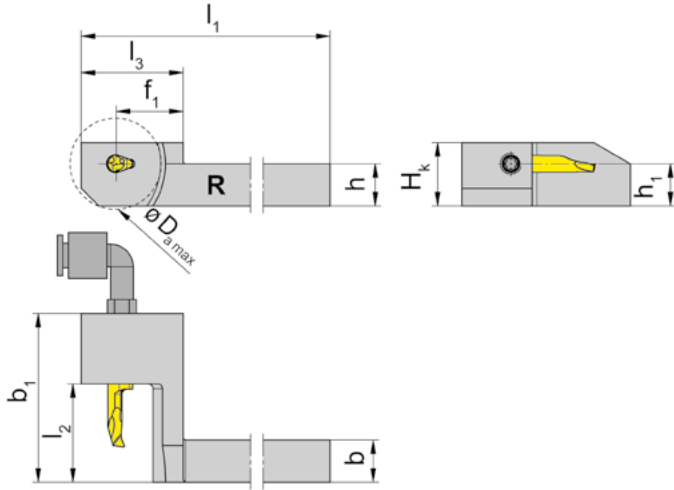
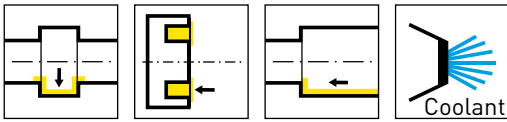

R = right hand version shown

L = left hand version

Part number	h	b	l ₁	l ₃	h ₁	b ₁	f ₁	D _{a max}	H _k	l ₂	HWS
RHC105.0808.21	8	8	99	29	8	32	19	26	13	18	105123 • 105124 • 105125
RHC105.1010.11	10	10	99	29	10	22.7	19	26	16	8	105123 • 105124 • 105125
RHC105.1010.21	10	10	99	29	10	38	19	26	16	18	105123 • 105124 • 105125
RHC105.1010.41	10	10	99	29	10	48	19	26	16	28	105123 • 105124 • 105125
RHC105.1212.21	12	12	99	29	12	38	19	26	18	18	105123 • 105124 • 105125
RHC105.1212.41	12	12	99	29	12	48	19	26	18	28	105123 • 105124 • 105125
RHC105.1616.21	16	16	104	34	16	38	24	36	22	18	105123 • 105124 • 105125
RHC105.1616.41	16	16	104	34	16	48	24	36	22	28	105123 • 105124 • 105125
LHC105.0808.21	8	8	99	29	8	32	19	26	13	18	105123 • 105124 • 105125
LHC105.1212.21	12	12	99	29	12	38	19	26	18	18	105123 • 105124 • 105125
LHC105.1616.21	16	16	104	34	16	38	24	36	22	18	105123 • 105124 • 105125

R/LHC105.0808.21 and RHC105.1010.11 do not have through coolant

Dimensions in mm

Spare Parts

Note: setup inserts are located at the end of the chapter

Toolholder	Coolant Fitting	Clamping Screw	TORX PLUS® Wrench	Torque Value
R/LHC105...	KQ2L06-M5, M5x5.0	6.075T15P	T15PQ	5 Nm

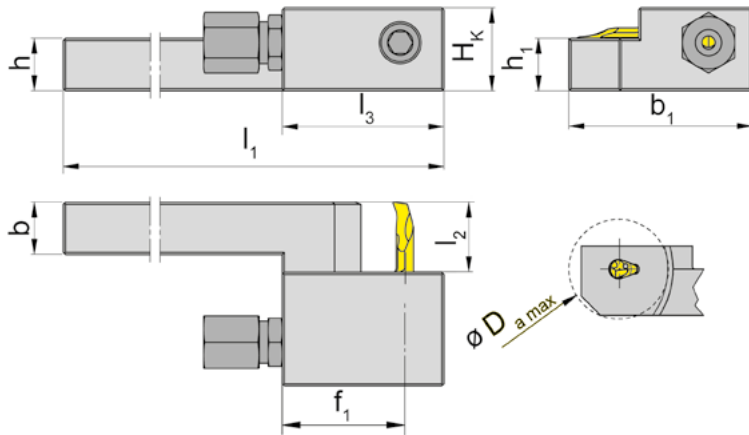
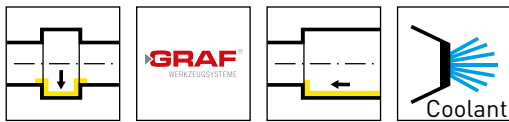

Picture = right hand insert shown

Part number	h	b	f ₁	l ₁	l ₃	h ₁	H _k	b ₁	l ₂	D _{a max}	HWS
962.08.01.R.IK	8	8	27	130	37	8	15	42	18	30	105123 • 105124 • 105125
962.08.02.L.IK	8	8	27	130	37	8	15	42	18	30	105123 • 105124 • 105125
962.10.01.R.IK	10	10	27	130	37	10	17	42	18	30	105123 • 105124 • 105125
962.10.02.L.IK	10	10	27	130	37	10	17	42	18	30	105123 • 105124 • 105125
962.10.03.R.IK	10	10	27	130	37	10	17	57	33	30	105123 • 105124 • 105125
962.10.04.L.IK	10	10	27	130	37	10	7	57	33	30	105123 • 105124 • 105125
962.12.01.R.IK	12	12	27	130	37	12	19	42	18	30	105123 • 105124 • 105125
962.12.02.L.IK	12	12	27	130	37	12	19	42	18	30	105123 • 105124 • 105125
962.12.03.R.IK	12	12	27	130	37	12	19	57	33	30	105123 • 105124 • 105125
962.12.04.L.IK	12	12	27	130	37	12	19	57	33	30	105123 • 105124 • 105125
962.16.01.R.IK	16	16	27	130	37	16	23	42	18	34	105123 • 105124 • 105125
962.16.02.L.IK	16	16	27	130	37	16	23	42	18	34	105123 • 105124 • 105125
962.16.03.R.IK	16	16	27	130	37	16	23	57	33	34	105123 • 105124 • 105125
962.16.04.L.IK	16	16	27	130	37	16	23	57	33	34	105123 • 105124 • 105125
962.20.01.R.IK	20	20	27	130	37	20	27	42	18	34	105123 • 105124 • 105125
962.20.02.L.IK	20	20	27	130	37	20	27	42	18	34	105123 • 105124 • 105125

Dimensions in mm

Spare Parts

Toolholder	Coolant Fitting	Clamping Screw	TORX PLUS® Wrench	Torque Value
RHCU105...	004.00.19, M8x1 internal	6.075T15P	T15PQ	5 Nm

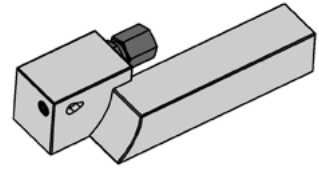
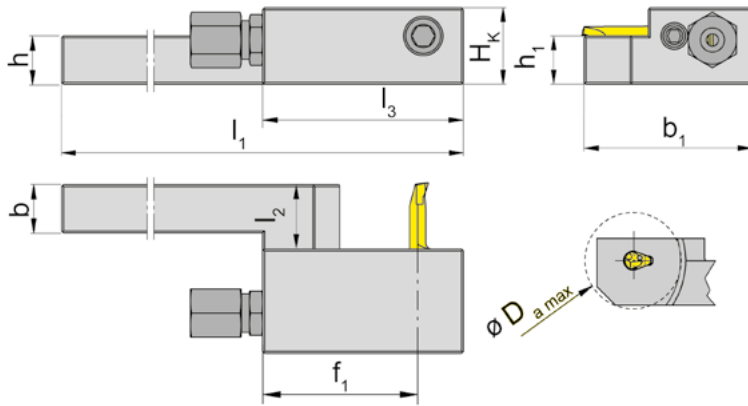
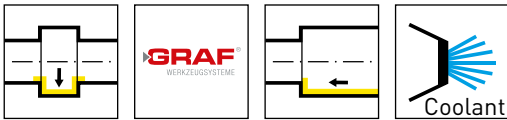

Picture = right hand insert shown

Part number	h	b	f ₁	l ₁	l ₃	h ₁	H _k	b ₁	l ₂	D _{a max}	HWS
963.12.01.R.IK	12	12	40	130	50	12	19	42	18	46	105123 • 105124 • 105125
963.12.02.L.IK	12	12	40	130	50	12	19	42	18	46	105123 • 105124 • 105125
963.16.01.R.IK	16	16	45	130	50	16	23	42	18	52	105123 • 105124 • 105125
963.16.02.L.IK	16	16	45	130	50	16	23	42	18	52	105123 • 105124 • 105125

Dimensions in mm

Spare Parts

Toolholder	Coolant Fitting	Clamping Screw	TORX PLUS® Wrench	Torque Value
RHCU105...	004.00.19, M8x1 internal	6.075T15P	T15PQ	5 Nm

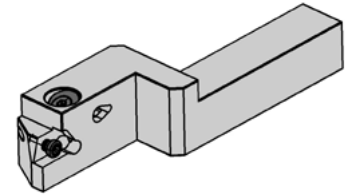
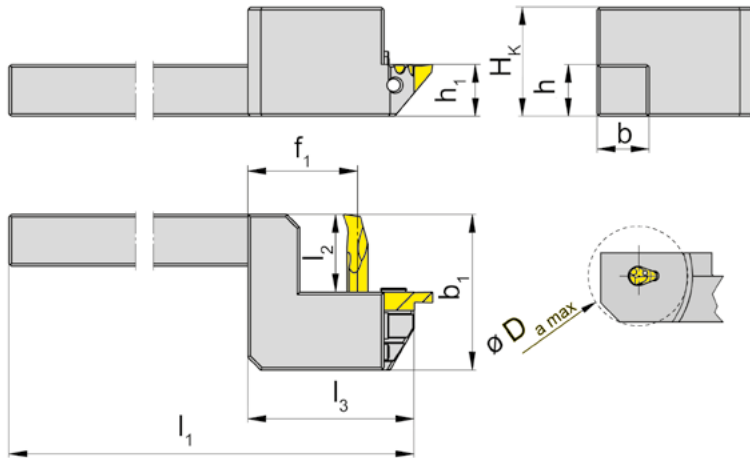

Picture = right hand insert shown

Part number	h	b	f ₁	l ₁	l ₃	h ₁	H _k	b ₁	l ₂	D _{a max}	HWS
AIH.974.R.1212.K04	12	12	23	130	50	12	19	33	16.5	20	105123 • 105124 • 105125 • 274040R
AIH.974.R.1616.K04	16	16	26	130	50	16	23	33	16.5	26	105123 • 105124 • 105125 • 274040R
AIH.974.R.2020.K04	20	20	29	130	55	20	27	33	16.5	32	105123 • 105124 • 105125 • 274040R

Dimensions in mm

Spare Parts

Note: setup inserts are located at the end of the chapter

Toolholder	Clamping Screw	TORX PLUS® Wrench	Torque Value
AIH...	6.075T15P	T15PQ	5 Nm

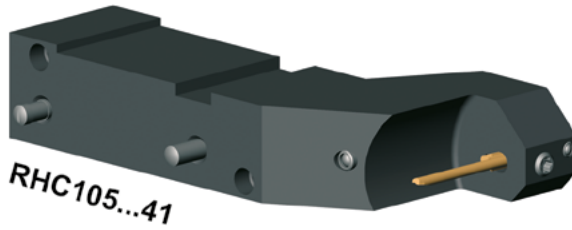
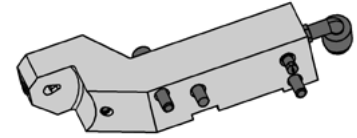
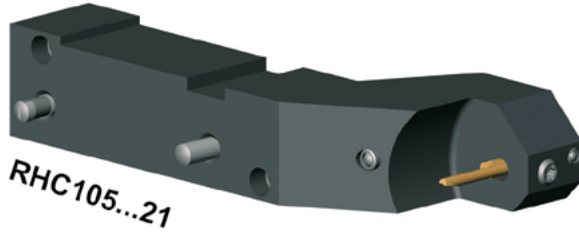
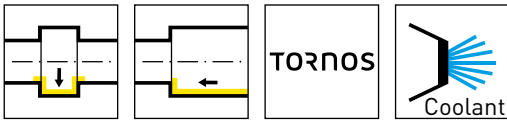

Part number	Machine type	HWS	HMS
RHC105.0710.21	EvoDECO 10	105123 • 105124 • 105125	Tornos
RHC105.0710.41	EvoDECO 10	105123 • 105124 • 105125	Tornos

Dimensions in mm

Spare Parts

Note: setup inserts are located at the end of the chapter

Basic toolholder	Clamping Screw	TORX PLUS® Wrench	Torque Value
RHC105...	6.075T15P	T15PQ	5 Nm

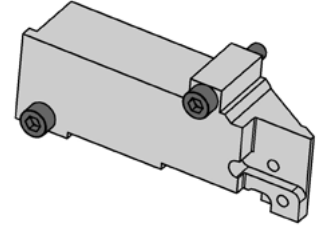
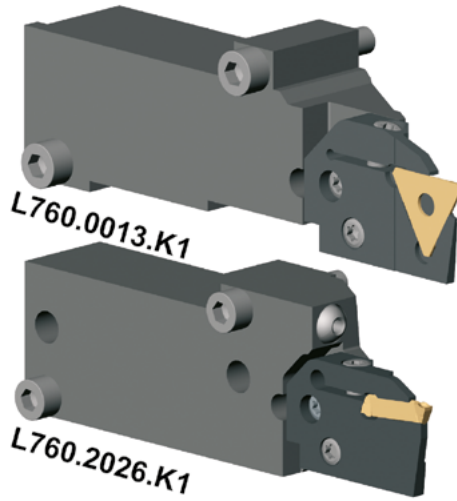
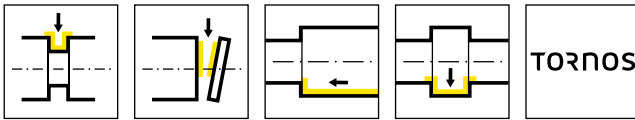

Part number	Machine type
L760.0013.K1	EvoDECO 16
L760.2026.K1	EvoDECO 20/EvoDECO 32

Dimensions in mm

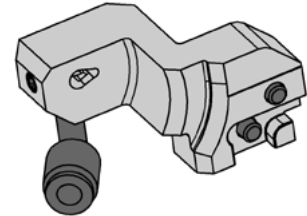
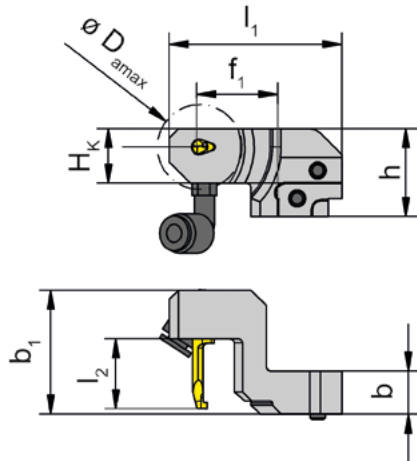
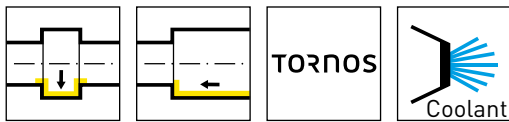

Picture = right hand insert shown

Part number	l_1	l_2	b_1	b	h	H_k	f_1	$D_{a\ max}$	HWS
RKC760.0105.21	57	24.9	40.9	14.2	29	18	26	28	105123 • 105124 • 105125
RKC760.0105.41	57	34.9	50.9	14.2	29	18	26	28	105123 • 105124 • 105125

Dimensions in mm

Spare Parts

Note: setup inserts are located at the end of the chapter

Cassette	Coolant Fitting	Clamping Screw	TORX PLUS® Wrench	Torque Value
RKC760...	KQ2L06-M5, M5x5.0	5.12T20P	T15PQ	6 Nm

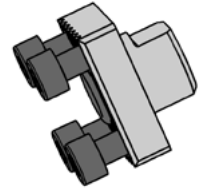
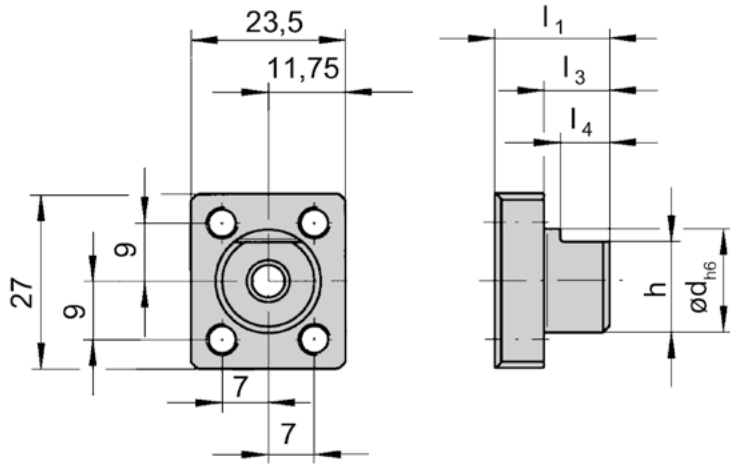
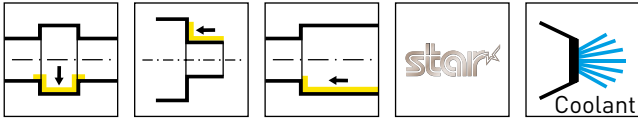

Part number	h	d	l_1	l_3	l_4	Machine type	HMS
BGT001.1627.10	14	16	17.5	10	7.5	Star	Gear Spline 90° / T3

Dimensions in mm

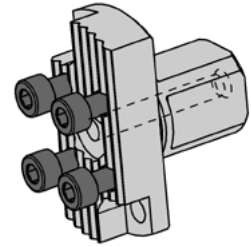
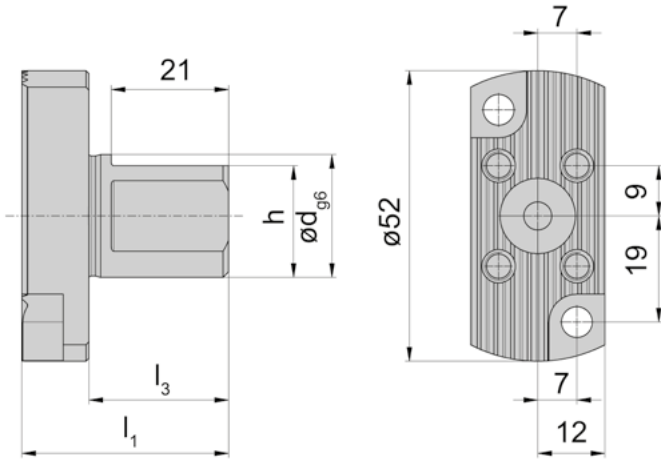
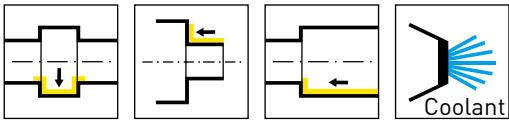

Part number	h	d	l ₁	l ₃	l ₄	HMS
BGT001.0R22.25	20	22	37	25	21	Gear Spline 90° / T3

Dimensions in mm

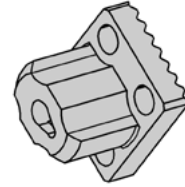
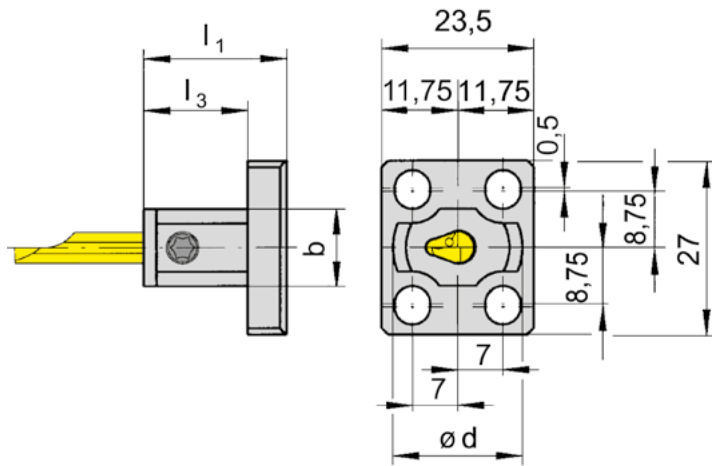
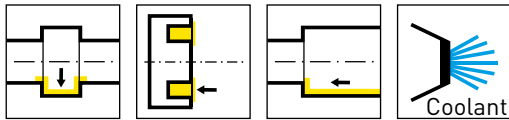

Picture = right hand insert shown

Part number	d	l ₁	l ₃	b	HWS	HMS
BKT105.2327.01	20	22	16	12	105123 • 105124 • 105125	Gear Spline 90° / T3

Dimensions in mm

Spare Parts

Note: setup inserts are located at the end of the chapter

Adjustable holder	Clamping Screw	TORX PLUS® Wrench	Torque Value
BKT105.2327.01	6.075T15P	T15PQ	5 Nm

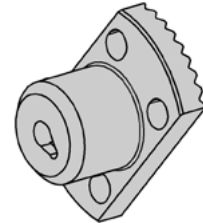
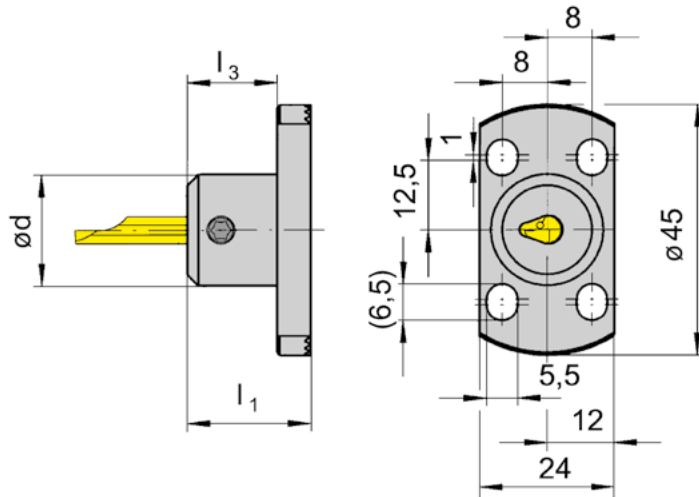
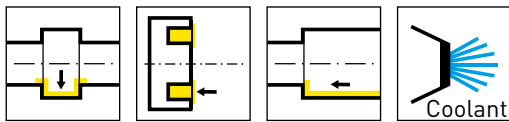

Part number	d	l_1	l_3	HWS	HMS
BKT105.2445.01	20	22	16	105123 • 105124 • 105125	Gear Spline 90° / T3
BKT105.2445.02	20	32	26	105225	Gear Spline 90° / T3

Dimensions in mm

Spare Parts

Note: setup inserts are located at the end of the chapter

Adjustable holder	Clamping Screw	TORX PLUS® Wrench	Torque Value
BKT105...	6.075T15P	T15PQ	5 Nm

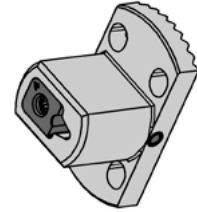
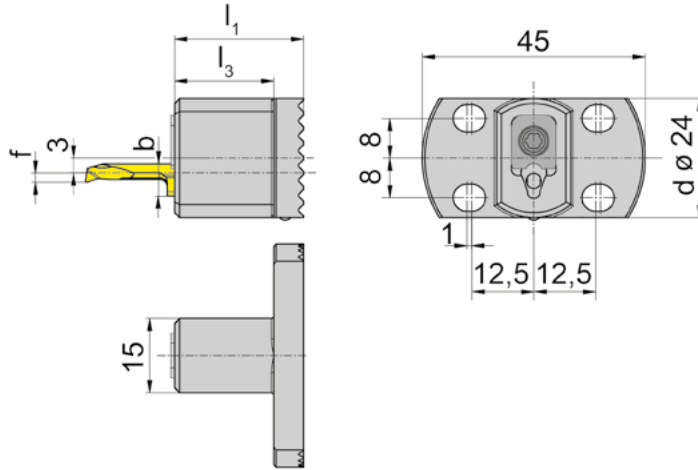
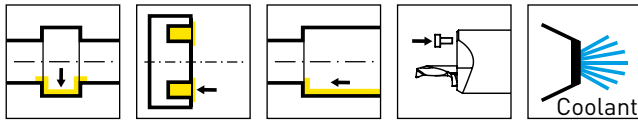

Picture = right hand insert shown

Part number	l_1	d	l_3	b	HWS	HMS
BKT105.2445.S.03	26	24	20	5.9	105123	Gear Spline 90° / T3
BKT105.2445.S.04	26	24	20	6.4	105124	Gear Spline 90° / T3
BKT105.2445.S.05	26	24	20	7	105125	Gear Spline 90° / T3

Face clamping holders with ".S" only include the clamp size associated with the holder's HWS code. Other clamp sizes must be purchased separately

Dimensions in mm

Spare Parts

Note: setup inserts are located at the end of the chapter

Toolholder	Clamping screw	Clamping element	TORX PLUS® Wrench	Torque Value
BKT105.2445.S.03	030.0000.1157	010.0105.03	T15PL	2 Nm
BKT105.2445.S.04	030.0000.1157	010.0105.04	T15PL	2 Nm
BKT105.2445.S.05	030.0000.1157	010.0105.05	T15PL	2 Nm

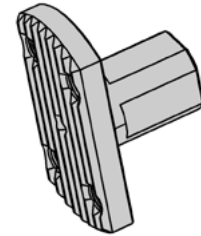
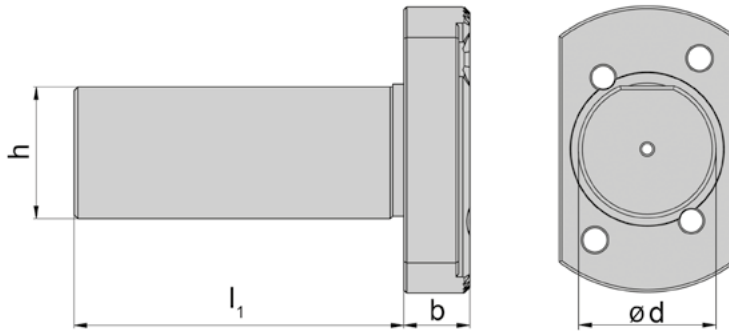
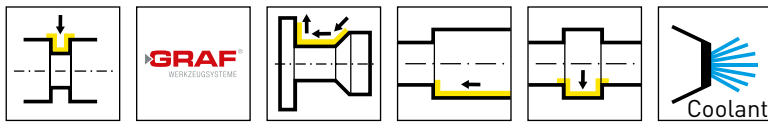

Part number	d	l ₁	h	b	Machine type
G.016.021	16	21	14	6	Star
G.016.040	16	40	14	6	Traub/Manurhin
G.034.040	3/4"	40	18	6	Citizen
G.034.050	3/4"	50	18	6	Citizen
G.034.120	3/4"	120	18	6	Citizen
G.020.030	20	30	18	6	Citizen
G.020.040	20	40	18	6	Citizen
G.020.100	20	100	18	6	Citizen
G.020.150	20	150	18	6	Citizen
G.022.023	22	23	20	6	Star
G.022.030	22	30	20	6	Star
G.022.070	22	70	20	6	Star
G.025.070	25	70	23	6	Manurhin/Tornos
G.025.100	25	100	23	6	Manurhin/Tornos
G.025.160	25	160	23	6	Manurhin/Tornos
G.010.060	1"	60	23	6	Citizen
G.010.100	1"	100	23	6	Citizen
G.028.006	28	6	26	6	Hanwha
G.028.080	28	80	26	12	Traub
G.034.020	34	20	32	12	Maier
G.034.044	34	44	32	12	Maier/Hanwha

Dimensions in mm unless stated otherwise

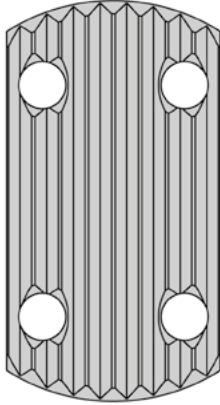

A

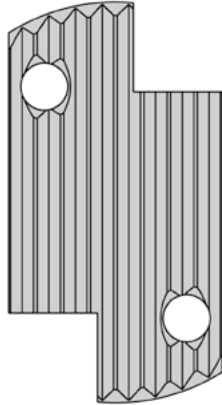

B

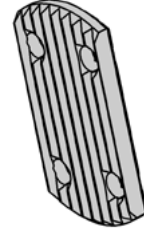
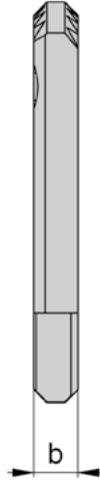

Part number	b	Form
Z.5	5	A
Z.10	10	A
Z.15	15	A
Z.20	20	A
Z.25	25	A
Z.30	30	A



Graf back working tools

Suitable for Graf type N and HORN BKT105.2445.01/02 and BKT105.2445.S.03/04/05

Part number **N11**

2 cartridge capacity

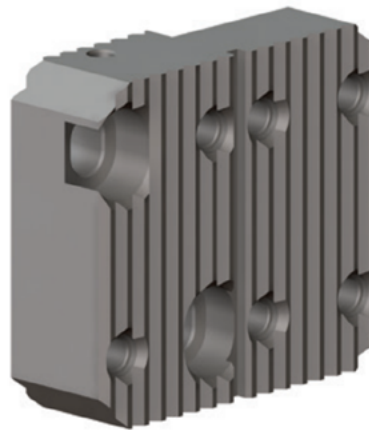

Part number **N12**

3 cartridge capacity

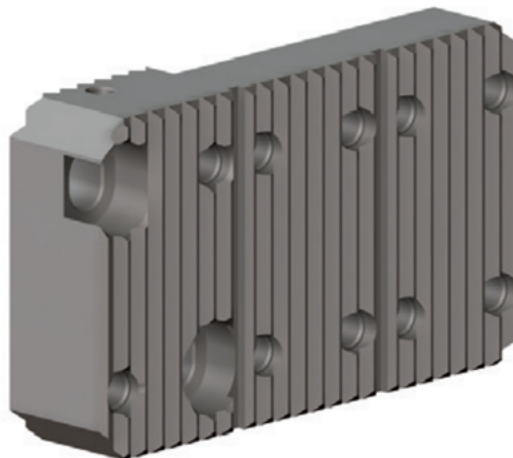

Part number **N93IK**

With coolant supply

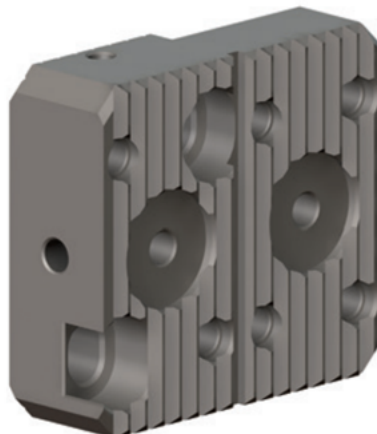

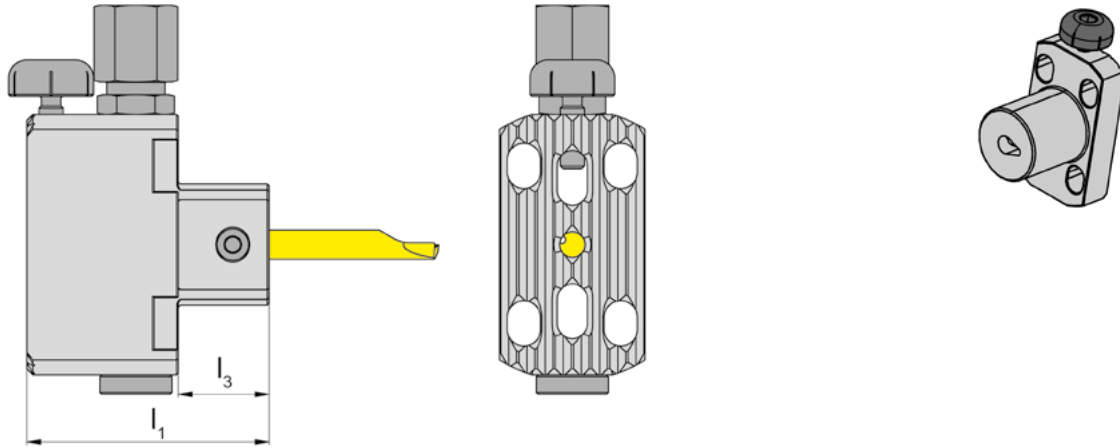
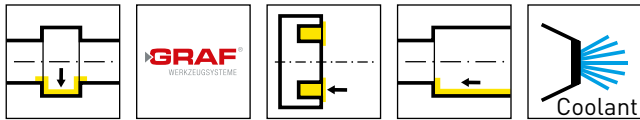

Picture = right hand insert shown

Part number	l_1	l_3	HWS
N.09.IK	40	15	105123 • 105124 • 105125

Coolant tube is not included - separate order required

Dimensions in mm

Spare Parts

Note: setup inserts are located at the end of the chapter

Adjustable holder	Coolant Supply	Clamping Screw	Torque Value
N.09.IK	004.00.19, M8x1 internal	6.075T15P	5 Nm

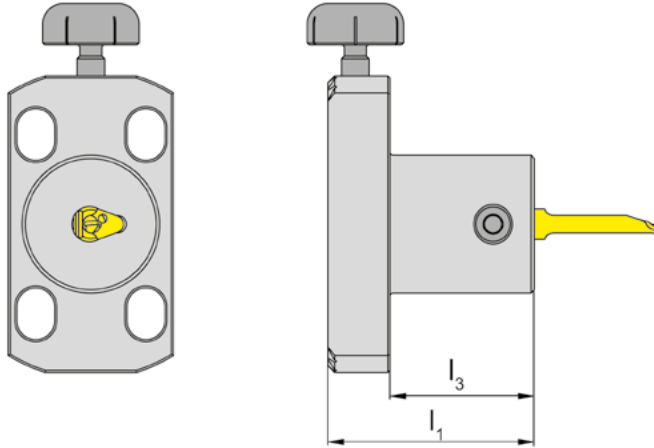
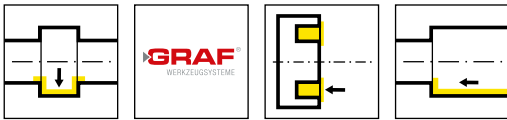

Picture = right hand insert shown

Part number	l_1	l_3	HWS
N.09	30	20	105123 • 105124 • 105125

Dimensions in mm

Spare Parts

Note: setup inserts are located at the end of the chapter

Adjustable holder	Clamping Screw	Torque Value
N.09	6.075T15P	5 Nm

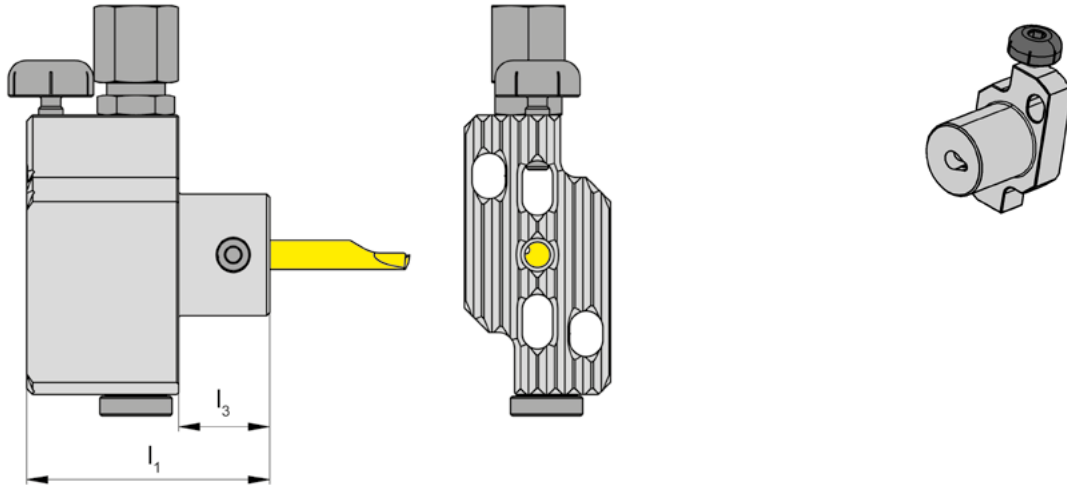
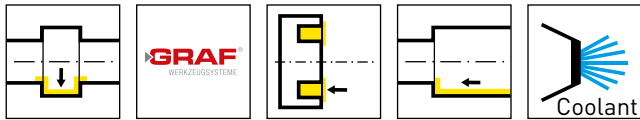

Picture = right hand insert shown

Part number	l_1	l_3	HWS
N.73.IK	40	15	105123 • 105124 • 105125

Coolant tube is not included - separate order required

Dimensions in mm

Spare Parts

Note: setup inserts are located at the end of the chapter

Adjustable holder	Coolant Supply	Clamping Screw	Torque Value
N.73.IK	004.00.19, M8x1 internal	6.075T15P	5 Nm

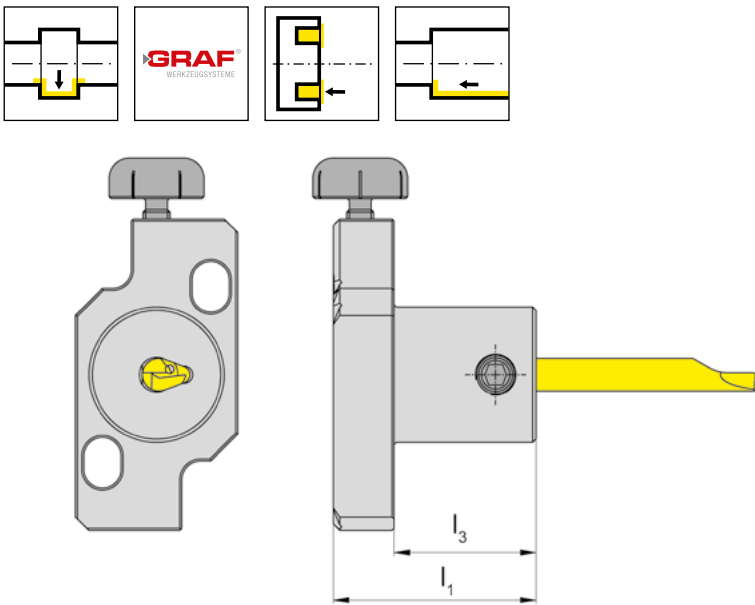

Picture = right hand insert shown

Part number	l_1	l_3	HWS
N.73	30	20	105123 • 105124 • 105125

Dimensions in mm

Spare Parts

Note: setup inserts are located at the end of the chapter

Adjustable holder	Clamping Screw	Torque Value
N.73	6.075T15P	5 Nm

Standard connection for coolant supply for pipe \varnothing 6 mm

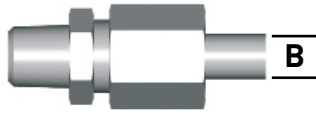

Coolant connection, straight

Part number	A	B
004.00.19	M8 x 1	\varnothing 6 mm
004.00.14	G1/8"	\varnothing 6 mm

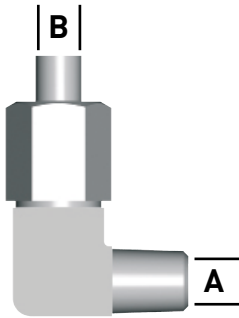

Coolant connection, angled

Part number	A	B
004.00.22	M8 x 1	\varnothing 6 mm
004.00.33	G1/8"	\varnothing 6 mm

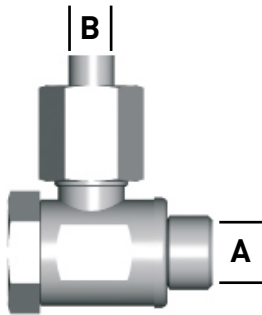

Coolant connection, swivel

Part number	A	B
004.00.61	M8 x 1	\varnothing 6 mm
004.00.16	G1/8"	\varnothing 6 mm

Quick-change connection for coolant supply

Quick connector

M10 x 1 - 004.00.49

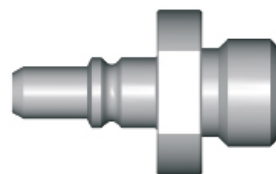

Plug

 M8 x 1 - 004.00.56
 G1/8" - 004.00.57

Plug

 \varnothing 6 mm - 004.00.59

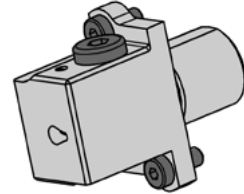
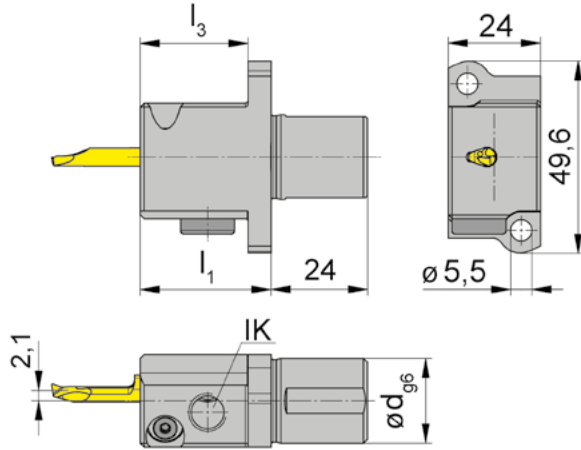
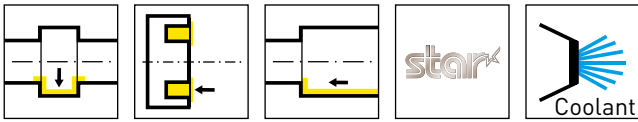

L = left hand version

Part number	d	l ₁	l ₃	HWS	HMS
LB105.A022.26.31	22	35	29	105123 • 105124 • 105125	Star

For Star Machines:
 ECAS-12/20, SB16D/E, SR-20, SR20J/JN, RS-20RII, RS-20RIII, RS-20RIV, RS-32J/JN, SW-12RII

Spare Parts

Note: setup inserts are located at the end of the chapter

Toolholder	Mounting Screws	Coolant Connection	Clamping screw	TORX PLUS® Wrench
LB105.A022.26.31	DIN7984-M5x12	18.908 (DIN908-G1-8)	070.0010.0118	T10PL

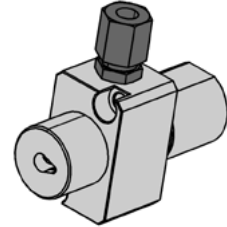
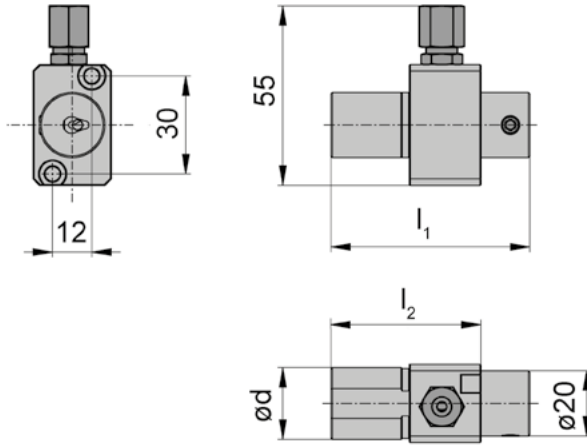
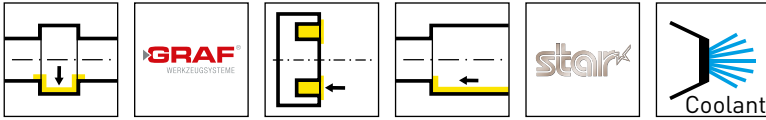

Part number	d	l_1	l_2	HWS
RHF.N.145.H105.S1.IK	22	61	46	105123 • 105124 • 105125

Coolant tube is not included - separate order required

For Star Machine: SW-20

Dimensions in mm

Spare Parts

Note: setup inserts are located at the end of the chapter

Adjustable holder	Coolant Supply	Clamping Screw	Torque Value
N.73.IK	004.00.19, M8x1 internal	001.01.36	5 Nm

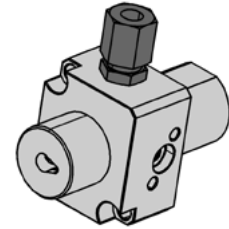
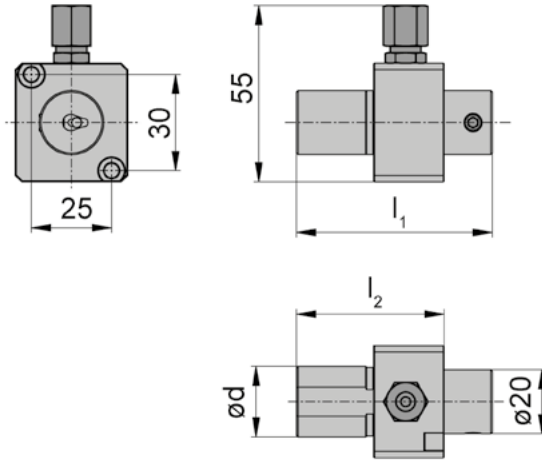
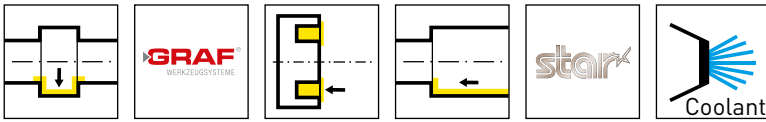

R = right hand version

Part number	d	l ₁	l ₂	HWS
RHF.N.151.H105.S2.IK	22	61	46	105123 • 105124 • 105125

Coolant tube is not included - separate order required

For Star Machine: SW-20

Dimensions in mm

Spare Parts

Note: setup inserts are located at the end of the chapter

Adjustable holder	Coolant Supply	Clamping Screw	Torque Value
N.73.IK	004.00.19, M8x1 internal	001.01.36	5 Nm

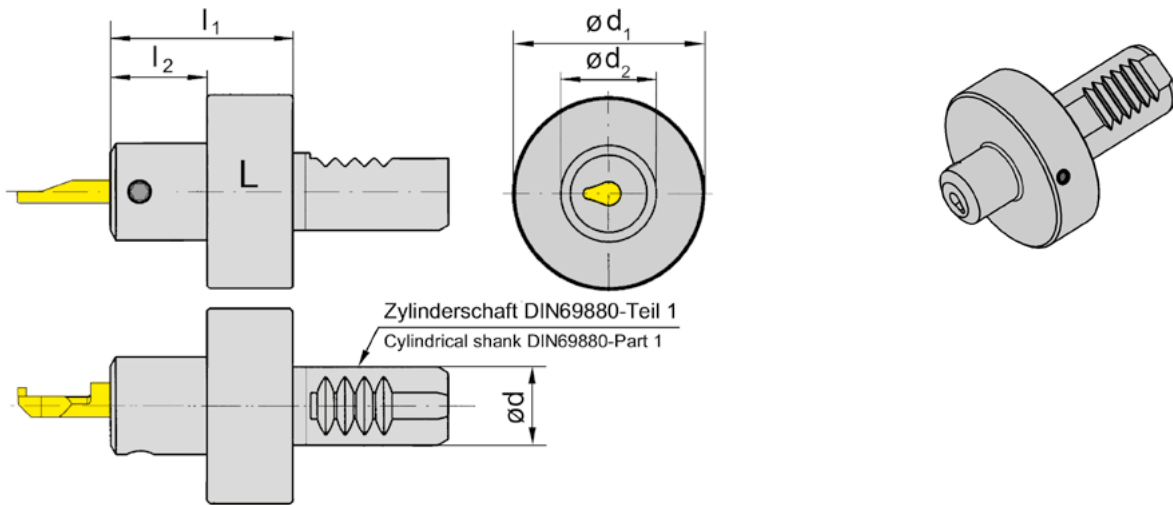
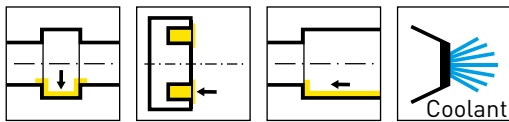

Picture = right hand insert shown

Part number	d	l ₁	l ₂	d ₂	d ₁	HWS
VDI16.R105.20.01	16	38	20	20	40	105123 • 105124 • 105125
VDI20.R105.20.01	20	38	20	20	50	105123 • 105124 • 105125
VDI25.R105.20.01	25	38	20	20	58	105123 • 105124 • 105125
VDI30.R105.20.01	30	38	20	20	68	105123 • 105124 • 105125
VDI40.R105.20.01	40	38	20	20	83	105123 • 105124 • 105125
VDI16.L105.20.01	16	38	20	20	40	105123 • 105124 • 105125
VDI20.L105.20.01	20	38	20	20	50	105123 • 105124 • 105125
VDI25.L105.20.01	25	38	20	20	58	105123 • 105124 • 105125
VDI30.L105.20.01	30	38	20	20	68	105123 • 105124 • 105125
VDI40.L105.20.01	40	38	20	20	83	105123 • 105124 • 105125

Dimensions in mm

Spare Parts

Note: setup inserts are located at the end of the chapter

Toolholder	Clamping Screw	TORX PLUS® Wrench	Torque Value
VDI16...	6.075T15P	T15PQ	5 Nm

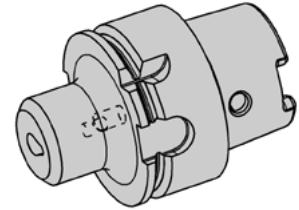
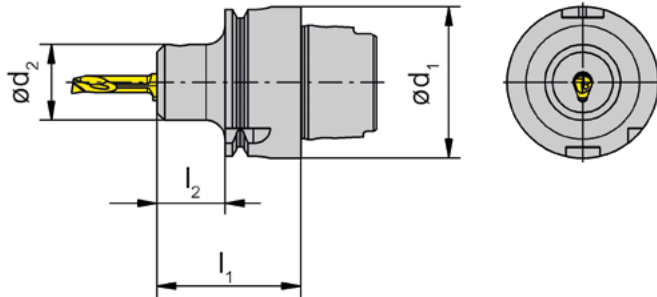
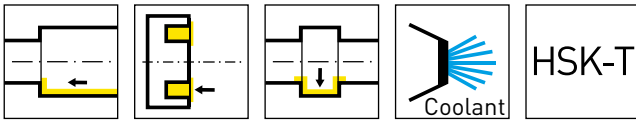

Picture = right hand insert shown

Part number	d_1	l_1	l_2	d_2	HWS
HSKT40.RB105.20.1.01	40	38	18	20	105123 • 105124 • 105125

Dimensions in mm

Spare Parts

Note: setup inserts are located at the end of the chapter

Toolholder	Clamping Screw	TORX PLUS® Wrench	Torque Value
HSKT40.RB105.20.1.01	6.075T15P	T15PQ	5 Nm

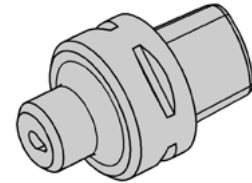
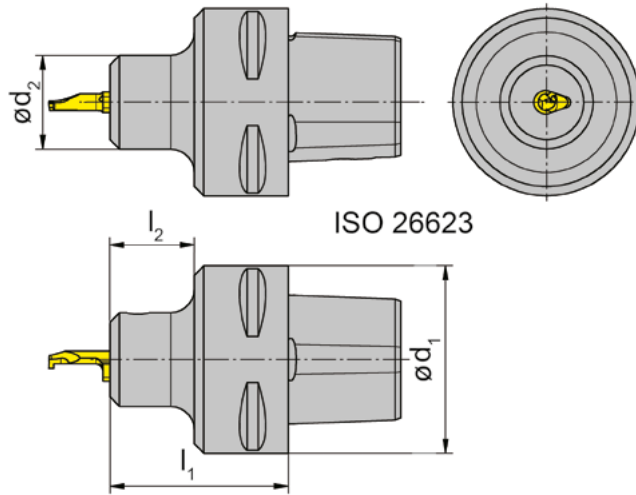
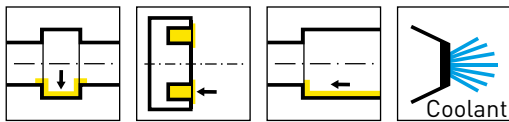

R = right hand version shown

L = left hand version

Part number	d_1	d_2	l_1	l_2	HWS
RB105.00C3.20.1.01	32	20	30	15	105123 • 105124 • 105125
RB105.00C4.20.1.01	40	20	38	18	105123 • 105124 • 105125
RB105.00C5.20.1.01	50	20	38	18	105123 • 105124 • 105125
RB105.00C6.20.1.01	63	20	52	30	105123 • 105124 • 105125
LB105.00C3.20.1.01	32	20	30	15	105123 • 105124 • 105125
LB105.00C4.20.1.01	40	20	38	18	105123 • 105124 • 105125
LB105.00C5.20.1.01	50	20	38	18	105123 • 105124 • 105125
LB105.00C6.20.1.01	63	20	52	30	105123 • 105124 • 105125

Polygonal shank according to ISO 26623

Dimensions in mm

Spare Parts

Note: setup inserts are located at the end of the chapter

Toolholder	Clamping Screw	TORX PLUS® Wrench	Torque Value
R/LB105...	6.075T15P	T15PQ	5 Nm

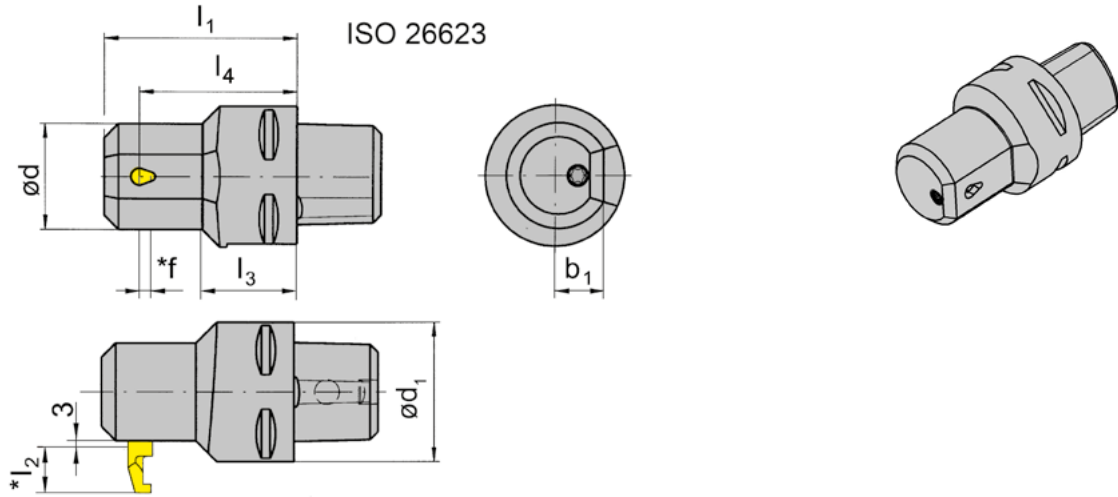
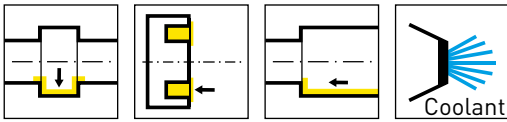

R = right hand version shown

Part number	d_1	l_3	d	l_1	l_4	b_1	HWS
RB105.00C3.2.2.01	32	17	30	55	45	14	105123 • 105124 • 105125
RB105.00C3.2.2.02	32	15	36	55	45	18	105123 • 105124 • 105125
RB105.00C4.2.2.01	40	26	30	55	45	14	105123 • 105124 • 105125
RB105.00C4.2.2.02	40	22	36	55	45	18	105123 • 105124 • 105125

Polygonal shank according to ISO 26623

f, l2 see inserts type 105

Dimensions in mm

Spare Parts

Note: setup inserts are located at the end of the chapter

Toolholder	Clamping Screw	TORX PLUS® Wrench	Torque Value
RB105...	6.075T15P	T15PQ	5 Nm

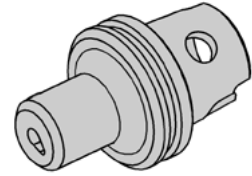
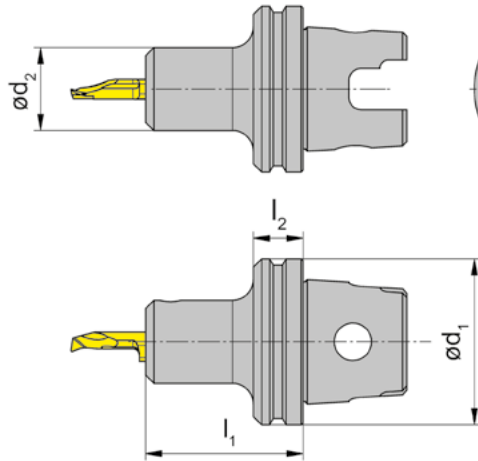
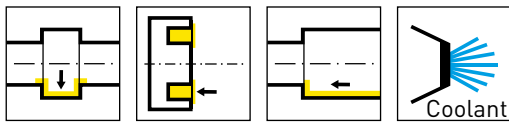

R = right hand version shown

L = left hand version

Part number	d_1	d_2	l_1	l_2	HWS
RB105.TS40.20.1.01	40	20	38	26	105123 • 105124 • 105125
LB105.TS40.20.1.01	40	20	38	26	105123 • 105124 • 105125

Dimensions in mm

Spare Parts

Note: setup inserts are located at the end of the chapter

Toolholder	Clamping Screw	TORX PLUS® Wrench	Torque Value
R/LB105.TS40.20.1.01	6.075T15P	T15PQ	5 Nm

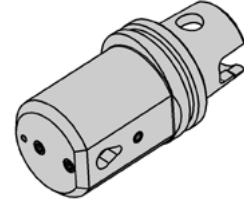
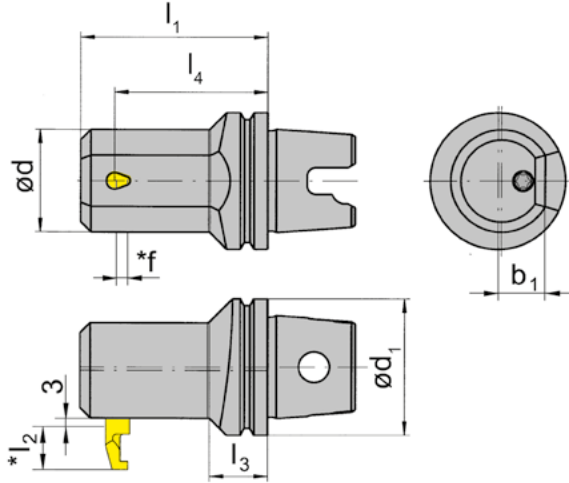
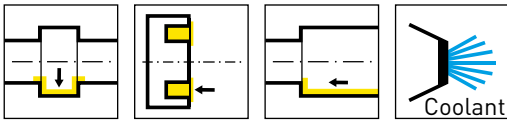

R = right hand version shown

L = left hand version

Part number	d ₁	l ₃	d	l ₁	l ₄	b ₁	HWS
RB105.TS40.2.2.01	40	17	30	55	45	14	105123 • 105124 • 105125
RB105.TS40.2.2.02	40	14	36	55	45	18	105123 • 105124 • 105125
RB105.TS50.2.2.01	50	26	30	55	45	14	105123 • 105124 • 105125
RB105.TS50.2.2.02	50	22	36	55	45	18	105223 • 105224 • 105225

Dimensions in mm

Spare Parts

Note: setup inserts are located at the end of the chapter

Toolholder	Clamping Screw	TORX PLUS® Wrench	Torque Value
RB105...	6.075T15P	T15PQ	5 Nm

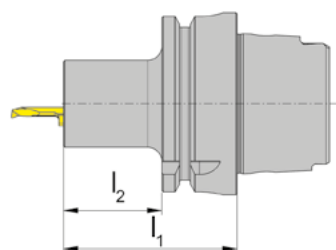
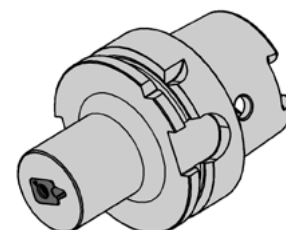
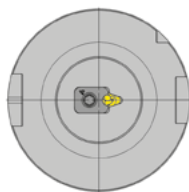
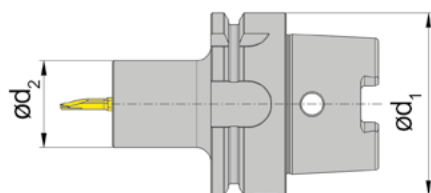
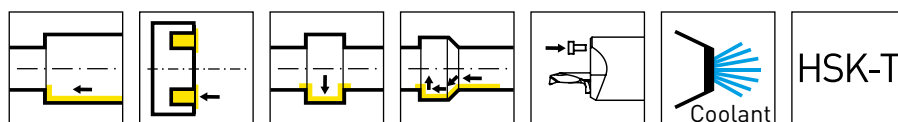

R = right hand version shown

L = left hand version

Part number	d ₁	l ₁	l ₂	d ₂	HWS
RB105.HSKT63.S.03	63	60	34	30	105123
RB105.HSKT63.S.04	63	60	34	30	105124
RB105.HSKT63.S.05	63	60	34	30	105125
LB105.HSKT63.S.03	63	60	34	30	105123
LB105.HSKT63.S.04	63	60	34	30	105124
LB105.HSKT63.S.05	63	60	34	30	105125

Face clamping holders with ".S" only include the clamp size associated with the holder's HWS code. Other clamp sizes must be purchased separately

Dimensions in mm

Spare Parts

Note: setup inserts are located at the end of the chapter

Toolholder	Clamping screw	Clamping element	TORX PLUS® Wrench	Torque Value
R/LB105.HSKT63.S.03	030.0000.1157	010.0105.03	T15PL	2 Nm
R/LB105.HSKT63.S.04	030.0000.1157	010.0105.04	T15PL	2 Nm
R/LB105.HSKT63.S.05	030.0000.1157	010.0105.05	T15PL	2 Nm

Toolholder

B105.HSKT

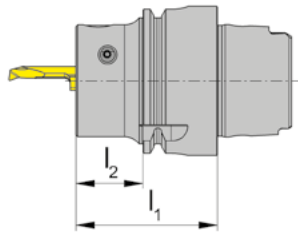
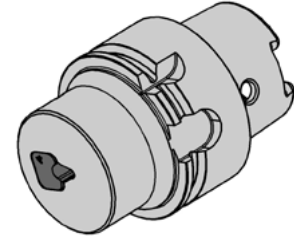
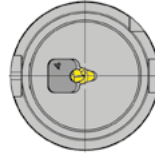
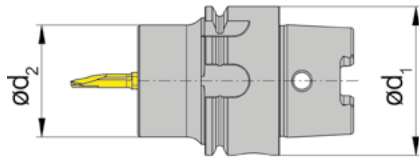
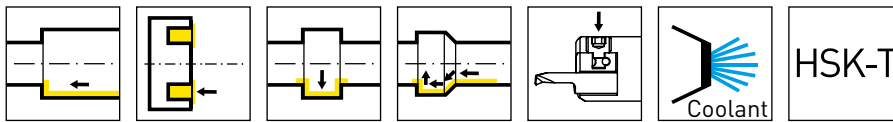

R = right hand version shown

L = left hand version

Part number	d_1	l_1	l_2	d_2	HWS
RB105.HSKT40.A.03	40	38	18	30	105123
RB105.HSKT40.A.04	40	38	18	30	105124
RB105.HSKT40.A.05	40	38	18	30	105125
LB105.HSKT40.A.03	40	38	18	30	105123
LB105.HSKT40.A.04	40	38	18	30	105124
LB105.HSKT40.A.05	40	38	18	30	105125

Top clamping holders with ".A" only include the clamp size associated with the holder's HWS code. Other clamp sizes must be purchased separately

Dimensions in mm

Spare Parts

Note: setup inserts are located at the end of the chapter

Toolholder	Clamping Screw	Clamping element	TORX PLUS® Wrench	Torque Value
R/LB105.HSKT40.A.03	030.00M8.1188	010.0003.0668	T25PQ	4 Nm
R/LB105.HSKT40.A.04	030.00M8.1188	010.0004.0667	T25PQ	4 Nm
R/LB105.HSKT40.A.05	030.00M8.1188	010.0005.0663	T25PQ	4 Nm

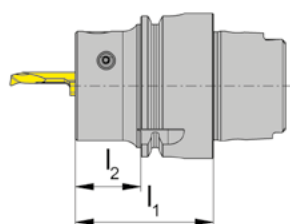
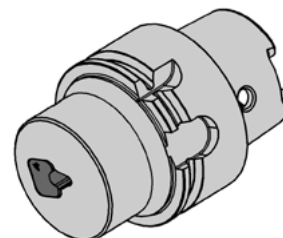
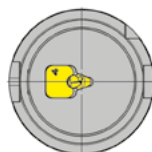
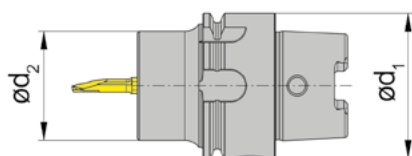
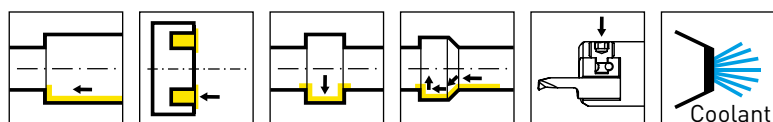

R = right hand version shown

Part number	d_1	l_1	l_2	d_2	HWS
RB105.HSKA40.A.03.BU	40	38	18	30	105123
RB105.HSKA40.A.04.BU	40	38	18	30	105124
RB105.HSKA40.A.05.BU	40	38	18	30	105125

Top clamping holders with ".A" only include the clamp size associated with the holder's HWS code. Other clamp sizes must be purchased separately

Suitable for Bumotec machines

Dimensions in mm

Spare Parts

Note: setup inserts are located at the end of the chapter

Toolholder	Clamping screw	Clamping element	TORX PLUS® Wrench	Torque Value
RB105.HSKA40.A.03.BU	030.00M8.1188	010.0003.0668	T25PQ	4 Nm
RB105.HSKA40.A.04.BU	030.00M8.1188	010.0004.0667	T25PQ	4 Nm
RB105.HSKA40.A.05.BU	030.00M8.1188	010.0005.0663	T25PQ	4 Nm

Toolholder

B105.HSKE

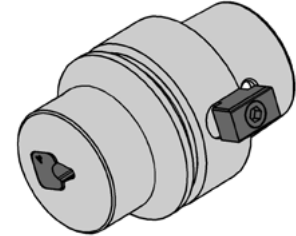
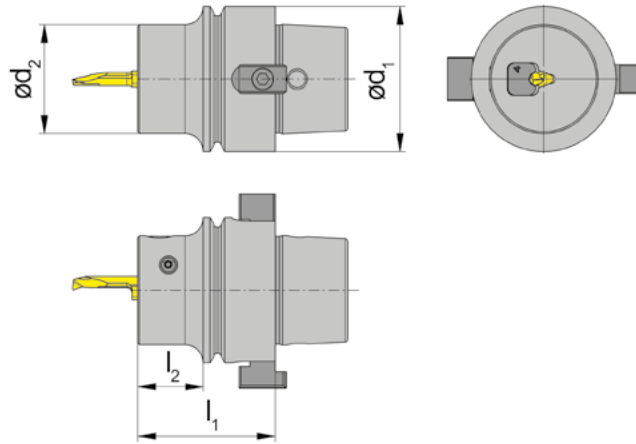
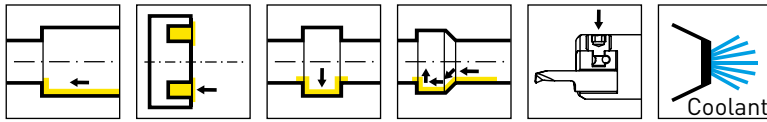

R = right hand version shown

L = left hand version

Part number	d_1	l_1	l_2	d_2	HWS
RB105.HSKE40.A.03.WM	40	38	18	30	105123
RB105.HSKE40.A.04.WM	40	38	18	30	105124
RB105.HSKE40.A.05.WM	40	38	18	30	105125
LB105.HSKE40.A.03.WM	40	38	18	30	105123
LB105.HSKE40.A.04.WM	40	38	18	30	105124
LB105.HSKE40.A.05.WM	40	38	18	30	105125

Top clamping holders with ".A" only include the clamp size associated with the holder's HWS code. Other clamp sizes must be purchased separately

Suitable for Willemin-Macodel machines

Dimensions in mm

Spare Parts

Note: setup inserts are located at the end of the chapter

Toolholder	Clamping screw	Clamping element	TORX PLUS® Wrench	Torque Value
R/LB105.HSKE40.A.03.WM	030.00M8.1188	010.0003.0668	T25PQ	4 Nm
R/LB105.HSKE40.A.04.WM	030.00M8.1188	010.0004.0667	T25PQ	4 Nm
R/LB105.HSKE40.A.05.WM	030.00M8.1188	010.0005.0663	T25PQ	4 Nm

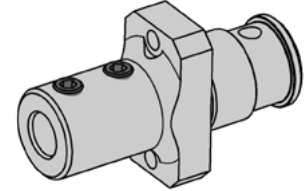
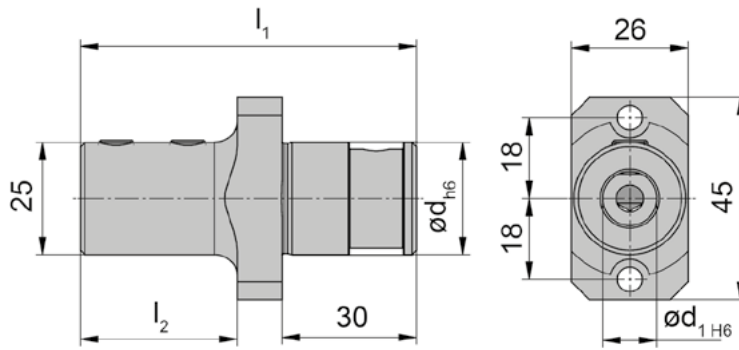
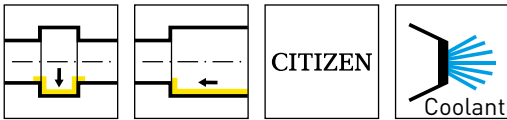

Part number	d	l_1	d_1	l_2	Machine type
001.C025.12.30IK	25	75	12	35	Citizen L20X/

Dimensions in mm

Spare Parts

Note: setup inserts are located at the end of the chapter

Boring Bar Adapter	Clamping Screw	Torque Value
001.C025.12.30IK	8.075.1835	5 Nm

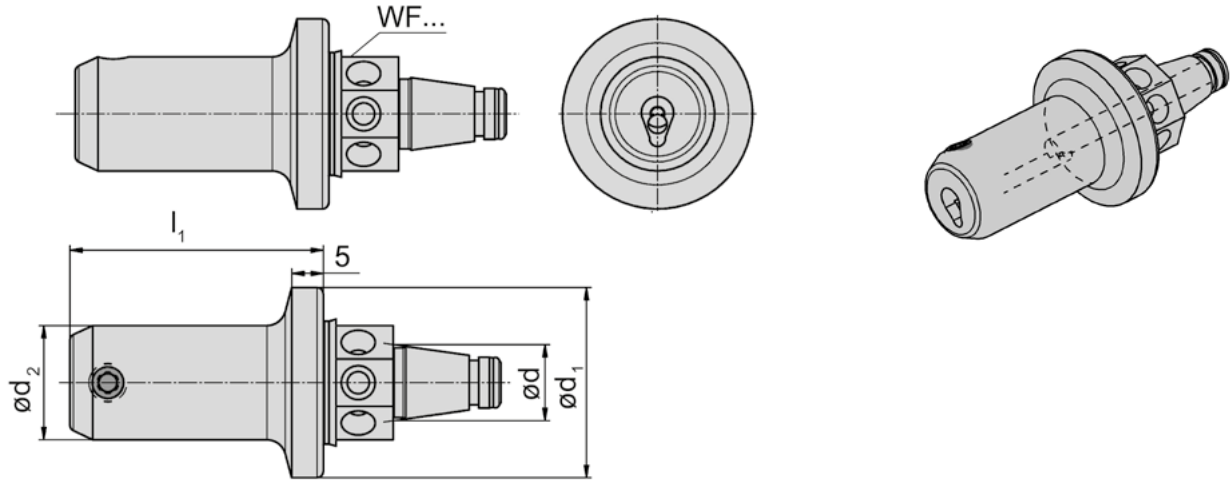
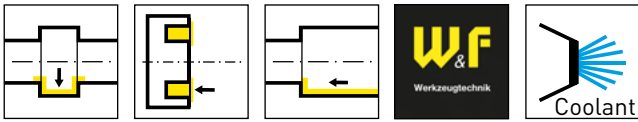

Part number	d ₁	l ₁	d	d ₂	HWS	HMS
WFB.2H0.105	30	40	12	18	105123 • 105124 • 105125	WFB
WFB.2H0.105.055	30	55	12	18	105123 • 105124 • 105125	WFB
WFB.3H0.105	50	40	20	18	105123 • 105124 • 105125	WFB
WFB.3H0.105.055	50	55	20	18	105123 • 105124 • 105125	WFB

For more W&F holder options, see our catalog - W&F Modular Technology for Swiss Type Machines

Dimensions in mm

Spare Parts

Note: setup inserts are located at the end of the chapter

Toolholder	Clamping Screw	TORX PLUS® Wrench	Torque Value
WFB...	6.075T15P	T15PQ	5 Nm

Multi-Function for Drilling, Boring, Facing, and OD Turning

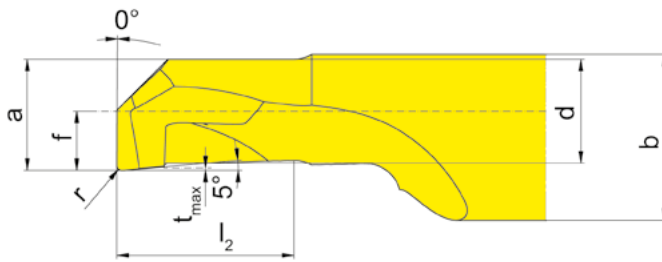
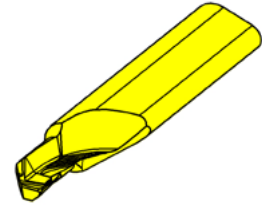
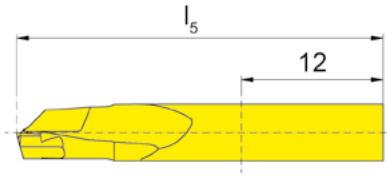
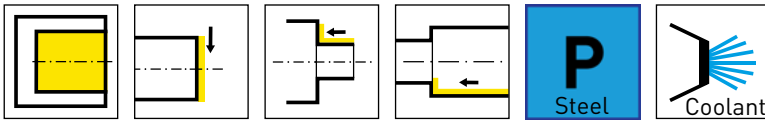

Coating grades

R = right hand version shown

L = left hand version

▲ In stock

△ 2 weeks

Part number	r	f	a	d	b	l ₂	l ₅	t _{max}	Ds	HIS	EG35
R105.BO.30.20.045.1	0.2	1.5	2.7	2.4	7	4.5	31	0.1	3	105125	▲
R105.BO.30.20.075.1	0.2	1.5	2.7	2.4	7	7.5	31	0.1	3	105125	▲
R105.BO.40.20.060.1	0.2	2	3.7	3.4	7	6	31	0.1	4	105125	▲
R105.BO.40.20.100.1	0.2	2	3.7	3.4	7	10	31	0.1	4	105125	▲
R105.BO.50.20.075.1	0.2	2.5	4.7	4.4	7	7.5	31	0.1	5	105125	▲
R105.BO.50.20.125.1	0.2	2.5	4.7	4.4	7	12.5	36	0.1	5	105125	▲
R105.BO.60.20.090.1	0.2	3	5.4	5.1	7	9	31	0.1	6	105125	▲
R105.BO.60.20.150.1	0.2	3	5.4	5.1	7	15	36	0.1	6	105125	▲
R105.BO.70.20.105.1	0.2	3.5	5.9	5.6	7	10.5	36	0.1	7	105125	▲
R105.BO.70.20.175.1	0.2	3.5	5.9	5.6	7	17.5	40	0.1	7	105125	▲
L105.BO.30.20.045.1	0.2	1.5	2.7	2.4	7	4.5	31	0.1	3	105125	▲
L105.BO.30.20.075.1	0.2	1.5	2.7	2.4	7	7.5	31	0.1	3	105125	▲
L105.BO.40.20.060.1	0.2	2	3.7	3.4	7	6	31	0.1	4	105125	▲
L105.BO.40.20.100.1	0.2	2	3.7	3.4	7	10	31	0.1	4	105125	▲
L105.BO.50.20.075.1	0.2	2.5	4.7	4.4	7	7.5	31	0.1	5	105125	▲
L105.BO.50.20.125.1	0.2	2.5	4.7	4.4	7	12.5	36	0.1	5	105125	▲
L105.BO.60.20.090.1	0.2	3	5.4	5.1	7	9	31	0.1	6	105125	▲
L105.BO.60.20.150.1	0.2	3	5.4	5.1	7	15	36	0.1	6	105125	▲
L105.BO.70.20.105.1	0.2	3.5	5.9	5.6	7	10.5	36	0.1	7	105125	▲
L105.BO.70.20.175.1	0.2	3.5	5.9	5.6	7	17.5	40	0.1	7	105125	▲

These inserts feature a chipbreaker geometry that is optimized for chip control in difficult and long-chipping materials. Drilling performance is best in general steels. See pages 447-448 "Chapter M - Geometries for R/L105.BO" for more information.

Internal coolant from Ds 5 mm and above, no internal coolant for Ds 3-4 mm.

Dimensions in mm

P	●
M	●
K	●
N	○
S	-
H	-

Multi-Function for Drilling, Boring, Facing, and OD Turning

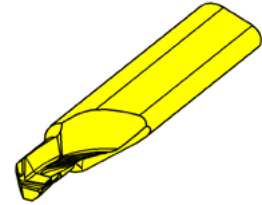
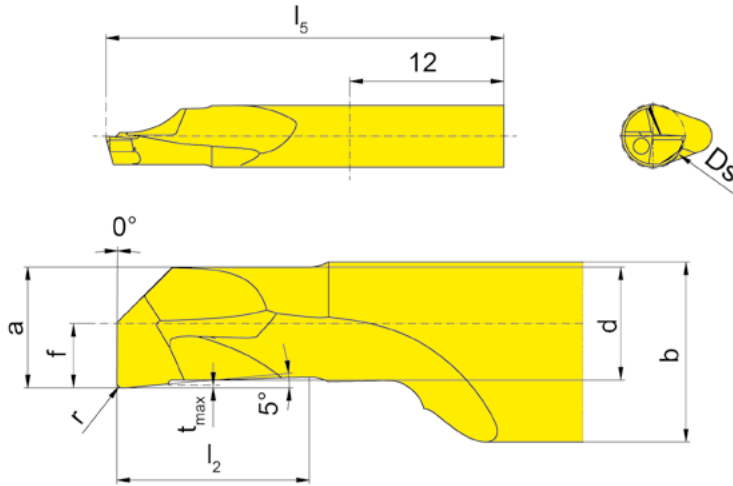
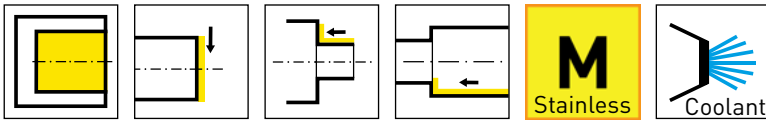

Coating grades

R = right hand version shown

L = left hand version

▲ In stock

△ 2 weeks

Part number	r	f	a	d	b	l ₂	l ₅	t _{max}	Ds	HIS	EG35
R105.BO.30.20.045.2	0.2	1.5	2.7	2.4	7	4.5	31	0.1	3	105125	▲
R105.BO.30.20.075.2	0.2	1.5	2.7	2.4	7	7.5	31	0.1	3	105125	▲
R105.BO.40.20.060.2	0.2	2	3.7	3.4	7	6	31	0.1	4	105125	▲
R105.BO.40.20.100.2	0.2	2	3.7	3.4	7	10	31	0.1	4	105125	▲
R105.BO.50.20.075.2	0.2	2.5	4.7	4.4	7	7.5	31	0.1	5	105125	▲
R105.BO.50.20.125.2	0.2	2.5	4.7	4.4	7	12.5	36	0.1	5	105125	▲
R105.BO.60.20.090.2	0.2	3	5.4	5.1	7	9	31	0.1	6	105125	▲
R105.BO.60.20.150.2	0.2	3	5.4	5.1	7	15	36	0.1	6	105125	▲
R105.BO.70.20.105.2	0.2	3.5	5.9	5.6	7	10.5	36	0.1	7	105125	▲
R105.BO.70.20.175.2	0.2	3.5	5.9	5.6	7	17.5	40	0.1	7	105125	▲
L105.BO.30.20.045.2	0.2	1.5	2.7	2.4	7	4.5	31	0.1	3	105125	▲
L105.BO.30.20.075.2	0.2	1.5	2.7	2.4	7	7.5	31	0.1	3	105125	▲
L105.BO.40.20.060.2	0.2	2	3.7	3.4	7	6	31	0.1	4	105125	▲
L105.BO.40.20.100.2	0.2	2	3.7	3.4	7	10	31	0.1	4	105125	▲
L105.BO.50.20.075.2	0.2	2.5	4.7	4.4	7	7.5	31	0.1	5	105125	▲
L105.BO.50.20.125.2	0.2	2.5	4.7	4.4	7	12.5	36	0.1	5	105125	▲
L105.BO.60.20.090.2	0.2	3	5.4	5.1	7	9	31	0.1	6	105125	▲
L105.BO.60.20.150.2	0.2	3	5.4	5.1	7	15	36	0.1	6	105125	▲
L105.BO.70.20.105.2	0.2	3.5	5.9	5.6	7	10.5	36	0.1	7	105125	▲
L105.BO.70.20.175.2	0.2	3.5	5.9	5.6	7	17.5	40	0.1	7	105125	▲

These inserts feature a universal geometry that is optimized for drilling in steel, stainless, and non-ferrous materials. The geometry also creates low cutting pressure, excellent for thin walls.

See pages 447-448 "Chapter M - Geometries for R/L105.BO" for more information.

Internal coolant from Ds 5 mm and above, no internal coolant for Ds 3-4 mm.

Dimensions in mm

P	●
M	●
K	●
N	○
S	-
H	-

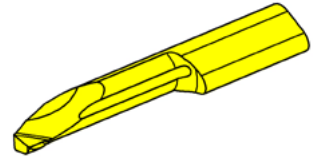
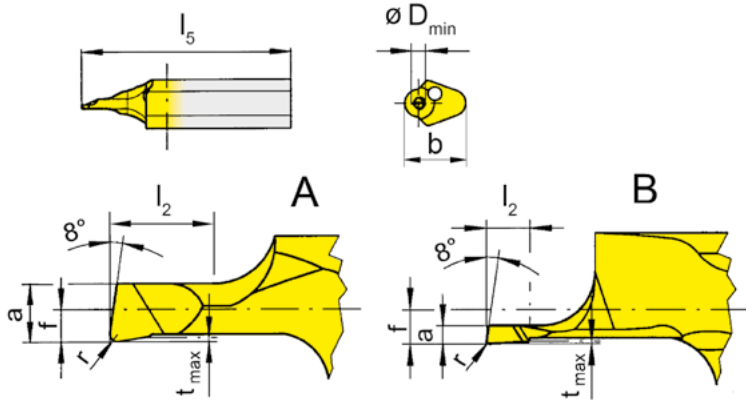
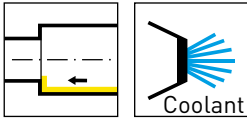

Coating grades

R = right hand version shown

L = left hand version

▲ In stock

Δ 2 weeks

Part number	r	f	a	b	l ₂	l ₅	t _{max}	D _{min}	Form	HIS	Coating grades	
											EG35	IG35
R105.1802.0.02	0.02	1	0.17	5.9	1	23	0.02	0.2	B	105123	Δ	
R105.1802.0.03	0.02	1	0.25	5.9	1	23	0.02	0.3	B	105123	Δ	
R105.1802.0.05	0.05	1	0.4	5.9	2	23	0.05	0.5	B	105123	Δ	▲
R105.1803.0.07	0.05	0.3	0.6	5.9	2	23	0.05	0.7	A	105123	▲	▲
L105.1802.0.02	0.02	1	0.17	5.9	1	23	0.02	0.2	B	105123	Δ	
L105.1802.0.03	0.02	1	0.25	5.9	1	23	0.02	0.3	B	105123	Δ	
L105.1802.0.05	0.05	1	0.4	5.9	2	23	0.05	0.5	B	105123	Δ	
L105.1803.0.07	0.05	0.3	0.6	5.9	2	23	0.05	0.7	A	105123	Δ	

Dimensions in mm

P	●	●
M	●	●
K	●	●
N	○	○
S	-	○
H	-	-

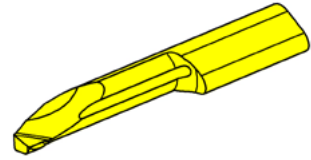
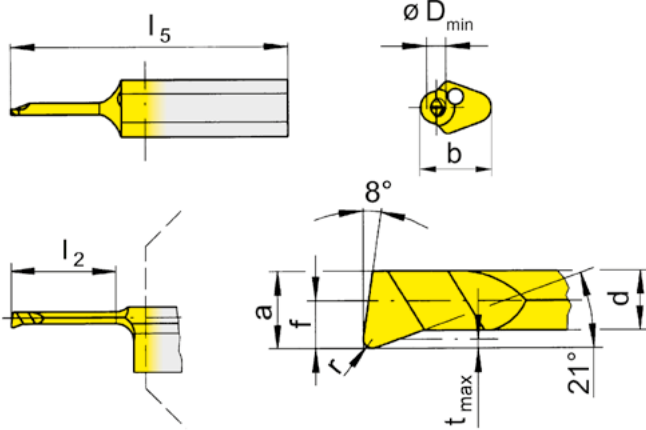
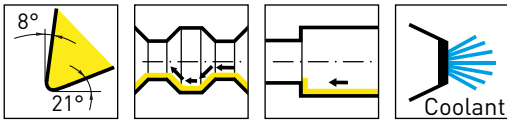

Coating grades

R = right hand version shown

L = left hand version

▲ In stock

Δ 2 weeks

Part number	r	f	a	d	b	l ₂	l ₅	t _{max}	D _{min}	HIS	Coating grades				
											EG35	IG35	TH35	TI25	TN35
R105.1805.005.0.1	0.05	0.5	0.9	0.65	5.9	4	25	0.1	1	105123	▲	▲	▲		
R105.1805.005.1.1	0.05	0.5	0.9	0.65	5.9	6	25	0.1	1	105123	▲	▲	▲		
R105.1805.005.2.1	0.05	0.5	0.9	0.65	5.9	8	25	0.1	1	105123	Δ	▲	▲		
R105.1805.0.1	0.1	0.5	0.9	0.65	5.9	4	25	0.1	1	105123	▲	▲		▲	▲
R105.1805.1.1	0.1	0.5	0.9	0.65	5.9	6	25	0.1	1	105123	▲	▲		▲	▲
R105.1805.2.1	0.1	0.5	0.9	0.65	5.9	8	25	0.1	1	105123	▲	▲		▲	▲
R105.1813.005.0.15	0.05	1.3	1.4	1.1	5.9	6	25	0.15	1.5	105123	▲	▲	▲		
R105.1813.005.1.15	0.05	1.3	1.4	1.1	5.9	9	25	0.15	1.5	105123	▲	▲	▲		
R105.1813.005.2.15	0.05	1.3	1.4	1.1	5.9	12	30	0.15	1.5	105123	▲	▲	▲		
R105.1813.01.0.15	0.1	1.3	1.4	1.1	5.9	6	25	0.15	1.5	105123	▲	▲	▲	▲	
R105.1813.01.1.15	0.1	1.3	1.4	1.1	5.9	9	25	0.15	1.5	105123	▲	▲	▲	▲	
R105.1813.01.2.15	0.1	1.3	1.4	1.1	5.9	12	30	0.15	1.5	105123	Δ	▲	▲	▲	
L105.1805.005.0.1	0.05	0.5	0.9	0.65	5.9	4	25	0.1	1	105123	Δ		▲		
L105.1805.005.1.1	0.05	0.5	0.9	0.65	5.9	6	25	0.1	1	105123	Δ		▲		
L105.1805.005.2.1	0.05	0.5	0.9	0.65	5.9	8	25	0.1	1	105123					
L105.1805.0.1	0.1	0.5	0.9	0.65	5.9	4	25	0.1	1	105123	▲			▲	▲
L105.1805.1.1	0.1	0.5	0.9	0.65	5.9	6	25	0.1	1	105123	▲			▲	▲
L105.1805.2.1	0.1	0.5	0.9	0.65	5.9	8	25	0.1	1	105123	Δ			▲	▲
L105.1813.005.0.15	0.05	1.3	1.4	1.1	5.9	6	25	0.15	1.5	105123	Δ				
L105.1813.005.1.15	0.05	1.3	1.4	1.1	5.9	9	25	0.15	1.5	105123	Δ				
L105.1813.005.2.15	0.05	1.3	1.4	1.1	5.9	12	30	0.15	1.5	105123	Δ				
L105.1813.01.0.15	0.1	1.3	1.4	1.1	5.9	6	25	0.15	1.5	105123	Δ		▲	▲	
L105.1813.01.1.15	0.1	1.3	1.4	1.1	5.9	9	25	0.15	1.5	105123	Δ		▲	▲	
L105.1813.01.2.15	0.1	1.3	1.4	1.1	5.9	12	30	0.15	1.5	105123	Δ		▲	▲	

Dimensions in mm

P	●	●	●	●	●
M	●	●	●	●	-
K	●	●	●	-	●
N	○	○	-	●	○
S	-	○	-	-	-
H	-	-	-	-	-

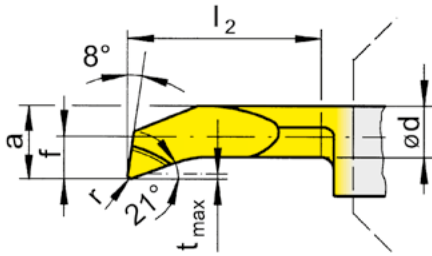
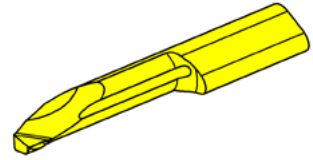
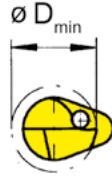
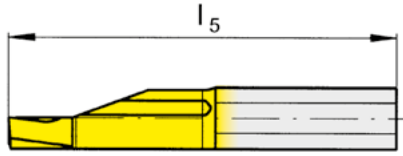
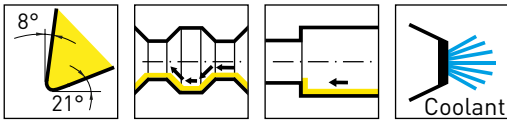

Coating grades

R = right hand version shown

L = left hand version

▲ In stock

△ 2 weeks

Part number	r	f	a	d	b	l ₂	l ₅	t _{max}	D _{min}	HIS	EG35	IG35	TH35	TI25	TN35
R105.1809.005.0.2	0.05	1	1.9	1.6	5.9	6	25	0.15	2	105123	▲	▲	▲	▲	▲
R105.1809.005.1.2	0.05	1	1.9	1.6	5.9	9	25	0.15	2	105123	△	▲	▲	▲	▲
R105.1809.005.2.2	0.05	1	1.9	1.6	5.9	12	30	0.15	2	105123	△	▲	▲	▲	▲
R105.1809.01.0.2	0.1	1	1.9	1.6	5.9	6	25	0.15	2	105123	△	▲	▲	▲	▲
R105.1809.01.1.2	0.1	1	1.9	1.6	5.9	9	25	0.15	2	105123	△	▲	▲	▲	▲
R105.1809.01.2.2	0.1	1	1.9	1.6	5.9	12	30	0.15	2	105123	△	▲	▲	▲	▲
R105.1809.0.2	0.15	1	1.9	1.6	5.9	6	25	0.15	2	105123	▲	▲	▲	▲	▲
R105.1809.1.2	0.15	1	1.9	1.6	5.9	9	25	0.15	2	105123	▲	▲	▲	▲	▲
R105.1809.2.2	0.15	1	1.9	1.6	5.9	12	30	0.15	2	105123	▲	▲	▲	▲	▲
R105.1813.005.0.25	0.05	1.3	2.3	1.95	5.9	6	25	0.15	2.5	105123	▲	▲	▲	▲	▲
R105.1813.005.1.25	0.05	1.3	2.3	1.95	5.9	9	25	0.15	2.5	105123	▲	▲	▲	▲	▲
R105.1813.005.2.25	0.05	1.3	2.3	1.95	5.9	12	30	0.15	2.5	105123	△	▲	▲	▲	▲
R105.1813.005.3.25	0.05	1.3	2.3	1.95	5.9	16	35	0.15	2.5	105123	▲	▲	▲	▲	▲
L105.1809.005.0.2	0.05	1	1.9	1.6	5.9	6	25	0.15	2	105123	△	▲	▲	▲	▲
L105.1809.005.1.2	0.05	1	1.9	1.6	5.9	9	25	0.15	2	105123	△	▲	▲	▲	▲
L105.1809.005.2.2	0.05	1	1.9	1.6	5.9	12	30	0.15	2	105123	△	▲	▲	▲	▲
L105.1809.01.0.2	0.1	1	1.9	1.6	5.9	6	25	0.15	2	105123	△	▲	▲	▲	▲
L105.1809.01.1.2	0.1	1	1.9	1.6	5.9	9	25	0.15	2	105123	△	▲	▲	▲	▲
L105.1809.01.2.2	0.1	1	1.9	1.6	5.9	12	30	0.15	2	105123	△	▲	▲	▲	▲
L105.1809.0.2	0.15	1	1.9	1.6	5.9	6	25	0.15	2	105123	▲	▲	▲	▲	▲
L105.1809.1.2	0.15	1	1.9	1.6	5.9	9	25	0.15	2	105123	▲	▲	▲	▲	▲
L105.1809.2.2	0.15	1	1.9	1.6	5.9	12	30	0.15	2	105123	▲	▲	▲	▲	▲
L105.1813.005.0.25	0.05	1.3	2.3	1.95	5.9	6	25	0.15	2.5	105123	△	▲	▲	▲	▲
L105.1813.005.1.25	0.05	1.3	2.3	1.95	5.9	9	25	0.15	2.5	105123	△	▲	▲	▲	▲
L105.1813.005.2.25	0.05	1.3	2.3	1.95	5.9	12	30	0.15	2.5	105123	△	▲	▲	▲	▲
L105.1813.005.3.25	0.05	1.3	2.3	1.95	5.9	16	35	0.15	2.5	105123	△	▲	▲	▲	▲

Dimensions in mm

P	●	●	●	●	●
M	●	●	●	●	-
K	●	●	●	-	●
N	○	○	-	●	○
S	-	○	-	-	-
H	-	-	-	-	-

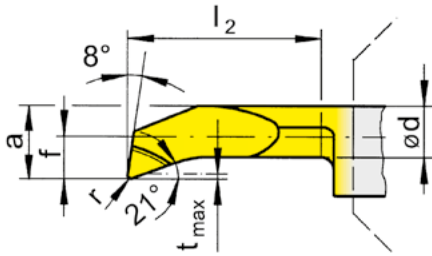
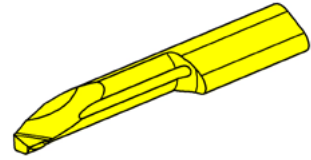
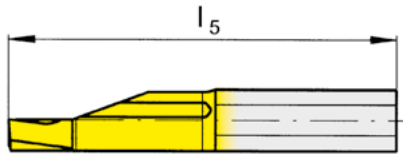
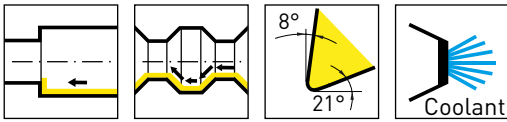

Coating grades

R = right hand version shown

L = left hand version

▲ In stock

△ 2 weeks

Part number	r	f	a	d	b	l ₂	l ₅	t _{max}	D _{min}	HIS	Coating grades					
											EG35	IG35	TF45	TH35	TI25	TN35
R105.1813.005.1.3	0.05	1.3	2.6	2.3	5.9	10	25	0.15	3	105123	▲	▲		▲	▲	▲
R105.1813.005.2.3	0.05	1.3	2.6	2.3	5.9	15	30	0.15	3	105123	△	▲		▲	▲	
R105.1813.005.3.3	0.05	1.3	2.6	2.3	5.9	20	35	0.15	3	105123	▲	▲		▲	▲	▲
R105.1813.01.1.3	0.1	1.3	2.6	2.3	5.9	10	25	0.15	3	105123	▲	▲		▲	▲	
R105.1813.01.2.3	0.1	1.3	2.6	2.3	5.9	15	30	0.15	3	105123	▲	▲		▲	▲	
R105.1813.01.3.3	0.1	1.3	2.6	2.3	5.9	20	35	0.15	3	105123	△	▲		▲	▲	
R105.1813.1.3	0.2	1.3	2.6	2.3	5.9	10	25	0.15	3	105123	▲	▲		▲	▲	▲
R105.1813.2.3	0.2	1.3	2.6	2.3	5.9	15	30	0.15	3	105123	▲	▲		▲	▲	▲
R105.1813.3.3	0.2	1.3	2.6	2.3	5.9	20	35	0.15	3	105123	▲	▲	△	▲	▲	▲
L105.1813.005.1.3	0.05	1.3	2.6	2.3	5.9	10	25	0.15	3	105123	△			▲		
L105.1813.005.2.3	0.05	1.3	2.6	2.3	5.9	15	30	0.15	3	105123	△					
L105.1813.005.3.3	0.05	1.3	2.6	2.3	5.9	20	35	0.15	3	105123	△			▲		
L105.1813.01.1.3	0.1	1.3	2.6	2.3	5.9	10	25	0.15	3	105123	△			▲	▲	
L105.1813.01.2.3	0.1	1.3	2.6	2.3	5.9	15	30	0.15	3	105123	△			▲	▲	
L105.1813.01.3.3	0.1	1.3	2.6	2.3	5.9	20	35	0.15	3	105123	△			▲	▲	
L105.1813.1.3	0.2	1.3	2.6	2.3	5.9	10	25	0.15	3	105123	▲	▲		▲	▲	▲
L105.1813.2.3	0.2	1.3	2.6	2.3	5.9	15	30	0.15	3	105123	▲	▲		▲	▲	▲
L105.1813.3.3	0.2	1.3	2.6	2.3	5.9	20	35	0.15	3	105123	▲	▲		▲	▲	▲

Dimensions in mm

P	●	●	-	●	●	●
M	●	●	-	●	●	-
K	●	●	-	●	●	●
N	○	○	-	-	●	○
S	-	○	-	-	-	-
H	-	-	-	-	-	-

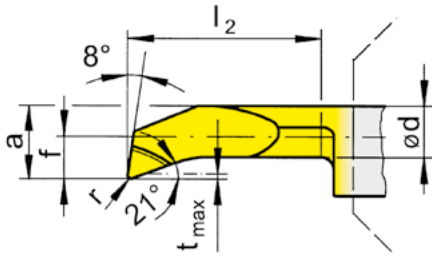
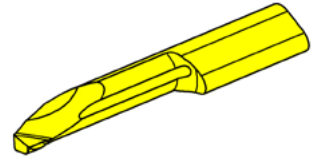
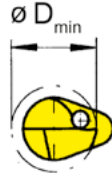
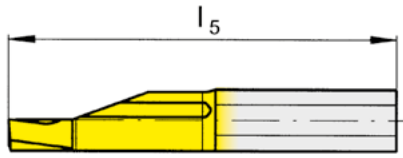
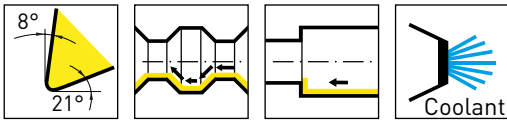

Coating grades

R = right hand version shown

L = left hand version

▲ In stock

Δ 2 weeks

Part number	r	f	a	d	b	l ₂	l ₅	t _{max}	D _{min}	HIS	Coating grades				
											EG35	IG35	TH35	TI25	TN35
R105.1819.005.1.4	0.05	1.9	3.7	2.9	6.4	10	25	0.3	4	105124	▲	▲	▲	▲	▲
R105.1819.005.2.4	0.05	1.9	3.7	2.9	6.4	15	30	0.3	4	105124	▲	▲	▲	▲	▲
R105.1819.005.3.4	0.05	1.9	3.7	2.9	6.4	20	35	0.3	4	105124	▲	▲	▲	▲	▲
R105.1819.1.4	0.2	1.9	3.7	2.9	6.4	10	25	0.3	4	105124	▲	▲	▲	▲	▲
R105.1819.2.4	0.2	1.9	3.7	2.9	6.4	15	30	0.3	4	105124	▲	▲	▲	▲	▲
R105.1819.3.4	0.2	1.9	3.7	2.9	6.4	20	35	0.3	4	105124	▲	▲	▲	▲	▲
L105.1819.005.1.4	0.05	1.9	3.7	2.9	6.4	10	25	0.3	4	105124	Δ	▲			
L105.1819.005.2.4	0.05	1.9	3.7	2.9	6.4	15	30	0.3	4	105124	Δ				
L105.1819.005.3.4	0.05	1.9	3.7	2.9	6.4	20	35	0.3	4	105124	Δ		▲		
L105.1819.1.4	0.2	1.9	3.7	2.9	6.4	10	25	0.3	4	105124	▲	▲	▲	▲	▲
L105.1819.2.4	0.2	1.9	3.7	2.9	6.4	15	30	0.3	4	105124	▲		▲	▲	▲
L105.1819.3.4	0.2	1.9	3.7	2.9	6.4	20	35	0.3	4	105124	▲		▲	▲	▲

Dimensions in mm

P	●	●	●	●	●
M	●	●	●	●	-
K	●	●	●	-	●
N	○	○	-	●	○
S	-	○	-	-	-
H	-	-	-	-	-

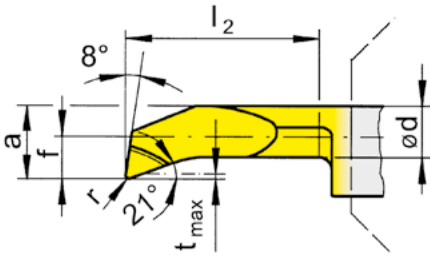
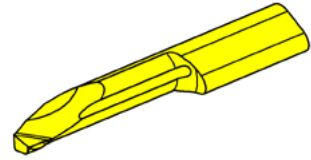
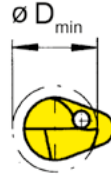
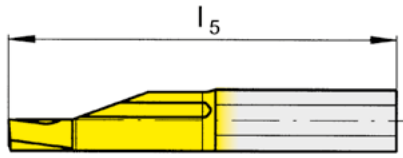
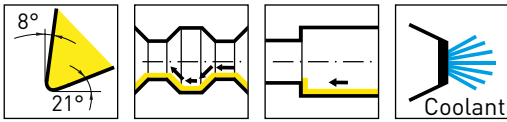

Coating grades

R = right hand version shown

L = left hand version

▲ In stock

△ 2 weeks

Part number	r	f	a	d	b	l ₂	l ₅	t _{max}	D _{min}	HIS	EG35	IG35	TH35	TI25	TN35
R105.1823.005.1.5	0.05	2.3	4.7	4	7	10	25	0.5	5	105125	△	▲	▲		
R105.1823.005.2.5	0.05	2.3	4.7	4	7	15	30	0.5	5	105125	▲	▲	▲		▲
R105.1823.005.3.5	0.05	2.3	4.7	4	7	20	35	0.5	5	105125	△	▲	▲	△	▲
R105.1823.005.4.5	0.05	2.3	4.7	4	7	25	40	0.5	5	105125	▲	▲	▲		▲
R105.1823.005.5.5	0.05	2.3	4.7	4	7	30	45	0.5	5	105125	△	▲	▲		▲
R105.1823.1.5	0.2	2.3	4.7	4	7	10	25	0.5	5	105125	▲	▲	▲	▲	▲
R105.1823.2.5	0.2	2.3	4.7	4	7	15	30	0.5	5	105125	▲	▲	▲	▲	▲
R105.1823.3.5	0.2	2.3	4.7	4	7	20	35	0.5	5	105125	▲	▲	▲	▲	▲
R105.1823.4.5	0.2	2.3	4.7	4	7	25	40	0.5	5	105125	▲	▲	▲	▲	▲
R105.1823.5.5	0.2	2.3	4.7	4	7	30	45	0.5	5	105125	▲	▲	▲	▲	▲
R105.1823.6.5	0.2	2.3	4.7	4	7	35	50	0.5	5	105125	▲	▲	▲	▲	▲
L105.1823.005.1.5	0.05	2.3	4.7	4	7	10	25	0.5	5	105125	△			△	
L105.1823.005.2.5	0.05	2.3	4.7	4	7	15	30	0.5	5	105125	△				
L105.1823.005.3.5	0.05	2.3	4.7	4	7	20	35	0.5	5	105125	△				
L105.1823.005.4.5	0.05	2.3	4.7	4	7	25	40	0.5	5	105125	▲				
L105.1823.005.5.5	0.05	2.3	4.7	4	7	30	45	0.5	5	105125	△				
L105.1823.1.5	0.2	2.3	4.7	4	7	10	25	0.5	5	105125	▲		▲	▲	▲
L105.1823.2.5	0.2	2.3	4.7	4	7	15	30	0.5	5	105125	▲	▲	▲	▲	▲
L105.1823.3.5	0.2	2.3	4.7	4	7	20	35	0.5	5	105125	▲	▲	▲	▲	▲
L105.1823.4.5	0.2	2.3	4.7	4	7	25	40	0.5	5	105125	▲		▲	▲	▲
L105.1823.5.5	0.2	2.3	4.7	4	7	30	45	0.5	5	105125	▲		▲	▲	▲

Dimensions in mm

P	●	●	●	●	●
M	●	●	●	●	-
K	●	●	●	-	●
N	○	○	-	●	○
S	-	○	-	-	-
H	-	-	-	-	-

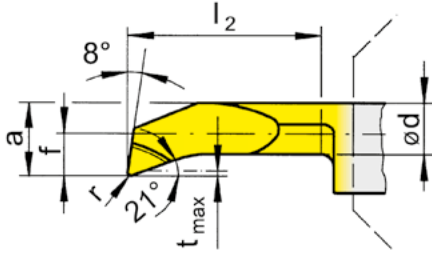
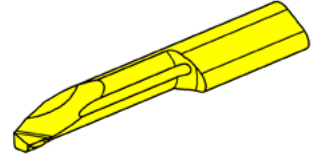
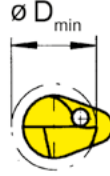
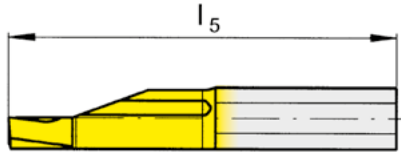
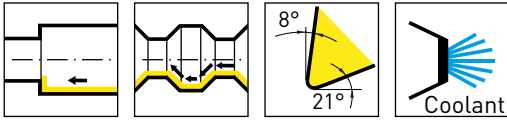

Coating grades

R = right hand version shown

L = left hand version

▲ In stock

Δ 2 weeks

Part number	r	f	a	d	b	l ₂	l ₅	t _{max}	D _{min}	HIS	Coating grades				
											EG35	IG35	TH35	TI25	TN35
R105.1833.005.2.6	0.05	3.3	5.7	4.7	7	15	30	0.5	6	105125	▲	▲	▲		▲
R105.1833.005.3.6	0.05	3.3	5.7	4.7	7	20	35	0.5	6	105125	Δ	▲	▲		▲
R105.1833.005.4.6	0.05	3.3	5.7	4.7	7	25	40	0.5	6	105125	Δ	▲	▲		▲
R105.1833.005.5.6	0.05	3.3	5.7	4.7	7	30	45	0.5	6	105125	Δ	▲			▲
R105.1833.2.6	0.2	3.3	5.7	4.7	7	15	30	0.5	6	105125	▲	▲	▲	▲	▲
R105.1833.3.6	0.2	3.3	5.7	4.7	7	20	35	0.5	6	105125	▲	▲	▲	▲	▲
R105.1833.4.6	0.2	3.3	5.7	4.7	7	25	40	0.5	6	105125	▲	▲	▲	▲	▲
R105.1833.5.6	0.2	3.3	5.7	4.7	7	30	45	0.5	6	105125	▲	▲	▲	▲	▲
R105.1840.005.3.7	0.05	4	6.4	5.2	7	20	35	0.5	6.8	105125	Δ	▲	▲		
R105.1840.005.4.7	0.05	4	6.4	5.2	7	25	40	0.5	6.8	105125	Δ	▲	▲	▲	
R105.1840.005.5.7	0.05	4	6.4	5.2	7	30	45	0.5	6.8	105125	Δ	▲	▲	▲	
R105.1840.3.7	0.2	4	6.4	5.2	7	20	35	0.5	6.8	105125	▲	▲	▲	▲	▲
R105.1840.4.7	0.2	4	6.4	5.2	7	25	40	0.5	6.8	105125	▲	▲	▲	▲	▲
R105.1840.5.7	0.2	4	6.4	5.2	7	30	45	0.5	6.8	105125	▲	▲	▲	▲	▲
L105.1833.005.2.6	0.05	3.3	5.7	4.7	7	15	30	0.5	6	105125	Δ				
L105.1833.005.3.6	0.05	3.3	5.7	4.7	7	20	35	0.5	6	105125	Δ				
L105.1833.005.4.6	0.05	3.3	5.7	4.7	7	25	40	0.5	6	105125	Δ				
L105.1833.005.5.6	0.05	3.3	5.7	4.7	7	30	45	0.5	6	105125	Δ				
L105.1833.2.6	0.2	3.3	5.7	4.7	7	15	30	0.5	6	105125	▲	▲	▲	▲	▲
L105.1833.3.6	0.2	3.3	5.7	4.7	7	20	35	0.5	6	105125	▲		▲	▲	▲
L105.1833.4.6	0.2	3.3	5.7	4.7	7	25	40	0.5	6	105125	▲		▲	▲	▲
L105.1833.5.6	0.2	3.3	5.7	4.7	7	30	45	0.5	6	105125	▲		▲	▲	▲
L105.1840.005.3.7	0.05	4	6.4	5.2	7	20	35	0.5	6.8	105125	Δ				
L105.1840.005.4.7	0.05	4	6.4	5.2	7	25	40	0.5	6.8	105125	Δ				
L105.1840.005.5.7	0.05	4	6.4	5.2	7	30	45	0.5	6.8	105125	Δ				
L105.1840.3.7	0.2	4	6.4	5.2	7	20	35	0.5	6.8	105125	▲		▲	▲	▲
L105.1840.4.7	0.2	4	6.4	5.2	7	25	40	0.5	6.8	105125	▲		▲	▲	▲
L105.1840.5.7	0.2	4	6.4	5.2	7	30	45	0.5	6.8	105125	▲		▲	▲	▲

Dimensions in mm

P	●	●	●	●	●
M	●	●	●	●	-
K	●	●	●	-	●
N	○	○	-	●	○
S	-	○	-	-	-
H	-	-	-	-	-

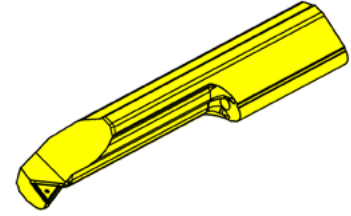
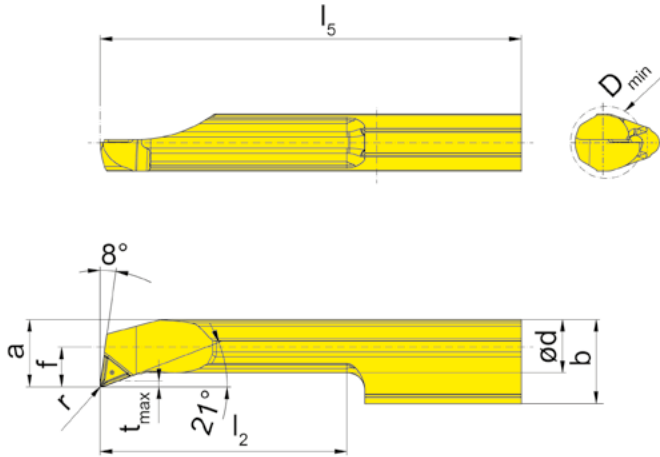
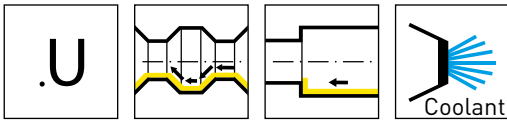

Coating grades

R = right hand version shown

▲ In stock

△ 2 weeks

Part number	r	f	a	d	b	l ₂	l ₅	t _{max}	D _{min}	HIS	IG35	TH35
RS105.1833.2.4.U20	0.2	3.3	3.7	2.5	7	15	30	0.5	4	105125	▲	▲
RS105.1833.3.4.U20	0.2	3.3	3.7	2.5	7	20	35	0.5	4	105125	▲	▲
RS105.1833.2.5.U20	0.2	3.3	4.7	3.5	7	15	30	0.5	5	105125	▲	▲
RS105.1833.3.5.U20	0.2	3.3	4.7	3.5	7	20	35	0.5	5	105125	▲	▲
RS105.1833.4.5.U20	0.2	3.3	4.7	3.5	7	25	40	0.5	5	105125	▲	▲
RS105.1833.2.6.U20	0.2	3.3	5.6	4.4	7	15	30	0.5	6	105125	▲	▲
RS105.1833.3.6.U20	0.2	3.3	5.6	4.4	7	20	35	0.5	6	105125	▲	▲
RS105.1833.4.6.U20	0.2	3.3	5.6	4.4	7	25	40	0.5	6	105125	▲	▲

Dimensions in mm

P	●	●
M	●	●
K	●	●
N	○	-
S	○	-
H	-	-

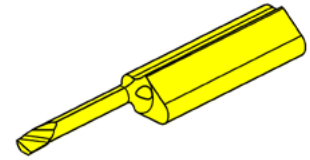
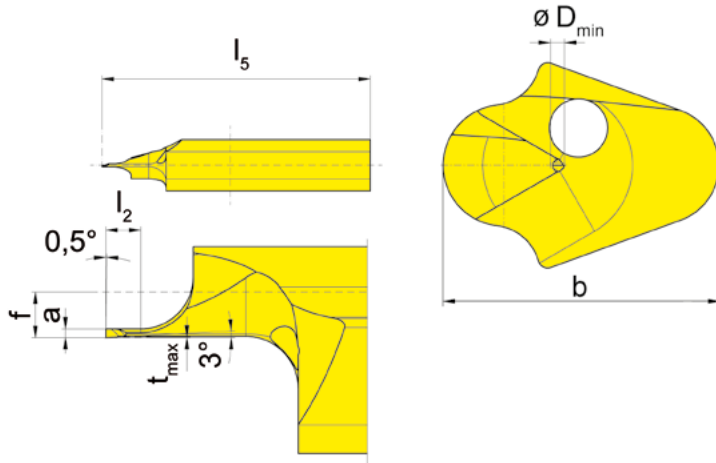
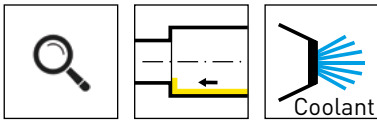

Coating grades

R = right hand version shown

▲ In stock

Δ 2 weeks

Part number	f	a	b	l_2	l_5	t_{max}	D_{min}	HIS	ES15
R105.9013.000.0.02	1.3	0.17	5.9	1	23	0.015	0.2	105123	▲
R105.9013.000.0.03	1.3	0.25	5.9	1	23	0.015	0.3	105123	▲
R105.9013.000.0.05	1.3	0.4	5.9	2	23	0.02	0.5	105123	▲
R105.9013.000.0.07	1.3	0.6	5.9	2	23	0.02	0.7	105123	▲

This insert is intended for low depths of cut where a high surface finish is required

This insert does not have a corner radius

Dimensions in mm

P	●
M	●
K	-
N	●
S	o
H	-

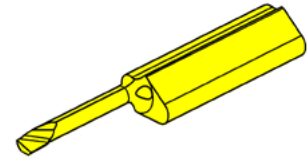
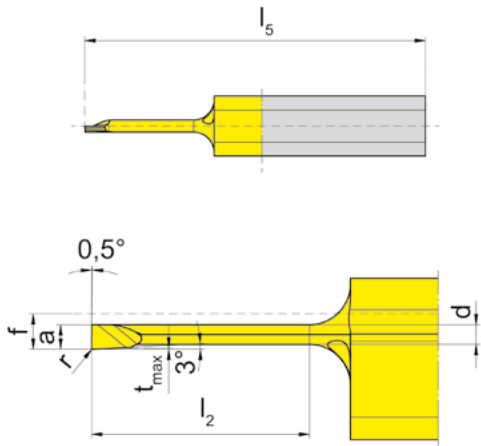
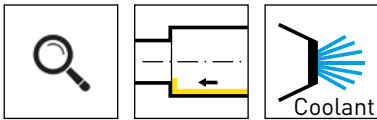

Coating grades

R = right hand version shown

▲ In stock

Δ 2 weeks

Part number	r	f	a	d	b	l_2	l_5	t_{max}	D_{min}	HIS	ES15
R105.9013.000.0.1	-	1.3	0.9	0.72	5.9	4	25	0.05	1	105123	▲
R105.9013.000.2.1	-	1.3	0.9	0.72	5.9	8	25	0.05	1	105123	▲
R105.9013.003.0.1	0.03	1.3	0.9	0.72	5.9	4	25	0.05	1	105123	▲
R105.9013.003.2.1	0.03	1.3	0.9	0.72	5.9	8	25	0.05	1	105123	Δ
R105.9013.000.0.15	-	1.3	1.4	1.15	5.9	6	25	0.1	1.5	105123	▲
R105.9013.000.1.15	-	1.3	1.4	1.15	5.9	9	25	0.1	1.5	105123	▲
R105.9013.003.0.15	0.03	1.3	1.4	1.15	5.9	6	25	0.1	1.5	105123	▲
R105.9013.003.1.15	0.03	1.3	1.4	1.15	5.9	9	25	0.1	1.5	105123	▲

This insert is intended for low depths of cut where a high surface finish is required

Dimensions in mm

P	●
M	●
K	-
N	●
S	○
H	-

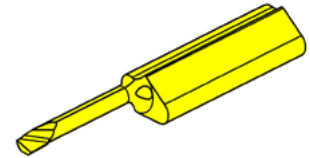
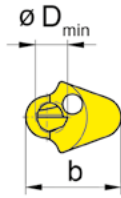
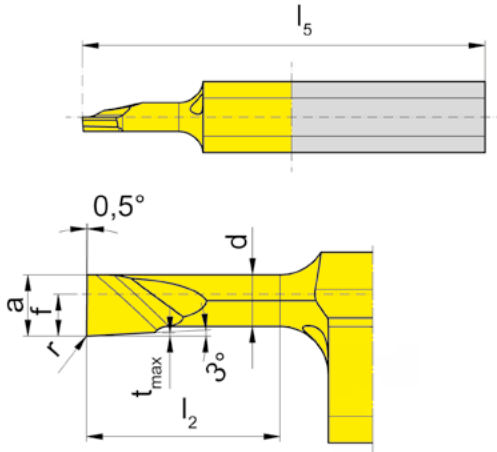
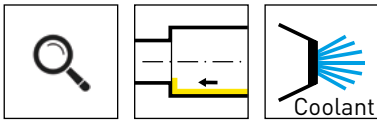

Coating grades

R = right hand version shown

▲ In stock

Δ 2 weeks

Part number	r	f	a	d	b	l_2	l_5	t_{max}	D_{min}	HIS	ES15
R105.9013.000.0.2	-	1.3	1.9	1.6	5.9	6	25	0.1	2	105123	▲
R105.9013.000.2.2	-	1.3	1.9	1.6	5.9	12	30	0.1	2	105123	▲
R105.9013.003.0.2	0.03	1.3	1.9	1.6	5.9	6	25	0.1	2	105123	▲
R105.9013.003.2.2	0.03	1.3	1.9	1.6	5.9	12	30	0.1	2	105123	▲
R105.9013.000.0.25	-	1.3	2.3	2	5.9	6	25	0.1	2.5	105123	▲
R105.9013.000.2.25	-	1.3	2.3	2	5.9	12	30	0.1	2.5	105123	▲
R105.9013.000.3.25	-	1.3	2.3	2	5.9	16	35	0.1	2.5	105123	▲
R105.9013.003.0.25	0.03	1.3	2.3	2	5.9	6	25	0.1	2.5	105123	▲
R105.9013.003.2.25	0.03	1.3	2.3	2	5.9	12	30	0.1	2.5	105123	▲
R105.9013.003.3.25	0.03	1.3	2.3	2	5.9	16	35	0.1	2.5	105123	▲

This insert is intended for low depths of cut where a high surface finish is required

Dimensions in mm

P	●
M	●
K	-
N	●
S	o
H	-

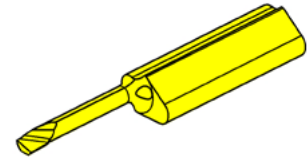
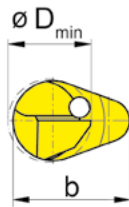
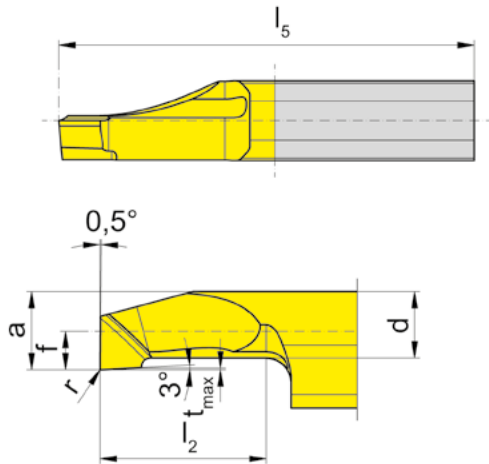
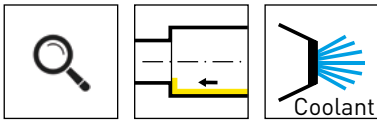

Coating grades

R = right hand version shown

▲ In stock

Δ 2 weeks

Part number	r	f	a	d	b	l_2	l_5	t_{max}	D_{min}	HIS	ES15
R105.9013.000.1.3	-	1.3	2.6	2.3	5.9	10	25	0.1	3	105123	▲
R105.9013.000.3.3	-	1.3	2.6	2.3	5.9	20	35	0.1	3	105123	▲
R105.9013.003.1.3	0.03	1.3	2.6	2.3	5.9	10	25	0.1	3	105123	▲
R105.9013.003.3.3	0.03	1.3	2.6	2.3	5.9	20	35	0.1	3	105123	▲
R105.9019.000.1.4	-	1.9	3.7	3.2	6.4	10	25	0.1	4	105124	Δ
R105.9019.000.3.4	-	1.9	3.7	3.2	6.4	20	35	0.1	4	105124	Δ
R105.9019.003.1.4	0.03	1.9	3.7	3.2	6.4	10	25	0.1	4	105124	Δ
R105.9019.003.3.4	0.03	1.9	3.7	3.2	6.4	20	35	0.1	4	105124	Δ

This insert is intended for low depths of cut where a high surface finish is required

Dimensions in mm

P	●
M	●
K	-
N	●
S	○
H	-

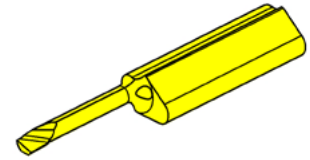
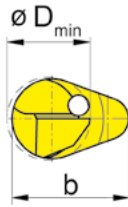
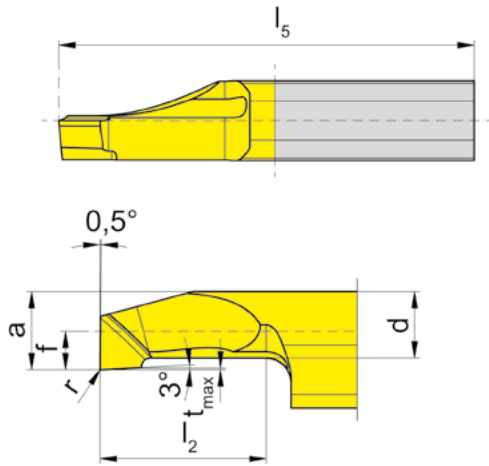
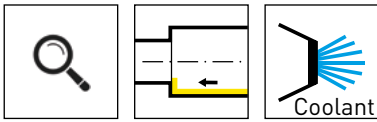

Coating grades

R = right hand version shown

▲ In stock

Δ 2 weeks

Part number	r	f	a	d	b	l_2	l_5	t_{max}	D_{min}	HIS	ES15
R105.9023.000.1.5	-	2.3	4.7	4	7	10	25	0.1	5	105125	▲
R105.9023.000.3.5	-	2.3	4.7	4	7	20	35	0.1	5	105125	▲
R105.9023.000.5.5	-	2.3	4.7	4	7	30	45	0.1	5	105125	▲
R105.9023.003.1.5	0.03	2.3	4.7	4	7	10	25	0.1	5	105125	▲
R105.9023.003.3.5	0.03	2.3	4.7	4	7	20	35	0.1	5	105125	▲
R105.9023.003.5.5	0.03	2.3	4.7	4	7	30	45	0.1	5	105125	▲

This insert is intended for low depths of cut where a high surface finish is required

Dimensions in mm

P	●
M	●
K	-
N	●
S	o
H	-

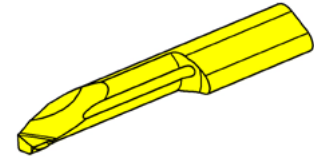
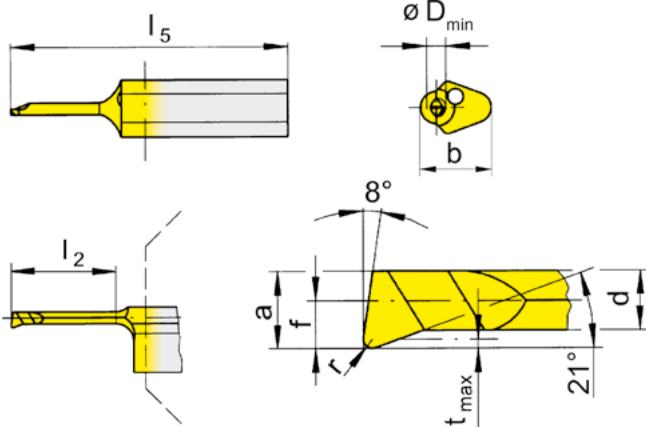
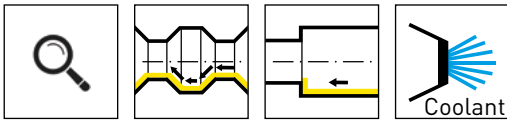

Coating grades

R = right hand version shown

L = left hand version

▲ In stock

Δ 2 weeks

Part number	r	f	a	d	b	l_2	l_5	t_{max}	D_{min}	HIS	ES15
R105.2108.003.0.1	0.03	0.5	0.9	0.65	5.9	4	25	0.1	1	105123	▲
R105.2108.003.1.1	0.03	0.5	0.9	0.65	5.9	6	25	0.1	1	105123	▲
R105.2108.003.2.1	0.03	0.5	0.9	0.65	5.9	8	25	0.1	1	105123	▲
R105.2108.008.0.1	0.08	0.5	0.9	0.65	5.9	4	25	0.1	1	105123	▲
R105.2108.008.1.1	0.08	0.5	0.9	0.65	5.9	6	25	0.1	1	105123	▲
R105.2108.008.2.1	0.08	0.5	0.9	0.65	5.9	8	25	0.1	1	105123	▲
R105.2108.003.0.15	0.03	1.3	1.4	1.1	5.9	6	25	0.15	1.5	105123	▲
R105.2108.003.1.15	0.03	1.3	1.4	1.1	5.9	9	25	0.15	1.5	105123	▲
R105.2108.003.2.15	0.03	1.3	1.4	1.1	5.9	12	30	0.15	1.5	105123	▲
R105.2108.008.0.15	0.08	1.3	1.4	1.1	5.9	6	25	0.15	1.5	105123	▲
R105.2108.008.1.15	0.08	1.3	1.4	1.1	5.9	9	25	0.15	1.5	105123	▲
R105.2108.008.2.15	0.08	1.3	1.4	1.1	5.9	12	30	0.15	1.5	105123	▲

This insert is intended for low depths of cut where a high surface finish is required

Dimensions in mm

P	●
M	●
K	-
N	●
S	o
H	-

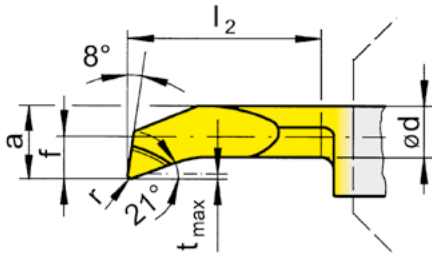
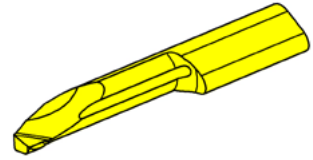
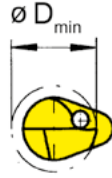
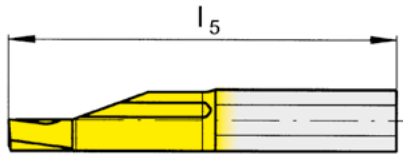
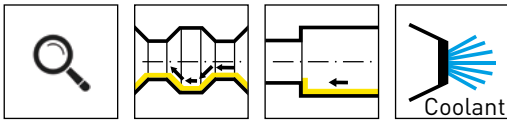

Coating grades

R = right hand version shown

▲ In stock

Δ 2 weeks

Part number	r	f	a	d	b	l_2	l_5	t_{max}	D_{min}	HIS	ES15
R105.2108.003.0.2	0.03	1	1.9	1.6	5.9	6	25	0.15	2	105123	▲
R105.2108.003.1.2	0.03	1	1.9	1.6	5.9	9	25	0.15	2	105123	▲
R105.2108.003.2.2	0.03	1	1.9	1.6	5.9	12	30	0.15	2	105123	▲
R105.2108.008.0.2	0.08	1	1.9	1.6	5.9	6	25	0.15	2	105123	▲
R105.2108.008.1.2	0.08	1	1.9	1.6	5.9	9	25	0.15	2	105123	▲
R105.2108.008.2.2	0.08	1	1.9	1.6	5.9	12	30	0.15	2	105123	▲
R105.2108.003.1.3	0.03	1.3	2.6	2.3	5.9	10	25	0.15	3	105123	▲
R105.2108.003.2.3	0.03	1.3	2.6	2.3	5.9	15	30	0.15	3	105123	▲
R105.2108.003.3.3	0.03	1.3	2.6	2.3	5.9	20	35	0.15	3	105123	▲
R105.2108.008.1.3	0.08	1.3	2.6	2.3	5.9	10	25	0.15	3	105123	▲
R105.2108.008.2.3	0.08	1.3	2.6	2.3	5.9	15	30	0.15	3	105123	▲
R105.2108.008.3.3	0.08	1.3	2.6	2.3	5.9	20	35	0.15	3	105123	▲

This insert is intended for low depths of cut where a high surface finish is required

Dimensions in mm

P	●
M	●
K	-
N	●
S	o
H	-

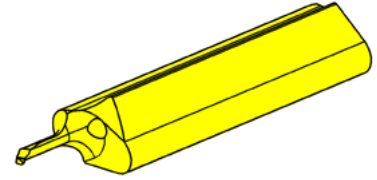
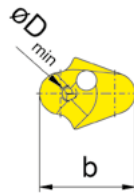
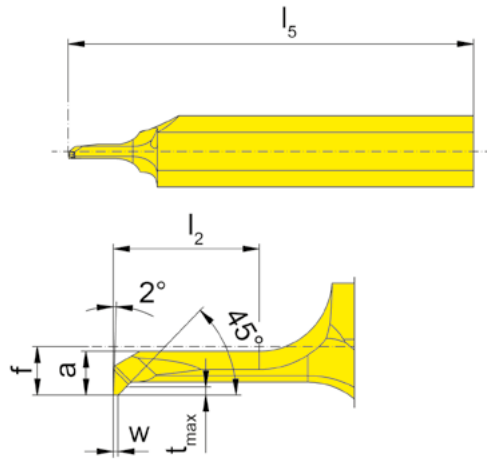
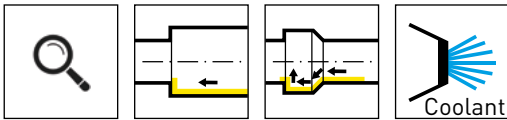

Coating grades

R = right hand version shown

▲ In stock

Δ 2 weeks

Part number	w	f	a	b	l_2	l_5	t_{max}	D_{min}	HIS	ES15
R105.4502.003.0.03	0.03	1	0.25	5.9	0.6	25	0.05	0.3	105123	▲
R105.4502.003.0.04	0.03	1	0.33	5.9	0.8	25	0.07	0.4	105123	▲
R105.4502.003.0.05	0.03	1	0.45	5.9	1.2	25	0.08	0.5	105123	▲
R105.4502.003.0.06	0.03	1	0.52	5.9	1.2	25	0.1	0.6	105123	▲
R105.4502.003.0.07	0.03	1	0.6	5.9	1.2	25	0.12	0.7	105123	▲
R105.4502.005.0.08	0.05	1	0.7	5.9	1.8	25	0.15	0.8	105123	▲
R105.4502.005.0.09	0.05	1	0.8	5.9	1.8	25	0.15	0.9	105123	▲
R105.4502.010.0.10	0.1	1	0.9	5.9	3	25	0.17	1	105123	▲
R105.4502.010.0.12	0.1	1	1	5.9	3.6	25	0.2	1.2	105123	▲
R105.4502.010.0.15	0.1	1.3	1.4	5.9	4.5	25	0.25	1.5	105123	▲
R105.4502.020.0.20	0.2	1.3	1.8	5.9	6	25	0.35	2	105123	▲
R105.4502.020.0.25	0.2	1.3	2.3	5.9	7.5	25	0.45	2.5	105123	▲
R105.4502.030.0.30	0.3	1.3	2.6	5.9	9	25	0.5	3	105123	▲
R105.4502.030.0.35	0.3	1.9	3.2	6.4	10	25	0.6	3.5	105124	▲

This insert is intended for low depths of cut where a high surface finish is required

This insert does not have a corner radius

Dimensions in mm

P	●
M	●
K	-
N	●
S	o
H	-

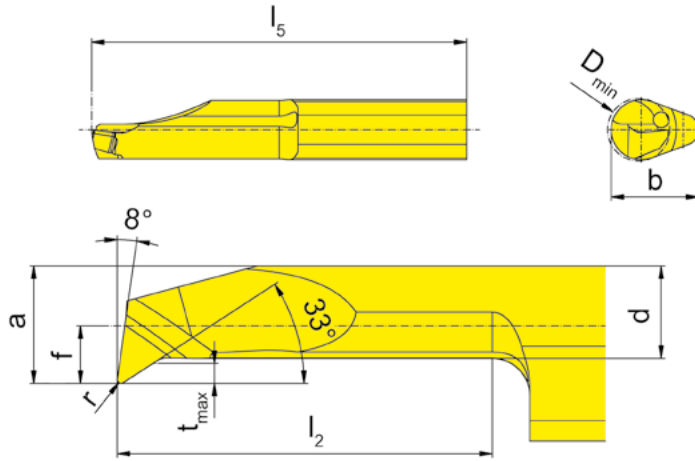
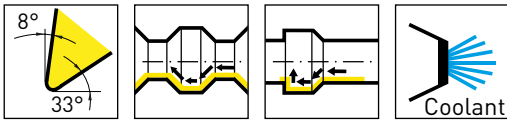

Coating grades

R = right hand version shown

L = left hand version

▲ In stock

△ 2 weeks

Part number	r	f	a	d	b	l ₂	l ₅	t _{max}	D _{min}	HIS	EG35	IG35
R105.3315.005.1.2	0.05	1.5	1.9	1.45	5.9	9	25	0.3	2	105123	▲	▲
R105.3315.005.2.2	0.05	1.5	1.9	1.45	5.9	12	30	0.3	2	105123	▲	▲
R105.3313.005.1.3	0.05	1.3	2.6	2	5.9	10	25	0.4	3	105123	▲	▲
R105.3313.005.2.3	0.05	1.3	2.6	2	5.9	15	30	0.4	3	105123	▲	▲
R105.3319.1.4	0.15	1.9	3.7	2.9	6.4	10	25	0.6	4	105124	▲	▲
R105.3319.3.4	0.15	1.9	3.7	2.9	6.4	20	35	0.6	4	105124	▲	▲
R105.3323.2.5	0.15	2.3	4.7	3.7	7	15	30	0.8	5	105125	▲	▲
R105.3323.4.5	0.15	2.3	4.7	3.7	7	25	40	0.8	5	105125	▲	▲
R105.3333.3.6	0.15	3.3	5.7	3.7	7	20	35	1.8	6	105125	▲	▲
R105.3333.5.6	0.15	3.3	5.7	3.7	7	30	45	1.8	6	105125	▲	▲
L105.3319.1.4	0.15	1.9	3.7	2.9	6.4	10	25	0.6	4	105124		
L105.3319.3.4	0.15	1.9	3.7	2.9	6.4	20	35	0.6	4	105124		
L105.3323.2.5	0.15	2.3	4.7	3.7	7	15	30	0.8	5	105125		
L105.3323.4.5	0.15	2.3	4.7	3.7	7	25	40	0.8	5	105125		
L105.3333.3.6	0.15	3.3	5.7	3.7	7	20	35	1.8	6	105125		
L105.3333.5.6	0.15	3.3	5.7	3.7	7	30	45	1.8	6	105125		

Dimensions in mm

P	●	●
M	●	●
K	●	●
N	o	o
S	-	o
H	-	-

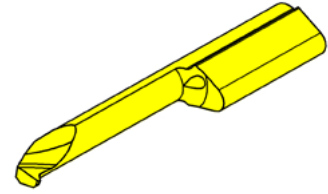
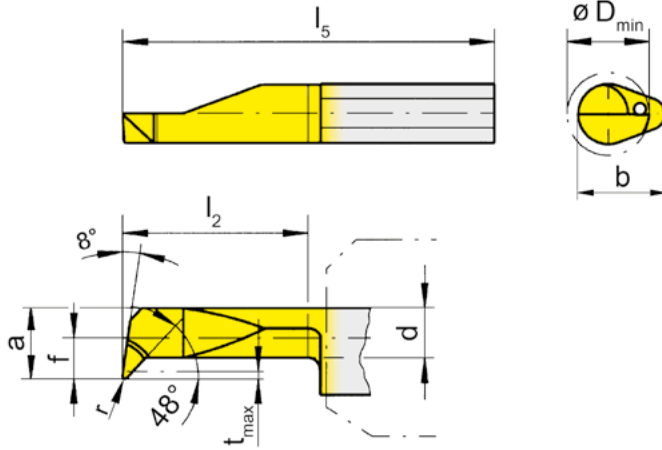
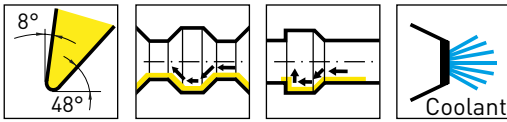

Coating grades

R = right hand version shown

L = left hand version

▲ In stock

△ 2 weeks

Part number	r	f	a	d	b	l ₂	l ₅	t _{max}	D _{min}	HIS	EG35	ES15	IG35	TF45	TH35	TI25	TN35
R105.4715.005.1.2	0.05	1.5	1.9	1.45	5.9	9	25	0.3	2	105123	▲	▲	▲				
R105.4715.005.2.2	0.05	1.5	1.9	1.45	5.9	12	30	0.3	2	105123	▲	▲	▲				
R105.4713.005.1.3	0.05	1.3	2.6	2	5.9	10	25	0.4	3	105123	▲	▲	▲				
R105.4713.005.2.3	0.05	1.3	2.6	2	5.9	15	30	0.4	3	105123	▲	▲	▲				
R105.4719.1.4	0.15	1.9	3.7	2.9	6.4	10	25	0.6	4	105124	▲	▲	▲		▲		
R105.4719.3.4	0.15	1.9	3.7	2.9	6.4	20	35	0.6	4	105124	▲	▲	▲	▲	▲	▲	▲
R105.4723.2.5	0.15	2.3	4.7	3.7	7	15	30	0.8	5	105125	▲	▲	▲		▲		
R105.4723.4.5	0.15	2.3	4.7	3.7	7	25	40	0.8	5	105125	▲	▲	▲		▲	▲	▲
R105.4733.3.6	0.15	3.3	5.7	3.7	7	20	35	1.8	6	105125	▲	▲	▲		▲		
R105.4733.5.6	0.15	3.3	5.7	3.7	7	30	45	1.8	6	105125	▲	▲	▲		▲	△	▲
L105.4719.1.4	0.15	1.9	3.7	2.9	6.4	10	25	0.6	4	105124	▲	▲	▲		▲		
L105.4719.3.4	0.15	1.9	3.7	2.9	6.4	20	35	0.6	4	105124	▲	▲	▲		▲	▲	▲
L105.4723.2.5	0.15	2.3	4.7	3.7	7	15	30	0.8	5	105125	△	▲	▲		▲		
L105.4723.4.5	0.15	2.3	4.7	3.7	7	25	40	0.8	5	105125	▲	▲	▲		▲	▲	▲
L105.4733.3.6	0.15	3.3	5.7	3.7	7	20	35	1.8	6	105125	△	▲	▲		▲		
L105.4733.5.6	0.15	3.3	5.7	3.7	7	30	45	1.8	6	105125	▲	▲	▲		▲	△	▲

Dimensions in mm

P	●	●	●	-	●	●	●
M	●	●	●	-	●	●	-
K	●	-	●	-	●	-	●
N	○	●	○	-	-	●	○
S	-	○	○	-	-	-	-
H	-	-	-	-	-	-	-

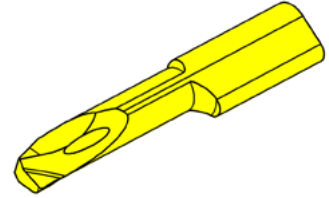
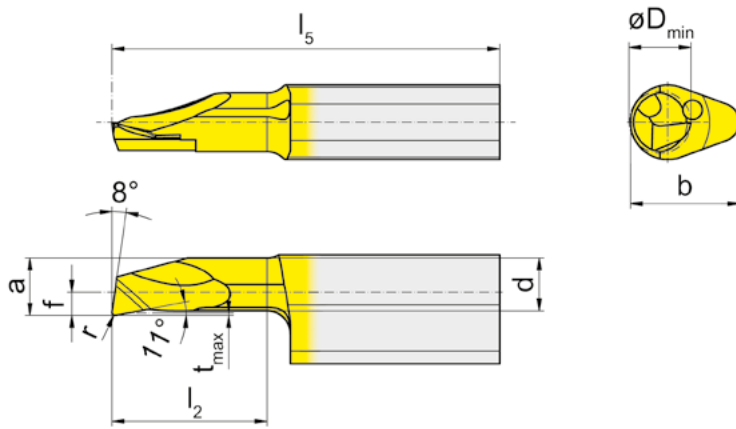
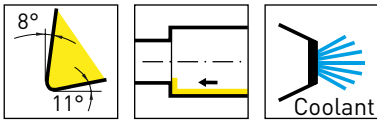

Coating grades

R = right hand version shown

L = left hand version

▲ In stock

△ 2 weeks

Part number	r	f	a	d	b	l_2	l_5	t_{max}	D_{min}	HIS	EG35	IG35	TH35
R105.1019.005.1.4	0.05	1.5	3.7	3.4	7	10	25	0.15	4	105125	△	▲	▲
R105.1019.005.2.4	0.05	1.5	3.7	3.4	7	15	30	0.15	4	105125	△	▲	▲
R105.1019.005.3.4	0.05	1.5	3.7	3.4	7	20	35	0.15	4	105125	△	▲	▲
R105.1019.005.4.4	0.05	1.5	3.7	3.4	7	25	40	0.15	4	105125	△	▲	▲
R105.1019.1.4	0.2	1.5	3.7	3.4	7	10	25	0.15	4	105125	▲	▲	▲
R105.1019.2.4	0.2	1.5	3.7	3.4	7	15	30	0.15	4	105125	▲	▲	▲
R105.1019.3.4	0.2	1.5	3.7	3.4	7	20	35	0.15	4	105125	▲	▲	▲
R105.1019.4.4	0.2	1.5	3.7	3.4	7	25	40	0.15	4	105125	▲	▲	▲
L105.1019.005.1.4	0.05	1.5	3.7	3.4	7	10	25	0.15	4	105125	△		▲
L105.1019.005.2.4	0.05	1.5	3.7	3.4	7	15	30	0.15	4	105125	△		▲
L105.1019.005.3.4	0.05	1.5	3.7	3.4	7	20	35	0.15	4	105125	△		▲
L105.1019.005.4.4	0.05	1.5	3.7	3.4	7	25	40	0.15	4	105125	△		▲
L105.1019.1.4	0.2	1.5	3.7	3.4	7	10	25	0.15	4	105125	△		▲
L105.1019.2.4	0.2	1.5	3.7	3.4	7	15	30	0.15	4	105125	△		▲
L105.1019.3.4	0.2	1.5	3.7	3.4	7	20	35	0.15	4	105125	△		▲
L105.1019.4.4	0.2	1.5	3.7	3.4	7	25	40	0.15	4	105125	△		▲

These inserts feature a reinforced design, optimized for rigidity in straight boring applications

Dimensions in mm

P	●	●	●
M	●	●	●
K	●	●	●
N	o	o	-
S	-	o	-
H	-	-	-

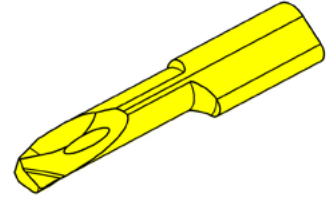
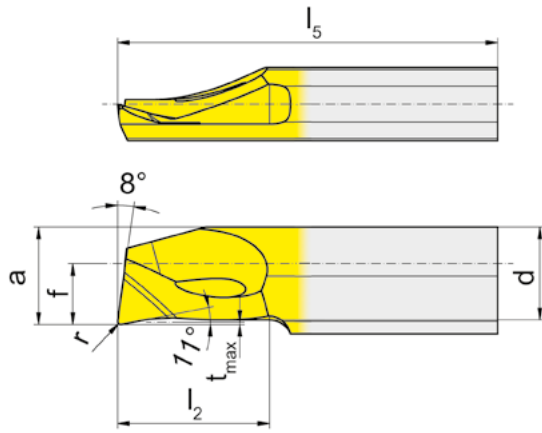
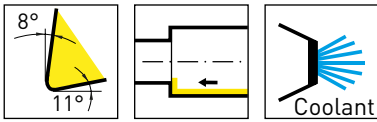

Coating grades

R = right hand version shown

L = left hand version

▲ In stock

△ 2 weeks

Part number	r	f	a	d	b	l ₂	l ₅	t _{max}	D _{min}	HIS	EG35	IG35	TH35
R105.1023.005.1.5	0.05	2.8	4.7	4.4	7	10	25	0.15	5	105125	▲	▲	▲
R105.1023.005.2.5	0.05	2.8	4.7	4.4	7	15	30	0.15	5	105125	△	▲	▲
R105.1023.005.3.5	0.05	2.8	4.7	4.4	7	20	35	0.15	5	105125	△	▲	▲
R105.1023.005.4.5	0.05	2.8	4.7	4.4	7	25	40	0.15	5	105125	△	▲	▲
R105.1023.005.5.5	0.05	2.8	4.7	4.4	7	30	45	0.15	5	105125	△	▲	▲
R105.1023.005.6.5	0.05	2.8	4.7	4.4	7	35	50	0.15	5	105125	△	▲	▲
R105.1023.1.5	0.2	2.8	4.7	4.4	7	10	25	0.15	5	105125	△	▲	▲
R105.1023.2.5	0.2	2.8	4.7	4.4	7	15	30	0.15	5	105125	△	▲	▲
R105.1023.3.5	0.2	2.8	4.7	4.4	7	20	35	0.15	5	105125	△	▲	▲
R105.1023.4.5	0.2	2.8	4.7	4.4	7	25	40	0.15	5	105125	△	▲	▲
R105.1023.5.5	0.2	2.8	4.7	4.4	7	30	45	0.15	5	105125	△	▲	▲
R105.1023.6.5	0.2	2.8	4.7	4.4	7	35	50	0.15	5	105125	△	▲	▲
L105.1023.005.1.5	0.05	2.8	4.7	4.4	7	10	25	0.15	5	105125	△		▲
L105.1023.005.2.5	0.05	2.8	4.7	4.4	7	15	30	0.15	5	105125	△		▲
L105.1023.005.3.5	0.05	2.8	4.7	4.4	7	20	35	0.15	5	105125	△		▲
L105.1023.005.4.5	0.05	2.8	4.7	4.4	7	25	40	0.15	5	105125	△		▲
L105.1023.005.5.5	0.05	2.8	4.7	4.4	7	30	45	0.15	5	105125	△		▲
L105.1023.005.6.5	0.05	2.8	4.7	4.4	7	35	50	0.15	5	105125	△		▲
L105.1023.1.5	0.2	2.8	4.7	4.4	7	10	25	0.15	5	105125	△		▲
L105.1023.2.5	0.2	2.8	4.7	4.4	7	15	30	0.15	5	105125			▲
L105.1023.3.5	0.2	2.8	4.7	4.4	7	20	35	0.15	5	105125	△		▲
L105.1023.4.5	0.2	2.8	4.7	4.4	7	25	40	0.15	5	105125	△		▲
L105.1023.5.5	0.2	2.8	4.7	4.4	7	30	45	0.15	5	105125	△		▲
L105.1023.6.5	0.2	2.8	4.7	4.4	7	35	50	0.15	5	105125	△		▲

These inserts feature a reinforced design, optimized for rigidity in straight boring applications

Dimensions in mm

P	●	●	●
M	●	●	●
K	●	●	●
N	○	○	-
S	-	○	-
H	-	-	-

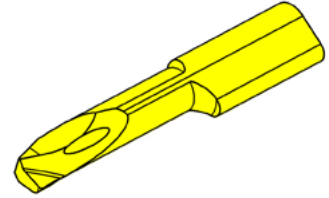
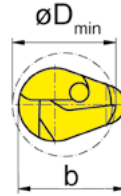
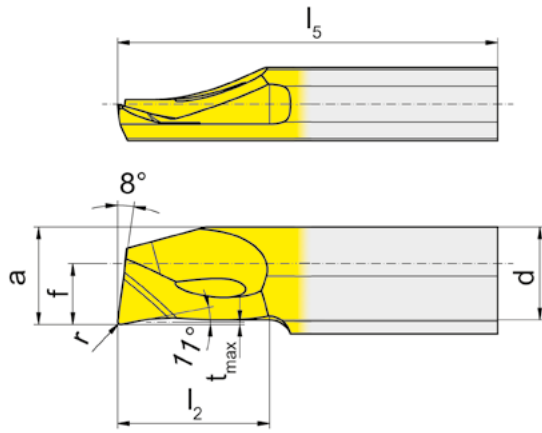
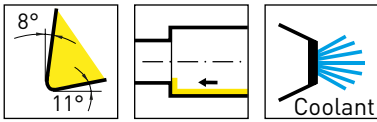

Coating grades

R = right hand version shown

L = left hand version

▲ In stock

△ 2 weeks

Part number	r	f	a	d	b	l_2	l_5	t_{max}	D_{min}	HIS	EG35	IG35	TH35
R105.1033.005.1.6	0.05	3.3	5.7	5.4	7	10	25	0.15	6	105125	△	▲	▲
R105.1033.005.2.6	0.05	3.3	5.7	5.4	7	15	30	0.15	6	105125	△	▲	▲
R105.1033.005.3.6	0.05	3.3	5.7	5.4	7	20	35	0.15	6	105125	△	▲	▲
R105.1033.005.4.6	0.05	3.3	5.7	5.4	7	25	40	0.15	6	105125	△	▲	▲
R105.1033.005.5.6	0.05	3.3	5.7	5.4	7	30	45	0.15	6	105125	△	▲	▲
R105.1033.005.6.6	0.05	3.3	5.7	5.4	7	35	50	0.15	6	105125	△	▲	▲
R105.1033.1.6	0.2	3.3	5.7	5.4	7	10	25	0.15	6	105125	▲	▲	▲
R105.1033.2.6	0.2	3.3	5.7	5.4	7	15	30	0.15	6	105125	▲	▲	▲
R105.1033.3.6	0.2	3.3	5.7	5.4	7	20	35	0.15	6	105125	▲	▲	▲
R105.1033.4.6	0.2	3.3	5.7	5.4	7	25	40	0.15	6	105125	△	▲	▲
R105.1033.5.6	0.2	3.3	5.7	5.4	7	30	45	0.15	6	105125	▲	▲	▲
R105.1033.6.6	0.2	3.3	5.7	5.4	7	35	50	0.15	6	105125	▲	▲	▲
L105.1033.005.1.6	0.05	3.3	5.7	5.4	7	10	25	0.15	6	105125	△		▲
L105.1033.005.2.6	0.05	3.3	5.7	5.4	7	15	30	0.15	6	105125	△		▲
L105.1033.005.3.6	0.05	3.3	5.7	5.4	7	20	35	0.15	6	105125	△		▲
L105.1033.005.4.6	0.05	3.3	5.7	5.4	7	25	40	0.15	6	105125	△		▲
L105.1033.005.5.6	0.05	3.3	5.7	5.4	7	30	45	0.15	6	105125	△		▲
L105.1033.005.6.6	0.05	3.3	5.7	5.4	7	35	50	0.15	6	105125	△		▲
L105.1033.1.6	0.2	3.3	5.7	5.4	7	10	25	0.15	6	105125			▲
L105.1033.2.6	0.2	3.3	5.7	5.4	7	15	30	0.15	6	105125	△		▲
L105.1033.3.6	0.2	3.3	5.7	5.4	7	20	35	0.15	6	105125	△		▲
L105.1033.4.6	0.2	3.3	5.7	5.4	7	25	40	0.15	6	105125	△		▲
L105.1033.5.6	0.2	3.3	5.7	5.4	7	30	45	0.15	6	105125	△		▲
L105.1033.6.6	0.2	3.3	5.7	5.4	7	35	50	0.15	6	105125	△		▲

These inserts feature a reinforced design, optimized for rigidity in straight boring applications

Dimensions in mm

P	●	●	●
M	●	●	●
K	●	●	●
N	○	○	-
S	-	○	-
H	-	-	-

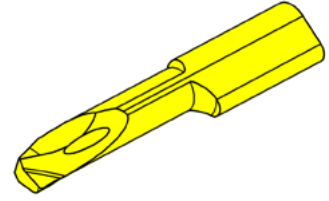
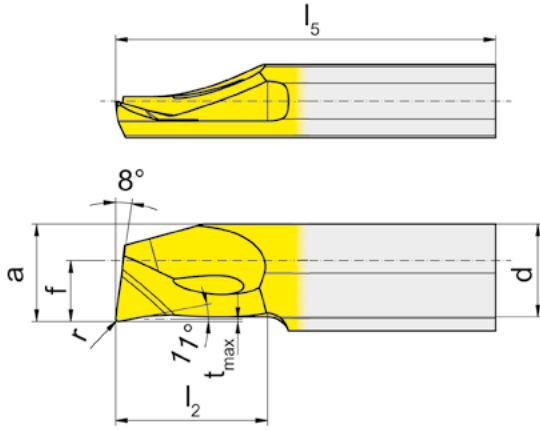
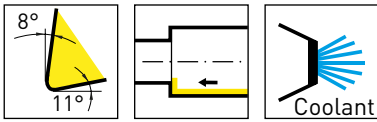

Coating grades

R = right hand version shown

L = left hand version

▲ In stock

Δ 2 weeks

Part number	r	f	a	d	b	l ₂	l ₅	t _{max}	D _{min}	HIS	EG35	IG35	TH35
R105.1040.1.7	0.2	4	6.4	6.1	7	10	25	0.15	6.8	105125	▲	▲	▲
R105.1040.2.7	0.2	4	6.4	6.1	7	15	30	0.15	6.8	105125	▲	▲	▲
R105.1040.3.7	0.2	4	6.4	6.1	7	20	35	0.15	6.8	105125	▲	▲	▲
R105.1040.4.7	0.2	4	6.4	6.1	7	25	40	0.15	6.8	105125	▲	▲	▲
R105.1040.5.7	0.2	4	6.4	6.1	7	30	45	0.15	6.8	105125	▲	▲	▲
R105.1040.6.7	0.2	4	6.4	6.1	7	35	50	0.15	6.8	105125	▲	▲	▲
L105.1040.1.7	0.2	4	6.4	6.1	7	10	25	0.15	6.8	105125	Δ		▲
L105.1040.2.7	0.2	4	6.4	6.1	7	15	30	0.15	6.8	105125	Δ		▲
L105.1040.3.7	0.2	4	6.4	6.1	7	20	35	0.15	6.8	105125	Δ		▲
L105.1040.4.7	0.2	4	6.4	6.1	7	25	40	0.15	6.8	105125	Δ		▲
L105.1040.5.7	0.2	4	6.4	6.1	7	30	45	0.15	6.8	105125	Δ		▲
L105.1040.6.7	0.2	4	6.4	6.1	7	35	50	0.15	6.8	105125	Δ		▲

These inserts feature a reinforced design, optimized for rigidity in straight boring applications

Dimensions in mm

P	●	●	●
M	●	●	●
K	●	●	●
N	○	○	-
S	-	○	-
H	-	-	-

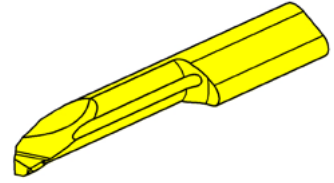
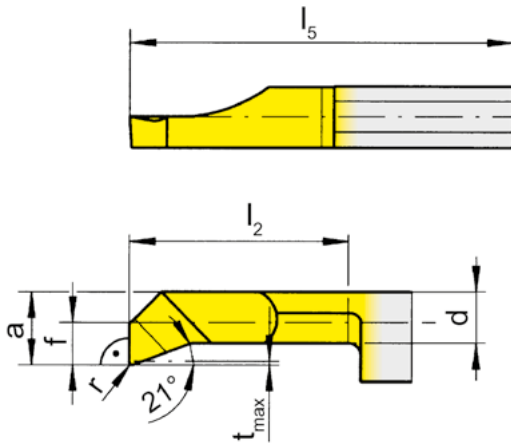
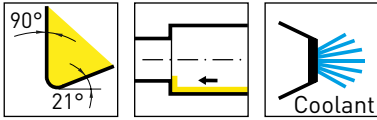

Coating grades

R = right hand version shown

L = left hand version

▲ In stock

Δ 2 weeks

Part number	r	f	a	d	b	l ₂	l ₅	t _{max}	D _{min}	HIS	Coating grades			
											EG35	IG35	TH35	TN35
R105.9013.01.1.3	0.1	1.3	2.6	2.3	5.9	10	25	0.15	3	105123	Δ	▲	▲	
R105.9013.01.2.3	0.1	1.3	2.6	2.3	5.9	15	30	0.15	3	105123	Δ	▲	▲	
R105.9013.01.3.3	0.1	1.3	2.6	2.3	5.9	20	35	0.15	3	105123	▲	▲		
R105.9013.1.3	0.2	1.3	2.6	2.3	5.9	10	25	0.15	3	105123	▲	▲		▲
R105.9013.2.3	0.2	1.3	2.6	2.3	5.9	15	30	0.15	3	105123	▲	▲		▲
R105.9019.01.1.4	0.1	1.9	3.7	2.9	6.4	10	25	0.3	4	105124	Δ	▲	▲	
R105.9019.01.2.4	0.1	1.9	3.7	2.9	6.4	15	30	0.3	4	105124	Δ	▲	▲	
R105.9019.01.3.4	0.1	1.9	3.7	2.9	6.4	20	35	0.3	4	105124	Δ	▲	▲	
R105.9019.1.4	0.2	1.9	3.7	2.9	6.4	10	25	0.3	4	105124	▲	▲		▲
R105.9019.2.4	0.2	1.9	3.7	2.9	6.4	15	30	0.3	4	105124	▲	▲		▲
L105.9013.01.1.3	0.1	1.3	2.6	2.3	5.9	10	25	0.15	3	105123	Δ		▲	
L105.9013.01.2.3	0.1	1.3	2.6	2.3	5.9	15	30	0.15	3	105123	Δ		Δ	
L105.9013.01.3.3	0.1	1.3	2.6	2.3	5.9	20	35	0.15	3	105123	Δ			
L105.9013.1.3	0.2	1.3	2.6	2.3	5.9	10	25	0.15	3	105123	▲			▲
L105.9013.2.3	0.2	1.3	2.6	2.3	5.9	15	30	0.15	3	105123	▲			▲
L105.9019.01.1.4	0.1	1.9	3.7	2.9	6.4	10	25	0.3	4	105124	Δ		Δ	
L105.9019.01.2.4	0.1	1.9	3.7	2.9	6.4	15	30	0.3	4	105124	Δ		Δ	
L105.9019.01.3.4	0.1	1.9	3.7	2.9	6.4	20	35	0.3	4	105124	Δ		Δ	
L105.9019.1.4	0.2	1.9	3.7	2.9	6.4	10	25	0.3	4	105124	▲			▲
L105.9019.2.4	0.2	1.9	3.7	2.9	6.4	15	30	0.3	4	105124	▲			▲

Dimensions in mm

	P	M	K	N	S	H
EG35	●	●	●	○	-	-
IG35	●	●	●	○	-	-
TH35	●	●	●	-	-	-
TN35	●	-	●	○	-	-

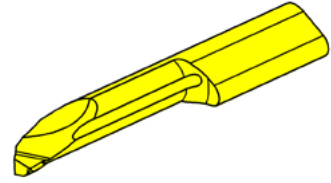
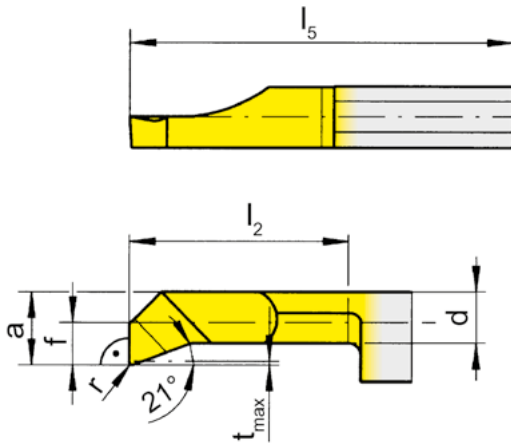
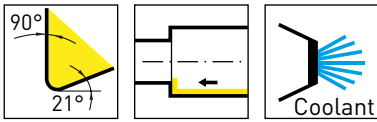

Coating grades

R = right hand version shown

L = left hand version

▲ In stock

△ 2 weeks

Part number	r	f	a	d	b	l ₂	l ₅	t _{max}	D _{min}	HIS	EG35	IG35	TH35	TN35
R105.9023.01.1.5	0.1	2.3	4.7	4	7	10	25	0.5	5	105125	△	▲	▲	
R105.9023.01.2.5	0.1	2.3	4.7	4	7	15	30	0.5	5	105125	▲	▲	▲	
R105.9023.01.3.5	0.1	2.3	4.7	4	7	20	35	0.5	5	105125	△	▲	▲	
R105.9023.01.4.5	0.1	2.3	4.7	4	7	25	40	0.5	5	105125	△	▲	▲	
R105.9023.1.5	0.2	2.3	4.7	4	7	10	25	0.5	5	105125	▲	▲	▲	▲
R105.9023.2.5	0.2	2.3	4.7	4	7	15	30	0.5	5	105125	▲	▲	▲	▲
R105.9023.3.5	0.2	2.3	4.7	4	7	20	35	0.5	5	105125	▲	▲		▲
R105.9033.1.6	0.2	3.3	5.7	4.7	7	10	25	0.5	6	105125	△	▲	▲	
R105.9033.2.6	0.2	3.3	5.7	4.7	7	15	30	0.5	6	105125	△	▲	▲	
R105.9033.3.6	0.2	3.3	5.7	4.7	7	20	35	0.5	6	105125	△	▲	▲	
R105.9033.4.6	0.2	3.3	5.7	4.7	7	25	40	0.5	6	105125	△	▲	▲	
R105.9033.5.6	0.2	3.3	5.7	4.7	7	30	45	0.5	6	105125	△	▲	▲	
L105.9023.01.1.5	0.1	2.3	4.7	4	7	10	25	0.5	5	105125	△		△	
L105.9023.01.2.5	0.1	2.3	4.7	4	7	15	30	0.5	5	105125	△		▲	
L105.9023.01.3.5	0.1	2.3	4.7	4	7	20	35	0.5	5	105125	△		▲	
L105.9023.01.4.5	0.1	2.3	4.7	4	7	25	40	0.5	5	105125	△			
L105.9023.1.5	0.2	2.3	4.7	4	7	10	25	0.5	5	105125	▲			▲
L105.9023.2.5	0.2	2.3	4.7	4	7	15	30	0.5	5	105125	▲			▲
L105.9023.3.5	0.2	2.3	4.7	4	7	20	35	0.5	5	105125				▲
L105.9033.1.6	0.2	3.3	5.7	4.7	7	10	25	0.5	6	105125	△			
L105.9033.2.6	0.2	3.3	5.7	4.7	7	15	30	0.5	6	105125	△		△	
L105.9033.3.6	0.2	3.3	5.7	4.7	7	20	35	0.5	6	105125	△		▲	
L105.9033.4.6	0.2	3.3	5.7	4.7	7	25	40	0.5	6	105125	△		△	
L105.9033.5.6	0.2	3.3	5.7	4.7	7	30	45	0.5	6	105125	△		▲	

Dimensions in mm

P	●	●	●	●
M	●	●	●	-
K	●	●	●	●
N	○	○	-	○
S	-	○	-	-
H	-	-	-	-

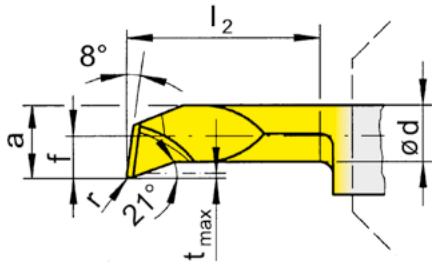
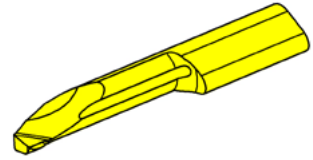
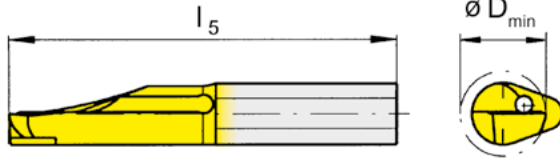
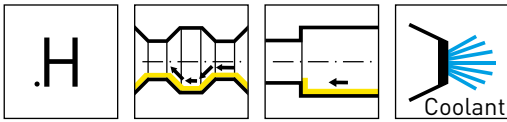

Coating grades

R = right hand version shown

L = left hand version

▲ In stock

Δ 2 weeks

Part number	r	f	a	d	b	l_2	l_5	t_{max}	D_{min}	HIS	EG35	IG35	TH35
R105.1819.1.H.4	0.2	1.9	3.7	2.9	7	10	25	0.3	4	105125	Δ		▲
R105.1819.2.H.4	0.2	1.9	3.7	2.9	7	15	30	0.3	4	105125	Δ		▲
R105.1819.3.H.4	0.2	1.9	3.7	2.9	7	20	35	0.3	4	105125	Δ		▲
R105.1823.1.H.5	0.2	2.3	4.7	4	7	10	25	0.5	5	105125	Δ	▲	▲
R105.1823.2.H.5	0.2	2.3	4.7	4	7	15	30	0.5	5	105125	Δ	▲	▲
R105.1823.3.H.5	0.2	2.3	4.7	4	7	20	35	0.5	5	105125	Δ		▲
R105.1823.4.H.5	0.2	2.3	4.7	4	7	25	40	0.5	5	105125	Δ		▲
R105.1823.5.H.5	0.2	2.3	4.7	4	7	30	45	0.5	5	105125	Δ		▲
L105.1819.1.H.4	0.2	1.9	3.7	2.9	7	10	25	0.3	4	105125	Δ		▲
L105.1819.2.H.4	0.2	1.9	3.7	2.9	7	15	30	0.3	4	105125	Δ		Δ
L105.1819.3.H.4	0.2	1.9	3.7	2.9	7	20	35	0.3	4	105125	Δ		▲
L105.1823.1.H.5	0.2	2.3	4.7	4	7	10	25	0.5	5	105125	Δ		▲
L105.1823.2.H.5	0.2	2.3	4.7	4	7	15	30	0.5	5	105125	Δ		Δ
L105.1823.3.H.5	0.2	2.3	4.7	4	7	20	35	0.5	5	105125	Δ		▲
L105.1823.4.H.5	0.2	2.3	4.7	4	7	25	40	0.5	5	105125	Δ		Δ
L105.1823.5.H.5	0.2	2.3	4.7	4	7	30	45	0.5	5	105125	Δ		Δ

Dimensions in mm

P	●	●	●
M	●	●	●
K	●	●	●
N	o	o	-
S	-	o	-
H	-	-	-

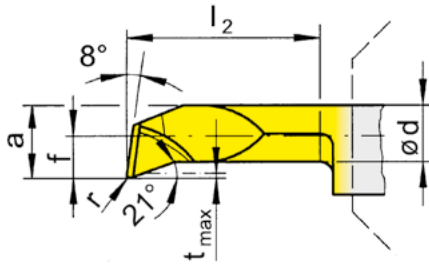
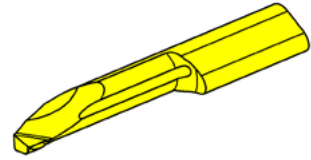
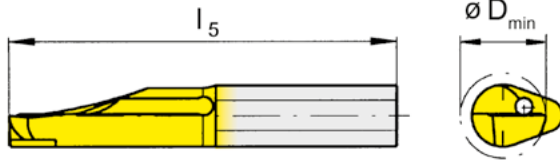
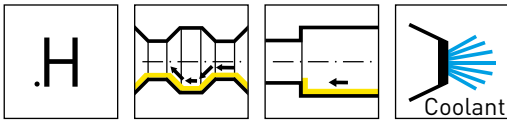

Coating grades

R = right hand version shown

L = left hand version

▲ In stock

Δ 2 weeks

Part number	r	f	a	d	b	l_2	l_5	t_{max}	D_{min}	HIS	EG35	IG35	TH35
R105.1833.2.H.6	0.2	3.3	5.7	4.7	7	15	30	0.5	6	105125	Δ		▲
R105.1833.3.H.6	0.2	3.3	5.7	4.7	7	20	35	0.5	6	105125	Δ		▲
R105.1833.4.H.6	0.2	3.3	5.7	4.7	7	25	40	0.5	6	105125	Δ		▲
R105.1833.5.H.6	0.2	3.3	5.7	4.7	7	30	45	0.5	6	105125	Δ	▲	▲
R105.1840.3.H.7	0.2	4	6.4	5.2	7	20	35	0.5	7	105125	▲		▲
R105.1840.4.H.7	0.2	4	6.4	5.2	7	25	40	0.5	7	105125	Δ		▲
R105.1840.5.H.7	0.2	4	6.4	5.2	7	30	45	0.5	7	105125	Δ	▲	▲
L105.1833.2.H.6	0.2	3.3	5.7	4.7	7	15	30	0.5	6	105125	Δ		Δ
L105.1833.3.H.6	0.2	3.3	5.7	4.7	7	20	35	0.5	6	105125	Δ		Δ
L105.1833.4.H.6	0.2	3.3	5.7	4.7	7	25	40	0.5	6	105125	Δ		Δ
L105.1833.5.H.6	0.2	3.3	5.7	4.7	7	30	45	0.5	6	105125	Δ		Δ
L105.1840.3.H.7	0.2	4	6.4	5.2	7	20	35	0.5	7	105125	Δ		Δ
L105.1840.4.H.7	0.2	4	6.4	5.2	7	25	40	0.5	7	105125	Δ		Δ
L105.1840.5.H.7	0.2	4	6.4	5.2	7	30	45	0.5	7	105125	Δ		Δ

Dimensions in mm

P	●	●	●
M	●	●	●
K	●	●	●
N	○	○	-
S	-	○	-
H	-	-	-

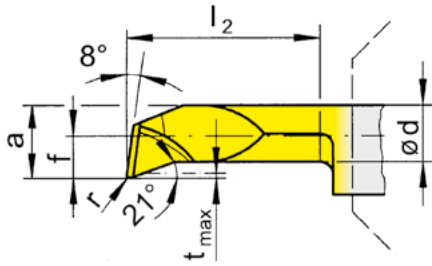
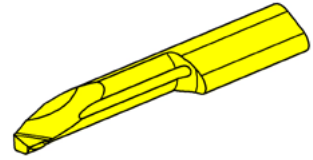
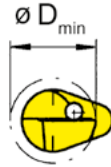
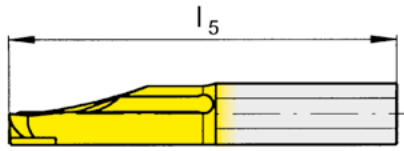
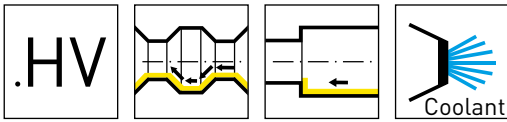

Coating grades

R = right hand version shown

L = left hand version

▲ In stock

Δ 2 weeks

Part number	r	f	a	d	b	l ₂	l ₅	t _{max}	D _{min}	HIS	EG35	IG35	TH35
R105.1819.1.HV4	0.2	1.9	3.7	2.9	7	10	25	0.3	4	105125	Δ		▲
R105.1819.2.HV4	0.2	1.9	3.7	2.9	7	15	30	0.3	4	105125	Δ		▲
R105.1819.3.HV4	0.2	1.9	3.7	2.9	7	20	35	0.3	4	105125	Δ		▲
R105.1823.1.HV5	0.2	2.3	4.7	4	7	10	25	0.5	5	105125	Δ	▲	▲
R105.1823.2.HV5	0.2	2.3	4.7	4	7	15	30	0.5	5	105125	Δ		▲
R105.1823.3.HV5	0.2	2.3	4.7	4	7	20	35	0.5	5	105125	▲	▲	▲
R105.1823.4.HV5	0.2	2.3	4.7	4	7	25	40	0.5	5	105125	Δ	▲	▲
R105.1823.5.HV5	0.2	2.3	4.7	4	7	30	45	0.5	5	105125	Δ		▲
L105.1819.1.HV4	0.2	1.9	3.7	2.9	7	10	25	0.3	4	105125	Δ		▲
L105.1819.2.HV4	0.2	1.9	3.7	2.9	7	15	30	0.3	4	105125	Δ		▲
L105.1819.3.HV4	0.2	1.9	3.7	2.9	7	20	35	0.3	4	105125	Δ		▲
L105.1823.1.HV5	0.2	2.3	4.7	4	7	10	25	0.5	5	105125	Δ		▲
L105.1823.2.HV5	0.2	2.3	4.7	4	7	15	30	0.5	5	105125	Δ		▲
L105.1823.3.HV5	0.2	2.3	4.7	4	7	20	35	0.5	5	105125	Δ		▲
L105.1823.4.HV5	0.2	2.3	4.7	4	7	25	40	0.5	5	105125	Δ		▲
L105.1823.5.HV5	0.2	2.3	4.7	4	7	30	45	0.5	5	105125			▲

Dimensions in mm

P	●	●	●
M	●	●	●
K	●	●	●
N	o	o	-
S	-	o	-
H	-	-	-

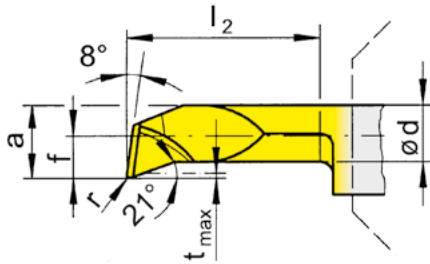
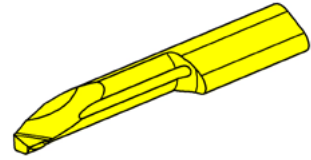
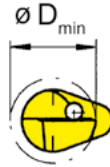
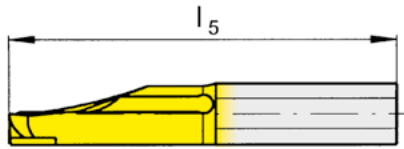
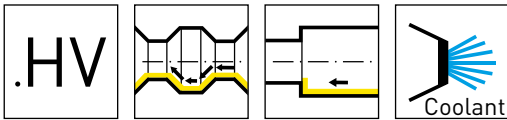

Coating grades

R = right hand version shown

L = left hand version

▲ In stock

Δ 2 weeks

Part number	r	f	a	d	b	l ₂	l ₅	t _{max}	D _{min}	HIS	EG35	IG35	TH35
R105.1833.2.HV6	0.2	3.3	5.7	4.7	7	15	30	0.5	6	105125	Δ	▲	▲
R105.1833.3.HV6	0.2	3.3	5.7	4.7	7	20	35	0.5	6	105125	Δ		▲
R105.1833.4.HV6	0.2	3.3	5.7	4.7	7	25	40	0.5	6	105125	Δ		▲
R105.1833.5.HV6	0.2	3.3	5.7	4.7	7	30	45	0.5	6	105125	Δ		▲
R105.1840.2.HV7	0.2	4	6.4	5.2	7	15	30	0.5	7	105125	Δ		▲
R105.1840.3.HV7	0.2	4	6.4	5.2	7	20	35	0.5	7	105125	Δ		▲
R105.1840.4.HV7	0.2	4	6.4	5.2	7	25	40	0.5	7	105125	▲		▲
R105.1840.5.HV7	0.2	4	6.4	5.2	7	30	45	0.5	7	105125	Δ	▲	▲
L105.1833.2.HV6	0.2	3.3	5.7	4.7	7	15	30	0.5	6	105125	Δ		▲
L105.1833.3.HV6	0.2	3.3	5.7	4.7	7	20	35	0.5	6	105125	Δ		▲
L105.1833.4.HV6	0.2	3.3	5.7	4.7	7	25	40	0.5	6	105125	▲		▲
L105.1833.5.HV6	0.2	3.3	5.7	4.7	7	30	45	0.5	6	105125	Δ		▲
L105.1840.2.HV7	0.2	4	6.4	5.2	7	15	30	0.5	7	105125	Δ		▲
L105.1840.3.HV7	0.2	4	6.4	5.2	7	20	35	0.5	7	105125			▲
L105.1840.4.HV7	0.2	4	6.4	5.2	7	25	40	0.5	7	105125	Δ		▲
L105.1840.5.HV7	0.2	4	6.4	5.2	7	30	45	0.5	7	105125	Δ		▲
P	●	●	●										
M	●	●	●										
K	●	●	●										
N	o	o	-										
S	-	o	-										
H	-	-	-										

Dimensions in mm

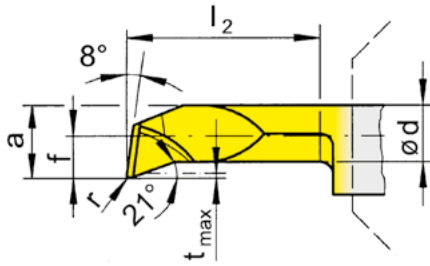
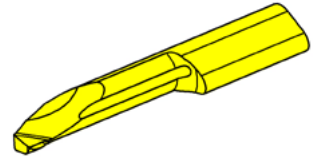
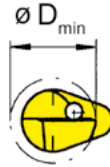
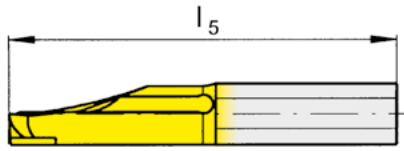
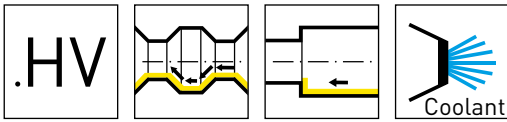

Coating grades

R = right hand version shown

L = left hand version

▲ In stock

Δ 2 weeks

Part number	r	f	a	d	b	l ₂	l ₅	t _{max}	D _{min}	HIS	EG35	IG35	TH35
R105.1819.04.1.HV4	0.4	1.9	3.7	2.9	7	10	25	0.3	4	105125	Δ		▲
R105.1819.04.2.HV4	0.4	1.9	3.7	2.9	7	15	30	0.3	4	105125	▲		▲
R105.1819.04.3.HV4	0.4	1.9	3.7	2.9	7	20	35	0.3	4	105125	Δ		▲
R105.1823.04.1.HV5	0.4	2.3	4.7	4	7	10	25	0.5	5	105125	Δ	▲	▲
R105.1823.04.2.HV5	0.4	2.3	4.7	4	7	15	30	0.5	5	105125	▲	▲	▲
R105.1823.04.3.HV5	0.4	2.3	4.7	4	7	20	35	0.5	5	105125	Δ		▲
R105.1823.04.4.HV5	0.4	2.3	4.7	4	7	25	40	0.5	5	105125	Δ		▲
R105.1823.04.5.HV5	0.4	2.3	4.7	4	7	30	45	0.5	5	105125	Δ		▲
L105.1819.04.1.HV4	0.4	1.9	3.7	2.9	7	10	25	0.3	4	105125	Δ		▲
L105.1819.04.2.HV4	0.4	1.9	3.7	2.9	7	15	30	0.3	4	105125	Δ		▲
L105.1819.04.3.HV4	0.4	1.9	3.7	2.9	7	20	35	0.3	4	105125	Δ		▲
L105.1823.04.1.HV5	0.4	2.3	4.7	4	7	10	25	0.5	5	105125	Δ		▲
L105.1823.04.2.HV5	0.4	2.3	4.7	4	7	15	30	0.5	5	105125	Δ		▲
L105.1823.04.3.HV5	0.4	2.3	4.7	4	7	20	35	0.5	5	105125	Δ		Δ
L105.1823.04.4.HV5	0.4	2.3	4.7	4	7	25	40	0.5	5	105125	Δ		▲
L105.1823.04.5.HV5	0.4	2.3	4.7	4	7	30	45	0.5	5	105125	Δ		▲

Dimensions in mm

P	●	●	●
M	●	●	●
K	●	●	●
N	○	○	-
S	-	○	-
H	-	-	-

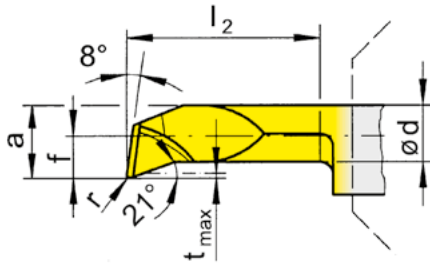
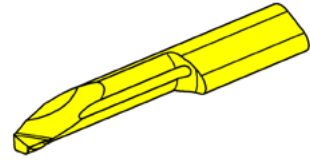
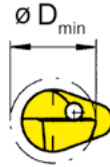
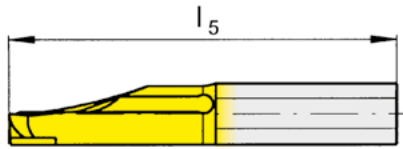
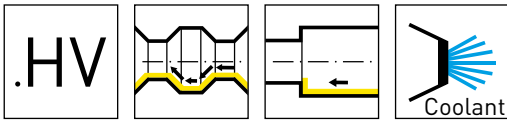

Coating grades

R = right hand version shown

L = left hand version

▲ In stock

Δ 2 weeks

Part number	r	f	a	d	b	l ₂	l ₅	t _{max}	D _{min}	HIS	EG35	TH35
R105.1833.04.2.HV6	0.4	3.3	5.7	4.7	7	15	30	0.5	6	105125	Δ	▲
R105.1833.04.3.HV6	0.4	3.3	5.7	4.7	7	20	35	0.5	6	105125	Δ	▲
R105.1833.04.4.HV6	0.4	3.3	5.7	4.7	7	25	40	0.5	6	105125	Δ	▲
R105.1833.04.5.HV6	0.4	3.3	5.7	4.7	7	30	45	0.5	6	105125	Δ	▲
R105.1840.04.2.HV7	0.4	4	6.4	5.2	7	15	30	0.5	7	105125	Δ	▲
R105.1840.04.3.HV7	0.4	4	6.4	5.2	7	20	35	0.5	7	105125	Δ	▲
R105.1840.04.4.HV7	0.4	4	6.4	5.2	7	25	40	0.5	7	105125	Δ	▲
R105.1840.04.5.HV7	0.4	4	6.4	5.2	7	30	45	0.5	7	105125	Δ	▲
L105.1833.04.2.HV6	0.4	3.3	5.7	4.7	7	15	30	0.5	6	105125		▲
L105.1833.04.3.HV6	0.4	3.3	5.7	4.7	7	20	35	0.5	6	105125	Δ	▲
L105.1833.04.4.HV6	0.4	3.3	5.7	4.7	7	25	40	0.5	6	105125	Δ	▲
L105.1833.04.5.HV6	0.4	3.3	5.7	4.7	7	30	45	0.5	6	105125	Δ	▲
L105.1840.04.2.HV7	0.4	4	6.4	5.2	7	15	30	0.5	7	105125	Δ	▲
L105.1840.04.3.HV7	0.4	4	6.4	5.2	7	20	35	0.5	7	105125	Δ	▲
L105.1840.04.4.HV7	0.4	4	6.4	5.2	7	25	40	0.5	7	105125	Δ	▲
L105.1840.04.5.HV7	0.4	4	6.4	5.2	7	30	45	0.5	7	105125		▲

Dimensions in mm

P	●	●
M	●	●
K	●	●
N	o	-
S	-	-
H	-	-

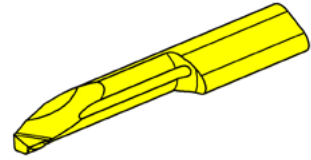
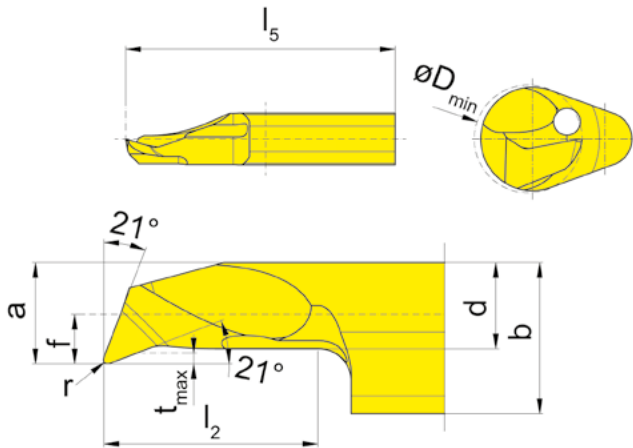
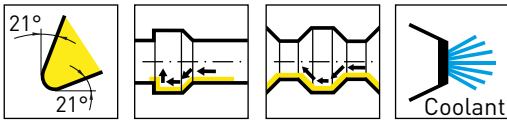

Coating grades

R = right hand version shown

L = left hand version

▲ In stock

△ 2 weeks

Part number	r	f	a	d	b	l_2	l_5	t_{max}	D_{min}	HIS	EG35	IG35
R105.2113.1.3	0.1	1.3	2.6	2.3	5.9	10	25	0.15	3	105123	▲	▲
R105.2113.2.3	0.1	1.3	2.6	2.3	5.9	15	30	0.15	3	105123	▲	▲
R105.2113.3.3	0.1	1.3	2.6	2.3	5.9	20	35	0.15	3	105123	▲	▲
R105.2119.1.4	0.15	1.9	3.7	3	6.4	10	25	0.3	4	105124	▲	▲
R105.2119.2.4	0.15	1.9	3.7	3	6.4	15	30	0.3	4	105124	▲	▲
R105.2119.3.4	0.15	1.9	3.7	3	6.4	20	35	0.3	4	105124	▲	▲
R105.2119.4.4	0.15	1.9	3.7	3	6.4	25	40	0.3	4	105124	△	▲
R105.2123.1.5	0.2	2.3	4.7	4	7	10	25	0.5	5	105125	△	▲
R105.2123.2.5	0.2	2.3	4.7	4	7	15	30	0.5	5	105125	▲	▲
R105.2123.3.5	0.2	2.3	4.7	4	7	20	35	0.5	5	105125	▲	▲
R105.2123.4.5	0.2	2.3	4.7	4	7	25	40	0.5	5	105125	△	▲
R105.2123.5.5	0.2	2.3	4.7	4	7	30	45	0.5	5	105125	△	▲
R105.2123.6.5	0.2	2.3	4.7	4	7	35	50	0.5	5	105125	△	▲
L105.2113.1.3	0.1	1.3	2.6	2.3	5.9	10	25	0.15	3	105123	▲	
L105.2113.2.3	0.1	1.3	2.6	2.3	5.9	15	30	0.15	3	105123	▲	
L105.2113.3.3	0.1	1.3	2.6	2.3	5.9	20	35	0.15	3	105123	▲	
L105.2119.1.4	0.15	1.9	3.7	3	6.4	10	25	0.3	4	105124	▲	
L105.2119.2.4	0.15	1.9	3.7	3	6.4	15	30	0.3	4	105124	▲	
L105.2119.3.4	0.15	1.9	3.7	3	6.4	20	35	0.3	4	105124	▲	
L105.2119.4.4	0.15	1.9	3.7	3	6.4	25	40	0.3	4	105124	△	
L105.2123.1.5	0.2	2.3	4.7	4	7	10	25	0.5	5	105125	△	
L105.2123.2.5	0.2	2.3	4.7	4	7	15	30	0.5	5	105125	▲	
L105.2123.3.5	0.2	2.3	4.7	4	7	20	35	0.5	5	105125	▲	
L105.2123.4.5	0.2	2.3	4.7	4	7	25	40	0.5	5	105125	△	
L105.2123.5.5	0.2	2.3	4.7	4	7	30	45	0.5	5	105125	△	
L105.2123.6.5	0.2	2.3	4.7	4	7	35	50	0.5	5	105125	△	

Dimensions in mm

P	●	●
M	●	●
K	●	●
N	○	○
S	-	○
H	-	-

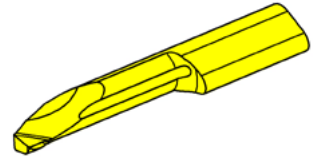
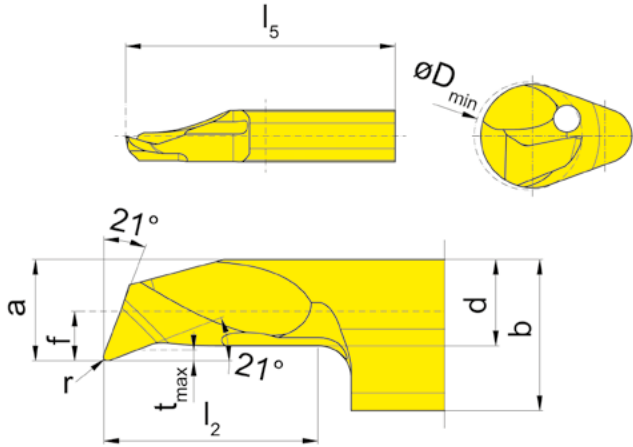
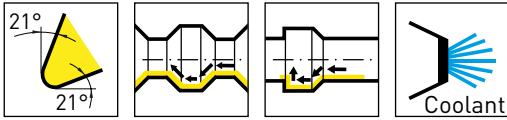

Coating grades

R = right hand version shown

L = left hand version

▲ In stock

△ 2 weeks

Part number	r	f	a	d	b	l ₂	l ₅	t _{max}	D _{min}	HIS	EG35	IG35
R105.2133.1.6	0.2	3.3	5.7	4.7	7	10	25	0.5	6	105125	▲	▲
R105.2133.2.6	0.2	3.3	5.7	4.7	7	15	30	0.5	6	105125	▲	▲
R105.2133.3.6	0.2	3.3	5.7	4.7	7	20	35	0.5	6	105125	▲	▲
R105.2133.4.6	0.2	3.3	5.7	4.7	7	25	40	0.5	6	105125	△	▲
R105.2133.5.6	0.2	3.3	5.7	4.7	7	30	45	0.5	6	105125	△	▲
R105.2133.6.6	0.2	3.3	5.7	4.7	7	35	50	0.5	6	105125	△	▲
R105.2140.1.7	0.2	4	6.4	5.2	7	10	25	0.5	7	105125	▲	▲
R105.2140.2.7	0.2	4	6.4	5.2	7	15	30	0.5	7	105125	▲	▲
R105.2140.3.7	0.2	4	6.4	5.2	7	20	35	0.5	7	105125	▲	▲
R105.2140.4.7	0.2	4	6.4	5.2	7	25	40	0.5	7	105125	△	▲
R105.2140.5.7	0.2	4	6.4	5.2	7	30	45	0.5	7	105125	△	▲
R105.2140.6.7	0.2	4	6.4	5.2	7	35	50	0.5	7	105125	△	▲
L105.2133.1.6	0.2	3.3	5.7	4.7	7	10	25	0.5	6	105125	▲	
L105.2133.2.6	0.2	3.3	5.7	4.7	7	15	30	0.5	6	105125	▲	
L105.2133.3.6	0.2	3.3	5.7	4.7	7	20	35	0.5	6	105125	▲	
L105.2133.4.6	0.2	3.3	5.7	4.7	7	25	40	0.5	6	105125	△	
L105.2133.5.6	0.2	3.3	5.7	4.7	7	30	45	0.5	6	105125	△	
L105.2133.6.6	0.2	3.3	5.7	4.7	7	35	50	0.5	6	105125	△	
L105.2140.1.7	0.2	4	6.4	5.2	7	10	25	0.5	7	105125	▲	
L105.2140.2.7	0.2	4	6.4	5.2	7	15	30	0.5	7	105125	▲	
L105.2140.3.7	0.2	4	6.4	5.2	7	20	35	0.5	7	105125	▲	
L105.2140.4.7	0.2	4	6.4	5.2	7	25	40	0.5	7	105125	△	
L105.2140.5.7	0.2	4	6.4	5.2	7	30	45	0.5	7	105125	△	
L105.2140.6.7	0.2	4	6.4	5.2	7	35	50	0.5	7	105125	△	

Dimensions in mm

P	●	●
M	●	●
K	●	●
N	○	○
S	-	○
H	-	-

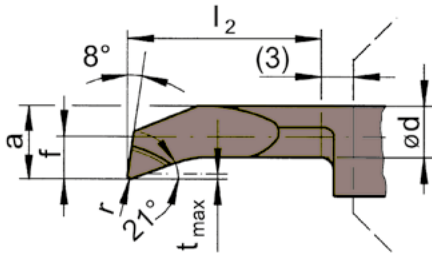
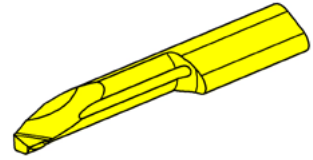
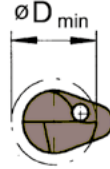
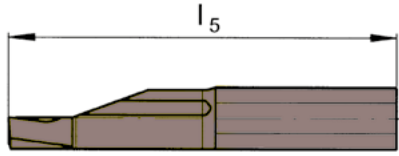
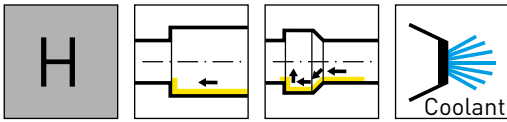

Coating grades

R = right hand version shown

L = left hand version

▲ In stock

Δ 2 weeks

Part number	r	f	a	d	b	l ₂	l ₅	t _{max}	D _{min}	HIS	SG36
R105.1819.01.1.4F	0.1	1.9	3.7	2.9	6.4	10	25	0.3	4	105124	▲
R105.1819.01.2.4F	0.1	1.9	3.7	2.9	6.4	15	30	0.3	4	105124	▲
R105.1823.15.2.5F	0.15	2.3	4.7	4	7	15	30	0.5	5	105125	▲
R105.1823.15.3.5F	0.15	2.3	4.7	4	7	20	35	0.5	5	105125	▲
L105.1819.01.1.4F	0.1	1.9	3.7	2.9	6.4	10	25	0.3	4	105124	▲
L105.1819.01.2.4F	0.1	1.9	3.7	2.9	6.4	15	30	0.3	4	105124	▲
L105.1823.15.2.5F	0.15	2.3	4.7	4	7	15	30	0.5	5	105125	▲
L105.1823.15.3.5F	0.15	2.3	4.7	4	7	20	35	0.5	5	105125	▲

These inserts use a high hardness, high temperature carbide grade designed for ISO groups S and H

Suitable for materials with hardness up to 60 HRC

Dimensions in mm

P	o
M	o
K	-
N	-
S	•
H	•

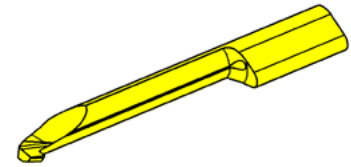
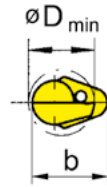
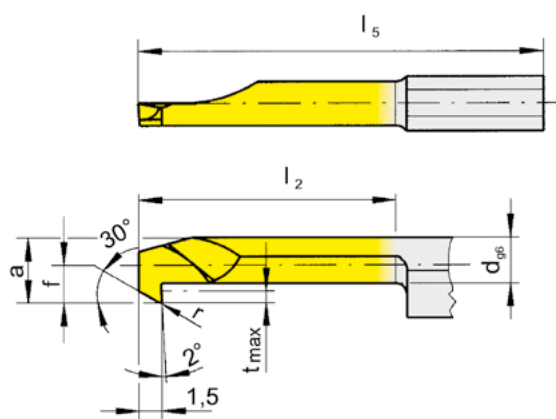
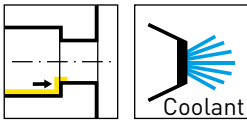

Coating grades

R = right hand version shown

L = left hand version

▲ In stock

△ 2 weeks

Part number	r	f	a	d	b	l ₂	l ₅	t _{max}	D _{min}	HIS	EG35	IG35	TH35	TI25
R105.3013.2.3	0.1	1.3	2.6	1.9	5.9	15	30	0.5	3	105123	▲			▲
R105.3013.3.3	0.1	1.3	2.6	1.9	5.9	20	35	0.5	3	105123	▲			▲
R105.3019.2.4	0.15	1.9	3.7	2.7	6.4	15	30	0.8	4	105124	▲	▲	▲	▲
R105.3019.4.4	0.15	1.9	3.7	2.7	6.4	25	40	0.8	4	105124	▲			▲
R105.3023.3.5	0.2	2.3	4.7	3.5	7	20	35	1	5	105125	▲	▲		▲
R105.3023.5.5	0.2	2.3	4.7	3.5	7	30	45	1	5	105125	▲			▲
R105.3033.3.6	0.2	3.3	5.7	3.7	7	20	35	1.8	6	105125	▲	▲		▲
R105.3033.5.6	0.2	3.3	5.7	3.7	7	30	45	1.8	6	105125	▲			▲
R105.3040.3.7	0.2	4	6.4	3.7	7	20	35	2.5	6.8	105125	▲			▲
R105.3040.5.7	0.2	4	6.4	3.7	7	30	45	2.5	6.8	105125	▲			▲
L105.3013.2.3	0.1	1.3	2.6	1.9	5.9	15	30	0.5	3	105123	△			▲
L105.3013.3.3	0.1	1.3	2.6	1.9	5.9	20	35	0.5	3	105123	△			△
L105.3019.2.4	0.15	1.9	3.7	2.7	6.4	15	30	0.8	4	105124				▲
L105.3019.4.4	0.15	1.9	3.7	2.7	6.4	25	40	0.8	4	105124	△			△
L105.3023.3.5	0.2	2.3	4.7	3.5	7	20	35	1	5	105125	▲			▲
L105.3023.5.5	0.2	2.3	4.7	3.5	7	30	45	1	5	105125	△			△
L105.3033.3.6	0.2	3.3	5.7	3.7	7	20	35	1.8	6	105125	△			▲
L105.3033.5.6	0.2	3.3	5.7	3.7	7	30	45	1.8	6	105125	△			△
L105.3040.3.7	0.2	4	6.4	3.7	7	20	35	2.5	6.8	105125	▲			▲
L105.3040.5.7	0.2	4	6.4	3.7	7	30	45	2.5	6.8	105125	△			▲

Dimensions in mm

P	●	●	●	●
M	●	●	●	●
K	●	●	●	-
N	○	○	-	●
S	-	○	-	-
H	-	-	-	-

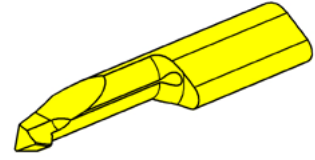
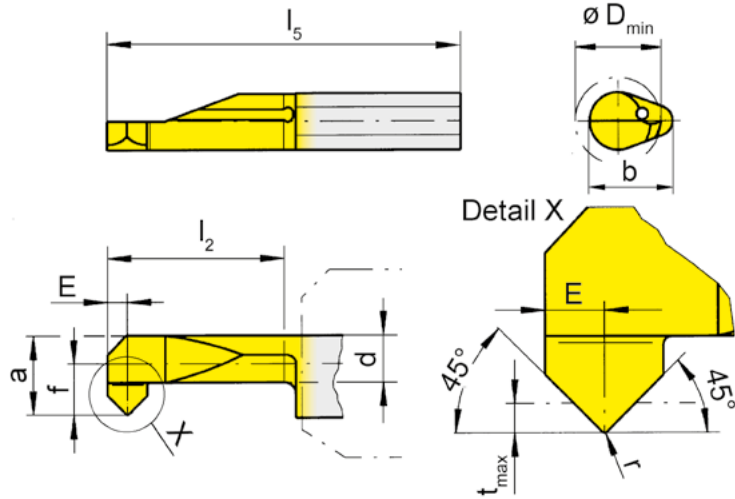
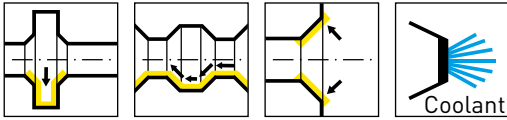

Coating grades

R = right hand version shown

L = left hand version

▲ In stock

△ 2 weeks

Part number	r	f	E	a	d	b	l ₂	l ₅	t _{max}	D _{min}	HIS	Coating grades			
												EG35	TH35	TN35	
R105.4545.1.3	0.2	1.4	1	2.7	1.9	5.9	10	25	0.5	3	105123		▲		
R105.4545.1.4	0.2	1.9	1	3.7	2.8	6.4	10	25	0.7	4	105124		▲		
R105.4545.2.5	0.2	2.3	1	4.7	3.5	7	15	30	0.7	5	105125	▲		▲	
R105.4545.3.7	0.2	4	1	6.4	4.7	7	20	35	0.7	7	105125	▲		▲	
L105.4545.1.3	0.2	1.4	1	2.7	1.9	5.9	10	25	0.5	3	105123		▲		
L105.4545.1.4	0.2	1.9	1	3.7	2.8	6.4	10	25	0.7	4	105124		▲		
L105.4545.2.5	0.2	2.3	1	4.7	3.5	7	15	30	0.7	5	105125	▲		▲	
L105.4545.3.7	0.2	4	1	6.4	4.7	7	20	35	0.7	7	105125	▲		▲	
Dimensions in mm												P	●	●	●
												M	●	●	-
												K	●	●	●
												N	○	-	○
												S	-	-	-
												H	-	-	-

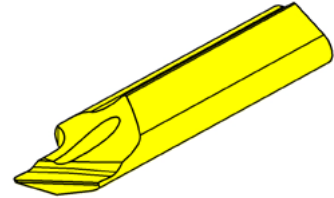
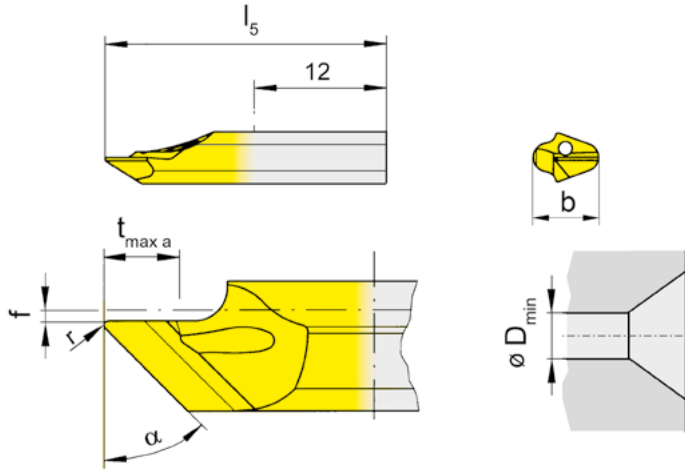
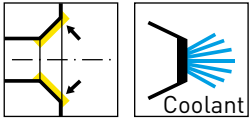

Coating grades

R = right hand version shown

L = left hand version

▲ In stock

Δ 2 weeks

Part number	r	f	b	l_5	$t_{max a}$	D_{min}	α	HIS	EG35	TH35	TN35	
R105.0045.0.1	0.2	0.5	5.9	20	3.5	1	45°	105123	▲	▲	▲	
R105.0045.1.1	0.2	0.5	5.9	25	3.5	1	45°	105123	▲	▲		
R105.0060.0.1	0.2	0.5	5.9	20	4	1	60°	105123	▲	▲		
R105.0060.1.1	0.2	0.5	5.9	25	4	1	60°	105123	▲	▲		
L105.0045.0.1	0.2	0.5	5.9	20	3.5	1	45°	105123	▲		▲	
L105.0045.1.1	0.2	0.5	5.9	25	3.5	1	45°	105123	▲	▲		
L105.0060.0.1	0.2	0.5	5.9	20	4	1	60°	105123	▲	▲		
L105.0060.1.1	0.2	0.5	5.9	25	4	1	60°	105123	▲	▲		
Dimensions in mm									P	●	●	●
									M	●	●	-
									K	●	●	●
									N	○	-	○
									S	-	-	-
									H	-	-	-

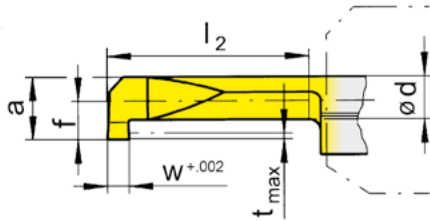
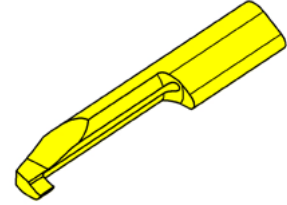
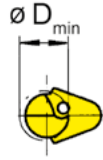
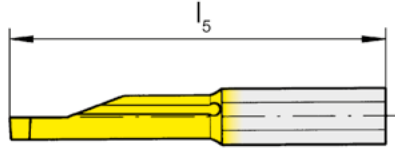
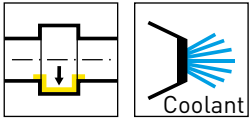

Coating grades

R = right hand version shown

L = left hand version

▲ In stock

Δ 2 weeks

Part number	w	f	a	d	b	l_2	l_5	t_{max}	D_{min}	HIS		MG12	IG35	TH35	TN35
RU105.0031.1.4	.031	.075	.146	.106	.252	.394	.984	.031	.157	105124	▲	▲	▲	▲	
RU105.0031.2.4	.031	.075	.146	.106	.252	.591	1.181	.031	.157	105124	▲	▲	▲	▲	
RU105.0031.3.4	.031	.075	.146	.106	.252	.787	1.378	.031	.157	105124		▲	▲	▲	
LU105.0031.1.4	.031	.075	.146	.106	.252	.394	.984	.031	.157	105124		▲	▲	▲	
LU105.0031.2.4	.031	.075	.146	.106	.252	.591	1.181	.031	.157	105124		▲	▲	▲	
LU105.0031.3.4	.031	.075	.146	.106	.252	.787	1.378	.031	.157	105124		▲	▲	▲	

Dimensions in inch



P	-	●	●	●
M	-	●	●	-
K	-	●	●	●
N	●	○	-	○
S	-	○	-	-
H	-	-	-	-

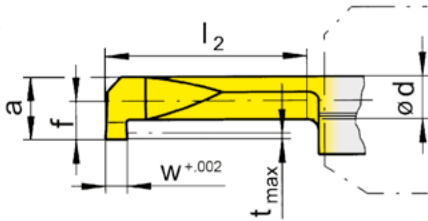
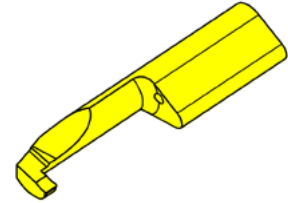
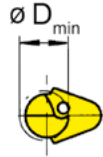
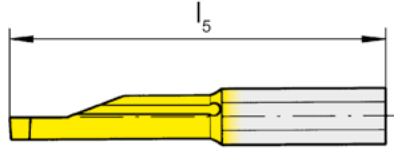
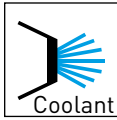
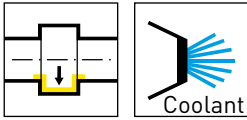

Coating grades

R = right hand version shown

L = left hand version

▲ In stock

Δ 2 weeks

Part number	w	f	a	d	b	l ₂	l ₅	t _{max}	D _{min}	HIS	IG35	TH35	TI25	TN35
RU105.0031.1.5	.031	.091	.185	.138	.276	.394	.984	.039	.197	105125	▲	▲		▲
RU105.0031.2.5	.031	.091	.185	.138	.276	.591	1.181	.039	.197	105125	▲	▲		▲
RU105.0031.3.5	.031	.091	.185	.138	.276	.787	1.378	.039	.197	105125	▲	▲		▲
RU105.0031.4.5	.031	.091	.185	.138	.276	.984	1.575	.039	.197	105125	▲	▲		▲
RU105.0031.5.5	.031	.091	.185	.138	.276	1.181	1.772	.039	.197	105125	▲	▲		▲
RU105.0046.1.5	.046	.091	.185	.138	.276	.394	.984	.039	.197	105125	▲	▲	Δ	▲
RU105.0046.2.5	.046	.091	.185	.138	.276	.591	1.181	.039	.197	105125	▲	▲		▲
RU105.0046.3.5	.046	.091	.185	.138	.276	.787	1.378	.039	.197	105125	▲	▲		▲
RU105.0046.4.5	.046	.091	.185	.138	.276	.984	1.575	.039	.197	105125	▲	▲		▲
RU105.0046.5.5	.046	.091	.185	.138	.276	1.181	1.772	.039	.197	105125	▲	▲		▲
LU105.0031.1.5	.031	.091	.185	.138	.276	.394	.984	.039	.197	105125	▲			▲
LU105.0031.2.5	.031	.091	.185	.138	.276	.591	1.181	.039	.197	105125	▲			▲
LU105.0031.3.5	.031	.091	.185	.138	.276	.787	1.378	.039	.197	105125	▲			▲
LU105.0031.4.5	.031	.091	.185	.138	.276	.984	1.575	.039	.197	105125	▲			▲
LU105.0031.5.5	.031	.091	.185	.138	.276	1.181	1.772	.039	.197	105125	▲			▲
LU105.0046.1.5	.046	.091	.185	.138	.276	.394	.984	.039	.197	105125	▲			▲
LU105.0046.2.5	.046	.091	.185	.138	.276	.591	1.181	.039	.197	105125	▲			▲
LU105.0046.3.5	.046	.091	.185	.138	.276	.787	1.378	.039	.197	105125	▲			▲
LU105.0046.4.5	.046	.091	.185	.138	.276	.984	1.575	.039	.197	105125	▲			▲
LU105.0046.5.5	.046	.091	.185	.138	.276	1.181	1.772	.039	.197	105125	▲			▲

Dimensions in inch



P	●	●	●	●
M	●	●	●	-
K	●	●	●	●
N	○	-	●	○
S	○	-	-	-
H	-	-	-	-

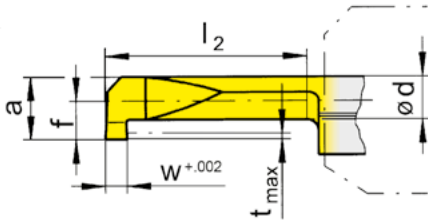
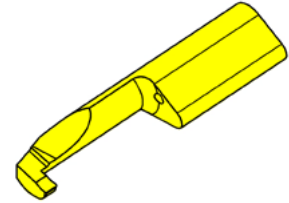
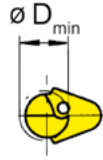
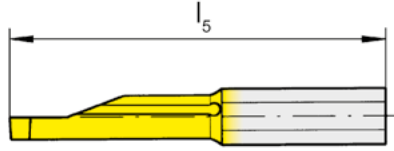
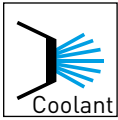
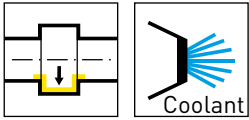

Coating grades

R = right hand version shown

L = left hand version

▲ In stock

Δ 2 weeks

Part number	w	f	a	d	b	l ₂	l ₅	t _{max}	D _{min}	HIS	IG35	TH35	TN35
RU105.0062.1.5	.062	.091	.185	.138	.276	.394	.984	.039	.197	105125	▲	▲	▲
RU105.0062.2.5	.062	.091	.185	.138	.276	.591	1.181	.039	.197	105125	▲	▲	▲
RU105.0062.3.5	.062	.091	.185	.138	.276	.787	1.378	.039	.197	105125	▲	▲	▲
RU105.0062.4.5	.062	.091	.185	.138	.276	.984	1.575	.039	.197	105125	▲	▲	▲
RU105.0078.1.5	.078	.091	.185	.138	.276	.394	.984	.039	.197	105125	▲	▲	▲
RU105.0078.2.5	.078	.091	.185	.138	.276	.591	1.181	.039	.197	105125	▲	▲	▲
RU105.0078.3.5	.078	.091	.185	.138	.276	.787	1.378	.039	.197	105125	▲	▲	▲
RU105.0078.4.5	.078	.091	.185	.138	.276	.984	1.575	.039	.197	105125	▲	▲	▲
RU105.0078.5.5	.078	.091	.185	.138	.276	1.181	1.772	.039	.197	105125	▲	▲	▲
LU105.0062.1.5	.062	.091	.185	.138	.276	.394	.984	.039	.197	105125	▲		▲
LU105.0062.2.5	.062	.091	.185	.138	.276	.591	1.181	.039	.197	105125	▲		▲
LU105.0062.3.5	.062	.091	.185	.138	.276	.787	1.378	.039	.197	105125	▲		▲
LU105.0062.4.5	.062	.091	.185	.138	.276	.984	1.575	.039	.197	105125	▲		▲
LU105.0078.1.5	.078	.091	.185	.138	.276	.394	.984	.039	.197	105125	▲		▲
LU105.0078.2.5	.078	.091	.185	.138	.276	.591	1.181	.039	.197	105125	▲		▲
LU105.0078.3.5	.078	.091	.185	.138	.276	.787	1.378	.039	.197	105125	▲		▲
LU105.0078.4.5	.078	.091	.185	.138	.276	.984	1.575	.039	.197	105125	▲		▲
LU105.0078.5.5	.078	.091	.185	.138	.276	1.181	1.772	.039	.197	105125	▲		▲

Dimensions in inch



P	●	●	●
M	●	●	-
K	●	●	●
N	o	-	o
S	o	-	-
H	-	-	-

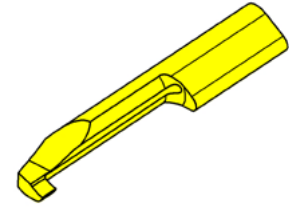
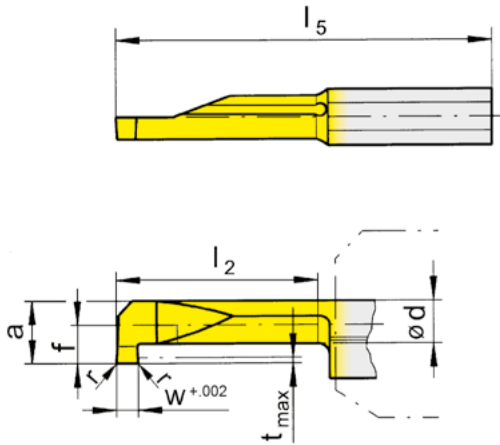
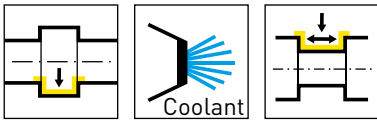

Coating grades

R = right hand version shown

L = left hand version

▲ In stock

Δ 2 weeks

Part number	w	f	a	d	b	l ₂	l ₅	t _{max}	D _{min}	HIS	MG12	IG35	TH35	TI25	TN35
RU105.0031.1.6	.031	.130	.224	.146	.276	.394	.984	.071	.236	105125	▲	▲	▲		▲
RU105.0031.2.6	.031	.130	.224	.146	.276	.591	1.181	.071	.236	105125		▲	▲		▲
RU105.0031.3.6	.031	.130	.224	.146	.276	.787	1.378	.071	.236	105125	▲	▲	▲		▲
RU105.0031.4.6	.031	.130	.224	.146	.276	.984	1.575	.071	.236	105125	▲	▲	▲	Δ	▲
RU105.0031.5.6	.031	.130	.224	.146	.276	1.181	1.772	.071	.236	105125		▲	▲		▲
RU105.0046.1.6	.046	.130	.224	.146	.276	.394	.984	.071	.236	105125		▲	▲		▲
RU105.0046.2.6	.046	.130	.224	.146	.276	.591	1.181	.071	.236	105125		▲	▲		▲
RU105.0046.3.6	.046	.130	.224	.146	.276	.787	1.378	.071	.236	105125		▲	▲		▲
RU105.0046.4.6	.046	.130	.224	.146	.276	.984	1.575	.071	.236	105125		▲	▲		▲
RU105.0046.5.6	.046	.130	.224	.146	.276	1.181	1.772	.071	.236	105125		▲	▲		▲
LU105.0031.1.6	.031	.130	.224	.146	.276	.394	.984	.071	.236	105125		▲			▲
LU105.0031.2.6	.031	.130	.224	.146	.276	.591	1.181	.071	.236	105125		▲			▲
LU105.0031.3.6	.031	.130	.224	.146	.276	.787	1.378	.071	.236	105125		▲			▲
LU105.0031.4.6	.031	.130	.224	.146	.276	.984	1.575	.071	.236	105125		▲			▲
LU105.0046.1.6	.046	.130	.224	.146	.276	.394	.984	.071	.236	105125		▲			▲
LU105.0046.2.6	.046	.130	.224	.146	.276	.591	1.181	.071	.236	105125		▲			▲
LU105.0046.3.6	.046	.130	.224	.146	.276	.787	1.378	.071	.236	105125		▲			▲
LU105.0046.4.6	.046	.130	.224	.146	.276	.984	1.575	.071	.236	105125		▲			▲
LU105.0046.5.6	.046	.130	.224	.146	.276	1.181	1.772	.071	.236	105125		▲			▲

Dimensions in inch



P	-	●	●	●	●
M	-	●	●	●	-
K	-	●	●	●	●
N	●	○	-	●	○
S	-	○	-	-	-
H	-	-	-	-	-

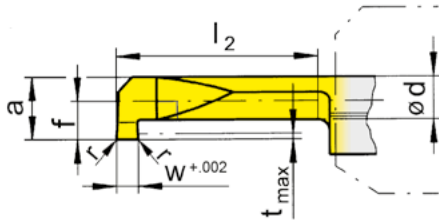
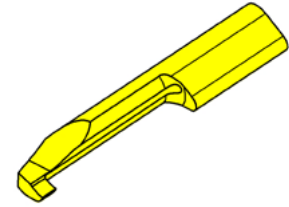
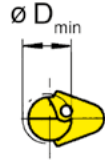
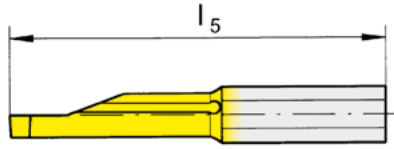
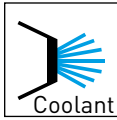
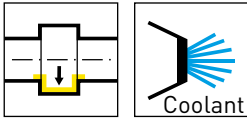

Coating grades

R = right hand version shown

L = left hand version

▲ In stock

Δ 2 weeks

Part number	w	f	a	d	b	l ₂	l ₅	t _{max}	D _{min}	HIS	MG12	IG35	TH35	TI25	TN35
RU105.0062.1.6	.062	.130	.224	.146	.276	.394	.984	.071	.236	105125		▲	▲		▲
RU105.0062.2.6	.062	.130	.224	.146	.276	.591	1.181	.071	.236	105125		▲	▲		▲
RU105.0062.3.6	.062	.130	.224	.146	.276	.787	1.378	.071	.236	105125	▲	▲	▲		▲
RU105.0062.4.6	.062	.130	.224	.146	.276	.984	1.575	.071	.236	105125		▲	▲	Δ	▲
RU105.0078.1.6	.078	.130	.224	.146	.276	.394	.984	.071	.236	105125	▲	▲	▲		▲
RU105.0078.2.6	.078	.130	.224	.146	.276	.591	1.181	.071	.236	105125	▲	▲	▲		▲
RU105.0078.3.6	.078	.130	.224	.146	.276	.787	1.378	.071	.236	105125		▲	▲		▲
RU105.0078.4.6	.078	.130	.224	.146	.276	.984	1.575	.071	.236	105125		▲	▲		▲
RU105.0062.5.6	.062	.130	.224	.146	.276	1.181	1.772	.071	.236	105125		▲	▲		▲
RU105.0078.5.6	.078	.130	.224	.146	.276	1.181	1.772	.071	.236	105125		▲	▲		▲
LU105.0062.1.6	.062	.130	.224	.146	.276	.394	.984	.071	.236	105125		▲			▲
LU105.0062.2.6	.062	.130	.224	.146	.276	.591	1.181	.071	.236	105125		▲			▲
LU105.0062.3.6	.062	.130	.224	.146	.276	.787	1.378	.071	.236	105125		▲			▲
LU105.0062.4.6	.062	.130	.224	.146	.276	.984	1.575	.071	.236	105125		▲			▲
LU105.0078.1.6	.078	.130	.224	.146	.276	.394	.984	.071	.236	105125		▲			▲
LU105.0078.2.6	.078	.130	.224	.146	.276	.591	1.181	.071	.236	105125		▲			▲
LU105.0078.3.6	.078	.130	.224	.146	.276	.787	1.378	.071	.236	105125		▲			▲
LU105.0078.4.6	.078	.130	.224	.146	.276	.984	1.575	.071	.236	105125		▲			▲

Dimensions in inch



P	-	●	●	●	●
M	-	●	●	●	-
K	-	●	●	●	●
N	●	○	-	●	○
S	-	○	-	-	-
H	-	-	-	-	-

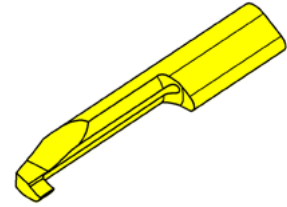
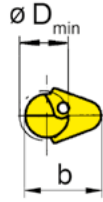
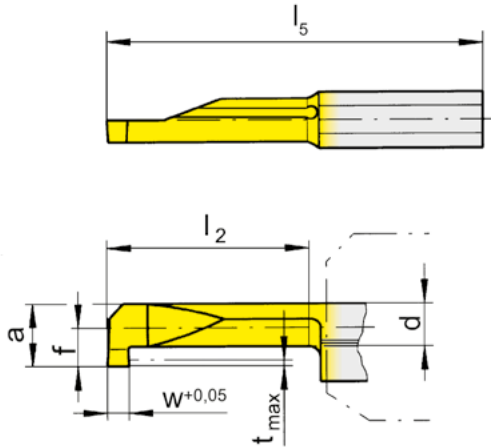
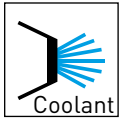
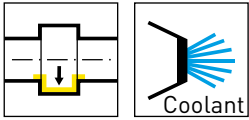

Coating grades

R = right hand version shown

L = left hand version

▲ In stock

Δ 2 weeks

Part number	w	f	a	d	b	l ₂	l ₅	t _{max}	D _{min}	HIS	MG12	IG35	TH35	TI25	TN35
RU105.0031.1.7	.031	.157	.252	.146	.276	.394	.984	.098	.268	105125	▲	▲	▲		▲
RU105.0031.2.7	.031	.157	.252	.146	.276	.591	1.181	.098	.268	105125	▲	▲	▲		▲
RU105.0031.3.7	.031	.157	.252	.146	.276	.787	1.378	.098	.268	105125	▲	▲	▲		▲
RU105.0031.4.7	.031	.157	.252	.146	.276	.984	1.575	.098	.268	105125		▲	▲		▲
RU105.0031.5.7	.031	.157	.252	.146	.276	1.181	1.772	.098	.268	105125		▲	▲		▲
RU105.0046.1.7	.046	.157	.252	.146	.276	.394	.984	.098	.268	105125		▲	▲	Δ	▲
RU105.0046.2.7	.046	.157	.252	.146	.276	.591	1.181	.098	.268	105125		▲	▲		▲
RU105.0046.3.7	.046	.157	.252	.146	.276	.787	1.378	.098	.268	105125		▲	▲		▲
RU105.0046.4.7	.046	.157	.252	.146	.276	.984	1.575	.098	.268	105125		▲	▲		▲
RU105.0046.5.7	.046	.157	.252	.146	.276	1.181	1.772	.098	.268	105125		▲	▲		▲
LU105.0031.1.7	.031	.157	.252	.146	.276	.394	.984	.098	.268	105125		▲			▲
LU105.0031.2.7	.031	.157	.252	.146	.276	.591	1.181	.098	.268	105125		▲			▲
LU105.0031.3.7	.031	.157	.252	.146	.276	.787	1.378	.098	.268	105125					▲
LU105.0031.4.7	.031	.157	.252	.146	.276	.984	1.575	.098	.268	105125			▲		▲
LU105.0046.1.7	.046	.157	.252	.146	.276	.394	.984	.098	.268	105125		▲			▲
LU105.0046.2.7	.046	.157	.252	.146	.276	.591	1.181	.098	.268	105125		▲			▲
LU105.0046.3.7	.046	.157	.252	.146	.276	.787	1.378	.098	.268	105125		▲			▲
LU105.0046.4.7	.046	.157	.252	.146	.276	.984	1.575	.098	.268	105125			▲		Δ
LU105.0046.5.7	.046	.157	.252	.146	.276	1.181	1.772	.098	.268	105125		▲			▲

Dimensions in inch



P	-	●	●	●	●
M	-	●	●	●	-
K	-	●	●	●	●
N	●	○	-	●	○
S	-	○	-	-	-
H	-	-	-	-	-

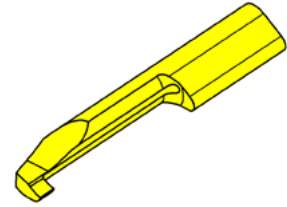
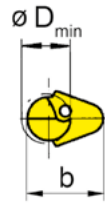
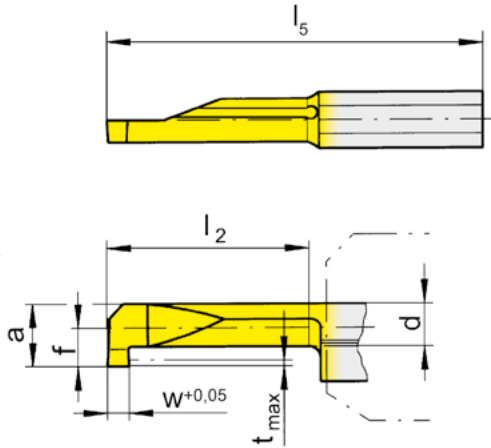
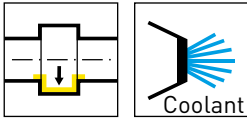

Coating grades

R = right hand version shown

L = left hand version

▲ In stock

Δ 2 weeks

Part number	w	f	a	d	b	l ₂	l ₅	t _{max}	D _{min}	HIS	MG12	IG35	TH35	TN35
RU105.0062.1.7	.062	.157	.252	.146	.276	.394	.984	.098	.268	105125		▲	▲	▲
RU105.0062.2.7	.062	.157	.252	.146	.276	.591	1.181	.098	.268	105125		▲	▲	▲
RU105.0062.3.7	.062	.157	.252	.146	.276	.787	1.378	.098	.268	105125	▲	▲	▲	▲
RU105.0062.4.7	.062	.157	.252	.146	.276	.984	1.575	.098	.268	105125		▲	▲	▲
RU105.0062.5.7	.062	.157	.252	.146	.276	1.181	1.772	.098	.268	105125		▲	▲	▲
RU105.0078.1.7	.078	.157	.252	.146	.276	.394	.984	.098	.268	105125	▲	▲	▲	▲
RU105.0078.2.7	.078	.157	.252	.146	.276	.591	1.181	.098	.268	105125	▲	▲	▲	▲
RU105.0078.3.7	.078	.157	.252	.146	.276	.787	1.378	.098	.268	105125		▲	▲	▲
RU105.0078.4.7	.078	.157	.252	.146	.276	.984	1.575	.098	.268	105125		▲	▲	▲
RU105.0078.5.7	.078	.157	.252	.146	.276	1.181	1.772	.098	.268	105125		▲	▲	Δ
LU105.0062.1.7	.062	.157	.252	.146	.276	.394	.984	.098	.268	105125		▲		▲
LU105.0062.2.7	.062	.157	.252	.146	.276	.591	1.181	.098	.268	105125		▲	Δ	▲
LU105.0062.3.7	.062	.157	.252	.146	.276	.787	1.378	.098	.268	105125		▲		▲
LU105.0062.4.7	.062	.157	.252	.146	.276	.984	1.575	.098	.268	105125		▲		▲
LU105.0062.5.7	.062	.157	.252	.146	.276	1.181	1.772	.098	.268	105125		▲		▲
LU105.0078.1.7	.078	.157	.252	.146	.276	.394	.984	.098	.268	105125		▲		▲
LU105.0078.2.7	.078	.157	.252	.146	.276	.591	1.181	.098	.268	105125		▲		▲
LU105.0078.3.7	.078	.157	.252	.146	.276	.787	1.378	.098	.268	105125		▲		▲
LU105.0078.4.7	.078	.157	.252	.146	.276	.984	1.575	.098	.268	105125		▲		▲
LU105.0078.5.7	.078	.157	.252	.146	.276	1.181	1.772	.098	.268	105125				Δ

Dimensions in inch



P	-	●	●	●
M	-	●	●	-
K	-	●	●	●
N	●	○	-	○
S	-	○	-	-
H	-	-	-	-

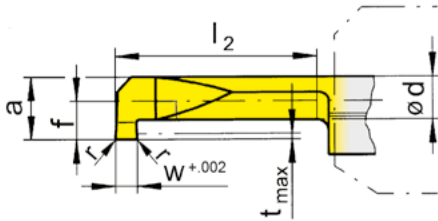
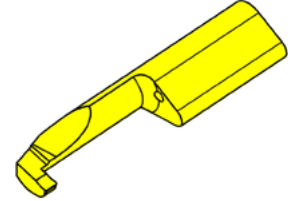
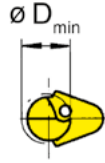
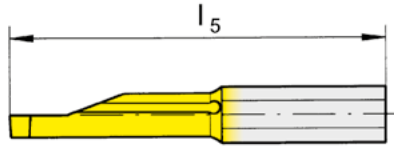
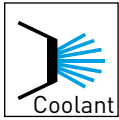
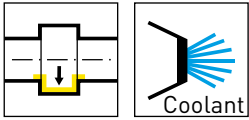

Coating grades

R = right hand version shown

L = left hand version

▲ In stock

△ 2 weeks

Part number	w	r	f	a	d	l ₂	l ₅	t _{max}	D _{min}	HIS	IG35	TH35	TN35
RU105.4604.1.5	.046	.004	.091	.185	.138	.394	.984	.039	.197	105125	▲	▲	▲
RU105.4604.3.5	.046	.004	.091	.185	.138	.787	1.378	.039	.197	105125	▲	▲	▲
RU105.4604.5.5	.046	.004	.091	.185	.138	1.181	1.772	.039	.197	105125		▲	
RU105.6204.1.5	.062	.004	.091	.185	.138	.394	.984	.039	.197	105125	▲	▲	▲
RU105.6204.3.5	.062	.004	.091	.185	.138	.787	1.378	.039	.197	105125	▲	▲	▲
RU105.6204.5.5	.062	.004	.091	.185	.138	1.181	1.772	.039	.197	105125	▲	▲	▲
RU105.7804.1.5	.078	.004	.091	.185	.138	.394	.984	.039	.197	105125		△	△
RU105.7804.3.5	.078	.004	.091	.185	.138	.787	1.378	.039	.197	105125	▲	△	▲
RU105.7804.5.5	.078	.004	.091	.185	.138	1.181	1.772	.039	.197	105125	▲	△	▲
LU105.4604.3.5	.046	.004	.091	.185	.138	.787	1.378	.039	.197	105125	▲		▲

Dimensions in inch



P	●	●	●
M	●	●	-
K	●	●	●
N	○	-	○
S	○	-	-
H	-	-	-

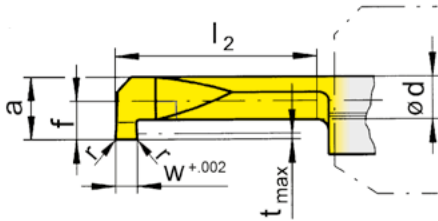
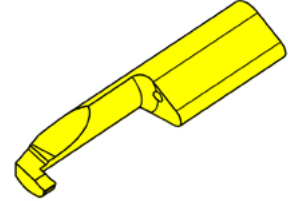
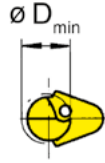
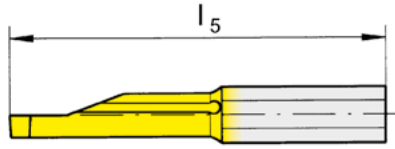
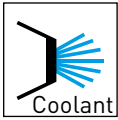
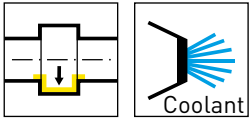

Coating grades

R = right hand version shown

L = left hand version

▲ In stock

Δ 2 weeks

Part number	w	r	f	a	d	l ₂	l ₅	t _{max}	D _{min}	HIS	IG35	TH35	TN35
RU105.4604.1.6	.046	.004	.130	.224	.146	.394	.984	.071	.236	105125	▲	▲	▲
RU105.4604.3.6	.046	.004	.130	.224	.146	.787	1.378	.071	.236	105125	▲	▲	▲
RU105.4604.5.6	.046	.004	.130	.224	.146	1.181	1.772	.071	.236	105125	▲	▲	▲
RU105.6204.1.6	.062	.004	.130	.224	.146	.394	.984	.071	.236	105125	▲	▲	▲
RU105.6204.3.6	.062	.004	.130	.224	.146	.787	1.378	.071	.236	105125	▲	▲	▲
RU105.6204.5.6	.062	.004	.130	.224	.146	1.181	1.772	.071	.236	105125	▲	▲	▲
RU105.7804.1.6	.078	.004	.130	.224	.146	.394	.984	.071	.236	105125	▲	▲	▲
RU105.7804.3.6	.078	.004	.130	.224	.146	.787	1.378	.071	.236	105125	▲	▲	▲
RU105.7804.5.6	.078	.004	.130	.224	.146	1.181	1.772	.071	.236	105125	▲	▲	▲
RU105.7808.5.6	.078	.008	.130	.224	.146	1.181	1.772	.071	.236	105125	▲	▲	▲
LU105.4604.1.6	.046	.004	.130	.224	.146	.394	.984	.071	.236	105125	▲		▲
LU105.7804.3.6	.078	.004	.130	.224	.146	.787	1.378	.071	.236	105125			Δ

Dimensions in inch



P	●	●	●
M	●	●	-
K	●	●	●
N	o	-	o
S	o	-	-
H	-	-	-

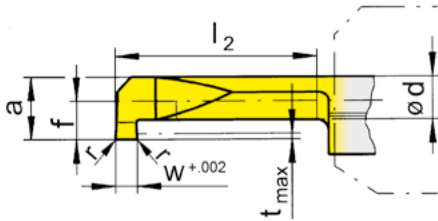
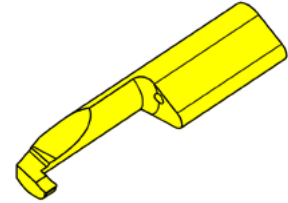
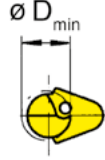
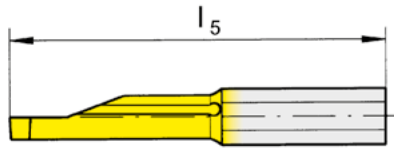
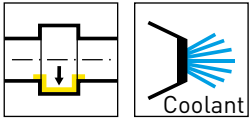

Coating grades

R = right hand version shown

L = left hand version

▲ In stock

Δ 2 weeks

Part number	w	r	f	a	d	l ₂	l ₅	t _{max}	D _{min}	HIS		MG12	IG35	TH35	TN35
RU105.4604.1.7	.046	.004	.157	.252	.146	.394	.984	.098	.268	105125			▲	▲	Δ
RU105.4604.2.7	.046	.004	.157	.252	.146	.591	1.181	.098	.268	105125			▲	▲	▲
RU105.4604.3.7	.046	.004	.157	.252	.146	.787	1.378	.098	.268	105125		▲	▲	▲	▲
RU105.4604.4.7	.046	.004	.157	.252	.146	.984	1.575	.098	.268	105125			▲	▲	▲
RU105.4604.5.7	.046	.004	.157	.252	.146	1.181	1.772	.098	.268	105125			▲	▲	▲
RU105.4608.1.7	.046	.008	.157	.252	.146	.394	.984	.098	.268	105125			▲	▲	▲
RU105.4608.2.7	.046	.008	.157	.252	.146	.591	1.181	.098	.268	105125			▲	▲	▲
RU105.4608.3.7	.046	.008	.157	.252	.146	.787	1.378	.098	.268	105125			▲	▲	▲
RU105.4608.4.7	.046	.008	.157	.252	.146	.984	1.575	.098	.268	105125			▲	▲	▲
RU105.4608.5.7	.046	.008	.157	.252	.146	1.181	1.772	.098	.268	105125			▲	▲	▲
LU105.4604.3.7	.046	.004	.157	.252	.146	.787	1.378	.098	.268	105125			▲	▲	▲

Dimensions in inch



P	-	●	●	●
M	-	●	●	-
K	-	●	●	●
N	●	○	-	○
S	-	○	-	-
H	-	-	-	-

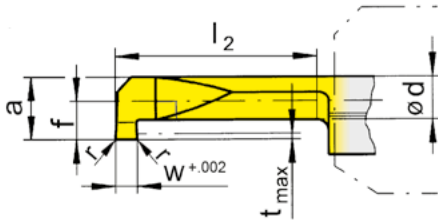
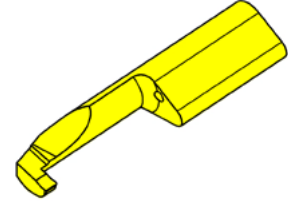
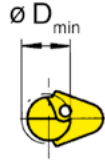
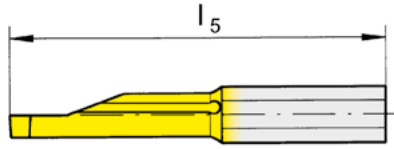
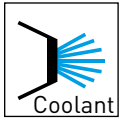
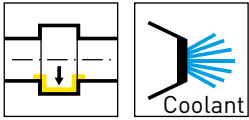

Coating grades

R = right hand version shown

L = left hand version

▲ In stock

Δ 2 weeks

Part number	w	r	f	a	d	l ₂	l ₅	t _{max}	D _{min}	HIS		MG12	IG35	TH35	TN35
RU105.6204.1.7	.062	.004	.157	.252	.146	.394	.984	.098	.268	105125			▲	▲	▲
RU105.6204.2.7	.062	.004	.157	.252	.146	.591	1.181	.098	.268	105125			▲	▲	▲
RU105.6204.3.7	.062	.004	.157	.252	.146	.787	1.378	.098	.268	105125	▲		▲	▲	▲
RU105.6204.4.7	.062	.004	.157	.252	.146	.984	1.575	.098	.268	105125			▲	▲	▲
RU105.6208.1.7	.062	.008	.157	.252	.146	.394	.984	.098	.268	105125			▲	▲	▲
RU105.6208.2.7	.062	.008	.157	.252	.146	.591	1.181	.098	.268	105125			▲	▲	▲
RU105.6208.3.7	.062	.008	.157	.252	.146	.787	1.378	.098	.268	105125			▲	▲	▲
RU105.6208.4.7	.062	.008	.157	.252	.146	.984	1.575	.098	.268	105125			▲	▲	▲
RU105.6208.5.7	.062	.008	.157	.252	.146	1.181	1.772	.098	.268	105125			▲	▲	▲
LU105.6204.1.7	.062	.004	.157	.252	.146	.394	.984	.098	.268	105125					Δ
LU105.6208.1.7	.062	.008	.157	.252	.146	.394	.984	.098	.268	105125					▲

Dimensions in inch



P	-	●	●	●
M	-	●	●	-
K	-	●	●	●
N	●	○	-	○
S	-	○	-	-
H	-	-	-	-

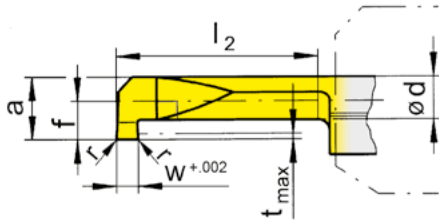
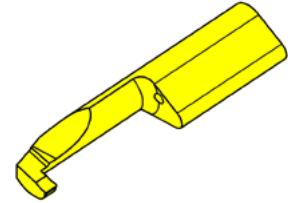
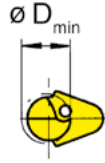
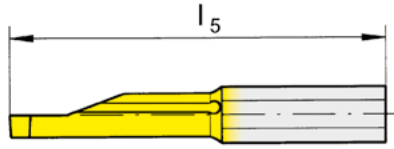
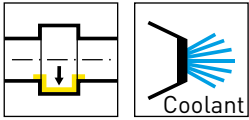

Coating grades

R = right hand version shown

L = left hand version

▲ In stock

Δ 2 weeks

Part number	w	r	f	a	d	l ₂	l ₅	t _{max}	D _{min}	HIS	IG35	TH35	TN35
RU105.7804.1.7	.078	.004	.157	.252	.146	.394	.984	.098	.268	105125	▲	▲	▲
RU105.7804.2.7	.078	.004	.157	.252	.146	.591	1.181	.098	.268	105125	▲	▲	▲
RU105.7804.3.7	.078	.004	.157	.252	.146	.787	1.378	.098	.268	105125	▲	▲	▲
RU105.7804.4.7	.078	.004	.157	.252	.146	.984	1.575	.098	.268	105125	▲	▲	▲
RU105.7804.5.7	.078	.004	.157	.252	.146	1.181	1.772	.098	.268	105125	▲	▲	▲
RU105.7808.1.7	.078	.008	.157	.252	.146	.394	.984	.098	.268	105125	▲	▲	▲
RU105.7808.2.7	.078	.008	.157	.252	.146	.591	1.181	.098	.268	105125	▲	▲	▲
RU105.7808.3.7	.078	.008	.157	.252	.146	.787	1.378	.098	.268	105125	▲	▲	▲
RU105.7808.4.7	.078	.008	.157	.252	.146	.984	1.575	.098	.268	105125	▲	▲	▲
RU105.7808.5.7	.078	.008	.157	.252	.146	1.181	1.772	.098	.268	105125	▲	▲	▲
LU105.7804.3.7	.078	.004	.157	.252	.146	.787	1.378	.098	.268	105125	▲	▲	▲

Dimensions in inch



P	●	●	●
M	●	●	-
K	●	●	●
N	o	-	o
S	o	-	-
H	-	-	-

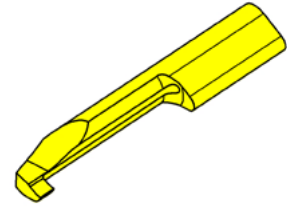
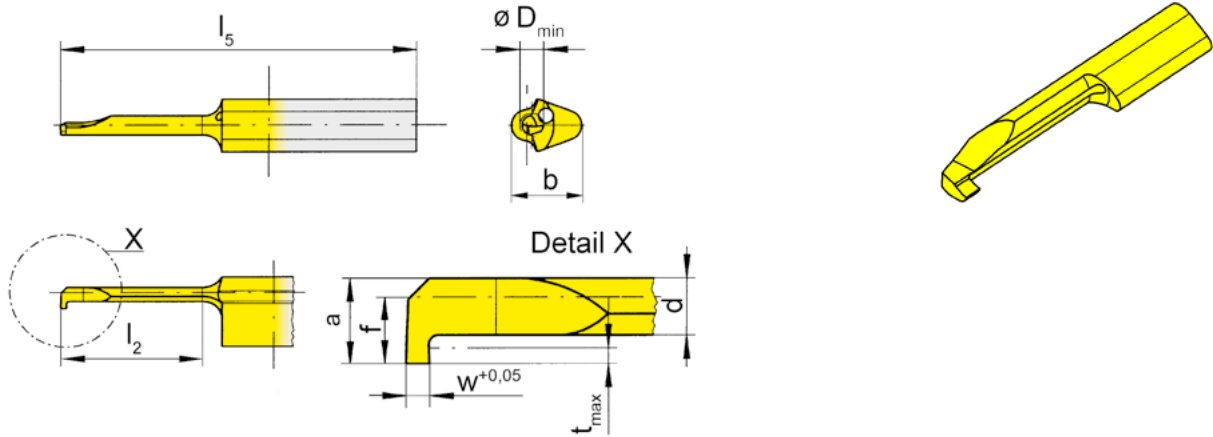
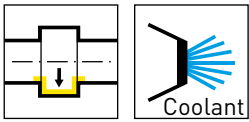

Coating grades

R = right hand version shown

L = left hand version

▲ In stock

Δ 2 weeks

Part number	w	f	a	d	b	l_2	l_5	t_{max}	D_{min}	HIS	EG35	IG35	TI25	
R105.0050.0.2	0.5	1.4	1.8	1.2	5.9	6	25	0.4	2	105123	▲	▲	▲	
R105.0050.1.2	0.5	1.4	1.8	1.2	5.9	9	25	0.4	2	105123	▲	▲	▲	
L105.0050.0.2	0.5	1.4	1.8	1.2	5.9	6	25	0.4	2	105123	▲		▲	
L105.0050.1.2	0.5	1.4	1.8	1.2	5.9	9	25	0.4	2	105123	Δ		▲	
											P	●	●	●
											M	●	●	●
											K	●	●	-
											N	○	○	●
											S	-	○	-
											H	-	-	-

Dimensions in mm

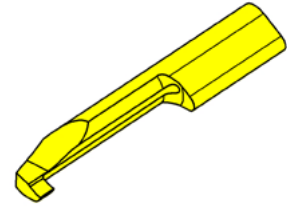
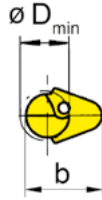
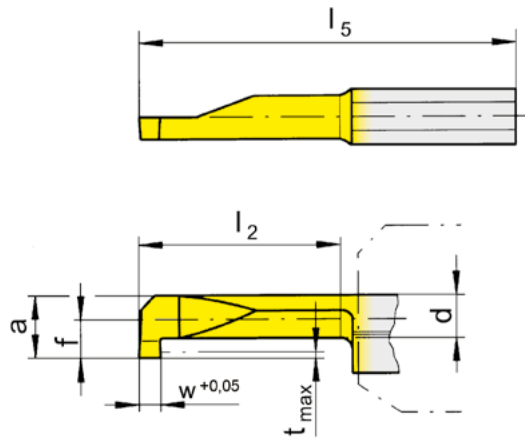
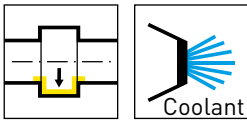

Coating grades

R = right hand version shown

L = left hand version

▲ In stock

Δ 2 weeks

Part number	w	f	a	d	b	l ₂	l ₅	t _{max}	D _{min}	HIS	Coating grades					
											EG35	ES15	IG35	TI25		
R105.0050.1.3	0.5	1.4	2.7	2	5.9	8	25	0.5	3	105123	Δ	▲				
R105.0050.2.3	0.5	1.4	2.7	2	5.9	12	30	0.5	3	105123	Δ	▲	▲			
R105.0050.3.3	0.5	1.4	2.7	2	5.9	16	35	0.5	3	105123	Δ	▲				
R105.0070.1.3	0.7	1.4	2.7	1.9	5.9	8	25	0.6	3	105123	▲		▲	▲		
R105.0070.2.3	0.7	1.4	2.7	1.9	5.9	12	30	0.6	3	105123	▲		▲	▲		
R105.0070.3.3	0.7	1.4	2.7	1.9	5.9	16	35	0.6	3	105123	▲		▲	▲		
L105.0070.1.3	0.7	1.4	2.7	1.9	5.9	8	25	0.6	3	105123	▲			▲		
L105.0070.2.3	0.7	1.4	2.7	1.9	5.9	12	30	0.6	3	105123	Δ			▲		
L105.0070.3.3	0.7	1.4	2.7	1.9	5.9	16	35	0.6	3	105123	Δ			▲		
Dimensions in mm												P	●	●	●	●
												M	●	●	●	●
												K	●	-	●	-
												N	○	●	○	●
												S	-	○	○	-
												H	-	-	-	-

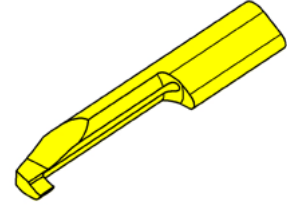
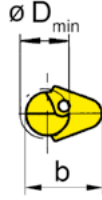
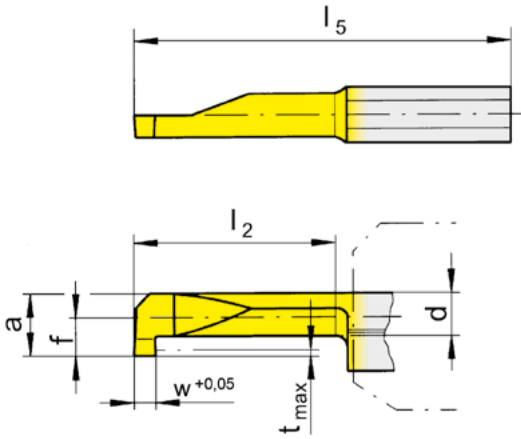
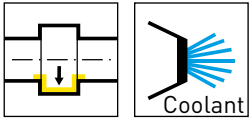

Coating grades

R = right hand version shown

L = left hand version

▲ In stock

Δ 2 weeks

Part number	w	f	a	d	b	l ₂	l ₅	t _{max}	D _{min}	HIS	EG35	ES15	IG35	TN35
R105.0050.1.4	0.5	1.9	3.7	2.9	6.4	10	25	0.6	4	105124	Δ	▲	▲	
R105.0050.2.4	0.5	1.9	3.7	2.9	6.4	15	30	0.6	4	105124	Δ	▲		
R105.0050.3.4	0.5	1.9	3.7	2.9	6.4	20	35	0.6	4	105124	Δ	▲		
R105.0100.1.4	1	1.9	3.7	2.7	6.4	10	25	0.8	4	105124	▲		▲	▲
R105.0100.2.4	1	1.9	3.7	2.7	6.4	15	30	0.8	4	105124	▲		▲	▲
R105.0100.3.4	1	1.9	3.7	2.7	6.4	20	35	0.8	4	105124	Δ		▲	▲
L105.0100.1.4	1	1.9	3.7	2.7	6.4	10	25	0.8	4	105124	Δ		▲	▲
L105.0100.2.4	1	1.9	3.7	2.7	6.4	15	30	0.8	4	105124	Δ		▲	▲
L105.0100.3.4	1	1.9	3.7	2.7	6.4	20	35	0.8	4	105124	Δ		▲	▲

Dimensions in mm

P	●	●	●	●
M	●	●	●	-
K	●	-	●	●
N	○	●	○	○
S	-	○	○	-
H	-	-	-	-

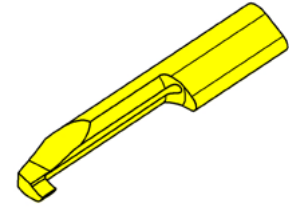
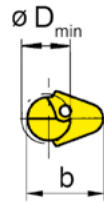
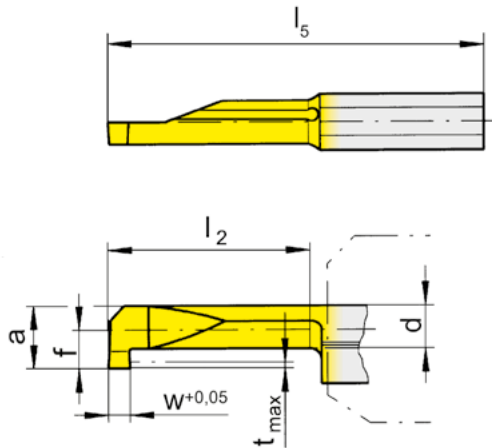
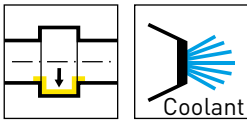

Coating grades

R = right hand version shown

L = left hand version

▲ In stock

△ 2 weeks

Part number	w	f	a	d	b	l ₂	l ₅	t _{max}	D _{min}	HIS	Coating grades			
											EG35	IG35	TH35	TN35
R105.0100.1.5	1	2.3	4.7	3.5	7	10	25	1	5	105125	▲	▲	▲	▲
R105.0100.2.5	1	2.3	4.7	3.5	7	15	30	1	5	105125	▲	▲	▲	▲
R105.0100.3.5	1	2.3	4.7	3.5	7	20	35	1	5	105125	▲		▲	▲
R105.0150.1.5	1.5	2.3	4.7	3.5	7	10	25	1	5	105125	▲		▲	▲
R105.0150.2.5	1.5	2.3	4.7	3.5	7	15	30	1	5	105125	▲	▲	▲	▲
R105.0150.3.5	1.5	2.3	4.7	3.5	7	20	35	1	5	105125	▲		▲	▲
R105.0200.1.5	2	2.3	4.7	3.5	7	10	25	1	5	105125	▲		▲	▲
R105.0200.2.5	2	2.3	4.7	3.5	7	15	30	1	5	105125	▲		▲	▲
R105.0200.3.5	2	2.3	4.7	3.5	7	20	35	1	5	105125	▲	▲	▲	▲
L105.0100.1.5	1	2.3	4.7	3.5	7	10	25	1	5	105125	▲		▲	▲
L105.0100.2.5	1	2.3	4.7	3.5	7	15	30	1	5	105125	△		▲	▲
L105.0100.3.5	1	2.3	4.7	3.5	7	20	35	1	5	105125	△		▲	▲
L105.0150.1.5	1.5	2.3	4.7	3.5	7	10	25	1	5	105125	△		▲	▲
L105.0150.2.5	1.5	2.3	4.7	3.5	7	15	30	1	5	105125	△		▲	▲
L105.0150.3.5	1.5	2.3	4.7	3.5	7	20	35	1	5	105125	△		▲	▲
L105.0200.1.5	2	2.3	4.7	3.5	7	10	25	1	5	105125	△		▲	▲
L105.0200.2.5	2	2.3	4.7	3.5	7	15	30	1	5	105125	△		▲	▲
L105.0200.3.5	2	2.3	4.7	3.5	7	20	35	1	5	105125	△		▲	▲

Dimensions in mm

	P	M	K	N	S	H
EG35	●	●	●	○	-	-
IG35	●	●	●	○	-	-
TH35	●	●	●	○	-	-
TN35	●	●	●	○	-	-

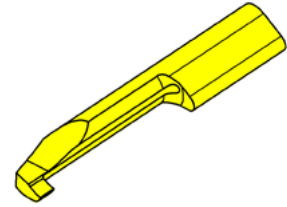
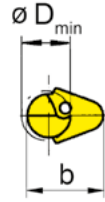
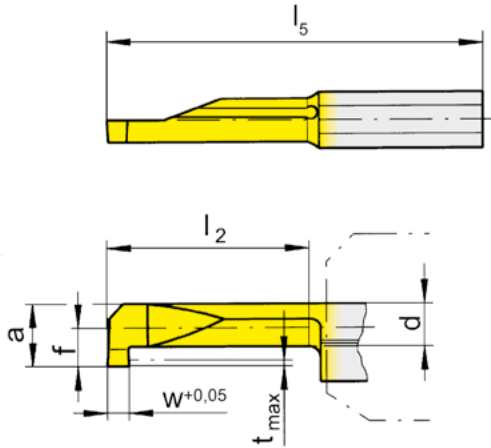
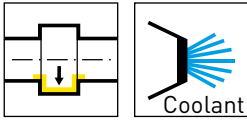

Coating grades

R = right hand version shown

L = left hand version

▲ In stock

Δ 2 weeks

Part number	w	f	a	d	b	l ₂	l ₅	t _{max}	D _{min}	HIS	Coating grades			
											EG35	IG35	TH35	TN35
R105.0100.4.5	1	2.3	4.7	3.5	7	25	40	1	5	105125	▲	▲	▲	▲
R105.0100.5.5	1	2.3	4.7	3.5	7	30	45	1	5	105125	▲		▲	▲
R105.0150.4.5	1.5	2.3	4.7	3.5	7	25	40	1	5	105125			▲	▲
R105.0150.5.5	1.5	2.3	4.7	3.5	7	30	45	1	5	105125	Δ		▲	▲
R105.0200.4.5	2	2.3	4.7	3.5	7	25	40	1	5	105125	▲		▲	▲
R105.0200.5.5	2	2.3	4.7	3.5	7	30	45	1	5	105125	Δ		▲	▲
L105.0100.4.5	1	2.3	4.7	3.5	7	25	40	1	5	105125	Δ		▲	Δ
L105.0100.5.5	1	2.3	4.7	3.5	7	30	45	1	5	105125	Δ		Δ	▲
L105.0150.4.5	1.5	2.3	4.7	3.5	7	25	40	1	5	105125	Δ		▲	▲
L105.0150.5.5	1.5	2.3	4.7	3.5	7	30	45	1	5	105125	Δ		▲	▲
L105.0200.4.5	2	2.3	4.7	3.5	7	25	40	1	5	105125	Δ		▲	▲
L105.0200.5.5	2	2.3	4.7	3.5	7	30	45	1	5	105125	Δ		▲	Δ

Dimensions in mm

P	●	●	●	●
M	●	●	●	-
K	●	●	●	●
N	○	○	-	○
S	-	○	-	-
H	-	-	-	-

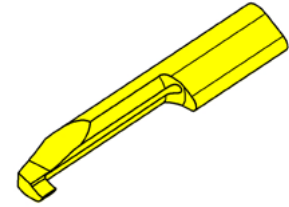
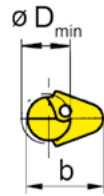
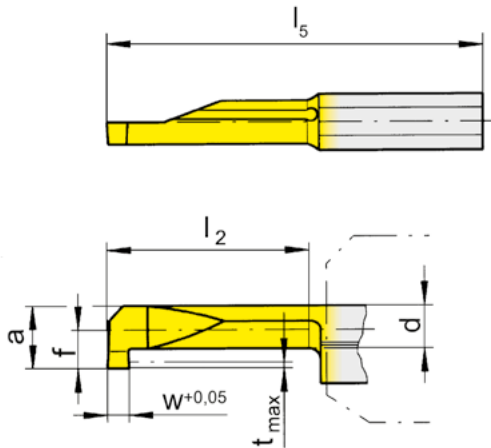
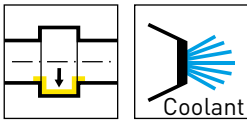

Coating grades

R = right hand version shown

L = left hand version

▲ In stock

△ 2 weeks

Part number	w	f	a	d	b	l ₂	l ₅	t _{max}	D _{min}	HIS	EG35	IG35	TH35	TN35
R105.0100.1.6	1	3.3	5.7	3.7	7	10	25	1.8	6	105125	▲	▲	▲	▲
R105.0100.2.6	1	3.3	5.7	3.7	7	15	30	1.8	6	105125	▲	▲	▲	▲
R105.0100.3.6	1	3.3	5.7	3.7	7	20	35	1	6	105125	▲	▲	▲	▲
R105.0150.1.6	1.5	3.3	5.7	3.7	7	10	25	1.8	6	105125	▲	▲	▲	▲
R105.0150.2.6	1.5	3.3	5.7	3.7	7	15	30	1.8	6	105125	▲	▲	▲	▲
R105.0150.3.6	1.5	3.3	5.7	3.7	7	20	35	1.8	6	105125	▲	▲	▲	▲
R105.0200.1.6	2	3.3	5.7	3.7	7	10	25	1.8	6	105125	▲	▲	▲	▲
R105.0200.2.6	2	3.3	5.7	3.7	7	15	30	1.8	6	105125	▲	▲	▲	▲
R105.0200.3.6	2	3.3	5.7	3.7	7	20	35	1.8	6	105125	▲	▲	▲	▲
L105.0100.1.6	1	3.3	5.7	3.7	7	10	25	1.8	6	105125	▲		▲	▲
L105.0100.2.6	1	3.3	5.7	3.7	7	15	30	1.8	6	105125	△		▲	▲
L105.0100.3.6	1	3.3	5.7	3.7	7	20	35	1	6	105125	△		▲	▲
L105.0150.1.6	1.5	3.3	5.7	3.7	7	10	25	1.8	6	105125	▲		▲	▲
L105.0150.2.6	1.5	3.3	5.7	3.7	7	15	30	1.8	6	105125	▲		▲	▲
L105.0150.3.6	1.5	3.3	5.7	3.7	7	20	35	1.8	6	105125	△		▲	▲
L105.0200.1.6	2	3.3	5.7	3.7	7	10	25	1.8	6	105125			▲	▲
L105.0200.2.6	2	3.3	5.7	3.7	7	15	30	1.8	6	105125	▲		▲	▲
L105.0200.3.6	2	3.3	5.7	3.7	7	20	35	1.8	6	105125	▲		▲	▲

Dimensions in mm

P	●	●	●	●
M	●	●	●	-
K	●	●	●	●
N	○	○	-	○
S	-	○	-	-
H	-	-	-	-

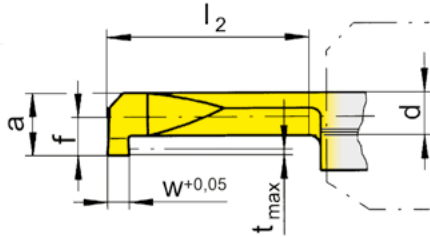
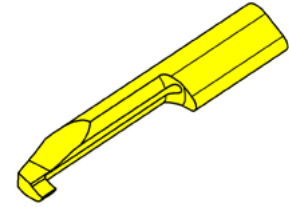
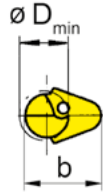
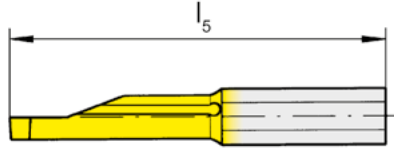
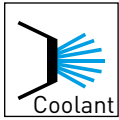
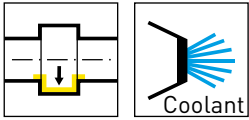

Coating grades

R = right hand version shown

L = left hand version

▲ In stock

△ 2 weeks

Part number	w	f	a	d	b	l ₂	l ₅	t _{max}	D _{min}	HIS	Coating grades			
											EG35	IG35	TH35	TN35
R105.0100.4.6	1	3.3	5.7	3.7	7	25	40	1	6	105125	▲		▲	▲
R105.0100.5.6	1	3.3	5.7	3.7	7	30	45	1.8	6	105125	▲	▲	▲	▲
R105.0150.4.6	1.5	3.3	5.7	3.7	7	25	40	1.8	6	105125	▲		▲	▲
R105.0150.5.6	1.5	3.3	5.7	3.7	7	30	45	1.8	6	105125	▲	▲	▲	▲
R105.0200.4.6	2	3.3	5.7	3.7	7	25	40	1.8	6	105125	▲		▲	▲
R105.0200.5.6	2	3.3	5.7	3.7	7	30	45	1.8	6	105125	▲		▲	▲
L105.0100.4.6	1	3.3	5.7	3.7	7	25	40	1	6	105125	△		▲	△
L105.0100.5.6	1	3.3	5.7	3.7	7	30	45	1.8	6	105125	△		▲	△
L105.0150.4.6	1.5	3.3	5.7	3.7	7	25	40	1.8	6	105125	△		▲	▲
L105.0150.5.6	1.5	3.3	5.7	3.7	7	30	45	1.8	6	105125	△		▲	▲
L105.0200.4.6	2	3.3	5.7	3.7	7	25	40	1.8	6	105125			▲	▲
L105.0200.5.6	2	3.3	5.7	3.7	7	30	45	1.8	6	105125			▲	▲

Dimensions in mm

P	●	●	●	●
M	●	●	●	-
K	●	●	●	●
N	○	○	-	○
S	-	○	-	-
H	-	-	-	-

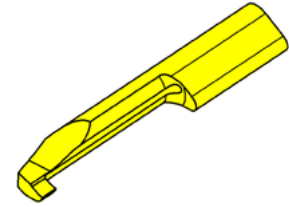
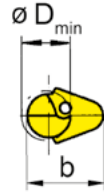
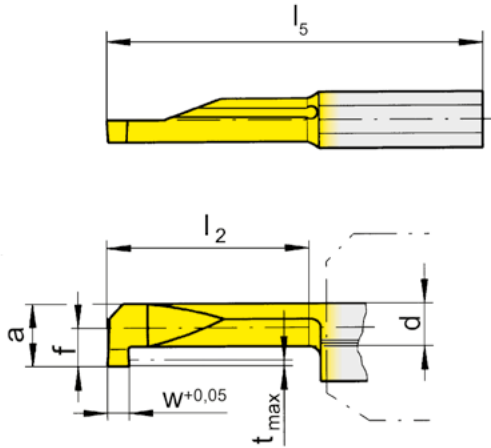
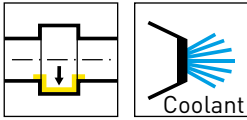

Coating grades

R = right hand version shown

L = left hand version

▲ In stock

△ 2 weeks

Part number	w	f	a	d	b	l ₂	l ₅	t _{max}	D _{min}	HIS	Coating grades			
											EG35	IG35	TH35	TN35
R105.0100.1.7	1	4	6.4	3.7	7	10	25	2.5	6.8	105125	▲	▲	▲	▲
R105.0100.2.7	1	4	6.4	3.7	7	15	30	2.5	6.8	105125	▲		▲	▲
R105.0100.3.7	1	4	6.4	3.7	7	20	35	2.5	6.8	105125	△	▲	▲	▲
R105.0150.1.7	1.5	4	6.4	3.7	7	10	25	2.5	6.8	105125	▲	▲	▲	▲
R105.0150.2.7	1.5	4	6.4	3.7	7	15	30	2.5	6.8	105125	▲	▲	▲	▲
R105.0150.3.7	1.5	4	6.4	3.7	7	20	35	2.5	6.8	105125	▲	▲	▲	▲
R105.0200.1.7	2	4	6.4	3.7	7	10	25	2.5	6.8	105125	▲	▲	▲	▲
R105.0200.2.7	2	4	6.4	3.7	7	15	30	2.5	6.8	105125	▲		▲	▲
R105.0200.3.7	2	4	6.4	3.7	7	20	35	2.5	6.8	105125	▲	▲	▲	▲
L105.0100.1.7	1	4	6.4	3.7	7	10	25	2.5	6.8	105125	▲		▲	▲
L105.0100.2.7	1	4	6.4	3.7	7	15	30	2.5	6.8	105125			▲	▲
L105.0100.3.7	1	4	6.4	3.7	7	20	35	2.5	6.8	105125	▲		▲	▲
L105.0150.1.7	1.5	4	6.4	3.7	7	10	25	2.5	6.8	105125	▲		▲	▲
L105.0150.2.7	1.5	4	6.4	3.7	7	15	30	2.5	6.8	105125			▲	▲
L105.0150.3.7	1.5	4	6.4	3.7	7	20	35	2.5	6.8	105125	▲		▲	▲
L105.0200.1.7	2	4	6.4	3.7	7	10	25	2.5	6.8	105125	▲		▲	▲
L105.0200.2.7	2	4	6.4	3.7	7	15	30	2.5	6.8	105125	△		▲	▲
L105.0200.3.7	2	4	6.4	3.7	7	20	35	2.5	6.8	105125	△		▲	▲

Dimensions in mm

	P	M	K	N	S	H
EG35	●	●	●	○	-	-
IG35	●	●	●	○	-	-
TH35	●	●	●	○	-	-
TN35	●	-	●	○	-	-

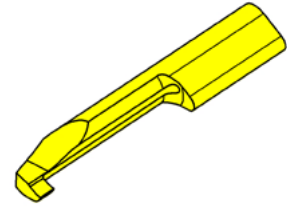
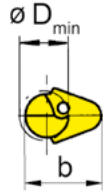
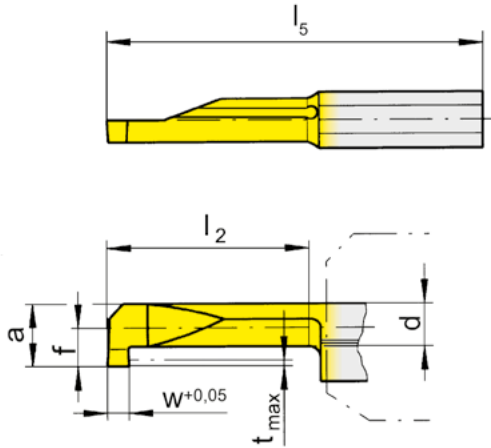
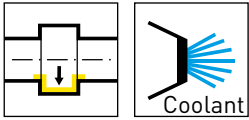

Coating grades

R = right hand version shown

L = left hand version

▲ In stock

Δ 2 weeks

Part number	w	f	a	d	b	l_2	l_5	t_{max}	D_{min}	HIS	EG35	TH35	TN35
R105.0100.4.7	1	4	6.4	3.7	7	25	40	1	6.8	105125	▲	▲	▲
R105.0100.5.7	1	4	6.4	3.7	7	30	45	2.5	6.8	105125	Δ	▲	▲
R105.0150.4.7	1.5	4	6.4	3.7	7	25	40	2.5	6.8	105125	▲	▲	▲
R105.0150.5.7	1.5	4	6.4	3.7	7	30	45	2.5	6.8	105125	▲	▲	▲
R105.0200.4.7	2	4	6.4	3.7	7	25	40	2.5	6.8	105125	▲	▲	▲
R105.0200.5.7	2	4	6.4	3.7	7	30	45	2.5	6.8	105125	Δ	▲	▲
L105.0100.4.7	1	4	6.4	3.7	7	25	40	1	6.8	105125	Δ	▲	▲
L105.0100.5.7	1	4	6.4	3.7	7	30	45	2.5	6.8	105125	Δ	▲	▲
L105.0150.4.7	1.5	4	6.4	3.7	7	25	40	2.5	6.8	105125	Δ	▲	▲
L105.0150.5.7	1.5	4	6.4	3.7	7	30	45	2.5	6.8	105125	Δ	▲	▲
L105.0200.4.7	2	4	6.4	3.7	7	25	40	2.5	6.8	105125	Δ	▲	▲
L105.0200.5.7	2	4	6.4	3.7	7	30	45	2.5	6.8	105125	Δ	▲	▲

Dimensions in mm

P	●	●	●
M	●	●	-
K	●	●	●
N	o	-	o
S	-	-	-
H	-	-	-

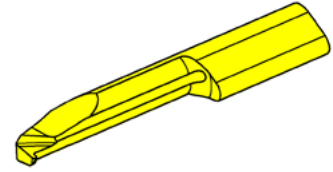
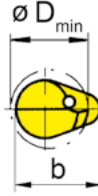
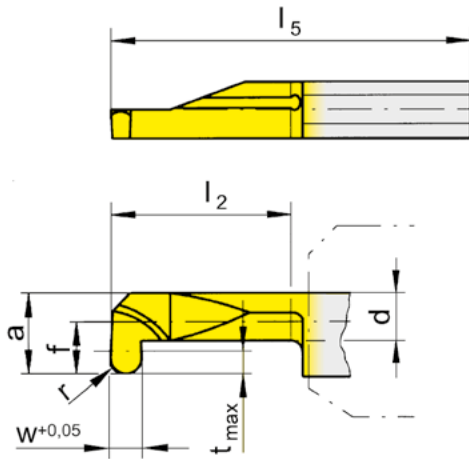
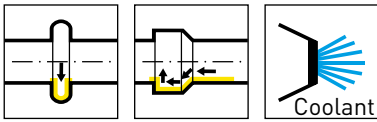

Coating grades

R = right hand version shown

L = left hand version

▲ In stock

Δ 2 weeks

Part number	w	r	f	a	d	b	l_2	l_5	t_{max}	D_{min}	HIS	IG35	TH35	TI25	TN35
RU105.2346.2.4	.046	.023	.075	.146	.106	.252	.591	1.181	.031	.157	105124	▲	▲		▲
RU105.2346.3.5	.046	.023	.091	.185	.138	.276	.787	1.378	.039	.197	105125	▲	▲	Δ	▲
RU105.2346.4.6	.046	.023	.130	.224	.146	.276	.984	1.575	.071	.236	105125	▲	▲		▲
RU105.2346.5.7	.046	.023	.157	.252	.146	.276	1.181	1.772	.098	.268	105125	▲	▲		▲
RU105.3162.3.5	.062	.031	.091	.185	.138	.276	.787	1.378	.039	.197	105125	▲	▲		▲
RU105.3162.4.6	.062	.031	.130	.224	.146	.276	.984	1.575	.071	.236	105125	▲	▲		▲
RU105.3162.5.7	.062	.031	.157	.252	.146	-	1.181	1.772	.098	.268	105125	▲	▲		▲
RU105.3978.3.5	.078	.039	.091	.185	.138	.276	.787	1.378	.039	.197	105125	▲	▲		▲
RU105.3978.4.6	.078	.039	.130	.224	.146	.276	.984	1.575	.071	.236	105125	▲	▲		▲
RU105.3978.5.7	.078	.039	.157	.252	.146	.276	1.181	1.772	.098	.268	105125	▲	▲		▲
LU105.2346.4.6	.046	.023	.130	.224	.146	.276	.984	1.575	.071	.236	105125	▲			▲
LU105.2346.5.7	.046	.023	.157	.252	.146	.276	1.181	1.772	.098	.268	105125	▲			▲
LU105.3162.4.6	.062	.031	.130	.224	.146	.276	.984	1.575	.071	.236	105125				Δ
LU105.3162.5.7	.062	.031	.157	.252	.146	-	1.181	1.772	.098	.268	105125	▲			▲

Dimensions in inch



P	●	●	●	●
M	●	●	●	-
K	●	●	-	●
N	○	-	●	○
S	○	-	-	-
H	-	-	-	-

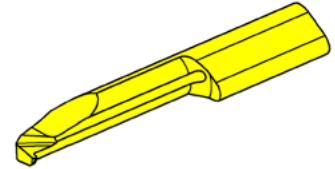
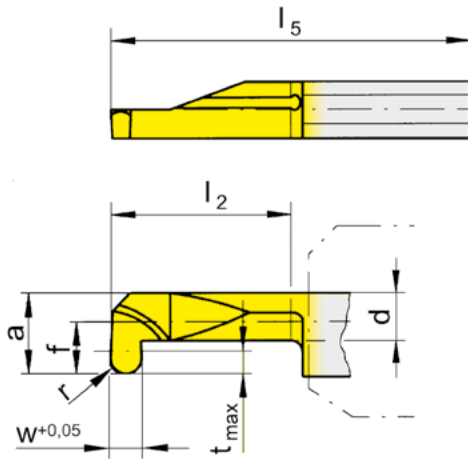
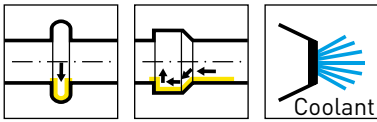

Coating grades

R = right hand version shown

L = left hand version

▲ In stock

△ 2 weeks

Part number	w	r	f	a	d	b	l ₂	l ₅	t _{max}	D _{min}	HIS	Coating grades						
												EG35	ES15	IG35	TF45	TH35	TN35	
R105.0025.2.3	0.5	0.25	1.4	2.7	1.9	5.9	15	30	0.6	3	105123	△	▲					
R105.0005.1.4	1	0.5	1.9	3.7	2.7	6.4	10	25	0.8	4	105124	▲				▲		
R105.0005.2.4	1	0.5	1.9	3.7	2.7	6.4	15	30	0.8	4	105124	▲		▲			▲	
R105.0025.3.5	0.5	0.25	2.3	4.7	3.9	7	20	35	0.6	5	105125	△	▲					
R105.0005.3.5	1	0.5	2.3	4.7	3.5	7	20	35	1	5	105125	▲		▲	▲		▲	
R105.0007.1.5	1.5	0.75	2.3	4.7	3.5	7	10	25	1	5	105125	△				▲		
R105.0007.3.5	1.5	0.75	2.3	4.7	3.5	7	20	35	1	5	105125	▲				▲	▲	
R105.0010.1.5	2	1	2.3	4.7	3.5	7	10	25	1	5	105125	▲				▲		
R105.0010.3.5	2	1	2.3	4.7	3.5	7	20	35	1	5	105125	▲				▲	▲	
L105.0005.1.4	1	0.5	1.9	3.7	2.7	6.4	10	25	0.8	4	105124	△				▲		
L105.0005.2.4	1	0.5	1.9	3.7	2.7	6.4	15	30	0.8	4	105124	▲				▲	▲	
L105.0005.3.5	1	0.5	2.3	4.7	3.5	7	20	35	1	5	105125	▲				▲	▲	
L105.0007.1.5	1.5	0.75	2.3	4.7	3.5	7	10	25	1	5	105125	△				△		
L105.0007.3.5	1.5	0.75	2.3	4.7	3.5	7	20	35	1	5	105125	△				▲		
L105.0010.1.5	2	1	2.3	4.7	3.5	7	10	25	1	5	105125	△				△		
L105.0010.3.5	2	1	2.3	4.7	3.5	7	20	35	1	5	105125	△				▲	▲	
												P	●	●	●	-	●	●
												M	●	●	●	-	●	-
												K	●	-	●	-	●	●
												N	○	●	○	-	-	○
												S	-	○	○	-	-	-
												H	-	-	-	-	-	-

Dimensions in mm

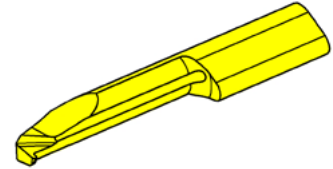
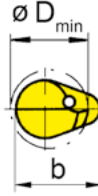
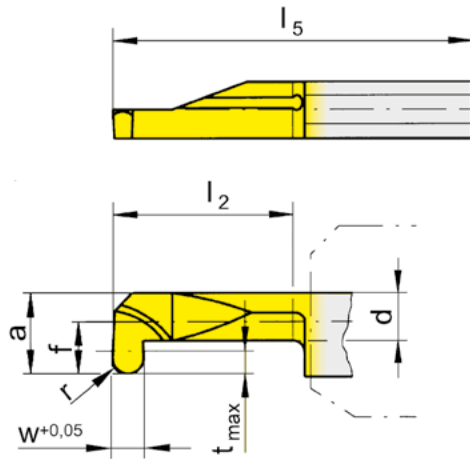
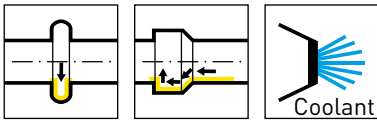

Coating grades

R = right hand version shown

L = left hand version

▲ In stock

△ 2 weeks

Part number	w	r	f	a	d	b	l_2	l_5	t_{max}	D_{min}	HIS	EG35	IG35	TH35	TN35
R105.0005.2.6	1	0.5	3.3	5.7	3.7	7	15	30	1.8	6	105125	▲		▲	
R105.0005.4.6	1	0.5	3.3	5.7	3.7	7	25	40	1.8	6	105125	▲	▲		▲
R105.0007.2.6	1.5	0.75	3.3	5.7	3.7	7	15	30	1.8	6	105125	▲		▲	
R105.0007.4.6	1.5	0.75	3.3	5.7	3.7	7	25	40	1.8	6	105125	▲		▲	▲
R105.0010.2.6	2	1	3.3	5.7	3.7	7	15	30	1.8	6	105125	▲	▲	▲	
R105.0010.4.6	2	1	3.3	5.7	3.7	7	25	40	1.8	6	105125	▲		▲	▲
L105.0005.2.6	1	0.5	3.3	5.7	3.7	7	15	30	1.8	6	105125	△		▲	
L105.0005.4.6	1	0.5	3.3	5.7	3.7	7	25	40	1.8	6	105125	△			▲
L105.0007.2.6	1.5	0.75	3.3	5.7	3.7	7	15	30	1.8	6	105125	△		△	
L105.0007.4.6	1.5	0.75	3.3	5.7	3.7	7	25	40	1.8	6	105125	△			▲
L105.0010.2.6	2	1	3.3	5.7	3.7	7	15	30	1.8	6	105125	△		△	
L105.0010.4.6	2	1	3.3	5.7	3.7	7	25	40	1.8	6	105125				▲

Dimensions in mm

P	●	●	●	●
M	●	●	●	-
K	●	●	●	●
N	○	○	-	○
S	-	○	-	-
H	-	-	-	-

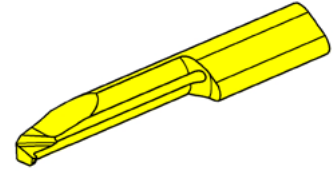
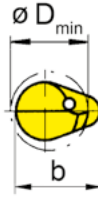
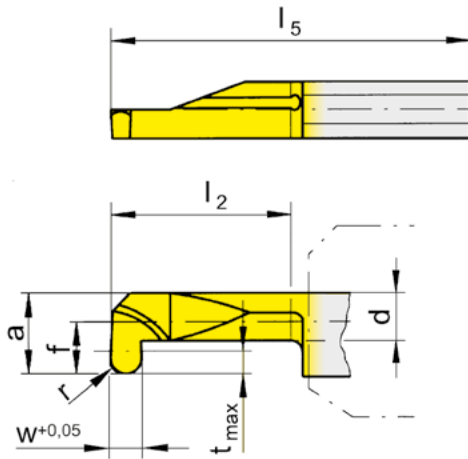
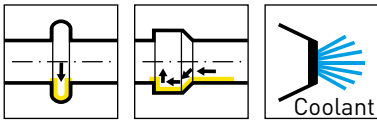

Coating grades

R = right hand version shown

L = left hand version

▲ In stock

Δ 2 weeks

Part number	w	r	f	a	d	b	l ₂	l ₅	t _{max}	D _{min}	HIS	EG35	IG35	TH35	TN35
R105.0005.3.7	1	0.5	4	6.4	3.7	7	20	35	2.5	6.8	105125	▲		▲	
R105.0005.5.7	1	0.5	4	6.4	3.7	7	30	45	2.5	6.8	105125	▲	▲		▲
R105.0007.3.7	1.5	0.75	4	6.4	3.7	7	20	35	2.5	6.8	105125	Δ		▲	
R105.0007.5.7	1.5	0.75	4	6.4	3.7	7	30	45	2.5	7	105125	▲	▲		▲
R105.0010.3.7	2	1	4	6.4	3.7	7	20	35	2.5	6.8	105125	▲		▲	
R105.0010.5.7	2	1	4	6.4	3.7	7	30	45	2.5	6.8	105125	▲			▲
L105.0005.3.7	1	0.5	4	6.4	3.7	7	20	35	2.5	6.8	105125	Δ		▲	
L105.0005.5.7	1	0.5	4	6.4	3.7	7	30	45	2.5	6.8	105125	Δ			▲
L105.0007.3.7	1.5	0.75	4	6.4	3.7	7	20	35	2.5	6.8	105125	Δ		▲	
L105.0007.5.7	1.5	0.75	4	6.4	3.7	7	30	45	2.5	7	105125	Δ			▲
L105.0010.3.7	2	1	4	6.4	3.7	7	20	35	2.5	6.8	105125	Δ		▲	
L105.0010.5.7	2	1	4	6.4	3.7	7	30	45	2.5	6.8	105125	Δ			▲

Dimensions in mm

P	●	●	●	●
M	●	●	●	-
K	●	●	●	●
N	○	○	-	○
S	-	○	-	-
H	-	-	-	-

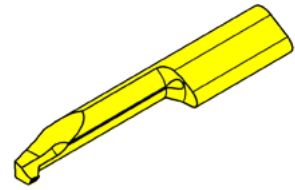
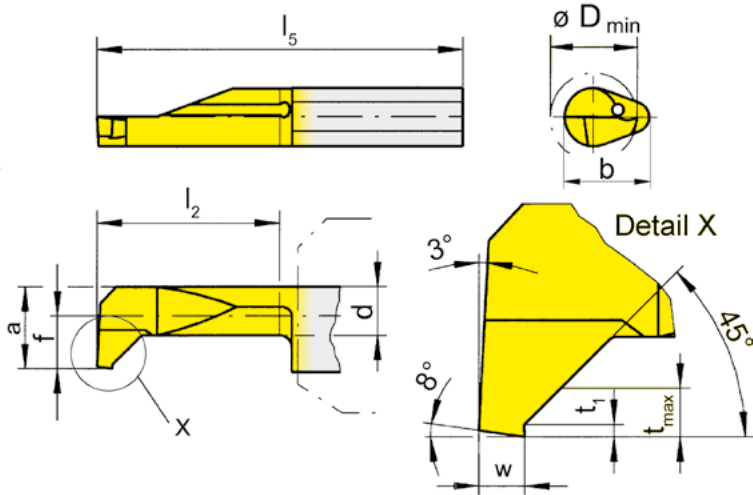
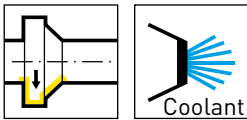

Coating grades

R = right hand version shown

L = left hand version

▲ In stock

△ 2 weeks

Part number	w	f	a	d	b	l ₂	l ₅	t _{max}	t ₁	D _{min}	HIS	EG35	TI25	TN35
R105.0810.1.3	0.7	1.4	2.7	2	5.9	10	25	0.5	0.2	3	105123	▲		▲
R105.0810.2.3	0.7	1.4	2.7	2	5.9	15	30	0.5	0.2	3	105123	△		▲
R105.0810.1.4	1	1.9	3.7	2.7	6.4	10	25	0.7	0.2	4	105124	▲		▲
R105.0810.2.4	1	1.9	3.7	2.7	6.4	15	30	0.7	0.2	4	105124	▲		▲
R105.0810.3.4	1	1.9	3.7	2.7	6.4	20	35	0.7	0.2	4	105124	△		▲
R105.0810.3.5	1	2.3	4.7	3.5	7	20	35	0.7	0.2	5	105125	▲	▲	▲
R105.0810.4.5	1	2.3	4.7	3.5	7	25	40	0.7	0.2	5	105125	▲	▲	▲
R105.0810.5.5	1	2.3	4.7	3.5	7	30	45	0.7	0.2	5	105125	△	▲	▲
R105.0810.5.6	1	3.1	5.5	4.2	7	30	45	1	0.2	6	105125	▲		▲
R105.0810.7.6	1	3.1	5.5	4.2	7	40	55	1	0.2	6	105125	△		▲
L105.0810.1.3	0.7	1.4	2.7	2	5.9	10	25	0.5	0.2	3	105123	△		▲
L105.0810.2.3	0.7	1.4	2.7	2	5.9	15	30	0.5	0.2	3	105123	△		▲
L105.0810.1.4	1	1.9	3.7	2.7	6.4	10	25	0.7	0.2	4	105124	△		▲
L105.0810.2.4	1	1.9	3.7	2.7	6.4	15	30	0.7	0.2	4	105124	△		▲
L105.0810.3.4	1	1.9	3.7	2.7	6.4	20	35	0.7	0.2	4	105124	△		▲
L105.0810.3.5	1	2.3	4.7	3.5	7	20	35	0.7	0.2	5	105125	△	▲	▲
L105.0810.4.5	1	2.3	4.7	3.5	7	25	40	0.7	0.2	5	105125	△	▲	▲
L105.0810.5.5	1	2.3	4.7	3.5	7	30	45	0.7	0.2	5	105125	△	▲	▲
L105.0810.5.6	1	3.1	5.5	4.2	7	30	45	1	0.2	6	105125	△		▲
L105.0810.7.6	1	3.1	5.5	4.2	7	40	55	1	0.2	6	105125	△		▲

Dimensions in mm

P	●	●	●
M	●	●	-
K	●	-	●
N	○	●	○
S	-	-	-
H	-	-	-

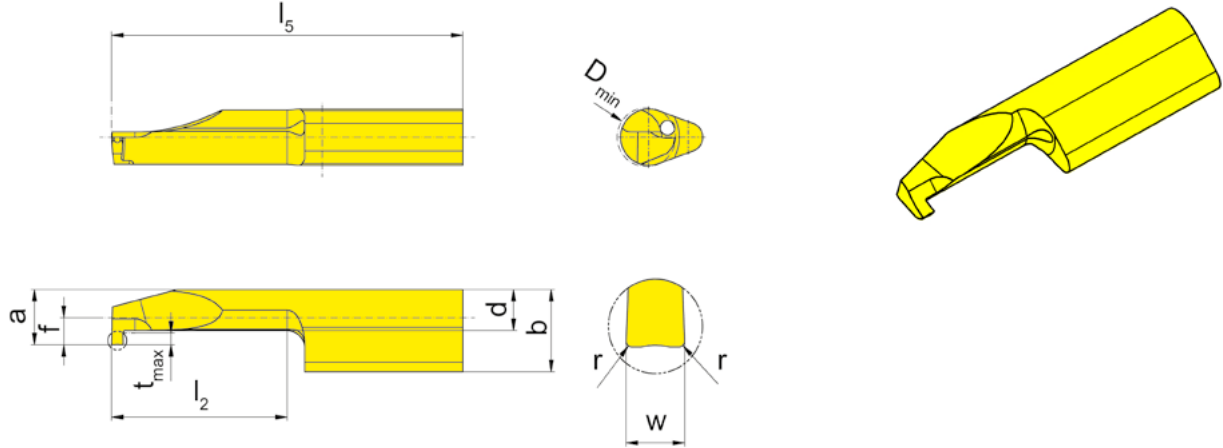

Coating grades

R = right hand version shown

L = left hand version

▲ In stock

Δ 2 weeks

Part number	w	r	f	a	d	b	l ₂	l ₅	t _{max}	D _{min}	HIS	EG35
R105.FB10.1.01	1	0.1	2.3	4.7	3.5	7	10	25	1	5	105125	▲
R105.FB10.2.01	1	0.1	2.3	4.7	3.5	7	15	30	1	5	105125	▲
R105.FB15.1.01	1.5	0.1	2.3	4.7	3.5	7	10	25	1	5	105125	▲
R105.FB15.2.01	1.5	0.1	2.3	4.7	3.5	7	15	30	1	5	105125	▲
L105.FB10.1.01	1	0.1	2.3	4.7	3.5	7	10	25	1	5	105125	▲
L105.FB10.2.01	1	0.1	2.3	4.7	3.5	7	15	30	1	5	105125	▲
L105.FB15.1.01	1.5	0.1	2.3	4.7	3.5	7	10	25	1	5	105125	▲
L105.FB15.2.01	1.5	0.1	2.3	4.7	3.5	7	15	30	1	5	105125	▲

These inserts feature an optimized geometry that produces a fine surface finish

Dimensions in mm

P	●
M	●
K	●
N	○
S	-
H	-

Smallest possible width of groove calculation, w_x

Example insert: R105.FB10.01

$$w_x = 2 \times \text{Width of insert (w)} - 2 \times \text{Insert corner radius (r)}$$

$$w_x = 2 \times 1 \text{ mm} - 2 \times 0.1 \text{ mm}$$

$$w_x = 1.8 \text{ mm}$$

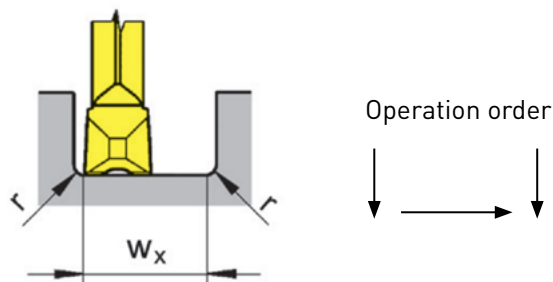

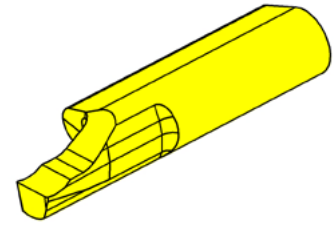
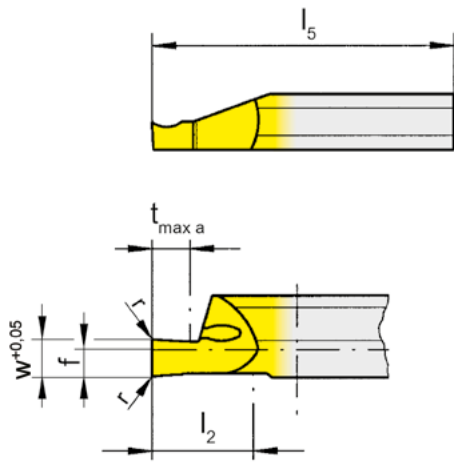
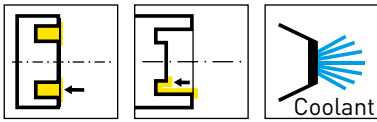

Coating grades

R = right hand version shown

L = left hand version

▲ In stock

Δ 2 weeks

Part number	w	r	f	b	l_2	l_5	$t_{max a}$	$D_{a min}$	HIS	IG35	TH35	TI25
RU105.0812.1.8	.125	.006	.079	.276	.394	.984	.236	.315	105125	▲	▲	▲
RU105.0812.2.8	.125	.006	.079	.276	.591	1.378	.236	.315	105125	▲	▲	▲
RU105.0846.1.8	.046	.006	.079	.276	.394	.984	.098	.315	105125	▲	▲	▲
RU105.0846.2.8	.046	.006	.079	.276	.591	1.378	.098	.315	105125	▲	▲	▲
RU105.0862.1.8	.062	.006	.079	.276	.394	.984	.118	.315	105125	▲	▲	▲
RU105.0862.2.8	.062	.006	.079	.276	.591	1.378	.118	.315	105125	▲	▲	▲
RU105.0878.1.8	.078	.006	.079	.276	.394	.984	.157	.315	105125	▲	▲	▲
RU105.0878.2.8	.078	.006	.079	.276	.591	1.378	.157	.315	105125	▲	▲	▲
RU105.0894.1.8	.094	.006	.079	.276	.394	.984	.197	.315	105125	▲	▲	▲
RU105.0894.2.8	.094	.006	.079	.276	.591	1.378	.197	.315	105125	▲	▲	▲
LU105.0812.1.8	.125	.006	.079	.276	.394	.984	.236	.315	105125	▲		▲
LU105.0812.2.8	.125	.006	.079	.276	.591	1.378	.236	.315	105125	▲		▲
LU105.0846.1.8	.046	.006	.079	.276	.394	.984	.098	.315	105125	▲		▲
LU105.0846.2.8	.046	.006	.079	.276	.591	1.378	.098	.315	105125	▲		▲
LU105.0862.1.8	.062	.006	.079	.276	.394	.984	.118	.315	105125	▲		▲
LU105.0862.2.8	.062	.006	.079	.276	.591	1.378	.118	.315	105125	▲		▲
LU105.0878.1.8	.078	.006	.079	.276	.394	.984	.157	.315	105125	▲		▲
LU105.0878.2.8	.078	.006	.079	.276	.591	1.378	.157	.315	105125	▲		▲
LU105.0894.1.8	.094	.006	.079	.276	.394	.984	.197	.315	105125	▲		▲
LU105.0894.2.8	.094	.006	.079	.276	.591	1.378	.197	.315	105125	▲		▲

Dimensions in inch



P	●	●	●
M	●	●	●
K	●	●	-
N	○	-	●
S	○	-	-
H	-	-	-

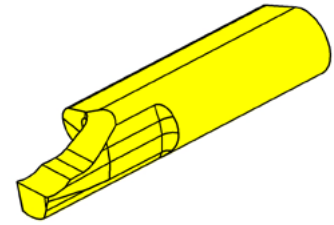
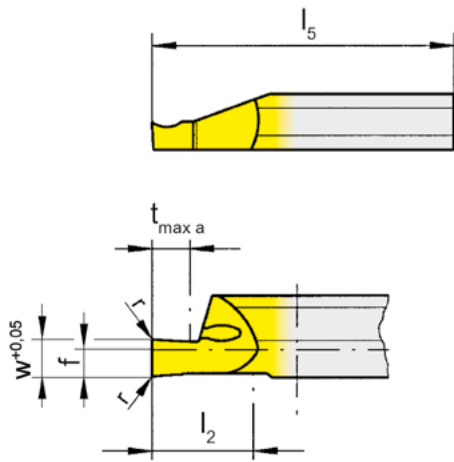
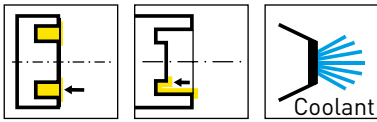

Coating grades

R = right hand version shown

L = left hand version

▲ In stock

Δ 2 weeks

Part number	w	r	f	b	l_2	l_5	$t_{\max a}$	$D_{a \min}$	HIS	EG35	ES15	IG35	TI25
R105.0505.1.8	0.5	-	2	7	10	25	2	5	105125	Δ	▲		
R105.0510.1.8	1	0.05	2	7	10	25	2	5	105125	▲			▲
R105.0510.2.8	1	0.05	2	7	15	35	2	5	105125	▲		▲	▲
R105.0515.1.8	1.5	0.05	2	7	10	25	3	5	105125	▲			▲
R105.0515.2.8	1.5	0.05	2	7	15	35	3	5	105125	▲		▲	▲
R105.0520.1.8	2	0.05	2	7	10	25	5	5	105125	▲			▲
R105.0520.2.8	2	0.05	2	7	15	35	5	5	105125	▲			▲
L105.0510.1.8	1	0.05	2	7	10	25	2	5	105125	▲			▲
L105.0510.2.8	1	0.05	2	7	15	35	2	5	105125	Δ			▲
L105.0515.1.8	1.5	0.05	2	7	10	25	3	5	105125	▲			▲
L105.0515.2.8	1.5	0.05	2	7	15	35	3	5	105125	▲			▲
L105.0520.1.8	2	0.05	2	7	10	25	5	5	105125	▲			▲
L105.0520.2.8	2	0.05	2	7	15	35	5	5	105125	▲			▲

Dimensions in mm

P	●	●	●	●
M	●	●	●	●
K	●	-	●	-
N	○	●	○	●
S	-	○	○	-
H	-	-	-	-

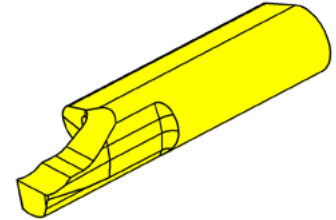
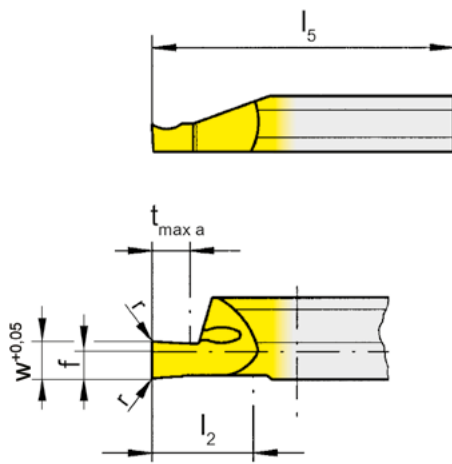
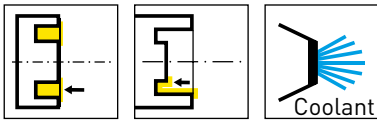

Coating grades

R = right hand version shown

L = left hand version

▲ In stock

Δ 2 weeks

Part number	w	r	f	b	l ₂	l ₅	t _{max a}	D _{a min}	HIS	EG35	IG35	TI25
R105.0610.1.8	1	0.05	2	7	10	25	2	6	105125	▲		▲
R105.0615.1.8	1.5	0.05	2	7	10	25	3	6	105125	▲		▲
R105.0620.1.8	2	0.05	2	7	10	25	5	6	105125	▲	▲	▲
R105.0610.2.8	1	0.05	2	7	15	35	2	6	105125	▲		▲
R105.0615.2.8	1.5	0.05	2	7	15	35	3	6	105125	▲		▲
R105.0620.2.8	2	0.05	2	7	15	35	5	6	105125	▲		▲
L105.0610.1.8	1	0.05	2	7	10	25	2	6	105125	▲		▲
L105.0615.1.8	1.5	0.05	2	7	10	25	3	6	105125	▲		▲
L105.0620.1.8	2	0.05	2	7	10	25	5	6	105125	▲		▲
L105.0610.2.8	1	0.05	2	7	15	35	2	6	105125	Δ		▲
L105.0615.2.8	1.5	0.05	2	7	15	35	3	6	105125	Δ		▲
L105.0620.2.8	2	0.05	2	7	15	35	5	6	105125	▲		▲
P	●	●	●							●	●	●
M	●	●	●							●	●	●
K	●	●	●							●	●	-
N	○	○	○							○	○	○
S	-	-	-							-	-	-
H	-	-	-							-	-	-

Dimensions in mm

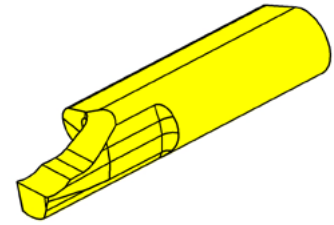
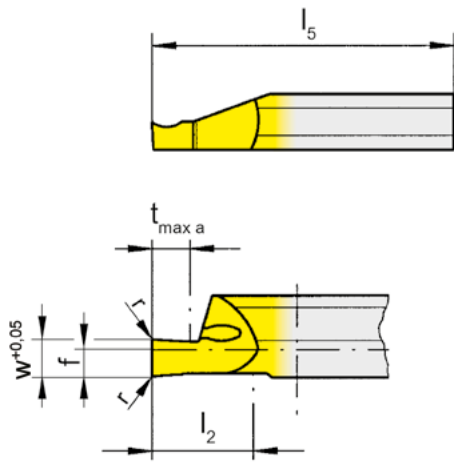
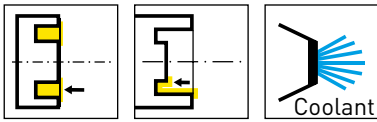

Coating grades

R = right hand version shown

L = left hand version

▲ In stock

△ 2 weeks

Part number	w	r	f	b	l ₂	l ₅	t _{max a}	D _{a min}	HIS	EG35	IG35	TI25
R105.0810.1.8	1	0.15	2	7	10	25	2	8	105125	▲		▲
R105.0815.1.8	1.5	0.15	2	7	10	25	3	8	105125	▲	▲	▲
R105.0820.1.8	2	0.15	2	7	10	25	4	8	105125	▲		▲
R105.0825.1.8	2.5	0.15	2	7	10	25	5	8	105125	▲		▲
R105.0830.1.8	3	0.15	2	7	10	25	6	8	105125	▲	▲	▲
R105.0810.2.8	1	0.15	2	7	15	35	2	8	105125	▲	▲	▲
R105.0815.2.8	1.5	0.15	2	7	15	35	3	8	105125	▲	▲	▲
R105.0820.2.8	2	0.15	2	7	15	35	4	8	105125	▲		▲
R105.0825.2.8	2.5	0.15	2	7	15	35	5	8	105125	▲	▲	▲
R105.0830.2.8	3	0.15	2	7	15	35	6	8	105125	▲	▲	▲
L105.0810.1.8	1	0.15	2	7	10	25	2	8	105125	▲		▲
L105.0815.1.8	1.5	0.15	2	7	10	25	3	8	105125	▲		▲
L105.0820.1.8	2	0.15	2	7	10	25	4	8	105125	▲		▲
L105.0825.1.8	2.5	0.15	2	7	10	25	5	8	105125	▲		▲
L105.0830.1.8	3	0.15	2	7	10	25	6	8	105125	▲	▲	▲
L105.0810.2.8	1	0.15	2	7	15	35	2	8	105125	▲	▲	▲
L105.0815.2.8	1.5	0.15	2	7	15	35	3	8	105125	▲		▲
L105.0820.2.8	2	0.15	2	7	15	35	4	8	105125	▲		▲
L105.0825.2.8	2.5	0.15	2	7	15	35	5	8	105125	▲		▲
L105.0830.2.8	3	0.15	2	7	15	35	6	8	105125	▲		▲

Dimensions in mm

P	●	●	●
M	●	●	●
K	●	●	-
N	○	○	●
S	-	○	-
H	-	-	-

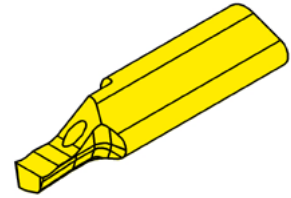
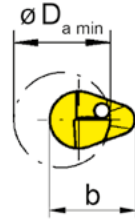
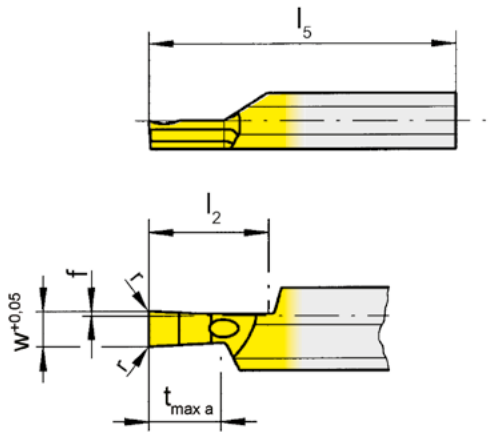
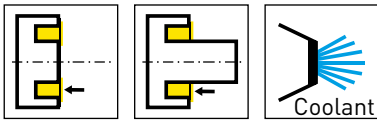

Coating grades

R = right hand version shown

L = left hand version

▲ In stock

Δ 2 weeks

Part number	w	r	f	b	l ₂	l ₅	t _{max a}	D _{a min}	HIS	EG35	IG35	TI25
R105.0810.1.9	1	0.15	0.4	7	10	25	2	8	105125	▲	▲	▲
R105.0815.1.9	1.5	0.15	0.4	7	10	25	3	8	105125	▲		▲
R105.0820.1.9	2	0.15	0.4	7	10	25	4	8	105125	▲		▲
R105.0825.1.9	2.5	0.15	0.4	7	10	25	5	8	105125	▲		▲
R105.0830.1.9	3	0.15	0.4	7	10	25	6	8	105125	▲	▲	▲
L105.0810.1.9	1	0.15	0.4	7	10	25	2	8	105125	▲		▲
L105.0815.1.9	1.5	0.15	0.4	7	10	25	3	8	105125	▲	▲	▲
L105.0820.1.9	2	0.15	0.4	7	10	25	4	8	105125	▲		▲
L105.0825.1.9	2.5	0.15	0.4	7	10	25	5	8	105125	▲		▲
L105.0830.1.9	3	0.15	0.4	7	10	25	6	8	105125	▲		▲

Dimensions in mm

P	●	●	●
M	●	●	●
K	●	●	-
N	○	○	●
S	-	○	-
H	-	-	-

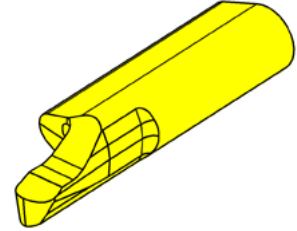
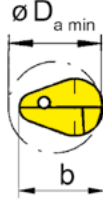
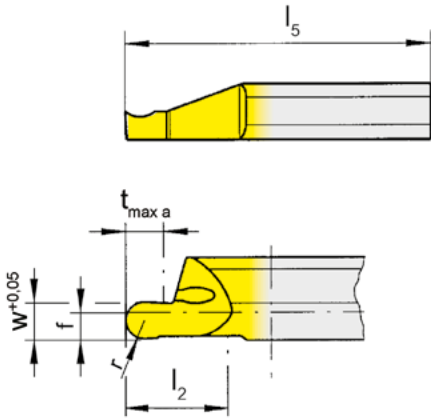
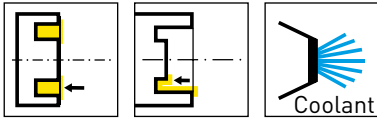

Coating grades

R = right hand version shown

L = left hand version

▲ In stock

△ 2 weeks

Part number	w	r	f	b	l_2	l_5	$t_{max a}$	$D_{a min}$	HIS	IG35	TH35	TI25
RU105.FF12.1.8	.125	.063	.079	.276	.394	.984	.236	.315	105125	▲	▲	▲
RU105.FF12.2.8	.125	.063	.079	.276	.591	1.378	.236	.315	105125	▲	▲	▲
RU105.FF46.1.8	.046	.023	.079	.276	.394	.984	.098	.315	105125	▲	▲	▲
RU105.FF46.2.8	.046	.023	.079	.276	.591	1.378	.098	.315	105125	▲	▲	▲
RU105.FF62.1.8	.062	.031	.079	.276	.394	.984	.118	.315	105125	▲	▲	▲
RU105.FF62.2.8	.062	.031	.079	.276	.591	1.378	.118	.315	105125	▲	▲	▲
RU105.FF78.1.8	.078	.039	.079	.276	.394	.984	.157	.315	105125	▲	▲	▲
RU105.FF78.2.8	.078	.039	.079	.276	.591	1.378	.157	.315	105125	▲	▲	▲
RU105.FF94.1.8	.094	.047	.079	.276	.394	.984	.197	.315	105125	▲	▲	▲
RU105.FF94.2.8	.094	.047	.079	.276	.591	1.378	.197	.315	105125	▲	▲	▲
LU105.FF12.1.8	.125	.063	.079	.276	.394	.984	.236	.315	105125	▲		▲
LU105.FF46.1.8	.046	.023	.079	.276	.394	.984	.098	.315	105125	▲		▲
LU105.FF62.1.8	.062	.031	.079	.276	.394	.984	.118	.315	105125	▲		▲
LU105.FF78.1.8	.078	.039	.079	.276	.394	.984	.157	.315	105125	▲		▲

Dimensions in inch



P	●	●	●
M	●	●	●
K	●	●	-
N	o	-	●
S	o	-	-
H	-	-	-

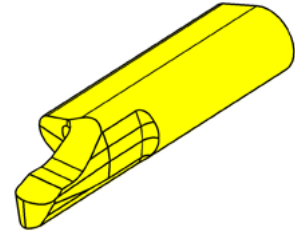
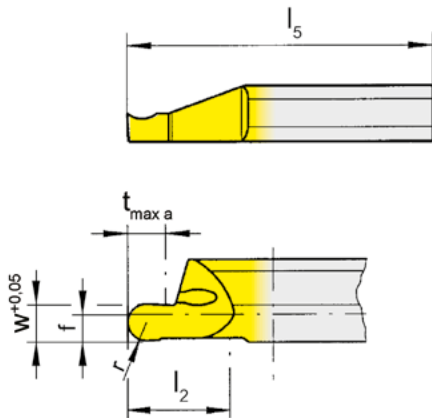
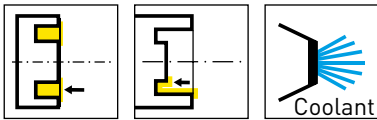

Coating grades

R = right hand version shown

L = left hand version

▲ In stock

△ 2 weeks

Part number	w	r	f	b	l ₂	l ₅	t _{max a}	D _{a min}	HIS	EG35	IG35	TI25
R105.8V10.1.8	1	0.5	2	7	10	25	2	8	105125	▲	▲	▲
R105.8V16.1.8	1.6	0.8	2	7	10	25	3	8	105125	▲		▲
R105.8V20.1.8	2	1	2	7	10	25	4	8	105125	▲		▲
R105.8V25.1.8	2.5	1.25	2	7	10	25	5	8	105125	▲		▲
R105.8V30.1.8	3	1.5	2	7	10	25	6	8	105125	▲		▲
R105.8V10.2.8	1	0.5	2	7	15	35	2	8	105125	▲		▲
R105.8V16.2.8	1.6	0.8	2	7	15	35	3	8	105125	▲		▲
R105.8V20.2.8	2	1	2	7	15	35	4	8	105125	▲		▲
R105.8V25.2.8	2.5	1.25	2	7	15	35	5	8	105125	▲		▲
R105.8V30.2.8	3	1.5	2	7	15	35	6	8	105125	▲		▲
L105.8V10.1.8	1	0.5	2	7	10	25	2	8	105125	▲		▲
L105.8V16.1.8	1.6	0.8	2	7	10	25	3	8	105125	▲		▲
L105.8V20.1.8	2	1	2	7	10	25	4	8	105125	▲		▲
L105.8V25.1.8	2.5	1.25	2	7	10	25	5	8	105125	△		▲
L105.8V30.1.8	3	1.5	2	7	10	25	6	8	105125	▲		▲
L105.8V10.2.8	1	0.5	2	7	15	35	2	8	105125	▲		▲
L105.8V16.2.8	1.6	0.8	2	7	15	35	3	8	105125	△		▲
L105.8V20.2.8	2	1	2	7	15	35	4	8	105125	▲		▲
L105.8V25.2.8	2.5	1.25	2	7	15	35	5	8	105125	△		△
L105.8V30.2.8	3	1.5	2	7	15	35	6	8	105125	△		▲

Dimensions in mm

P	●	●	●
M	●	●	●
K	●	●	-
N	○	○	●
S	-	○	-
H	-	-	-

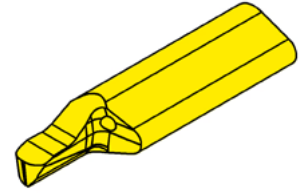
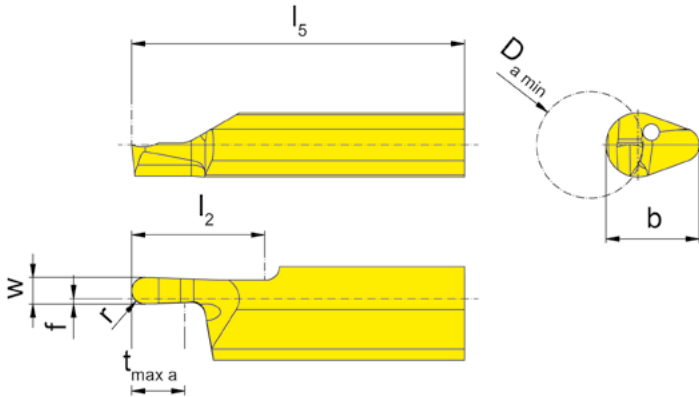
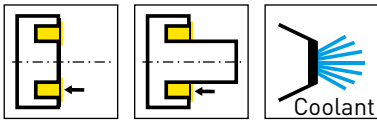

Coating grades

R = right hand version shown

L = left hand version

▲ In stock

Δ 2 weeks

Part number	w	r	f	b	l_2	l_5	$t_{\max a}$	$D_{a \min}$	HIS	EG35
R105.8V10.1.9	1	0.5	0.4	7	10	25	2	8	105125	▲
R105.8V16.1.9	1.6	0.8	0.4	7	10	25	3	8	105125	▲
R105.8V20.1.9	2	1	0.4	7	10	25	4	8	105125	▲
R105.8V25.1.9	2.5	1.25	0.4	7	10	25	5	8	105125	▲
R105.8V30.1.9	3	1.5	1	7	10	25	6	8	105125	▲
L105.8V10.1.9	1	0.5	0.4	7	10	25	2	8	105125	▲
L105.8V16.1.9	1.6	0.8	0.4	7	10	25	3	8	105125	▲
L105.8V20.1.9	2	1	0.4	7	10	25	4	8	105125	▲
L105.8V25.1.9	2.5	1.25	0.4	7	10	25	5	8	105125	▲
L105.8V30.1.9	3	1.5	1	7	10	25	6	8	105125	▲

Dimensions in mm

P	●
M	●
K	●
N	o
S	-
H	-

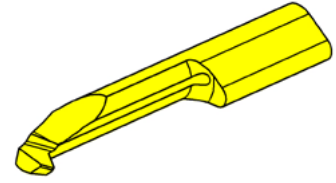
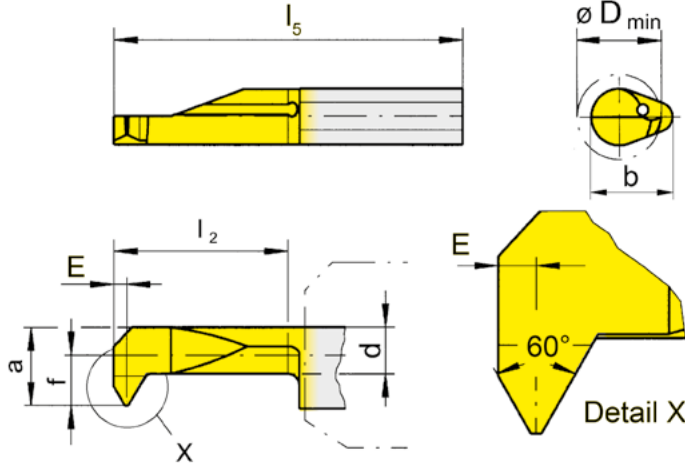
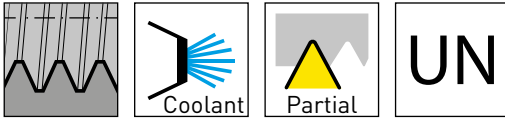

Coating grades

R = right hand version shown

L = left hand version

▲ In stock

Δ 2 weeks

Part number	TPI _{min}	TPI _{max}	E	w	t _{max}	f	a	d	b	l ₂	l ₅	D _{min}	HIS	EG35	IG35	TF45	TH35	TN35
R105.3240.2.4	32	40	0.45	0.07	0.4	1.9	3.7	2.7	6.4	15	30	4	105124	▲	▲			▲
R105.1620.2.5	16	20	0.7	0.15	0.9	2.3	4.7	3.3	7	15	30	5	105125	▲	▲		▲	
R105.1620.3.5	16	20	0.7	0.15	0.9	2.3	4.7	3.3	7	20	35	5	105125	Δ	▲		▲	
R105.2428.2.5	24	28	0.55	0.10	0.6	2.3	4.7	3.5	7	15	30	5	105125	▲			▲	▲
R105.3240.2.5	32	40	0.45	0.07	0.4	2.3	4.7	3.5	7	15	30	5	105125	▲	▲			▲
R105.1620.2.6	16	20	0.7	0.15	0.9	3.3	5.7	3.7	7	15	30	6	105125	▲	▲		▲	▲
R105.1620.3.6	16	20	0.7	0.15	0.9	3.3	5.7	3.7	7	20	35	6	105125	▲	▲			▲
R105.1620.4.6	16	20	0.7	0.15	0.9	3.3	5.7	3.7	7	25	40	6	105125	▲	▲			▲
R105.2428.2.6	24	28	0.55	0.10	0.6	3.3	5.7	3.7	7	15	30	6	105125	▲	▲			▲
R105.2428.3.6	24	28	0.55	0.10	0.6	3.3	5.7	3.7	7	20	35	6	105125	▲				▲
R105.2428.4.6	24	28	0.55	0.10	0.6	3.3	5.7	3.7	7	25	40	6	105125	▲				▲
L105.3240.2.4	32	40	0.45	0.07	0.4	1.9	3.7	2.7	6.4	15	30	4	105124	Δ		Δ		▲
L105.1620.2.5	16	20	0.7	0.15	0.9	2.3	4.7	3.3	7	15	30	5	105125	Δ			▲	
L105.1620.3.5	16	20	0.7	0.15	0.9	2.3	4.7	3.3	7	20	35	5	105125	Δ			▲	
L105.2428.2.5	24	28	0.55	0.10	0.6	2.3	4.7	3.5	7	15	30	5	105125	▲				▲
L105.3240.2.5	32	40	0.45	0.07	0.4	2.3	4.7	3.5	7	15	30	5	105125	Δ		Δ		▲
L105.1620.2.6	16	20	0.7	0.07	0.9	3.3	5.7	3.7	7	15	30	6	105125	▲	▲			▲
L105.1620.3.6	16	20	0.7	0.15	0.9	3.3	5.7	3.7	7	20	35	6	105125	Δ				Δ
L105.1620.4.6	16	20	0.7	0.15	0.9	3.3	5.7	3.7	7	25	40	6	105125	▲				Δ
L105.2428.2.6	24	28	0.55	0.10	0.6	3.3	5.7	3.7	7	15	30	6	105125	▲	▲			▲
L105.2428.3.6	24	28	0.55	0.10	0.6	3.3	5.7	3.7	7	20	35	6	105125	Δ				▲
L105.2428.4.6	24	28	0.55	0.10	0.6	3.3	5.7	3.7	7	25	40	6	105125	Δ				▲

Dimensions in mm



	P	M	K	N	S	H
EG35	●	●	●	○	-	-
IG35	●	●	●	○	-	-
TF45	-	-	-	-	-	-
TH35	●	●	●	○	-	-
TN35	●	-	●	○	-	-

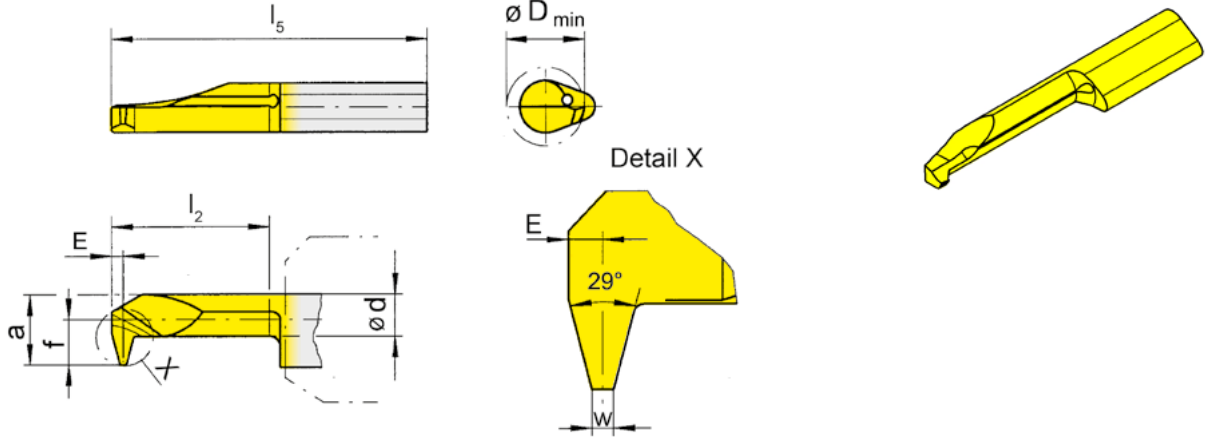
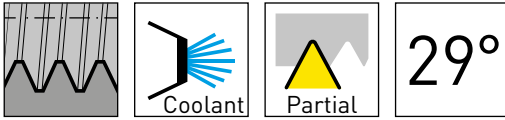

Coating grades

R = right hand version shown

▲ In stock

Δ 2 weeks

Part number	TPI	E	w	t _{max}	f	a	d	l ₂	l ₅	D _{min}	HIS	IG35	TH35	TI25	TN35
RU105.AC10.3.7	10	.039	.031	.067	.157	.252	.173	.787	1.378	.394	105125	▲	▲		▲
RU105.AC12.3.7	12	.039	.027	.051	.157	.252	.189	.787	1.378	.276	105125	▲	▲		▲
RU105.AC12.5.7	12	.039	.027	.051	.157	.252	.189	1.181	1.772	.276	105125	▲	▲		▲
RU105.AC14.2.6	14	.035	.023	.043	.130	.224	.169	.591	1.181	.236	105125	▲	▲		▲
RU105.AC14.4.6	14	.035	.023	.043	.130	.224	.169	.984	1.575	.236	105125	▲	▲		▲
RU105.AC16.2.5	16	.028	.019	.039	.079	.173	.122	.591	1.181	.189	105125	▲		▲	▲
RU105.AC16.4.5	16	.028	.019	.039	.079	.173	.122	.984	1.575	.189	105125	▲	▲		▲

Inserts with ".AC" are designed for standard ACME threads. Inserts with ".SA" are designed for stub ACME threads.

Dimensions in inch



P	●	●	●	●
M	●	●	●	-
K	●	●	-	●
N	○	-	●	○
S	○	-	-	-
H	-	-	-	-

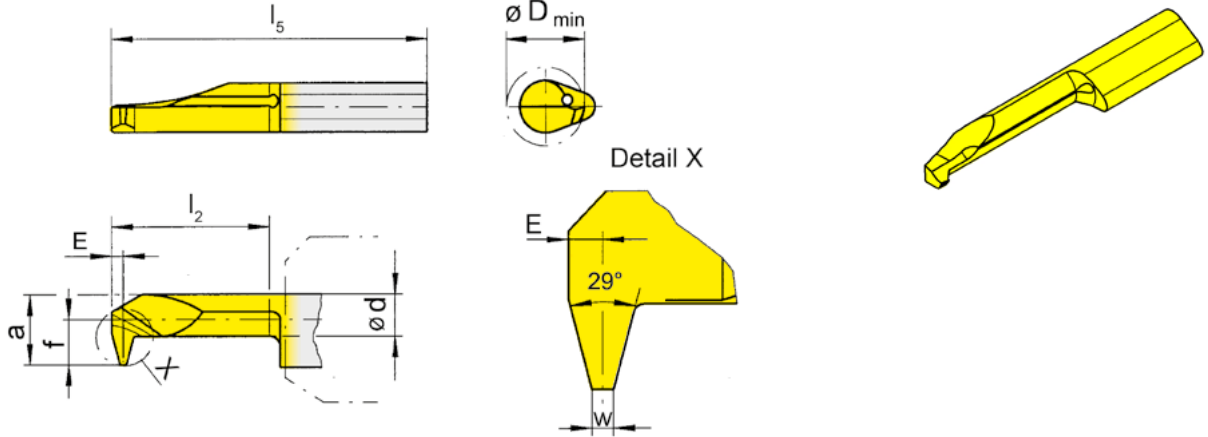
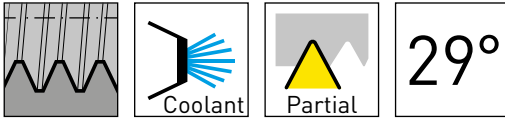

Coating grades

R = right hand version shown

▲ In stock

Δ 2 weeks

Part number	TPI	w	t _{max}	E	f	a	d	l ₂	l ₅	D _{min}	HIS	IG35	TH35	TI25	TN35
RU105.SA10.3.7	10	.037	.047	.039	.157	.252	.193	.787	1.378	.433	105125	▲	▲		Δ
RU105.SA12.3.7	12	.032	.039	.039	.157	.252	.201	.787	1.378	.323	105125	▲	▲		▲
RU105.SA12.5.7	12	.032	.039	.039	.157	.252	.201	1.181	1.772	.323	105125	▲	▲	Δ	▲
RU105.SA14.2.6	14	.027	.035	.035	.130	.224	.177	.591	1.181	.268	105125	▲	▲		▲
RU105.SA14.4.6	14	.027	.035	.035	.130	.224	.177	.984	1.575	.268	105125	▲	▲		▲
RU105.SA16.2.5	16	.023	.031	.028	.091	.185	.142	.591	1.181	.201	105125	▲	▲		▲
RU105.SA16.4.5	16	.023	.031	.028	.091	.185	.142	.984	1.575	.201	105125	▲	▲		▲

Inserts with ".AC" are designed for standard ACME threads. Inserts with ".SA" are designed for stub ACME threads.

Dimensions in inch



P	●	●	●	●
M	●	●	●	-
K	●	●	-	●
N	○	-	●	○
S	○	-	-	-
H	-	-	-	-

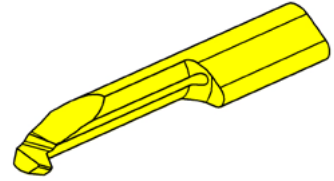
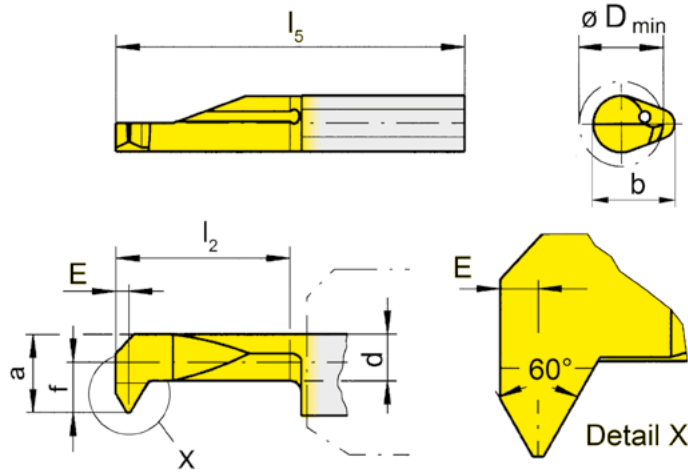
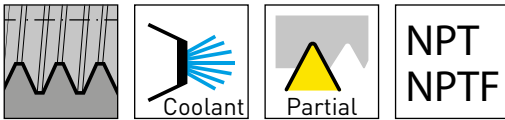

Coating grades

R = right hand version shown

L = left hand version

▲ In stock

Δ 2 weeks

Part number	TPI	E	f	a	d	b	l ₂	l ₅	D _{min}	HIS	Coating grades			
											EG35	IG35	TH35	TN35
R105.NP18.2.6	18	1	3.3	5.7	3.7	7	15	30	6	105125	▲	▲		▲
R105.NP18.3.6	18	1	3.3	5.7	3.7	7	20	35	6	105125	Δ		Δ	▲
R105.NP18.4.6	18	1	3.3	5.7	3.7	7	25	40	6	105125	Δ		Δ	▲
R105.NP27.2.6	27	0.8	3.3	5.7	3.7	7	15	30	6	105125	▲	▲		▲
R105.NP27.3.6	27	0.8	3.3	5.7	3.7	7	20	35	6	105125	Δ		Δ	Δ
R105.NP27.4.6	27	0.8	3.3	5.7	3.7	7	25	40	6	105125	Δ		Δ	Δ
L105.NP18.2.6	18	1	3.3	5.7	3.7	7	15	30	6	105125	Δ			▲
L105.NP18.3.6	18	1	3.3	5.7	3.7	7	20	35	6	105125	Δ		Δ	Δ
L105.NP18.4.6	18	1	3.3	5.7	3.7	7	25	40	6	105125	Δ		Δ	Δ
L105.NP27.2.6	27	0.8	3.3	5.7	3.7	7	15	30	6	105125	Δ			▲
L105.NP27.3.6	27	0.8	3.3	5.7	3.7	7	20	35	6	105125	Δ		Δ	
L105.NP27.4.6	27	0.8	3.3	5.7	3.7	7	25	40	6	105125	Δ		Δ	Δ

Dimensions in mm

	P	M	K	N	S	H
EG35	●	●	●	○	-	-
IG35	●	●	●	○	○	-
TH35	●	●	●	-	-	-
TN35	●	-	●	○	-	-

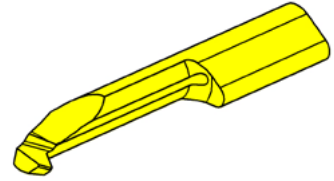
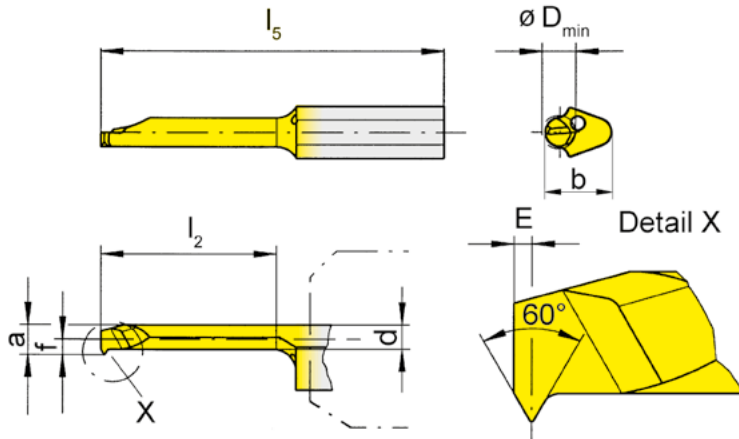
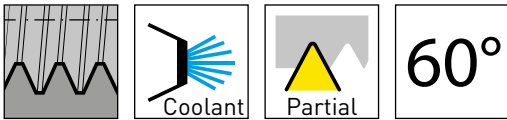

Coating grades

R = right hand version shown

L = left hand version

▲ In stock

Δ 2 weeks

Part number	P	E	f	a	d	b	l_2	l_5	D_{min}	HIS	EG35	TN35
R105.0102.2.3	0.25	0.3	1.4	2.7	2.2	5.9	15	30	3	105123	Δ	▲
L105.0102.2.3	0.25	0.3	1.4	2.7	2.2	5.9	15	30	3	105123	Δ	▲

Dimensions in mm

P	●	●
M	●	-
K	●	●
N	○	○
S	-	-
H	-	-

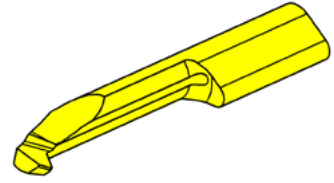
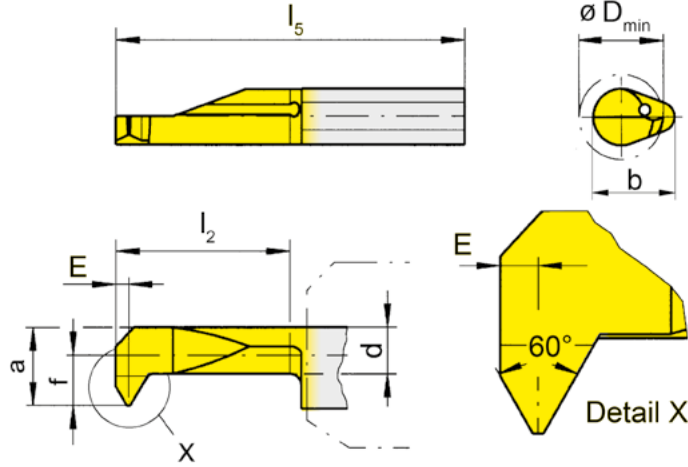
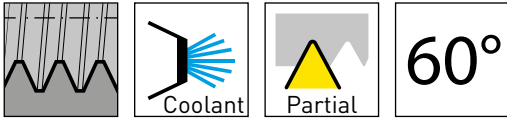

Coating grades

R = right hand version shown

L = left hand version

▲ In stock

Δ 2 weeks

Part number	P	E	f	a	d	b	l ₂	l ₅	D _{min}	HIS	Coating grades				
											EG35	IG35	TN35		
R105.0203.1.3	0.35	0.3	1.4	2.7	2.1	5.9	10	25	3	105123	▲	▲	▲		
R105.0203.2.5	0.35	0.3	2.3	4.7	3.5	7	15	30	5	105125	▲	▲	▲		
L105.0203.1.3	0.35	0.3	1.4	2.7	2.1	5.9	10	25	3	105123	Δ		▲		
L105.0203.2.5	0.35	0.3	2.3	4.7	3.5	7	15	30	5	105125			▲		
Dimensions in mm												P	●	●	●
												M	●	●	-
												K	●	●	●
												N	○	○	○
												S	-	○	-
												H	-	-	-

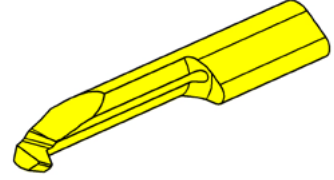
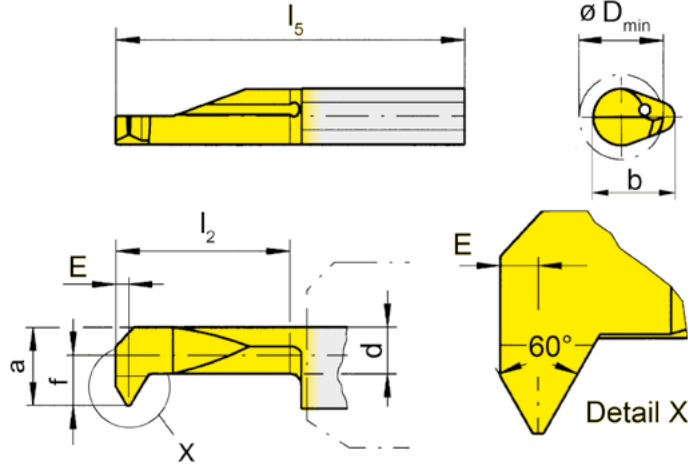
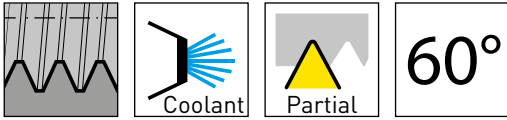

Coating grades

R = right hand version shown

L = left hand version

▲ In stock

△ 2 weeks

Part number	P	TPI	TPI _{max}	E	f	a	d	b	l ₂	l ₅	D _{min}	HIS	EG35	IG35	TH35	TN35
R105.0205.2.3	0.5	-	-	0.35	1.4	2.7	2.1	5.9	15	30	3	105123	▲	▲		▲
R105.0205.2.4	0.5	32	64	0.35	1.9	3.7	2.7	6.4	15	30	4	105124	▲	▲	▲	▲
R105.0205.3.4	0.5	32	64	0.35	1.9	3.7	2.7	6.4	20	35	4	105124	▲			△
R105.0205.2.5	0.5	32	64	0.35	2.3	4.7	3.5	7	15	30	5	105125	▲	▲	▲	▲
R105.0205.3.5	0.5	32	64	0.35	2.3	4.7	3.5	7	20	35	5	105125	△			▲
R105.0205.4.5	0.5	32	64	0.35	2.3	4.7	3.5	7	25	40	5	105125				▲
R105.0205.3.6	0.5	-	-	0.35	3.3	5.7	4.8	7	20	35	6	105125	▲			▲
L105.0205.2.3	0.5	-	-	0.35	1.4	2.7	2.1	5.9	15	30	3	105123	△			▲
L105.0205.2.4	0.5	32	64	0.35	1.9	3.7	2.7	6.4	15	30	4	105124	△			▲
L105.0205.3.4	0.5	32	64	0.35	1.9	3.7	2.7	6.4	20	35	4	105124	△			▲
L105.0205.2.5	0.5	32	64	0.35	2.3	4.7	3.5	7	15	30	5	105125	△		▲	▲
L105.0205.3.5	0.5	32	64	0.35	2.3	4.7	3.5	7	20	35	5	105125	△			△
L105.0205.4.5	0.5	32	64	0.35	2.3	4.7	3.5	7	25	40	5	105125	△			△
L105.0205.3.6	0.5	-	-	0.35	3.3	5.7	4.8	7	20	35	6	105125	△			

Dimensions in mm

	P	M	K	N	S	H
EG35	●	●	●	○	-	-
IG35	●	●	●	○	-	-
TH35	●	●	●	-	-	-
TN35	●	-	●	○	-	-

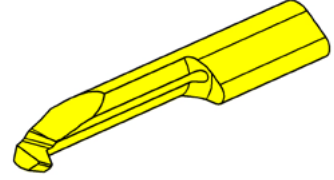
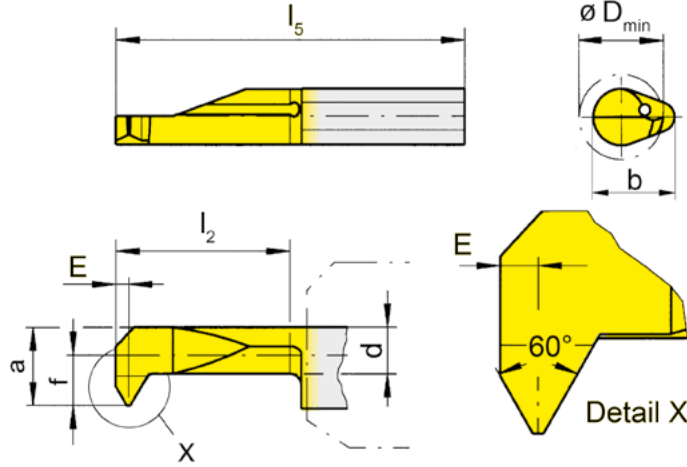
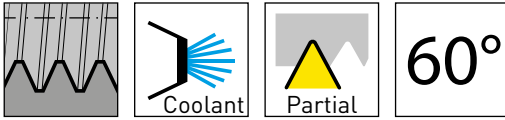

Coating grades

R = right hand version shown

L = left hand version

▲ In stock

△ 2 weeks

Part number	P	TPI	TPI _{max}	E	f	a	d	b	l ₂	l ₅	D _{min}	HIS	Coating grades			
													EG35	IG35	TH35	TN35
R105.0407.2.3	0.75	-	-	0.45	1.4	2.7	2	5.9	15	30	3	105123	▲	▲		▲
R105.0407.1.4	0.75	-	-	0.45	1.9	3.7	2.7	6.4	10	25	4	105124	▲			▲
R105.0407.2.4	0.75	-	-	0.45	1.9	3.7	2.7	6.4	15	30	4	105124	▲			▲
R105.0407.3.4	0.75	-	-	0.45	1.9	3.7	2.7	6.4	20	35	4	105124	▲			▲
R105.0407.2.5	0.75	28	64	0.45	2.3	4.7	3.5	7	15	30	5	105125	▲	▲	▲	▲
R105.0407.3.5	0.75	28	64	0.45	2.3	4.7	3.5	7	20	35	5	105125	△			▲
R105.0407.4.5	0.75	28	64	0.45	2.3	4.7	3.5	7	25	40	5	105125	▲			▲
R105.0407.3.6	0.75	-	-	0.45	3.3	5.7	4.7	7	20	35	6	105125	▲			▲
L105.0407.2.3	0.75	-	-	0.45	1.4	2.7	2	5.9	15	30	3	105123	△			
L105.0407.1.4	0.75	-	-	0.45	1.9	3.7	2.7	6.4	10	25	4	105124	△			▲
L105.0407.2.4	0.75	-	-	0.45	1.9	3.7	2.7	6.4	15	30	4	105124	△			▲
L105.0407.3.4	0.75	-	-	0.45	1.9	3.7	2.7	6.4	20	35	4	105124	△			△
L105.0407.2.5	0.75	28	64	0.45	2.3	4.7	3.5	7	15	30	5	105125	▲		▲	▲
L105.0407.3.5	0.75	28	64	0.45	2.3	4.7	3.5	7	20	35	5	105125	△			△
L105.0407.4.5	0.75	28	64	0.45	2.3	4.7	3.5	7	25	40	5	105125	△			△
L105.0407.3.6	0.75	-	-	0.45	3.3	5.7	4.7	7	20	35	6	105125	△			
P	●	●	●	●									●	●	●	●
M	●	●	●	●									●	●	●	-
K	●	●	●	●									●	●	●	●
N	○	○	○	○									○	○	-	○
S	-	-	-	-									-	-	-	-
H	-	-	-	-									-	-	-	-

Dimensions in mm

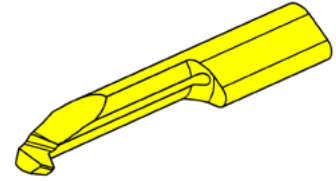
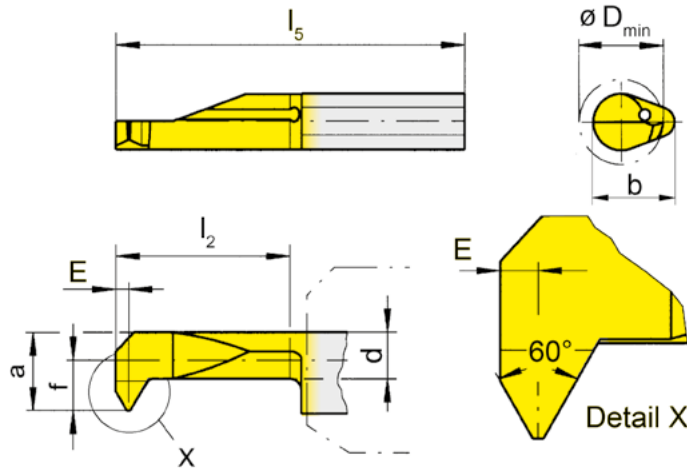
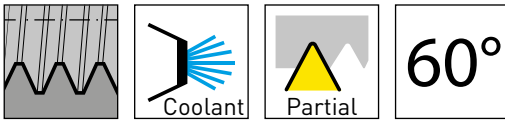

Coating grades

R = right hand version shown

L = left hand version

▲ In stock

△ 2 weeks

Part number	P	TPI	TPI _{max}	E	f	a	d	b	l ₂	l ₅	D _{min}	HIS	Coating grades			
													EG35	IG35	TH35	TN35
R105.0510.2.5	1	-	-	0.55	2.1	4.5	3.5	7	15	30	4.8	105125	▲	▲	▲	▲
R105.0510.3.5	1	-	-	0.55	2.1	4.5	3.5	7	20	35	4.8	105125	▲	▲		▲
R105.0510.4.5	1	-	-	0.55	2.1	4.5	3.5	7	25	40	4.8	105125	▲			▲
R105.0510.2.6	1	24	32	0.55	3.3	5.7	3.7	7	15	30	6	105125	▲		▲	▲
R105.0612.2.6	1.25	18	24	0.65	3.3	5.7	3.7	7	15	30	6	105125	▲		▲	▲
R105.0612.3.6	1.25	18	24	0.65	3.3	5.7	3.7	7	20	35	6	105125	▲			▲
R105.0612.4.6	1.25	18	24	0.65	3.3	5.7	3.7	7	25	40	6	105125	▲	▲		▲
R105.0815.2.7	1.5	16	24	0.75	4	6.4	3.7	7	15	30	7	105125	▲		▲	▲
R105.0815.3.7	1.5	16	24	0.75	4	6.4	3.7	7	20	35	7	105125	▲			▲
R105.0815.4.7	1.5	16	24	0.75	4	6.4	3.7	7	25	40	7	105125	▲			▲
L105.0510.2.5	1	-	-	0.55	2.1	4.5	3.5	7	15	30	4.8	105125	▲	▲	▲	▲
L105.0510.3.5	1	-	-	0.55	2.1	4.5	3.5	7	20	35	4.8	105125	△			▲
L105.0510.4.5	1	-	-	0.55	2.1	4.5	3.5	7	25	40	4.8	105125	△			▲
L105.0510.2.6	1	24	32	0.55	3.3	5.7	3.7	7	15	30	6	105125	▲		▲	▲
L105.0612.2.6	1.25	18	24	0.65	3.3	5.7	3.7	7	15	30	6	105125	▲		▲	▲
L105.0612.3.6	1.25	18	24	0.65	3.3	5.7	3.7	7	20	35	6	105125	△			▲
L105.0612.4.6	1.25	18	24	0.65	3.3	5.7	3.7	7	25	40	6	105125	△			▲
L105.0815.2.7	1.5	16	24	0.75	4	6.4	3.7	7	15	30	7	105125			▲	▲
L105.0815.3.7	1.5	16	24	0.75	4	6.4	3.7	7	20	35	7	105125	△			▲
L105.0815.4.7	1.5	16	24	0.75	4	6.4	3.7	7	25	40	7	105125	△			▲

Dimensions in mm

P	●	●	●	●
M	●	●	●	-
K	●	●	●	●
N	○	○	-	○
S	-	○	-	-
H	-	-	-	-

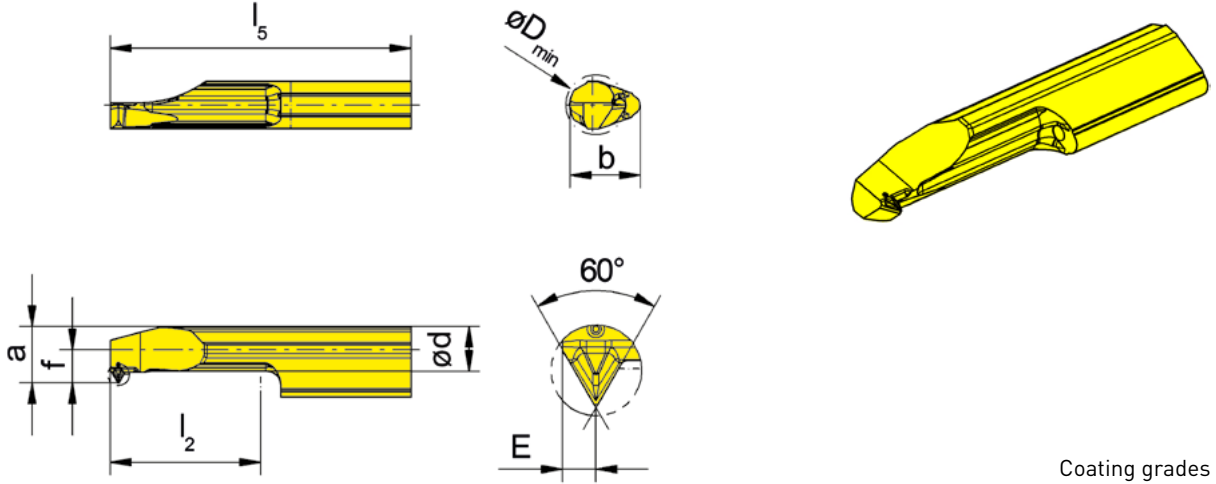
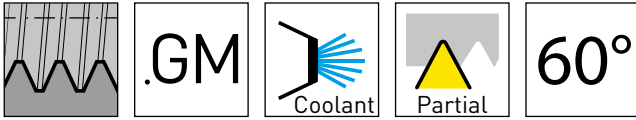

Coating grades

R = right hand version

▲ In stock

Δ 2 weeks

Part number	P	P _{max}	TPI	TPI _{max}	E	f	d	b	l ₂	l ₅	D _{min}	HIS	TH35
RS105.1010.2.5.GM1	1	1	24	32	0.8	3.3	3.5	7	15	30	4.8	105125	▲
RS105.1010.3.5.GM1	1	1	24	32	0.8	3.3	3.5	7	20	35	4.8	105125	▲
RS105.0507.2.5.GM1	0.5	0.75	28	64	0.8	3.3	3.7	7	15	30	5	105125	▲
RS105.0507.3.5.GM1	0.5	0.75	28	64	0.8	3.3	3.7	7	20	35	5	105125	▲
RS105.1012.2.6.GM1	1	1.25	18	32	0.8	3.3	4.43	7	15	30	6	105125	▲
RS105.1012.3.6.GM1	1	1.25	18	32	0.8	3.3	4.43	7	20	35	6	105125	▲
RS105.1012.4.6.GM1	1	1.25	18	32	0.8	3.3	4.43	7	25	40	6	105125	▲
RS105.1515.2.6.GM1	1.5	1.5	16	24	0.8	3.3	4.43	7	15	30	6.8	105125	▲
RS105.1515.3.6.GM1	1.5	1.5	16	24	0.8	3.3	4.43	7	20	35	6.8	105125	▲
RS105.1515.4.6.GM1	1.5	1.5	16	24	0.8	3.3	4.43	7	25	40	6.8	105125	▲

Dimensions in mm

P	●
M	●
K	●
N	-
S	-
H	-

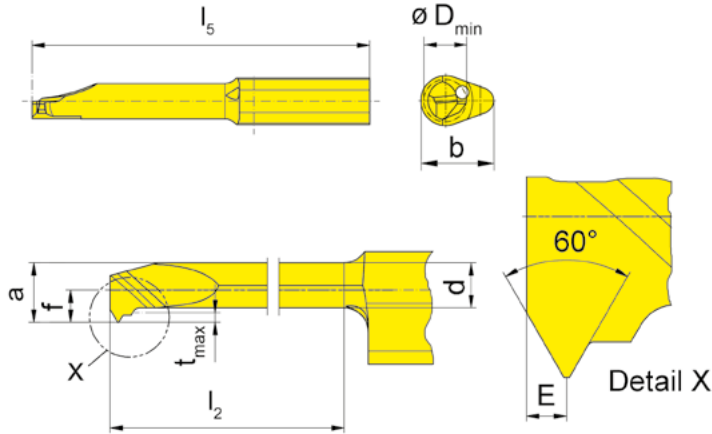
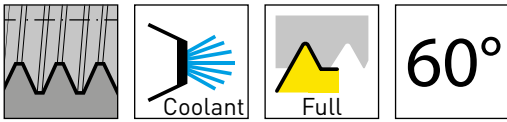

Coating grades

R = right hand version shown

L = left hand version

▲ In stock

△ 2 weeks

Part number	P	E	f	a	d	b	l ₂	l ₅	D _{min}	HIS	EG35	TH35
R105.VPM3.2.3	0.5	0.3	1.4	2.2	1.65	5.9	9	25	2.4	105123	▲	▲
R105.VPM3.4.3	0.5	0.3	1.4	2.2	1.65	5.9	16	35	2.4	105123	▲	▲
R105.VPM4.2.4	0.7	0.4	1.5	2.9	2.1	6.4	15	30	3.2	105124	▲	▲
R105.VPM4.3.4	0.7	0.4	1.5	2.9	2.1	6.4	20	35	3.2	105124	▲	▲
R105.VPM5.2.5	0.8	0.5	2	3.7	2.8	7	15	30	4.1	105125	▲	▲
R105.VPM5.4.5	0.8	0.5	2	3.7	2.8	7	25	40	4.1	105125	▲	▲
R105.VPM6.3.6	1	0.5	2.4	4.5	3.4	7	20	35	4.9	105125	▲	▲
R105.VPM6.4.6	1	0.5	2.4	4.5	3.4	7	25	40	4.9	105125	▲	△
R105.VPM6.5.6	1	0.5	2.4	4.5	3.4	7	30	45	4.9	105125	▲	▲
R105.VPM8.3.8	1.25	0.7	3.8	6.2	4.7	7	20	35	6.6	105125	▲	▲
R105.VPM8.5.8	1.25	0.7	3.8	6.2	4.7	7	30	45	6.6	105125	▲	▲
L105.VPM3.2.3	0.5	0.3	1.4	2.2	1.65	5.9	9	25	2.4	105123	△	▲
L105.VPM3.4.3	0.5	0.3	1.4	2.2	1.65	5.9	16	35	2.4	105123	△	▲
L105.VPM4.2.4	0.7	0.4	1.5	2.9	2.1	6.4	15	30	3.2	105124	△	▲
L105.VPM4.3.4	0.7	0.4	1.5	2.9	2.1	6.4	20	35	3.2	105124	△	▲
L105.VPM5.2.5	0.8	0.5	2	3.7	2.8	7	15	30	4.1	105125	△	▲
L105.VPM5.4.5	0.8	0.5	2	3.7	2.8	7	25	40	4.1	105125	△	▲
L105.VPM6.3.6	1	0.5	2.4	4.5	3.4	7	20	35	4.9	105125	▲	▲
L105.VPM6.4.6	1	0.5	2.4	4.5	3.4	7	25	40	4.9	105125	△	△
L105.VPM6.5.6	1	0.5	2.4	4.5	3.4	7	30	45	4.9	105125	△	▲
L105.VPM8.3.8	1.25	0.7	3.8	6.2	4.7	7	20	35	6.6	105125	△	▲
L105.VPM8.5.8	1.25	0.7	3.8	6.2	4.7	7	30	45	6.6	105125	△	▲

Dimensions in mm

P	●	●
M	●	●
K	●	●
N	○	-
S	-	-
H	-	-

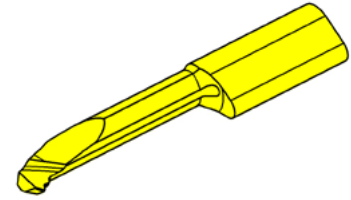
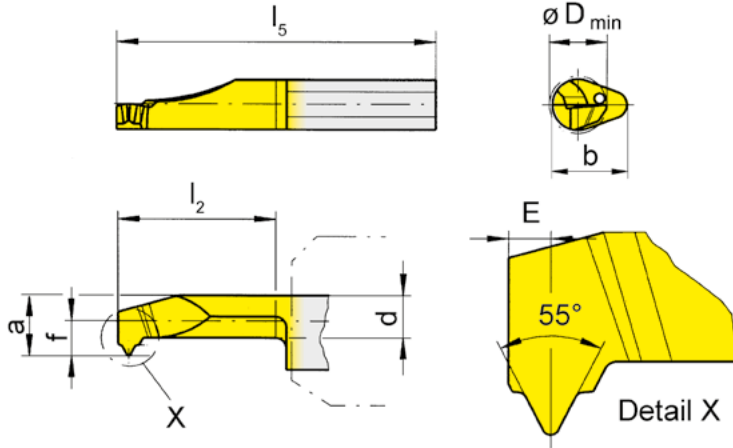
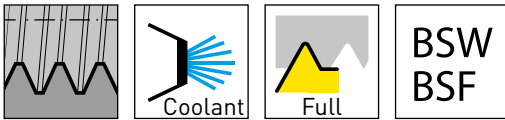

Coating grades

R = right hand version shown

L = left hand version

▲ In stock

△ 2 weeks

Part number	TPI	E	f	a	d	b	l_2	l_5	D_{min}	HIS	EG35	TN35
R105.5520.2.4	20	1	1.9	3.7	2.5	6.4	15	30	4	105124	▲	▲
R105.5524.2.5	24	0.8	2.3	4.7	3.5	7	15	30	5	105125	△	△
R105.5526.2.5	26	0.8	2.3	4.7	3.5	7	15	30	5	105125		▲
R105.5528.2.5	28	0.8	2.3	4.7	3.5	7	15	30	5	105125	▲	▲
L105.5524.2.5	24	0.8	2.3	4.7	3.5	7	15	30	5	105125	△	△
L105.5526.2.5	26	0.8	2.3	4.7	3.5	7	15	30	5	105125	△	△
L105.5528.2.5	28	0.8	2.3	4.7	3.5	7	15	30	5	105125	△	△

Dimensions in mm

P	●	●
M	●	-
K	●	●
N	○	○
S	-	-
H	-	-

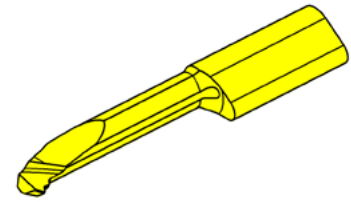
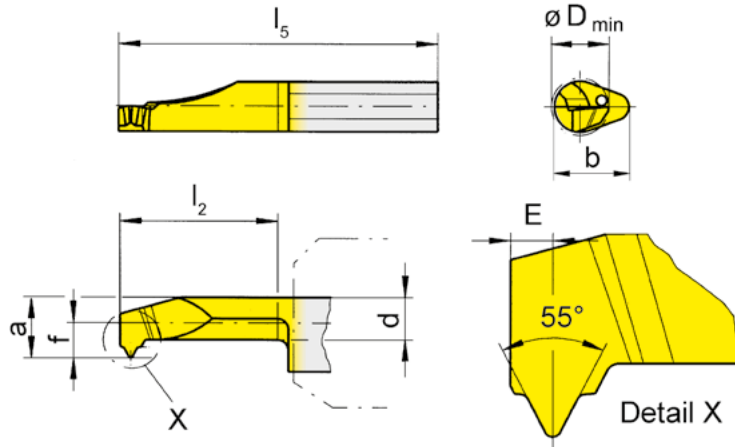
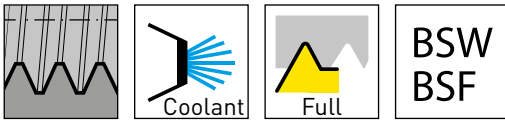

Coating grades

R = right hand version shown

L = left hand version

▲ In stock

△ 2 weeks

Part number	TPI	E	f	a	d	b	l_2	l_5	D_{min}	HIS	EG35	TN35
R105.5524.2.6	24	0.8	3.3	5.7	3.7	7	15	30	6	105125	△	▲
R105.5526.2.6	26	0.8	3.3	5.7	3.7	7	15	30	6	105125	△	▲
R105.5528.2.6	28	0.8	3.3	5.7	3.7	7	15	30	6	105125	▲	▲
R105.5519.2.6	19	1	3.3	5.7	3.7	7	15	30	6	105125	▲	▲
R105.5520.2.6	20	1	3.3	5.7	3.7	7	15	30	6	105125	△	▲
R105.5522.2.6	22	1	3.3	5.7	3.7	7	15	30	6	105125	△	△
R105.5524.3.6	24	0.8	3.3	5.7	3.7	7	20	35	6	105125	△	△
R105.5526.3.6	26	0.8	3.3	5.7	3.7	7	20	35	6	105125	△	△
R105.5528.3.6	28	0.8	3.3	5.7	3.7	7	20	35	6	105125	▲	▲
R105.5519.3.6	19	1	3.3	5.7	3.7	7	20	35	6	105125	▲	▲
R105.5522.3.6	22	1	3.3	5.7	3.7	7	20	35	6	105125	△	△
L105.5524.2.6	24	0.8	3.3	5.7	3.7	7	15	30	6	105125	△	△
L105.5526.2.6	26	0.8	3.3	5.7	3.7	7	15	30	6	105125	△	△
L105.5528.2.6	28	0.8	3.3	5.7	3.7	7	15	30	6	105125	△	△
L105.5519.2.6	19	1	3.3	5.7	3.7	7	15	30	6	105125	△	▲
L105.5520.2.6	20	1	3.3	5.7	3.7	7	15	30	6	105125	△	△
L105.5522.2.6	22	1	3.3	5.7	3.7	7	15	30	6	105125	△	△
L105.5528.3.6	28	0.8	3.3	5.7	3.7	7	20	35	6	105125	△	△

Dimensions in mm

P	●	●
M	●	-
K	●	●
N	○	○
S	-	-
H	-	-

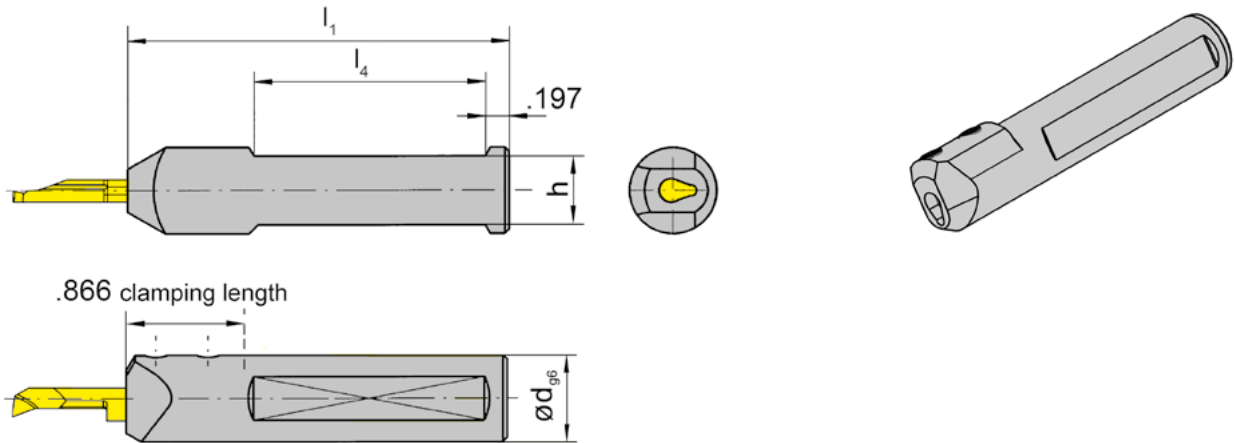
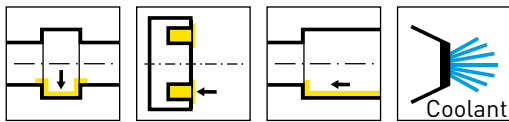

Picture = right hand insert shown

Part number	d	l_1	h	l_4	HWS
BU105.0500.02	.500	3.346	.433	1.969	105225
BU105.0625.02	.625	3.346	.546	1.969	105225
BU105.0750.02	.750	3.937	.671	2.165	105225

Dimensions in inch



Items designated with the 105225 HWS code have extended insert shanks. Inserts and holders with this code must be matched to a corresponding 105225 insert/holder.

Example holder:

Part number	HIS
B105.0012.02	105225

Example insert:

Part number	HIS
R105.1823.4.5.2	105225

Only compatible
with 105225

Spare Parts

Note: setup inserts are located at the end of the chapter

Toolholder	Clamping Screw	TORX PLUS® Wrench	Torque Value
BU105...	6.075T15P	T15PQ	5 Nm

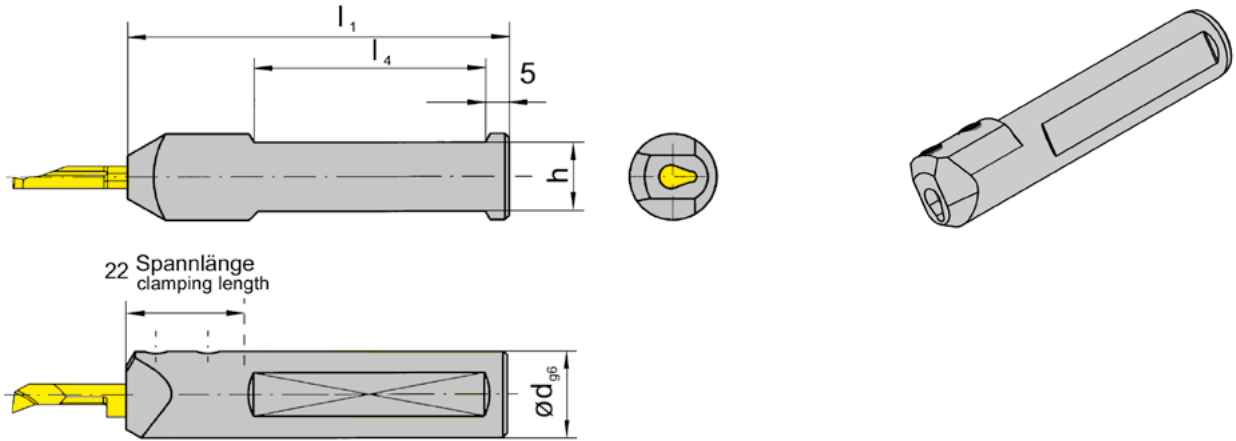
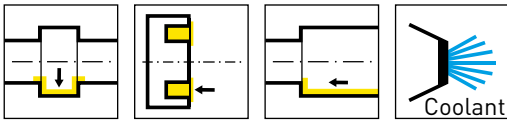

Picture = right hand insert shown

Part number	d	l ₁	h	l ₄	HWS
B105.0012.02	12	85	11	50	105225
B105.0016.02	16	85	14	50	105225
B105.0020.02	20	100	18	55	105225
B105.0022.02	22	100	20	55	105225

Dimensions in mm

Items designated with the 105225 HWS code have extended insert shanks. Inserts and holders with this code must be matched to a corresponding 105225 insert/holder.

Example holder:

Part number	HIS
B105.0012.02	105225

Example insert:

Part number	HIS
R105.1823.4.5.2	105225

Only compatible with 105225

Spare Parts

Note: setup inserts are located at the end of the chapter

Toolholder	Clamping Screw	TORX PLUS® Wrench	Torque Value
B105...	6.075T15P	T15PQ	5 Nm

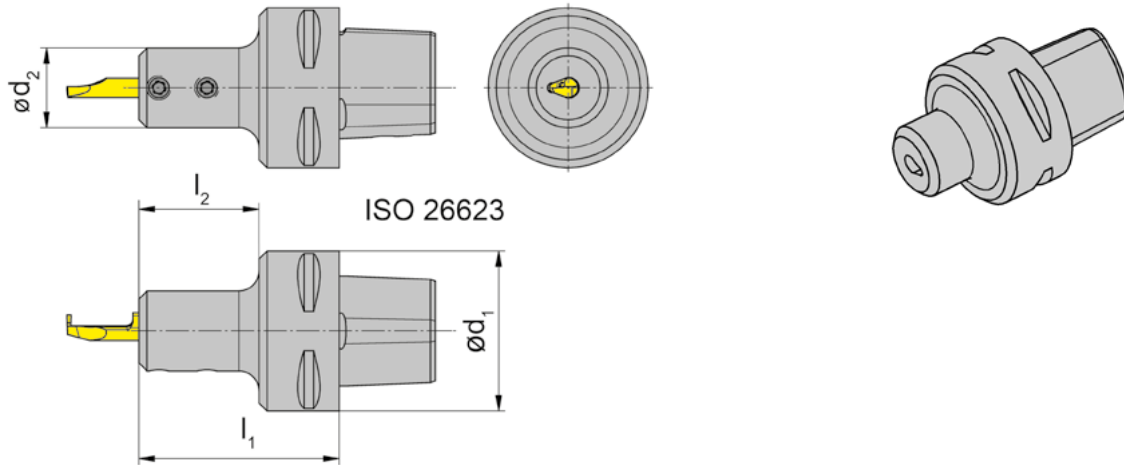
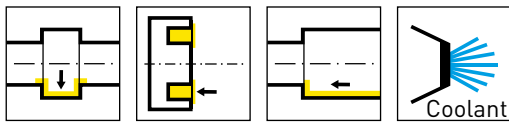

L = left hand version shown

R = right hand version

Part number	d_1	d_2	l_1	l_2	HWS
RB105.00C4.20.1.02	40	20	50	20	105225
RB105.00C6.20.1.02	63	20	52	30	105225
LB105.00C4.20.1.02	40	20	50	20	105225
LB105.00C6.20.1.02	63	20	52	30	105225

Polygonal shanks according to ISO 26623

Dimensions in mm

Items designated with the 105225 HWS code have extended insert shanks. Inserts and holders with this code must be matched to a corresponding 105225 insert/holder.

Example holder:

Part number	HIS
B105.0012.02	105225

Example insert:

Part number	HIS
R105.1823.4.5.2	105225

Only compatible
with 105225

Spare Parts

Note: setup inserts are located at the end of the chapter

Toolholder	Clamping Screw	TORX PLUS® Wrench	Torque Value
R/LB105...	6.075T15P	T15PQ	5 Nm

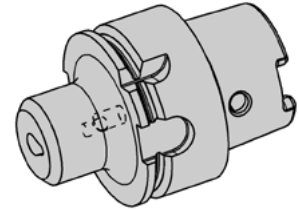
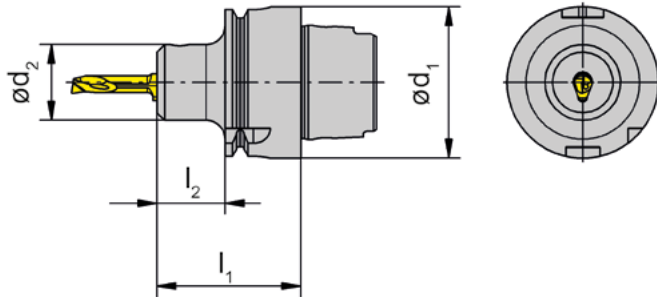
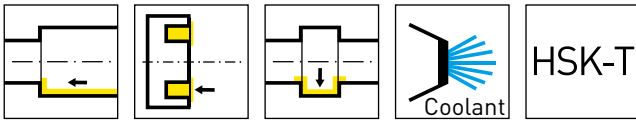

R = right hand version shown

L = left hand version

Part number	d_1	l_1	l_2	d_2	HWS
HSKT40.LB105.20.1.02	40	48	28	20	105225
HSKT40.RB105.20.1.02	40	48	28	20	105225

Dimensions in mm

Items designated with the 105225 HWS code have extended insert shanks. Inserts and holders with this code must be matched to a corresponding 105225 insert/holder.

Example holder:

Part number	HIS
B105.0012.02	105225

Example insert:

Part number	HIS
R105.1823.4.5.2	105225

Only compatible with 105225

Spare Parts

	Clamping Screw	TORX PLUS® Wrench	Torque Value
HSKT40...	6.075T15P	T15PQ	5 Nm

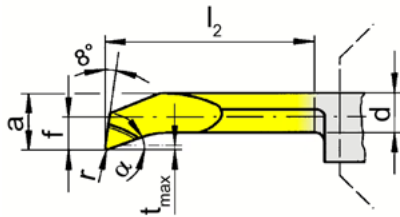
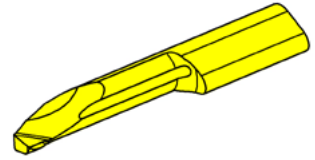
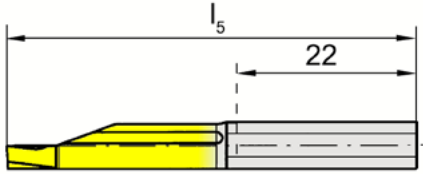
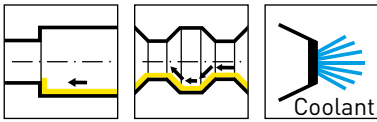

Coating grades

R = right hand version shown

L = left hand version

▲ In stock

△ 2 weeks

Part number	r	f	a	d	b	l ₂	l ₅	t _{max}	D _{min}	α	HIS	EG35	IG35	TF45	TH35	TI25
R105.1823.4.5.2	0.1	2.3	4.7	4.2	7	25	50	0.3	5	21°	105225	△			▲	▲
R105.1823.5.5.2	0.1	2.3	4.7	4.2	7	30	55	0.3	5	21°	105225	△			▲	▲
R105.1833.4.6.2	0.1	3.3	5.7	4.9	7	25	50	0.3	6	21°	105225	△		△	▲	▲
R105.1833.5.6.2	0.1	3.3	5.7	4.9	7	30	55	0.3	6	21°	105225	△			▲	▲
R105.1840.4.7.2	0.1	4	6.4	5.4	7	25	50	0.3	6.8	21°	105225	△			▲	▲
R105.1840.5.7.2	0.1	4	6.4	5.4	7	30	55	0.3	6.8	21°	105225	△			▲	▲
R105.1840.7.7.2	0.1	4	6.4	5.4	7	40	65	0.3	6.8	21°	105225	△	▲			▲
R105.4733.5.6.2	0.1	3.3	5.7	3.7	7	30	55	1.8	6	47°	105225	△			▲	▲
L105.1823.4.5.2	0.1	2.3	4.7	4.2	7	25	50	0.3	5	21°	105225	△			▲	▲
L105.1823.5.5.2	0.1	2.3	4.7	4.2	7	30	55	0.3	5	21°	105225				▲	▲
L105.1833.4.6.2	0.1	3.3	5.7	4.9	7	25	50	0.3	6	21°	105225	△			▲	▲
L105.1833.5.6.2	0.1	3.3	5.7	4.9	7	30	55	0.3	6	21°	105225	△			▲	▲
L105.1840.4.7.2	0.1	4	6.4	5.4	7	25	50	0.3	6.8	21°	105225	△			▲	▲
L105.1840.5.7.2	0.1	4	6.4	5.4	7	30	55	0.3	6.8	21°	105225	△			▲	▲
L105.1840.7.7.2	0.1	4	6.4	5.4	7	40	65	0.3	6.8	21°	105225	△			▲	▲
L105.4733.5.6.2	0.1	3.3	5.7	3.7	7	30	55	1.8	6	47°	105225	△			▲	▲

Dimensions in mm

P	●	●	-	●	●
M	●	●	-	●	●
K	●	●	-	●	-
N	○	○	-	-	●
S	-	○	-	-	-
H	-	-	-	-	-

Items designated with the 105225 HWS code have extended insert shanks. Inserts and holders with this code must be matched to a corresponding 105225 insert/holder.

Example holder:

Part number	HIS
B105.0012.02	105225

Example insert:

Part number	HIS
R105.1823.4.5.2	105225

Only compatible with 105225

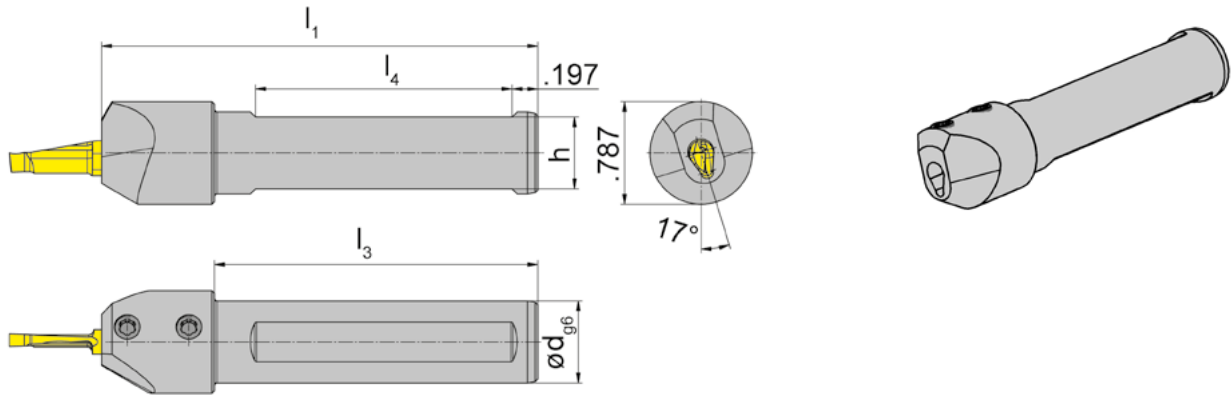
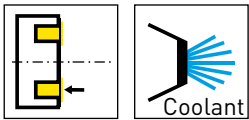

L = left hand version shown

R = right hand version

Part number	d	l ₁	l ₃	h	l ₄	HWS
RBU105.0625.12.2	.625	3.346	2.480	.546	1.969	105225
RBU105.0750.12.2	.750	3.937	-	.671	2.165	105225
RBU105.1000.12.2	1.000	3.937	-	.921	2.165	105225
LBU105.0625.12.2	.625	3.346	2.480	.546	1.969	105225
LBU105.0750.12.2	.750	3.937	-	.671	2.165	105225
LBU105.1000.12.2	1.000	3.937	-	.921	2.165	105225

These holders are rotated/cranked at 17° and are only compatible with the RA/LA inserts on the following pages. The inserts are marked with a note.

Dimensions in inch

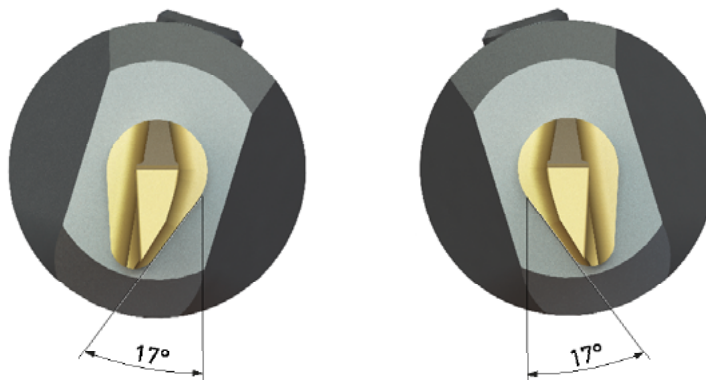

RA105 - RBU105

LA105 - LBU105

Spare Parts

Note: setup inserts are located at the end of the chapter

Toolholder	Clamping Screw	TORX PLUS® Wrench	Torque Value
R/LBU105...	6.075T15P	T15PQ	5 Nm

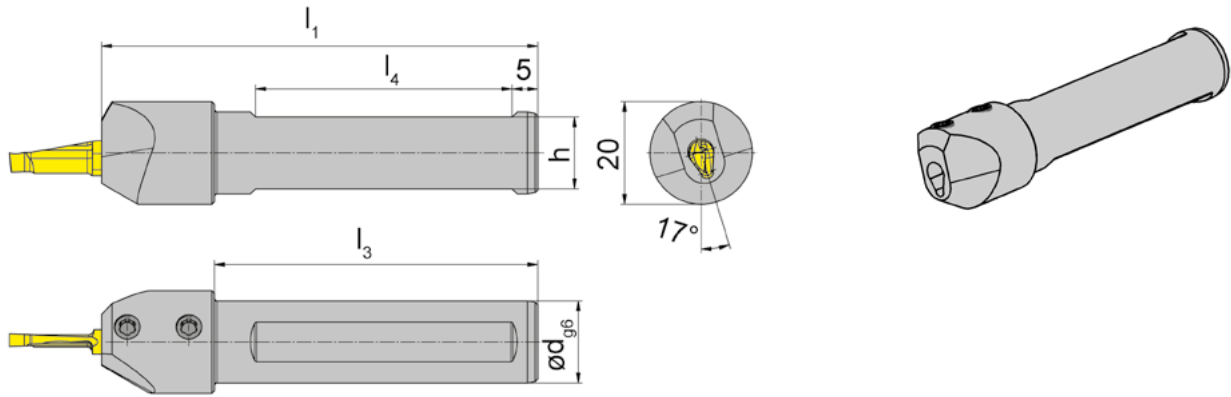
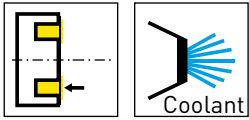

L = left hand version shown

R = right hand version

Part number	d	l_1	l_3	h	l_4	HWS
RB105.0016.12.2	16	85	63	14	50	105225
RB105.0020.12.2	20	100	-	18	55	105225
LB105.0016.12.2	16	85	63	14	50	105225
LB105.0020.12.2	20	100	-	18	55	105225

These holders are rotated/cranked at 17° and are only compatible with the RA/LA inserts on the following pages. The inserts are marked with a note.

Dimensions in mm

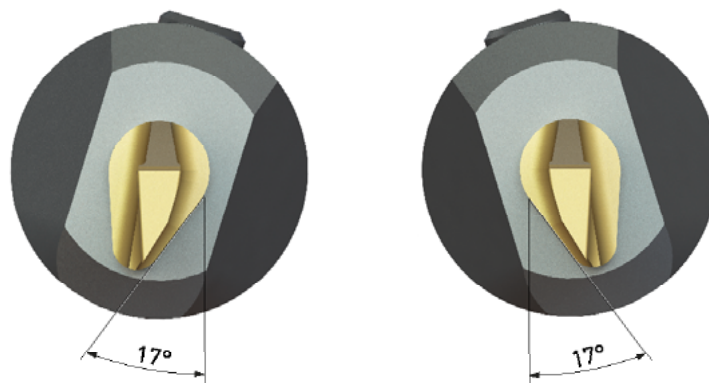

RA105 - RB105

LA105 - LB105

Spare Parts

Note: setup inserts are located at the end of the chapter

Toolholder	Clamping Screw	TORX PLUS® Wrench	Torque Value
R/LB105...	6.075T15P	T15PQ	5 Nm

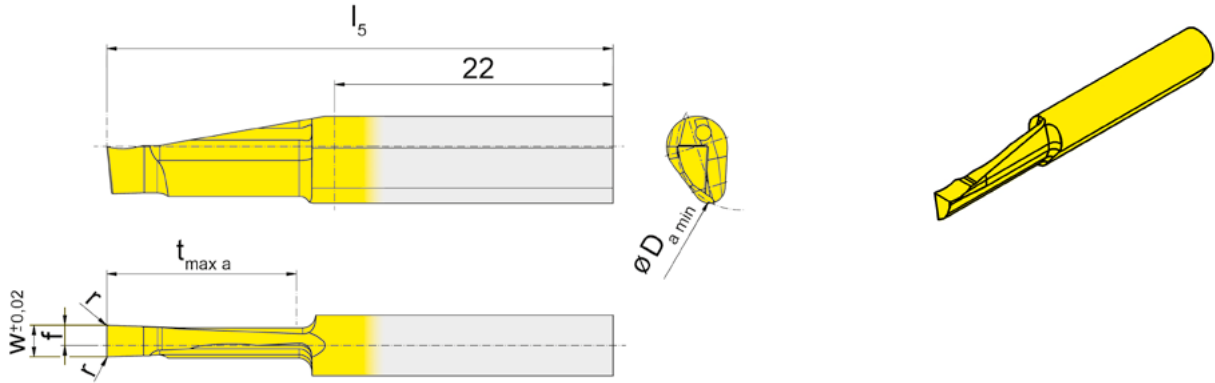
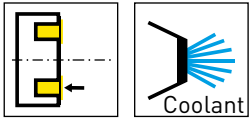

Coating grades

L = left hand version shown

R = right hand version

▲ In stock

△ 2 weeks

Part number	w	r	f	l_5	$t_{\text{max a}}$	$D_{a \text{ min}}$	$D_{a \text{ max}}$	HIS	EG35	TI25
RA105.1020.2.2	2	0.1	1.4	40	15	10	44	105225	▲	▲
RA105.1025.2.2	2.5	0.1	1.6	40	15	10	45	105225	▲	▲
RA105.1030.2.2	3	0.1	1	40	15	10	46	105225	▲	▲
LA105.1020.2.2	2	0.1	1.4	40	15	10	44	105225	▲	▲
LA105.1025.2.2	2.5	0.1	1.6	40	15	10	45	105225	▲	▲
LA105.1030.2.2	3	0.1	1	40	15	10	46	105225	▲	▲

These inserts are rotated at 17° and are only compatible with the holders on the previous pages. The holders are marked with a note.

Face grooving to the full width and full depth can only be performed for diameters between 10-40 mm. Do not exceed 40mm if grooving at full width and depth.

Dimensions in mm

P	●	●
M	●	●
K	●	-
N	○	●
S	-	-
H	-	-

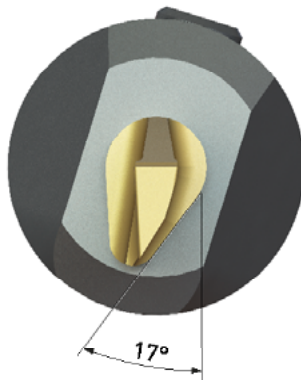

RA105 - RB105

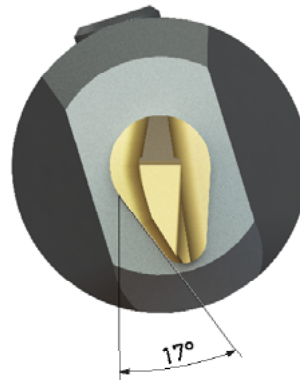

LA105 - LB105

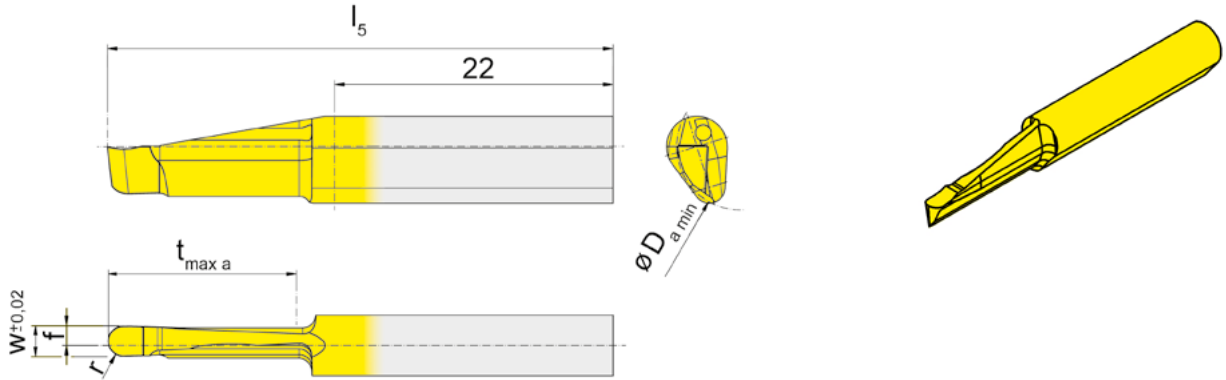
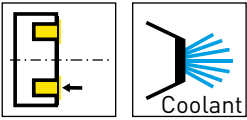

Coating grades

L = left hand version shown

R = right hand version

▲ In stock

△ 2 weeks

Part number	w	r	f	l_5	$t_{max a}$	$D_{a \min}$	$D_{a \max}$	HIS	EG35	TI25
RA105.1020.10.2.2	2	1	1.4	40	15	10	44	105225	▲	▲
RA105.1025.12.2.2	2.5	1.25	1.6	40	15	10	45	105225	△	▲
RA105.1030.15.2.2	3	1.5	1.9	40	15	10	46	105225	▲	▲
LA105.1020.10.2.2	2	1	1.4	40	15	10	44	105225	△	▲
LA105.1025.12.2.2	2.5	1.25	1.6	40	15	10	45	105225	△	△
LA105.1030.15.2.2	3	1.5	1.9	40	15	10	46	105225	△	▲

These inserts are rotated at 17° and are only compatible with the holders on the previous pages. The holders are marked with a note.

Face grooving to the full width and full depth can only be performed for diameters between 10-40 mm. Do not exceed 40mm if grooving at full width and depth.

Dimensions in mm

P	●	●
M	●	●
K	●	-
N	○	●
S	-	-
H	-	-

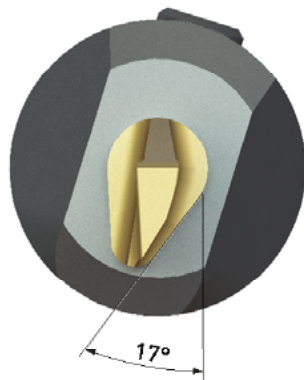

RA105 - RB105

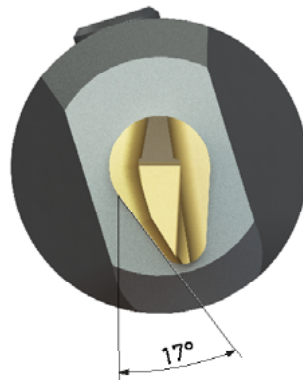

LA105 - LB105

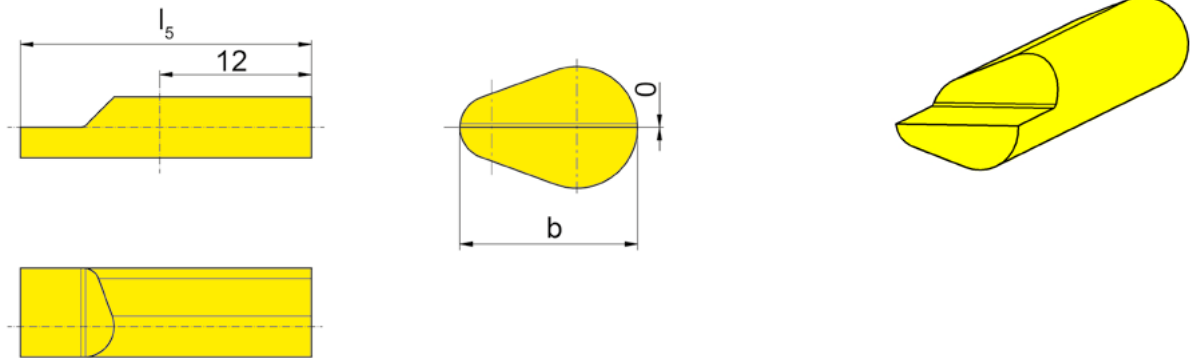
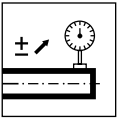

R = right hand version shown

Part number	b	l_5	HIS
R105.LEHR.H.03	5.9	25	105123
R105.LEHR.H.04	6.4	25	105124
R105.LEHR.H.05	7	25	105125

Setup and calibration inserts

Dimensions in mm

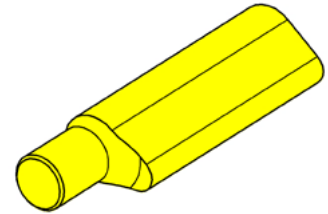
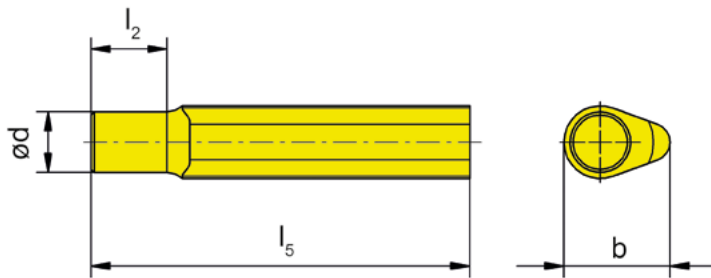
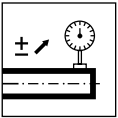

Part number	d	b	l_2	l_5	HIS
105.LEHR.D.03	1.7	5.9	3	25	105123
105.LEHR.D.04	1.7	6.4	3	25	105124
105.LEHR.D.05	4	7	5	25	105125

Setup and calibration inserts

Dimensions in mm

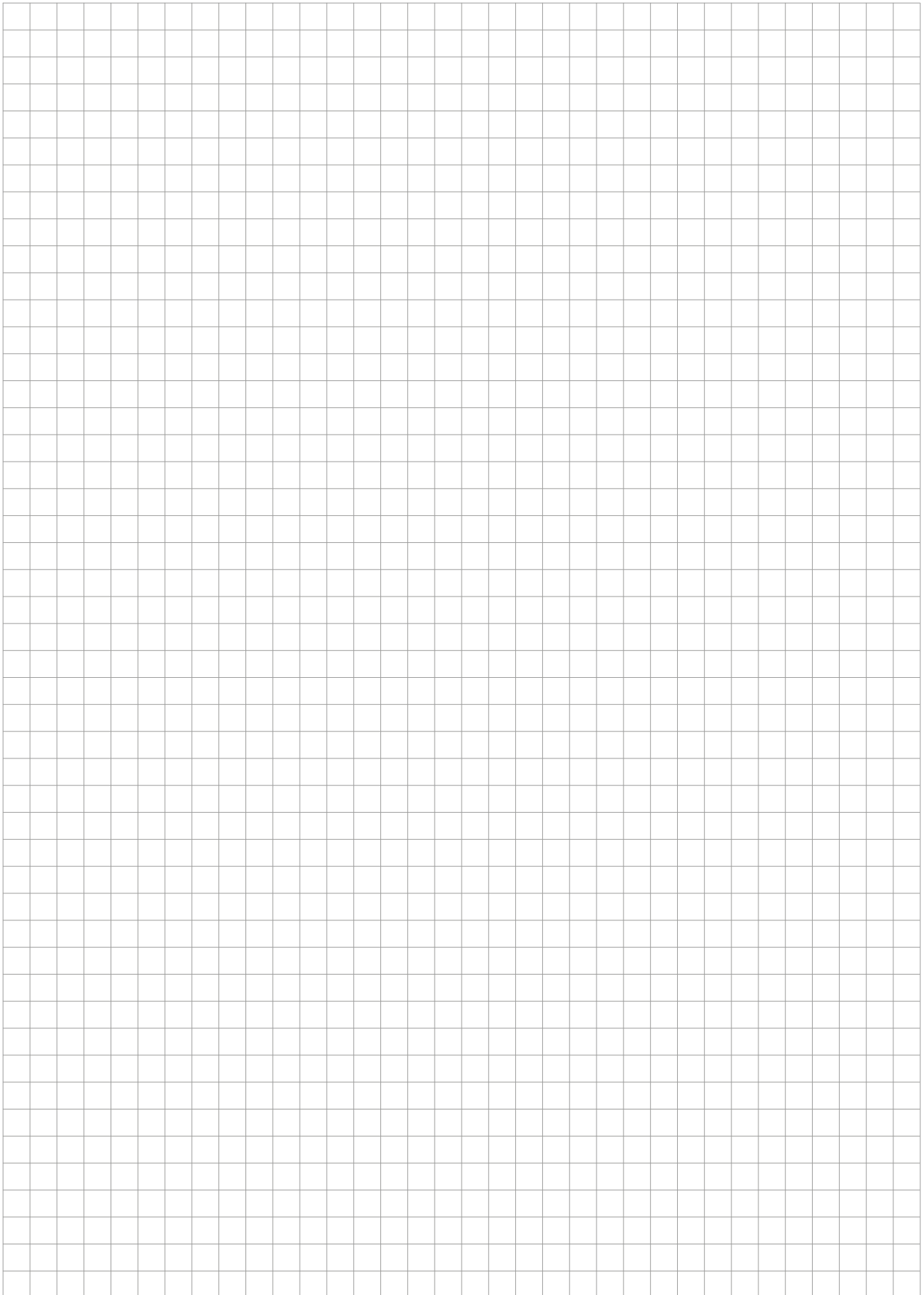

MADE IN THE USA



Scan or click

AMERICAN MANUFACTURING SUPPORTED BY GERMAN ENGINEERING

112,000 ft² manufacturing facility in Franklin, TN.

Local production of standard and special inserts.

In-house HiPIMS coating process.

Scan QR Code for more details.

B





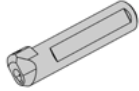
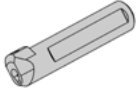

SUPERMINI 109

B

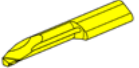
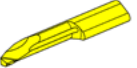
Bore Ø		Tool System											
mm	in	105	109	110	106	107	108	10P	111	11P	114	116	18P
≥ 0.2	≥ .0079	•											
≥ 0.5	≥ .0197	•											
≥ 0.7	≥ .0276	•											
≥ 1.0	≥ .0394	•											
≥ 1.5	≥ .0591	•											
≥ 2.0	≥ .0787	•											
≥ 3.0	≥ .1181	•											
≥ 4.0	≥ .1575	•											
≥ 5.0	≥ .1969	•											
≥ 6.0	≥ .2362	•	•	•	•								
≥ 6.8	≥ .2677		•	•	•								
≥ 7.0	≥ .2756		•			•							
≥ 7.8	≥ .3071			•		•	•						
≥ 8.0	≥ .3150			•		•	•						
≥ 9.0	≥ .3543			•		•	•	•					
≥ 10.0	≥ .3937			•				•	•	•			
≥ 10.5	≥ .4134									•			
≥ 11.0	≥ .4331								•	•			
≥ 11.5	≥ .4528									•			
≥ 13.8	≥ .5433										•		
≥ 14.0	≥ .5512										•	•	
≥ 16.0	≥ .6299									•		•	
≥ 16.5	≥ .6496										[•]		
≥ 18.0	≥ .7087												•
Depth of groove		2.5	2.5	4.0	0.8	2.0	1.0	3.0	2.3	3.5	4.0, [6.5]	4.3	8.0
		.0984	.0984	.1575	.0315	.0787	.0394	.1181	.0906	.1378	.1575, [.2559]	.1693	.3150
Width of groove		0.5-2.0	1.0-2.0	1.0-3.0	0.7-1.5	1.0-2.0	0.7-2.0	1.0-3.0	0.7-3.0	1.0-3.0	0.7-3.0	0.7-4.0	2.0-3.0
		.0197- .0787	.0394- .0787	.0394- .1181	.0276- .0591	.0394- .0787	.0276- .0787	.0394- .1181	.0276- .1181	.0394- .1181	.0276- .1181	.0276- .1575	.0787- .1181
Operations													
Grooving		•	•	•	•	•	•	•	•	•	•	•	•
Boring		•	•	•	•	•	•		•		•	•	
Threading		•	•			•	•		•		•	•	
Chamfering		•	•			•	•		•		•	•	
Face Grooving		•	•	•							•		
Boring and Profiling		•					•	•	•	•	•	•	

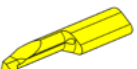
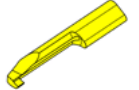
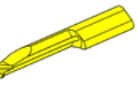
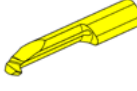
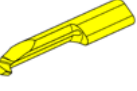
HOLDERS	Round Shank	
	 Page 181 Holder BU109 Inch Shank	 Page 183 Holder B109

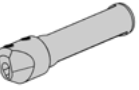
INSERTS	Boring			
	 Page 184-185 Boring	 Page 186-187 Boring .HV Chipbreaker	 Page 188 Back Boring	 Page 189 Chamfering and Profiling
	Grooving		Threading	
	 Page 190-193 Grooving	 Page 194 Grooving Full Radius	 Page 195 Threading, 60° Partial Profile	 Page 196 Threading Trapezoidal

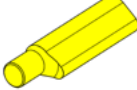
SPECIALTY	Face Grooving		Setup/Calibration	
	 Page 197 Holder B109 Angled seat	 Page 198 Face Grooving Angled neck	 Page 199 Setup/Calibration	 Page 200 Setup/Calibration

B

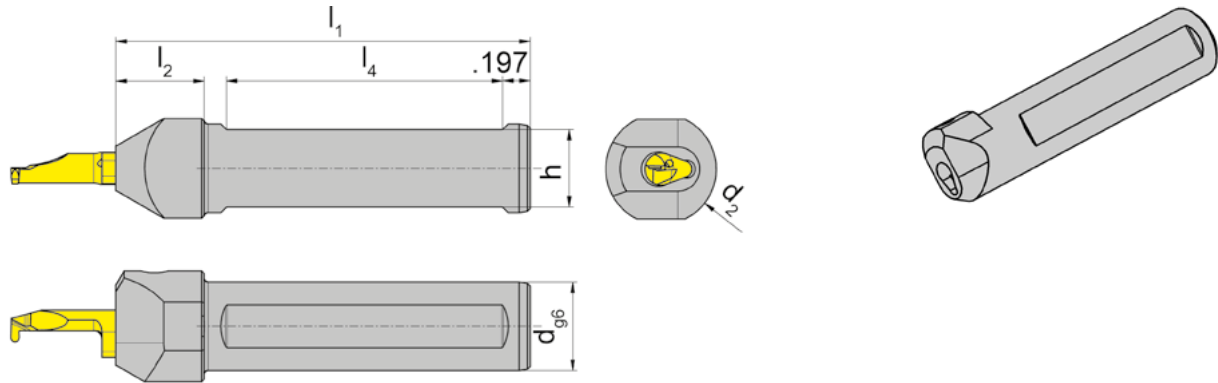
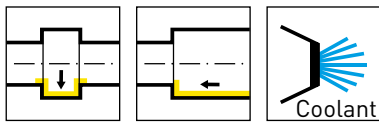

Picture = right hand insert shown

Part number	d	l ₁	h	l ₄	l ₂	d ₂	HWS
BU109.0500.01	.500	2.953	.421	1.969	.630	.750	109140.000
BU109.0625.01	.625	2.953	.546	1.969	.630	.750	109140.000
BU109.0750.01	.750	3.543	.671	2.165	-	-	109140.000
BU109.1000.01	1.000	3.937	.921	2.165	-	-	109140.000

.0750 and .1000 holders do not have an l2 flange

Dimensions in inch



Spare Parts

Note: setup inserts are located at the end of the chapter

Toolholder	Clamping Screw	TORX PLUS® Wrench	Torque Value
BU109...	6.075T15P	T15PQ	5 Nm

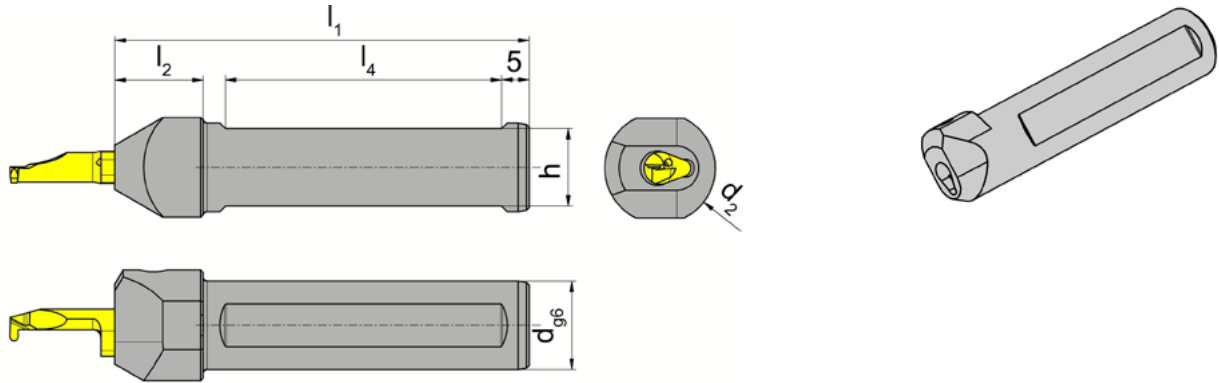
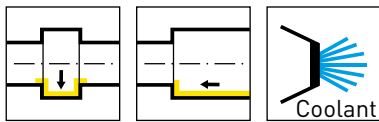

Picture = right hand insert shown

Part number	d	l ₁	h	l ₄	l ₂	d ₂	HWS
B109.0012.01	12	75	10	50	16	20	109140
B109.0016.01	16	75	14	50	16	20	109140
B109.0020.01	20	90	18	55	-	20	109140
B109.0025.01	25	100	23	55	-	25	109140

.0020 and .0025 holders do not have an l2 flange

Dimensions in mm

Spare Parts

Note: setup inserts are located at the end of the chapter

Toolholder	Clamping Screw	TORX PLUS® Wrench	Torque Value
B109...	6.075T15P	T15PQ	5 Nm

B

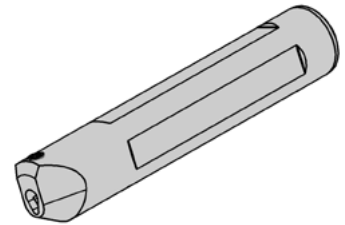
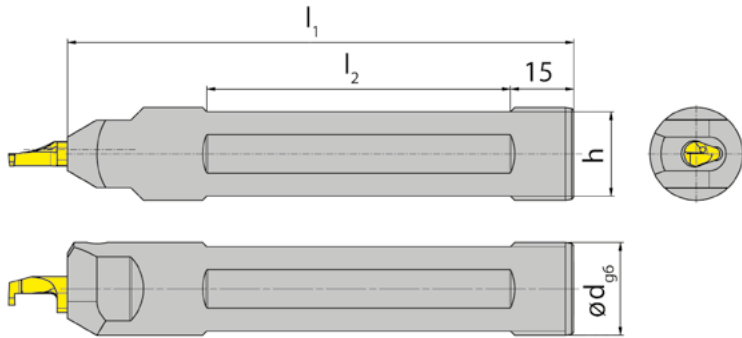
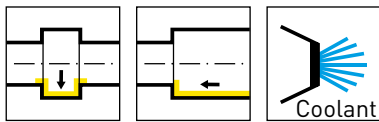

Picture = right hand insert shown

Part number	d	l ₁	h	l ₂	HWS
B109.0022.1.2.01	22	120	20	72	109140

Dimensions in mm

Spare Parts

Note: setup inserts are located at the end of the chapter

Toolholder	Clamping Screw	TORX PLUS® Wrench	Torque Value
B109.0022.1.2.01	6.075T15P	T15PQ	5 Nm

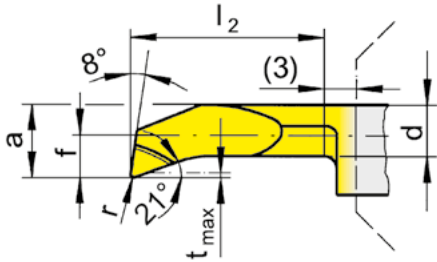
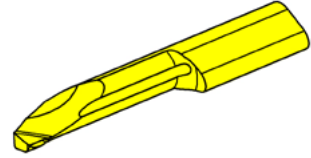
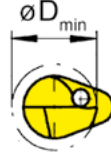
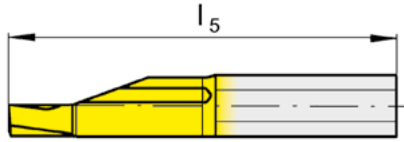
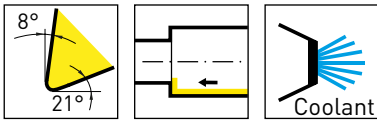

Coating grades

R = right hand version shown

L = left hand version

▲ In stock

Δ 2 weeks

Part number	r	f	a	d	l ₂	l ₅	t _{max}	D _{min}	HIS	TH35
R109.1828.1.6	0.2	2.8	5.7	5	10	28	0.4	6	109140	Δ
R109.1828.2.6	0.2	2.8	5.7	5	15	33	0.4	6	109140	Δ
R109.1828.3.6	0.2	2.8	5.7	5	20	38	0.4	6	109140	▲
R109.1828.4.6	0.2	2.8	5.7	5	25	43	0.4	6	109140	Δ
R109.1828.5.6	0.2	2.8	5.7	5	30	48	0.4	6	109140	Δ
R109.1828.6.6	0.2	2.8	5.7	5	35	53	0.4	6	109140	▲
R109.1828.7.6	0.2	2.8	5.7	5	40	58	0.4	6	109140	▲
R109.1838.2.7	0.2	3.8	6.7	6	15	33	0.4	7	109140	Δ
R109.1838.3.7	0.2	3.8	6.7	6	20	38	0.4	7	109140	Δ
R109.1838.4.7	0.2	3.8	6.7	6	25	43	0.4	7	109140	Δ
R109.1838.5.7	0.2	3.8	6.7	6	30	48	0.4	7	109140	▲
R109.1838.6.7	0.2	3.8	6.7	6	35	53	0.4	7	109140	▲
R109.1838.7.7	0.2	3.8	6.7	6	40	58	0.4	7	109140	▲
R109.1838.8.7	0.2	3.8	6.7	6	45	63	0.4	7	109140	▲
L109.1828.1.6	0.2	2.8	5.7	5	10	28	0.4	6	109140	Δ
L109.1828.2.6	0.2	2.8	5.7	5	15	33	0.4	6	109140	Δ
L109.1828.3.6	0.2	2.8	5.7	5	20	38	0.4	6	109140	Δ
L109.1828.5.6	0.2	2.8	5.7	5	30	48	0.4	6	109140	Δ
L109.1828.6.6	0.2	2.8	5.7	5	35	53	0.4	6	109140	Δ
L109.1828.7.6	0.2	2.8	5.7	5	40	58	0.4	6	109140	Δ
L109.1838.2.7	0.2	3.8	6.7	6	15	33	0.4	7	109140	Δ
L109.1838.3.7	0.2	3.8	6.7	6	20	38	0.4	7	109140	Δ
L109.1838.4.7	0.2	3.8	6.7	6	25	43	0.4	7	109140	Δ
L109.1838.5.7	0.2	3.8	6.7	6	30	48	0.4	7	109140	Δ
L109.1838.6.7	0.2	3.8	6.7	6	35	53	0.4	7	109140	Δ
L109.1838.7.7	0.2	3.8	6.7	6	40	58	0.4	7	109140	Δ
L109.1838.8.7	0.2	3.8	6.7	6	45	63	0.4	7	109140	Δ

Dimensions in mm

P	●
M	●
K	●
N	-
S	-
H	-

B

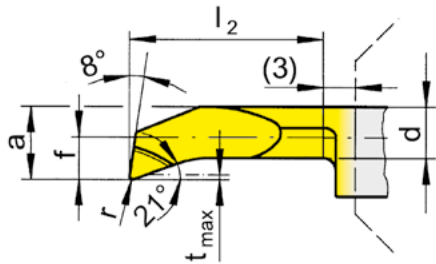
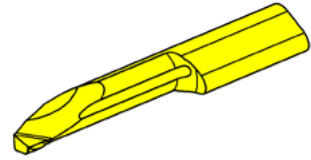
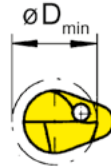
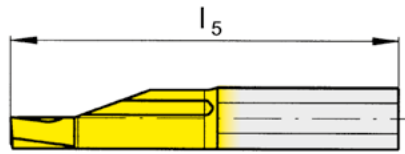
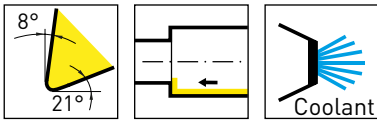

Coating grades

R = right hand version shown

L = left hand version

▲ In stock

Δ 2 weeks

Part number	r	f	a	d	l_2	l_5	t_{max}	D_{min}	HIS	TH35
R109.1828.04.1.6	0.4	2.8	5.7	5	10	28	0.4	6	109140	Δ
R109.1828.04.2.6	0.4	2.8	5.7	5	15	33	0.4	6	109140	Δ
R109.1828.04.3.6	0.4	2.8	5.7	5	20	38	0.4	6	109140	Δ
R109.1828.04.4.6	0.4	2.8	5.7	5	25	43	0.4	6	109140	Δ
R109.1828.04.5.6	0.4	2.8	5.7	5	30	48	0.4	6	109140	Δ
R109.1828.04.6.6	0.4	2.8	5.7	5	35	53	0.4	6	109140	Δ
R109.1838.04.6.7	0.4	3.8	6.7	6	35	53	0.4	7	109140	Δ
R109.1828.04.7.6	0.4	2.8	5.7	5	40	58	0.4	6	109140	Δ
R109.1838.04.2.7	0.4	3.8	6.7	6	15	33	0.4	7	109140	Δ
R109.1838.04.3.7	0.4	3.8	6.7	6	20	38	0.4	7	109140	Δ
R109.1838.04.4.7	0.4	3.8	6.7	6	25	43	0.4	7	109140	Δ
R109.1838.04.5.7	0.4	3.8	6.7	6	30	48	0.4	7	109140	Δ
R109.1838.04.7.7	0.4	3.8	6.7	6	40	58	0.4	7	109140	▲
R109.1838.04.8.7	0.4	3.8	6.7	6	45	63	0.4	7	109140	▲
L109.1828.04.1.6	0.4	2.8	5.7	5	10	28	0.4	6	109140	Δ
L109.1828.04.2.6	0.4	2.8	5.7	5	15	33	0.4	6	109140	Δ
L109.1828.04.3.6	0.4	2.8	5.7	5	20	38	0.4	6	109140	Δ
L109.1828.04.4.6	0.4	2.8	5.7	5	25	43	0.4	6	109140	Δ
L109.1828.04.6.6	0.4	2.8	5.7	5	35	53	0.4	6	109140	Δ
L109.1828.04.7.6	0.4	2.8	5.7	5	40	58	0.4	6	109140	Δ
L109.1838.04.2.7	0.4	3.8	6.7	6	15	33	0.4	7	109140	Δ
L109.1838.04.3.7	0.4	3.8	6.7	6	20	38	0.4	7	109140	Δ
L109.1838.04.8.7	0.4	3.8	6.7	6	45	63	0.4	7	109140	Δ

Dimensions in mm

P	●
M	●
K	●
N	-
S	-
H	-

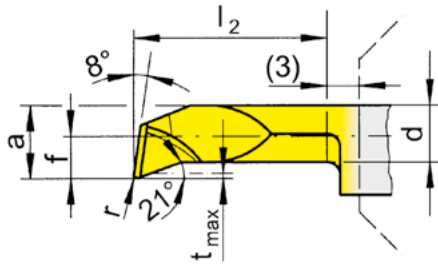
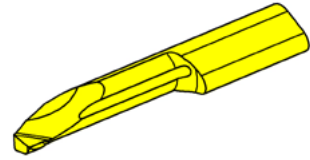
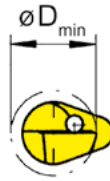
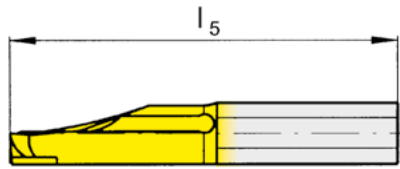
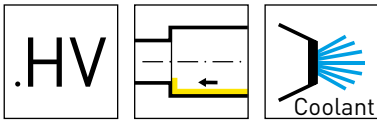

Coating grades

R = right hand version shown

L = left hand version

▲ In stock

△ 2 weeks

Part number	r	f	a	d	l ₂	l ₅	t _{max}	D _{min}	HIS	TH35
R109.1828.1.HV6	0.2	2.8	5.7	5	10	28	0.4	6	109140	△
R109.1828.2.HV6	0.2	2.8	5.7	5	15	33	0.4	6	109140	△
R109.1828.3.HV6	0.2	2.8	5.7	5	20	38	0.4	6	109140	▲
R109.1828.4.HV6	0.2	2.8	5.7	5	25	43	0.4	6	109140	△
R109.1828.5.HV6	0.2	2.8	5.7	5	30	48	0.4	6	109140	▲
R109.1828.6.HV6	0.2	2.8	5.7	5	35	53	0.4	6	109140	▲
R109.1828.7.HV6	0.2	2.8	5.7	5	40	58	0.4	6	109140	▲
R109.1838.3.HV7	0.2	3.8	6.7	6	20	38	0.4	7	109140	△
R109.1838.4.HV7	0.2	3.8	6.7	6	25	43	0.4	7	109140	△
R109.1838.5.HV7	0.2	3.8	6.7	6	30	48	0.4	7	109140	△
R109.1838.6.HV7	0.2	3.8	6.7	6	35	53	0.4	7	109140	△
R109.1838.7.HV7	0.2	3.8	6.7	6	40	58	0.4	7	109140	△
R109.1838.8.HV7	0.2	3.8	6.7	6	45	63	0.4	7	109140	▲
L109.1828.1.HV6	0.2	2.8	5.7	5	10	28	0.4	6	109140	△
L109.1828.2.HV6	0.2	2.8	5.7	5	15	33	0.4	6	109140	△
L109.1828.3.HV6	0.2	2.8	5.7	5	20	38	0.4	6	109140	△
L109.1828.4.HV6	0.2	2.8	5.7	5	25	43	0.4	6	109140	△
L109.1828.6.HV6	0.2	2.8	5.7	5	35	53	0.4	6	109140	△
L109.1828.7.HV6	0.2	2.8	5.7	5	40	58	0.4	6	109140	△
L109.1838.2.HV7	0.2	3.8	6.7	6	15	33	0.4	7	109140	△
L109.1838.5.HV7	0.2	3.8	6.7	6	30	48	0.4	7	109140	△
L109.1838.6.HV7	0.2	3.8	6.7	6	35	53	0.4	7	109140	△
L109.1838.7.HV7	0.2	3.8	6.7	6	40	58	0.4	7	109140	△
L109.1838.8.HV7	0.2	3.8	6.7	6	45	63	0.4	7	109140	△

Dimensions in mm

P	●
M	●
K	●
N	-
S	-
H	-

B

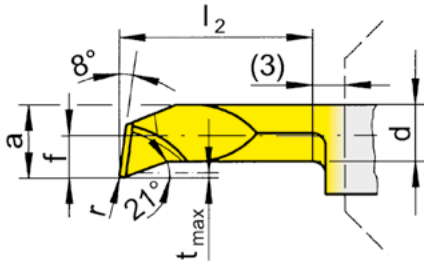
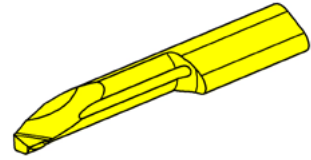
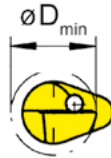
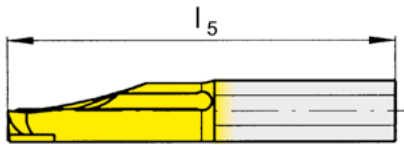
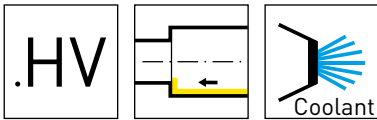

Coating grades

R = right hand version shown

L = left hand version

▲ In stock

Δ 2 weeks

Part number	r	f	a	d	l_2	l_5	t_{max}	D_{min}	HIS	TH35
R109.1828.04.1.HV6	0.4	2.8	5.7	5	10	28	0.4	6	109140	Δ
R109.1828.04.3.HV6	0.4	2.8	5.7	5	20	38	0.4	6	109140	Δ
R109.1828.04.4.HV6	0.4	2.8	5.7	5	25	43	0.4	6	109140	Δ
R109.1828.04.5.HV6	0.4	2.8	5.7	5	30	48	0.4	6	109140	Δ
R109.1828.04.7.HV6	0.4	2.8	5.7	5	40	58	0.4	6	109140	Δ
R109.1838.04.2.HV7	0.4	3.8	6.7	6	15	33	0.4	7	109140	Δ
R109.1838.04.3.HV7	0.4	3.8	6.7	6	20	38	0.4	7	109140	Δ
R109.1838.04.4.HV7	0.4	3.8	6.7	6	25	43	0.4	7	109140	Δ
R109.1838.04.5.HV7	0.4	3.8	6.7	6	30	48	0.4	7	109140	Δ
R109.1838.04.6.HV7	0.4	3.8	6.7	6	35	53	0.4	7	109140	Δ
R109.1838.04.7.HV7	0.4	3.8	6.7	6	40	58	0.4	7	109140	Δ
R109.1838.04.8.HV7	0.4	3.8	6.7	6	45	63	0.4	7	109140	▲
L109.1828.04.1.HV6	0.4	2.8	5.7	5	10	28	0.4	6	109140	Δ
L109.1828.04.4.HV6	0.4	2.8	5.7	5	25	43	0.4	6	109140	Δ
L109.1828.04.5.HV6	0.4	2.8	5.7	5	30	48	0.4	6	109140	Δ
L109.1828.04.7.HV6	0.4	2.8	5.7	5	40	58	0.4	6	109140	Δ
L109.1838.04.2.HV7	0.4	3.8	6.7	6	15	33	0.4	7	109140	Δ
L109.1838.04.3.HV7	0.4	3.8	6.7	6	20	38	0.4	7	109140	Δ
L109.1838.04.4.HV7	0.4	3.8	6.7	6	25	43	0.4	7	109140	Δ
L109.1838.04.5.HV7	0.4	3.8	6.7	6	30	48	0.4	7	109140	Δ
L109.1838.04.6.HV7	0.4	3.8	6.7	6	35	53	0.4	7	109140	Δ
L109.1838.04.7.HV7	0.4	3.8	6.7	6	40	58	0.4	7	109140	Δ

Dimensions in mm

P	●
M	●
K	●
N	-
S	-
H	-

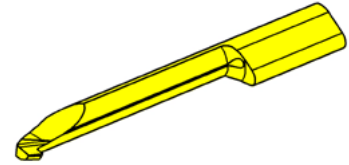
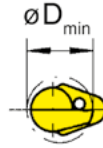
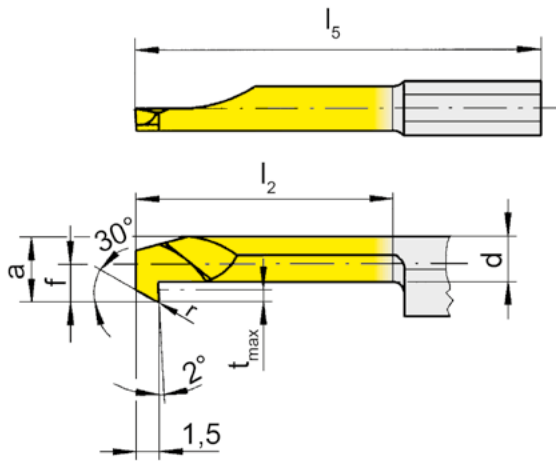
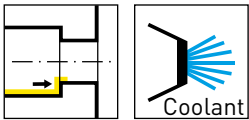

Coating grades

R = right hand version shown

L = left hand version

▲ In stock

Δ 2 weeks

Part number	r	f	a	d	l_2	l_5	t_{max}	D_{min}	HIS	TH35
R109.3028.3.6	0.2	2.8	5.7	3.7	20	38	1.8	6	109140	Δ
R109.3028.5.6	0.2	2.8	5.7	3.7	30	48	1.8	6	109140	Δ
R109.3038.3.7	0.2	3.8	6.7	4	20	38	2.5	7	109140	▲
R109.3038.5.7	0.2	3.8	6.7	4	30	48	2.5	7	109140	▲
L109.3028.3.6	0.2	2.8	5.7	3.7	20	38	1.8	6	109140	Δ
L109.3028.5.6	0.2	2.8	5.7	3.7	30	48	1.8	6	109140	Δ
L109.3038.3.7	0.2	3.8	6.7	4	20	38	2.5	7	109140	Δ

Dimensions in mm

P	●
M	●
K	●
N	-
S	-
H	-

B

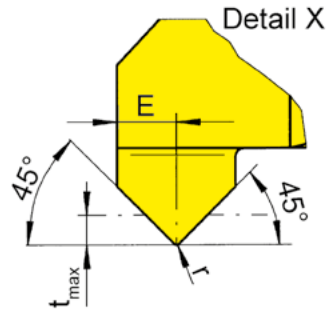
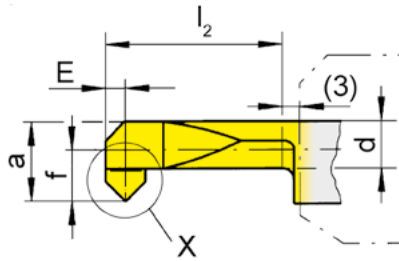
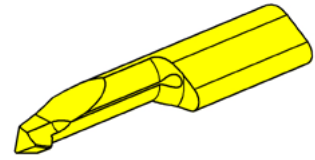
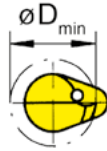
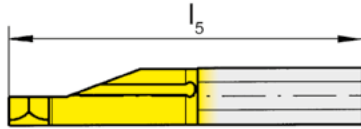
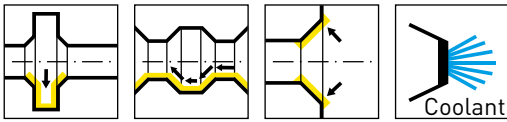

Coating grades

R = right hand version shown

L = left hand version

▲ In stock

Δ 2 weeks

Part number	r	f	E	a	d	l ₂	l ₅	t _{max}	D _{min}	HIS	TH35
R109.4545.3.6	0.2	2.8	1.2	5.7	4.3	20	38	0.9	6	109140	Δ
R109.4545.5.7	0.2	3.8	1.2	6.7	5.3	30	48	0.9	7	109140	▲
L109.4545.3.6	0.2	2.8	1.2	5.7	4.3	20	38	0.9	6	109140	Δ
L109.4545.5.7	0.2	3.8	1.2	6.7	5.3	30	48	0.9	7	109140	Δ

Dimensions in mm

P	●
M	●
K	●
N	-
S	-
H	-

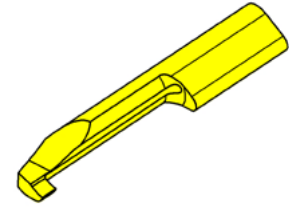
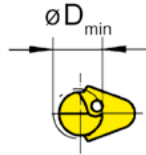
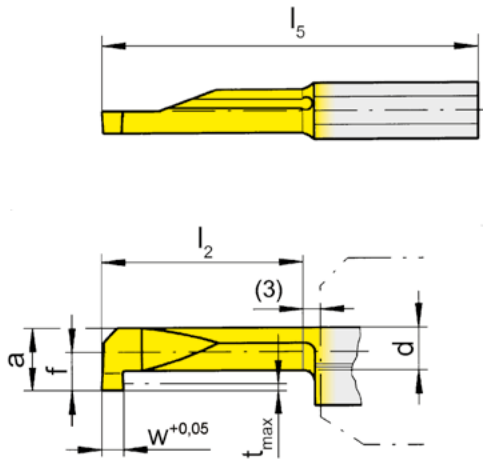
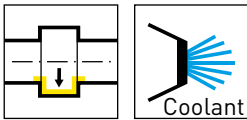

Coating grades

R = right hand version shown

L = left hand version

▲ In stock

Δ 2 weeks

Part number	w	f	a	d	l_2	l_5	t_{max}	D_{min}	HIS	TH35
R109.0100.1.6	1	2.8	5.7	3.7	10	28	1.8	6	109140	Δ
R109.0100.2.6	1	2.8	5.7	3.7	15	33	1.8	6	109140	Δ
R109.0100.3.6	1	2.8	5.7	3.7	20	38	1.8	6	109140	Δ
R109.0100.4.6	1	2.8	5.7	3.7	25	43	1.8	6	109140	Δ
R109.0100.5.6	1	2.8	5.7	3.7	30	48	1.8	6	109140	Δ
R109.0100.6.6	1	2.8	5.7	3.7	35	53	1.8	6	109140	Δ
R109.0150.1.6	1.5	2.8	5.7	3.7	10	28	1.8	6	109140	Δ
R109.0150.2.6	1.5	2.8	5.7	3.7	15	33	1.8	6	109140	Δ
R109.0150.3.6	1.5	2.8	5.7	3.7	20	38	1.8	6	109140	Δ
L109.0100.1.6	1	2.8	5.7	3.7	10	28	1.8	6	109140	Δ
L109.0100.2.6	1	2.8	5.7	3.7	15	33	1.8	6	109140	Δ
L109.0100.3.6	1	2.8	5.7	3.7	20	38	1.8	6	109140	Δ
L109.0100.4.6	1	2.8	5.7	3.7	25	43	1.8	6	109140	Δ
L109.0100.5.6	1	2.8	5.7	3.7	30	48	1.8	6	109140	Δ
L109.0100.6.6	1	2.8	5.7	3.7	35	53	1.8	6	109140	Δ
L109.0150.1.6	1.5	2.8	5.7	3.7	10	28	1.8	6	109140	Δ
L109.0150.2.6	1.5	2.8	5.7	3.7	15	33	1.8	6	109140	Δ
L109.0150.3.6	1.5	2.8	5.7	3.7	20	38	1.8	6	109140	Δ

Dimensions in mm

P	●
M	●
K	●
N	-
S	-
H	-

B

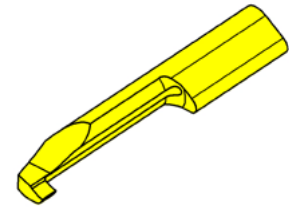
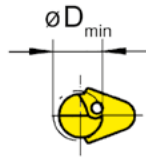
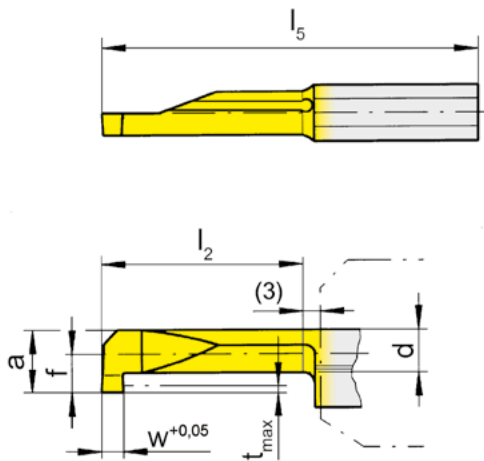
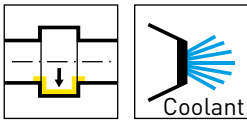

Coating grades

R = right hand version shown

L = left hand version

▲ In stock

Δ 2 weeks

Part number	w	f	a	d	l ₂	l ₅	t _{max}	D _{min}	HIS	TH35
R109.0150.4.6	1.5	2.8	5.7	3.7	25	43	1.8	6	109140	Δ
R109.0150.5.6	1.5	2.8	5.7	3.7	30	48	1.8	6	109140	Δ
R109.0150.6.6	1.5	2.8	5.7	3.7	35	53	1.8	6	109140	▲
R109.0200.1.6	2	2.8	5.7	3.7	10	28	1.8	6	109140	Δ
R109.0200.2.6	2	2.8	5.7	3.7	15	33	1.8	6	109140	Δ
R109.0200.3.6	2	2.8	5.7	3.7	20	38	1.8	6	109140	Δ
R109.0200.4.6	2	2.8	5.7	3.7	25	43	1.8	6	109140	Δ
R109.0200.5.6	2	2.8	5.7	3.7	30	48	1.8	6	109140	Δ
R109.0200.6.6	2	2.8	5.7	3.7	35	53	1.8	6	109140	▲
L109.0150.6.6	1.5	2.8	5.7	3.7	35	53	1.8	6	109140	Δ
L109.0200.1.6	2	2.8	5.7	3.7	10	28	1.8	6	109140	Δ
L109.0200.2.6	2	2.8	5.7	3.7	15	33	1.8	6	109140	Δ
L109.0200.3.6	2	2.8	5.7	3.7	20	38	1.8	6	109140	Δ
L109.0200.4.6	2	2.8	5.7	3.7	25	43	1.8	6	109140	Δ
L109.0200.6.6	2	2.8	5.7	3.7	35	53	1.8	6	109140	Δ

Dimensions in mm

P	●
M	●
K	●
N	-
S	-
H	-

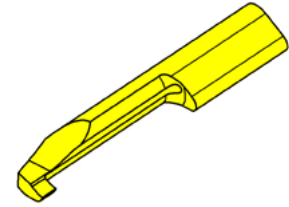
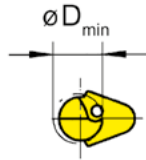
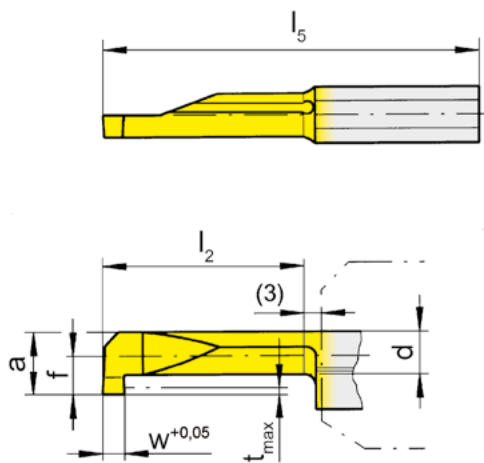
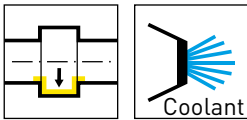

Coating grades

R = right hand version shown

L = left hand version

▲ In stock

Δ 2 weeks

Part number	w	f	a	d	l ₂	l ₅	t _{max}	D _{min}	HIS	TH35
R109.0100.1.7	1	3.8	6.7	4	10	28	2.5	7	109140	Δ
R109.0100.2.7	1	3.8	6.7	4	15	33	2.5	7	109140	Δ
R109.0100.3.7	1	3.8	6.7	4	20	38	2.5	7	109140	Δ
R109.0150.1.7	1.5	3.8	6.7	4	10	28	2.5	7	109140	Δ
R109.0150.2.7	1.5	3.8	6.7	4	15	33	2.5	7	109140	▲
R109.0150.3.7	1.5	3.8	6.7	4	20	38	2.5	7	109140	Δ
R109.0200.1.7	2	3.8	6.7	4	10	28	2.5	7	109140	▲
R109.0200.2.7	2	3.8	6.7	4	15	33	2.5	7	109140	▲
R109.0200.3.7	2	3.8	6.7	4	20	38	2.5	7	109140	Δ
L109.0100.1.7	1	3.8	6.7	4	10	28	2.5	7	109140	Δ
L109.0100.2.7	1	3.8	6.7	4	15	33	2.5	7	109140	Δ
L109.0100.3.7	1	3.8	6.7	4	20	38	2.5	7	109140	Δ
L109.0150.1.7	1.5	3.8	6.7	4	10	28	2.5	7	109140	Δ
L109.0150.2.7	1.5	3.8	6.7	4	15	33	2.5	7	109140	Δ
L109.0200.1.7	2	3.8	6.7	4	10	28	2.5	7	109140	Δ
L109.0200.2.7	2	3.8	6.7	4	15	33	2.5	7	109140	Δ
L109.0200.3.7	2	3.8	6.7	4	20	38	2.5	7	109140	Δ

Dimensions in mm

P	●
M	●
K	●
N	-
S	-
H	-

B

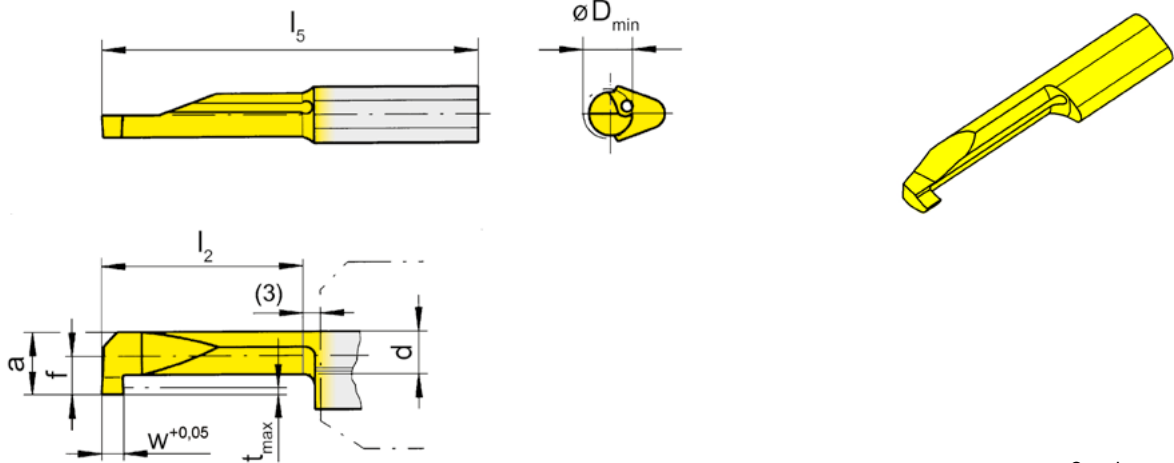
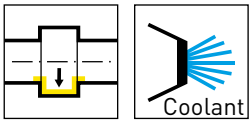

Coating grades

R = right hand version shown

L = left hand version

▲ In stock

Δ 2 weeks

Part number	w	f	a	d	l_2	l_5	t_{max}	D_{min}	HIS	TH35
R109.0150.4.7	1.5	3.8	6.7	4	25	43	2.5	7	109140	Δ
R109.0150.5.7	1.5	3.8	6.7	4	30	48	2.5	7	109140	Δ
R109.0150.6.7	1.5	3.8	6.7	4	35	53	2.5	7	109140	Δ
R109.0200.1.7	2	3.8	6.7	4	10	28	2.5	7	109140	▲
R109.0200.4.7	2	3.8	6.7	4	25	43	2.5	7	109140	Δ
R109.0200.5.7	2	3.8	6.7	4	30	48	2.5	7	109140	▲
R109.0200.6.7	2	3.8	6.7	4	35	53	2.5	7	109140	▲
R109.0100.4.7	1	3.8	6.7	4	25	43	2.5	7	109140	Δ
R109.0100.5.7	1	3.8	6.7	4	30	48	2.5	7	109140	Δ
R109.0100.6.7	1	3.8	6.7	4	35	53	2.5	7	109140	Δ
L109.0150.4.7	1.5	3.8	6.7	4	25	43	2.5	7	109140	Δ
L109.0150.5.7	1.5	3.8	6.7	4	30	48	2.5	7	109140	Δ
L109.0150.6.7	1.5	3.8	6.7	4	35	53	2.5	7	109140	Δ
L109.0200.1.7	2	3.8	6.7	4	10	28	2.5	7	109140	Δ
L109.0200.4.7	2	3.8	6.7	4	25	43	2.5	7	109140	Δ
L109.0200.5.7	2	3.8	6.7	4	30	48	2.5	7	109140	Δ
L109.0200.6.7	2	3.8	6.7	4	35	53	2.5	7	109140	Δ
L109.0100.4.7	1	3.8	6.7	4	25	43	2.5	7	109140	Δ
L109.0100.6.7	1	3.8	6.7	4	35	53	2.5	7	109140	Δ

Dimensions in mm

P	●
M	●
K	●
N	-
S	-
H	-

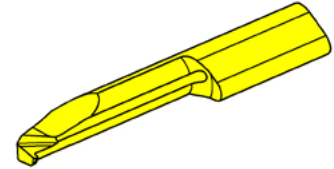
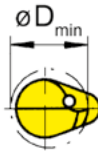
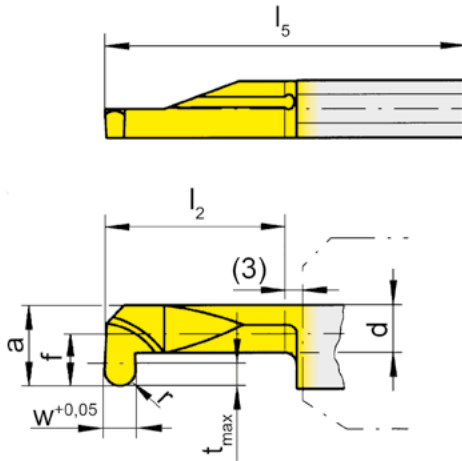
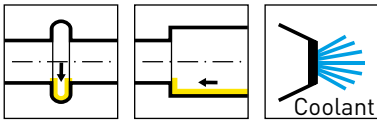

Coating grades

R = right hand version shown

L = left hand version

▲ In stock

Δ 2 weeks

Part number	w	r	f	a	d	l_2	l_5	t_{max}	D_{min}	HIS	TH35
R109.0005.4.6	1	0.5	2.8	5.7	3.7	25	43	1.8	6	109140	Δ
R109.0005.6.7	1	0.5	3.8	6.7	4	35	53	2.5	7	109140	▲
R109.0007.4.6	1.5	0.75	2.8	5.7	3.7	25	43	1.8	6	109140	Δ
R109.0007.6.7	1.5	0.75	3.8	6.7	4	35	53	2.5	7	109140	Δ
R109.0010.4.6	2	1	2.8	5.7	3.7	25	43	1.8	6	109140	Δ
R109.0010.6.7	2	1	3.8	6.7	4	35	53	2.5	7	109140	▲
L109.0005.4.6	1	0.5	2.8	5.7	3.7	25	43	1.8	6	109140	Δ
L109.0005.6.7	1	0.5	3.8	6.7	4	35	53	2.5	7	109140	Δ
L109.0007.4.6	1.5	0.75	2.8	5.7	3.7	25	43	1.8	6	109140	Δ
L109.0007.6.7	1.5	0.75	3.8	6.7	4	35	53	2.5	7	109140	Δ
L109.0010.4.6	2	1	2.8	5.7	3.7	25	43	1.8	6	109140	Δ
L109.0010.6.7	2	1	3.8	6.7	4	35	53	2.5	7	109140	Δ

Dimensions in mm

P	●
M	●
K	●
N	-
S	-
H	-

B

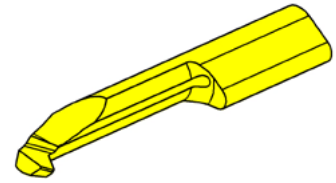
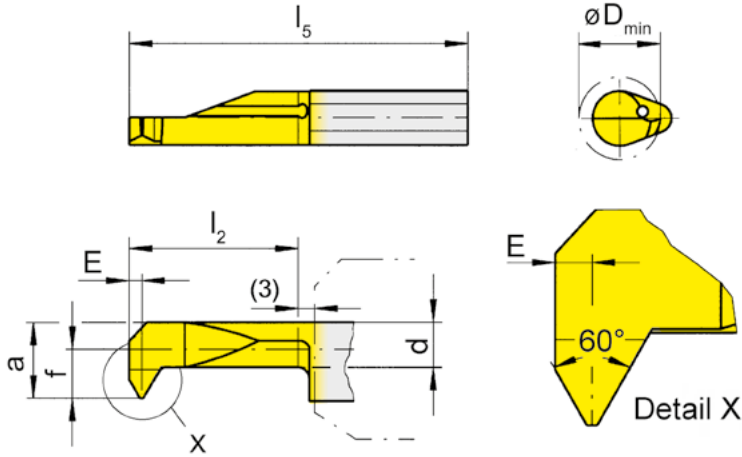
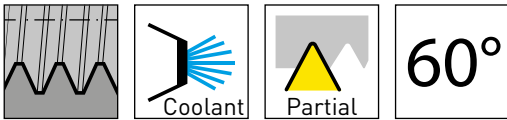

Coating grades

R = right hand version shown

L = left hand version

▲ In stock

Δ 2 weeks

Part number	P	TPI	TPI _{max}	E	f	a	d	l ₂	l ₅	D _{min}	HIS	TH35
R109.0815.1.7	1.5	16	24	0.9	3.8	6.7	5.1	10	28	7	109140	Δ
R109.0815.3.7	1.5	16	24	0.9	3.8	6.7	5.1	20	38	7	109140	Δ
R109.0815.5.7	1.5	16	24	0.9	3.8	6.7	5.1	30	48	7	109140	▲
L109.0815.1.7	1.5	16	24	0.9	3.8	6.7	5.1	10	28	7	109140	Δ
L109.0815.3.7	1.5	16	24	0.9	3.8	6.7	5.1	20	38	7	109140	Δ
L109.0815.5.7	1.5	16	24	0.9	3.8	6.7	5.1	30	48	7	109140	Δ

Dimensions in mm

P	●
M	●
K	●
N	-
S	-
H	-

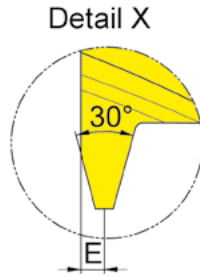
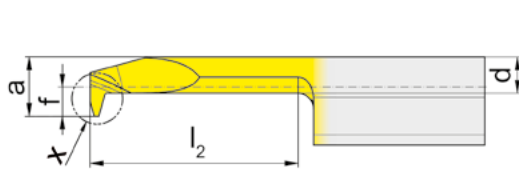
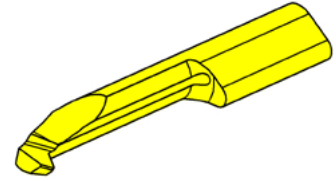
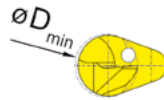
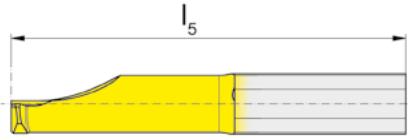
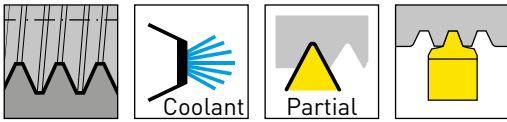

Coating grades

R = right hand version shown

▲ In stock

Δ 2 weeks

Part number	P	E	f	a	d	l_2	l_5	D_{min}	HIS	TH35
R109.0915.3.6	1.5	0.6	2.8	5.7	3.5	20	38	6	109140	▲
R109.1220.3.6	2	0.8	2.8	5.7	3.5	20	38	6	109140	▲
R109.1220.3.7	2	0.8	3.8	6.7	4.8	20	38	7	109140	▲
R109.1220.5.7	2	0.8	3.8	6.7	4.8	30	48	7	109140	▲
R109.1730.3.7	3	1.2	3.8	6.7	4.3	20	38	7	109140	▲

Metric trapezoidal thread

Dimensions in mm

P	●
M	●
K	●
N	-
S	-
H	-

B

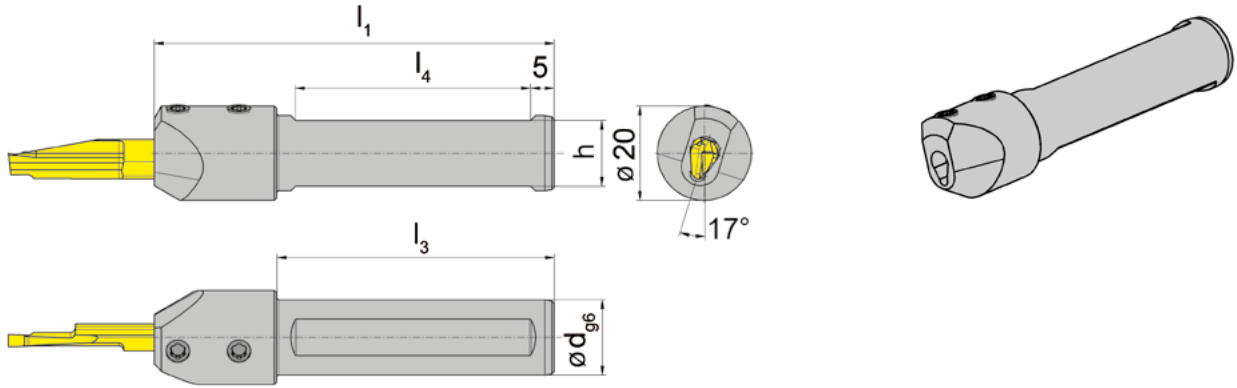
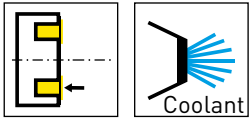

R = right hand version shown

L = left hand version

Part number	d	l ₁	l ₃	h	l ₄	HWS
RB109.0016.14.2	16	85	59	14	50	109240
LB109.0016.14.2	16	85	59	14	50	109240

Only compatible with inserts featuring an extended clamping shank. These inserts are identified on the following pages and marked with a note.

Dimensions in mm

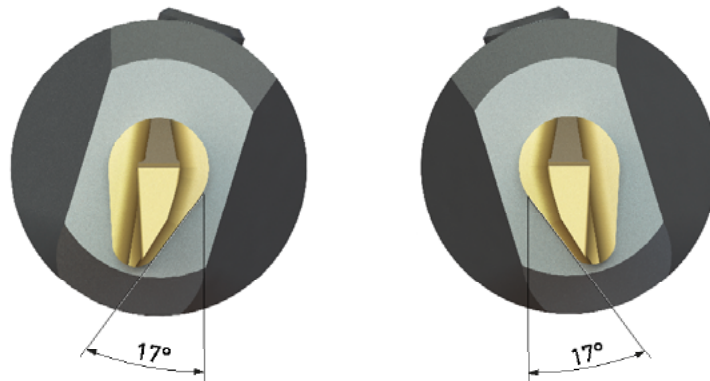

RA109 - RB109

LA109 - LB109

Spare Parts

Note: setup inserts are located at the end of the chapter

Toolholder	Clamping Screw	TORX PLUS® Wrench	Torque Value
R/LB109.0016.14.2	6.075T15P	T15PQ	5 Nm

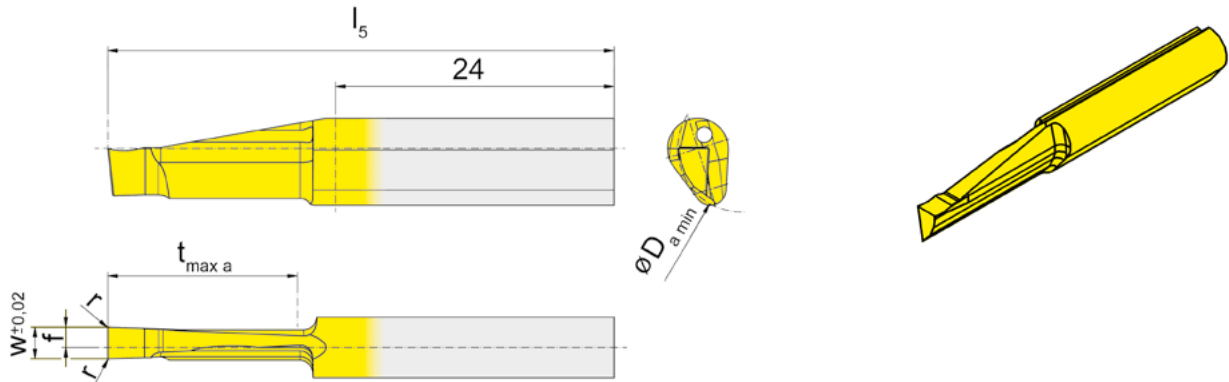
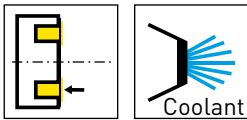

Coating grades

L = left hand version shown

R = right hand version

▲ In stock

Δ 2 weeks

Part number	w	r	f	l_5	$t_{\max a}$	$D_{a\ min}$	HIS		TI25
RA109.1520.3.2	2	0.1	1	48	20	15	109240	▲	●
RA109.1525.3.2	2.5	0.1	1.2	48	20	15	109240	▲	●
RA109.1530.3.2	3	0.1	1.5	48	20	15	109240	▲	●
LA109.1520.3.2	2	0.1	1	48	20	15	109240	Δ	●
LA109.1525.3.2	2.5	0.1	1.2	48	20	15	109240	Δ	●
LA109.1530.3.2	3	0.1	1.5	48	20	15	109240	▲	●

Only compatible with holders featuring an extended insert seat. These holders are identified on the previous pages and marked with a corresponding note.

Face grooving to the full width and full depth can only be performed for diameters between 15-40 mm. Do not exceed 40mm if grooving at full width and depth.

Dimensions in mm

P	●
M	●
K	-
N	●
S	-
H	-

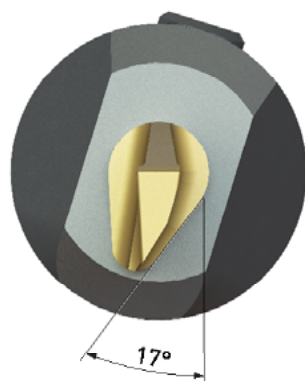

RA109 - RB109

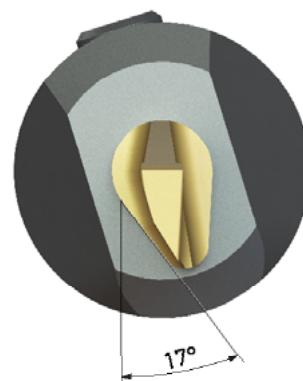

LA109 - LB109

B

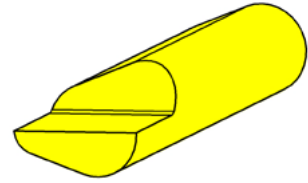
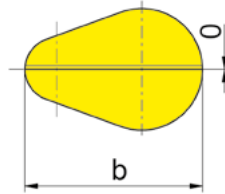
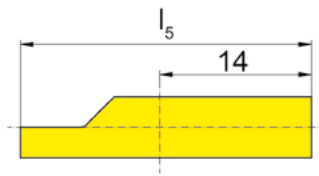
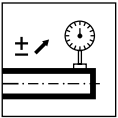

R = right hand version shown

L = left hand version

Part number	b	l_5	HIS
L109.LEHR.H.01 MG12	8.5	28	109140

Setup and calibration insert

Dimensions in mm

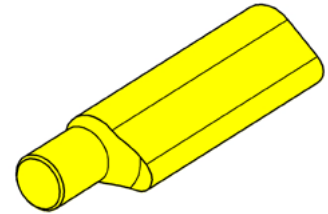
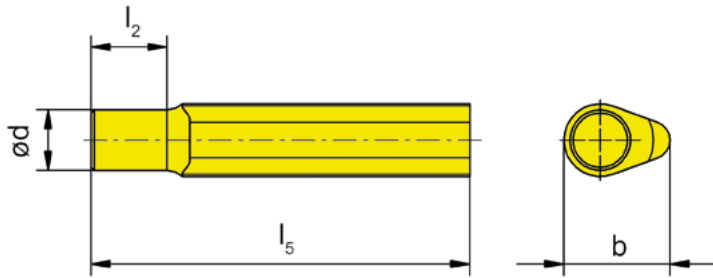
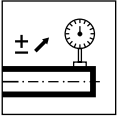

Part number	d	b	l ₂	l ₅	HIS
109.LEHR.D.01	4.5	8.5	5	25	109140

Setup and calibration insert

Dimensions in mm

NEED PRODUCT TRAINING?



Scan or click

SCAN THE QR CODE TO REGISTER FOR ON-SITE PRODUCT TRAINING

Hosted in the HORN Academy Training Center.

Learn to apply HORN product at the spindle.

Available to both distributors and end-users.

Hotel, transportation, and meals paid for by Horn USA.



C



SUPERMINI 110

C

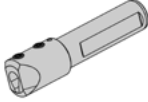
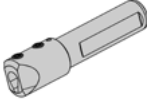
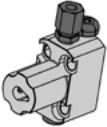
Bore Ø		Tool System											
mm	in	105	109	110	106	107	108	10P	111	11P	114	116	18P
≥ 0.2	≥ .0079	•											
≥ 0.5	≥ .0197	•											
≥ 0.7	≥ .0276	•											
≥ 1.0	≥ .0394	•											
≥ 1.5	≥ .0591	•											
≥ 2.0	≥ .0787	•											
≥ 3.0	≥ .1181	•											
≥ 4.0	≥ .1575	•											
≥ 5.0	≥ .1969	•											
≥ 6.0	≥ .2362	•	•	•	•								
≥ 6.8	≥ .2677		•	•	•								
≥ 7.0	≥ .2756		•			•							
≥ 7.8	≥ .3071			•		•	•						
≥ 8.0	≥ .3150			•		•	•						
≥ 9.0	≥ .3543			•		•	•	•					
≥ 10.0	≥ .3937			•				•	•	•			
≥ 10.5	≥ .4134									•			
≥ 11.0	≥ .4331								•	•			
≥ 11.5	≥ .4528									•			
≥ 13.8	≥ .5433										•		
≥ 14.0	≥ .5512										•	•	
≥ 16.0	≥ .6299									•		•	
≥ 16.5	≥ .6496										[•]		
≥ 18.0	≥ .7087												•
Depth of groove		2.5	2.5	4.0	0.8	2.0	1.0	3.0	2.3	3.5	4.0, [6.5]	4.3	8.0
		.0984	.0984	.1575	.0315	.0787	.0394	.1181	.0906	.1378	.1575, [.2559]	.1693	.3150
Width of groove		0.5-2.0	1.0-2.0	1.0-3.0	0.7-1.5	1.0-2.0	0.7-2.0	1.0-3.0	0.7-3.0	1.0-3.0	0.7-3.0	0.7-4.0	2.0-3.0
		.0197- .0787	.0394- .0787	.0394- .1181	.0276- .0591	.0394- .0787	.0276- .0787	.0394- .1181	.0276- .1181	.0394- .1181	.0276- .1181	.0276- .1575	.0787- .1181
Operations													
Grooving		•	•	•	•	•	•	•	•	•	•	•	•
Boring		•	•	•	•	•	•		•		•	•	
Threading		•	•			•	•		•		•	•	
Chamfering		•	•			•	•		•		•	•	
Face Grooving		•	•	•								•	
Boring and Profiling		•					•	•	•	•	•	•	

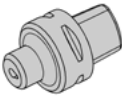
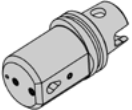
HOLDERS	Round Shank			
				
	Page 205 Holder BU110 Inch Shank		Page 207 Holder B110	
	Specialty			
				
	Page 208 Holder Graf N Adjustable		Page 210 Holder VDI	
				
Page 212 Holder B110C Polygonal		Page 211 Holder B110C Polygonal		

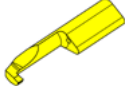
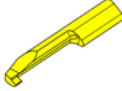
INSERTS	Boring		Grooving	
				
	Page 214-216 Boring, Profiling, Contouring		Page 222-223 Grooving	
				
	Page 217-221 Grooving Inch		Page 224-225 Grooving Full Radius, Inch	

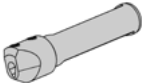
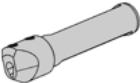
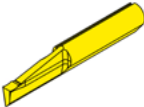
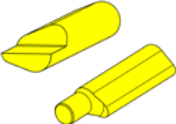
SPECIALTY	Face Grooving			Setup
				
	Page 226 Holder BU110 Angled seat, Inch		Page 227 Holder B110 Angled seat	
				
	Page 228-229 Face Grooving Angled neck			Page 230-231 Setup/Calibration

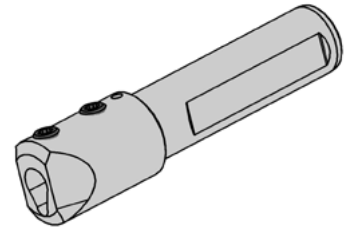
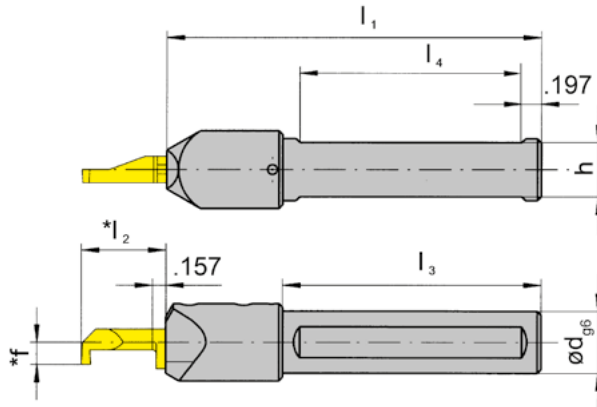
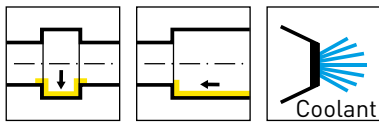

Picture = right hand insert shown

Part number	d	l ₁	l ₃	h	l ₄	HWS
BU110.0625.02	.625	3.996	2.815	.546	2.362	110260
BU110.0750.02	.750	3.996	2.815	.671	2.362	110260
BU110.1000.02	1.000	3.996	2.815	.921	2.362	110260

Dimensions in inch



Spare Parts

Note: setup inserts are located at the end of the chapter

Toolholder	Clamping Screw	TORX PLUS® Wrench	Torque Value
BU110...	6.075T15P	T15PQ	5 Nm

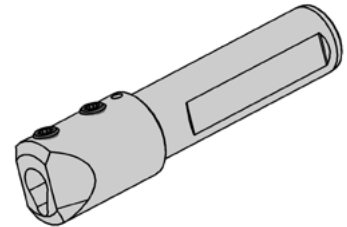
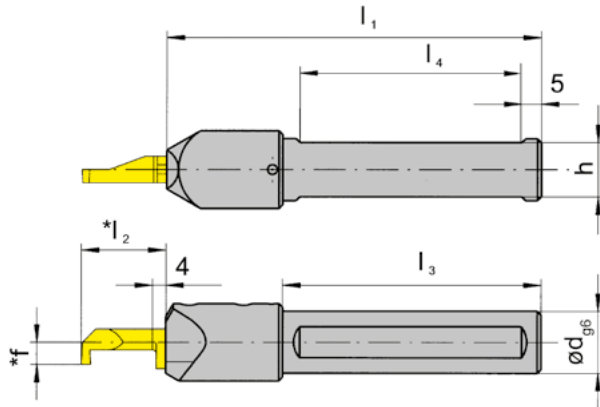
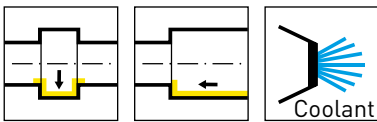

Picture = right hand insert shown

Part number	d	l ₁	l ₃	h	l ₄	HWS
B110.0016.02	16	100	70	14	55	110260
B110.0020.02	20	100	-	18	55	110260
B110.0022.02	22	100	-	20	55	110260
B110.0025.02	25	100	-	23	55	110260

For f and l₂, see inserts

Dimensions in mm

Spare Parts

Note: setup inserts are located at the end of the chapter

Toolholder	Clamping Screw	TORX PLUS® Wrench	Torque Value
B110...	6.075T15P	T15PQ	5 Nm

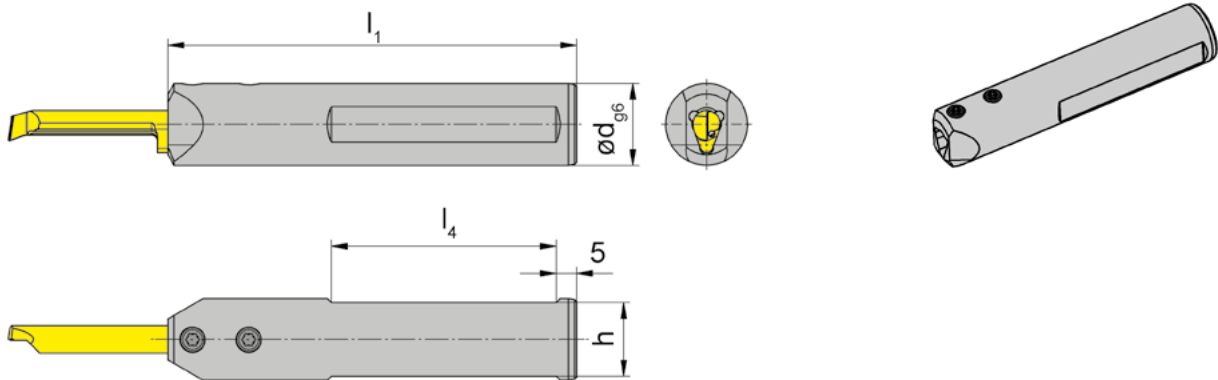
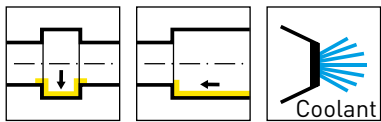

Picture = right hand insert shown

Part number	d	l ₁	h	l ₄	HWS
B110.0020.K.02	20	100	18	55	110260

Dimensions in mm

This holder features additional coolant holes

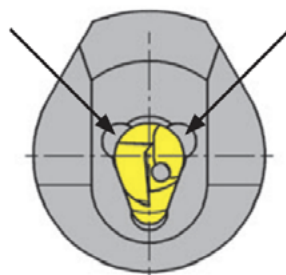

Spare Parts

Note: setup inserts are located at the end of the chapter

Toolholder	Clamping Screw	TORX PLUS® Wrench	Torque Value
B110.0020.K.02	6.075T15P	T15PQ	5 Nm

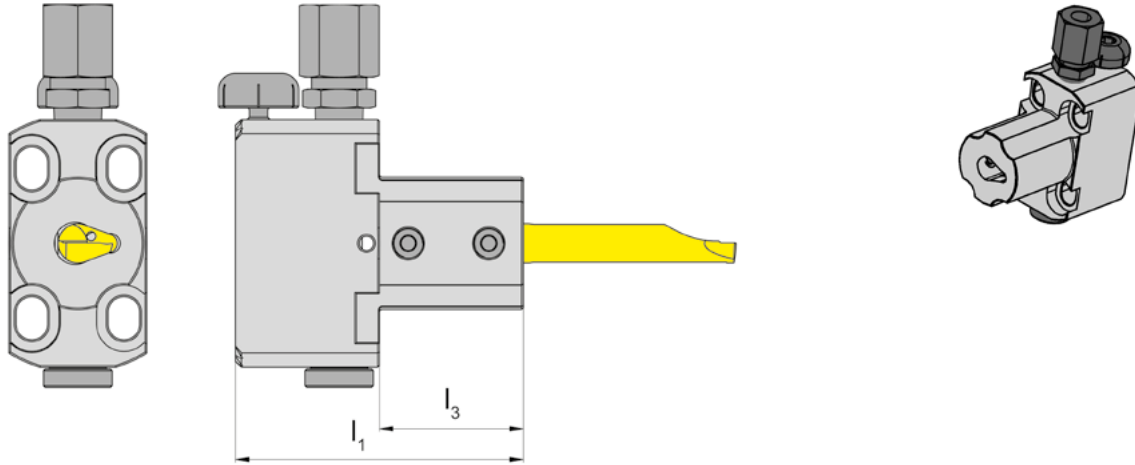
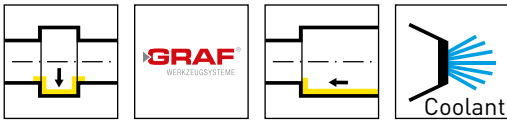

Picture = right hand cutting version

Part number	l_1	l_3	HWS
N.79.IK	50	25	110260

Coolant tube is not included - separate order required

Dimensions in mm

Spare Parts

Adjustable holder	Clamping Screw	Coolant supply	Torque Value
N.79.IK	6.075T15P	004.00.19	5 Nm

C

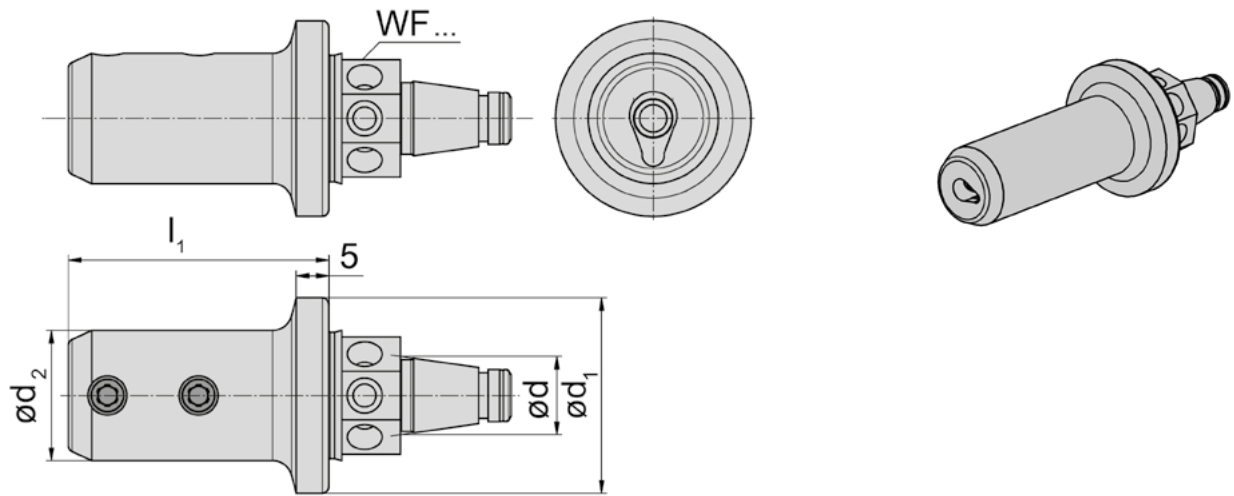

Part number	d ₁	l ₁	d	d ₂	HWS	HMS
WFB.2H0.110	30	40	12	20	110260	WFB
WFB.3H0.110	50	40	20	20	110260	WFB

For more W&F holder options, see our catalog - W&F Modular Technology for Swiss Type Machines

Dimensions in mm

Spare Parts

Note: setup inserts are located at the end of the chapter

Toolholder	Clamping Screw	TORX PLUS® Wrench	Torque Value
WFB...	6.075T15P	T15PQ	5 Nm

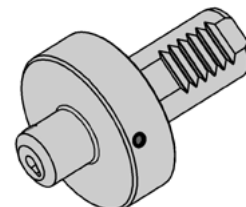
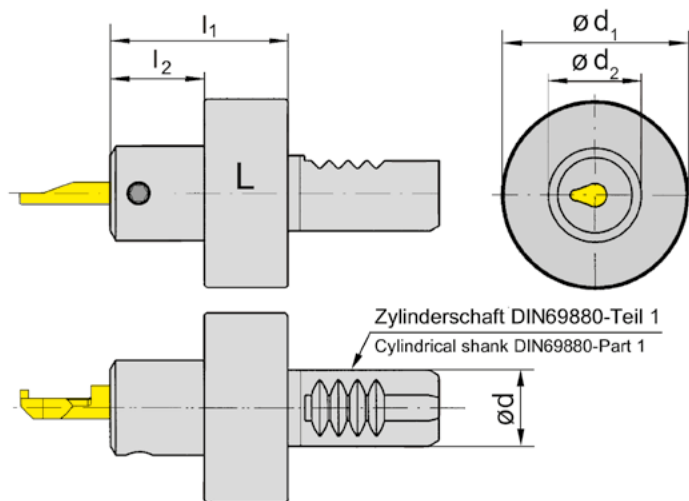
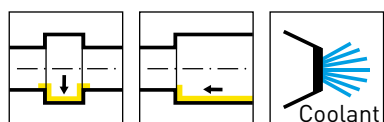

L = left hand version shown

R = right hand version

Part number	d	l ₁	l ₂	d ₂	d ₁	HWS
VDI16.L110.30.02	16	48	30	22	40	110260
VDI16.R110.30.02	16	48	30	22	40	110260
VDI20.R110.30.02	20	48	30	22	50	110260
VDI25.L110.30.02	25	48	30	22	58	110260
VDI25.R110.30.02	25	48	30	22	58	110260
VDI30.L110.30.02	30	48	30	22	68	110260
VDI30.R110.30.02	30	48	30	22	68	110260
VDI40.L110.30.02	40	48	30	22	83	110260
VDI40.R110.30.02	40	48	30	22	83	110260

Dimensions in mm

Spare Parts

Toolholder	Clamping Screw	TORX PLUS® Wrench	Torque Value
VDI16...	6.075T15P	T15PQ	5 Nm

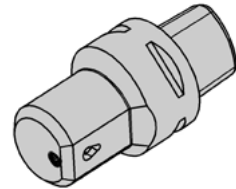
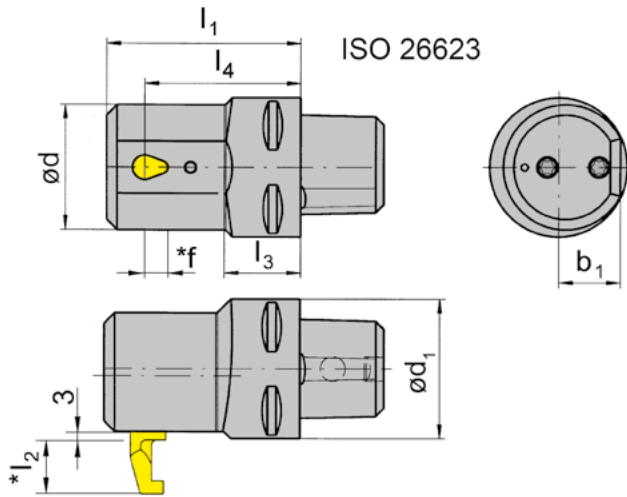
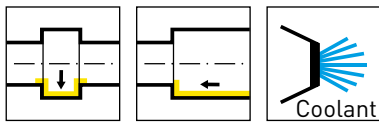

R = right hand version shown

Part number	d ₁	l ₃	d	l ₁	l ₄	b ₁	HWS
RB110.00C3.2.2.02	32	15	36	56	45	18	110260
RB110.00C4.2.2.02	40	22	36	56	45	18	110260

Polygonal shank according to ISO 26623

For INDEX Multi-spindle machines

For f and l₂, see inserts

Dimensions in mm

Spare Parts

Note: setup inserts are located at the end of the chapter

Toolholder	Clamping Screw	TORX PLUS® Wrench	Torque Value
RB110...	6.075T15P	T15PQ	5 Nm

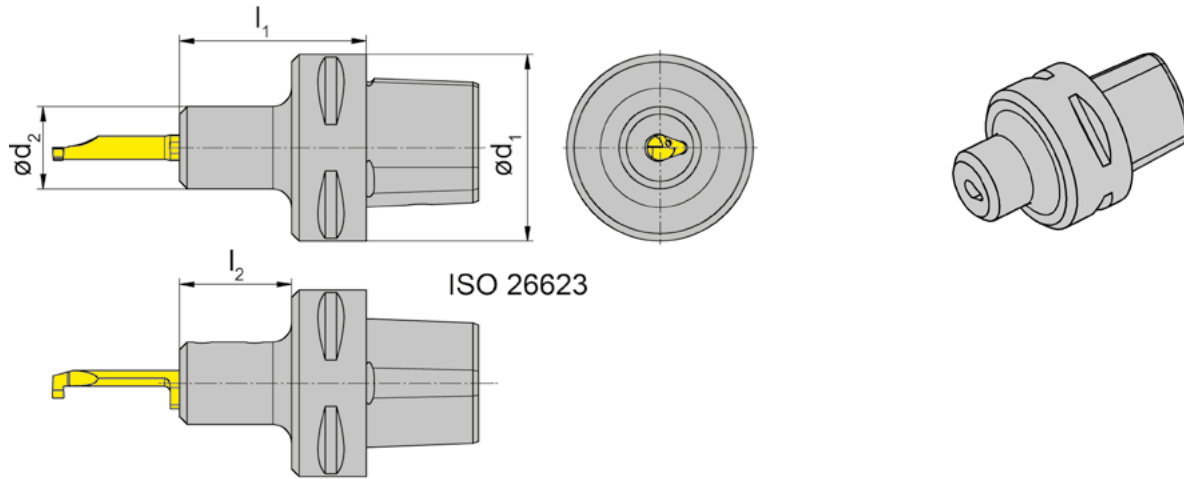
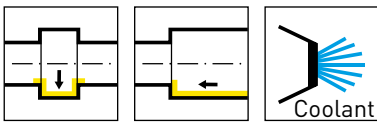

R = right hand version shown

L = left hand version

Part number	d ₁	d ₂	l ₁	l ₂	HWS
RB110.00C3.22.1.02	32	22	45	30	110260
RB110.00C4.22.1.02	40	22	50	30	110260
RB110.00C5.22.1.02	50	22	50	30	110260
RB110.00C6.22.1.02	63	22	52	30	110260
LB110.00C3.22.1.02	32	22	45	30	110260
LB110.00C4.22.1.02	40	22	50	30	110260
LB110.00C5.22.1.02	50	22	50	30	110260
LB110.00C6.22.1.02	63	22	52	30	110260

Polygonal shank according to ISO 26623

Dimensions in mm

Spare Parts

Note: setup inserts are located at the end of the chapter

Toolholder	Clamping Screw	TORX PLUS® Wrench	Torque Value
R/LB110...	6.075T15P	T15PQ	5 Nm



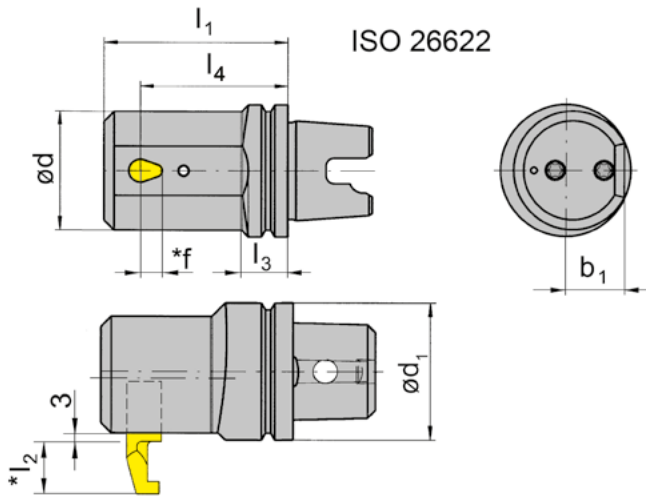
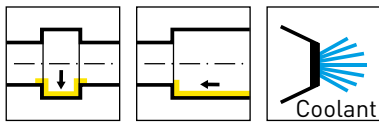

ISO 26622

R = right hand version shown

Part number	d ₁	l ₃	d	l ₁	l ₄	b ₁	Machine type	HWS
RB110.TS40.2.2.02	40	14	36	56	45	18	INDEX MS32	110260

For INDEX Multi-spindle machines

For f and l₂, see inserts

Dimensions in mm

Spare Parts

Note: setup inserts are located at the end of the chapter

Toolholder	Clamping Screw	TORX PLUS® Wrench	Torque Value
RB110.TS40.2.2.02	6.075T15P	T15PQ	5 Nm

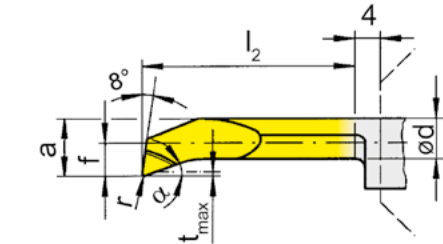
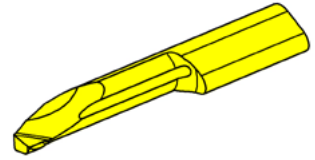
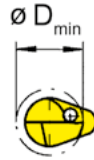
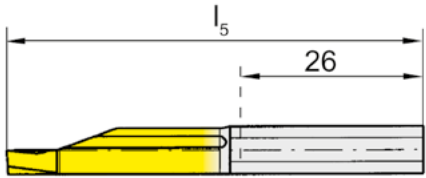
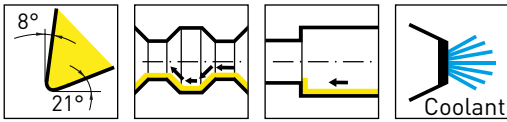

R = right hand version shown

L = left hand version

▲ In stock

Δ 2 weeks

Coating grades

Part number	r	f	a	d	l_2	l_5	t_{max}	D_{min}	α	HIS	EG35	TH35	TI25
R110.1829.7.6	0.2	2.9	5.7	4.8	40	70	0.5	6	21°	110260	▲	▲	▲
R110.1829.9.6	0.2	2.9	5.7	4.8	50	80	0.5	6	21°	110260	▲	▲	▲
R110.1829.9.8	0.2	4	7.4	6	50	80	0.5	8	21°	110260	▲	▲	▲
L110.1829.7.6	0.2	2.9	5.7	4.8	40	70	0.5	6	21°	110260	▲	▲	▲
L110.1829.9.6	0.2	2.9	5.7	4.8	50	80	0.5	6	21°	110260	▲	▲	▲
L110.1829.9.8	0.2	4	7.4	6	50	80	0.5	8	21°	110260	▲	▲	▲

Dimensions in mm

P	●	●	●
M	●	●	●
K	●	●	-
N	○	-	●
S	-	-	-
H	-	-	-

C

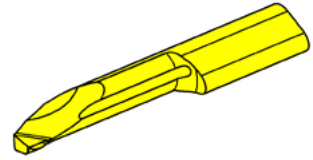
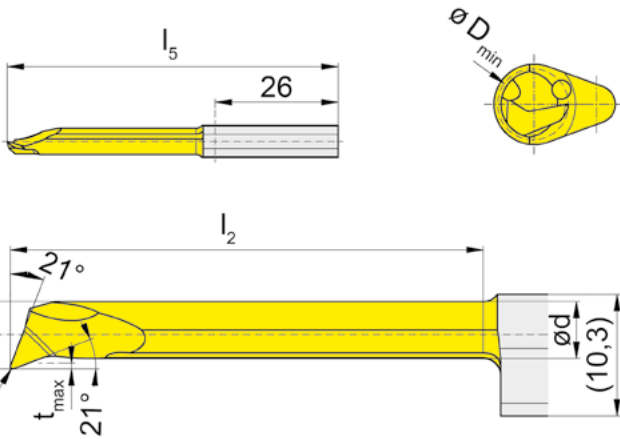
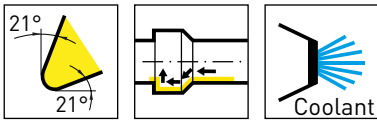

Coating grades

R = right hand version shown

L = left hand version

▲ In stock

Δ 2 weeks

Part number	r	f	a	d	l ₂	l ₅	t _{max}	D _{min}	HIS	EG35
R110.2129.7.6	0.2	2.9	5.7	4.8	40	70	0.5	6	110260	Δ
R110.2129.9.6	0.2	2.9	5.7	4.8	50	80	0.5	6	110260	Δ
R110.2140.7.8	0.2	4	7.4	6	40	70	0.5	8	110260	Δ
R110.2140.9.8	0.2	4	7.4	6	50	80	0.5	8	110260	Δ
L110.2129.7.6	0.2	2.9	5.7	4.8	40	70	0.5	6	110260	Δ
L110.2129.9.6	0.2	2.9	5.7	4.8	50	80	0.5	6	110260	Δ
L110.2140.7.8	0.2	4	7.4	6	40	70	0.5	8	110260	Δ
L110.2140.9.8	0.2	4	7.4	6	50	80	0.5	8	110260	Δ

Dimensions in mm

P	●
M	●
K	●
N	○
S	-
H	-

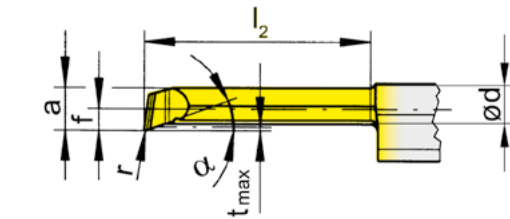
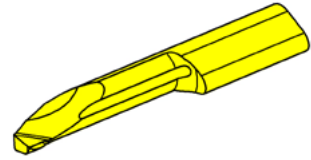
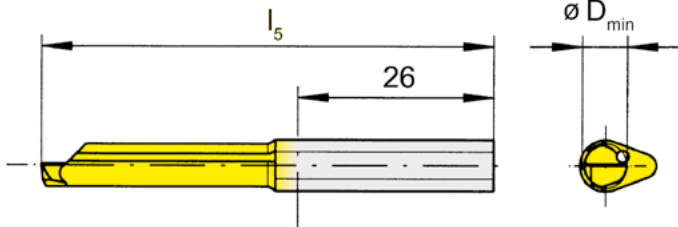
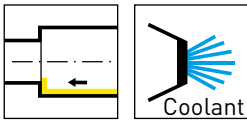

Coating grades

R = right hand version shown

▲ In stock

Δ 2 weeks

Part number	r	f	a	d	l_2	l_5	t_{max}	D_{min}	α	HIS	EG35	TI25
R110.1829.9.H6	0.2	2.9	5.7	4.8	50	80	0.5	6	20°	110260	▲	▲
R110.1829.9.H8	0.2	4	7.4	6	50	80	0.5	8	20°	110260	▲	▲

These inserts feature a „chip staircase“ geometry to break chips during boring operations

Dimensions in mm

P	●	●
M	●	●
K	●	-
N	○	●
S	-	-
H	-	-



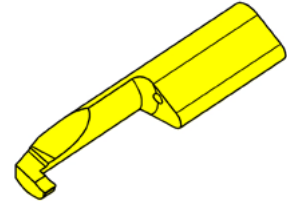
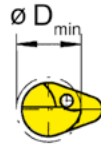
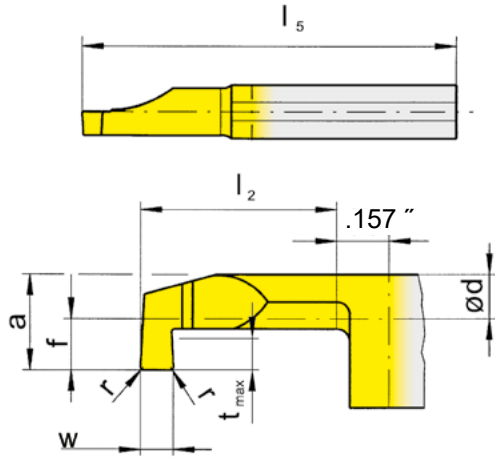
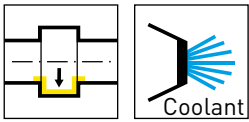

Coating grades

R = right hand version shown

L = left hand version

▲ In stock

△ 2 weeks

Part number	w	r	f	a	d	l ₂	l ₅	t _{max}	D _{min}	HIS	IG35	TI25
RU110.1208.3.8	.125	.008	.157	.291	.165	.787	1.969	.110	.315	110260	▲	▲
RU110.1208.7.8	.125	.008	.157	.291	.165	1.575	2.756	.110	.315	110260	▲	▲
RU110.2508.3.8	.250	.008	.157	.291	.165	.787	1.969	.110	.315	110260	▲	▲
RU110.2508.7.8	.250	.008	.157	.291	.165	1.575	2.756	.110	.315	110260	▲	▲
RU110.4608.3.8	.046	.008	.157	.291	.165	.787	1.969	.110	.315	110260	▲	▲
RU110.4608.7.8	.046	.008	.157	.291	.165	1.575	2.756	.110	.315	110260	▲	▲
RU110.6208.3.8	.062	.008	.157	.291	.165	.787	1.969	.110	.315	110260	▲	▲
RU110.6208.7.8	.062	.008	.157	.291	.165	1.575	2.756	.110	.315	110260	▲	▲
RU110.7808.3.8	.078	.008	.157	.291	.165	.787	1.969	.110	.315	110260	▲	▲
RU110.7808.7.8	.078	.008	.157	.291	.165	1.575	2.756	.110	.315	110260	▲	▲
RU110.9408.3.8	.094	.008	.157	.291	.165	.787	1.969	.110	.315	110260	▲	▲
RU110.9408.7.8	.094	.008	.157	.291	.165	1.575	2.756	.110	.315	110260	▲	▲
LU110.1208.3.8	.125	.008	.157	.291	.165	.787	1.969	.110	.315	110260	△	△
LU110.6208.7.8	.062	.008	.157	.291	.165	1.575	2.756	.110	.315	110260	△	△

Dimensions in inch



P	●	●
M	●	●
K	●	-
N	○	●
S	○	-
H	-	-

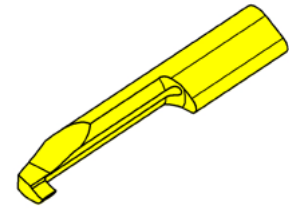
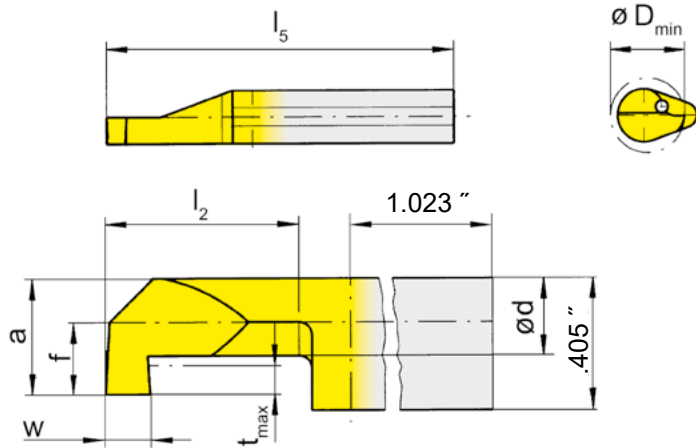
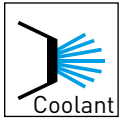
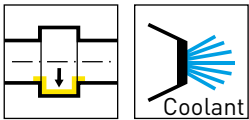

Coating grades

R = right hand version shown

L = left hand version shown

▲ In stock

△ 2 weeks

Part number	w	f	a	d	l_2	l_5	t_{max}	D_{min}	HIS	IG35	TI25
RU110.0046.3.8	.046	.157	.291	.165	.787	1.969	.110	.315	110260	▲	▲
RU110.0046.7.8	.046	.157	.291	.165	1.575	2.756	.110	.315	110260	▲	▲
RU110.0062.3.8	.062	.157	.291	.165	.787	1.969	.110	.315	110260	▲	▲
RU110.0062.7.8	.062	.157	.291	.165	1.575	2.756	.110	.315	110260	▲	▲
RU110.0078.3.8	.078	.157	.291	.165	.787	1.969	.110	.315	110260	▲	▲
RU110.0078.7.8	.078	.157	.291	.165	1.575	2.756	.110	.315	110260	▲	▲
RU110.0094.3.8	.094	.157	.291	.165	.787	1.969	.110	.315	110260	▲	▲
RU110.0094.7.8	.094	.157	.291	.165	1.575	2.756	.110	.315	110260	▲	▲
RU110.0125.3.8	.125	.157	.283	.165	.787	1.969	.110	.315	110260	▲	▲
RU110.0125.7.8	.125	.157	.291	.165	1.575	2.756	.110	.315	110260	▲	▲
RU110.0250.3.8	.250	.157	.283	.165	.787	1.969	.110	.315	110260	▲	▲
RU110.0250.7.8	.250	.157	.283	.165	1.575	2.756	.110	.315	110260	▲	▲
LU110.0062.3.8	.062	.157	.291	.165	.787	1.969	.110	.315	110260	△	△
LU110.0094.3.8	.094	.157	.291	.165	.787	1.969	.110	.315	110260	△	△

Dimensions in inch



P	●	●
M	●	●
K	●	-
N	○	●
S	○	-
H	-	-

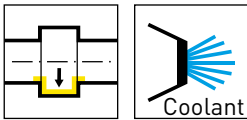

C

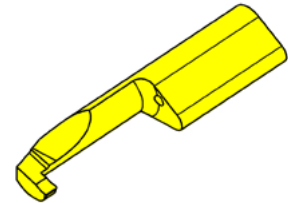
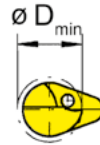
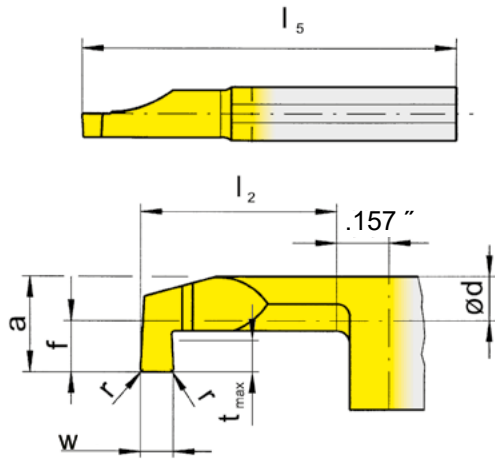

Coating grades

R = right hand version shown

L = left hand version

▲ In stock

△ 2 weeks

Part number	w	r	f	a	d	l_2	l_5	t_{max}	D_{min}	HIS	IG35	TI25
RU110.1208.3.0	.125	.008	.236	.370	.197	.787	1.969	.157	.394	110260	▲	▲
RU110.1208.7.0	.125	.008	.236	.370	.197	1.575	2.756	.157	.394	110260	▲	▲
RU110.2508.3.0	.250	.008	.236	.370	.197	.787	1.969	.157	.394	110260	▲	▲
RU110.2508.7.0	.250	.008	.236	.370	.197	1.575	2.756	.157	.394	110260	▲	▲
RU110.4608.3.0	.046	.008	.236	.370	.197	.787	1.969	.157	.394	110260	▲	▲
RU110.4608.7.0	.046	.008	.236	.370	.197	1.575	2.756	.157	.394	110260	▲	▲
RU110.6208.3.0	.062	.008	.236	.370	.197	.787	1.969	.157	.394	110260	▲	▲
RU110.6208.7.0	.062	.008	.236	.370	.197	1.575	2.756	.157	.394	110260	▲	▲
RU110.7808.3.0	.078	.008	.236	.370	.197	.787	1.969	.157	.394	110260	▲	▲
RU110.7808.7.0	.078	.008	.236	.370	.197	1.575	2.756	.157	.394	110260	▲	▲
RU110.9408.3.0	.094	.008	.236	.370	.197	.787	1.969	.157	.394	110260	▲	▲
RU110.9408.7.0	.094	.008	.236	.370	.197	1.575	2.756	.157	.394	110260	▲	▲
LU110.1208.3.0	.125	.008	.236	.370	.197	.787	1.969	.157	.394	110260	△	△
LU110.2508.3.0	.250	.008	.236	.370	.197	.787	1.969	.157	.394	110260	△	△
LU110.6208.3.0	.062	.008	.236	.370	.197	.787	1.969	.157	.394	110260	△	△

Dimensions in inch



P	●	●
M	●	●
K	●	-
N	o	●
S	o	-
H	-	-

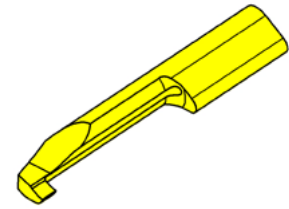
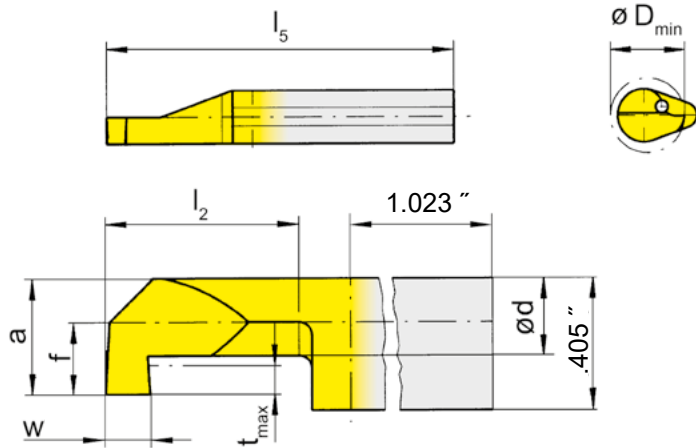
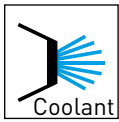
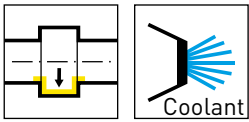

Coating grades

R = right hand version shown

L = left hand version

▲ In stock

△ 2 weeks

Part number	w	f	a	d	l_2	l_5	t_{max}	D_{min}	HIS	IG35	TI25
RU110.0046.1.0	.046	.236	.370	.197	.394	1.575	.157	.394	110260	▲	▲
RU110.0046.3.0	.046	.236	.370	.197	.787	1.969	.157	.394	110260	▲	▲
RU110.0062.1.0	.062	.236	.370	.197	.394	1.575	.157	.394	110260	▲	▲
RU110.0062.3.0	.062	.236	.370	.197	.787	1.969	.157	.394	110260	▲	▲
RU110.0078.1.0	.078	.236	.370	.197	.394	1.575	.157	.394	110260	▲	▲
RU110.0078.3.0	.078	.236	.370	.197	.787	1.969	.157	.394	110260	▲	▲
RU110.0094.1.0	.094	.236	.370	.197	.394	1.575	.157	.394	110260	▲	▲
RU110.0094.3.0	.094	.236	.370	.197	.787	1.969	.157	.394	110260	▲	▲
RU110.0125.1.0	.125	.236	.370	.197	.394	1.575	.157	.394	110260	▲	▲
RU110.0125.3.0	.125	.236	.370	.197	.787	1.969	.157	.394	110260	▲	▲
RU110.0250.3.0	.250	.236	.370	.197	.787	1.969	.157	.394	110260	▲	▲
LU110.0062.1.0	.062	.236	.370	.197	.394	1.575	.157	.394	110260	△	△
LU110.0078.1.0	.078	.236	.370	.197	.394	1.575	.157	.394	110260	△	△
LU110.0094.3.0	.094	.236	.370	.197	.787	1.969	.157	.394	110260	△	△

Dimensions in inch



P	●	●
M	●	●
K	●	-
N	○	●
S	○	-
H	-	-

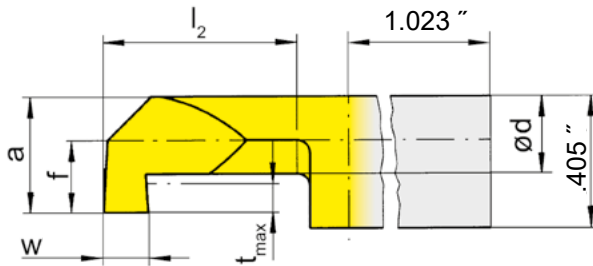
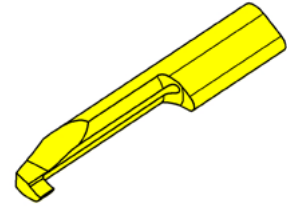
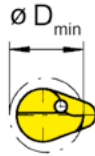
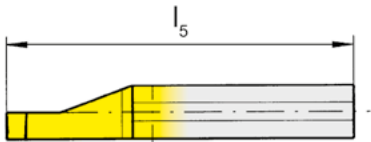
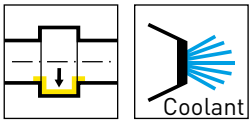

Coating grades

R = right hand version shown

L = left hand version

▲ In stock

△ 2 weeks

Part number	w	f	a	d	l_2	l_5	t_{max}	D_{min}	HIS	IG35	TI25
RU110.0046.5.0	.046	.236	.370	.197	1.181	2.362	.157	.394	110260	▲	▲
RU110.0046.7.0	.046	.236	.370	.197	1.575	2.756	.157	.394	110260	▲	▲
RU110.0062.5.0	.062	.236	.370	.197	1.181	2.362	.157	.394	110260	▲	▲
RU110.0062.7.0	.062	.236	.370	.197	1.575	2.756	.157	.394	110260	▲	▲
RU110.0078.5.0	.078	.236	.370	.197	1.181	2.362	.157	.394	110260	▲	▲
RU110.0078.7.0	.078	.236	.370	.197	1.575	2.756	.157	.394	110260	▲	▲
RU110.0094.5.0	.094	.236	.370	.197	1.181	2.362	.157	.394	110260	▲	▲
RU110.0094.7.0	.094	.236	.370	.197	1.575	2.756	.157	.394	110260	▲	▲
RU110.0125.5.0	.125	.236	.370	.197	1.181	2.362	.157	.394	110260	▲	▲
RU110.0125.7.0	.125	.236	.370	.197	1.575	2.756	.157	.394	110260	▲	▲
RU110.0250.5.0	.250	.236	.370	.197	1.181	2.362	.157	.394	110260	▲	▲
RU110.0250.7.0	.250	.236	.370	.197	1.575	2.756	.157	.394	110260	▲	▲
LU110.0094.5.0	.094	.236	.370	.197	1.181	2.362	.157	.394	110260	△	△

Dimensions in inch



P	●	●
M	●	●
K	●	-
N	o	●
S	o	-
H	-	-

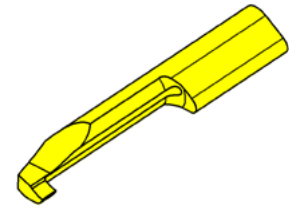
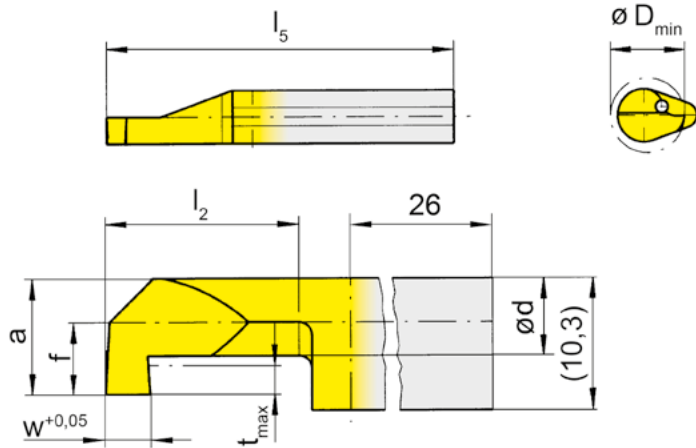
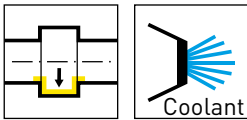

Coating grades

R = right hand version shown

L = left hand version

▲ In stock

Δ 2 weeks

Part number	w	f	a	d	l ₂	l ₅	t _{max}	D _{min}	HIS	EG35	IG35	TN35
R110.0100.5.8	1	4	7.4	4.2	30	60	2.8	8	110260	▲		▲
R110.0200.5.8	2	4	7.4	4.2	30	60	2.8	8	110260	▲	▲	▲
R110.0250.5.8	2.5	4	7.4	4.2	30	60	2.8	8	110260	▲		▲
R110.0100.7.8	1	4	7.4	4.2	40	70	2.8	8	110260	▲		▲
R110.0200.7.8	2	4	7.4	4.2	40	70	2.8	8	110260	▲		▲
R110.0250.7.8	2.5	4	7.4	4.2	40	70	2.8	8	110260	▲		▲
R110.0100.5.0	1	6	9.4	5	30	60	4	10	110260	▲		▲
R110.0200.5.0	2	6	9.4	5	30	60	4	10	110260	▲		▲
R110.0300.5.0	3	6	9.4	5	30	60	4	10	110260	▲		▲
R110.0100.9.0	1	6	9.4	5	50	80	4	10	110260	Δ		▲
R110.0200.9.0	2	6	9.4	5	50	80	4	10	110260	▲		▲
R110.0300.9.0	3	6	9.4	5	50	80	4	10	110260	▲		▲
L110.0100.5.8	1	4	7.4	4.2	30	60	2.8	8	110260	▲		▲
L110.0200.5.8	2	4	7.4	4.2	30	60	2.8	8	110260	▲		▲
L110.0250.5.8	2.5	4	7.4	4.2	30	60	2.8	8	110260	▲		▲
L110.0100.7.8	1	4	7.4	4.2	40	70	2.8	8	110260	Δ		▲
L110.0200.7.8	2	4	7.4	4.2	40	70	2.8	8	110260	▲		▲
L110.0250.7.8	2.5	4	7.4	4.2	40	70	2.8	8	110260	Δ		▲
L110.0100.5.0	1	6	9.4	5	30	60	4	10	110260	▲		▲
L110.0200.5.0	2	6	9.4	5	30	60	4	10	110260	▲		▲
L110.0300.5.0	3	6	9.4	5	30	60	4	10	110260	▲		▲
L110.0100.9.0	1	6	9.4	5	50	80	4	10	110260	Δ		▲
L110.0200.9.0	2	6	9.4	5	50	80	4	10	110260	Δ		▲
L110.0300.9.0	3	6	9.4	5	50	80	4	10	110260	Δ		Δ

Dimensions in mm

P	●	●	●
M	●	●	-
K	●	●	●
N	○	○	○
S	-	○	-
H	-	-	-

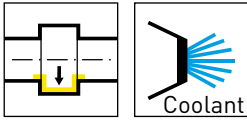

C

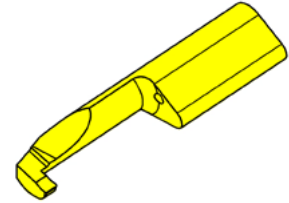
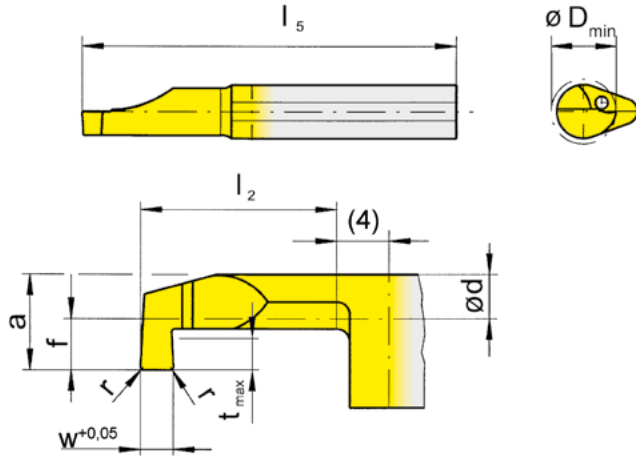

Coating grades

R = right hand version shown

▲ In stock

Δ 2 weeks

Part number	w	r	f	a	d	l_2	l_5	t_{max}	D_{min}	HIS		EG35	TN35
R110.0200.02.3.8	2	0.2	4	7.4	4.2	20	50	2.8	8	110260		▲	▲
												P	● ●
												M	● -
												K	● ●
												N	○ ○
												S	- -
												H	- -

Dimensions in mm

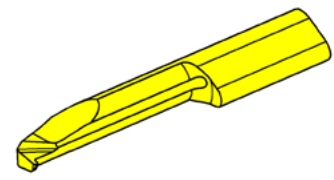
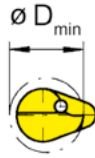
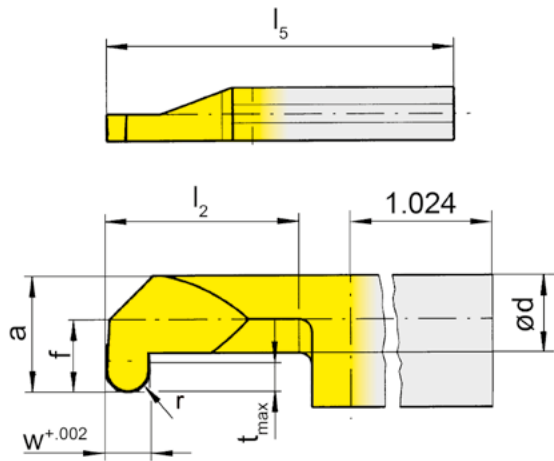
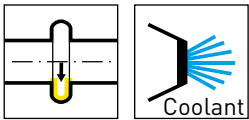

Coating grades

R = right hand version shown

L = left hand version

▲ In stock

Δ 2 weeks

Part number	w	r	f	a	d	l_2	l_5	t_{max}	D_{min}	HIS	IG35	TI25
RU110.3162.1.8	.062	.031	.157	.291	.165	.394	1.575	.110	.315	110260	▲	▲
RU110.3162.3.8	.062	.031	.157	.291	.165	.787	1.969	.110	.315	110260	▲	▲
RU110.3162.5.8	.062	.031	.157	.291	.165	1.181	2.362	.110	.315	110260	▲	▲
RU110.3162.7.8	.062	.031	.157	.291	.165	1.575	2.756	.110	.315	110260	▲	▲
RU110.4794.1.8	.094	.047	.157	.291	.165	.787	1.575	.110	.315	110260	▲	▲
RU110.4794.3.8	.094	.047	.157	.291	.165	.787	1.969	.110	.315	110260	▲	▲
RU110.4794.5.8	.094	.047	.157	.291	.165	1.181	2.362	.110	.315	110260	▲	▲
RU110.4794.7.8	.094	.047	.157	.291	.165	1.575	2.756	.110	.315	110260	▲	▲
RU110.6212.1.8	.125	.047	.157	.291	.165	.394	1.575	.110	.315	110260	▲	▲
RU110.6212.3.8	.125	.063	.157	.291	.165	.787	1.969	.110	.315	110260	▲	▲
RU110.6212.5.8	.125	.063	.157	.291	.165	1.181	2.362	.110	.315	110260	▲	▲
RU110.6212.7.8	.125	.063	.157	.291	.165	1.575	2.756	.110	.315	110260	▲	▲
LU110.3162.1.8	.062	.031	.157	.291	.165	.394	1.575	.110	.315	110260	Δ	Δ
LU110.3162.3.8	.062	.031	.157	.291	.165	.787	1.969	.110	.315	110260	Δ	Δ
LU110.4794.1.8	.094	.047	.157	.291	.165	.787	1.575	.110	.315	110260	Δ	Δ
LU110.4794.3.8	.094	.047	.157	.291	.165	.787	1.969	.110	.315	110260	Δ	Δ
LU110.6212.1.8	.125	.047	.157	.291	.165	.394	1.575	.110	.315	110260	Δ	Δ

Dimensions in inch



P	●	●
M	●	●
K	●	-
N	○	●
S	○	-
H	-	-

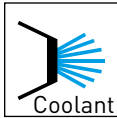
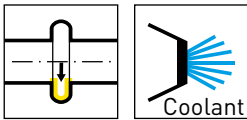

C

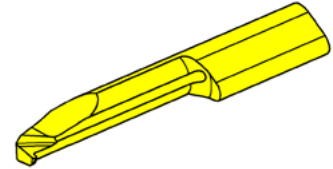
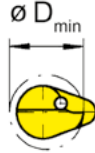
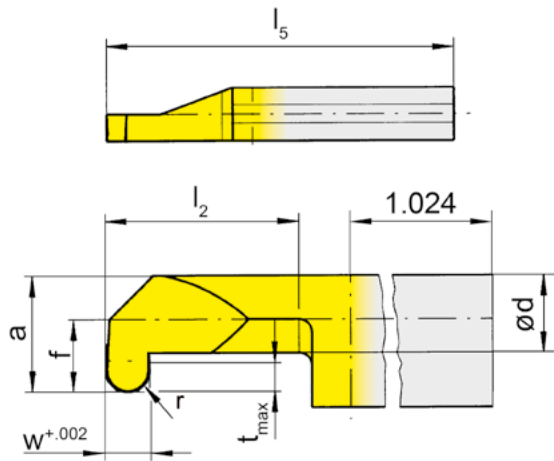

Coating grades

R = right hand version shown

L = left hand version

▲ In stock

△ 2 weeks

Part number	w	r	f	a	d	l_2	l_5	t_{max}	D_{min}	HIS	IG35	TI25
RU110.3162.1.0	.062	.031	.236	.370	.197	.394	1.575	.157	.394	110260	▲	▲
RU110.3162.3.0	.062	.031	.236	.370	.197	.787	1.969	.157	.394	110260	▲	▲
RU110.3162.5.0	.062	.031	.236	.370	.197	1.181	2.362	.157	.394	110260	▲	▲
RU110.3162.7.0	.062	.031	.236	.370	.197	1.575	2.756	.157	.394	110260	▲	▲
RU110.4794.1.0	.094	.047	.236	.370	.197	.394	1.575	.157	.394	110260	▲	▲
RU110.4794.3.0	.094	.047	.236	.370	.197	.787	1.969	.157	.394	110260	▲	▲
RU110.4794.5.0	.094	.047	.236	.370	.197	1.181	2.362	.157	.394	110260	▲	▲
RU110.4794.7.0	.094	.047	.236	.370	.197	1.575	2.756	.157	.394	110260	▲	▲
RU110.6212.1.0	.125	.063	.236	.370	.197	.394	1.575	.157	.394	110260	▲	▲
RU110.6212.3.0	.125	.063	.236	.370	.197	.787	1.969	.157	.394	110260	▲	▲
RU110.6212.5.0	.125	.063	.236	.370	.197	1.181	2.362	.157	.394	110260	▲	▲
RU110.6212.7.0	.125	.063	.236	.370	.197	1.575	2.756	.157	.394	110260	▲	▲
LU110.3162.1.0	.062	.031	.236	.370	.197	.394	1.575	.157	.394	110260	△	△
LU110.3162.5.0	.062	.031	.236	.370	.197	1.181	2.362	.157	.394	110260	△	△
LU110.4794.3.0	.094	.047	.236	.370	.197	.787	1.969	.157	.394	110260	△	△
LU110.4794.5.0	.094	.047	.236	.370	.197	1.181	2.362	.157	.394	110260	△	△
LU110.4794.7.0	.094	.047	.236	.370	.197	1.575	2.756	.157	.394	110260	△	△

Dimensions in inch



P	●	●
M	●	●
K	●	-
N	○	●
S	○	-
H	-	-

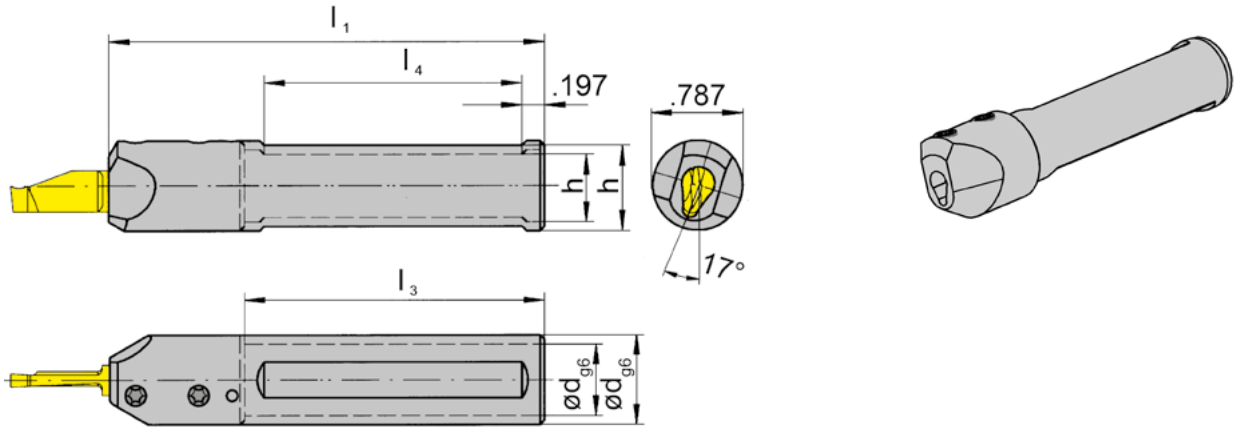
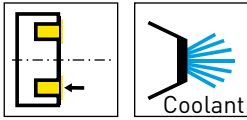

R = right hand version shown

L = left hand version

Part number	d	l ₁	l ₃	h	l ₄	HWS
RBU110.0625.16.2	.625	3.996	2.756	.546	2.362	110260
RBU110.0750.16.2	.750	3.996	2.756	.671	2.362	110260
LBU110.0625.16.2	.625	3.996	2.756	.546	2.362	110260
LBU110.0750.16.2	.750	3.996	2.756	.671	2.362	110260

These holders are rotated/cranked at 17° and are only compatible with the RA/LA inserts on the following pages. The inserts are marked with a note.

Dimensions in inch

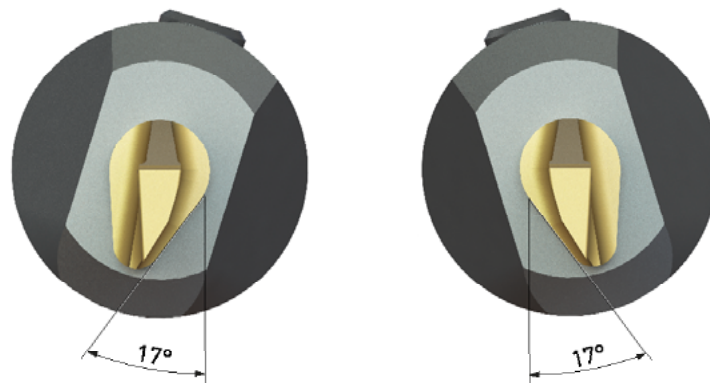

RA110 - RBU110

LA110 - LBU110

Spare Parts

Note: setup inserts are located at the end of the chapter

Toolholder	Clamping Screw	TORX PLUS® Wrench	Torque Value
R/LBU110...	6.075T15P	T15PQ	5 Nm



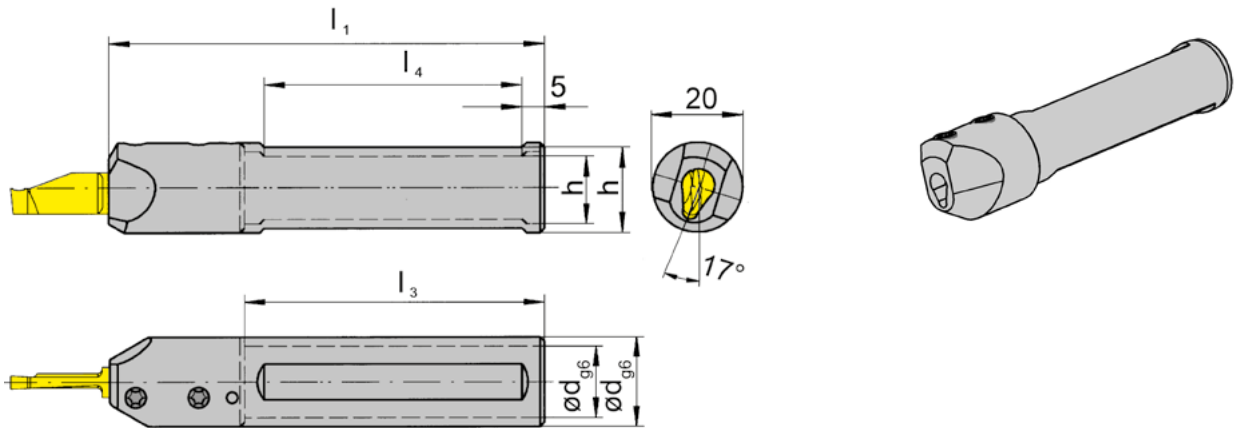
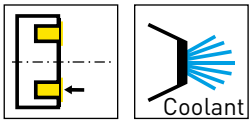

R = right hand version shown

L = left hand version

Part number	d	l ₁	l ₃	h	l ₄	HWS
RB110.0016.16.2	16	100	70	14	55	110260
RB110.0020.16.2	20	100	-	18	55	110260
LB110.0016.16.2	16	100	70	14	55	110260
LB110.0020.16.2	20	100	-	18	55	110260

These holders are rotated/cranked at 17° and are only compatible with the RA/LA inserts on the following pages. The inserts are marked with a note.

Dimensions in mm

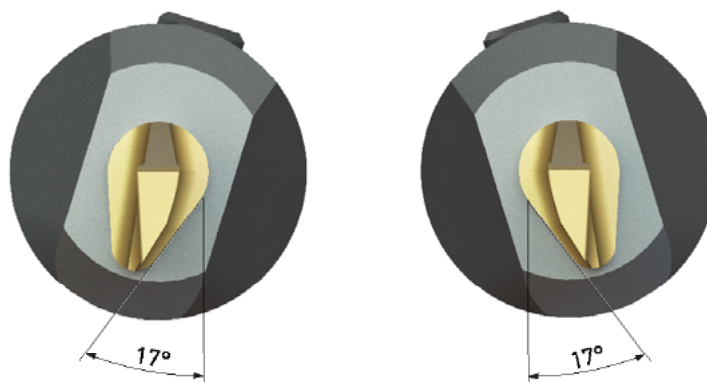

RA110 - RB110

LA110 - LB110

Spare Parts

Note: setup inserts are located at the end of the chapter

Toolholder	Clamping Screw	TORX PLUS® Wrench	Torque Value
R/LB110...	6.075T15P	T15PQ	5 Nm

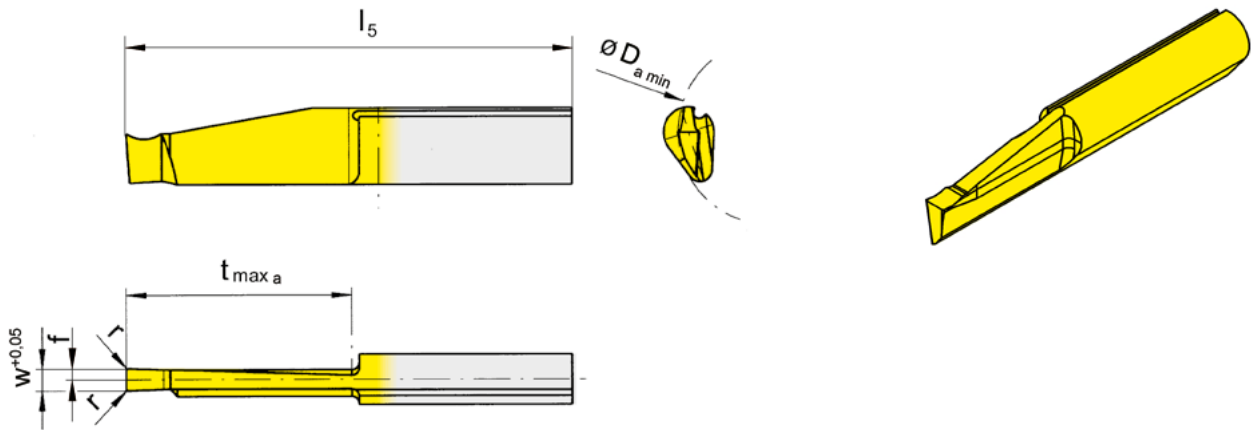
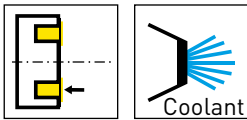

L = left hand version shown

R = right hand version

▲ In stock

Δ 2 weeks

Coating grades

Part number	w	r	f	l ₅	t _{max a}	D _{a min}	HIS	Coating grades			
								EG35	TH35	TI25	TN35
RA110.2030.3.0	3	0.2	1.5	50	20	20	110260	▲	▲	▲	▲
RA110.2030.5.0	3	0.2	1.5	60	30	20	110260	▲	▲	▲	▲
RA110.5030.3.0	3	0.2	1.5	50	20	50	110260	▲	▲	▲	▲
RA110.5030.5.0	3	0.2	1.5	60	30	50	110260	▲	▲	▲	▲
LA110.2030.3.0	3	0.2	1.5	50	20	20	110260	▲	▲	▲	▲
LA110.2030.5.0	3	0.2	1.5	60	30	20	110260	▲	▲	▲	▲
LA110.5030.3.0	3	0.2	1.5	50	20	50	110260	▲	▲	▲	▲
LA110.5030.5.0	3	0.2	1.5	60	30	50	110260	▲	▲	▲	▲

These inserts are rotated at 17° and are only compatible with the holders on the previous pages. The holders are marked with a note.

Dimensions in mm

P	●	●	●	●
M	●	●	●	-
K	●	●	-	●
N	○	-	●	○
S	-	-	-	-
H	-	-	-	-

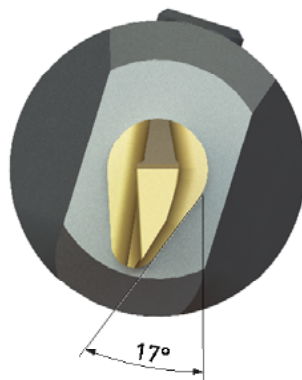

RA110 - RB110

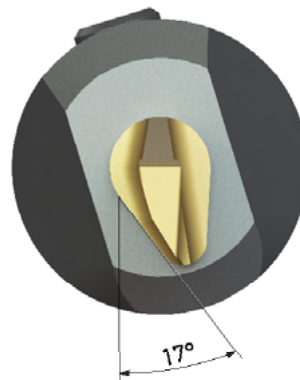

LA110 - LB110

C

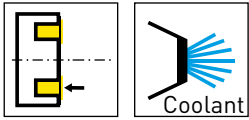

C

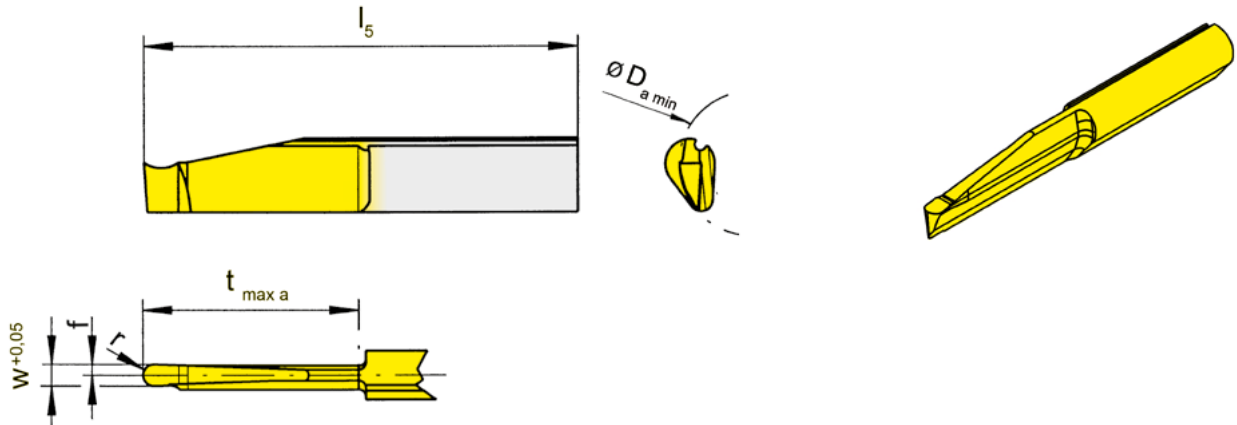

Coating grades

L = left hand version shown

R = right hand version

▲ In stock

Δ 2 weeks

Part number	w	r	f	l_5	$t_{\max a}$	$D_{a \min}$	HIS	EG35	TN35
RA110.2030.15.5.0	3	1.5	1.5	60	30	20	110260	▲	▲
LA110.2030.15.5.0	3	1.5	1.5	60	30	20	110260	▲	▲

These inserts are rotated at 17° and are only compatible with the holders on the previous pages. The holders are marked with a note.

Dimensions in mm

P	●	●
M	●	-
K	●	●
N	○	○
S	-	-
H	-	-

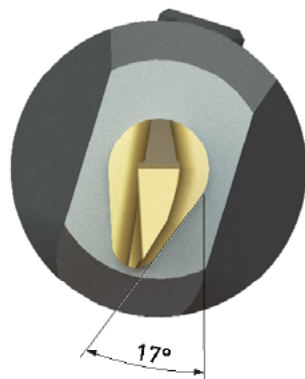

RA110 - RB110

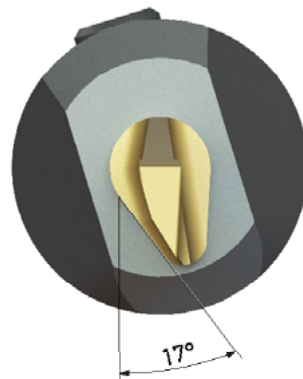

LA110 - LB110

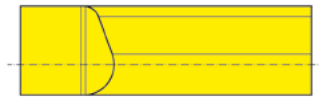
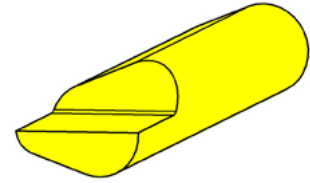
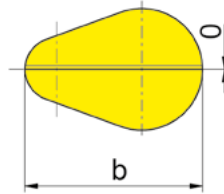
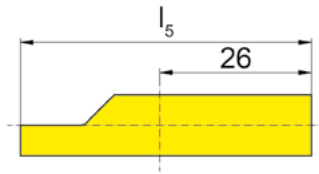
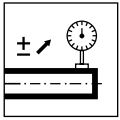

R = right hand version shown

L = left hand version

Part number	b	l_5	HIS
R110.LEHR.H02	10.3	40	110140
L110.LEHR.H02	10.3	40	110140

Setup and calibration insert

Dimensions in mm



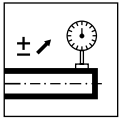

C

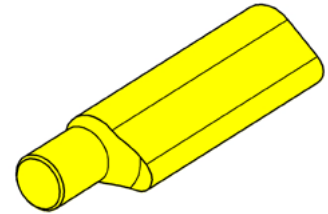
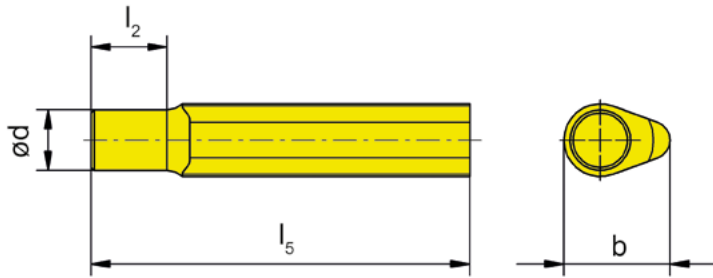

Part number	d	b	l_2	l_5	HIS
110.LEHR.D.01	5	10.3	5	25	110140

Setup and calibration insert

Dimensions in mm

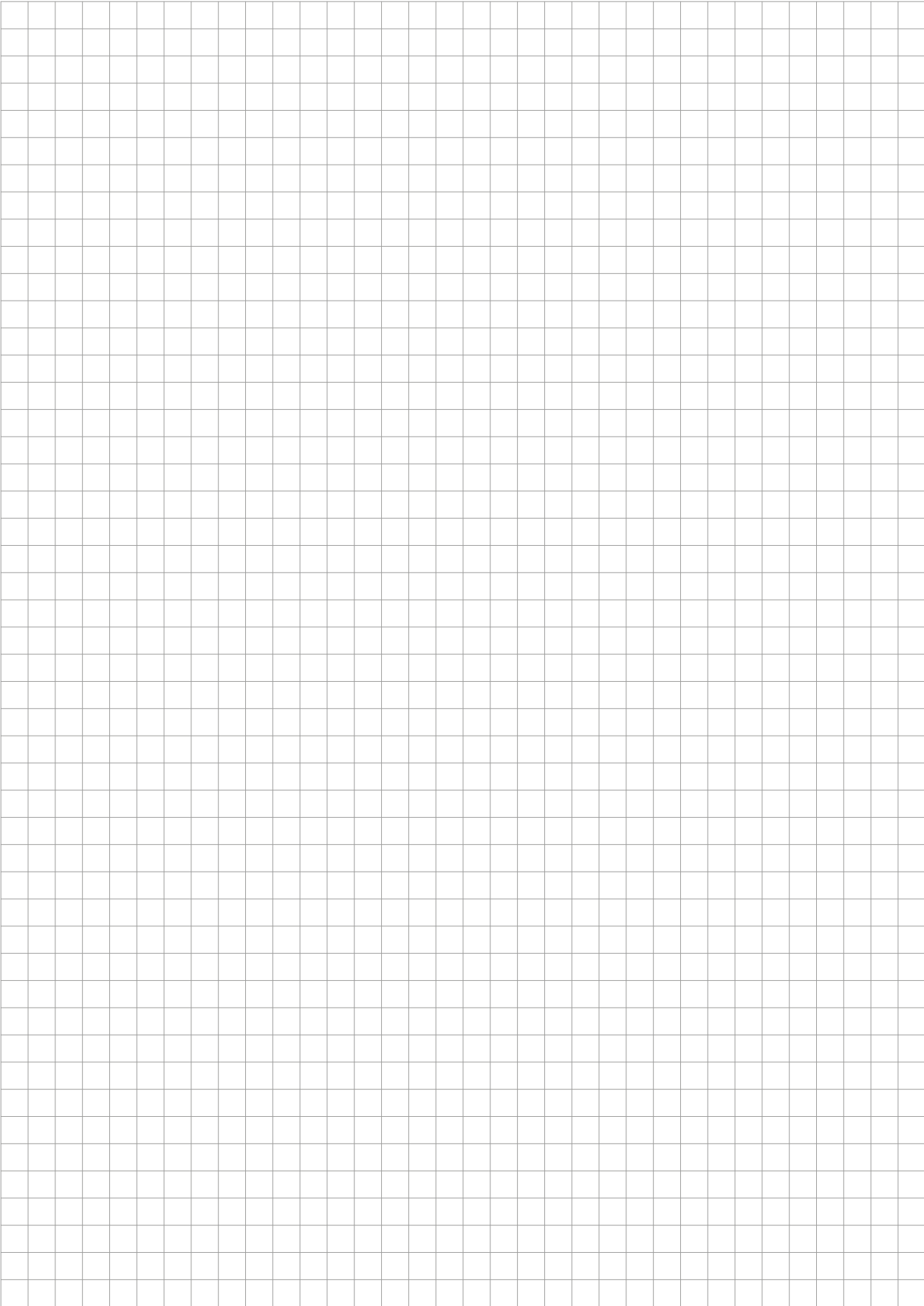



@HornUSAinc



Scan or click

**VISIT THE HORN USA YOUTUBE CHANNEL
FOR VIDEOS ON:**

Precision Tooling Education
High-Performance Application Demos
Tips and Tricks
In-depth Technical Discussions





D

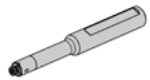
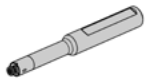

MINI 106

D

Bore Ø		Tool System											
mm	in	105	109	110	106	107	108	10P	111	11P	114	116	18P
≥ 0.2	≥ .0079	•											
≥ 0.5	≥ .0197	•											
≥ 0.7	≥ .0276	•											
≥ 1.0	≥ .0394	•											
≥ 1.5	≥ .0591	•											
≥ 2.0	≥ .0787	•											
≥ 3.0	≥ .1181	•											
≥ 4.0	≥ .1575	•											
≥ 5.0	≥ .1969	•											
≥ 6.0	≥ .2362	•	•	•	•								
≥ 6.8	≥ .2677		•	•	•								
≥ 7.0	≥ .2756		•			•							
≥ 7.8	≥ .3071			•		•	•						
≥ 8.0	≥ .3150			•		•	•						
≥ 9.0	≥ .3543			•		•	•	•					
≥ 10.0	≥ .3937			•				•	•	•			
≥ 10.5	≥ .4134									•			
≥ 11.0	≥ .4331								•	•			
≥ 11.5	≥ .4528									•			
≥ 13.8	≥ .5433										•		
≥ 14.0	≥ .5512										•	•	
≥ 16.0	≥ .6299									•		•	
≥ 16.5	≥ .6496										[•]		
≥ 18.0	≥ .7087												•
Depth of groove		2.5	2.5	4.0	0.8	2.0	1.0	3.0	2.3	3.5	4.0, (6.5)	4.3	8.0
		.0984	.0984	.1575	.0315	.0787	.0394	.1181	.0906	.1378	.1575, (.2559)	.1693	.3150
Width of groove		0.5-2.0	1.0-2.0	1.0-3.0	0.7-1.5	1.0-2.0	0.7-2.0	1.0-3.0	0.7-3.0	1.0-3.0	0.7-3.0	0.7-4.0	2.0-3.0
		.0197- .0787	.0394- .0787	.0394- .1181	.0276- .0591	.0394- .0787	.0276- .0787	.0394- .1181	.0276- .1181	.0394- .1181	.0276- .1181	.0276- .1575	.0787- .1181
Operations													
Grooving		•	•	•	•	•	•	•	•	•	•	•	•
Boring		•	•	•	•	•	•		•		•	•	
Threading		•	•			•	•		•		•	•	
Chamfering		•	•			•	•		•		•	•	
Face Grooving		•	•	•							•		
Boring and Profiling		•					•	•	•	•	•	•	

HOLDERS	Round Shank		
	 Page 237 Holder BU106 Inch Shank	 Page 238 Holder B106	
INSERTS	Boring	Grooving	
	 Page 239 Bore Contouring	 Page 240 Chamfering and Profiling	 Page 241 Grooving
	Cutting Data and Technical Instructions - Chapter M / Page 436		



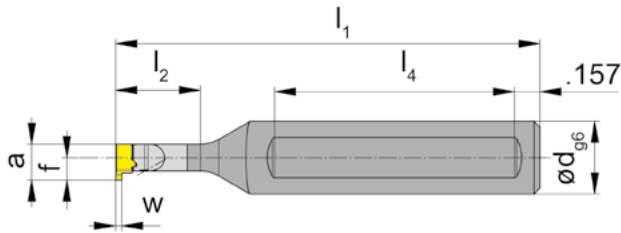
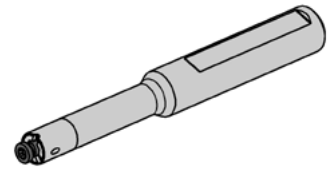
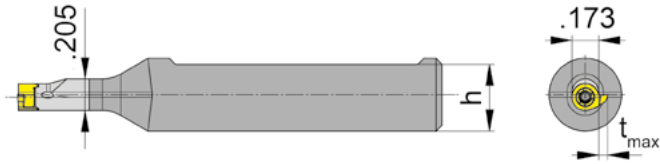
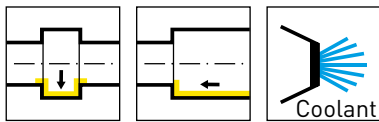

R = right hand version shown

L = left hand version

Part number	d	l ₁	l ₂	h	l ₄	HWS
RBU106.0500.01	.500	2.756	.551	.461	1.575	106044R
RBU106.0500.02	.500	3.150	.787	.461	1.575	106044R
RBU106.0500.03	.500	3.543	1.024	.461	1.772	106044R
LBU106.0500.01	.500	2.756	.551	.461	1.575	106044L
LBU106.0500.02	.500	3.150	.787	.461	1.575	106044L
LBU106.0500.03	.500	3.543	1.024	.461	1.772	106044L

For w, a, t_{max} and f dimensions, see insert pages

Dimensions in inch



Spare Parts

Toolholder	Clamping Screw	TORX PLUS® Wrench	Torque Value
R/LBU106...	1.8.4T6EP	T6PL	0.9 Nm

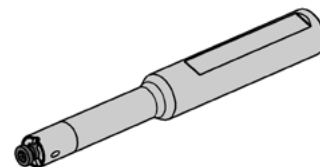
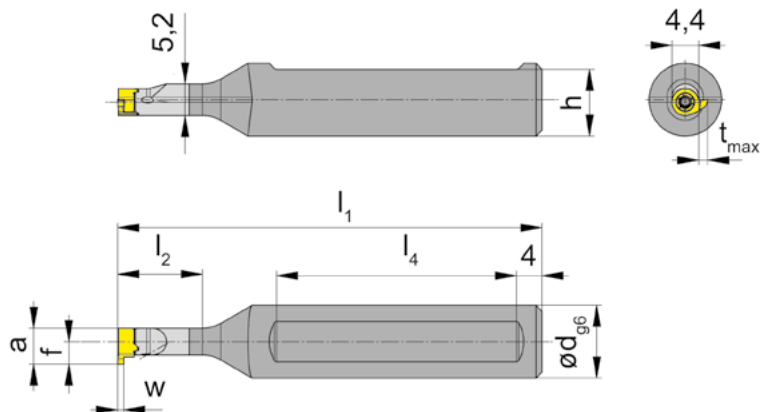
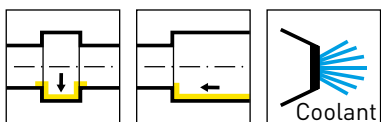

R = right hand version shown

L = left hand version

Part number	d	l ₁	l ₂	h	l ₄	HWS
RB106.0012.01	12	70	14	11	40	106044R
RB106.0012.02	12	80	20	11	40	106044R
RB106.0012.03	12	90	26	11	45	106044R
LB106.0012.01	12	70	14	11	40	106044L
LB106.0012.02	12	80	20	11	40	106044L
LB106.0012.03	12	90	26	11	45	106044L

For w, a, t_{max} and f dimensions, see insert pages

Dimensions in mm

Spare Parts

Toolholder	Clamping Screw	TORX PLUS® Wrench	Torque Value
R/LB106...	1.8.4T6EP	T6PL	0.9 Nm

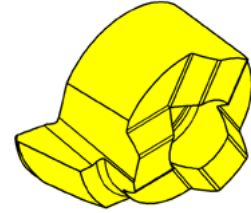
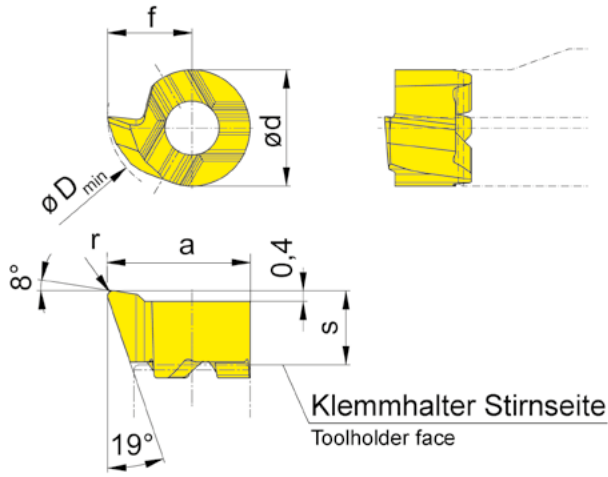
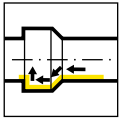

D

Coating grades

R = right hand version shown

L = left hand version

▲ In stock

△ 2 weeks

Part number	s	f	a	r	d	D _{min}	HIS	EG55	TH35
R106.1831.1.005	2.8	3.2	5.4	0.05	4.4	6	106044R	▲	▲
R106.1831.1.02	2.8	3.2	5.4	0.2	4.4	6	106044R	▲	▲
R106.1831.1.04	2.8	3.2	5.4	0.4	4.4	6	106044R	▲	▲
L106.1831.1.005	2.8	3.2	5.4	0.05	4.4	6	106044L	△	△
L106.1831.1.02	2.8	3.2	5.4	0.2	4.4	6	106044L	△	▲
L106.1831.1.04	2.8	3.2	5.4	0.4	4.4	6	106044L		▲

Dimensions in mm

	P	M	K	N	S	H
EG55	●	●	●	-	-	-
TH35	●	●	●	-	-	-

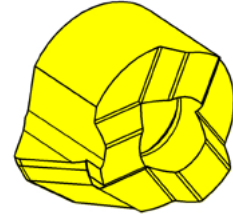
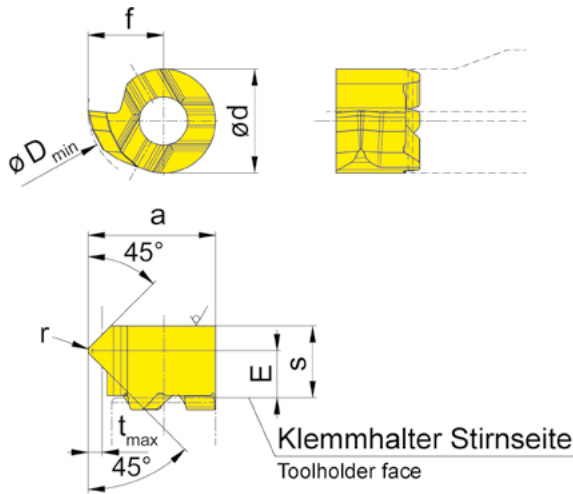
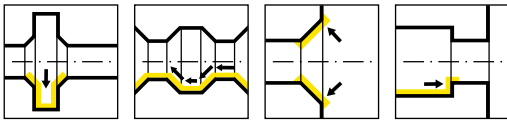

R = right hand version shown

L = left hand version

▲ In stock

Δ 2 weeks

Coating grades

Part number	E	s	f	a	r	d	t _{max}	D _{min}	HIS	EG55	TH35
R106.4545.1.02	2	3.05	3.2	5.4	0.2	4.4	0.6	6	106044R	▲	▲
L106.4545.1.02	2	3.05	3.2	5.4	0.2	4.4	0.6	6	106044L	Δ	

Dimensions in mm

P	●	●
M	●	●
K	●	●
N	-	-
S	-	-
H	-	-



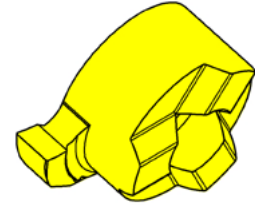
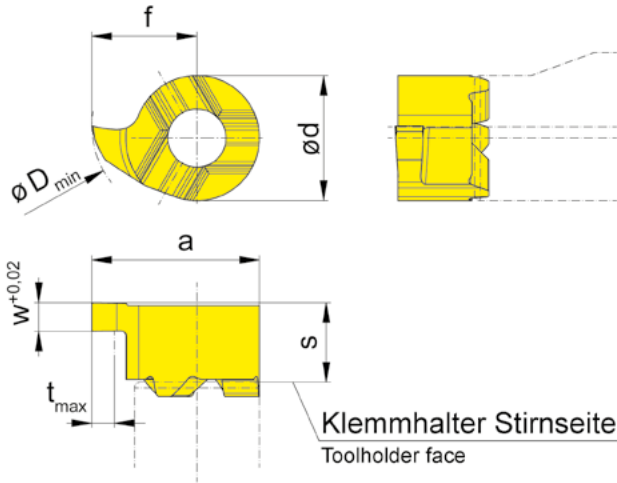
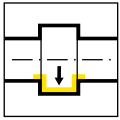

D

R = right hand version shown

L = left hand version

▲ In stock

Δ 2 weeks

Coating grades

Part number	w	s	f	a	d	t _{max}	D _{min}	HIS	EC55	TH35
R106.0150.2.00	1.5	2.8	3.7	5.9	4.4	0.8	6.5	106044R	Δ	▲
L106.0150.2.00	1.5	2.8	3.7	5.9	4.4	0.8	6.5	106044L	Δ	Δ

Dimensions in mm

P	●	●
M	●	●
K	●	●
N	-	-
S	-	-
H	-	-

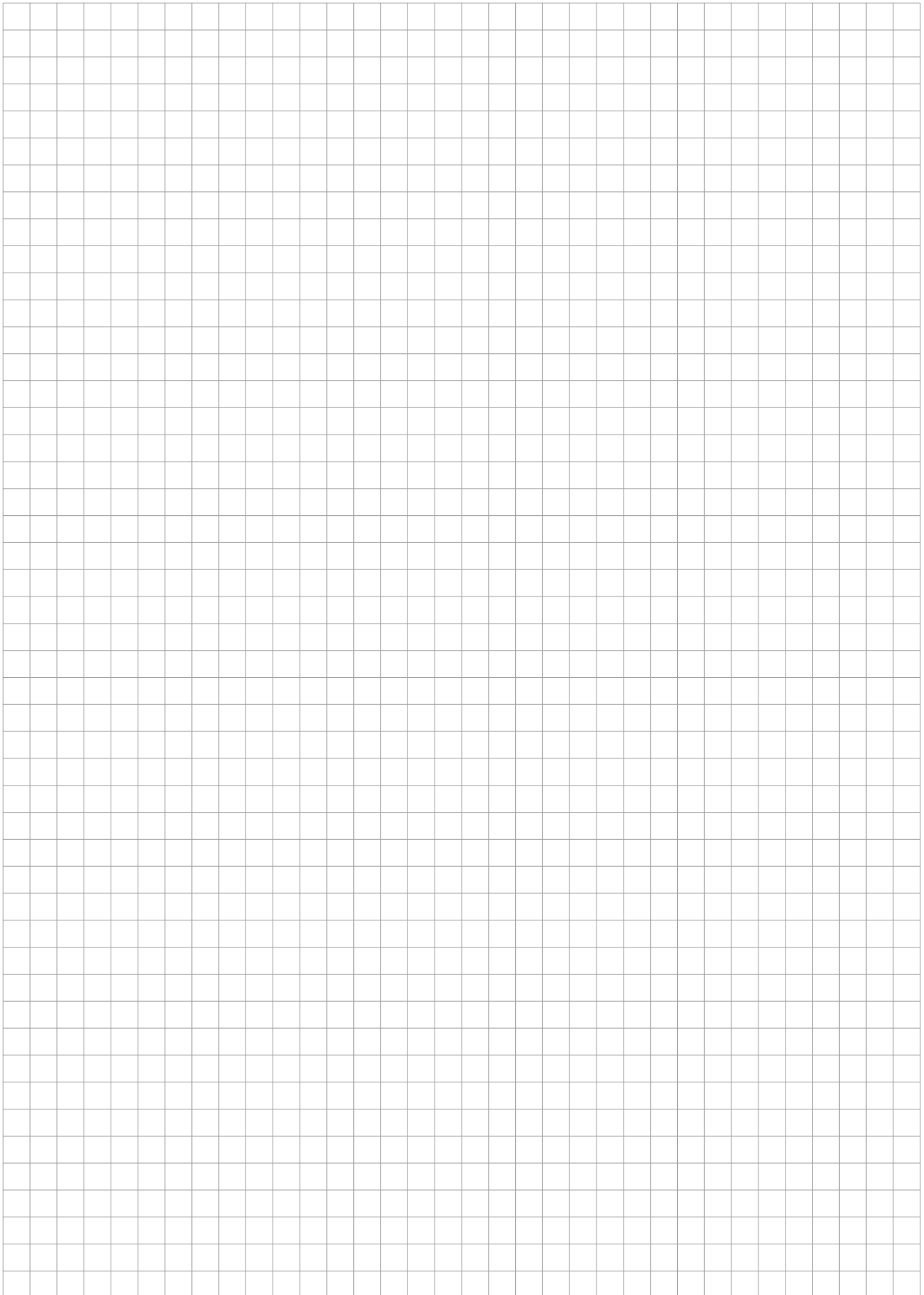

NEED SPECIAL TOOLS?



Scan or click

SCAN THE QR CODE ABOVE TO LEARN MORE ABOUT OUR SPECIAL PRODUCTS

Eligible US specials in 5 days with Greenline.

Available for all specialized applications.

Designed by machinists, for machinists.

E





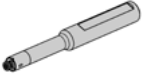
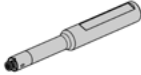

MINI 107

E

Bore Ø		Tool System											
mm	in	105	109	110	106	107	108	10P	111	11P	114	116	18P
≥ 0.2	≥ .0079	•											
≥ 0.5	≥ .0197	•											
≥ 0.7	≥ .0276	•											
≥ 1.0	≥ .0394	•											
≥ 1.5	≥ .0591	•											
≥ 2.0	≥ .0787	•											
≥ 3.0	≥ .1181	•											
≥ 4.0	≥ .1575	•											
≥ 5.0	≥ .1969	•											
≥ 6.0	≥ .2362	•	•	•	•								
≥ 6.8	≥ .2677		•	•	•								
≥ 7.0	≥ .2756		•			•							
≥ 7.8	≥ .3071			•		•	•						
≥ 8.0	≥ .3150			•		•	•						
≥ 9.0	≥ .3543			•		•	•	•					
≥ 10.0	≥ .3937			•				•	•	•			
≥ 10.5	≥ .4134									•			
≥ 11.0	≥ .4331								•	•			
≥ 11.5	≥ .4528									•			
≥ 13.8	≥ .5433										•		
≥ 14.0	≥ .5512										•	•	
≥ 16.0	≥ .6299									•		•	
≥ 16.5	≥ .6496										[•]		
≥ 18.0	≥ .7087												•
Depth of groove		2.5	2.5	4.0	0.8	2.0	1.0	3.0	2.3	3.5	4.0, (6.5)	4.3	8.0
		.0984	.0984	.1575	.0315	.0787	.0394	.1181	.0906	.1378	.1575, (.2559)	.1693	.3150
Width of groove		0.5-2.0	1.0-2.0	1.0-3.0	0.7-1.5	1.0-2.0	0.7-2.0	1.0-3.0	0.7-3.0	1.0-3.0	0.7-3.0	0.7-4.0	2.0-3.0
		.0197- .0787	.0394- .0787	.0394- .1181	.0276- .0591	.0394- .0787	.0276- .0787	.0394- .1181	.0276- .1181	.0394- .1181	.0276- .1181	.0276- .1575	.0787- .1181
Operations													
Grooving		•	•	•	•	•	•	•	•	•	•	•	•
Boring		•	•	•	•	•	•		•		•	•	
Threading		•	•			•	•		•		•	•	
Chamfering		•	•			•	•		•		•	•	
Face Grooving		•	•	•							•		
Boring and Profiling		•					•	•	•	•	•	•	

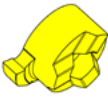
HOLDERS	Round Shank	
	 Page 247 Holder BU107 Inch Shank	 Page 248 Holder B107

INSERTS	Boring		Grooving	Threading
	 Page 249 Bore Contouring	 Page 250 Chamfering, Profiling, Back Boring	 Page 251-252 Grooving	 Page 253 Threading, 60° Partial Profile

Cutting Data and Technical Instructions - Chapter M / Page 436



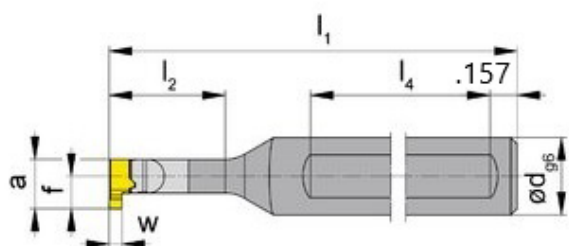
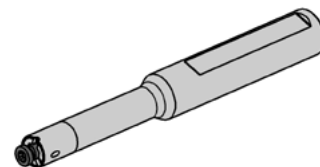
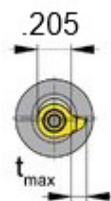
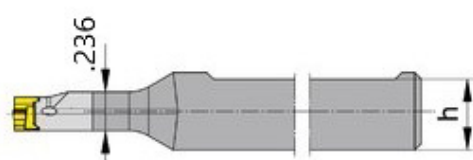
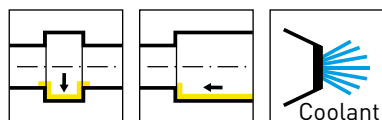

R = right hand version

L = left hand version

Part number	d	l ₁	l ₂	h	l ₄	HWS
RBU107.0500.01	.500	3.150	.709	.461	1.772	107052R
RBU107.0500.02	.500	3.543	1.024	.461	1.772	107052R
RBU107.0500.03	.500	3.937	1.417	.461	1.772	107052R
LBU107.0500.01	.500	3.150	.709	.461	1.772	107052L
LBU107.0500.02	.500	3.543	1.024	.461	1.772	107052L
LBU107.0500.03	.500	3.937	1.417	.461	1.772	107052L

For w, a, t_{max} and f dimensions, see insert pages

Dimensions in inch



Spare Parts

Toolholder	Clamping Screw	TORX PLUS® Wrench	Torque Value
R/LBU107...	2.2.5T7EP	T7PL	1.1 Nm

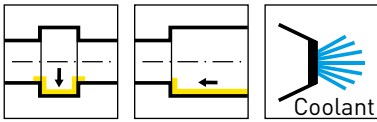

R = right hand version

L = left hand version

Part number	d	l ₁	l ₂	h	l ₄	HWS
RB107.0012.01	12	80	18	11	45	107052R
RB107.0012.02	12	90	26	11	45	107052R
RB107.0012.03	12	100	36	11	45	107052R
LB107.0012.01	12	80	18	11	45	107052L
LB107.0012.02	12	90	26	11	45	107052L
LB107.0012.03	12	100	36	11	45	107052L

For w, a, tmax and f dimensions, see insert pages

Dimensions in mm

Spare Parts

Toolholder	Clamping Screw	TORX PLUS® Wrench	Torque Value
R/LB107...	2.2.5T7EP	T7PL	1.1 Nm



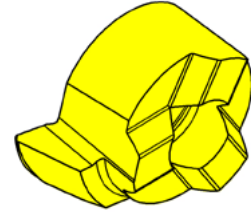
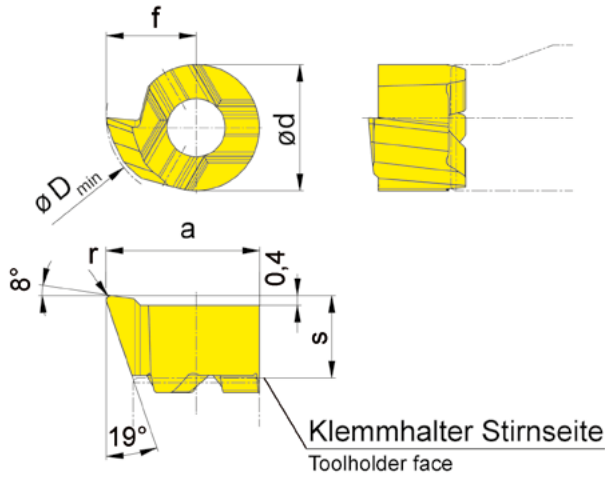
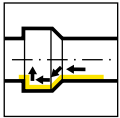

E

R = right hand version shown

L = left hand version

▲ In stock

Δ 2 weeks

Coating grades

Part number	s	f	a	r	d	D _{min}	HIS	EG55	TH35
R107.1837.02	3.3	3.7	6.3	0.2	5.2	6.8	107052R	▲	▲
R107.1837.04	3.3	3.7	6.3	0.4	5.2	6.8	107052R	▲	▲
L107.1837.02	3.3	3.7	6.3	0.2	5.2	6.8	107052L	▲	▲
L107.1837.04	3.3	3.7	6.3	0.4	5.2	6.8	107052L	▲	▲

Dimensions in mm

P	●	●
M	●	●
K	●	●
N	-	-
S	-	-
H	-	-

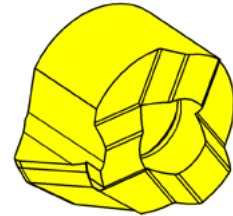
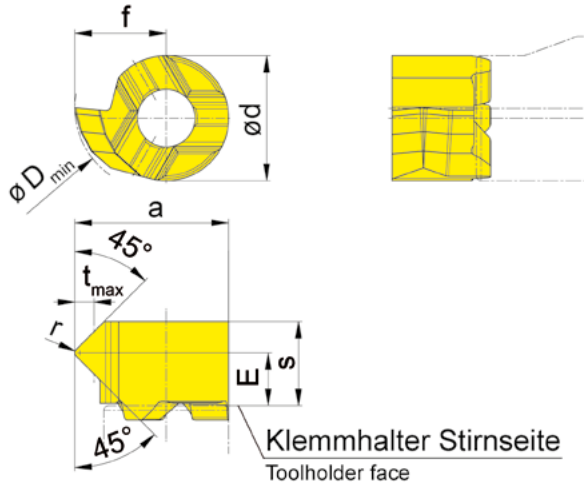
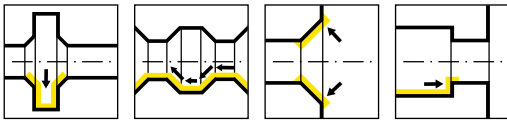

R = right hand version shown

L = left hand version

▲ In stock

Δ 2 weeks

Part number	E	s	f	a	r	d	t _{max}	D _{min}	HIS	EG55	TH35
R107.4545.1.02	2.2	3.5	3.8	6.4	0.2	5.2	0.8	6.8	107052R	▲	▲
L107.4545.1.02	2.2	3.5	3.8	6.4	0.2	5.2	0.8	6.8	107052L	Δ	▲

Dimensions in mm

P	●	●
M	●	●
K	●	●
N	-	-
S	-	-
H	-	-



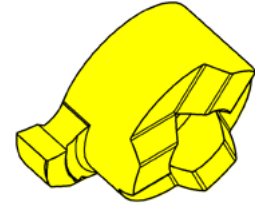
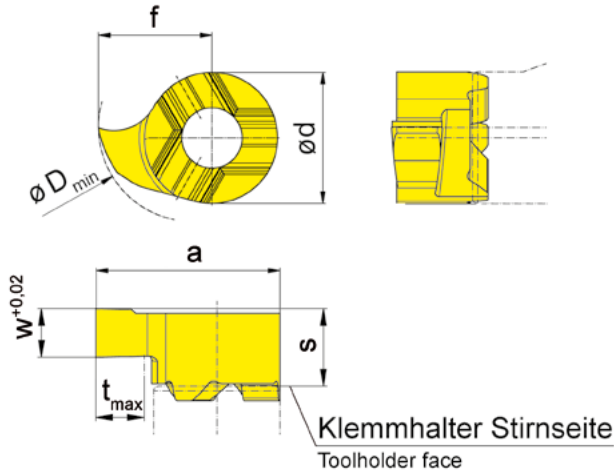
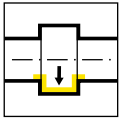

E

Coating grades

R = right hand version shown

L = left hand version

▲ In stock

Δ 2 weeks

Part number	w	s	f	a	d	t _{max}	D _{min}	HIS	EG55	TH35
R107.0100.1.00	1	3.3	4	6.6	5.2	1	7	107052R	▲	▲
R107.0150.1.00	1.5	3.3	4	6.6	5.2	1	7	107052R	▲	▲
L107.0100.1.00	1	3.3	4	6.6	5.2	1	7	107052L	Δ	▲
L107.0150.1.00	1.5	3.3	4	6.6	5.2	1	7	107052L	Δ	▲

Dimensions in mm

P	●	●
M	●	●
K	●	●
N	-	-
S	-	-
H	-	-

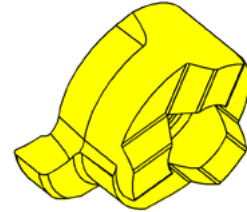
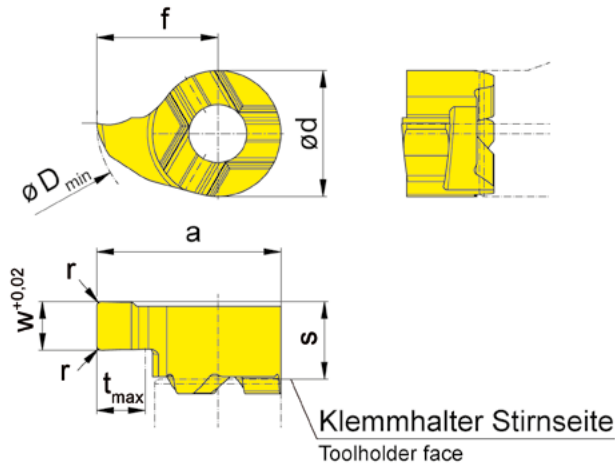
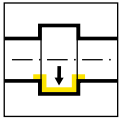

R = right hand version shown

L = left hand version

▲ In stock

Δ 2 weeks

Coating grades

Part number	w	s	f	a	r	d	t _{max}	D _{min}	HIS	EG55	TH35
R107.0100.2.00	1	3.3	5	7.6	-	5.2	2	8	107052R	▲	▲
R107.0150.2.01	1.5	3.3	5	7.6	0.1	5.2	2	8	107052R	▲	▲
R107.0200.2.02	2	3.3	5	7.6	0.2	5.2	2	8	107052R	▲	▲
L107.0100.2.00	1	3.3	5	7.6	-	5.2	2	8	107052L	Δ	▲
L107.0150.2.01	1.5	3.3	5	7.6	0.1	5.2	2	8	107052L	Δ	▲
L107.0200.2.02	2	3.3	5	7.6	0.2	5.2	2	8	107052L	Δ	▲

Inserts ending in "...00" have sharp corners with no radius

Dimensions in mm

P	●	●
M	●	●
K	●	●
N	-	-
S	-	-
H	-	-



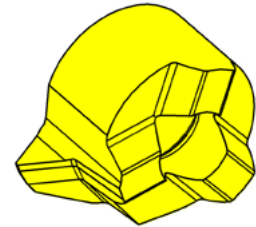
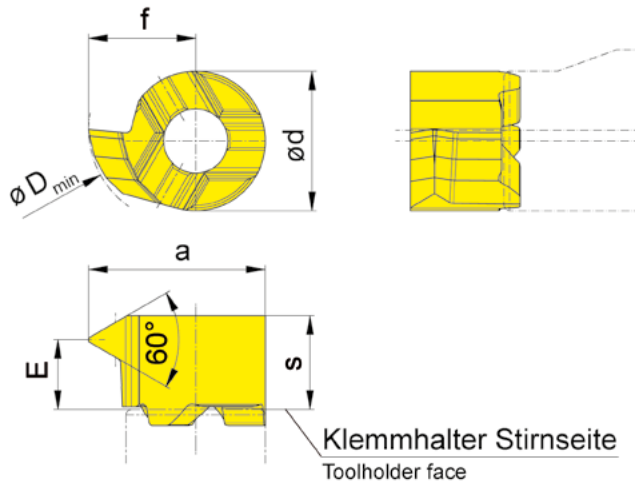
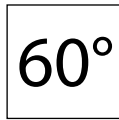
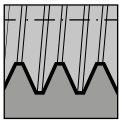

Klemmhalter Stirnseite
Toolholder face

Coating grades

R = right hand version shown

L = left hand version

▲ In stock

△ 2 weeks

Part number	P	TPI	TPI _{max}	E	f	a	d	s	D _{min}	HIS	EG55	TH35
R107.0205.1.01	0.5	28	64	3	4	6.6	5.2	3.5	7	107052R	▲	▲
R107.0510.1.01	1	18	32	2.8	4	6.6	5.2	3.5	7	107052R	▲	▲
R107.0815.1.01	1.5	12	20	2.6	4	6.6	5.2	3.5	7	107052R	▲	▲
L107.0205.1.01	0.5	28	64	3	4	6.6	5.2	3.5	7	107052L	△	▲
L107.0510.1.01	1	18	32	2.8	4	6.6	5.2	3.5	7	107052L	△	▲
L107.0815.1.01	1.5	28	64	2.6	4	6.6	5.2	3.5	7	107052L	△	▲

Dimensions in mm

	P	M	K	N	S	H
EG55	●	●	●	-	-	-
TH35	●	●	●	-	-	-



F

MINI 108

F

Bore Ø		Tool System											
mm	in	105	109	110	106	107	108	10P	111	11P	114	116	18P
≥ 0.2	≥ .0079	•											
≥ 0.5	≥ .0197	•											
≥ 0.7	≥ .0276	•											
≥ 1.0	≥ .0394	•											
≥ 1.5	≥ .0591	•											
≥ 2.0	≥ .0787	•											
≥ 3.0	≥ .1181	•											
≥ 4.0	≥ .1575	•											
≥ 5.0	≥ .1969	•											
≥ 6.0	≥ .2362	•	•	•	•								
≥ 6.8	≥ .2677		•	•	•								
≥ 7.0	≥ .2756		•			•							
≥ 7.8	≥ .3071			•		•	•						
≥ 8.0	≥ .3150			•		•	•						
≥ 9.0	≥ .3543			•		•	•	•					
≥ 10.0	≥ .3937			•				•	•	•			
≥ 10.5	≥ .4134									•			
≥ 11.0	≥ .4331								•	•			
≥ 11.5	≥ .4528									•			
≥ 13.8	≥ .5433										•		
≥ 14.0	≥ .5512										•	•	
≥ 16.0	≥ .6299									•		•	
≥ 16.5	≥ .6496										[•]		
≥ 18.0	≥ .7087												•
Depth of groove		2.5	2.5	4.0	0.8	2.0	1.0	3.0	2.3	3.5	4.0, (6.5)	4.3	8.0
		.0984	.0984	.1575	.0315	.0787	.0394	.1181	.0906	.1378	.1575, (.2559)	.1693	.3150
Width of groove		0.5-2.0	1.0-2.0	1.0-3.0	0.7-1.5	1.0-2.0	0.7-2.0	1.0-3.0	0.7-3.0	1.0-3.0	0.7-3.0	0.7-4.0	2.0-3.0
		.0197- .0787	.0394- .0787	.0394- .1181	.0276- .0591	.0394- .0787	.0276- .0787	.0394- .1181	.0276- .1181	.0394- .1181	.0276- .1181	.0276- .1575	.0787- .1181
Operations													
Grooving		•	•	•	•	•	•	•	•	•	•	•	•
Boring		•	•	•	•	•	•		•		•	•	
Threading		•	•			•	•		•		•	•	
Chamfering		•	•			•	•		•		•	•	
Face Grooving		•	•	•							•		
Boring and Profiling		•					•	•	•	•	•	•	

HOLDERS

Round Shank

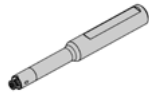

Page 257
Holder BU108
Inch Shank

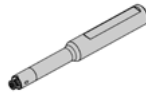

Page 258
Holder B108

INSERTS

Boring

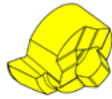

Page 259
Bore Contouring

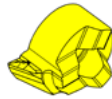

Page 260
Boring
.I Chipbreaker

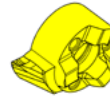

Page 261
Bore Contouring
.R Chipbreaker



Page 262-263
Bore Contouring
and Profiling



Page 264
Back Boring



Page 265
Chamfering and
Profiling

Grooving



Page 266
Grooving
Inch



Page 267-269
Grooving

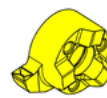

Page 270
Grooving
.D Chipbreaker

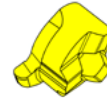

Page 271
Grooving
Full Radius, Inch

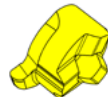

Page 272
Grooving
Full Radius

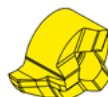

Page 273
Per-Part Off



Page 274-275
Fine Finishing

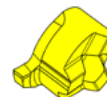

Page 276
Fine Finishing
.FB Geometry

Threading



Page 277
Threading, 60°
Partial Profile



Page 278
Threading, 60°
.GM Chipbreaker, Partial

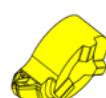

Page 279
Threading, 60°
.GM Chipbreaker, Full

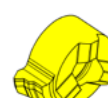

Page 280-281
Threading
NPT and PG

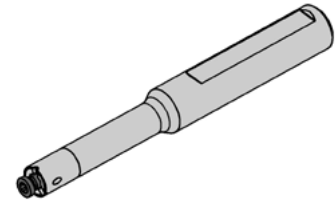
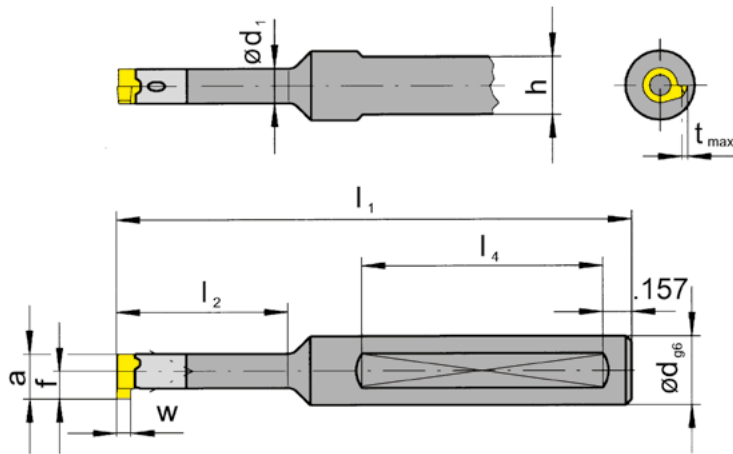
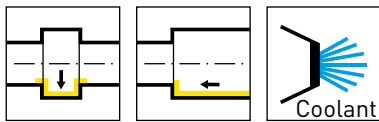

Picture = right hand insert shown

F

Part number	d	l_1	l_2	h	l_4	d_1	HWS
BU108.ST05.00	.500	2.756	.492	.460	1.575	.236	108060R • 108060L
BU108.0500.01	.500	3.150	.827	.460	1.772	.236	108060R • 108060L
BU108.0500.02	.500	3.543	1.181	.460	1.772	.236	108060R • 108060L
BU108.0500.03	.500	3.937	1.654	.460	1.772	.236	108060R • 108060L

Holders with ".ST" are steel shanks

For w, a, t_{max} and f dimensions, see insert pages

Dimensions in inch



Spare Parts

Toolholder	Clamping Screw	TORX PLUS® Wrench	Torque Value
BU108...	2.6.5T8EP	T8PL	1.2 Nm

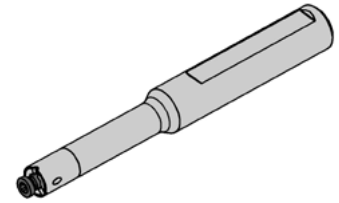
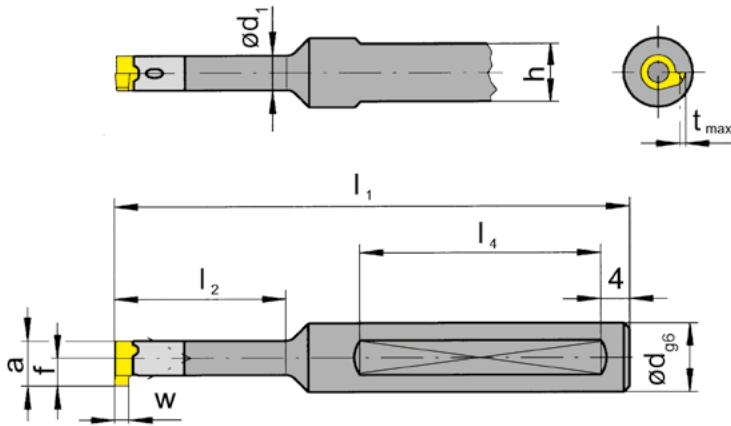
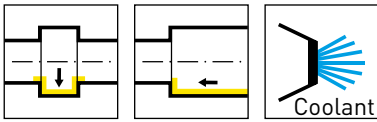

Picture = right hand insert shown

Part number	d	l_1	l_2	h	l_4	d_1	HWS
B108.0006.01A	6	65	-	-	-	-	108060R • 108060L
B108.0008.00	8	60	12.5	7	35	6	108060R • 108060L
B108.0008.01	8	70	21	7	40	6	108060R • 108060L
B108.0012.00	12	70	12.5	11	40	6	108060R • 108060L
B108.0012.01	12	80	21	11	45	6	108060R • 108060L
B108.0012.02	12	90	30	11	45	6	108060R • 108060L
B108.0012.03	12	100	42	11	45	6	108060R • 108060L

B108.0006.01A is a round shaft with no neck reduction or clamping flat

For w, a, t_{max} and f dimensions, see insert pages

Dimensions in mm

Spare Parts

Toolholder	Clamping Screw	TORX PLUS® Wrench	Torque Value
B108...	2.6.5T8EP	T8PL	1.2 Nm



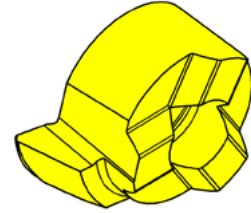
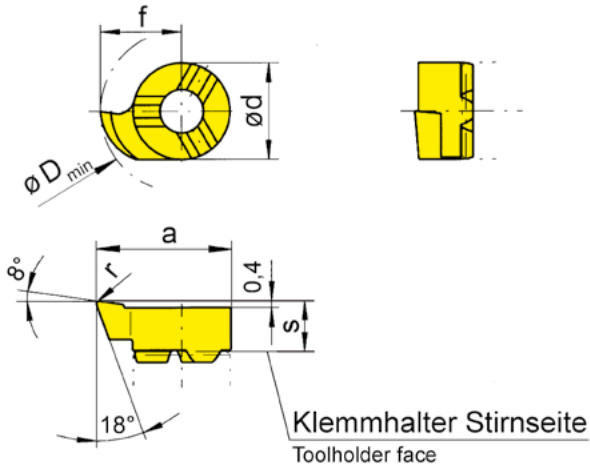
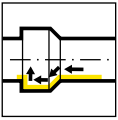

Coating grades

R = right hand version shown

L = left hand version

▲ In stock

Δ 2 weeks

F

Part number	s	f	a	r	d	D _{min}	HIS	EG55	IG35	TH35	TI25	TN35
R108.1846.02	3.4	4.65	7.65	0.2	6	7.8	108060R	▲	▲	▲	▲	▲
L108.1846.02	3.4	4.65	7.65	0.2	6	7.8	108060L	▲	▲	▲	▲	▲

Dimensions in mm

P	●	●	●	●	●
M	●	●	●	●	-
K	●	●	●	-	●
N	-	○	-	●	○
S	-	○	-	-	-
H	-	-	-	-	-

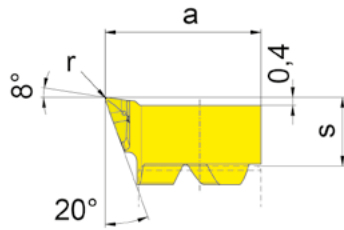
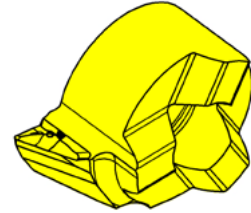
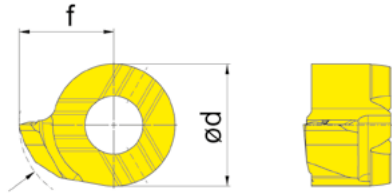
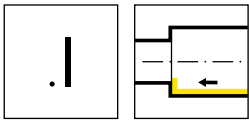

R = right hand version shown

L = left hand version

▲ In stock

Δ 2 weeks

Coating grades

Part number	s	f	a	r	d	D _{min}	HIS	Coating grades			
								EG35	EG55	IG35	
RS108.0820.105	3.37	4.65	7.65	0.05	6	7.8	108060R			Δ	
RS108.0820.110	3.38	4.65	7.65	0.1	6	7.8	108060R	▲		▲	
RS108.0820.120	3.4	4.65	7.65	0.2	6	7.8	108060R		▲	▲	
								P	●	●	●
								M	●	●	●
								K	●	●	●
								N	○	-	○
								S	-	-	○
								H	-	-	-

Dimensions in mm



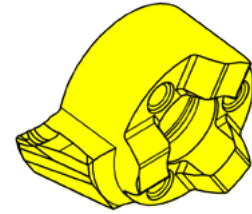
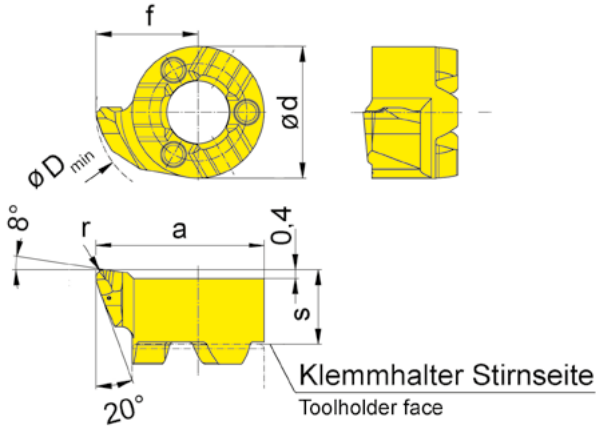
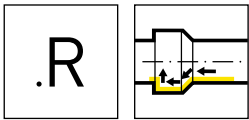

Coating grades

R = right hand version shown

L = left hand version

▲ In stock

Δ 2 weeks

F

Part number	s	f	a	r	d	D _{min}	HIS	EG55	TH35
RS108.1846.R2	3.4	4.65	7.65	0.2	6	7.8	108060R	▲	▲
RS108.1846.R4	3.4	4.65	7.65	0.4	6	7.8	108060R	▲	▲
LS108.1846.R2	3.4	4.65	7.65	0.2	6	7.8	108060L	▲	▲
LS108.1846.R4	3.4	4.65	7.65	0.4	6	7.8	108060L	▲	▲

Dimensions in mm

P	●	●
M	●	●
K	●	●
N	-	-
S	-	-
H	-	-

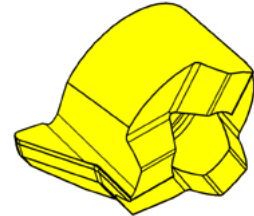
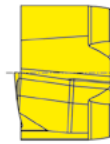
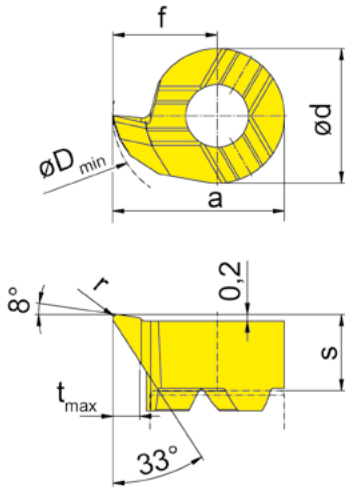
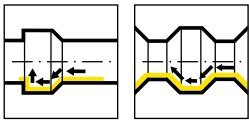

Coating grades

R = right hand version shown

L = left hand version

▲ In stock

Δ 2 weeks

Part number	s	f	a	r	d	t _{max}	D _{min}	HIS	EG55
R108.3348.01	3.4	4.65	7.65	0.1	6	1.2	7.8	108060R	▲
R108.3348.02	3.4	4.65	7.65	0.2	6	1.2	7.8	108060R	▲
R108.3348.04	3.4	4.65	7.65	0.4	6	1.2	7.8	108060R	▲
L108.3348.01	3.4	4.65	7.65	0.1	6	1.2	7.8	108060L	
L108.3348.02	3.4	4.65	7.65	0.2	6	1.2	7.8	108060L	
L108.3348.04	3.4	4.65	7.65	0.4	6	1.2	7.8	108060L	

Dimensions in mm

P	●
M	●
K	●
N	-
S	-
H	-



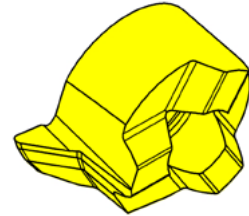
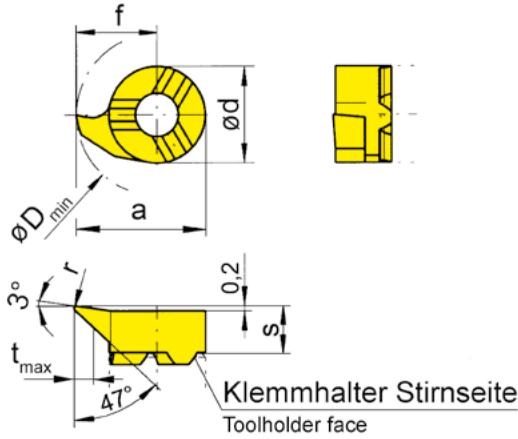
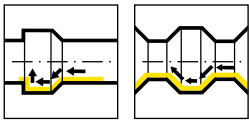

Coating grades

R = right hand version shown

L = left hand version

▲ In stock

Δ 2 weeks

F

Part number	s	f	a	r	d	t _{max}	D _{min}	HIS	Coating grades			
									EG55	IG35	TH35	TN35
R108.4748.01	3.2	4.65	7.65	0.1	6	1.2	7.8	108060R	▲	▲	▲	
R108.4748.02	3.2	4.65	7.65	0.2	6	1.2	7.8	108060R	▲	▲	▲	▲
R108.4748.04	3.2	4.65	7.65	0.4	6	1.2	7.8	108060R	▲		▲	
L108.4748.01	3.2	4.65	7.65	0.1	6	1.2	7.8	108060L	▲	▲	▲	
L108.4748.02	3.2	4.65	7.65	0.2	6	1.2	7.8	108060L	▲	▲	▲	▲
L108.4748.04	3.2	4.65	7.65	0.4	6	1.2	7.8	108060L	▲		▲	

Dimensions in mm

	P	M	K	N	S	H
EG55	●	●	●	-	-	-
IG35	●	●	●	○	○	-
TH35	●	●	●	-	-	-
TN35	●	-	●	○	-	-

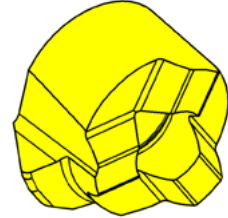
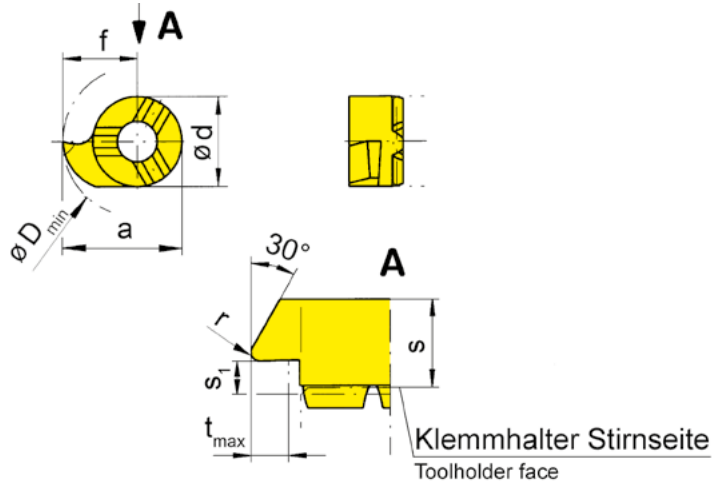
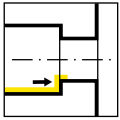

Coating grades

R = right hand version shown

L = left hand version

▲ In stock

Δ 2 weeks

Part number	s	f	a	r	s ₁	d	t _{max}	D _{min}	HIS	EG55	IG35	TH35	TN35
R108.3046.02	3.6	4.65	7.65	0.2	0.8	6	1.3	7.8	108060R	▲	▲	▲	▲
L108.3046.02	3.6	4.65	7.65	0.2	0.8	6	1.3	7.8	108060L	Δ	▲	▲	▲
										P	●	●	●
										M	●	●	-
										K	●	●	●
										N	-	○	○
										S	-	○	-
										H	-	-	-

Dimensions in mm



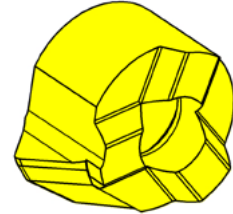
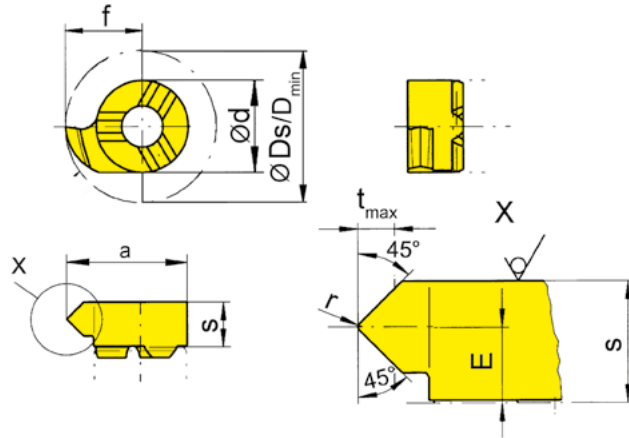
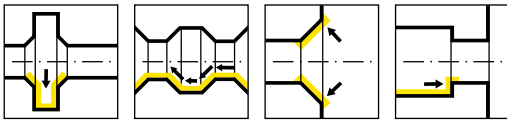

Coating grades

R = right hand version shown

L = left hand version

▲ In stock

Δ 2 weeks

F

Part number	E	f	Ds	r	d	s	a	D _{min}	a	t _{max}	Z	HIS	EG55	IG35	TA45	TI25	TN35
R108.4545.02	1.8	4.65	9.3	0.2	6	3.6	7.65	7.8	45°	1.4	1	108060R	▲	▲	▲	▲	▲
L108.4545.02	1.8	4.65	9.3	0.2	6	3.6	7.65	7.8	45°	1.4	1	108060L	▲			Δ	▲

Dimensions in mm

P	●	●	●	●	●
M	●	●	●	●	-
K	●	●	●	-	●
N	-	○	●	●	○
S	-	○	●	-	-
H	-	-	-	-	-

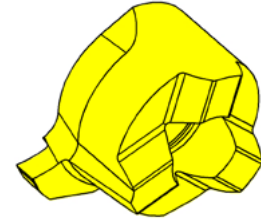
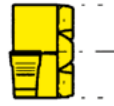
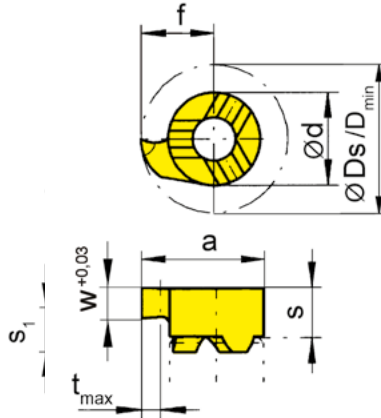
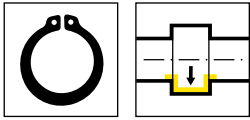

Coating grades

R = right hand version shown

L = left hand version

▲ In stock

Δ 2 weeks

Part number	w	s	f	a	d	t _{max}	D _{min}	HIS	MG12	IG35	TH35	TN35
RU108.0031.00	.031	.142	.189	.307	.236	.039	.315	108060R	Δ	▲	▲	▲
RU108.0039.00	.039	.142	.189	.307	.236	.039	.315	108060R		▲	▲	▲
RU108.0046.00	.046	.126	.189	.307	.236	.039	.315	108060R	▲	▲	▲	▲
RU108.0056.00	.056	.126	.189	.307	.236	.039	.315	108060R		▲	▲	▲
RU108.0062.00	.062	.126	.189	.307	.236	.039	.315	108060R	▲	▲	▲	▲
RU108.0078.00	.078	.126	.189	.307	.236	.039	.315	108060R		▲	▲	▲
LU108.0031.00	.031	.142	.189	.307	.236	.039	.315	108060L		▲		▲
LU108.0056.00	.056	.126	.189	.307	.236	.039	.315	108060L		▲		▲
LU108.0062.00	.062	.126	.189	.307	.236	.039	.315	108060L				▲
LU108.0078.00	.078	.126	.189	.307	.236	.039	.315	108060L		▲		▲

Dimensions in inch



P	-	●	●	●
M	-	●	●	-
K	-	●	●	●
N	●	○	-	○
S	-	○	-	-
H	-	-	-	-



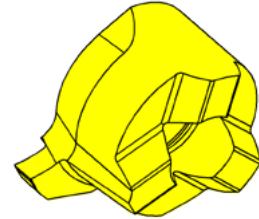
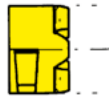
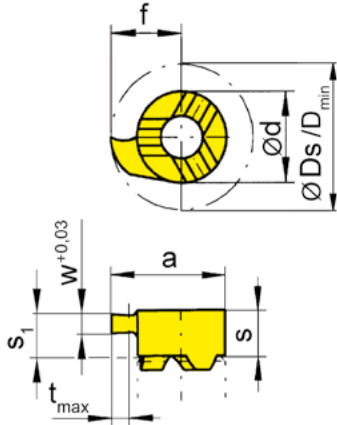
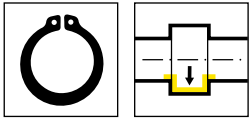

Coating grades

R = right hand version shown

L = left hand version

▲ In stock

△ 2 weeks

F

Part number	w	f	Ds	d	s	s ₁	a	t _{max}	D _{min}	HIS	EG55	IG35	TH35	TN35
R108.0070.00	0.74	4.8	9.6	6	3.6	3.2	7.8	1	8	108060R	▲	▲	▲	▲
R108.0080.00	0.84	4.8	9.6	6	3.6	3.2	7.8	1	8	108060R	▲		▲	▲
R108.0090.00	0.94	4.8	9.6	6	3.6	3.2	7.8	1	8	108060R	▲		▲	▲
L108.0070.00	0.74	4.8	9.6	6	3.6	3.2	7.8	1	8	108060L	△		▲	▲
L108.0080.00	0.84	4.8	9.6	6	3.6	3.2	7.8	1	8	108060L	△	▲	▲	▲
L108.0090.00	0.94	4.8	9.6	6	3.6	3.2	7.8	1	8	108060L	▲		▲	▲

Not face cutting, limited depth of cut

Dimensions in mm

P	●	●	●	●
M	●	●	●	-
K	●	●	●	●
N	-	○	-	○
S	-	○	-	-
H	-	-	-	-

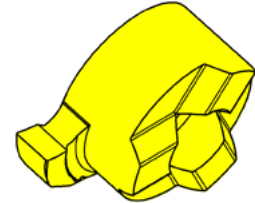
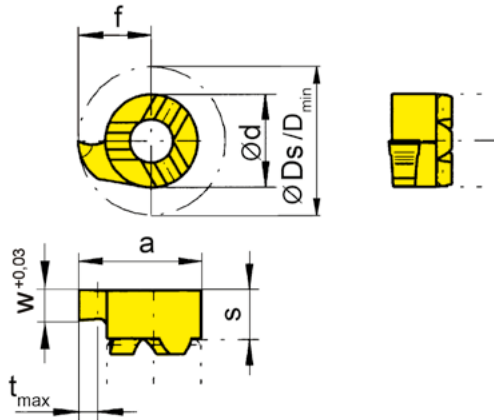
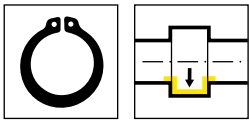

Coating grades

R = right hand version shown

L = left hand version

▲ In stock

Δ 2 weeks

Part number	w	s	f	Ds	a	d	t _{max}	D _{min}	HIS	Coating grades		
										EG55	TH35	TN35
R108.0110.00	1.19	3.2	4.8	9.6	7.8	6	1	8	108060R	▲	▲	▲
R108.0160.00	1.69	3.2	4.8	9.6	7.8	6	1	8	108060R	▲	▲	▲
R108.0130.00	1.39	3.2	4.8	9.6	7.8	6	1	8	108060R	▲	▲	▲
L108.0110.00	1.19	3.2	4.8	9.6	7.8	6	1	8	108060L	▲	▲	▲
L108.0160.00	1.69	3.2	4.8	9.6	7.8	6	1	8	108060L	▲	Δ	▲
L108.0130.00	1.39	3.2	4.8	9.6	7.8	6	1	8	108060L		Δ	▲

Dimensions in mm

	P	M	K	N	S	H
EG55	●	●	●	-	-	-
TH35	●	●	●	-	-	-
TN35	●	-	●	○	-	-



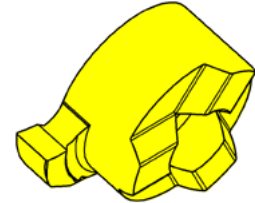
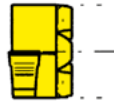
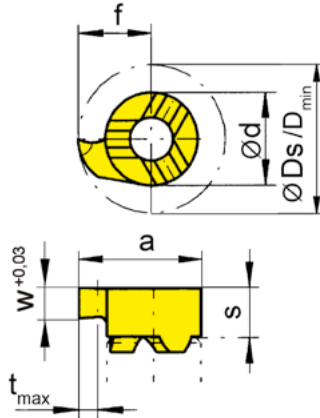
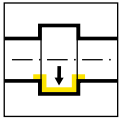

Coating grades

R = right hand version shown

L = left hand version

▲ In stock

Δ 2 weeks

F

Part number	w	s	f	Ds	a	d	t _{max}	D _{min}	Z	HIS	Coating grades			
											EG55	IG35	TH35	TN35
R108.0150.00	1.5	3.2	4.8	9.6	7.8	6	1	8	1	108060R	▲		▲	▲
R108.0200.00	2	3.2	4.8	9.6	7.8	6	1	8	1	108060R	▲	▲	▲	▲
L108.0150.00	1.5	3.2	4.8	9.6	7.8	6	1	8	1	108060L			▲	▲
L108.0200.00	2	3.2	4.8	9.6	7.8	6	1	8	1	108060L			▲	▲

Dimensions in mm

P	●	●	●	●
M	●	●	●	-
K	●	●	●	●
N	-	○	-	○
S	-	○	-	-
H	-	-	-	-

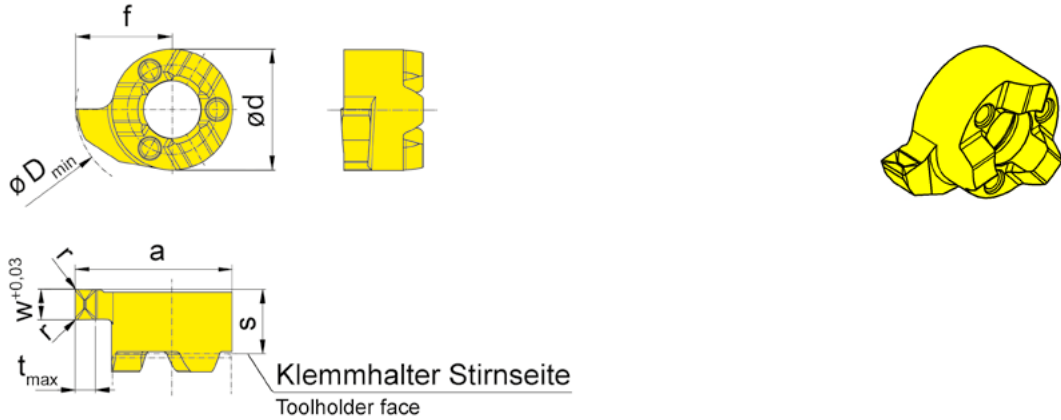
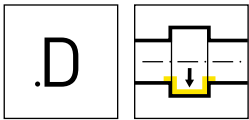

Coating grades

R = right hand version shown

L = left hand version

▲ In stock

Δ 2 weeks

Part number	w	s	f	a	r	d	t _{max}	D _{min}	HIS	EG55	TH35
RS108.0100.D1	1	3.2	4.8	7.8	0.1	6	1	8	108060R	▲	▲
RS108.0150.D1	1.5	3.2	4.8	7.8	0.1	6	1	8	108060R	▲	▲
RS108.0200.D2	2	3.2	4.8	7.8	0.2	6	1	8	108060R	▲	▲
LS108.0100.D1	1	3.2	4.8	7.8	0.1	6	1	8	108060L	Δ	▲
LS108.0150.D1	1.5	3.2	4.8	7.8	0.1	6	1	8	108060L	Δ	▲
LS108.0200.D2	2	3.2	4.8	7.8	0.2	6	1	8	108060L	Δ	▲

Dimensions in mm

P	●	●
M	●	●
K	●	●
N	-	-
S	-	-
H	-	-



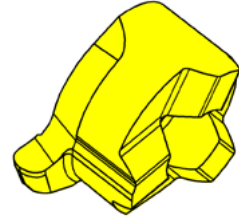
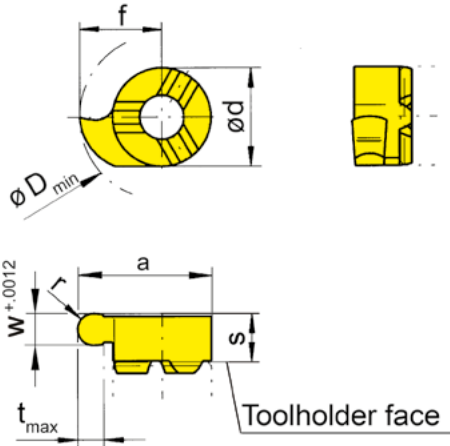
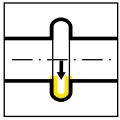

Coating grades

R = right hand version shown

L = left hand version

▲ In stock

Δ 2 weeks

F

Part number	w	s	f	a	r	d	t _{max}	D _{min}	HIS		MG12	IG35	TF45	TH35	TN35
RU108.0015.31	.031	.126	.189	.307	.016	.236	.039	.315	108060R			▲		▲	▲
RU108.0023.46	.046	.126	.189	.307	.023	.236	.039	.315	108060R			▲		▲	▲
RU108.0031.62	.062	.126	.189	.307	.032	.236	.039	.315	108060R		▲	▲		▲	▲
RU108.0039.78	.078	.126	.189	.307	.039	.236	.039	.315	108060R			▲	▲	▲	▲
LU108.0015.31	.031	.126	.189	.307	.016	.236	.039	.315	108060L			▲		▲	▲
LU108.0023.46	.046	.126	.189	.307	.023	.236	.039	.315	108060L			▲		▲	▲
LU108.0031.62	.062	.126	.189	.307	.032	.236	.039	.315	108060L			▲		▲	▲
LU108.0039.78	.078	.126	.189	.307	.039	.236	.039	.315	108060L			▲		▲	▲
											P	-	●	-	●
											M	-	●	-	●
											K	-	●	-	●
											N	●	○	-	-
											S	-	○	-	-
											H	-	-	-	-

Dimensions in inch



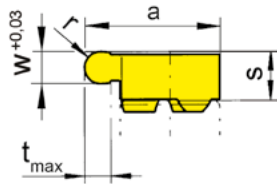
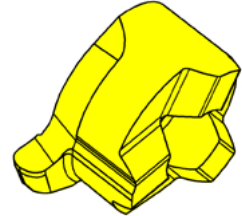
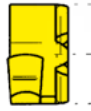
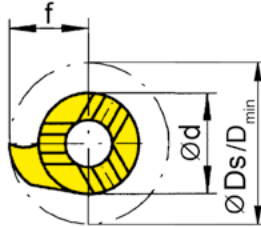
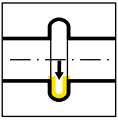

Coating grades

R = right hand version shown

L = left hand version

▲ In stock

Δ 2 weeks

Part number	w	s	f	Ds	a	r	d	t _{max}	D _{min}	Z	HIS	EG55	IG35	TH35	TN35
R108.0004.08	0.8	3.2	4.8	9.6	7.8	0.4	6	1	8	1	108060R	▲	▲	▲	▲
R108.0006.12	1.2	3.2	4.8	9.6	7.8	0.6	6	1	8	1	108060R	▲		▲	▲
R108.0009.18	1.8	3.2	4.8	9.6	7.8	0.9	6	1	8	1	108060R	▲	▲	▲	▲
L108.0004.08	0.8	3.2	4.8	9.6	7.8	0.4	6	1	8	1	108060L	▲		▲	▲
L108.0006.12	1.2	3.2	4.8	9.6	7.8	0.6	6	1	8	1	108060L	▲		▲	▲
L108.0009.18	1.8	3.2	4.8	9.6	7.8	0.9	6	1	8	1	108060L			▲	▲

Dimensions in mm

P	●	●	●	●
M	●	●	●	-
K	●	●	●	●
N	-	o	-	o
S	-	o	-	-
H	-	-	-	-



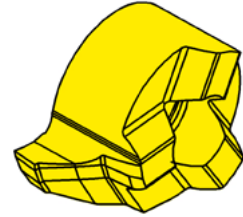
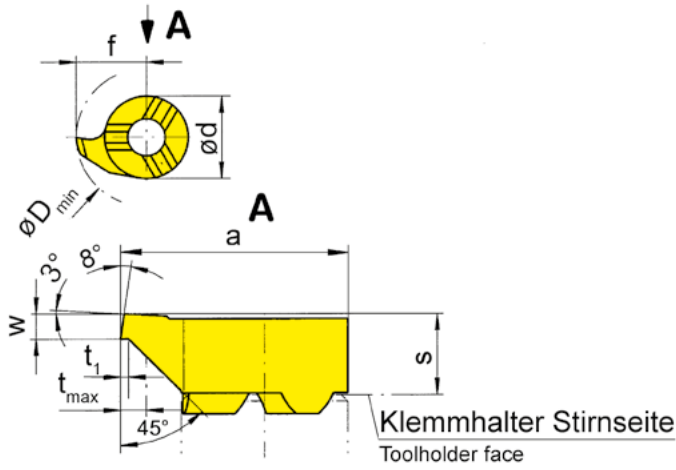
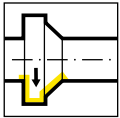

Coating grades

R = right hand version shown

L = left hand version

▲ In stock

Δ 2 weeks

F

Part number	w	s	f	a	d	t _{max}	t ₁	D _{min}	HIS	EG55	IG35	TI25	TN35
R108.0810.45	1	3.2	4.8	7.8	6	1.5	0.2	8	108060R	▲	▲	▲	▲
L108.0810.45	1	3.2	4.8	7.8	6	1.5	0.2	8	108060L	▲	▲	▲	▲

Dimensions in mm

P	●	●	●	●
M	●	●	●	-
K	●	●	-	●
N	-	○	●	○
S	-	○	-	-
H	-	-	-	-

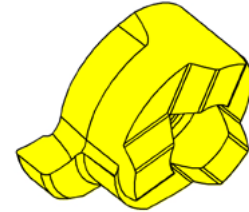
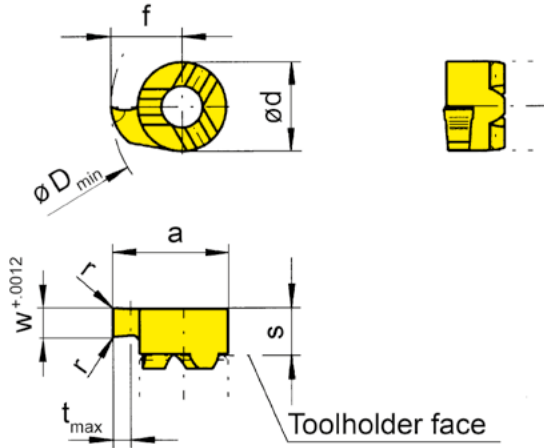
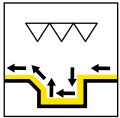

Coating grades

R = right hand version shown

L = left hand version

▲ In stock

Δ 2 weeks

Part number	w	s	f	a	r	d	t _{max}	D _{min}	HIS	MG12	IG35	TH35	TI25	TN35
RU108.0031.08	.031	.126	.189	.307	.008	.236	.039	.315	108060R	▲	▲	▲		▲
RU108.0046.08	.046	.126	.189	.307	.008	.236	.039	.315	108060R		▲	▲		▲
RU108.0062.08	.062	.126	.189	.307	.008	.236	.039	.315	108060R			▲	▲	▲
RU108.0078.08	.078	.126	.189	.307	.008	.236	.039	.315	108060R		▲	▲		▲
LU108.0046.08	.046	.126	.189	.307	.008	.236	.039	.315	108060L		▲			▲
LU108.0062.08	.062	.126	.189	.307	.008	.236	.039	.315	108060L					▲
LU108.0078.08	.078	.126	.189	.307	.008	.236	.039	.315	108060L		▲			▲

These inserts are optimized for finishing passes

Dimensions in inch



P	-	●	●	●	●
M	-	●	●	●	-
K	-	●	●	●	●
N	●	○	-	●	○
S	-	○	-	-	-
H	-	-	-	-	-



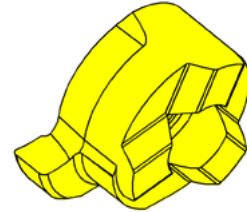
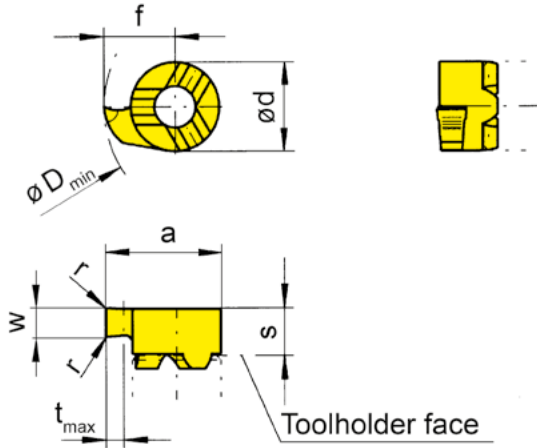
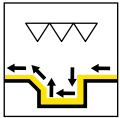

Coating grades

R = right hand version shown

L = left hand version

▲ In stock

Δ 2 weeks

F

Part number	w	s	f	a	r	d	t _{max}	D _{min}	HIS	EG55	IG35	TH35	TI25	TN35
R108.0150.02	1.5	3.2	4.8	7.8	0.2	6	1	8	108060R	▲	▲	▲	▲	▲
L108.0150.02	1.5	3.2	4.8	7.8	0.2	6	1	8	108060L	▲	▲	▲	▲	▲

These inserts are optimized for finishing passes

Dimensions in mm

P	●	●	●	●	●
M	●	●	●	●	-
K	●	●	●	-	●
N	-	○	-	●	○
S	-	○	-	-	-
H	-	-	-	-	-

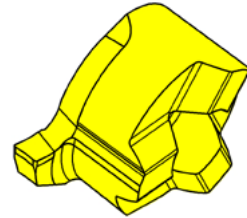
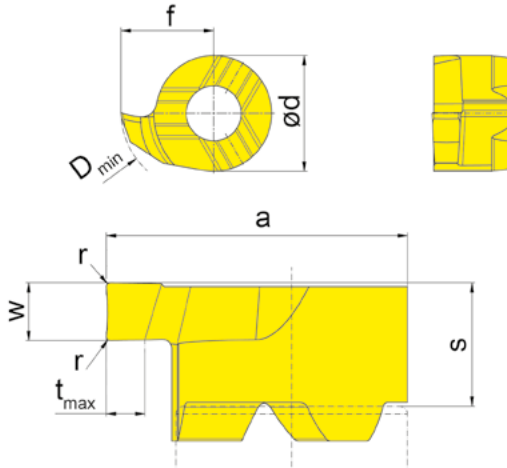
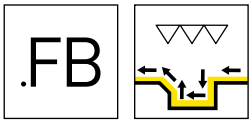

Coating grades

R = right hand version shown

L = left hand version

▲ In stock

Δ 2 weeks

Part number	w	s	f	a	r	d	t _{max}	D _{min}	HIS	EG35
R108.FB10.01	1	3.2	4.8	7.8	0.1	6	1	8	108060R	▲
R108.FB15.01	1.5	3.2	4.8	7.8	0.1	6	1	8	108060R	▲
L108.FB10.01	1	3.2	4.8	7.8	0.1	6	1	8	108060L	▲
L108.FB15.01	1.5	3.2	4.8	7.8	0.1	6	1	8	108060L	▲

These inserts feature an optimized geometry that produces a fine surface finish

Dimensions in mm

P	●
M	●
K	●
N	○
S	-
H	-

Smallest possible width of groove calculation, w_x

Example insert: R108.FB10.01

$$w_x = 2 \times \text{Width of insert (w)} - 2 \times \text{Insert corner radius (r)}$$

$$w_x = 2 \times 1 \text{ mm} - 2 \times 0.1 \text{ mm}$$

$$w_x = 1.8 \text{ mm}$$

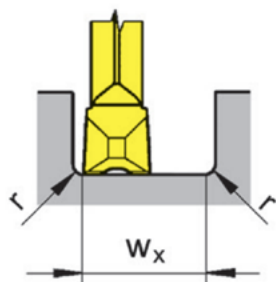

Operation order



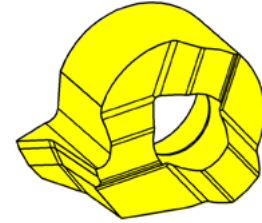
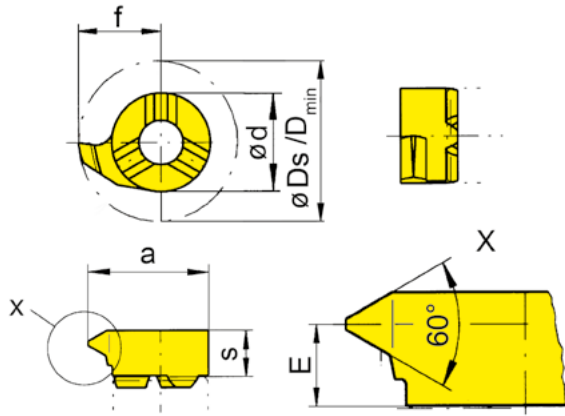
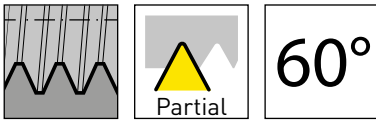

Coating grades

R = right hand version shown

L = left hand version

▲ In stock

Δ 2 weeks

F

Part number	P	TPI	TPI _{max}	E	f	a	d	s	D _{min}	Ds	HIS	Coating grades				
												EG55	IG35	TH35	TI25	TN35
R108.0205.01	0.5	28	64	2.8	4.8	7.8	6	3.6	8	9.6	108060R	▲	▲	▲	▲	▲
R108.0510.01	1	18	32	2.8	4.8	7.8	6	3.6	8	9.6	108060R	▲	▲	▲	▲	▲
R108.0815.01	1.5	12	20	2.6	4.8	7.8	6	3.6	8	9.6	108060R	▲	▲	▲	▲	▲
L108.0205.01	0.5	28	64	2.8	4.8	7.8	6	3.6	8	9.6	108060L	▲	▲	▲	▲	▲
L108.0510.01	1	18	32	2.8	4.8	7.8	6	3.6	8	9.6	108060L	▲	▲	▲	▲	▲
L108.0815.01	1.5	12	20	2.6	4.8	7.8	6	3.6	8	9.6	108060L	▲	▲	▲	▲	▲

Dimensions in mm

	P	M	K	N	S	H
EG55	●	●	●	●	●	●
IG35	●	●	●	●	●	●
TH35	●	●	●	●	●	●
TI25	●	●	●	●	●	●
TN35	●	●	●	●	●	●

Insert

S108 $\varnothing \geq 8$ mm

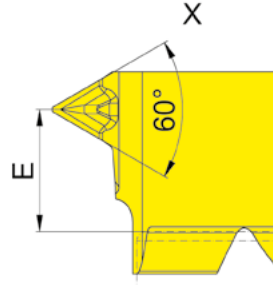
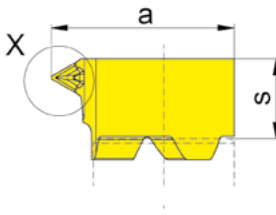
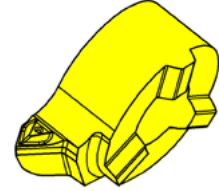
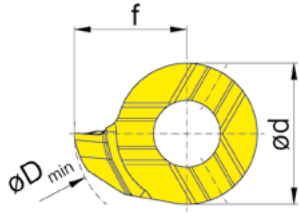

Coating grades

R = right hand version shown

L = left hand version

▲ In stock

Δ 2 weeks

Part number	P	TPI	TPI _{max}	E	f	a	d	s	D _{min}	HIS	EG55
RS108.0205.GM1	0.5	28	64	2.6	4.8	7.8	6	3.4	8	108060R	▲
RS108.0510.GM1	1	18	32	2.6	4.8	7.8	6	3.4	8	108060R	▲
RS108.0815.GM1	1.5	12	20	2.6	4.8	7.8	6	3.4	8	108060R	▲
LS108.0205.GM1	0.5	28	64	2.6	4.8	7.8	6	3.4	8	108060L	▲
LS108.0510.GM1	1	18	32	2.6	4.8	7.8	6	3.4	8	108060L	▲
LS108.0815.GM1	1.5	12	20	2.6	4.8	7.8	6	3.4	8	108060L	▲

Dimensions in mm

P	●
M	●
K	●
N	-
S	-
H	-



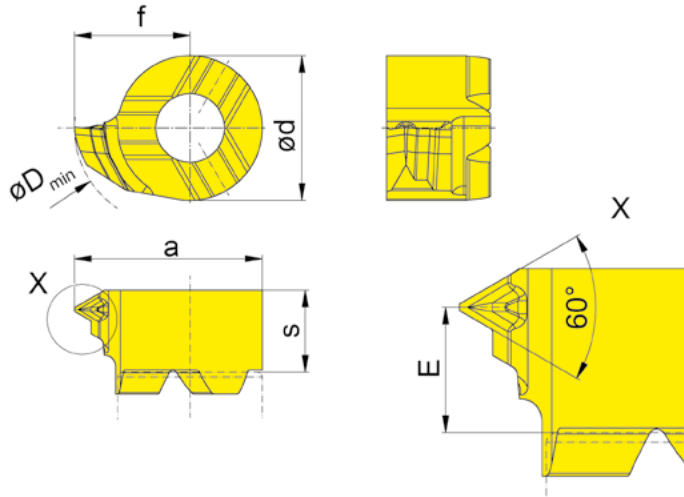

Coating grades

R = right hand version shown

L = left hand version

▲ In stock

Δ 2 weeks

F

Part number	P	E	f	a	d	s	D _{min}	HIS	EG55
RS108.0305.GM2	0.5	2.6	4.8	7.8	6	3.4	8	108060R	▲
RS108.0510.GM2	1	2.6	4.8	7.8	6	3.4	8	108060R	▲
RS108.0512.GM2	1.25	2.6	4.8	7.8	6	3.4	8	108060R	▲
RS108.0815.GM2	1.5	2.6	4.8	7.8	6	3.4	8	108060R	▲
LS108.0305.GM2	0.5	2.6	4.8	7.8	6	3.4	8	108060L	▲
LS108.0510.GM2	1	2.6	4.8	7.8	6	3.4	8	108060L	▲
LS108.0512.GM2	1.25	2.6	4.8	7.8	6	3.4	8	108060L	▲
LS108.0815.GM2	1.5	2.6	4.8	7.8	6	3.4	8	108060L	▲

Dimensions in mm

P	●
M	●
K	●
N	-
S	-
H	-

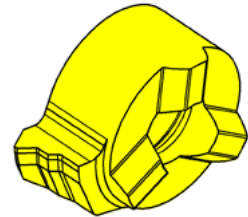
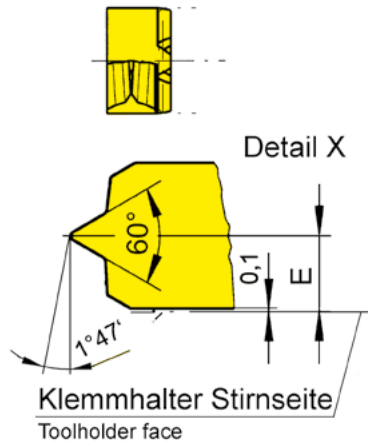
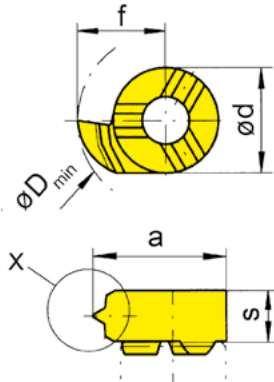

R = right hand version shown

L = left hand version

▲ In stock

Δ 2 weeks

Part number	TPI	E	f	d	s	D _{min}	HIS	Coating grades			
								EG55	IG35	TN35	
R108.NP14.02	14	1.9	4.8	6	3.6	8	108060R	▲	▲	▲	
R108.NP18.02	18	1.9	4.8	6	3.6	8	108060R	▲	▲	▲	
R108.NP27.02	27	1.9	4.8	6	3.6	8	108060R	Δ		▲	
NPT thread								P	●	●	●
Dimensions in mm								M	●	●	-
								K	●	●	●
								N	-	○	○
								S	-	○	-
								H	-	-	-



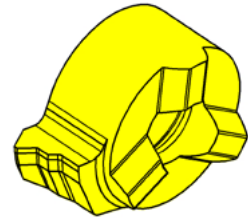
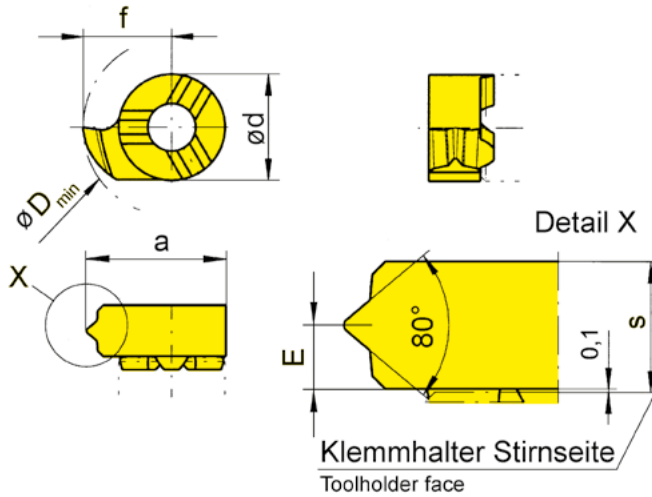

Coating grades

R = right hand version shown

L = left hand version

▲ In stock

Δ 2 weeks

Part number	TPI	E	f	d	s	D _{min}	HIS	EG55	TN35
R108.PG18.02	18	1.9	4.8	6	3.6	8	108060R	▲	▲
R108.PG20.02	20	1.9	4.8	6	3.6	8	108060R	▲	▲

Dimensions in mm

P	●	●
M	●	-
K	●	●
N	-	○
S	-	-
H	-	-

F







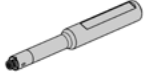
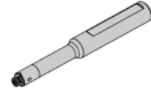

G

MINI 10P

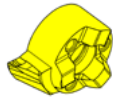
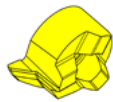
Bore Ø		Tool System											
mm	in	105	109	110	106	107	108	10P	111	11P	114	116	18P
≥ 0.2	≥ .0079	•											
≥ 0.5	≥ .0197	•											
≥ 0.7	≥ .0276	•											
≥ 1.0	≥ .0394	•											
≥ 1.5	≥ .0591	•											
≥ 2.0	≥ .0787	•											
≥ 3.0	≥ .1181	•											
≥ 4.0	≥ .1575	•											
≥ 5.0	≥ .1969	•											
≥ 6.0	≥ .2362	•	•	•	•								
≥ 6.8	≥ .2677		•	•	•								
≥ 7.0	≥ .2756		•			•							
≥ 7.8	≥ .3071			•		•	•						
≥ 8.0	≥ .3150			•		•	•						
≥ 9.0	≥ .3543			•		•	•	•					
≥ 10.0	≥ .3937			•				•	•	•			
≥ 10.5	≥ .4134									•			
≥ 11.0	≥ .4331								•	•			
≥ 11.5	≥ .4528									•			
≥ 13.8	≥ .5433										•		
≥ 14.0	≥ .5512										•	•	
≥ 16.0	≥ .6299									•		•	
≥ 16.5	≥ .6496										[•]		
≥ 18.0	≥ .7087												•
Depth of groove		2.5	2.5	4.0	0.8	2.0	1.0	3.0	2.3	3.5	4.0, (6.5)	4.3	8.0
		.0984	.0984	.1575	.0315	.0787	.0394	.1181	.0906	.1378	.1575, (.2559)	.1693	.3150
Width of groove		0.5-2.0	1.0-2.0	1.0-3.0	0.7-1.5	1.0-2.0	0.7-2.0	1.0-3.0	0.7-3.0	1.0-3.0	0.7-3.0	0.7-4.0	2.0-3.0
		.0197- .0787	.0394- .0787	.0394- .1181	.0276- .0591	.0394- .0787	.0276- .0787	.0394- .1181	.0276- .1181	.0394- .1181	.0276- .1181	.0276- .1575	.0787- .1181
Operations													
Grooving		•	•	•	•	•	•	•	•	•	•	•	•
Boring		•	•	•	•	•	•		•		•	•	
Threading		•	•			•	•		•		•	•	
Chamfering		•	•			•	•		•		•	•	
Face Grooving		•	•	•							•		
Boring and Profiling		•					•	•	•	•	•	•	

G

HOLDERS	Round Shank	
	 Page 285-286 Holder BU10P Inch Shank	 Page 287-288 Holder B10P

INSERTS	Boring			
	 Page 289 Bore Contouring .R Chipbreaker	 Page 290 Bore Contouring and Profiling	 Page 291 Back Boring	 Page 292 Chamfering, Profi- ling, Back Boring
	Grooving			
	 Page 293, 295 Grooving	 Page 294, 296 Grooving .D Chipbreaker	 Page 297 Grooving Full Radius	



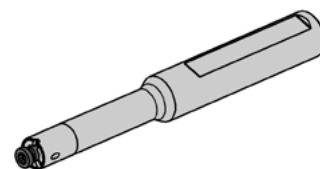
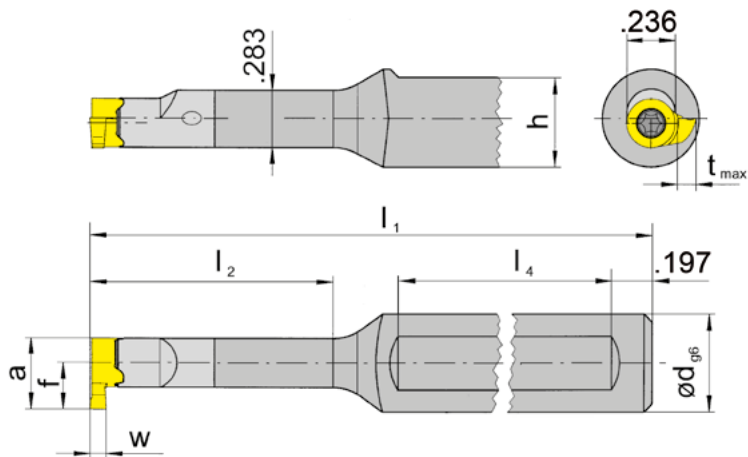
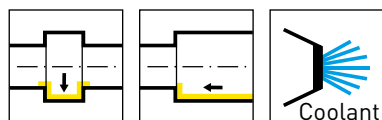

R = right hand version shown

L = left hand version

Part number	d	l ₁	l ₂	h	l ₄	HWS
RBU10P.0500.00	.500	2.756	.492	.461	1.575	10P060R
RBU10P.0500.01	.500	3.150	.827	.461	1.772	10P060R
RBU10P.0500.02	.500	3.543	1.181	.461	1.772	10P060R
RBU10P.0500.03	.500	3.937	1.654	.461	1.772	10P060R
LBU10P.0500.00	.500	2.756	.492	.461	1.575	10P060L
LBU10P.0500.01	.500	3.150	.827	.461	1.772	10P060L
LBU10P.0500.02	.500	3.543	1.181	.461	1.772	10P060L
LBU10P.0500.03	.500	3.937	1.654	.461	1.772	10P060L

For w, a, t_{max} and f dimensions, see insert pages

Dimensions in inch



Spare Parts

Toolholder	Clamping Screw	TORX PLUS® Wrench	Torque Value
R/LBU10P...	2.6.5T8EP	T8PL	1.2 Nm

G

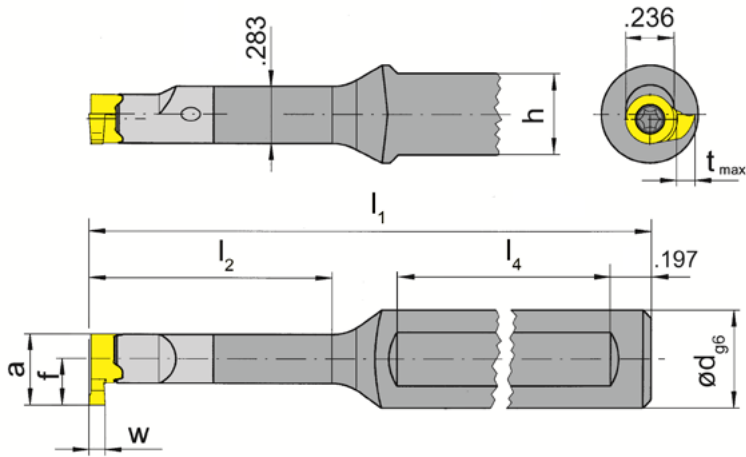
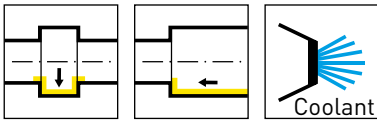

R = right hand version shown

L = left hand version

Part number	d	l ₁	l ₂	h	l ₄	HWS
RBU10P.0500.2.00	.500	2.756	.492	.461	1.575	10P060R
RBU10P.0500.2.01	.500	3.150	.827	.461	1.772	10P060R
RBU10P.0500.2.02	.500	3.543	1.181	.461	1.772	10P060R
RBU10P.0500.2.03	.500	3.937	1.654	.461	1.772	10P060R
LBU10P.0500.2.00	.500	2.756	.492	.461	1.575	10P060L
LBU10P.0500.2.01	.500	3.150	.827	.461	1.772	10P060L
LBU10P.0500.2.02	.500	3.543	1.181	.461	1.772	10P060L
LBU10P.0500.2.03	.500	3.937	1.654	.461	1.772	10P060L

For w, a, tmax and f dimensions, see insert pages

Dimensions in inch



Spare Parts

Toolholder	Clamping Screw	TORX PLUS® Wrench	Torque Value
R/LBU10P...	2.6.5T8EP	T8PL	1.2 Nm



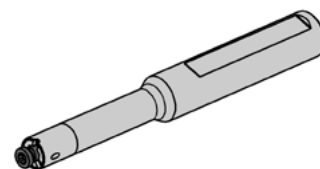
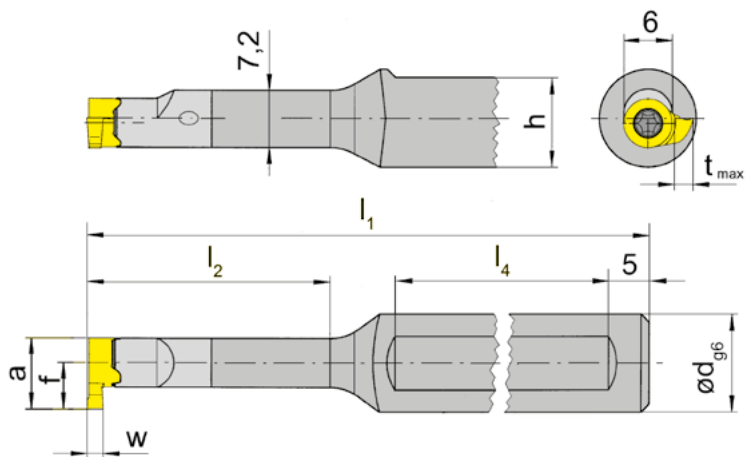
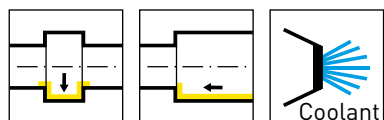

R = right hand version shown

L = left hand version

Part number	d	l ₁	l ₂	h	l ₄	HWS
RB10P.0012.00	12	70	12.5	11	40	10P060R
RB10P.0012.01	12	80	21	11	45	10P060R
RB10P.0012.02	12	90	30	11	45	10P060R
RB10P.0012.03	12	100	42	11	45	10P060R
LB10P.0012.00	12	70	12.5	11	40	10P060L
LB10P.0012.01	12	80	21	11	45	10P060L
LB10P.0012.02	12	90	30	11	45	10P060L
LB10P.0012.03	12	100	42	11	45	10P060L

For w, a, f, t_{max} and dimensions, see insert pages

Dimensions in mm

Spare Parts

Toolholder	Clamping Screw	TORX PLUS® Wrench	Torque Value
R/LB10P...	2.6.5T8EP	T8PL	1.2 Nm



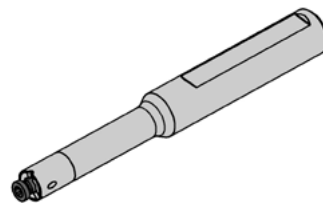
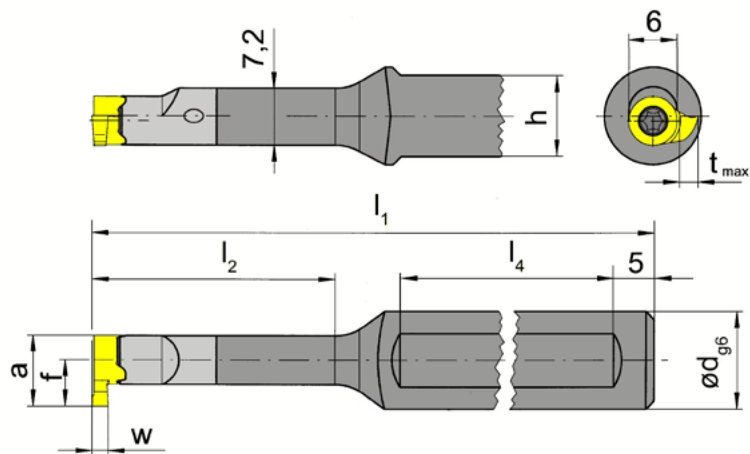
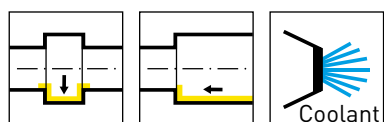

R = right hand version shown

L = left hand version

Part number	d	l ₁	l ₂	h	l ₄	HWS
RB10P.0012.2.00	12	70	12.5	11	40	10P060R
RB10P.0012.2.01	12	80	21	11	45	10P060R
RB10P.0012.2.02	12	90	30	11	45	10P060R
RB10P.0012.2.03	12	100	42	11	45	10P060R
LB10P.0012.2.00	12	70	12.5	11	40	10P060L
LB10P.0012.2.01	12	80	21	11	45	10P060L
LB10P.0012.2.02	12	90	30	11	45	10P060L
LB10P.0012.2.03	12	100	42	11	45	10P060L

For w, a, t_{max} and f dimensions, see insert pages

Dimensions in mm

Spare Parts

Toolholder	Clamping Screw	TORX PLUS® Wrench	Torque Value
R/LB10P...	2.6.5T8EP	T8PL	1.2 Nm



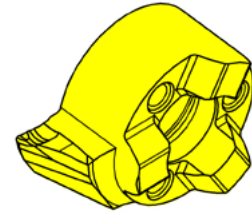
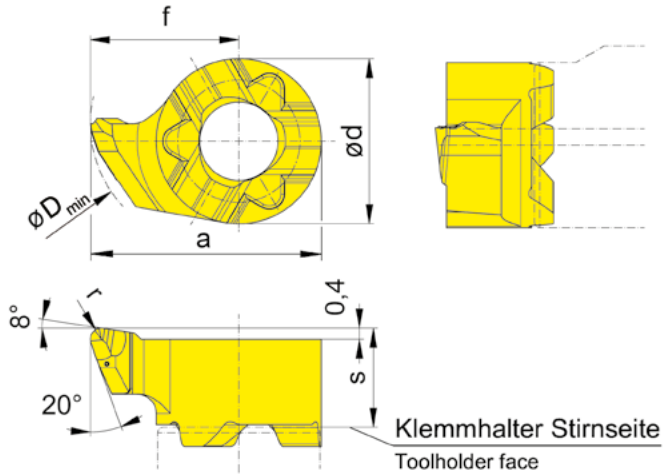
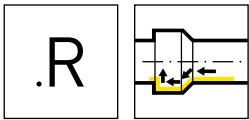

Coating grades

R = right hand version shown

L = left hand version

▲ In stock

△ 2 weeks

Part number	s	f	a	r	d	D _{min}	HIS	Coating grades	
								EG55	TH35
RS10P.1854.R2	3.6	5.4	8.4	0.2	6	8.8	10P060R	▲	▲
RS10P.1854.R4	3.6	5.4	8.4	0.4	6	8.8	10P060R	▲	▲
LS10P.1854.R2	3.6	5.4	8.4	0.2	6	8.8	10P060L	▲	▲
LS10P.1854.R4	3.6	5.4	8.4	0.4	6	8.8	10P060L	△	▲
								P	● ●
								M	● ●
								K	● ●
								N	- -
								S	- -
								H	- -

Dimensions in mm

G

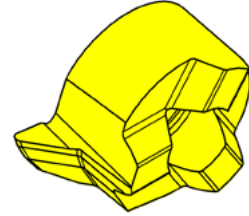
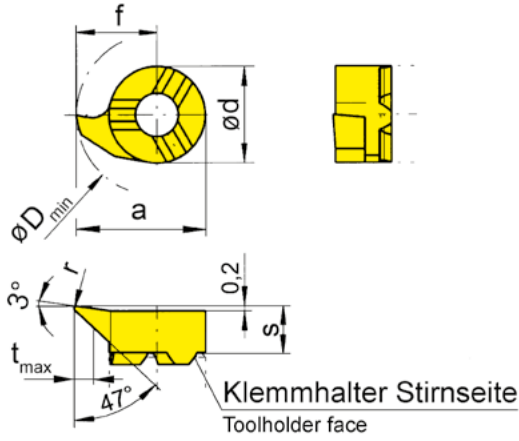
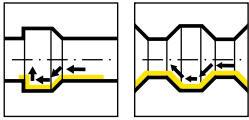

Coating grades

R = right hand version shown

L = left hand version

▲ In stock

Δ 2 weeks

Part number	s	f	a	r	d	t _{max}	D _{min}	HIS	EG55
R10P.4765.2.02	3.6	6.5	9.5	0.2	6	3	10	10P060R	▲
L10P.4765.2.02	3.6	6.5	9.5	0.2	6	3	10	10P060L	Δ
									P ●
									M ●
									K ●
									N -
									S -
									H -

Dimensions in mm



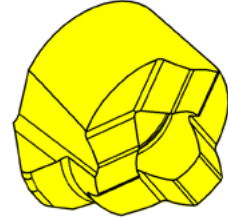
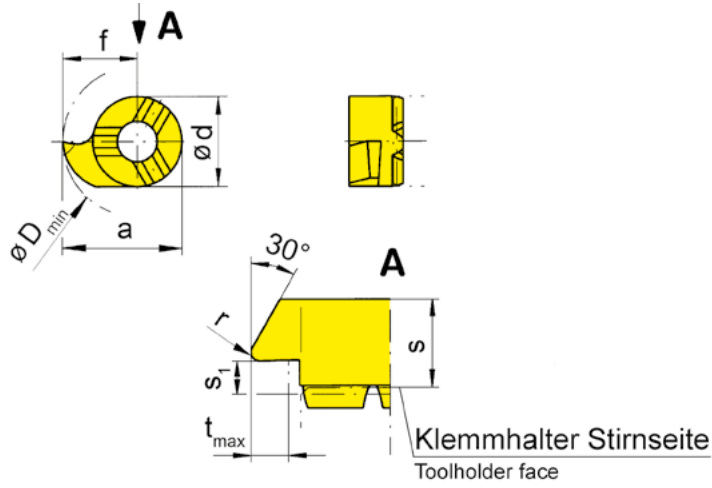
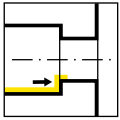

Coating grades

R = right hand version shown

L = left hand version

▲ In stock

Δ 2 weeks

Part number	s	f	a	r	s ₁	d	t _{max}	D _{min}	HIS	EG55
R10P.3065.2.02	3.75	6.5	9.5	0.2	1	6	3	10	10P060R	▲
L10P.3065.2.02	3.75	6.5	9.5	0.2	1	6	3	10	10P060L	Δ
										P ●
										M ●
										K ●
										N -
										S -
										H -

Dimensions in mm

G

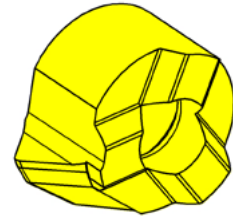
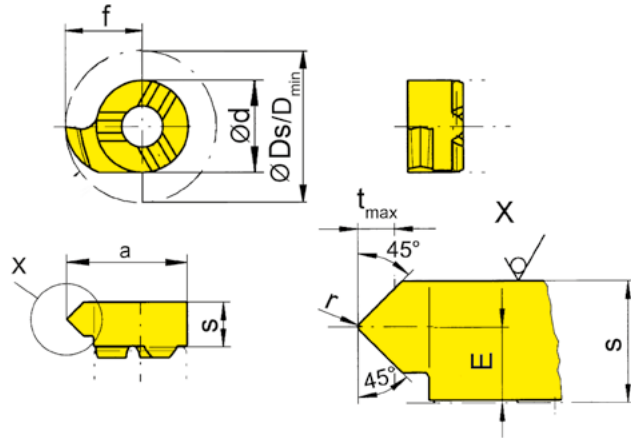
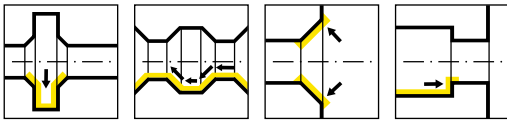

Coating grades

R = right hand version shown

L = left hand version

▲ In stock

Δ 2 weeks

Part number	E	f	r	d	s	a	D_{min}	α	t_{max}	HIS	EG55
R10P.4545.1.02	1.9	5.5	0.2	6	3.75	8.5	9	45°	1.5	10P060R	▲
L10P.4545.1.02	1.9	5.5	0.2	6	3.75	8.5	9	45°	1.5	10P060L	▲

Dimensions in mm

P	●
M	●
K	●
N	-
S	-
H	-



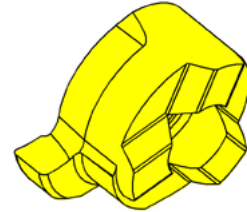
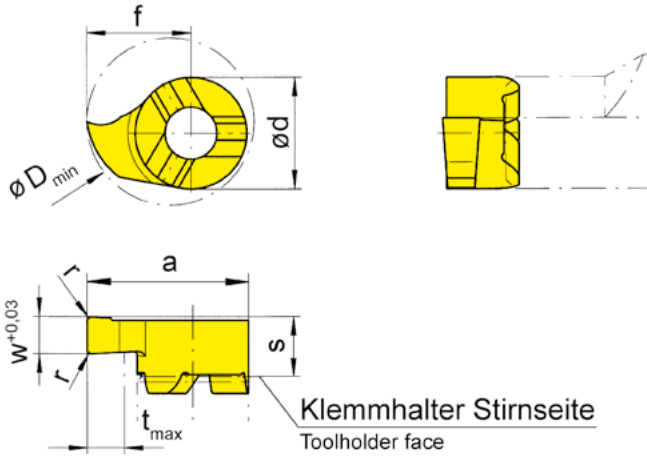
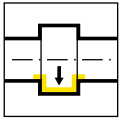

Coating grades

R = right hand version shown

L = left hand version

▲ In stock

Δ 2 weeks

Part number	w	s	f	a	r	d	t _{max}	D _{min}	HIS	Coating grades		
										EG55	IG35	TH35
R10P.0100.1.00	1	3.6	5.5	8.5	-	6	2	9	10P060R	▲	▲	▲
R10P.0150.1.00	1.5	3.6	5.5	8.5	-	6	2	9	10P060R	▲	▲	▲
R10P.0200.1.02	2	3.6	5.5	8.5	0.2	6	2	9	10P060R	▲	▲	▲
R10P.0250.1.02	2.5	3.6	5.5	8.5	0.2	6	2	9	10P060R	▲		▲
R10P.0300.1.02	3	3.6	5.5	8.5	0.2	6	2	9	10P060R	▲		▲
L10P.0100.1.00	1	3.6	5.5	8.5	-	6	2	9	10P060L	▲		▲
L10P.0150.1.00	1.5	3.6	5.5	8.5	-	6	2	9	10P060L	Δ		▲
L10P.0200.1.02	2	3.6	5.5	8.5	0.2	6	2	9	10P060L	▲		▲
L10P.0250.1.02	2.5	3.6	5.5	8.5	0.2	6	2	9	10P060L	Δ		▲
L10P.0300.1.02	3	3.6	5.5	8.5	0.2	6	2	9	10P060L	Δ		▲

Inserts ending in ".00" have a .002" x 45° (0.05mm) corner chamfer. Inserts ending in ".02" feature the corner radius listed in the table

Dimensions in mm

	P	M	K	N	S	H
EG55	●	●	●	-	-	-
IG35	●	●	●	○	○	-
TH35	●	●	●	-	-	-

G

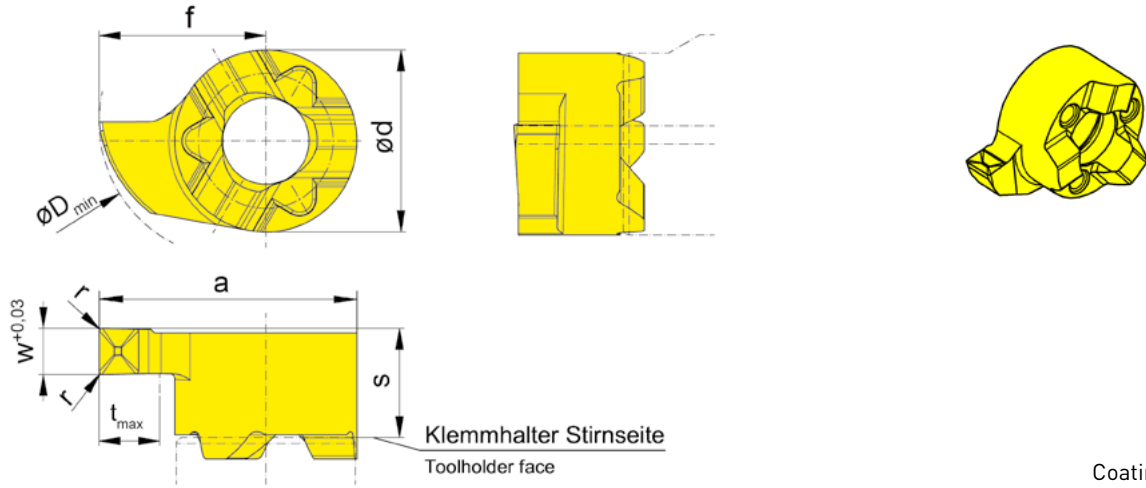
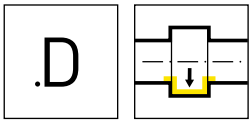

R = right hand version shown

L = left hand version

▲ In stock

Δ 2 weeks

Coating grades

Part number	w	s	f	a	r	d	t _{max}	D _{min}	HIS	EG55	TH35
RS10P.0100.1.D1	1	3.6	5.5	8.5	0.1	6	2	9	10P060R	▲	▲
RS10P.0150.1.D1	1.5	3.6	5.5	8.5	0.1	6	2	9	10P060R	▲	▲
RS10P.0200.1.D2	2	3.6	5.5	8.5	0.2	6	2	9	10P060R	▲	▲
LS10P.0100.1.D1	1	3.6	5.5	8.5	0.1	6	2	9	10P060L	Δ	▲
LS10P.0150.1.D1	1.5	3.6	5.5	8.5	0.1	6	2	9	10P060L	Δ	▲
LS10P.0200.1.D2	2	3.6	5.5	8.5	0.2	6	2	9	10P060L	Δ	▲
										P	● ●
										M	● ●
										K	● ●
										N	- -
										S	- -
										H	- -

Dimensions in mm



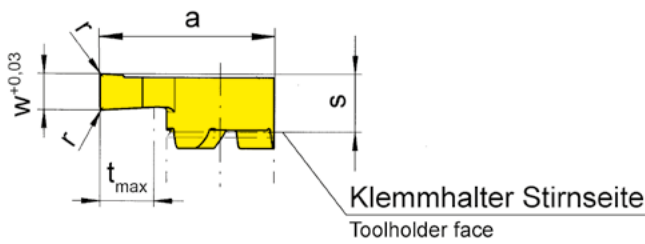
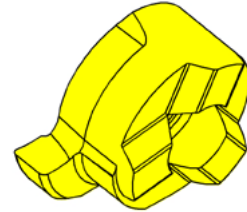
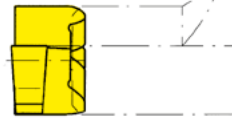
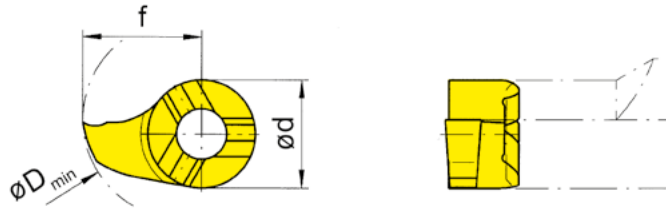
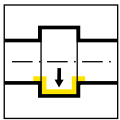

R = right hand version shown

L = left hand version

▲ In stock

Δ 2 weeks

Coating grades

Part number	w	s	f	a	r	d	t _{max}	D _{min}	HIS	Coating grades		
										EG55	IG35	TH35
R10P.0100.2.00	1	3.6	6.5	9.5	-	6	3	10	10P060R	▲		▲
R10P.0150.2.00	1.5	3.6	6.5	9.5	-	6	3	10	10P060R	▲	▲	▲
R10P.0200.2.02	2	3.6	6.5	9.5	0.2	6	3	10	10P060R	▲		▲
L10P.0100.2.00	1	3.6	6.5	9.5	-	6	3	10	10P060L	Δ		▲
L10P.0150.2.00	1.5	3.6	6.5	9.5	-	6	3	10	10P060L			▲
L10P.0200.2.02	2	3.6	6.5	9.5	0.2	6	3	10	10P060L	▲		▲

Inserts ending in ".00" have a .002" x 45° (0.05mm) corner chamfer. Inserts ending in ".02" feature the corner radius listed in the table

Dimensions in mm

	EG55	IG35	TH35
P	●	●	●
M	●	●	●
K	●	●	●
N	-	o	-
S	-	o	-
H	-	-	-

G

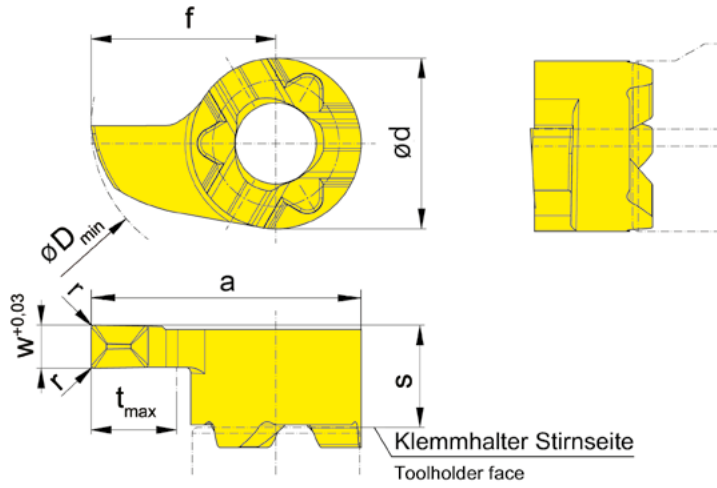
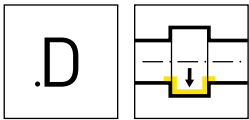

Coating grades

R = right hand version shown

L = left hand version

▲ In stock

△ 2 weeks

Part number	w	s	f	a	r	d	t _{max}	D _{min}	HIS	EG55	TH35
RS10P.0150.2.D1	1.5	3.6	6.5	9.5	0.1	6	3	10	10P060R	▲	▲
RS10P.0200.2.D2	2	3.6	6.5	9.5	0.2	6	3	10	10P060R	▲	▲
LS10P.0150.2.D1	1.5	3.6	6.5	9.5	0.1	6	3	10	10P060L	△	▲
LS10P.0200.2.D2	2	3.6	6.5	9.5	0.2	6	3	10	10P060L	▲	▲

P	●	●
M	●	●
K	●	●
N	-	-
S	-	-
H	-	-

Dimensions in mm



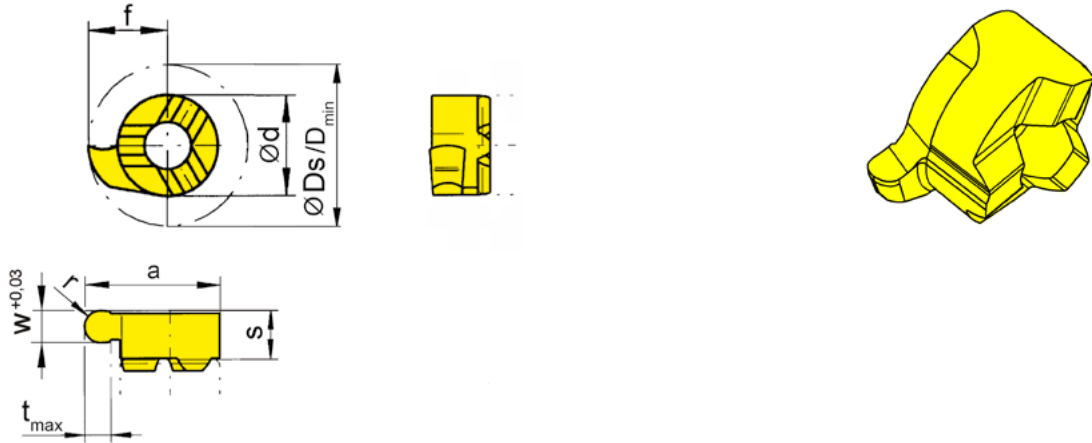
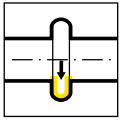

Coating grades

R = right hand version shown

L = left hand version

▲ In stock

Δ 2 weeks

Part number	w	s	f	a	r	d	t _{max}	D _{min}	HIS	EG55
R10P.0005.2.10	1	3.6	6.5	9.5	0.5	6	3	10	10P060R	▲
R10P.0007.2.15	1.5	3.6	6.5	9.5	0.76	6	3	10	10P060R	▲
R10P.0009.2.18	1.8	3.6	6.5	9.5	0.9	6	3	10	10P060R	Δ
L10P.0005.2.10	1	3.6	6.5	9.5	0.5	6	3	10	10P060L	Δ
L10P.0007.2.15	1.5	3.6	6.5	9.5	0.76	6	3	10	10P060L	Δ
L10P.0009.2.18	1.8	3.6	6.5	9.5	0.9	6	3	10	10P060L	▲

Dimensions in mm

P	●
M	●
K	●
N	-
S	-
H	-



H

MINI 111

Bore Ø		Tool System											
mm	in	105	109	110	106	107	108	10P	111	11P	114	116	18P
≥ 0.2	≥ .0079	•											
≥ 0.5	≥ .0197	•											
≥ 0.7	≥ .0276	•											
≥ 1.0	≥ .0394	•											
≥ 1.5	≥ .0591	•											
≥ 2.0	≥ .0787	•											
≥ 3.0	≥ .1181	•											
≥ 4.0	≥ .1575	•											
≥ 5.0	≥ .1969	•											
≥ 6.0	≥ .2362	•	•	•	•								
≥ 6.8	≥ .2677		•	•	•								
≥ 7.0	≥ .2756		•			•							
≥ 7.8	≥ .3071			•		•	•						
≥ 8.0	≥ .3150			•		•	•						
≥ 9.0	≥ .3543			•		•	•	•					
≥ 10.0	≥ .3937			•				•	•	•			
≥ 10.5	≥ .4134									•			
≥ 11.0	≥ .4331								•	•			
≥ 11.5	≥ .4528									•			
≥ 13.8	≥ .5433										•		
≥ 14.0	≥ .5512										•	•	
≥ 16.0	≥ .6299									•		•	
≥ 16.5	≥ .6496										(•)		
≥ 18.0	≥ .7087												•
Depth of groove		2.5	2.5	4.0	0.8	2.0	1.0	3.0	2.3	3.5	4.0, (6.5)	4.3	8.0
		.0984	.0984	.1575	.0315	.0787	.0394	.1181	.0906	.1378	.1575, (.2559)	.1693	.3150
Width of groove		0.5-2.0	1.0-2.0	1.0-3.0	0.7-1.5	1.0-2.0	0.7-2.0	1.0-3.0	0.7-3.0	1.0-3.0	0.7-3.0	0.7-4.0	2.0-3.0
		.0197- .0787	.0394- .0787	.0394- .1181	.0276- .0591	.0394- .0787	.0276- .0787	.0394- .1181	.0276- .1181	.0394- .1181	.0276- .1181	.0276- .1575	.0787- .1181
Operations													
Grooving		•	•	•	•	•	•	•	•	•	•	•	•
Boring		•	•	•	•	•	•		•		•	•	
Threading		•	•			•	•		•		•	•	
Chamfering		•	•			•	•		•		•	•	
Face Grooving		•	•	•							•		
Boring and Profiling		•					•	•	•	•	•	•	

H

HOLDERS

Round Shank

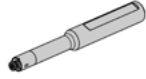

Page 302
Holder BU111
Inch Shank

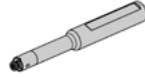

Page 303-304
Holder B111

INSERTS

Boring

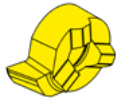

Page 305
Bore Contouring

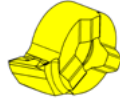

Page 306
Boring
.I Chipbreaker



Page 306
Bore Contouring
.R Chipbreaker



Page 308-309
Bore Contouring
and Profiling



Page 310
Back Boring



Page 311
Chamfering, Profi-
ling, Back Boring

Grooving



Page 312
Grooving
Inch



Page 313-315
Grooving



Page 316
Grooving
.D Chipbreaker

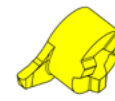

Page 317-318
Grooving
Full Radius





Page 319
Pre-Part Off

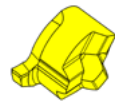

Page 320-321
Fine Finishing

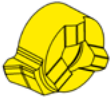
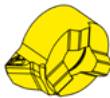
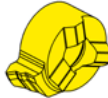
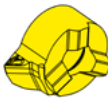

Page 322
Fine Finishing
.FB Geometry

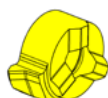
		Threading			
INSERTS					
	Page 323 Threading, 60° Partial Profile	Page 324 Threading, 60° .GM Chipbreaker, Partial	Page 325 Threading, 60° Full Profile	Page 326 Threading, 60° .GM Chipbreaker, Full	
					
	Page 327 Threading ACME	Page 328 Threading Trapezoidal	Page 329 Threading Whitworth		
	Cutting Data and Technical Instructions - Chapter M / Page 436				

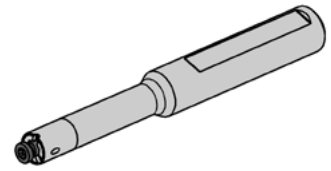
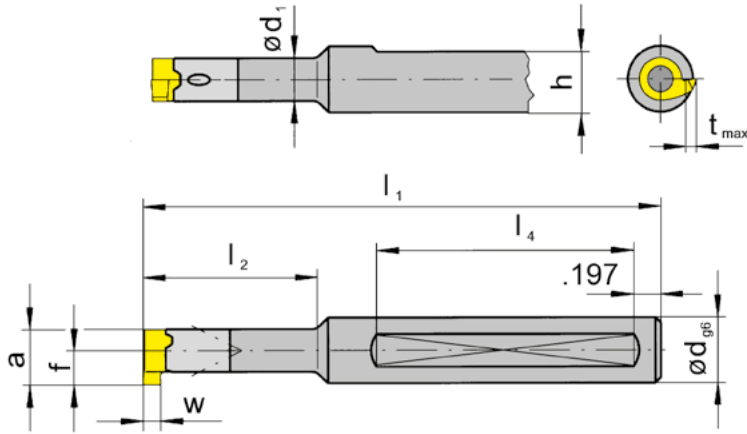
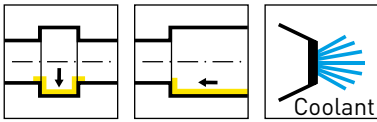

Picture = right hand insert shown

Part number	d	l_1	l_2	h	l_4	d_1	HWS
BU111.ST05.00	.500	2.953	.650	.460	1.575	.315	111080R • 111080L
BU111.0500.01	.500	3.740	1.142	.461	1.969	.315	111080R • 111080L
BU111.0500.02	.500	4.331	1.654	.461	1.969	.315	111080R • 111080L
BU111.0500.03	.500	4.724	2.205	.461	1.969	.315	111080R • 111080L

Holders with ".ST" are steel shanks

For w, a, t_{max} and f dimensions, see insert pages

Dimensions in inch



Spare Parts

Toolholder	Clamping Screw	TORX PLUS® Wrench	Torque Value
BU111...	3.5.12T10EP	T10PL	3 Nm

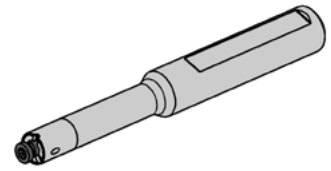
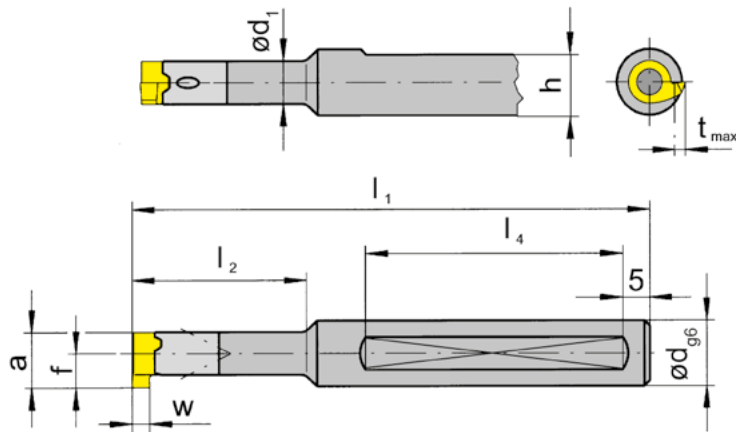
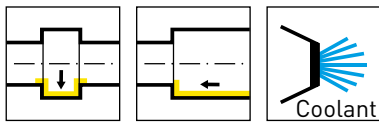

Picture = right hand cutting version

Part number	d	l ₁	l ₂	h	l ₄	d ₁	HWS
B111.0008.01A	8	80	-	-	-	-	111080R • 111080L
B111.0008.01	8	80	-	7	55	8	111080R • 111080L
B111.0012.00	12	75	16.5	11	40	8	111080R • 111080L
B111.0012.01	12	95	29	11	50	8	111080R • 111080L
B111.0012.02	12	110	42	11	50	8	111080R • 111080L
B111.0012.03	12	120	56	11	50	8	111080R • 111080L

For w, a, tmax and f dimensions, see insert pages

Dimensions in mm

1 clamping flat



Spare Parts

Toolholder	Clamping Screw	TORX PLUS® Wrench	Torque Value
B111...	3.5.12T10EP	T10PL	3 Nm

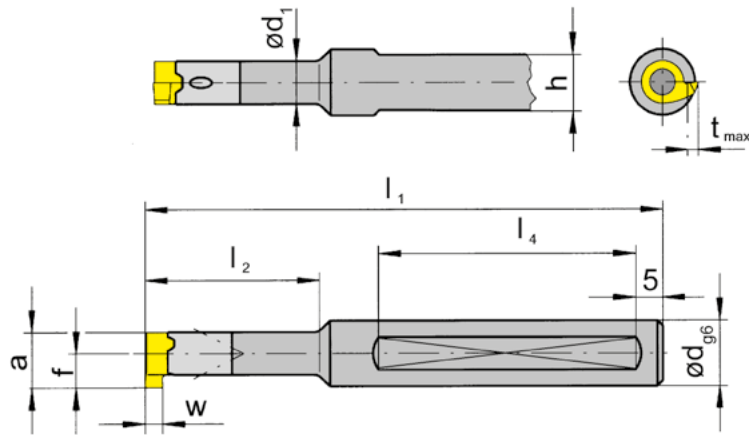
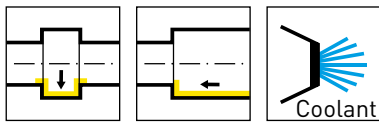

R = right hand version shown

Part number	d	l_1	l_2	h	l_4	d_1	HWS
B111.0012.2.00	12	75	16.5	11	40	8	111080R • 111080L
B111.0012.2.01	12	95	29	11	50	8	111080R • 111080L
B111.0012.2.02	12	110	42	11	50	8	111080R • 111080L
B111.0012.2.03	12	120	56	11	50	8	111080R • 111080L

For w, a, t_{max} and f dimensions, see insert pages

Dimensions in mm

2 clamping flats



Spare Parts

Toolholder	Clamping Screw	TORX PLUS® Wrench	Torque Value
B111...	3.5.12T10EP	T10PL	3 Nm

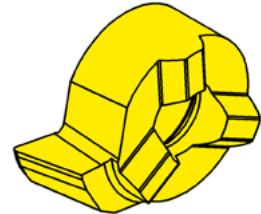
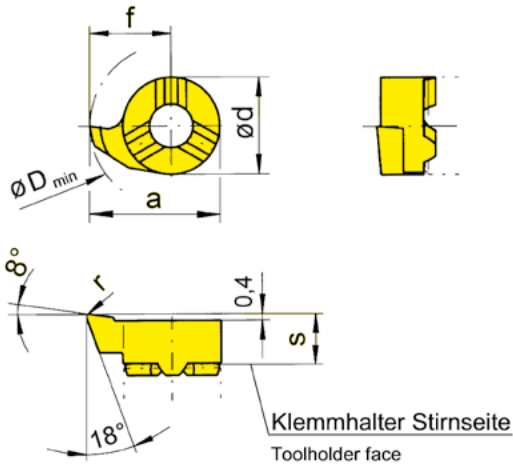
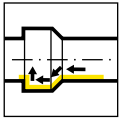

Coating grades

R = right hand version shown

L = left hand version

▲ In stock

Δ 2 weeks

Part number	s	f	a	r	d	D _{min}	HIS	EG55	IG35	TH35	TI25	TN35
R111.1855.02	3.95	5.5	9.5	0.2	8	9.8	111080R	▲	▲	▲	▲	▲
R111.1867.02	3.95	6.7	10.7	0.2	8	11	111080R	▲	▲	▲	▲	▲
L111.1855.02	3.95	5.5	9.5	0.2	8	9.8	111080L	▲	▲	▲	▲	▲
L111.1867.02	3.95	6.7	10.7	0.2	8	11	111080L	▲	▲	▲	▲	▲

Dimensions in mm

P	●	●	●	●	●
M	●	●	●	●	-
K	●	●	●	-	●
N	-	○	-	●	○
S	-	○	-	-	-
H	-	-	-	-	-

Insert

S111 $\varnothing \geq 11$ mm

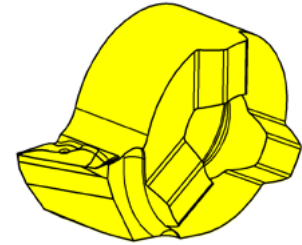
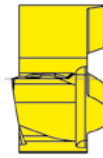
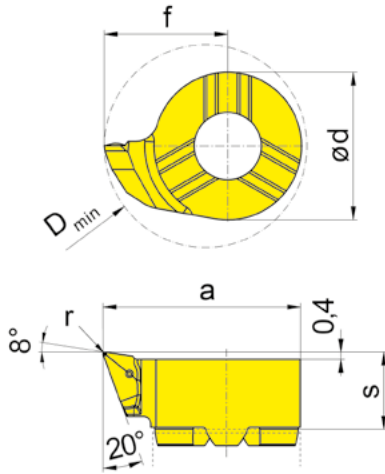
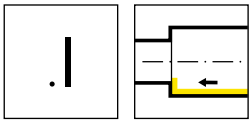

Coating grades

R = right hand version shown

▲ In stock

Δ 2 weeks

Part number	s	f	a	r	d	D _{min}	HIS	Coating grades	
								IG35	TH35
RS111.0820.105	4.2	6.7	10.7	0.05	8	11	111080R	Δ	Δ
RS111.0820.110	4.2	6.7	10.7	0.1	8	11	111080R	▲	▲
RS111.0820.120	4.2	6.7	10.7	0.2	8	11	111080R	▲	▲
								P	● ●
								M	● ●
								K	● ●
								N	○ -
								S	○ -
								H	- -

Dimensions in mm



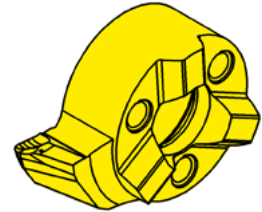
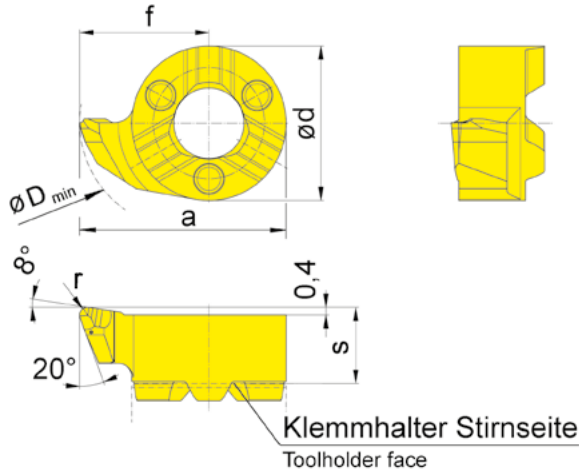
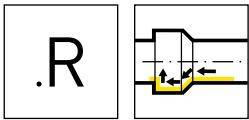

Coating grades

R = right hand version shown

L = left hand version

▲ In stock

Δ 2 weeks

Part number	s	f	a	r	d	D _{min}	HIS	EG55	TH35
RS111.1867.R2	3.95	6.7	10.7	0.2	8	11	111080R	▲	▲
RS111.1867.R4	3.95	6.7	10.7	0.4	8	11	111080R	▲	▲
LS111.1867.R2	3.95	6.7	10.7	0.2	8	11	111080L	▲	▲
LS111.1867.R4	3.95	6.7	10.7	0.4	8	11	111080L	▲	▲

Dimensions in mm

P	●	●
M	●	●
K	●	●
N	-	-
S	-	-
H	-	-

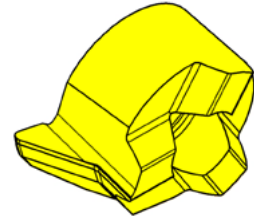
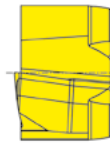
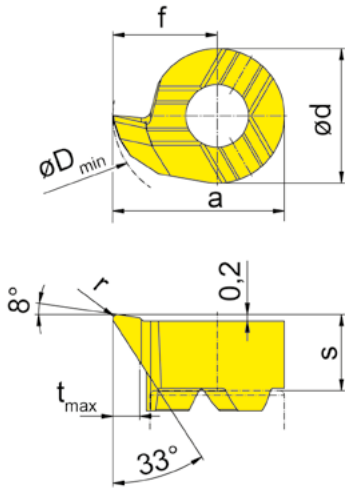
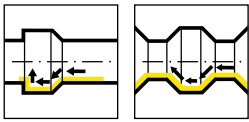

Coating grades

R = right hand version shown

L = left hand version

▲ In stock

Δ 2 weeks

Part number	s	f	a	r	d	t _{max}	D _{min}	HIS	EG55
R111.3367.02	3.95	6.7	10.7	0.2	8	1.8	11	111080R	▲
R111.3367.04	3.95	6.7	10.7	0.4	8	1.8	11	111080R	▲
L111.3367.02	3.95	6.7	10.7	0.2	8	1.8	11	111080L	
L111.3367.04	3.95	6.7	10.7	0.4	8	1.8	11	111080L	

Dimensions in mm

P	●
M	●
K	●
N	-
S	-
H	-



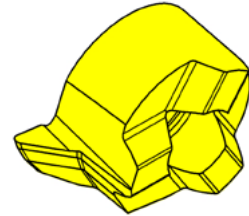
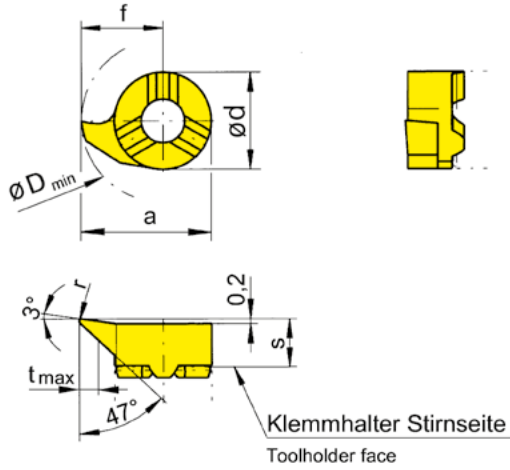
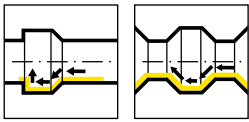

Coating grades

R = right hand version shown

L = left hand version

▲ In stock

Δ 2 weeks

Part number	s	f	a	r	d	t _{max}	D _{min}	HIS	EG55	IG35	TH35	TI25	TN35
R111.4767.02	3.95	6.7	10.7	0.2	8	2.3	11	111080R	▲	▲	▲	▲	▲
R111.4767.04	3.95	6.7	10.7	0.4	8	2.3	11	111080R	▲	▲	▲	▲	▲
L111.4767.02	3.95	6.7	10.7	0.2	8	2.3	11	111080L	▲	▲	▲	▲	▲
L111.4767.04	3.95	6.7	10.7	0.4	8	2.3	11	111080L	▲	▲	▲	Δ	▲

Dimensions in mm

P	●	●	●	●	●
M	●	●	●	●	-
K	●	●	●	-	●
N	-	○	-	●	○
S	-	○	-	-	-
H	-	-	-	-	-

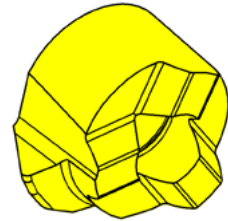
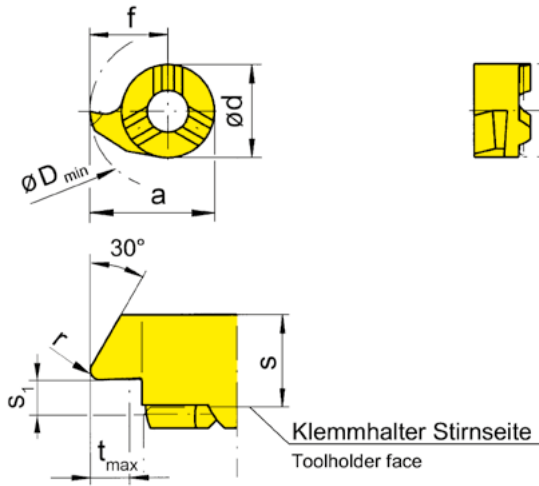
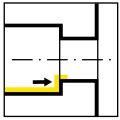

Coating grades

R = right hand version shown

L = left hand version

▲ In stock

Δ 2 weeks

Part number	s	f	a	r	s ₁	d	t _{max}	D _{min}	HIS	EG55	IG35	TH35	TN35
R111.3067.02	4.15	6.7	10.7	0.2	1.4	8	2.3	11	111080R	▲	▲	▲	▲
R111.3067.04	4.15	6.7	10.7	0.4	1.4	8	2.3	11	111080R	Δ	▲	▲	▲
L111.3067.02	4.15	6.7	10.7	0.2	1.4	8	2.3	11	111080L	▲	▲	▲	▲
L111.3067.04	4.15	6.7	10.7	0.4	1.4	8	2.3	11	111080L	▲	▲	▲	▲

Dimensions in mm

P	●	●	●	●
M	●	●	●	-
K	●	●	●	●
N	-	○	-	○
S	-	○	-	-
H	-	-	-	-



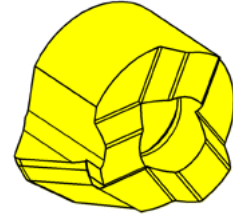
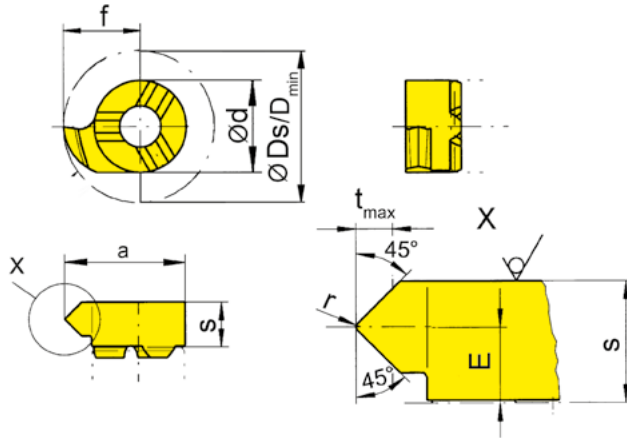
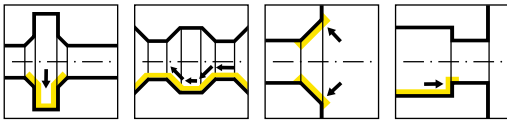

Coating grades

R = right hand version shown

L = left hand version

▲ In stock

Δ 2 weeks

Part number	E	f	D _s	r	d	s	a	t _{max}	D _{min}	Z	HIS	EG55	IG35	TN35
R111.4545.02	2.4	6.7	13.4	0.2	8	4.15	10.7	1.5	11	1	111080R	▲	▲	▲
L111.4545.02	2.4	6.7	13.4	0.2	8	4.15	10.7	1.5	11	1	111080L	▲	▲	▲

Dimensions in mm

P	●	●	●
M	●	●	-
K	●	●	●
N	-	○	○
S	-	○	-
H	-	-	-

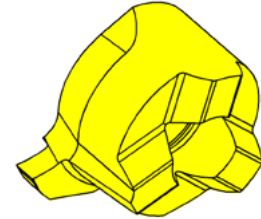
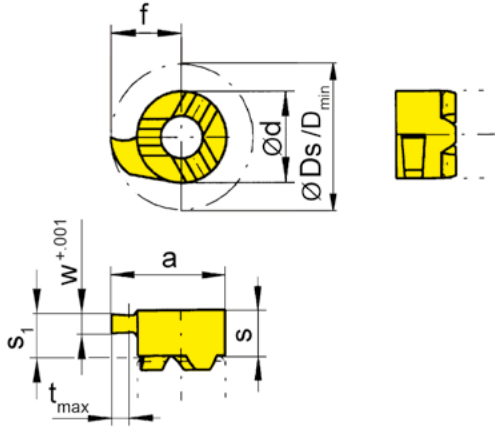
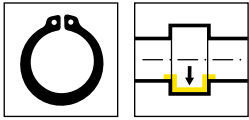

Coating grades

R = right hand version shown

L = left hand version

▲ In stock

△ 2 weeks

Part number	w	f	Ds	d	s	s ₁	a	t _{max}	D _{min}	HIS	Coating grades					
											MG12	IG35	TF45	TH35	TI25	TN35
RU111.0031.00	.031	.264	.528	.315	.163	.156	.421	.047	.433	111080R						
RU111.0039.00	.039	.264	.528	.315	.163	.156	.421	.059	.433	111080R	▲	▲		▲		▲
RU111.0046.00	.046	.264	.528	.315	.156	-	.421	.091	.433	111080R	▲	▲		▲	△	▲
RU111.0056.00	.056	.264	.528	.315	.156	-	.421	.091	.433	111080R	▲	▲		▲		▲
RU111.0062.00	.062	.264	.528	.315	.156	-	.421	.091	.433	111080R	▲	▲	▲	▲	△	▲
RU111.0078.00	.078	.264	.528	.315	.156	-	.421	.091	.433	111080R		▲		▲		▲
RU111.0094.00	.094	.264	.528	.315	.156	-	.421	.091	.433	111080R	△	▲		▲		▲
RU111.0125.00	.125	.264	.528	.315	.156	-	.421	.091	.433	111080R		▲		▲		▲
LU111.0031.00	.031	.264	.528	.315	.163	.156	.421	.047	.433	111080L		▲				▲
LU111.0039.00	.039	.264	.528	.315	.163	.156	.421	.059	.433	111080L		▲				▲
LU111.0046.00	.046	.264	.528	.315	.156	-	.421	.091	.433	111080L		▲				▲
LU111.0056.00	.056	.264	.528	.315	.156	-	.421	.091	.433	111080L		▲				▲
LU111.0062.00	.062	.264	.528	.315	.156	-	.421	.091	.433	111080L		▲				▲
LU111.0078.00	.078	.264	.528	.315	.156	-	.421	.091	.433	111080L		▲				▲
LU111.0094.00	.094	.264	.528	.315	.156	-	.421	.091	.433	111080L		▲				▲
LU111.0125.00	.125	.264	.528	.315	.156	-	.421	.091	.433	111080L		▲				▲
P	-	●	-	●	●	●	●	●	●							
M	-	●	-	●	●	●	●	●	●							
K	-	●	-	●	●	●	●	●	●							
N	●	○	-	●	●	●	●	●	●							
S	-	○	-	●	●	●	●	●	●							
H	-	-	-	-	-	-	-	-	-							

.031 and .039 widths are not face cutting and have limited depths of cut

Dimensions in inch



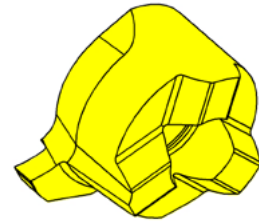
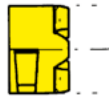
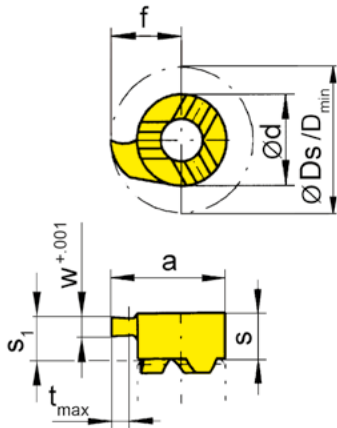
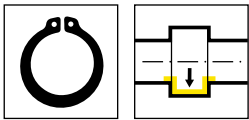

Coating grades

R = right hand version shown

L = left hand version

▲ In stock

Δ 2 weeks

Part number	w	f	Ds	d	s	s ₁	a	t _{max}	D _{min}	HIS	Coating grades				
											EG55	TH35	TN35		
R111.0070.00	0.74	6.7	13.4	8	4.15	3.95	10.7	1.2	11	111080R	▲	▲	▲		
R111.0080.00	0.84	6.7	13.4	8	4.15	3.95	10.7	1.3	11	111080R	▲	▲	▲		
R111.0090.00	0.94	6.7	13.4	8	4.15	3.95	10.7	1.5	11	111080R	▲	▲	▲		
L111.0070.00	0.74	6.7	13.4	8	4.15	3.95	10.7	1.2	11	111080L		▲	▲		
L111.0080.00	0.84	6.7	13.4	8	4.15	3.95	10.7	1.3	11	111080L		Δ	▲		
L111.0090.00	0.94	6.7	13.4	8	4.15	3.95	10.7	1.5	11	111080L		▲	▲		
Not face cutting, limited depth of cut												P	●	●	●
Dimensions in mm												M	●	●	-
												K	●	●	●
												N	-	-	o
												S	-	-	-
												H	-	-	-

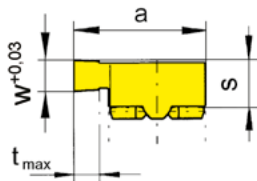
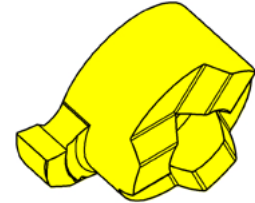
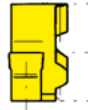
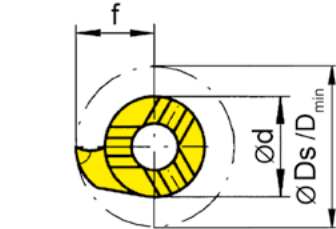
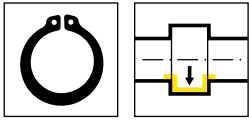

Coating grades

R = right hand version shown

L = left hand version

▲ In stock

Δ 2 weeks

Part number	w	s	f	Ds	d	a	t _{max}	D _{min}	HIS	Coating grades				
										EG55	IG35	TH35	TN35	
R111.0110.00	1.19	3.95	6.7	13.4	8	10.7	2.3	11	111080R	▲	▲	▲	▲	
R111.0130.00	1.39	3.95	6.7	13.4	8	10.7	2.3	11	111080R	▲	▲	▲	▲	
R111.0160.00	1.69	3.95	6.7	13.4	8	10.7	2.3	11	111080R	▲	▲	▲	▲	
L111.0110.00	1.19	3.95	6.7	13.4	8	10.7	2.3	11	111080L	▲	▲	▲	▲	
L111.0130.00	1.39	3.95	6.7	13.4	8	10.7	2.3	11	111080L	▲	▲	▲	▲	
L111.0160.00	1.69	3.95	6.7	13.4	8	10.7	2.3	11	111080L	▲	▲	▲	▲	
										P	●	●	●	●
										M	●	●	●	-
										K	●	●	●	●
										N	-	o	-	o
										S	-	o	-	-
										H	-	-	-	-

Dimensions in mm



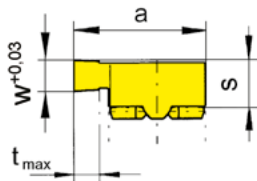
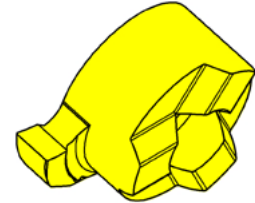
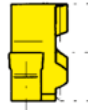
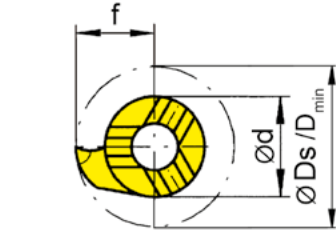
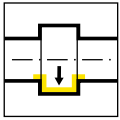

Coating grades

R = right hand version shown

L = left hand version

▲ In stock

Δ 2 weeks

Part number	w	s	f	Ds	d	a	t _{max}	D _{min}	HIS	EG55	IG35	TH35	TN35
R111.0100.1.00	1	3.95	6.7	13.4	8	10.7	2.3	11	111080R	Δ			▲
R111.0150.00	1.5	3.95	6.7	13.4	8	10.7	2.3	11	111080R	▲	▲	▲	▲
R111.0200.00	2	3.95	6.7	13.4	8	10.7	2.3	11	111080R	▲		▲	▲
R111.0250.00	2.5	3.95	6.7	13.4	8	10.7	2.3	11	111080R	▲	▲	▲	▲
R111.0300.00	3	3.95	6.7	13.4	8	10.7	2.3	11	111080R	▲	▲	▲	▲
L111.0100.1.00	1	3.95	6.7	13.4	8	10.7	2.3	11	111080L	Δ			▲
L111.0150.00	1.5	3.95	6.7	13.4	8	10.7	2.3	11	111080L	▲		▲	▲
L111.0200.00	2	3.95	6.7	13.4	8	10.7	2.3	11	111080L	▲		▲	▲
L111.0250.00	2.5	3.95	6.7	13.4	8	10.7	2.3	11	111080L			▲	▲
L111.0300.00	3	3.95	6.7	13.4	8	10.7	2.3	11	111080L	▲		▲	▲

Dimensions in mm

P	●	●	●	●
M	●	●	●	-
K	●	●	●	●
N	-	○	-	○
S	-	○	-	-
H	-	-	-	-

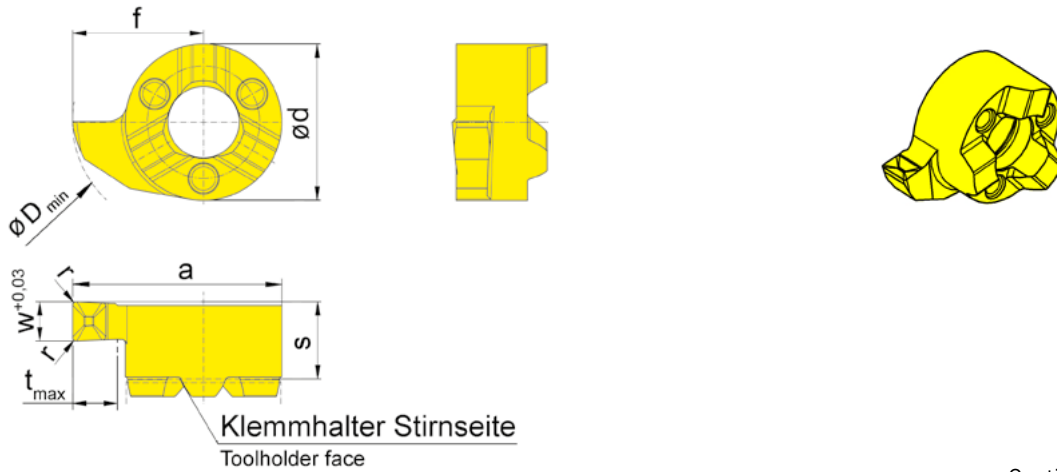
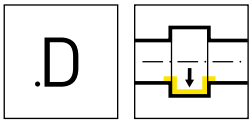

Coating grades

R = right hand version shown

L = left hand version

▲ In stock

△ 2 weeks

Part number	w	s	f	a	r	d	t _{max}	D _{min}	HIS	EG55	TH35	
RS111.0150.D1	1.5	3.95	6.7	10.7	0.1	8	2.3	11	111080R	▲	▲	
RS111.0200.D2	2	3.95	6.7	10.7	0.2	8	2.3	11	111080R	▲	▲	
RS111.0250.D2	2.5	3.95	6.7	10.7	0.2	8	2.3	11	111080R	▲	▲	
LS111.0150.D1	1.5	3.95	6.7	10.7	0.1	8	2.3	11	111080L	△	▲	
LS111.0200.D2	2	3.95	6.7	10.7	0.2	8	2.3	11	111080L	▲	▲	
LS111.0250.D2	2.5	3.95	6.7	10.7	0.2	8	2.3	11	111080L	△	▲	
Dimensions in mm										P	●	●
										M	●	●
										K	●	●
										N	-	-
										S	-	-
										H	-	-



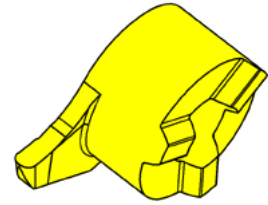
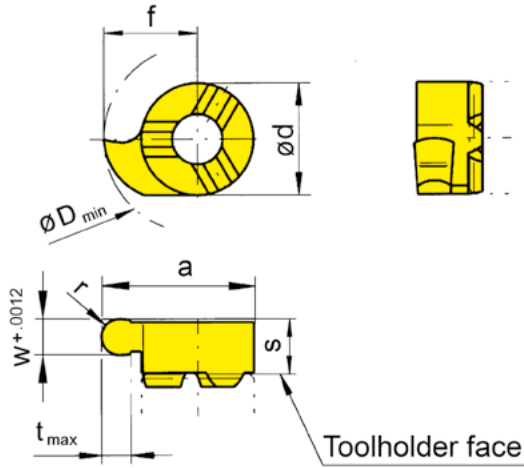
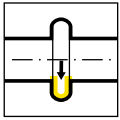

Coating grades

R = right hand version shown

L = left hand version

▲ In stock

Δ 2 weeks

Part number	w	s	f	Ds	a	r	d	t _{max}	D _{min}	HIS	MG12	IG35	TF45	TH35	TN35
RU111.0015.31	.031	.156	.264	.528	.421	.016	.315	.091	.433	111080R		▲		▲	▲
RU111.0023.46	.046	.156	.264	.528	.421	.024	.315	.091	.433	111080R	▲	▲		▲	▲
RU111.0031.62	.062	.156	.264	.528	.421	.031	.315	.091	.433	111080R	▲	▲	Δ	▲	▲
RU111.0039.78	.078	.156	.264	.528	.421	.039	.315	.091	.433	111080R		▲		▲	▲
RU111.0047.94	.094	.156	.264	.528	.421	.047	.315	.091	.433	111080R	▲	▲		▲	▲
LU111.0015.31	.031	.156	.264	.528	.421	.016	.315	.091	.433	111080L		▲			▲
LU111.0023.46	.046	.156	.264	.528	.421	.024	.315	.091	.433	111080L					▲
LU111.0031.62	.062	.156	.264	.528	.421	.031	.315	.091	.433	111080L		▲			▲
LU111.0039.78	.078	.156	.264	.528	.421	.039	.315	.091	.433	111080L					▲
LU111.0047.94	.094	.156	.264	.528	.421	.047	.315	.091	.433	111080L		▲			▲

Dimensions in inch



P	-	●	-	●	●
M	-	●	-	●	-
K	-	●	-	●	●
N	●	○	-	-	○
S	-	○	-	-	-
H	-	-	-	-	-



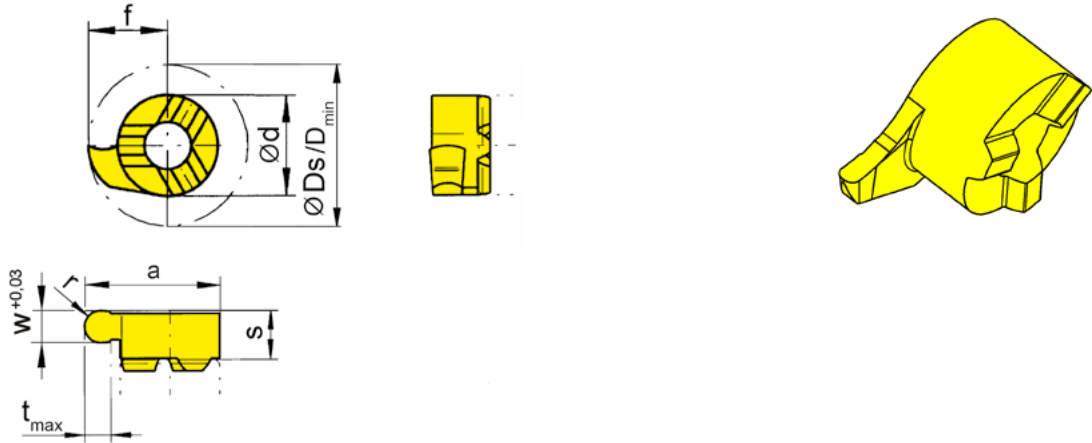
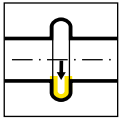

Coating grades

R = right hand version shown

L = left hand version

▲ In stock

Δ 2 weeks

Part number	w	f	Ds	r	d	s	a	t _{max}	D _{min}	HIS	Coating grades				
											EG55	IG35	TH35	TN35	
R111.0004.08	0.8	6.7	13.4	0.4	8	3.95	10.7	2.3	11	111080R	▲		▲	▲	
R111.0006.12	1.2	6.7	13.4	0.6	8	3.95	10.7	2.3	11	111080R	▲	▲	▲	▲	
R111.0009.18	1.8	6.7	13.4	0.9	8	3.95	10.7	2.3	11	111080R	▲		▲	▲	
R111.0010.20	2	6.7	13.4	1	8	3.95	10.7	2.3	11	111080R	▲	▲	▲	▲	
R111.0015.30	3	6.7	13.4	1.5	8	3.95	10.7	2.3	11	111080R	▲	▲	▲	▲	
L111.0004.08	0.8	6.7	13.4	0.4	8	3.95	10.7	2.3	11	111080L	▲		▲	▲	
L111.0006.12	1.2	6.7	13.4	0.6	8	3.95	10.7	2.3	11	111080L	▲		▲	▲	
L111.0009.18	1.8	6.7	13.4	0.9	8	3.95	10.7	2.3	11	111080L		▲	▲	▲	
L111.0010.20	2	6.7	13.4	1	8	3.95	10.7	2.3	11	111080L			▲	▲	
L111.0015.30	3	6.7	13.4	1.5	8	3.95	10.7	2.3	11	111080L			▲	▲	
											P	●	●	●	●
											M	●	●	●	-
											K	●	●	●	●
											N	-	○	-	○
											S	-	○	-	-
											H	-	-	-	-

Dimensions in mm



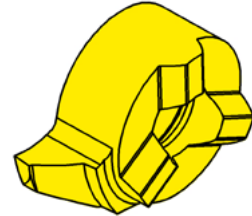
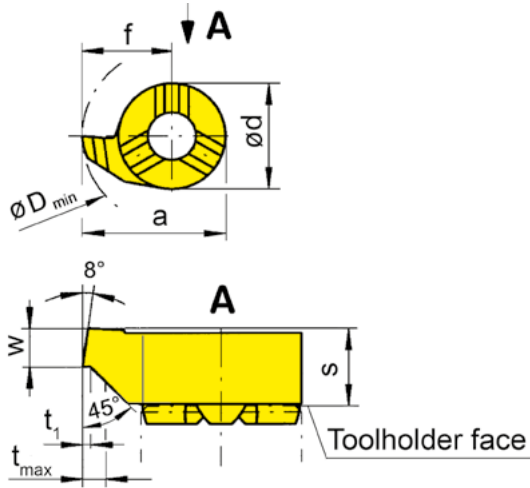
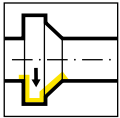

Coating grades

R = right hand version shown

L = left hand version

▲ In stock

Δ 2 weeks

Part number	w	s	a	f	d	t _{max}	t ₁	D _{min}	HIS	EG55	IG35	TI25
R111.0810.45	1	3.95	10.7	6.7	8	1.5	0.2	11	111080R	▲	▲	▲
L111.0810.45	1	3.95	10.7	6.7	8	1.5	0.2	11	111080L	▲	▲	▲

Dimensions in mm

P	●	●	●
M	●	●	●
K	●	●	-
N	-	○	●
S	-	○	-
H	-	-	-

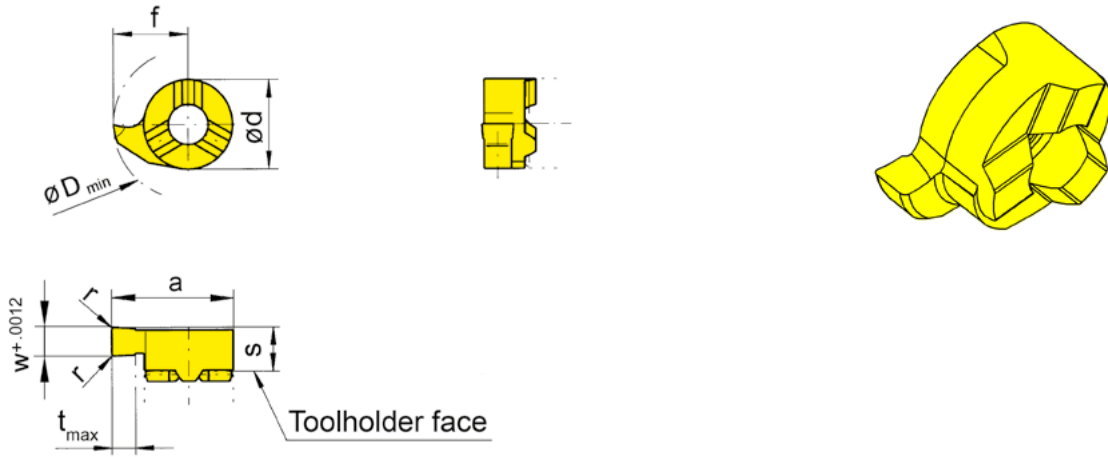
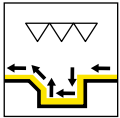

Coating grades

R = right hand version shown

L = left hand version

▲ In stock

Δ 2 weeks

Part number	w	s	f	a	r	d	t _{max}	D _{min}	HIS	Coating grades				
										MG12	IG35	TF45	TH35	TN35
RU111.0031.08	.031	.156	.264	.421	.008	.315	.091	.433	111080R		▲		▲	▲
RU111.0046.08	.046	.156	.264	.421	.008	.315	.091	.433	111080R		▲		▲	▲
RU111.0062.08	.062	.156	.264	.421	.008	.315	.091	.433	111080R	Δ	▲	▲	▲	▲
RU111.0078.08	.078	.156	.264	.421	.008	.315	.091	.433	111080R		▲	Δ	▲	▲
RU111.0094.08	.094	.156	.264	.421	.008	.315	.091	.433	111080R	Δ	▲	Δ	▲	▲
RU111.0125.08	.125	.156	.264	.421	.008	.315	.091	.433	111080R		▲		▲	▲
RU111.0046.16	.046	.156	.264	.421	.016	.315	.091	.433	111080R		▲		▲	▲
RU111.0062.16	.062	.156	.264	.421	.016	.315	.091	.433	111080R		▲		▲	▲
RU111.0078.16	.078	.156	.264	.421	.016	.315	.091	.433	111080R		▲		▲	▲
RU111.0094.16	.094	.156	.264	.421	.016	.315	.091	.433	111080R		▲		▲	▲
RU111.0125.16	.125	.156	.264	.421	.016	.315	.091	.433	111080R		▲		▲	Δ
LU111.0031.08	.031	.156	.264	.421	.008	.315	.091	.433	111080L		▲		▲	▲
LU111.0046.08	.046	.156	.264	.421	.008	.315	.091	.433	111080L		▲		▲	▲
LU111.0062.08	.062	.156	.264	.421	.008	.315	.091	.433	111080L		▲		▲	▲
LU111.0078.08	.078	.156	.264	.421	.008	.315	.091	.433	111080L		▲		▲	▲
LU111.0094.08	.094	.156	.264	.421	.008	.315	.091	.433	111080L		▲		▲	▲
LU111.0062.16	.062	.156	.264	.421	.016	.315	.091	.433	111080L		▲		▲	▲
LU111.0094.16	.094	.156	.264	.421	.016	.315	.091	.433	111080L		▲		▲	Δ
P	-	●	-	●	●									
M	-	●	-	●	-									
K	-	●	-	●	●									
N	●	○	-	-	-	○								
S	-	○	-	-	-									
H	-	-	-	-	-									

These inserts are optimized for finishing passes

Dimensions in inch



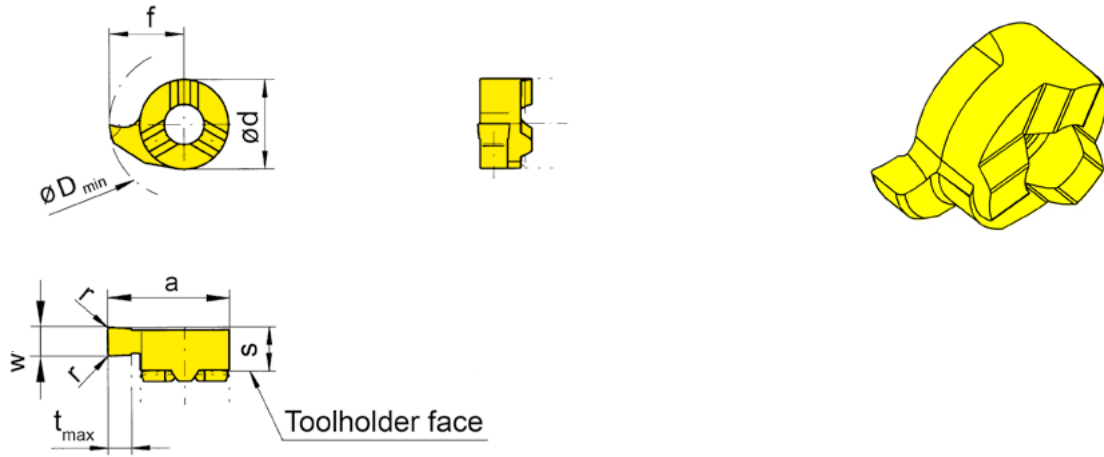
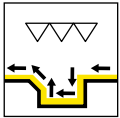

Coating grades

R = right hand version shown

L = left hand version

▲ In stock

Δ 2 weeks

Part number	w	s	f	a	r	d	t _{max}	D _{min}	HIS	EG55	IG35	TH35	TI25	TN35
R111.0200.02	2	3.95	6.7	10.7	0.2	8	2.3	11	111080R	▲	▲	▲	▲	▲
L111.0200.02	2	3.95	6.7	10.7	0.2	8	2.3	11	111080L	▲	▲	▲	Δ	▲

These inserts are optimized for finishing passes

Dimensions in mm

P	●	●	●	●	●
M	●	●	●	●	-
K	●	●	●	-	●
N	-	○	-	●	○
S	-	○	-	-	-
H	-	-	-	-	-

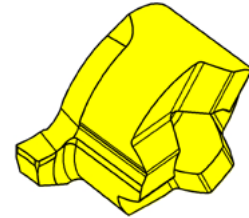
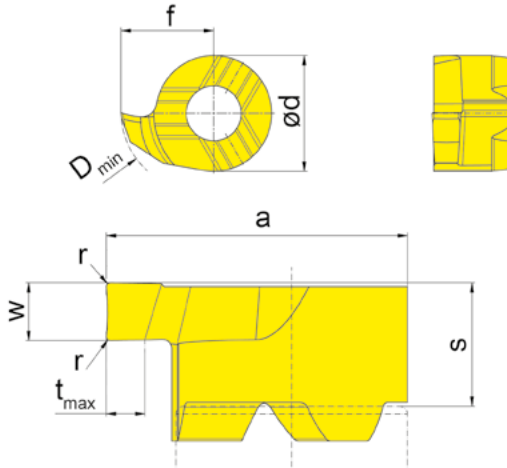
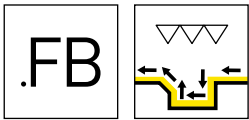

Coating grades

R = right hand version shown

L = left hand version

▲ In stock

Δ 2 weeks

Part number	w	s	f	a	r	d	t _{max}	D _{min}	HIS	EG35
R111.FB10.01	1	3.95	6.7	10.7	0.1	8	2.3	11	111080R	▲
R111.FB15.01	1.5	3.95	6.7	10.7	0.1	8	2.3	11	111080R	▲
L111.FB10.01	1	3.95	6.7	10.7	0.1	8	2.3	11	111080L	▲
L111.FB15.01	1.5	3.95	6.7	10.7	0.1	8	2.3	11	111080L	▲

These inserts feature an optimized geometry that produces a fine surface finish

Dimensions in mm

P	●
M	●
K	●
N	○
S	-
H	-



Smallest possible width of groove calculation, w_x

Example insert: R111.FB10.01

$$w_x = 2 \times \text{Width of insert (w)} - 2 \times \text{Insert corner radius (r)}$$

$$w_x = 2 \times 1 \text{ mm} - 2 \times 0.1 \text{ mm}$$

$$w_x = 1.8 \text{ mm}$$

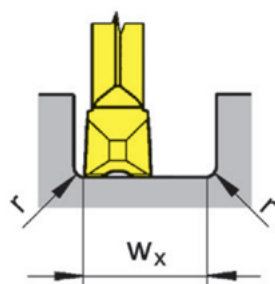

Operation order

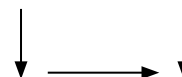

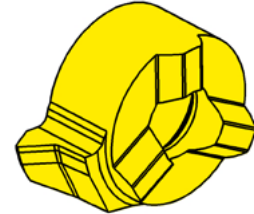
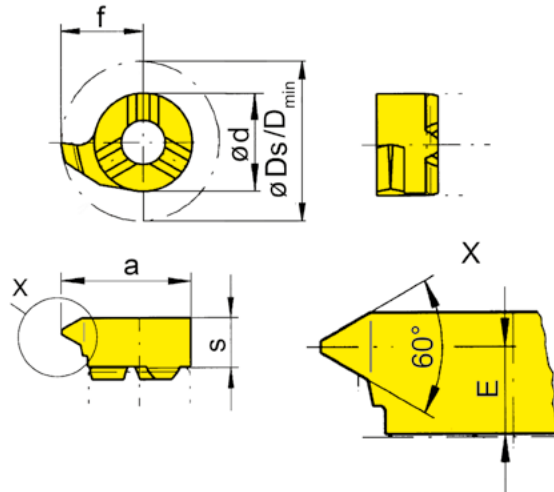
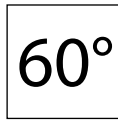
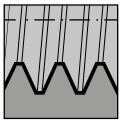

Coating grades

R = right hand version shown

L = left hand version

▲ In stock

△ 2 weeks

Part number	P	TPI	TPI _{max}	E	s	f	a	d	Ds	D _{min}	HIS	Coating grades			
												EG55	IG35	TH35	TN35
R111.0205.01	0.5	28	64	3.5	4.15	6.7	10.7	8	13.4	11	111080R	▲		▲	▲
R111.0510.01	1	18	32	3.3	4.15	6.7	10.7	8	13.4	11	111080R	▲	▲	▲	▲
R111.0815.01	1.5	12	20	3.3	4.15	6.7	10.7	8	13.4	11	111080R	▲	▲	▲	▲
R111.1020.01	2	11	16	3	4.15	6.7	10.7	8	13.4	11	111080R	▲	▲	▲	▲
R111.1325.01	2.5	9	12	2.8	4.15	6.7	10.7	8	13.4	11	111080R	▲	▲	▲	▲
L111.0205.01	0.5	28	64	3.5	4.15	6.7	10.7	8	13.4	11	111080L	△		▲	▲
L111.0510.01	1	18	32	3.3	4.15	6.7	10.7	8	13.4	11	111080L	▲	▲	▲	▲
L111.0815.01	1.5	12	20	3.3	4.15	6.7	10.7	8	13.4	11	111080L	▲		▲	▲
L111.1020.01	2	11	16	3	4.15	6.7	10.7	8	13.4	11	111080L	△		▲	▲
L111.1325.01	2.5	9	12	2.8	4.15	6.7	10.7	8	13.4	11	111080L	△		▲	▲

Dimensions in mm

	P	M	K	N	S	H
EG55	●	●	●	-	-	-
IG35	●	●	●	○	○	-
TH35	●	●	●	-	-	-
TN35	●	-	●	○	-	-

H

Insert

S111 $\varnothing \geq 11$ mm

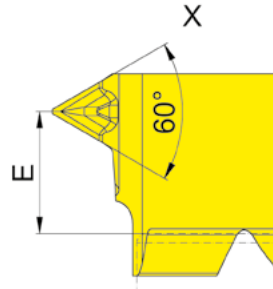
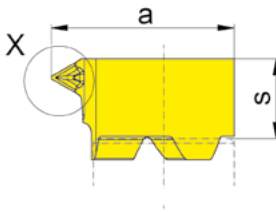
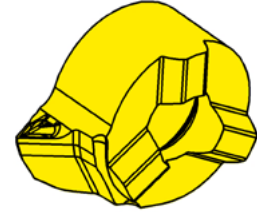
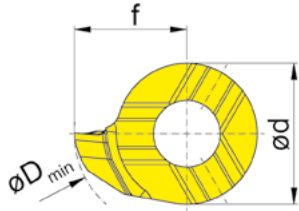

Coating grades

R = right hand version shown

▲ In stock

Δ 2 weeks

Part number	P	TPI	TPI _{max}	E	f	a	d	s	D _{min}	HIS	EG55
RS111.0205.GM1	0.5	28	64	3.1	6.7	10.7	8	4.1	11	111080R	▲
RS111.0510.GM1	1	18	32	3.1	6.7	10.7	8	4.1	11	111080R	▲
RS111.0815.GM1	1.5	12	20	3.1	6.7	10.7	8	4.1	11	111080R	▲
RS111.1020.GM1	2	11	16	3.1	6.7	10.7	8	4.1	11	111080R	▲
LS111.0205.GM1	0.5	28	64	3.1	6.7	10.7	8	4.1	11	111080L	▲
LS111.0510.GM1	1	18	32	3.1	6.7	10.7	8	4.1	11	111080L	▲
LS111.0815.GM1	1.5	12	20	3.1	6.7	10.7	8	4.1	11	111080L	▲
LS111.1020.GM1	2	11	16	3.1	6.7	10.7	8	4.1	11	111080L	▲

Dimensions in mm

P	●
M	●
K	●
N	-
S	-
H	-



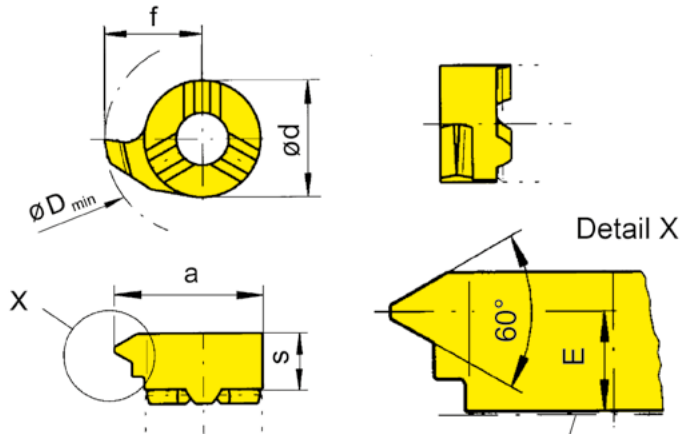

Klemhalter Stirnseite
Toolholder face

Coating grades

R = right hand version shown

L = left hand version

▲ In stock

△ 2 weeks

Part number	P	E	f	a	d	s	D _{min}	HIS	EG55	TN35
R111.0510.02	1	3.3	6.7	10.7	8	4.15	11	111080R	▲	▲
R111.0815.02	1.5	3.3	6.7	10.7	8	4.15	11	111080R	▲	▲
R111.1020.02	2	3	6.7	10.7	8	4.15	11	111080R	▲	▲
R111.1325.02	2.5	2.8	6.7	10.7	8	4.15	11	111080R	▲	▲
R111.1630.02	3	2.8	6.7	10.7	8	4.15	11	111080R	▲	▲
L111.0510.02	1	3.3	6.7	10.7	8	4.15	11	111080L	△	▲
L111.0815.02	1.5	3.3	6.7	10.7	8	4.15	11	111080L	▲	▲
L111.1020.02	2	3	6.7	10.7	8	4.15	11	111080L	▲	▲
L111.1325.02	2.5	2.8	6.7	10.7	8	4.15	11	111080L	△	▲
L111.1630.02	3	2.8	6.7	10.7	8	4.15	11	111080L	△	△

Dimensions in mm

P	●	●
M	●	-
K	●	●
N	-	o
S	-	-
H	-	-

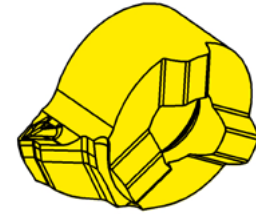
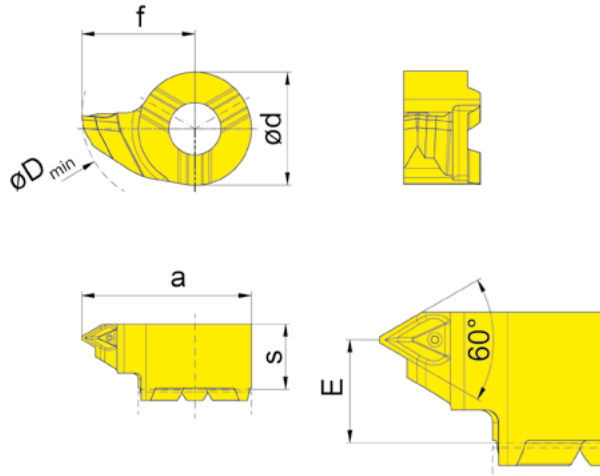

Coating grades

R = right hand version shown

▲ In stock

Δ 2 weeks

Part number	P	E	f	a	d	s	D _{min}	HIS	EG55
RS111.0510.GM2	1	3.1	6.7	10.7	8	4.1	11	111080R	▲
RS111.0815.GM2	1.5	3.1	6.7	10.7	8	4.1	11	111080R	▲
RS111.1020.GM2	2	3.1	6.7	10.7	8	4.1	11	111080R	▲
LS111.0510.GM2	1	3.1	6.7	10.7	8	4.1	11	111080L	▲
LS111.0815.GM2	1.5	3.1	6.7	10.7	8	4.1	11	111080L	▲
LS111.1020.GM2	2	3.1	6.7	10.7	8	4.1	11	111080L	▲

Dimensions in mm

P	●
M	●
K	●
N	-
S	-
H	-



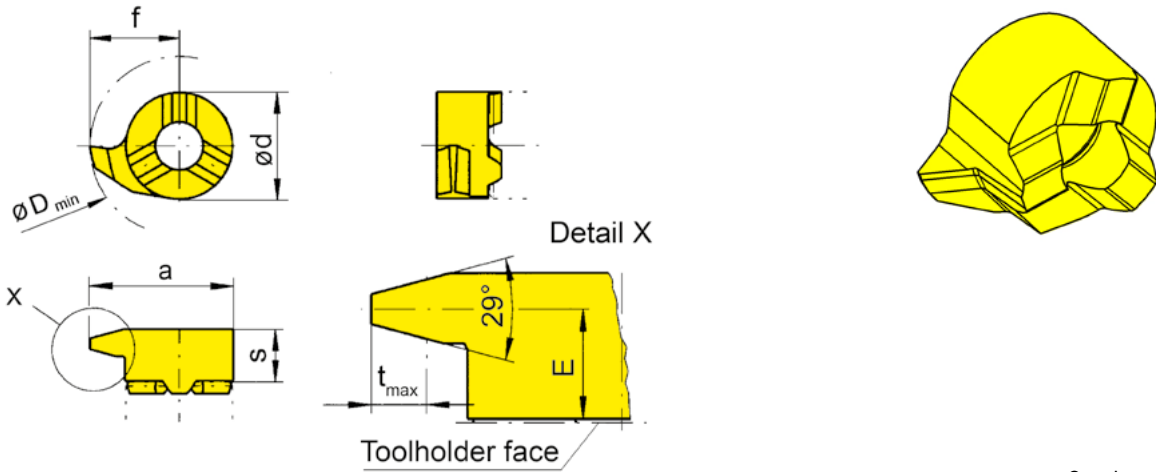

Coating grades

R = right hand version shown

▲ In stock

△ 2 weeks

Part number	TPI	E	f	a	d	s	t _{max}	D _{min}	HIS	Coating grades			
										MG12	IG35	TH35	TN35
RU111.AC06.01	6	.106	.264	.057	.315	.163	.093	.433	111080R		▲	▲	▲
RU111.AC08.01	8	.118	.264	.041	.315	.163	.072	.433	111080R	▲	▲	▲	▲
RU111.SA05.01	5	.150	.402	.618	.433	.217	.070	.630	111080R		▲	▲	△
RU111.SA06.01	6	.157	.382	.618	.433	.217	.060	.630	111080R		▲	▲	▲
RU111.SA08.01	8	.112	.264	.048	.315	.163	.048	.433	111080R		▲	▲	▲
RU111.SA10.01	10	.126	.264	.037	.315	.163	.040	.433	111080R		▲	▲	▲
LU111.AC06.01	6	.106	.264	.057	.315	.163	.093	.433	111080L		▲	▲	▲
LU111.AC08.01	8	.118	.264	.041	.315	.163	.072	.433	111080L	▲	▲		▲
LU111.SA06.01	6	.157	.382	.618	.433	.217	.060	.630	111080L				△
LU111.SA08.01	8	.112	.264	.048	.315	.163	.048	.433	111080L		▲		▲
LU111.SA10.01	10	.126	.264	.037	.315	.163	.040	.433	111080L		▲		▲

Inserts with ".AC" are designed for standard ACME threads. Inserts with ".SA" are designed for stub ACME threads.

Dimensions in inch



P	-	●	●	●
M	-	●	●	-
K	-	●	●	●
N	●	○	-	○
S	-	○	-	-
H	-	-	-	-

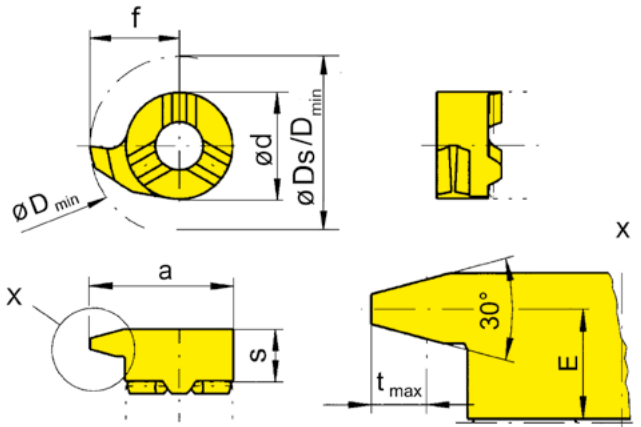

Coating grades

R = right hand version shown

L = left hand version

▲ In stock

△ 2 weeks

Part number	P	E	f	a	d	s	t _{max}	D _{min}	D _s	HIS	EG55	TN35
R111.1015.01	1.5	3.5	6.7	10.7	8	4.15	0.9	11	13.4	111080R	▲	▲
R111.1220.01	2	3.3	6.7	10.7	8	4.15	1.25	11	13.4	111080R	▲	▲
R111.1730.01	3	3	6.7	10.7	8	4.15	1.75	11	13.4	111080R	▲	▲
R111.2240.01	4	2.5	6.7	10.7	8	4.15	2.25	11	13.4	111080R	▲	▲
L111.1015.01	1.5	3.5	6.7	10.7	8	4.15	0.9	11	13.4	111080L	△	△
L111.1220.01	2	3.3	6.7	10.7	8	4.15	1.25	11	13.4	111080L	▲	▲
L111.1730.01	3	3	6.7	10.7	8	4.15	1.75	11	13.4	111080L	▲	▲
L111.2240.01	4	2.5	6.7	10.7	8	4.15	2.25	11	13.4	111080L	▲	▲

These inserts produce a trapezoidal thread profile

Dimensions in mm

P	●	●
M	●	-
K	●	●
N	-	o
S	-	-
H	-	-



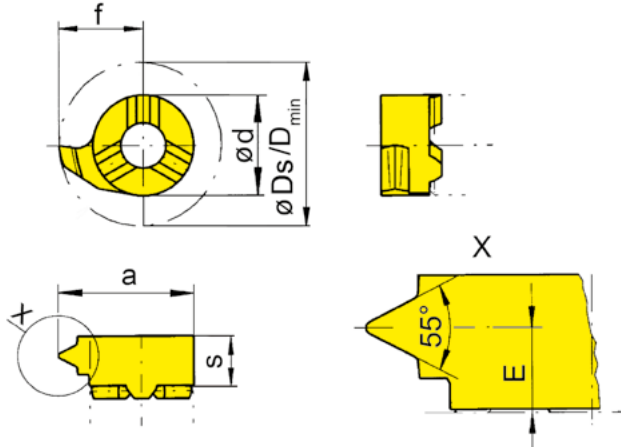

Coating grades

R = right hand version shown

L = left hand version

▲ In stock

△ 2 weeks

Part number	TPI	E	s	f	a	d	D _s	D _{min}	HIS	EG55	TN35
R111.5514.02	14	2.5	4.15	6.7	10.7	8	13.4	11	111080R	▲	▲
R111.5519.02	19	2.9	4.15	6.7	10.7	8	13.4	11	111080R	▲	▲
L111.5514.02	14	2.5	4.15	6.7	10.7	8	13.4	11	111080L	△	▲
L111.5519.02	19	2.9	4.15	6.7	10.7	8	13.4	11	111080L		▲

These inserts produce a Whitworth thread profile

Dimensions in mm

P	●	●
M	●	-
K	●	●
N	-	○
S	-	-
H	-	-



MINI 11P

Bore Ø		Tool System											
mm	in	105	109	110	106	107	108	10P	111	11P	114	116	18P
≥ 0.2	≥ .0079	•											
≥ 0.5	≥ .0197	•											
≥ 0.7	≥ .0276	•											
≥ 1.0	≥ .0394	•											
≥ 1.5	≥ .0591	•											
≥ 2.0	≥ .0787	•											
≥ 3.0	≥ .1181	•											
≥ 4.0	≥ .1575	•											
≥ 5.0	≥ .1969	•											
≥ 6.0	≥ .2362	•	•	•	•								
≥ 6.8	≥ .2677		•	•	•								
≥ 7.0	≥ .2756		•			•							
≥ 7.8	≥ .3071			•		•	•						
≥ 8.0	≥ .3150			•		•	•						
≥ 9.0	≥ .3543			•		•	•	•					
≥ 10.0	≥ .3937			•				•	•	•			
≥ 10.5	≥ .4134									•			
≥ 11.0	≥ .4331								•	•			
≥ 11.5	≥ .4528									•			
≥ 13.8	≥ .5433										•		
≥ 14.0	≥ .5512										•	•	
≥ 16.0	≥ .6299									•		•	
≥ 16.5	≥ .6496										(•)		
≥ 18.0	≥ .7087												•
Depth of groove		2.5	2.5	4.0	0.8	2.0	1.0	3.0	2.3	3.5	4.0, (6.5)	4.3	8.0
		.0984	.0984	.1575	.0315	.0787	.0394	.1181	.0906	.1378	.1575, (.2559)	.1693	.3150
Width of groove		0.5-2.0	1.0-2.0	1.0-3.0	0.7-1.5	1.0-2.0	0.7-2.0	1.0-3.0	0.7-3.0	1.0-3.0	0.7-3.0	0.7-4.0	2.0-3.0
		.0197- .0787	.0394- .0787	.0394- .1181	.0276- .0591	.0394- .0787	.0276- .0787	.0394- .1181	.0276- .1181	.0394- .1181	.0276- .1181	.0276- .1575	.0787- .1181
Operations													
Grooving		•	•	•	•	•	•	•	•	•	•	•	•
Boring		•	•	•	•	•	•		•		•	•	
Threading		•	•			•	•		•		•	•	
Chamfering		•	•			•	•		•		•	•	
Face Grooving		•	•	•							•		
Boring and Profiling		•					•	•	•	•	•	•	

HOLDERS

Round Shank

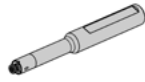

Page 333
Holder BU11P
Inch Shank

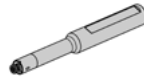

Page 334-335
Holder B11P

INSERTS

Boring

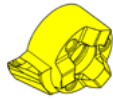

Page 336
Bore Contouring
.R Chipbreaker



Page 337
Bore Contouring



Page 338
Bore Contouring
and Profiling



Page 339
Back Boring



Page 340
Chamfering, Profi-
ling, Back Boring

Grooving



Page 341, 343
Grooving



Page 342, 344
Grooving
.D Chipbreaker

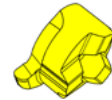

Page 345
Grooving
Full Radius

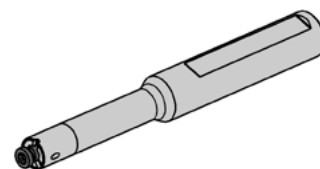
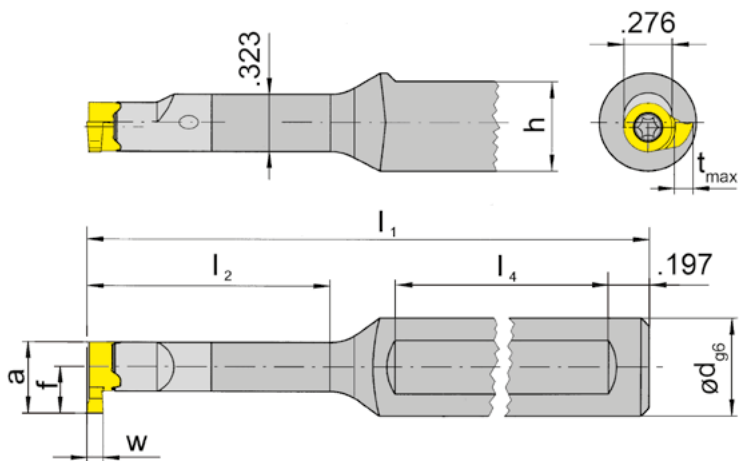
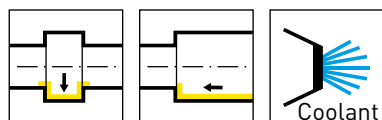

R = right hand version shown

L = left hand version

Part number	d	l_1	l_2	h	l_4	HWS
RBU11P.0500.00	.500	2.953	.591	.461	1.575	11P070R
RBU11P.0500.01	.500	3.740	1.024	.461	1.772	11P070R
RBU11P.0500.02	.500	4.331	1.457	.461	1.772	11P070R
LBU11P.0500.00	.500	2.953	.591	.461	1.575	11P070L
LBU11P.0500.01	.500	3.740	1.024	.461	1.772	11P070L
LBU11P.0500.02	.500	4.331	1.457	.461	1.772	11P070L

For w, a, tmax and f dimensions, see insert pages

Dimensions in inch



Spare Parts

Toolholder	Clamping Screw	TORX PLUS® Wrench	Torque Value
R/LBU11P...	3.10T9P	T9PL	1.8 Nm

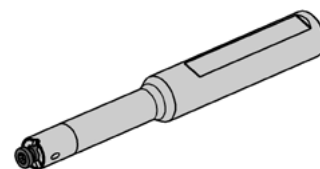
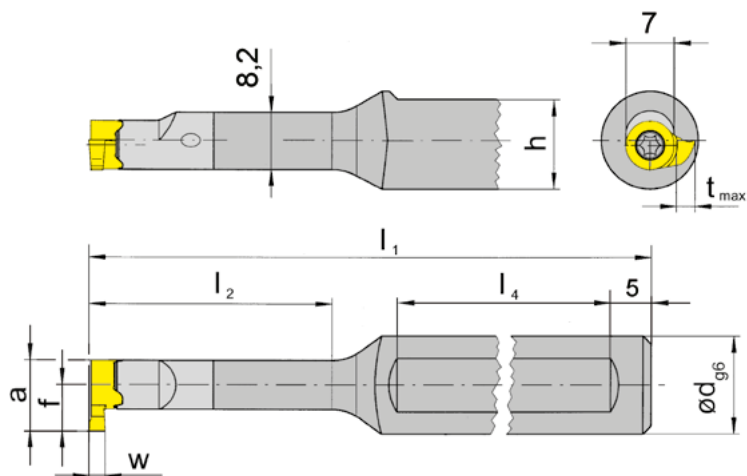
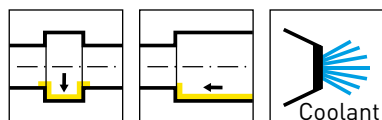

R = right hand version shown

L = left hand version

Part number	d	l ₁	l ₂	h	l ₄	HWS
RB11P.0012.00	12	75	15	11	40	11P070R
RB11P.0012.01	12	95	26	11	50	11P070R
RB11P.0012.02	12	110	37	11	50	11P070R
RB11P.0012.03	12	120	50	11	50	11P070R
LB11P.0012.00	12	75	15	11	40	11P070L
LB11P.0012.01	12	95	26	11	50	11P070L
LB11P.0012.02	12	110	37	11	50	11P070L
LB11P.0012.03	12	120	50	11	50	11P070L

For w, a, t_{max} and f dimensions, see insert pages

1 clamping flat

Dimensions in mm

Spare Parts

Toolholder	Clamping Screw	TORX PLUS® Wrench	Torque Value
R/LB11P...	3.10T9P	T9PL	1.8 Nm

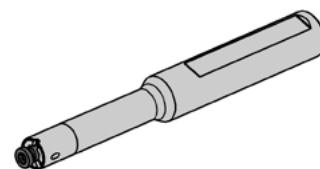
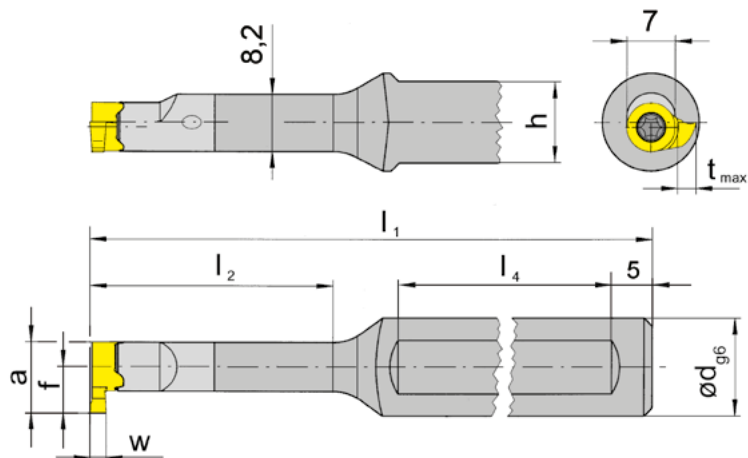
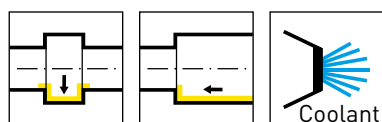

R = right hand version shown

L = left hand version

Part number	d	l ₁	l ₂	h	l ₄	HWS
RB11P.0012.2.00	12	75	15	11	40	11P070R
RB11P.0012.2.01	12	95	26	11	50	11P070R
RB11P.0012.2.02	12	110	37	11	50	11P070R
RB11P.0012.2.03	12	120	50	11	50	11P070R
LB11P.0012.2.00	12	75	15	11	40	11P070L
LB11P.0012.2.01	12	95	26	11	50	11P070L
LB11P.0012.2.02	12	110	37	11	50	11P070L
LB11P.0012.2.03	12	120	50	11	50	11P070L

For w, a, t_{max} and f dimensions, see insert pages

2 clamping flats

Dimensions in mm

Spare Parts

Toolholder	Clamping Screw	TORX PLUS® Wrench	Torque Value
R/LB11P...	3.10T9P	T9PL	1.8 Nm

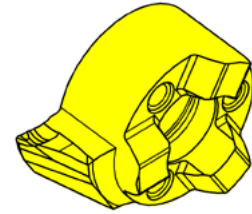
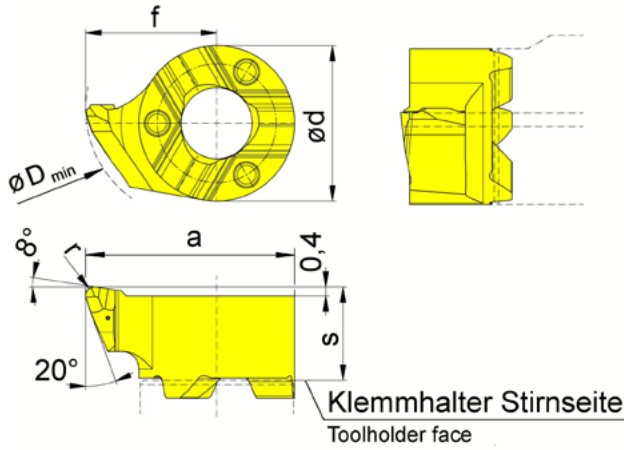
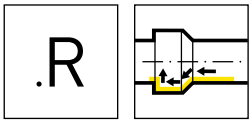

Coating grades

R = right hand version shown

L = left hand version

▲ In stock

△ 2 weeks

Part number	s	f	a	r	d	D _{min}	HIS	Coating grades	
								EG55	TH35
RS11P.1859.R2	4.2	5.9	9.4	0.2	7	9.8	11P070R	▲	▲
RS11P.1859.R4	4.2	5.9	9.4	0.4	7	9.8	11P070R	▲	▲
LS11P.1859.R2	4.2	5.9	9.4	0.2	7	9.8	11P070L		▲
LS11P.1859.R4	4.2	5.9	9.4	0.4	7	9.8	11P070L	▲	▲

Dimensions in mm

	P	M	K	N	S	H
EG55	●	●	●	-	-	-
TH35	●	●	●	-	-	-



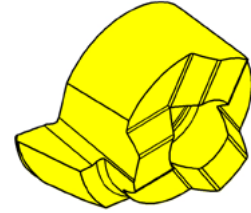
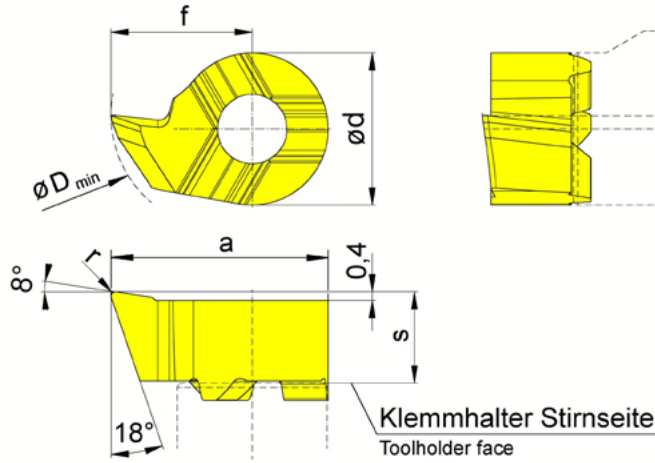
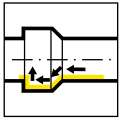

Coating grades

R = right hand version shown

L = left hand version

▲ In stock

Δ 2 weeks

Part number	s	f	a	r	d	D _{min}	HIS	EG55	IG35	TH35
R11P.1865.1.02	4.2	6.5	10	0.2	7	10.5	11P070R	▲	▲	▲
L11P.1865.1.02	4.2	6.5	10	0.2	7	10.5	11P070L	▲	▲	▲

Dimensions in mm

P	●	●	●
M	●	●	●
K	●	●	●
N	-	○	-
S	-	○	-
H	-	-	-

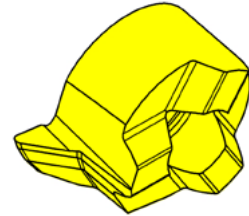
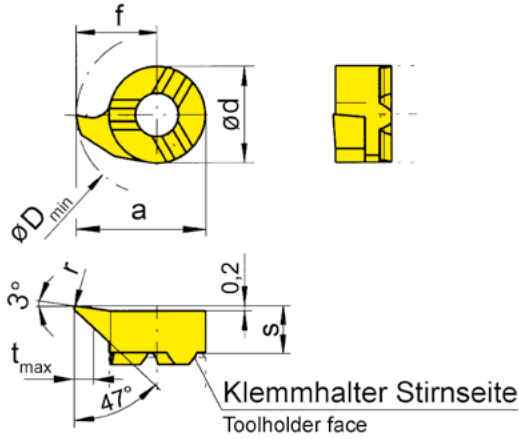
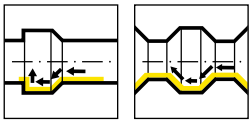

Coating grades

R = right hand version shown

L = left hand version

▲ In stock

Δ 2 weeks

Part number	s	f	a	r	d	t _{max}	D _{min}	HIS	EG55
R11P.4775.2.02	4.2	7.5	11	0.2	7	3.5	11.5	11P070R	▲
L11P.4775.2.02	4.2	7.5	11	0.2	7	3.5	11.5	11P070L	Δ

Dimensions in mm

P	●
M	●
K	●
N	-
S	-
H	-



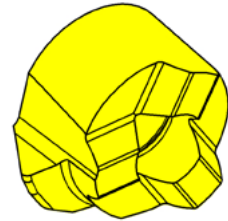
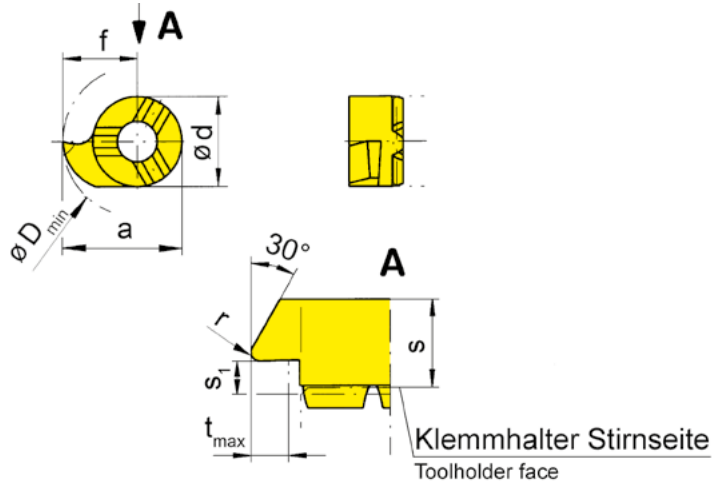
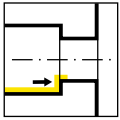

Coating grades

R = right hand version shown

L = left hand version

▲ In stock

Δ 2 weeks

Part number	s	f	a	r	s ₁	d	t _{max}	D _{min}	HIS	EG55
R11P.3075.2.02	4.35	7.5	11	0.2	1.6	7	3.5	11.5	11P070R	▲
L11P.3075.2.02	4.35	7.5	11	0.2	1.6	7	3.5	11.5	11P070L	▲

Dimensions in mm

P	●
M	●
K	●
N	-
S	-
H	-

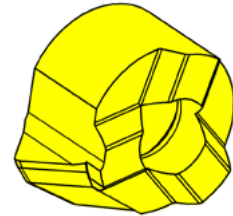
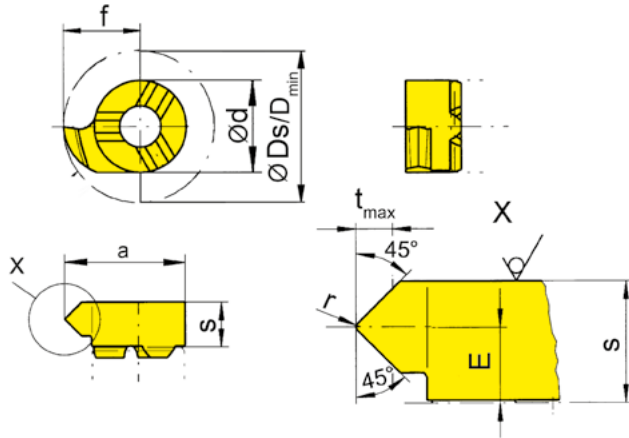
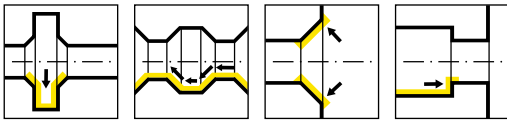

Coating grades

R = right hand version shown

L = left hand version

▲ In stock

Δ 2 weeks

Part number	E	f	r	d	s	a	D_{\min}	α	t_{\max}	HIS	EG55
R11P.4545.1.02	2.2	6.5	0.2	7	4.35	10	10.5	45°	1.7	11P070R	▲
L11P.4545.1.02	2.2	6.5	0.2	7	4.35	10	10.5	45°	1.7	11P070L	Δ

Dimensions in mm

P	●
M	●
K	●
N	-
S	-
H	-



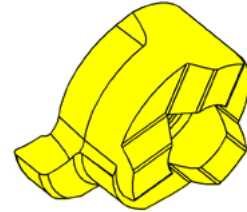
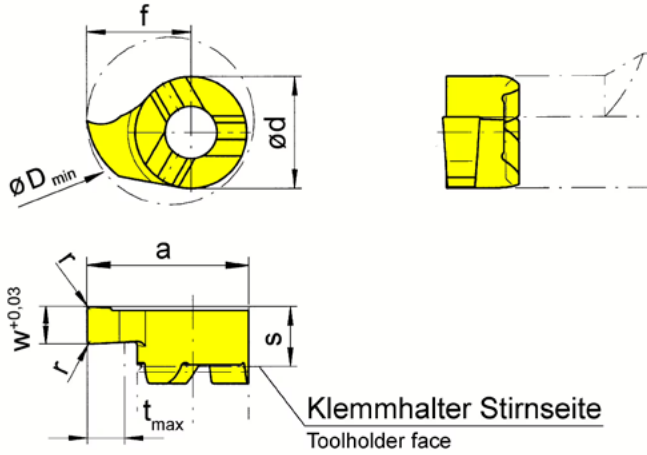
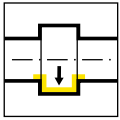

Coating grades

R = right hand version shown

L = left hand version

▲ In stock

△ 2 weeks

Part number	w	s	f	a	r	d	t _{max}	D _{min}	HIS	Coating grades		
										EG55	IG35	TH35
R11P.0100.1.00	1	4.2	6.5	10	-	7	2.5	10.5	11P070R		▲	▲
R11P.0150.1.00	1.5	4.2	6.5	10	-	7	2.5	10.5	11P070R	▲		▲
R11P.0200.1.02	2	4.2	6.5	10	0.2	7	2.5	10.5	11P070R		▲	▲
R11P.0250.1.02	2.5	4.2	6.5	10	0.2	7	2.5	10.5	11P070R	▲		▲
R11P.0300.1.02	3	4.2	6.5	10	0.2	7	2.5	10.5	11P070R	▲	▲	▲
L11P.0100.1.00	1	4.2	6.5	10	-	7	2.5	10.5	11P070L	△		▲
L11P.0150.1.00	1.5	4.2	6.5	10	-	7	2.5	10.5	11P070L	△		▲
L11P.0200.1.02	2	4.2	6.5	10	0.2	7	2.5	10.5	11P070L	▲		▲
L11P.0250.1.02	2.5	4.2	6.5	10	0.2	7	2.5	10.5	11P070L	△		▲
L11P.0300.1.02	3	4.2	6.5	10	0.2	7	2.5	10.5	11P070L	△		▲

Inserts ending in “.00” have a “.002” x 45° (0.05mm) corner chamfer. Inserts ending in “.02” feature the corner radius listed in the table

Dimensions in mm

	P	M	K	N	S	H
EG55	●	●	●	-	-	-
IG35	●	●	●	○	○	-
TH35	●	●	●	-	-	-

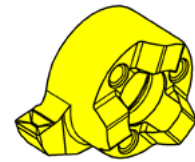
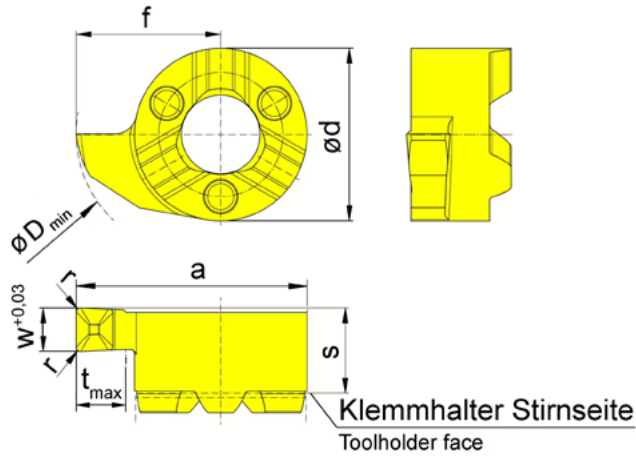
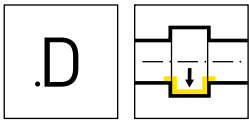

Coating grades

R = right hand version shown

L = left hand version

▲ In stock

△ 2 weeks

Part number	w	s	f	a	r	d	t _{max}	D _{min}	HIS	EG55	TH35
RS11P.0150.1.D1	1.5	4.2	6.5	10	0.1	7	2.5	10.5	11P070R	▲	▲
RS11P.0200.1.D2	2	4.2	6.5	10	0.2	7	2.5	10.5	11P070R	▲	▲
RS11P.0250.1.D2	2.5	4.2	6.5	10	0.2	7	2.5	10.5	11P070R	▲	▲
LS11P.0150.1.D1	1.5	4.2	6.5	10	0.1	7	2.5	10.5	11P070L	△	▲
LS11P.0200.1.D2	2	4.2	6.5	10	0.2	7	2.5	10.5	11P070L	△	▲
LS11P.0250.1.D2	2.5	4.2	6.5	10	0.2	7	2.5	10.5	11P070L	△	▲

Dimensions in mm

P	●	●
M	●	●
K	●	●
N	-	-
S	-	-
H	-	-

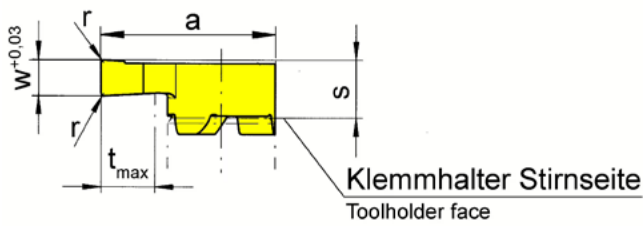
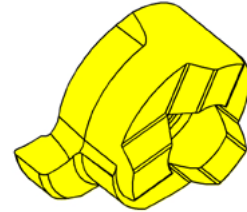
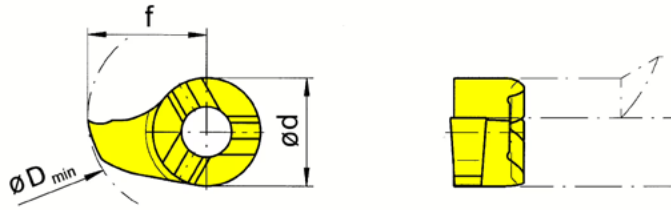
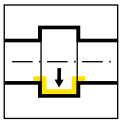

R = right hand version shown

L = left hand version

▲ In stock

Δ 2 weeks

Coating grades

Part number	w	s	f	a	r	d	t _{max}	D _{min}	HIS	Coating grades		
										EG55	IG35	TH35
R11P.0100.2.00	1	4.2	7.5	11	-	7	3.5	11.5	11P070R	▲		▲
R11P.0150.2.00	1.5	4.2	7.5	11	-	7	3.5	11.5	11P070R	▲		▲
R11P.0200.2.02	2	4.2	7.5	11	0.2	7	3.5	11.5	11P070R	▲	▲	▲
L11P.0100.2.00	1	4.2	7.5	11	-	7	3.5	11.5	11P070L	Δ		▲
L11P.0150.2.00	1.5	4.2	7.5	11	-	7	3.5	11.5	11P070L	Δ		▲
L11P.0200.2.02	2	4.2	7.5	11	0.2	7	3.5	11.5	11P070L	▲		▲

Inserts ending in ".00" have a .002" x 45° (0.05mm) corner chamfer. Inserts ending in ".02" feature the corner radius listed in the table

Dimensions in mm

P	●	●	●
M	●	●	●
K	●	●	●
N	-	o	-
S	-	o	-
H	-	-	-

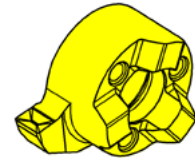
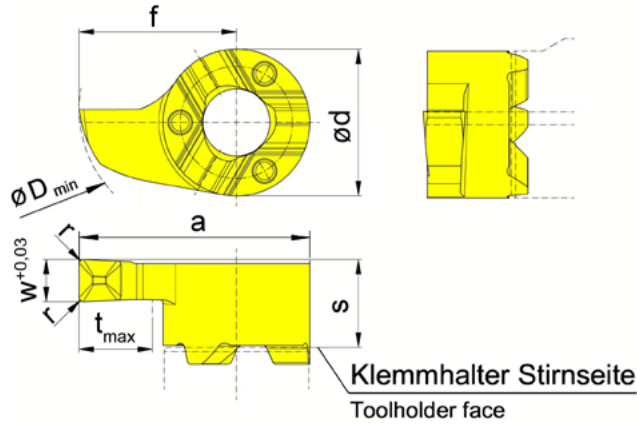
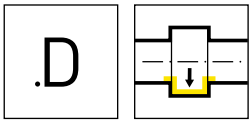

Coating grades

R = right hand version shown

L = left hand version

▲ In stock

Δ 2 weeks

Part number	w	s	f	a	r	d	t _{max}	D _{min}	HIS	EG55	TH35
RS11P.0150.2.D1	1.5	4.2	7.5	11	0.1	7	3.5	11.5	11P070R	▲	▲
RS11P.0200.2.D2	2	4.2	7.5	11	0.2	7	3.5	11.5	11P070R	▲	▲
RS11P.0250.2.D2	2.5	4.2	7.5	11	0.2	7	3.5	11.5	11P070R	▲	▲
LS11P.0150.2.D1	1.5	4.2	7.5	11	0.1	7	3.5	11.5	11P070L	Δ	▲
LS11P.0200.2.D2	2	4.2	7.5	11	0.2	7	3.5	11.5	11P070L	▲	▲
LS11P.0250.2.D2	2.5	4.2	7.5	11	0.2	7	3.5	11.5	11P070L	Δ	▲

Dimensions in mm

P	●	●
M	●	●
K	●	●
N	-	-
S	-	-
H	-	-

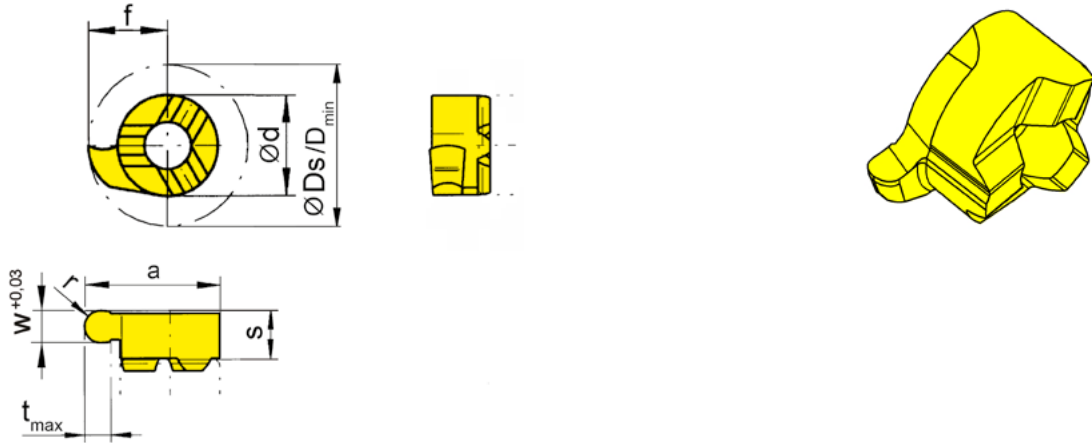
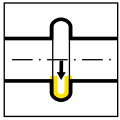

Coating grades

R = right hand version shown

L = left hand version

▲ In stock

△ 2 weeks

Part number	w	s	f	a	r	d	t _{max}	D _{min}	HIS	EG55
R11P.0005.2.10	1	4.2	7.5	11	0.5	7	3.5	11.5	11P070R	▲
R11P.0007.2.15	1.5	4.2	7.5	11	0.75	7	3.5	11.5	11P070R	▲
R11P.0009.2.18	1.8	4.2	7.5	11	0.9	7	3.5	11.5	11P070R	▲
R11P.0010.2.20	2	4.2	7.5	11	1	7	3.5	11.5	11P070R	▲
L11P.0005.2.10	1	4.2	7.5	11	0.5	7	3.5	11.5	11P070L	▲
L11P.0007.2.15	1.5	4.2	7.5	11	0.75	7	3.5	11.5	11P070L	▲
L11P.0009.2.18	1.8	4.2	7.5	11	0.9	7	3.5	11.5	11P070L	▲
L11P.0010.2.20	2	4.2	7.5	11	1	7	3.5	11.5	11P070L	▲

Dimensions in mm

P	●
M	●
K	●
N	-
S	-
H	-



J

MINI 114

Bore Ø		Tool System											
mm	in	105	109	110	106	107	108	10P	111	11P	114	116	18P
≥ 0.2	≥ .0079	•											
≥ 0.5	≥ .0197	•											
≥ 0.7	≥ .0276	•											
≥ 1.0	≥ .0394	•											
≥ 1.5	≥ .0591	•											
≥ 2.0	≥ .0787	•											
≥ 3.0	≥ .1181	•											
≥ 4.0	≥ .1575	•											
≥ 5.0	≥ .1969	•											
≥ 6.0	≥ .2362	•	•	•	•								
≥ 6.8	≥ .2677		•	•	•								
≥ 7.0	≥ .2756		•			•							
≥ 7.8	≥ .3071			•		•	•						
≥ 8.0	≥ .3150			•		•	•						
≥ 9.0	≥ .3543			•		•	•	•					
≥ 10.0	≥ .3937			•				•	•	•			
≥ 10.5	≥ .4134									•			
≥ 11.0	≥ .4331								•	•			
≥ 11.5	≥ .4528									•			
≥ 13.8	≥ .5433										•		
≥ 14.0	≥ .5512										•	•	
≥ 16.0	≥ .6299									•		•	
≥ 16.5	≥ .6496										(•)		
≥ 18.0	≥ .7087												•
Depth of groove		2.5	2.5	4.0	0.8	2.0	1.0	3.0	2.3	3.5	4.0, (6.5)	4.3	8.0
		.0984	.0984	.1575	.0315	.0787	.0394	.1181	.0906	.1378	.1575, (.2559)	.1693	.3150
Width of groove		0.5-2.0	1.0-2.0	1.0-3.0	0.7-1.5	1.0-2.0	0.7-2.0	1.0-3.0	0.7-3.0	1.0-3.0	0.7-3.0	0.7-4.0	2.0-3.0
		.0197-.0787	.0394-.0787	.0394-.1181	.0276-.0591	.0394-.0787	.0276-.0787	.0394-.1181	.0276-.1181	.0394-.1181	.0276-.1181	.0276-.1575	.0787-.1181
Operations													
Grooving		•	•	•	•	•	•	•	•	•	•	•	•
Boring		•	•	•	•	•	•		•		•	•	
Threading		•	•			•	•		•		•	•	
Chamfering		•	•			•	•		•		•	•	
Face Grooving		•	•	•									
Boring and Profiling		•					•	•	•	•	•	•	



HOLDERS

Round Shank

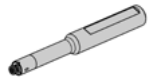

Page 350
Holder BU114
Inch Shank

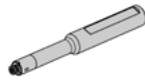

Page 351-352
Holder B114

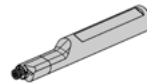

Page 353
Holder BAU114
Inch, Face Grooving

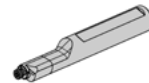

Page 354
Holder BA114
Face Grooving

Square Shank

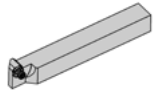

Page 355
Holder HCU114
Inch Shank

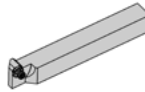

Page 356
Holder HC114



Page 357
Holder WFB

Specialty

INSERTS

Boring



Page 358
Bore Contouring

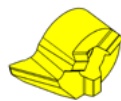

Page 359-360
Bore Contouring
and Profiling

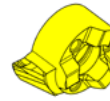

Page 361
Bore Contouring
.R Chipbreaker

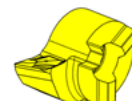

Page 362
Boring
.I Chipbreaker



Page 363
Back Boring



Page 364
Chamfering, Profi-
ling, Back Boring

Grooving

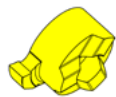

Page 365, 370
Grooving
Inch

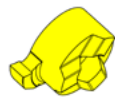

Page 366-368, 371
Grooving

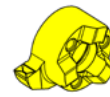

Page 369, 372
Grooving
.D Chipbreaker



Page 373
Grooving
Full Radius, Inch

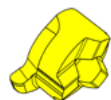

Page 374
Grooving
Full Radius



Page 375
Pre-Part Off





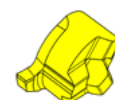



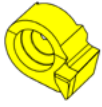

Page 376-377
Fine Finishing

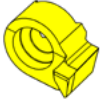

Page 378
Fine Finishing
.FB Geometry

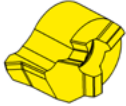
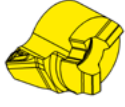
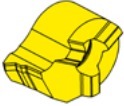
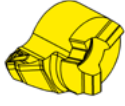

INSERTS	Face Grooving			
				
	Page 379-380 Face Grooving .472" / 12mm	Page 381-382 Face Grooving Full Radius, .472"/12mm	Page 383-384 Face Grooving .551" / 14mm	Page 385-386 Face Grooving Large Depth, .551"/14mm
				
	Page 387-388 Face Grooving Full Radius, .551"/14mm	Page 389 Face Groove Chamfering		
	Threading			
				
	Page 390 Threading, 60° Partial Profile	Page 391 Threading, Partial .GM Chipbreaker	Page 392 Threading, 60° Full Profile	Page 393 Threading, Full .GM Chipbreaker
				
	Page 394 Threading Trapezoidal			



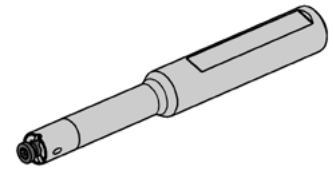
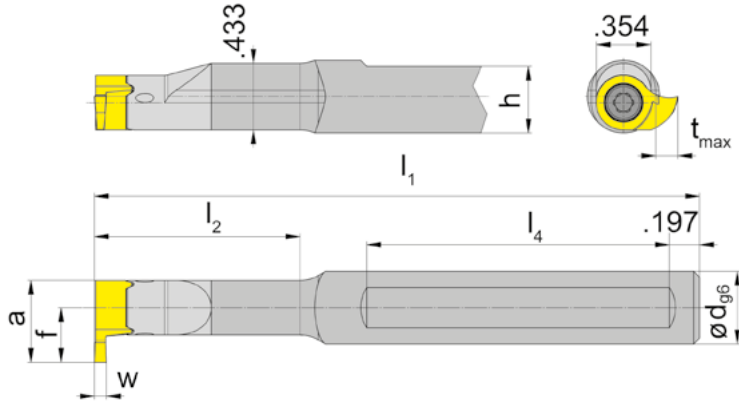
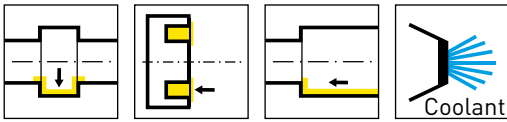

Picture = right hand insert shown

Part number	d	l ₁	l ₂	h	l ₄	HWS
BU114.ST05.00	.500	2.953	.748	.461	1.575	114090R • 114090L
BU114.ST06.00	.625	3.150	.748	.585	1.575	114090R • 114090L
BU114.0500.01	.500	3.937	1.339	.461	1.969	114090R • 114090L
BU114.0500.02	.500	4.331	1.772	.461	1.969	114090R • 114090L
BU114.0500.03	.500	5.118	2.520	.461	1.969	114090R • 114090L
BU114.0625.01	.625	3.937	1.339	.585	1.969	114090R • 114090L
BU114.0625.02	.625	4.331	1.772	.585	1.969	114090R • 114090L
BU114.0625.03	.625	5.118	2.520	.585	1.969	114090R • 114090L

Holders with ".ST" are steel shanks

For w, a, tmax and f dimensions, see insert pages

Dimensions in inch



Spare Parts

Toolholder	Clamping Screw	TORX PLUS® Wrench	Torque Value
BU114...	4.12T15EP	T15PQ	5 Nm



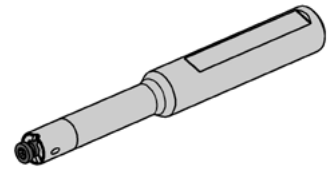
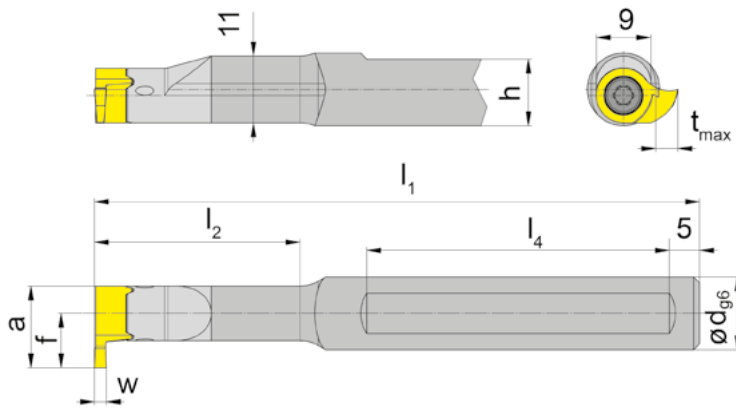
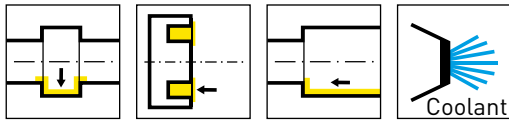

Picture = right hand insert shown

Part number	d	l ₁	l ₂	h	l ₄	HWS
B114.0012.00	12	75	19.5	11	40	114090R • 114090L
B114.0012.01	12	100	34	11	50	114090R • 114090L
B114.0012.02	12	110	45	11	50	114090R • 114090L
B114.0012.03	12	130	64	11	50	114090R • 114090L
B114.0016.00	16	80	19.5	15	40	114090R • 114090L
B114.0016.01	16	100	34	15	50	114090R • 114090L
B114.0016.02	16	110	45	15	50	114090R • 114090L
B114.0016.03	16	130	64	15	50	114090R • 114090L

For w, a, tmax and f dimensions, see insert pages

1 clamping flat

Dimensions in mm



Spare Parts

Toolholder	Clamping Screw	TORX PLUS® Wrench	Torque Value
B114...	4.12T15EP	T15PQ	5 Nm

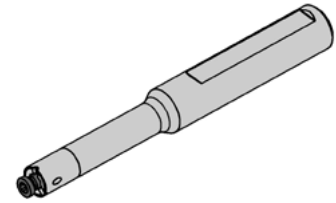
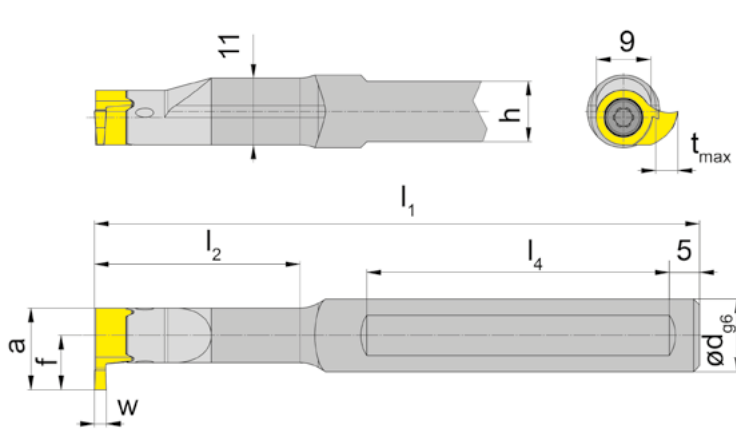
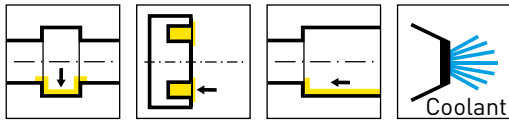

Picture = right hand insert shown

Part number	d	l ₁	l ₂	h	l ₄	HWS
B114.0012.2.00	12	75	19.5	11	40	114090R • 114090L
B114.0012.2.01	12	100	34	11	50	114090R • 114090L
B114.0012.2.02	12	110	45	11	50	114090R • 114090L
B114.0012.2.03	12	130	64	11	50	114090R • 114090L
B114.0016.2.00	16	80	19.5	14	40	114090R • 114090L
B114.0016.2.01	16	100	34	14	50	114090R • 114090L
B114.0016.2.02	16	110	45	14	50	114090R • 114090L
B114.0016.2.03	16	130	64	14	50	114090R • 114090L

For w, a, t_{max} and f dimensions, see insert pages

2 clamping flats

Dimensions in mm

Spare Parts

Toolholder	Clamping Screw	TORX PLUS® Wrench	Torque Value
B114...	4.12T15EP	T15PQ	5 Nm



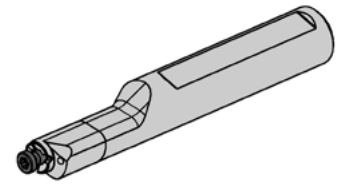
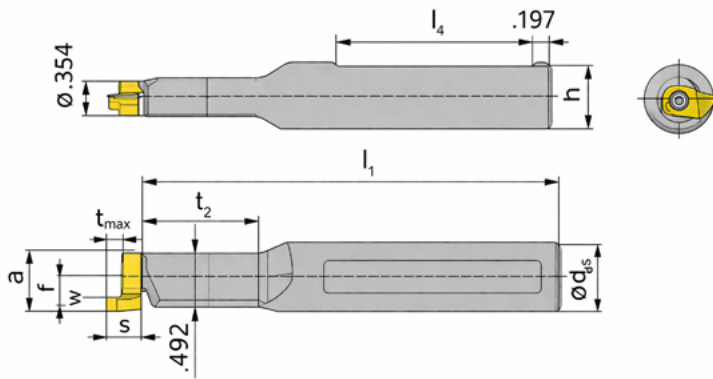
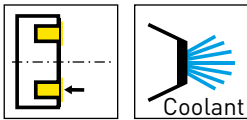

Picture = right hand insert shown

Part number	d	l ₁	l ₂	h	l ₄	HWS
RBAU114.0625.01	.625	4.252	1.457	.586	1.969	114090R • 114090L
RBAU114.0625.02	.625	4.646	1.890	.586	1.969	114090R • 114090L

For w, a, s, tmax and f dimensions, see insert pages

Dimensions in inch



Spare Parts

Toolholder	Clamping Screw	TORX PLUS® Wrench	Torque Value
RBAU114...	4.12T15EP	T15PQ	5 Nm

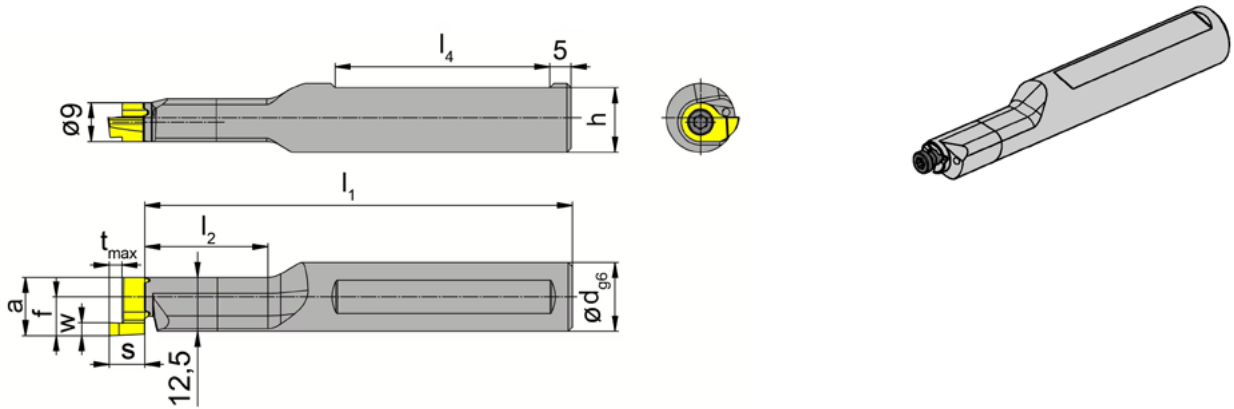
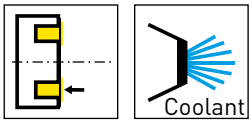

R = right hand version shown

L = left hand version

Part number	d	l_1	l_2	h	l_4	HWS
RBA114.0016.01	16	99.7	28.7	15	50	114090R • 114090L
RBA114.0016.02	16	109.7	39.7	15	50	114090R • 114090L
LBA114.0016.01	16	99.7	28.7	15	50	114090R • 114090L
LBA114.0016.02	16	109.7	39.7	15	50	114090R • 114090L

For w, a, s, tmax and f dimensions, see insert pages

Dimensions in mm

Spare Parts

Toolholder	Clamping Screw	TORX PLUS® Wrench	Torque Value
R/LBA114...	4.12T15EP	T15PQ	5 Nm



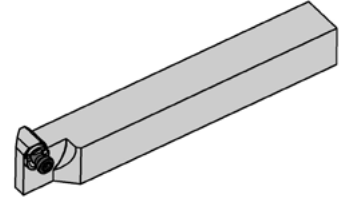
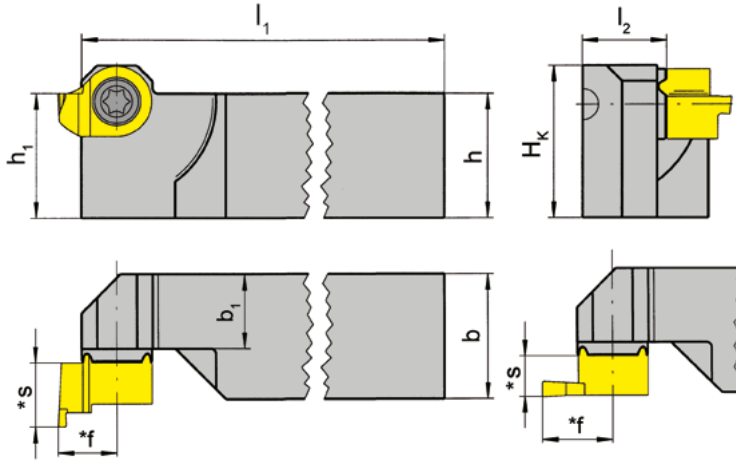
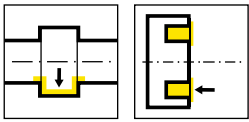

R = right hand version shown

L = left hand version

Part number	h	b	l ₁	l ₂	h ₁	b ₁	H _k	HWS
RHCU114.0500.01	.500	.500	3.937	.441	.500	.374	.642	114090R • 114090L
RHCU114.0625.01	.625	.625	4.921	.441	.625	.374	.768	114090R • 114090L
RHCU114.0750.01	.750	.750	4.921	.559	.750	.492	.894	114090R • 114090L
RHCU114.1000.01	1.000	1.000	5.906	.815	1.000	.728	1.142	114090R • 114090L
LHCU114.0500.01	.500	.500	3.937	.441	.500	.374	.642	114090R • 114090L
LHCU114.0625.01	.625	.625	4.921	.441	.625	.374	.768	114090R • 114090L
LHCU114.0750.01	.750	.750	4.921	.559	.750	.492	.894	114090R • 114090L
LHCU114.1000.01	1.000	1.000	5.906	.815	1.000	.728	1.142	114090R • 114090L

Right hand toolholders use left hand inserts. Left hand toolholders use right hand inserts. For face grooving, these holders are only compatible with R/L114.12__ inserts. For OD grooving, all inserts are compatible.

For s and f dimensions, see insert pages

Dimensions in inch



Spare Parts

Toolholder	Clamping Screw	TORX PLUS® Wrench	Torque Value
R/LHCU114...	4.12T15EP	T15PQ	5 Nm

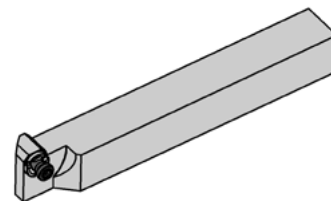
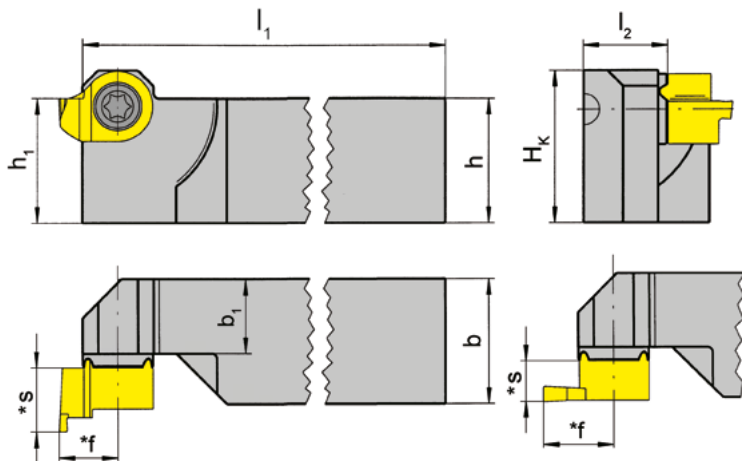
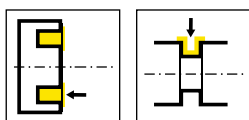

R = right hand version shown

L = left hand version

Part number	h	b	l ₁	l ₂	h ₁	b ₁	H _k	HWS
RHC114.1212.01	12	12	122	11.2	12	9.5	15.6	114090R • 114090L
RHC114.1616.01	16	16	122	11.2	16	9.5	19.6	114090R • 114090L
RHC114.2020.01	20	20	122	15.2	20	13.5	23.6	114090R • 114090L
RHC114.2525.01	25	25	147	20.2	25	18.5	28.6	114090R • 114090L
LHC114.1212.01	12	12	122	11.2	12	9.5	15.6	114090R • 114090L
LHC114.1616.01	16	16	122	11.2	16	9.5	19.6	114090R • 114090L
LHC114.2020.01	20	20	122	15.2	20	13.5	23.6	114090R • 114090L
LHC114.2525.01	25	25	147	20.2	25	18.5	28.6	114090R • 114090L

Right hand toolholders use left hand inserts. Left hand toolholders use right hand inserts. For face grooving, these holders are only compatible with R/L114.12__ inserts. For OD grooving, all inserts are compatible.

For s and f dimensions, see insert pages

Dimensions in mm

Spare Parts

Toolholder	Clamping Screw	TORX PLUS® Wrench	Torque Value
R/LHC114...	4.12T15EP	T15PQ	5 Nm



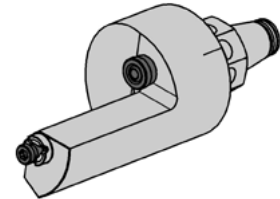
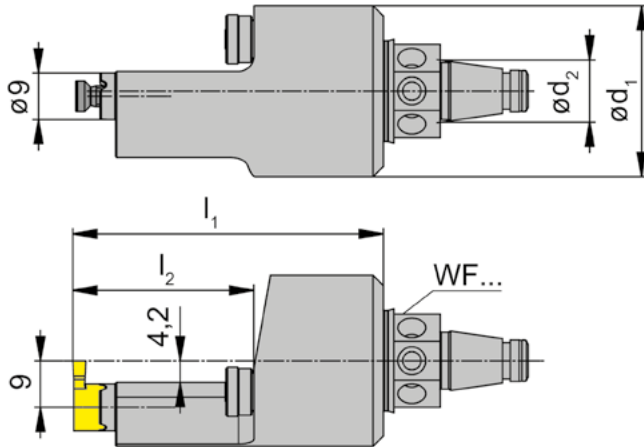

Picture = left hand insert shown

Part number	d_1	l_1	d_2	l_2	HWS	HMS
WFB.2H0.114	33	60	12	35	114090R • 114090L	WFB
WFB.3H0.114	50	80	20	32	114090R • 114090L	WFB

For more W&F holder options, see our catalog - W&F Modular Technology for Swiss Type Machines

Dimensions in mm



Spare Parts

Toolholder	Clamping Screw	Coolant spray nozzle	TORX PLUS® Wrench	Torque Value
WFB...	4.12T15EP	020.0806.3116	T15PQ	5 Nm

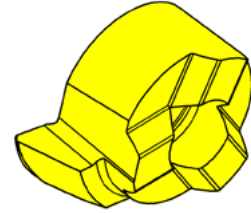
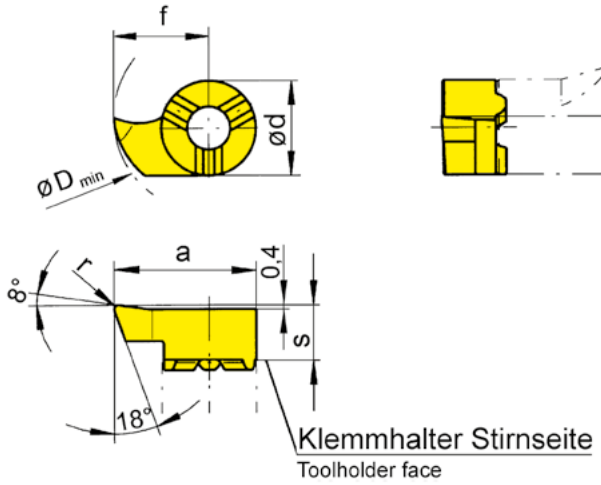
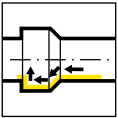

Coating grades

R = right hand version shown

L = left hand version

▲ In stock

Δ 2 weeks

Part number	s	f	a	r	d	D _{min}	HIS	EG55	IG35	TH35	TN35
R114.1890.02	5.3	8.7	13.2	0.2	9	13.8	114090R	▲	▲	▲	▲
L114.1890.02	5.3	8.7	13.2	0.2	9	13.8	114090L	▲	▲	▲	▲

Dimensions in mm

P	●	●	●	●
M	●	●	●	-
K	●	●	●	●
N	-	○	-	○
S	-	○	-	-
H	-	-	-	-



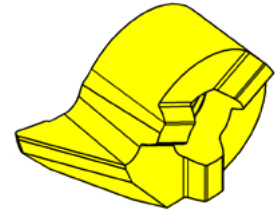
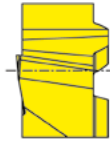
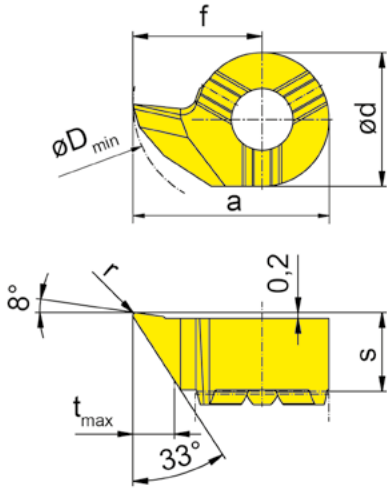
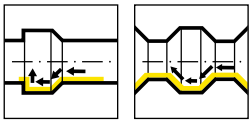

Coating grades

R = right hand version shown

L = left hand version

▲ In stock

Δ 2 weeks

Part number	s	f	a	r	d	t _{max}	D _{min}	HIS	EG55
R114.3387.02	5.3	8.7	13.2	0.2	9	2.8	13.8	114090R	▲
R114.3387.04	5.3	8.7	13.2	0.4	9	2.8	13.8	114090R	▲
L114.3387.02	5.3	8.7	13.2	0.2	9	2.8	13.8	114090L	▲
L114.3387.04	5.3	8.7	13.2	0.4	9	2.8	13.8	114090L	▲

Dimensions in mm

P	●
M	●
K	●
N	-
S	-
H	-

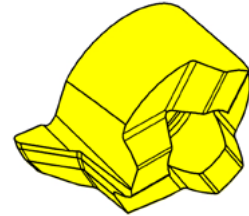
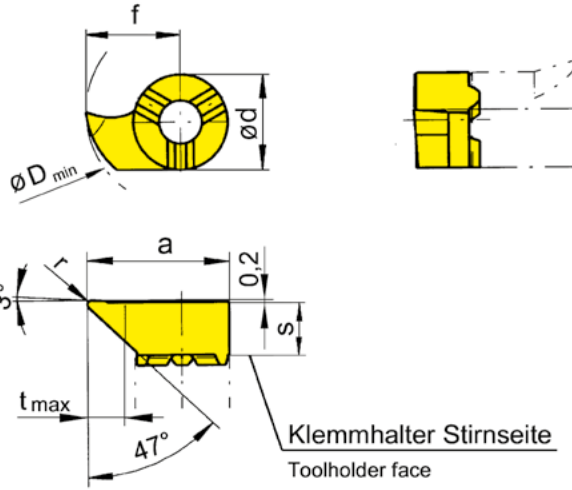
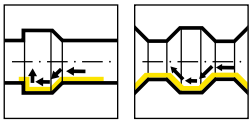

Coating grades

R = right hand version shown

L = left hand version

▲ In stock

Δ 2 weeks

Part number	s	f	a	r	d	t _{max}	D _{min}	HIS	EG55	IG35	TH35	TN35
R114.4787.02	5.3	8.7	13.2	0.2	9	3	13.8	114090R	▲	▲	▲	▲
R114.4787.04	5.3	8.7	13.2	0.4	9	3	13.8	114090R	▲	▲	▲	▲
R114.4710.02	5.3	11	15.5	0.2	9	5	16	114090R	▲	▲	▲	▲
L114.4787.02	5.3	8.7	13.2	0.2	9	3	13.8	114090L	▲	▲	▲	▲
L114.4787.04	5.3	8.7	13.2	0.4	9	3	13.8	114090L	▲	▲	▲	▲
L114.4710.02	5.3	11	15.5	0.2	9	5	16	114090L	▲	▲	▲	▲

Dimensions in mm

P	●	●	●	●
M	●	●	●	-
K	●	●	●	●
N	-	○	-	○
S	-	○	-	-
H	-	-	-	-



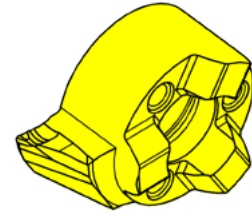
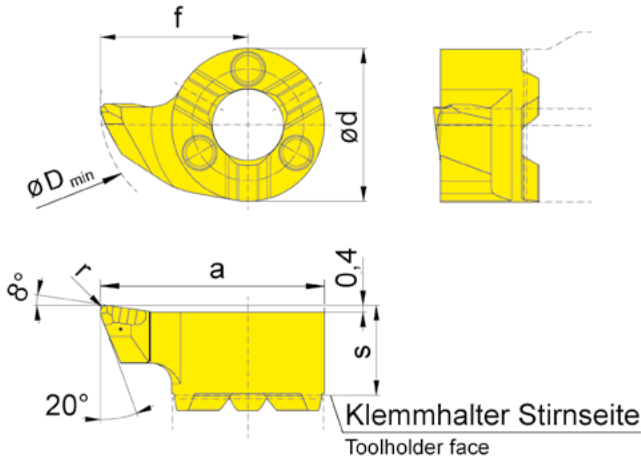
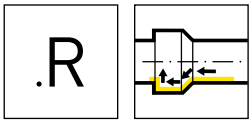

Coating grades

R = right hand version shown

L = left hand version

▲ In stock

△ 2 weeks

Part number	s	f	a	r	d	D _{min}	HIS	EG55	TH35
RS114.1890.R2	5.3	8.7	13.2	0.2	9	13.8	114090R	▲	▲
RS114.1890.R4	5.3	8.7	13.2	0.4	9	13.8	114090R	▲	▲
LS114.1890.R2	5.3	8.7	13.2	0.2	9	13.8	114090L	▲	▲
LS114.1890.R4	5.3	8.7	13.2	0.4	9	13.8	114090L	▲	▲

Dimensions in mm

P	●	●
M	●	●
K	●	●
N	-	-
S	-	-
H	-	-

Insert

S114 $\varnothing \geq 14$ mm

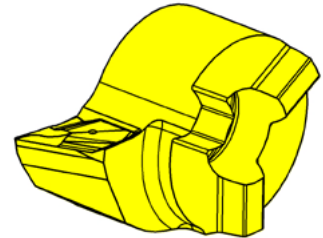
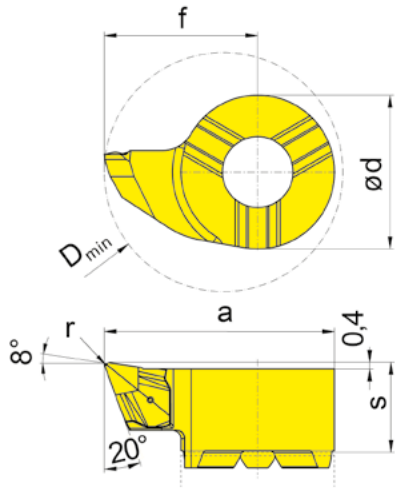
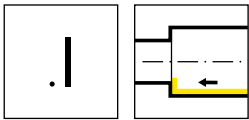

Coating grades

R = right hand version shown

▲ In stock

Δ 2 weeks

Part number	s	f	a	r	d	D _{min}	HIS	IG35	TH35
RS114.0820.I05	5.3	9	13.5	0.05	9	14	114090R	Δ	Δ
RS114.0820.I10	5.3	9	13.5	0.1	9	14	114090R	▲	▲
RS114.0820.I20	5.3	9	13.5	0.2	9	14	114090R	▲	▲
								P	● ●
								M	● ●
								K	● ●
								N	○ -
								S	○ -
								H	- -

Dimensions in mm



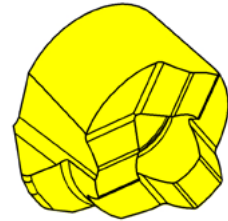
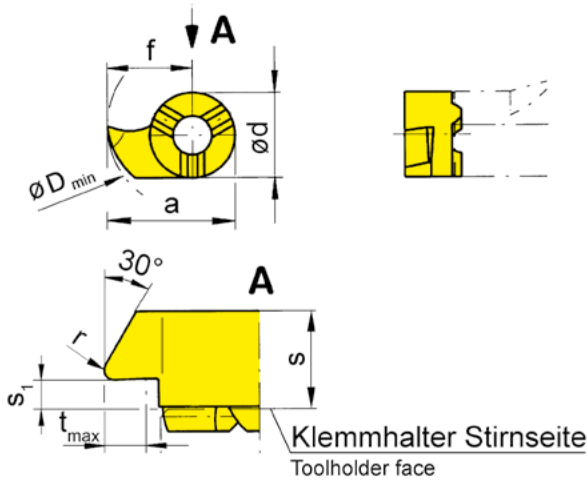
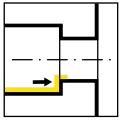

Coating grades

R = right hand version shown

L = left hand version

▲ In stock

Δ 2 weeks

Part number	s	f	r	s ₁	d	t _{max}	D _{min}	HIS	EG55	IG35	TH35	TN35
R114.3090.02	5.5	8.7	0.2	2.4	9	3.5	13.8	114090R	▲	▲	▲	▲
L114.3090.02	5.5	8.7	0.2	2.4	9	3.5	13.8	114090L	▲	▲	▲	▲

Dimensions in mm

P	●	●	●	●
M	●	●	●	-
K	●	●	●	●
N	-	○	-	○
S	-	○	-	-
H	-	-	-	-

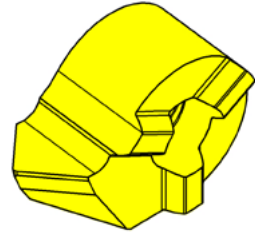
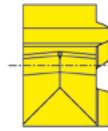
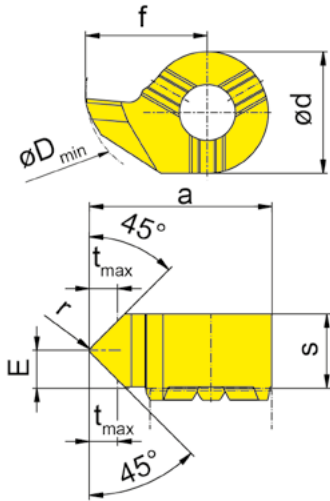
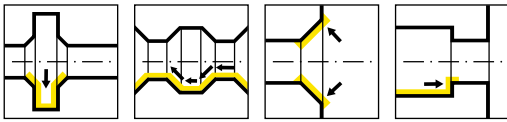

Coating grades

R = right hand version shown

L = left hand version

▲ In stock

Δ 2 weeks

Part number	E	s	f	a	r	d	t _{max}	D _{min}	HIS	EG55
R114.4545.02	2.8	5.5	9	13.5	0.2	9	2.1	14	114090R	▲
L114.4545.02	2.8	5.5	9	13.5	0.2	9	2.1	14	114090L	

Dimensions in mm

P	●
M	●
K	●
N	-
S	-
H	-



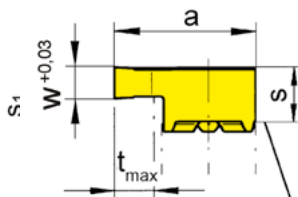
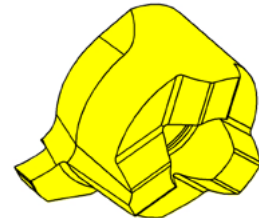
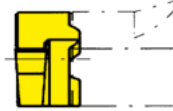
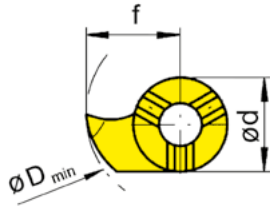
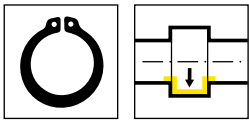

Klemmhalter Stirnseite
Toolholder face

Coating grades

R = right hand version shown

L = left hand version

▲ In stock

Δ 2 weeks

Part number	w	s	f	a	s ₁	d	t _{max}	D _{min}	HIS	MG12	IG35	TF45	TH35	TN35
RU114.0031.00	.031	.217	.354	.531	.209	.354	.047	.551	114090R		▲		▲	▲
RU114.0046.00	.046	.209	.354	.531	-	.354	.157	.551	114090R		▲	Δ	▲	▲
RU114.0062.00	.062	.209	.354	.531	-	.354	.157	.551	114090R		▲	Δ	▲	▲
RU114.0078.00	.078	.209	.354	.531	-	.354	.157	.551	114090R	Δ	▲		▲	▲
RU114.0094.00	.094	.209	.354	.531	-	.354	.157	.551	114090R	▲	▲	▲	▲	▲
RU114.0125.00	.125	.209	.354	.531	-	.354	.157	.551	114090R		▲		▲	▲
RU114.0056.00	.056	.209	.354	.531	-	.354	.157	.551	114090R		▲		▲	▲
RU114.0039.00	.039	.217	.354	.531	.209	.354	.047	.551	114090R		▲		▲	▲
LU114.0031.00	.031	.217	.354	.531	.209	.354	.047	.551	114090L		▲			▲
LU114.0046.00	.046	.209	.354	.531	-	.354	.157	.551	114090L		▲			▲
LU114.0062.00	.062	.209	.354	.531	-	.354	.157	.551	114090L	Δ	▲			▲
LU114.0078.00	.078	.209	.354	.531	-	.354	.157	.551	114090L	Δ	▲			▲
LU114.0094.00	.094	.209	.354	.531	-	.354	.157	.551	114090L		▲			▲
LU114.0125.00	.125	.209	.354	.531	-	.354	.157	.551	114090L		▲			▲
LU114.0056.00	.056	.209	.354	.531	-	.354	.157	.551	114090L		▲			▲

.031 and .039 widths are not face cutting and have limited depths of cut

Dimensions in inch



P	-	●	-	●	●
M	-	●	-	●	-
K	-	●	-	●	●
N	●	○	-	-	○
S	-	○	-	-	-
H	-	-	-	-	-

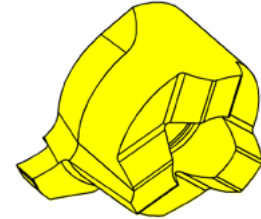
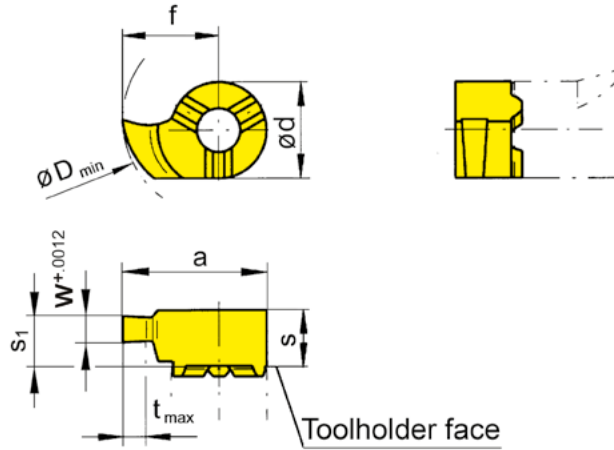
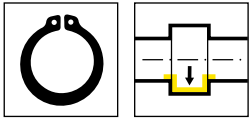

Coating grades

R = right hand version shown

L = left hand version

▲ In stock

△ 2 weeks

Part number	w	s	f	a	s ₁	d	t _{max}	D _{min}	HIS	EG55	TN35
R114.0070.00	0.74	5.5	9	13.5	5.3	9	1.2	14	114090R	▲	▲
R114.0080.00	0.84	5.5	9	13.5	5.3	9	1.3	14	114090R	▲	▲
R114.0090.00	0.94	5.5	9	13.5	5.3	9	1.5	14	114090R	▲	▲
L114.0070.00	0.74	5.5	9	13.5	5.3	9	1.2	14	114090L		▲
L114.0080.00	0.84	5.5	9	13.5	5.3	9	1.3	14	114090L	△	▲
L114.0090.00	0.94	5.5	9	13.5	5.3	9	1.5	14	114090L	▲	▲

Not face cutting, limited depth of cut

Dimensions in mm

	P	M	K	N	S	H
EG55	●	●	●	-	-	-
TN35	●	-	●	o	-	-



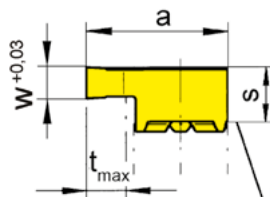
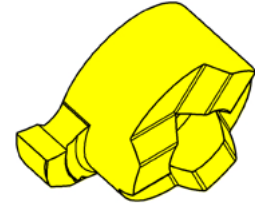
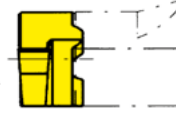
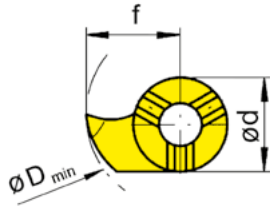
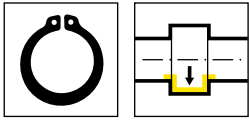

Klemmhalter Stirnseite
Toolholder face

Coating grades

R = right hand version shown

L = left hand version

▲ In stock

Δ 2 weeks

Part number	w	s	f	a	d	t _{max}	D _{min}	HIS	EG55	IG35	TH35	TN35
R114.0110.00	1.19	5.3	9	13.5	9	4	14	114090R	▲	▲	▲	▲
R114.0130.00	1.39	5.3	9	13.5	9	4	14	114090R	▲	▲	▲	▲
R114.0160.00	1.69	5.3	9	13.5	9	4	14	114090R	▲	▲	▲	▲
L114.0110.00	1.19	5.3	9	13.5	9	4	14	114090L	▲	▲	▲	▲
L114.0130.00	1.39	5.3	9	13.5	9	4	14	114090L	▲	▲	▲	▲
L114.0160.00	1.69	5.3	9	13.5	9	4	14	114090L	▲	▲	▲	▲

Dimensions in mm

P	●	●	●	●
M	●	●	●	-
K	●	●	●	●
N	-	○	-	○
S	-	○	-	-
H	-	-	-	-

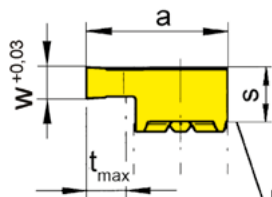
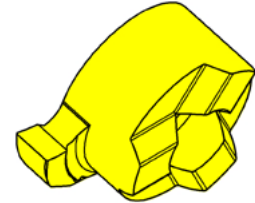
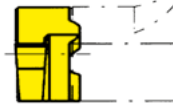
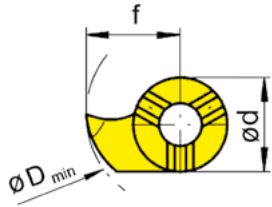
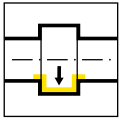

Klemmhalter Stirnseite
Toolholder face

Coating grades

R = right hand version shown

L = left hand version

▲ In stock

Δ 2 weeks

Part number	w	s	f	a	d	t _{max}	D _{min}	HIS	Coating grades			
									EG55	IG35	TH35	TN35
R114.0150.00	1.5	5.3	9	13.5	9	4	14	114090R	▲		▲	▲
R114.0200.00	2	5.3	9	13.5	9	4	14	114090R	▲		▲	▲
R114.0250.00	2.5	5.3	9	13.5	9	4	14	114090R	▲	▲	▲	▲
R114.0300.00	3	5.3	9	13.5	9	4	14	114090R	▲		▲	▲
L114.0150.00	1.5	5.3	9	13.5	9	4	14	114090L	▲		▲	▲
L114.0200.00	2	5.3	9	13.5	9	4	14	114090L	▲		▲	▲
L114.0250.00	2.5	5.3	9	13.5	9	4	14	114090L	▲		▲	▲
L114.0300.00	3	5.3	9	13.5	9	4	14	114090L	▲		▲	▲

Dimensions in mm

	P	M	K	N	S	H
EG55	●	●	●	●	●	●
IG35	●	●	●	-	-	-
TH35	●	●	●	●	●	●
TN35	●	●	●	●	●	●



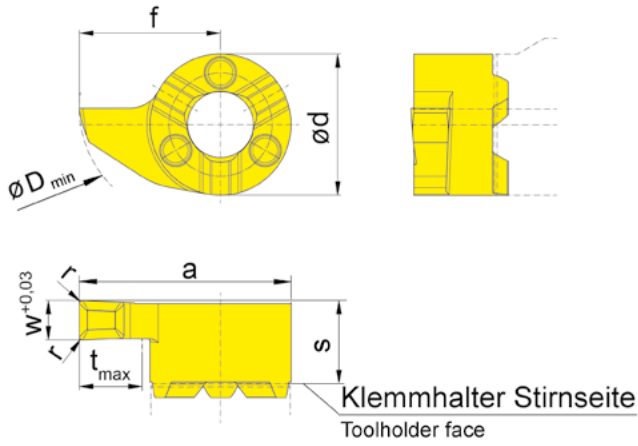
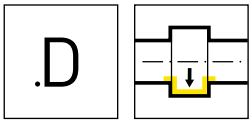

Coating grades

R = right hand version shown

L = left hand version

▲ In stock

Δ 2 weeks

Part number	w	s	f	a	r	d	t _{max}	D _{min}	HIS	Coating grades			
										EG55	TF45	TH35	TN35
RS114.0200.D2	2	5.3	9	13.5	0.2	9	4	14	114090R	▲	▲	▲	▲
RS114.0250.D2	2.5	5.3	9	13.5	0.2	9	4	14	114090R	▲	▲	▲	▲
RS114.0300.D2	3	5.3	9	13.5	0.2	9	4	14	114090R	▲	▲	▲	▲
LS114.0200.D2	2	5.3	9	13.5	0.2	9	4	14	114090L	▲	▲	▲	▲
LS114.0250.D2	2.5	5.3	9	13.5	0.2	9	4	14	114090L	▲	Δ	▲	▲
LS114.0300.D2	3	5.3	9	13.5	0.2	9	4	14	114090L	▲	▲	▲	▲

Dimensions in mm

P	●	-	●	●
M	●	-	●	-
K	●	-	●	●
N	-	-	-	○
S	-	-	-	-
H	-	-	-	-

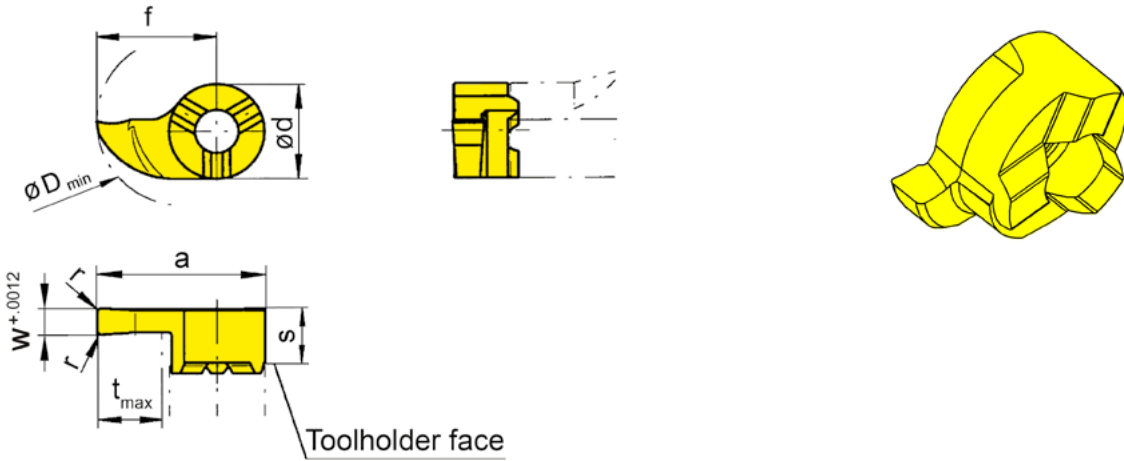
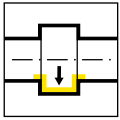

Coating grades

R = right hand version shown

L = left hand version

▲ In stock

Δ 2 weeks

Part number	w	s	f	a	r	d	t _{max}	D _{min}	HIS	MG12	IG35	TH35	TN35
RU114.0062.1.08	.062	.209	.445	.622	.008	.354	.256	.650	114090R		▲	▲	▲
RU114.0094.1.08	.094	.209	.445	.622	.008	.354	.256	.650	114090R	Δ	▲	▲	▲
RU114.0125.1.08	.125	.209	.445	.622	.008	.354	.256	.650	114090R	▲	▲	▲	▲
RU114.0078.1.08	.078	.209	.445	.622	.008	.354	.256	.650	114090R		▲	▲	▲
LU114.0062.1.08	.062	.209	.445	.622	.008	.354	.256	.650	114090L		▲	▲	▲
LU114.0094.1.08	.094	.209	.445	.622	.008	.354	.256	.650	114090L		▲	▲	▲
LU114.0125.1.08	.125	.209	.445	.622	.008	.354	.256	.650	114090L		▲	▲	▲

Dimensions in inch



P	-	●	●	●
M	-	●	●	-
K	-	●	●	●
N	●	○	-	○
S	-	○	-	-
H	-	-	-	-



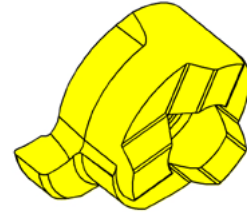
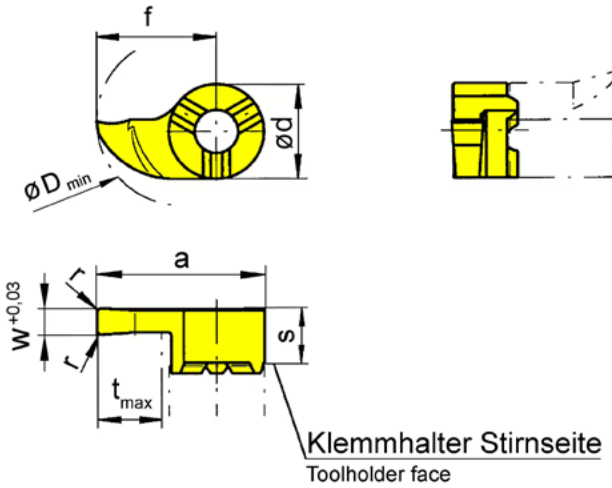
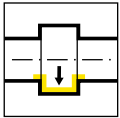

Coating grades

R = right hand version shown

L = left hand version

▲ In stock

Δ 2 weeks

Part number	w	s	f	a	r	d	t _{max}	D _{min}	HIS	EG55	IG35	TH35	TI25	TN35
R114.0150.1.02	1.5	5.3	11.3	15.8	0.2	9	6.5	16.5	114090R	▲	▲	▲		▲
R114.0200.1.02	2	5.3	11.3	15.8	0.2	9	6.5	16.5	114090R	▲		▲	▲	▲
R114.0250.1.02	2.5	5.3	11.3	15.8	0.2	9	6.5	16.5	114090R	▲	▲	▲		▲
R114.0300.1.02	3	5.3	11.3	15.8	0.2	9	6.5	16.5	114090R	▲	▲	▲		▲
R114.0400.1.02	4	5.3	11.3	15.8	0.2	9	6.5	16.5	114090R	Δ				▲
L114.0150.1.02	1.5	5.3	11.3	15.8	0.2	9	6.5	16.5	114090L	▲		▲		▲
L114.0200.1.02	2	5.3	11.3	15.8	0.2	9	6.5	16.5	114090L	▲		▲	Δ	▲
L114.0250.1.02	2.5	5.3	11.3	15.8	0.2	9	6.5	16.5	114090L	▲		▲		▲
L114.0300.1.02	3	5.3	11.3	15.8	0.2	9	6.5	16.5	114090L	▲		▲		▲
L114.0400.1.02	4	5.3	11.3	15.8	0.2	9	6.5	16.5	114090L	Δ				▲

Dimensions in mm

P	●	●	●	●	●
M	●	●	●	●	-
K	●	●	●	-	●
N	-	○	-	●	○
S	-	○	-	-	-
H	-	-	-	-	-

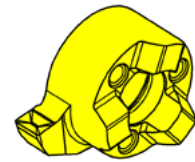
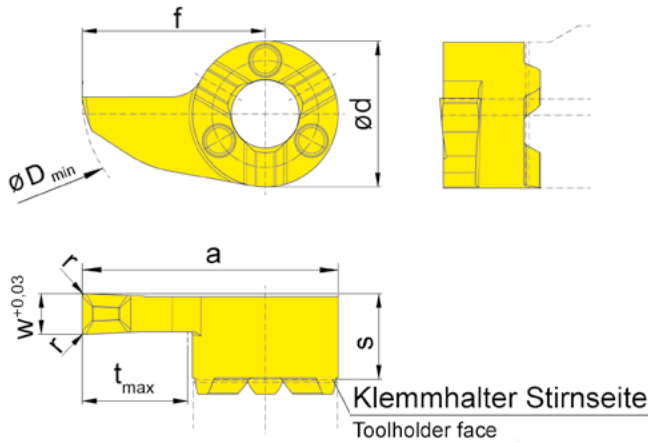
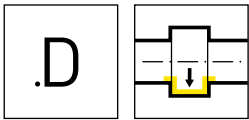

Coating grades

R = right hand version shown

L = left hand version

▲ In stock

Δ 2 weeks

Part number	w	s	f	a	r	d	t _{max}	D _{min}	HIS	EG55	TH35
RS114.0200.1.D2	2	5.3	11.3	15.8	0.2	9	6.5	16.5	114090R	▲	▲
RS114.0250.1.D2	2.5	5.3	11.3	15.8	0.2	9	6.5	16.5	114090R	▲	▲
RS114.0300.1.D2	3	5.3	11.3	15.8	0.2	9	6.5	16.5	114090R	▲	▲
LS114.0200.1.D2	2	5.3	11.3	15.8	0.2	9	6.5	16.5	114090L	▲	▲
LS114.0250.1.D2	2.5	5.3	11.3	15.8	0.2	9	6.5	16.5	114090L	Δ	▲
LS114.0300.1.D2	3	5.3	11.3	15.8	0.2	9	6.5	16.5	114090L	▲	▲

Dimensions in mm

P	●	●
M	●	●
K	●	●
N	-	-
S	-	-
H	-	-



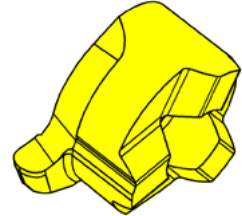
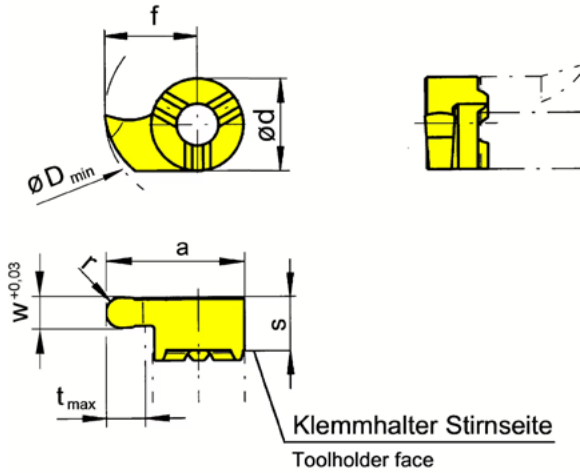
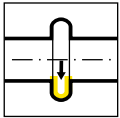

Coating grades

R = right hand version shown

L = left hand version

▲ In stock

Δ 2 weeks

Part number	w	s	f	a	r	d	t _{max}	D _{min}	HIS	IG35	TF45	TH35	TN35
RU114.0031.62	.062	.209	.354	.531	.032	.354	.157	.551	114090R	▲	Δ	▲	▲
RU114.0039.78	.078	.209	.354	.531	.039	.354	.157	.551	114090R	▲		▲	▲
RU114.0047.94	.094	.209	.354	.531	.047	.354	.157	.551	114090R	▲		▲	▲
RU114.0062.12	.125	.209	.354	.531	.063	.354	.157	.551	114090R	▲		▲	▲
LU114.0031.62	.062	.209	.354	.531	.032	.354	.157	.551	114090L	▲			▲
LU114.0039.78	.078	.209	.354	.531	.039	.354	.157	.551	114090L	▲			▲
LU114.0047.94	.094	.209	.354	.531	.047	.354	.157	.551	114090L	▲			▲
LU114.0062.12	.125	.209	.354	.531	.063	.354	.157	.551	114090L	▲			▲

Dimensions in inch



P	●	-	●	●
M	●	-	●	-
K	●	-	●	●
N	○	-	-	○
S	○	-	-	-
H	-	-	-	-



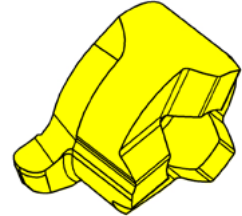
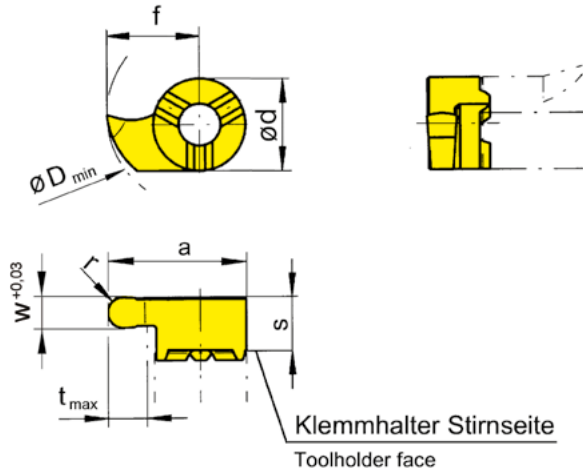
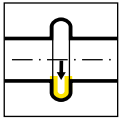

Coating grades

R = right hand version shown

L = left hand version

▲ In stock

△ 2 weeks

Part number	w	s	f	a	r	d	t _{max}	D _{min}	HIS	Coating grades				
										EG55	IG35	TH35	TI25	TN35
R114.0004.08	0.8	5.3	9	13.5	0.4	9	4	14	114090R				▲	
R114.0006.12	1.2	5.3	9	13.5	0.6	9	4	14	114090R	▲	▲	▲		▲
R114.0009.18	1.8	5.3	9	13.5	0.9	9	4	14	114090R	▲		▲		▲
R114.0010.20	2	5.3	9	13.5	1	9	4	14	114090R	▲	▲	▲		▲
R114.0011.22	2.2	5.3	9	13.5	1.1	9	4	14	114090R	▲	▲	▲		▲
R114.0015.30	3	5.3	9	13.5	1.5	9	4	14	114090R	▲		▲		▲
R114.0020.40	4	5.3	9	13.5	2	9	4	14	114090R	▲		▲		
L114.0004.08	0.8	5.3	9	13.5	0.4	9	4	14	114090L				▲	
L114.0006.12	1.2	5.3	9	13.5	0.6	9	4	14	114090L	▲		▲		▲
L114.0009.18	1.8	5.3	9	13.5	0.9	9	4	14	114090L	▲		▲		▲
L114.0010.20	2	5.3	9	13.5	1	9	4	14	114090L	▲		▲		▲
L114.0011.22	2.2	5.3	9	13.5	1.1	9	4	14	114090L	△		▲		▲
L114.0015.30	3	5.3	9	13.5	1.5	9	4	14	114090L	▲		▲		▲
L114.0020.40	4	5.3	9	13.5	2	9	4	14	114090L	△		△		

Dimensions in mm

P	●	●	●	●	●
M	●	●	●	●	-
K	●	●	●	-	●
N	-	○	-	●	○
S	-	○	-	-	-
H	-	-	-	-	-



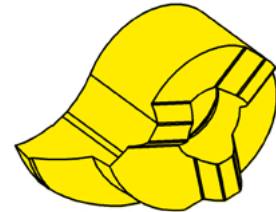
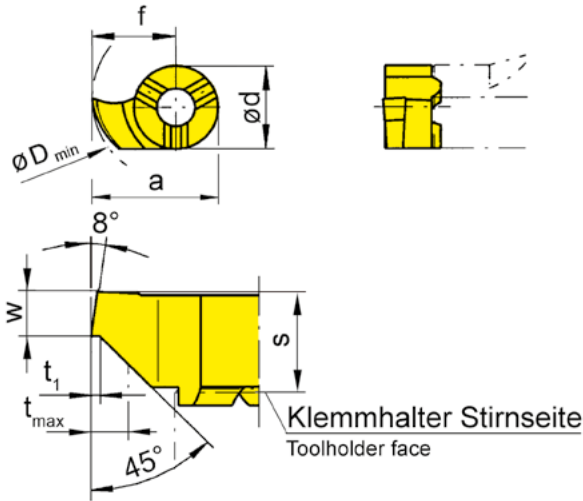
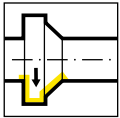

R = right hand version shown

L = left hand version

▲ In stock

Δ 2 weeks

Coating grades

Part number	w	s	f	a	d	t _{max}	t ₁	D _{min}	HIS	EG55	IG35	TI25
R114.0815.45	1.5	5.3	9	13.5	9	1.5	0.2	14	114090R	▲	▲	▲
L114.0815.45	1.5	5.3	9	13.5	9	1.5	0.2	14	114090L	▲	▲	▲

Dimensions in mm

P	●	●	●
M	●	●	●
K	●	●	-
N	-	○	●
S	-	○	-
H	-	-	-

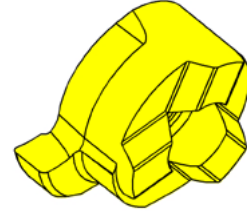
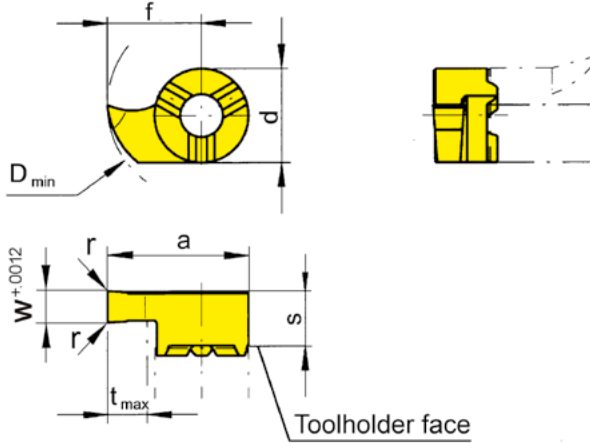
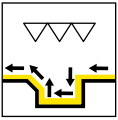

Coating grades

R = right hand version shown

L = left hand version

▲ In stock

△ 2 weeks

Part number	w	s	f	a	r	d	t _{max}	D _{min}	HIS	Coating grades					
										MG12	IG35	TF45	TH35	TI25	TN35
RU114.0031.08	.031	.209	.354	.531	.008	.354	.157	.551	114090R		▲	▲	▲		▲
RU114.0046.08	.046	.209	.354	.531	.008	.354	.157	.551	114090R		▲		▲		▲
RU114.0062.08	.062	.209	.354	.531	.008	.354	.157	.551	114090R		▲	▲	▲		▲
RU114.0078.08	.078	.209	.354	.531	.008	.354	.157	.551	114090R		▲		▲		▲
RU114.0094.08	.094	.209	.354	.531	.008	.354	.157	.551	114090R		▲	▲	▲		▲
RU114.0078.16	.078	.209	.354	.531	.016	.354	.157	.551	114090R		▲		▲		▲
RU114.0094.16	.094	.209	.354	.531	.016	.354	.157	.551	114090R	△	▲		▲		▲
RU114.0125.08	.125	.209	.354	.531	.008	.354	.157	.551	114090R	△	▲		▲	△	▲
RU114.0125.16	.125	.209	.354	.531	.016	.354	.157	.551	114090R		▲		▲		▲
RU114.0046.16	.046	.209	.354	.531	.016	.354	.157	.551	114090R		▲		▲		▲
RU114.0062.16	.062	.209	.354	.531	.016	.354	.157	.551	114090R		▲		▲		▲
LU114.0031.08	.031	.209	.354	.531	.008	.354	.157	.551	114090L		▲				▲
LU114.0046.08	.046	.209	.354	.531	.008	.354	.157	.551	114090L		▲				▲
LU114.0062.08	.062	.209	.354	.531	.008	.354	.157	.551	114090L		▲				▲
LU114.0078.08	.078	.209	.354	.531	.008	.354	.157	.551	114090L		▲				▲
LU114.0094.08	.094	.209	.354	.531	.008	.354	.157	.551	114090L		▲				▲
LU114.0078.16	.078	.209	.354	.531	.016	.354	.157	.551	114090L		▲				▲
LU114.0094.16	.094	.209	.354	.531	.016	.354	.157	.551	114090L		▲				▲
LU114.0125.08	.125	.209	.354	.531	.008	.354	.157	.551	114090R		▲				▲
LU114.0125.16	.125	.209	.354	.531	.016	.354	.157	.551	114090L						△

These inserts are optimized for finishing passes

Dimensions in inch



P	-	●	-	●	●	●
M	-	●	-	●	●	-
K	-	●	-	●	-	●
N	●	○	-	-	●	○
S	-	○	-	-	-	-
H	-	-	-	-	-	-



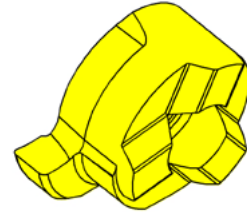
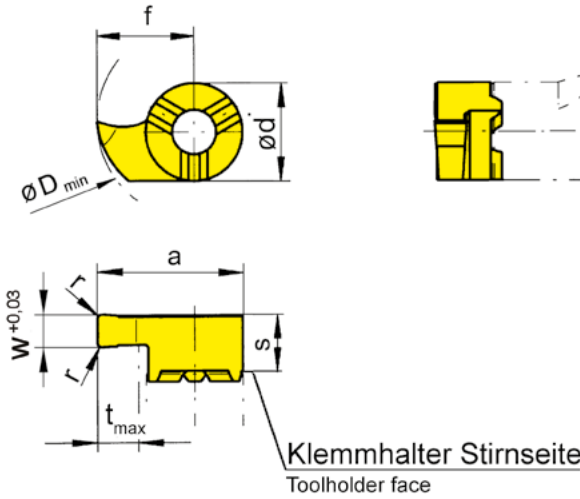
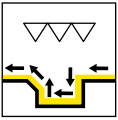

R = right hand version shown

L = left hand version

▲ In stock

Δ 2 weeks

Coating grades

Part number	w	s	f	a	r	d	t _{max}	D _{min}	HIS	EG55	IG35	TH35	TI25	TN35
R114.0200.02	2	5.3	9	13.5	0.2	9	4	14	114090R	▲	▲	▲	▲	▲
L114.0200.02	2	5.3	9	13.5	0.2	9	4	14	114090L	▲	▲	▲	▲	▲

These inserts are optimized for finishing passes

Dimensions in mm

P	●	●	●	●	●
M	●	●	●	●	-
K	●	●	●	-	●
N	-	○	-	●	○
S	-	○	-	-	-
H	-	-	-	-	-

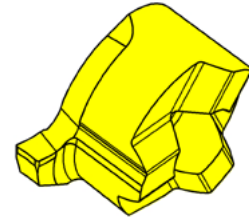
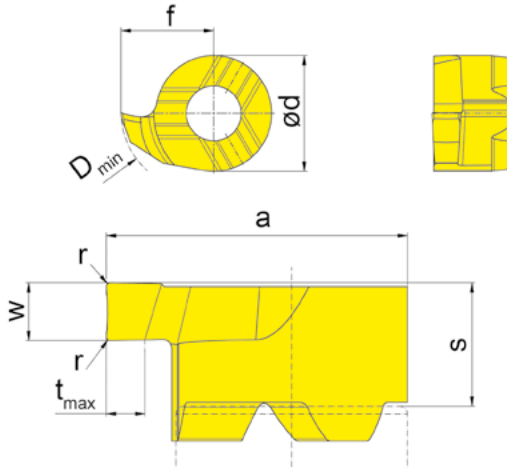
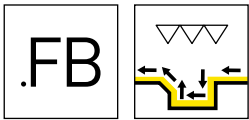

Coating grades

R = right hand version shown

L = left hand version

▲ In stock

Δ 2 weeks

Part number	w	s	f	a	r	d	t _{max}	D _{min}	HIS	EG35
R114.FB10.01	1	5.3	9	13.5	0.1	9	4	14	114090R	▲
R114.FB15.01	1.5	5.3	9	13.5	0.1	9	4	14	114090R	▲
L114.FB10.01	1	5.3	9	13.5	0.1	9	4	14	114090L	▲
L114.FB15.01	1.5	5.3	9	13.5	0.1	9	4	14	114090L	▲

These inserts feature an optimized geometry that produces a fine surface finish

Dimensions in mm

P	●
M	●
K	●
N	○
S	-
H	-

Smallest possible width of groove calculation, w_x

Example insert: R114.FB10.01

$$w_x = 2 \times \text{Width of insert (w)} - 2 \times \text{Insert corner radius (r)}$$

$$w_x = 2 \times 1 \text{ mm} - 2 \times 0.1 \text{ mm}$$

$$w_x = 1.8 \text{ mm}$$

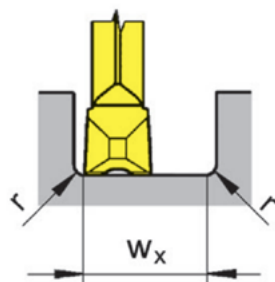

Operation order

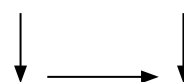

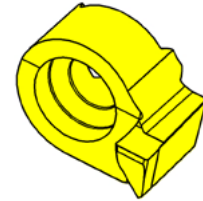
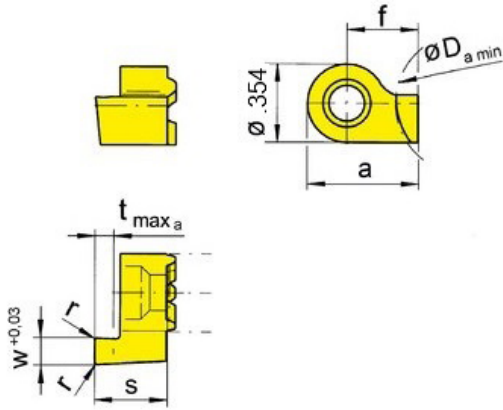
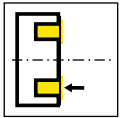

Coating grades

R = right hand version shown

L = left hand version

▲ In stock

Δ 2 weeks

Part number	w	s	f	a	r	t _{max a}	D _{a min}	HIS	IG35	TH35	TN35
RU114.1225.00	.125	.327	.295	.472	.008	.118	.472	114090R	▲	▲	▲
RU114.1246.00	.046	.327	.295	.472	-	.071	.472	114090R	▲	▲	▲
RU114.1262.00	.062	.327	.295	.472	.008	.098	.472	114090R	▲	▲	▲
RU114.1278.00	.078	.327	.295	.472	.008	.118	.472	114090R	▲	▲	▲
RU114.1294.00	.094	.327	.295	.472	.008	.118	.472	114090R	▲	▲	▲
LU114.1225.00	.125	.327	.295	.472	.008	.118	.472	114090L	▲		▲
LU114.1246.00	.046	.327	.295	.472	-	.071	.472	114090L	▲		▲
LU114.1262.00	.062	.327	.295	.472	.008	.098	.472	114090L	▲		▲
LU114.1278.00	.078	.327	.295	.472	.008	.118	.472	114090L	▲		▲
LU114.1294.00	.094	.327	.295	.472	.008	.118	.472	114090L	▲		▲

Inserts ending in ".00" have sharp corners with no radius

Dimensions in inch



P	●	●	●
M	●	●	-
K	●	●	●
N	○	-	○
S	○	-	-
H	-	-	-

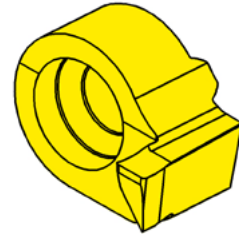
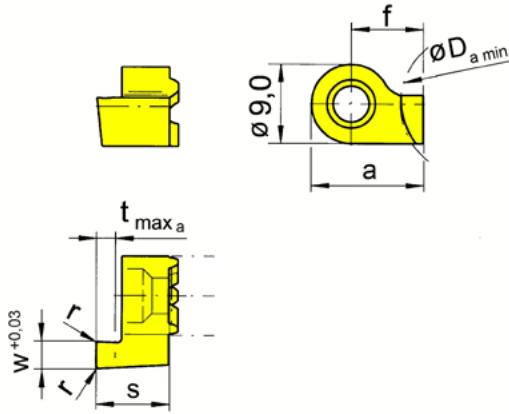
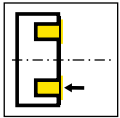

Coating grades

R = right hand version shown

L = left hand version

▲ In stock

Δ 2 weeks

Part number	w	s	f	a	r	t _{max a}	D _{a min}	HIS	EG55	IG35	TN35
R114.1205.00	0.5	8.3	7.5	12	-	1	12	114090R	Δ		▲
R114.1210.00	1	8.3	7.5	12	-	1.5	12	114090R	▲	▲	▲
R114.1215.00	1.5	8.3	7.5	12	0.2	2.5	12	114090R	▲		▲
R114.1220.00	2	8.3	7.5	12	0.2	3	12	114090R	▲	▲	▲
R114.1225.00	2.5	8.3	7.5	12	0.2	3	12	114090R	▲		▲
R114.1230.00	3	8.3	7.5	12	0.2	3	12	114090R	▲		▲
R114.1220.5.00	2	10.8	7.5	12	0.2	5	12	114090R	▲	▲	▲
R114.1225.5.00	2.5	10.8	7.5	12	0.2	5	12	114090R	▲		▲
R114.1230.6.00	3	11.8	7.5	12	0.2	6	12	114090R	▲	▲	▲
L114.1205.00	0.5	8.3	7.5	12	-	1	12	114090L	Δ	▲	▲
L114.1210.00	1	8.3	7.5	12	-	1.5	12	114090L	▲	▲	▲
L114.1215.00	1.5	8.3	7.5	12	0.2	2.5	12	114090L	▲	▲	▲
L114.1220.00	2	8.3	7.5	12	0.2	3	12	114090L	▲	▲	▲
L114.1225.00	2.5	8.3	7.5	12	0.2	3	12	114090L	▲	▲	▲
L114.1230.00	3	8.3	7.5	12	0.2	3	12	114090L	▲	▲	▲
L114.1220.5.00	2	10.8	7.5	12	0.2	5	12	114090L	▲	▲	▲
L114.1225.5.00	2.5	10.8	7.5	12	0.2	5	12	114090L	▲	▲	▲
L114.1230.6.00	3	11.8	7.5	12	0.2	6	12	114090L	▲	▲	▲

R = rotation anti-clockwise. When using this face grooving insert in a B114 holder, l1 and l2 will be enlarged by 3.0, 5.5, or 6.5 mm.

Machining behind center line

Dimensions in mm

P	●	●	●
M	●	●	-
K	●	●	●
N	-	○	○
S	-	○	-
H	-	-	-



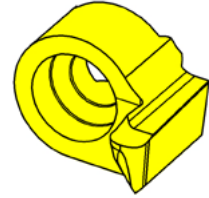
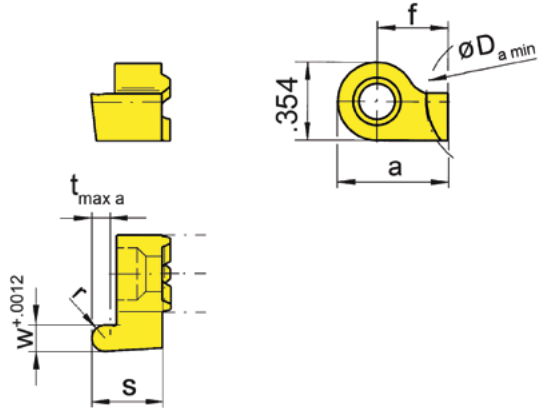
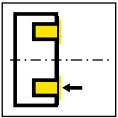

Coating grades

R = right hand version shown

L = left hand version

▲ In stock

Δ 2 weeks

Part number	w	s	f	a	r	t _{max a}	D _{a min}	HIS	IG35	TH35	TN35
RU114.1223.46	.046	.327	.295	.472	.023	.059	.472	114090R	▲	▲	▲
RU114.1231.62	.062	.327	.295	.472	.032	.098	.472	114090R	▲	▲	▲
RU114.1239.78	.078	.327	.295	.472	.039	.118	.472	114090R	▲	▲	▲
RU114.1247.94	.094	.327	.295	.472	.047	.118	.472	114090R	▲	▲	▲
RU114.1262.12	.125	.327	.295	.472	.063	.118	.472	114090R	▲	▲	▲
LU114.1223.46	.046	.327	.295	.472	.023	.059	.472	114090L	▲		▲
LU114.1231.62	.062	.327	.295	.472	.032	.098	.472	114090L	▲		▲
LU114.1239.78	.078	.327	.295	.472	.039	.118	.472	114090L	▲		▲
LU114.1247.94	.094	.327	.295	.472	.047	.118	.472	114090L	▲		▲
LU114.1262.12	.125	.327	.295	.472	.063	.118	.472	114090L	▲		▲

Dimensions in inch



P	●	●	●
M	●	●	-
K	●	●	●
N	○	-	○
S	○	-	-
H	-	-	-

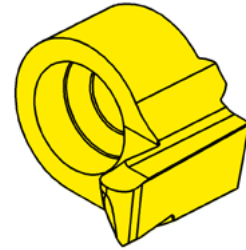
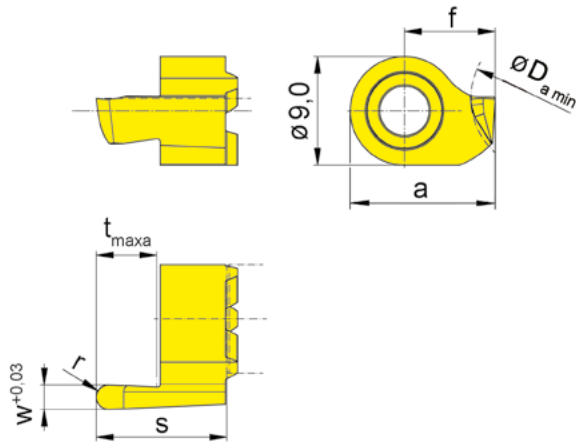
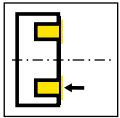

Coating grades

R = right hand version shown

L = left hand version

▲ In stock

△ 2 weeks

Part number	w	s	f	a	r	t _{max a}	D _{a min}	HIS	Coating grades			
									EG55	IG35	TN35	
R114.1220.5.10	2	10.8	7.5	12	1	5	12	114090R	▲	▲	▲	
R114.1225.5.12	2.5	10.8	7.5	12	1.25	5	12	114090R	▲	▲	▲	
R114.1230.6.15	3	11.8	7.5	12	1.5	6	12	114090R	▲	▲	▲	
L114.1220.5.10	2	10.8	7.5	12	1	5	12	114090L	▲	▲	▲	
L114.1225.5.12	2.5	10.8	7.5	12	1.25	5	12	114090L	▲	▲	▲	
L114.1230.6.15	3	11.8	7.5	12	1.5	6	12	114090L	▲	▲	▲	
									P	●	●	●
									M	●	●	-
									K	●	●	●
									N	-	o	o
									S	-	o	-
									H	-	-	-

R = rotation anti-clockwise. When using this face grooving insert on a B114 holder, l1 and l2 will be enlarged by 5.5 mm or 6.5 mm.

Full radius machining behind center line

Dimensions in mm



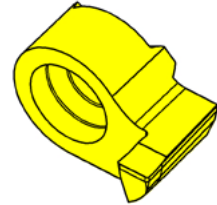
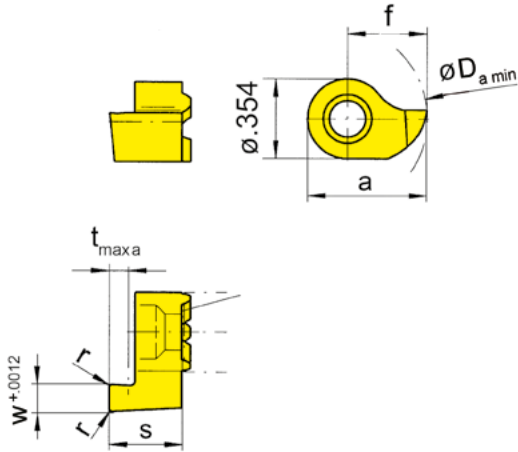
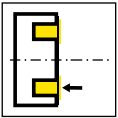

Coating grades

R = right hand version shown

L = left hand version

▲ In stock

Δ 2 weeks

Part number	w	s	f	a	r	$t_{\max a}$	$D_{a \min}$	HIS	IG35	TH35	TN35
RU114.1425.00	.125	.327	.354	.531	.008	.118	.551	114090R	▲	▲	▲
RU114.1446.00	.046	.327	.354	.531	-	.059	.551	114090R	▲	▲	▲
RU114.1462.00	.062	.327	.354	.531	.008	.098	.551	114090R	▲	▲	▲
RU114.1478.00	.078	.327	.354	.531	.008	.118	.551	114090R	▲	▲	▲
RU114.1494.00	.094	.327	.354	.531	.008	.118	.551	114090R	▲	▲	▲
LU114.1425.00	.125	.327	.354	.531	.008	.118	.551	114090L	▲		▲
LU114.1446.00	.046	.327	.354	.531	-	.059	.551	114090L	▲		▲
LU114.1462.00	.062	.327	.354	.531	.008	.098	.551	114090L	▲		▲
LU114.1478.00	.078	.327	.354	.531	.008	.118	.551	114090L	▲		▲
LU114.1494.00	.094	.327	.354	.531	.008	.118	.551	114090L	▲		▲

Inserts ending in ".00" have sharp corners with no radius

Dimensions in inch



P	●	●	●
M	●	●	-
K	●	●	●
N	○	-	○
S	○	-	-
H	-	-	-

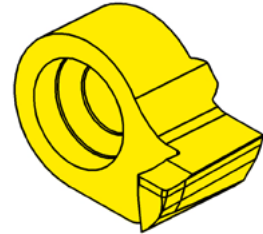
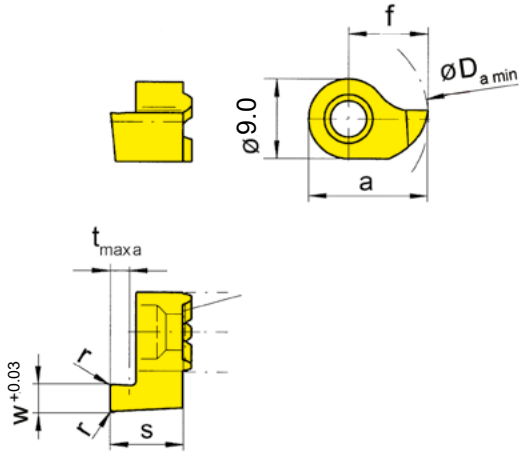
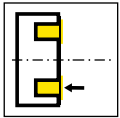

Coating grades

R = right hand version shown

L = left hand version

▲ In stock

Δ 2 weeks

Part number	w	s	f	a	r	t _{max a}	D _{a min}	HIS	Coating grades		
									EG55	IG35	TN35
R114.1410.00	1	8.3	9	13.5	-	1.5	14	114090R	▲	▲	▲
R114.1415.00	1.5	8.3	9	13.5	0.2	2.5	14	114090R	▲	▲	▲
R114.1420.00	2	8.3	9	13.5	0.2	3	14	114090R	▲	▲	▲
R114.1425.00	2.5	8.3	9	13.5	0.2	3	14	114090R	▲	▲	▲
R114.1430.00	3	8.3	9	13.5	0.2	3	14	114090R	▲	▲	▲
R114.1420.5.00	2	10.8	9	13.5	0.2	5	14	114090R	▲	▲	▲
R114.1425.5.00	2.5	10.8	9	13.5	0.2	5	14	114090R	▲	▲	▲
R114.1430.6.00	3	11.8	9	13.5	0.2	6	14	114090R	▲	▲	▲
L114.1410.00	1	8.3	9	13.5	-	1.5	14	114090L	▲	▲	▲
L114.1415.00	1.5	8.3	9	13.5	0.2	2.5	14	114090L	▲	▲	▲
L114.1420.00	2	8.3	9	13.5	0.2	3	14	114090L	▲	▲	▲
L114.1425.00	2.5	8.3	9	13.5	0.2	3	14	114090L	▲	▲	▲
L114.1430.00	3	8.3	9	13.5	0.2	3	14	114090L	▲	▲	▲
L114.1420.5.00	2	10.8	9	13.5	0.2	5	14	114090L	▲	▲	▲
L114.1425.5.00	2.5	10.8	9	13.5	0.2	5	14	114090L	▲	▲	▲
L114.1430.6.00	3	11.8	9	13.5	0.2	6	14	114090L	▲	▲	▲
P	●	●	●								
M	●	●	●								
K	●	●	●								
N	-	○	○								
S	-	○	-								
H	-	-	-								

R = rotation clockwise. When using this face grooving insert in a B114 holder, the l1 and l2 will be enlarged by 3.0, 5.5, or 6.5 mm.

Machining in-front of center line

Dimensions in mm



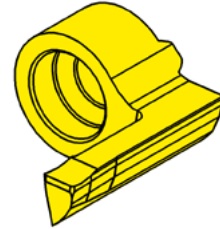
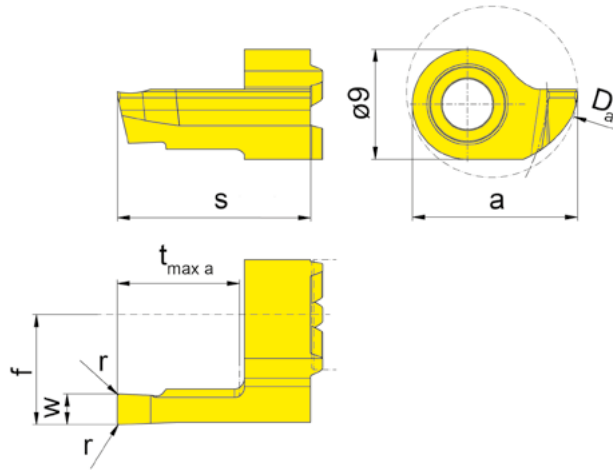
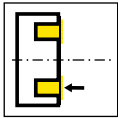

Coating grades

R = right hand version shown

L = left hand version

▲ In stock

Δ 2 weeks

Part number	w	s	f	a	r	t _{max a}	D _{a min}	D _{a max}	HIS	EG55
R114.1420.10.00	2	15.9	9	13.5	0.2	10	14	34	114090R	▲
R114.1425.10.00	2.5	15.9	9	13.5	0.2	10	14	35	114090R	▲
R114.1430.10.00	3	15.9	9	13.5	0.2	10	14	36	114090R	▲

R = rotation clockwise. When using this face grooving insert in a B114 holder, the size of l1 and l2 will be enlarged by 3.0, 5.5, 6.5, or 10.6 mm.

Machining in-front of center line

Dimensions in mm

P	●
M	●
K	●
N	-
S	-
H	-

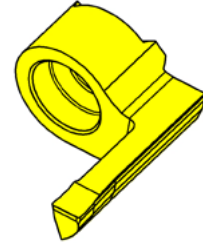
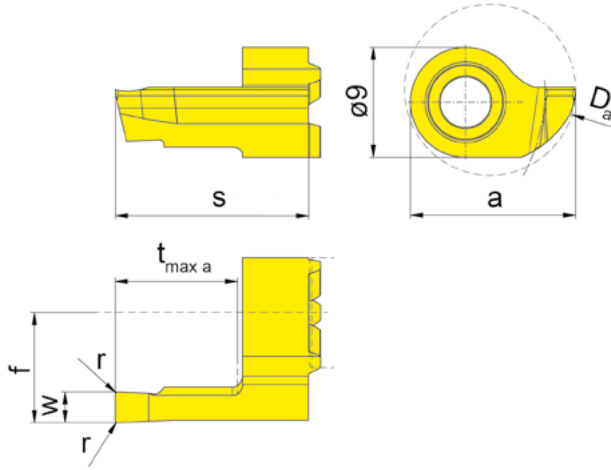
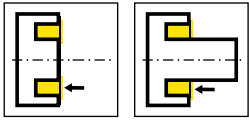

Coating grades

R = right hand version shown

L = left hand version

▲ In stock

Δ 2 weeks

Part number	w	s	f	a	r	t _{max a}	D _{a max}	HIS	EG35
R114.1420.10.00.L	2	15.9	7.5	12	0.2	10	14	114090R	▲
R114.1425.10.00.L	2.5	15.9	7.5	12	0.2	10	14	114090R	▲
R114.1430.10.00.L	3	15.9	7.5	12	0.2	10	14	114090R	▲

R = rotation clockwise. When using this face grooving insert in a B114 holder, the size of l1 and l2 will be enlarged by 3.0, 5.5, 6.5, or 10.6 mm.

These inserts feature a sweep towards centerline

Dimensions in mm

P	●
M	●
K	●
N	○
S	-
H	-



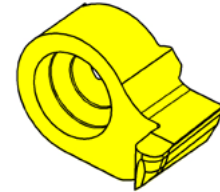
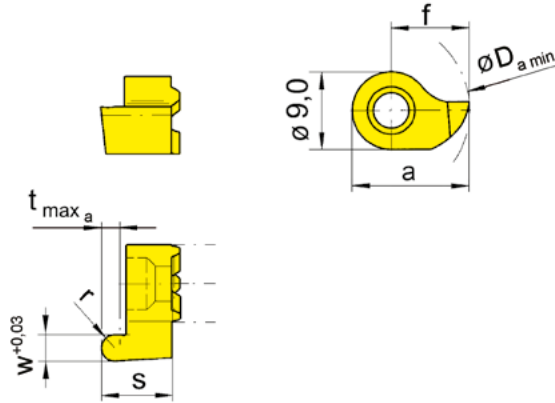
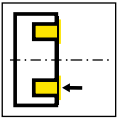

Coating grades

R = right hand version shown

L = left hand version

▲ In stock

Δ 2 weeks

Part number	w	s	f	a	r	t _{max a}	D _{a min}	HIS	IG35	TH35	TN35	
RU114.1423.46	.046	.327	.354	.531	.023	.059	.551	114090R	▲	▲	▲	
RU114.1431.62	.062	.327	.354	.531	.031	.098	.551	114090R	▲	▲	▲	
RU114.1439.78	.078	.327	.354	.531	.039	.118	.551	114090R	▲	▲	▲	
RU114.1447.94	.094	.327	.354	.531	.047	.118	.551	114090R	▲	▲	▲	
RU114.1462.12	.125	.327	.354	.531	.063	.118	.551	114090R	▲	▲	▲	
LU114.1431.62	.062	.327	.354	.531	.031	.098	.551	114090L	▲		▲	
LU114.1439.78	.078	.327	.354	.531	.039	.118	.551	114090L	▲		▲	
LU114.1447.94	.094	.327	.354	.531	.047	.118	.551	114090L	▲		▲	
LU114.1462.12	.125	.327	.354	.531	.063	.118	.551	114090L	▲		▲	
Dimensions in inch									P	●	●	●
									M	●	●	-
									K	●	●	●
									N	○	-	○
									S	○	-	-
									H	-	-	-



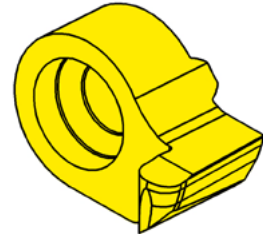
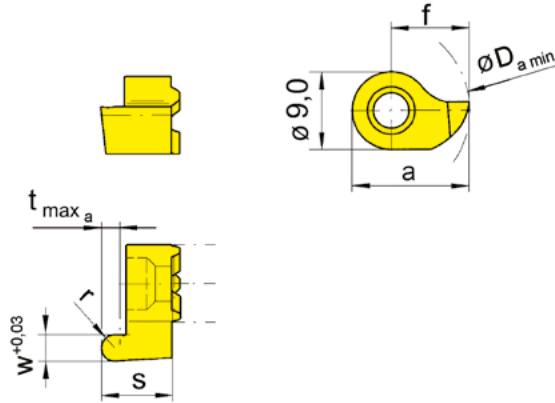
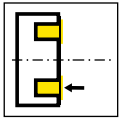

Coating grades

R = right hand version shown

L = left hand version

▲ In stock

△ 2 weeks

Part number	w	s	f	a	r	t _{max a}	D _{a min}	HIS	EG55	IG35	TN35
R114.1410.05	1	8.3	9	13.5	0.5	1.5	14	114090R	▲	▲	▲
R114.1416.08	1.6	8.3	9	13.5	0.8	2.5	14	114090R	▲		▲
R114.1420.10	2	8.3	9	13.5	1	3	14	114090R	▲	▲	▲
R114.1425.12	2.5	8.3	9	13.5	1.25	3	14	114090R	▲		▲
R114.1430.15	3	8.3	9	13.5	1.5	3	14	114090R	▲		▲
R114.1420.5.10	2	8.3	9	13.5	1	5	14	114090R	▲		
R114.1425.5.12	2.5	8.3	9	13.5	1.25	5	14	114090R	▲		
R114.1430.6.15	3	8.3	9	13.5	1.5	6	14	114090R	▲		
L114.1410.05	1	8.3	9	13.5	0.5	1.5	14	114090L	▲	▲	▲
L114.1416.08	1.6	8.3	9	13.5	0.8	2.5	14	114090L	▲		▲
L114.1420.10	2	8.3	9	13.5	1	3	14	114090L	▲		▲
L114.1425.12	2.5	8.3	9	13.5	1.25	3	14	114090L	▲		▲
L114.1430.15	3	8.3	9	13.5	1.5	3	14	114090L	▲		▲
L114.1420.5.10	2	8.3	9	13.5	1	5	14	114090L	△		
L114.1425.5.12	2.5	8.3	9	13.5	1.25	5	14	114090L	△		
L114.1430.6.15	3	8.3	9	13.5	1.5	6	14	114090L	△		
P	●	●	●								
M	●	●	●								
K	●	●	●								
N	-	○	○								
S	-	○	-								
H	-	-	-								

R = rotation clockwise. When using this insert on a B114 holder, l1 and l2 will be enlarged by 3 mm.

Full radius machining in-front of center line

Dimensions in mm



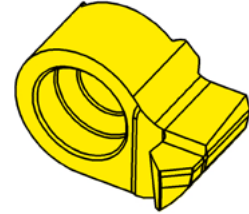
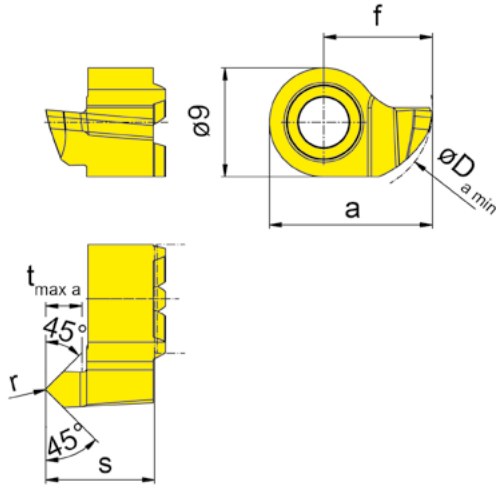
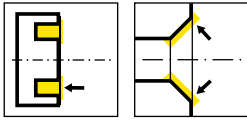

Coating grades

R = right hand version shown

L = left hand version

▲ In stock

Δ 2 weeks

Part number	s	f	a	r	t _{max a}	D _{a, min}	HIS	EG55
R114.4545.14	9	9	13.5	0.1	3	14	114090R	▲
L114.4545.14	9	9	13.5	0.1	3	14	114090L	▲

R = rotation clockwise. When using this face grooving insert in a B114 holder, the l1 and l2 will be enlarged by 3.0, 5.5, or 6.5 mm.

Machining in-front of center line

Dimensions in mm

P	●
M	●
K	●
N	-
S	-
H	-

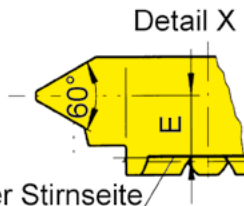
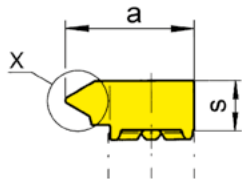
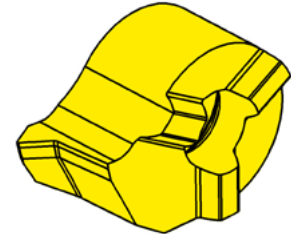
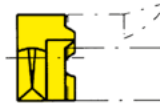
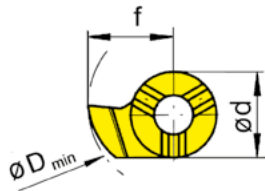
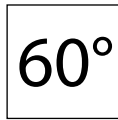
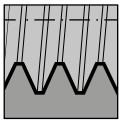

Klemhalter Stirnseite
Toolholder face

Coating grades

R = right hand version shown

L = left hand version

▲ In stock

Δ 2 weeks

Part number	P	TPI	TPI _{max}	E	f	a	d	s	D _{min}	HIS	Coating grades			
											EG55	IG35	TH35	TN35
R114.0205.01	0.5	28	64	4.8	9	13.5	9	5.5	14	114090R	▲		▲	▲
R114.0510.01	1	18	32	4.7	9	13.5	9	5.5	14	114090R	▲		▲	▲
R114.0815.01	1.5	12	20	4.5	9	13.5	9	5.5	14	114090R	▲	▲	▲	▲
R114.1020.01	2	11	16	4.2	9	13.5	9	5.5	14	114090R	▲	▲	▲	▲
R114.1325.01	2.5	9	12	4.2	9	13.5	9	5.5	14	114090R	▲	▲	▲	▲
L114.0205.01	0.5	28	64	4.8	9	13.5	9	5.5	14	114090L	Δ		▲	Δ
L114.0510.01	1	18	32	4.7	9	13.5	9	5.5	14	114090L	Δ		▲	▲
L114.0815.01	1.5	12	20	4.5	9	13.5	9	5.5	14	114090L	▲		▲	▲
L114.1020.01	2	11	16	4.2	9	13.5	9	5.5	14	114090L	Δ		▲	▲
L114.1325.01	2.5	9	12	4.2	9	13.5	9	5.5	14	114090L	Δ		▲	▲

Dimensions in mm

	P	M	K	N	S	H
EG55	●	●	●	●	●	●
IG35	●	●	●	-	-	-
TH35	●	●	●	●	●	●
TN35	●	●	●	●	●	●



Insert

S114

$\varnothing \geq 14 \text{ mm}$

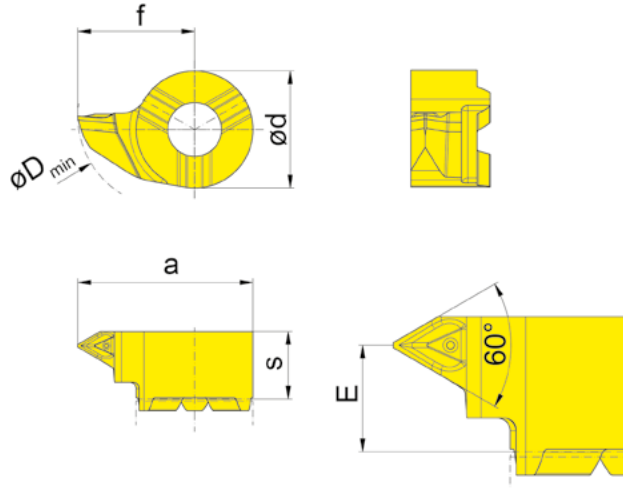

Coating grades

R = right hand version shown

L = left hand version

▲ In stock

Δ 2 weeks

Part number	P	TPI	TPI _{max}	E	f	a	d	s	D _{min}	HIS	EG55
RS114.0205.GM1	0.5	28	64	4.1	9	13.5	9	5.2	14	114090R	▲
RS114.0510.GM1	1	18	32	4.1	9	13.5	9	5.2	14	114090R	▲
RS114.0815.GM1	1.5	12	20	4.1	9	13.5	9	5.2	14	114090R	▲
RS114.1020.GM1	2	11	16	4.1	9	13.5	9	5.2	14	114090R	▲
RS114.1325.GM1	2.5	9	12	4.1	9	13.5	9	5.2	14	114090R	▲
LS114.0205.GM1	0.5	28	64	4.1	9	13.5	9	5.2	14	114090L	▲
LS114.0510.GM1	1	18	32	4.1	9	13.5	9	5.2	14	114090L	▲
LS114.0815.GM1	1.5	12	20	4.1	9	13.5	9	5.2	14	114090L	▲
LS114.1020.GM1	2	11	16	4.1	9	13.5	9	5.2	14	114090L	▲
LS114.1325.GM1	2.5	9	12	4.1	9	13.5	9	5.2	14	114090L	▲

Dimensions in mm

P	●
M	●
K	●
N	-
S	-
H	-

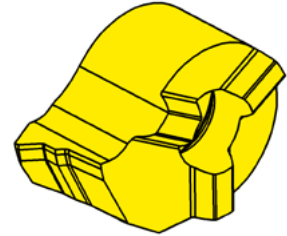
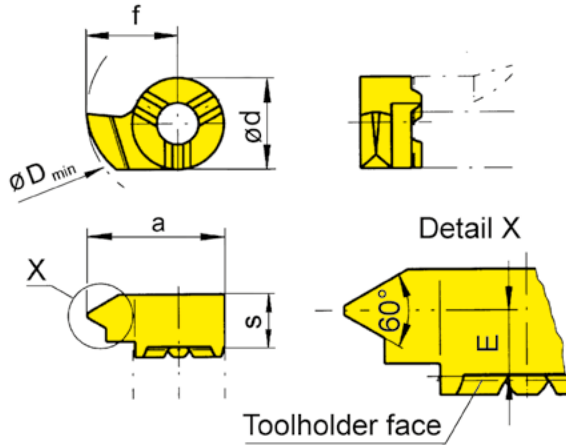

Coating grades

R = right hand version shown

L = left hand version

▲ In stock

△ 2 weeks

Part number	P	E	f	a	d	s	D _{min}	HIS	EG55	TN35
R114.0510.02	1	4.7	9	13.5	9	5.5	14	114090R	▲	▲
R114.0815.02	1.5	4.5	9	13.5	9	5.5	14	114090R	▲	▲
R114.1020.02	2	4.2	9	13.5	9	5.5	14	114090R	▲	▲
R114.1325.02	2.5	4.2	9	13.5	9	5.5	14	114090R	▲	▲
L114.0510.02	1	4.7	9	13.5	9	5.5	14	114090L	△	▲
L114.0815.02	1.5	4.5	9	13.5	9	5.5	14	114090L	△	▲
L114.1020.02	2	4.2	9	13.5	9	5.5	14	114090L	△	▲
L114.1325.02	2.5	4.2	9	13.5	9	5.5	14	114090L	△	▲

Dimensions in mm

P	●	●
M	●	-
K	●	●
N	-	o
S	-	-
H	-	-



Insert

S114 $\varnothing \geq 14$ mm

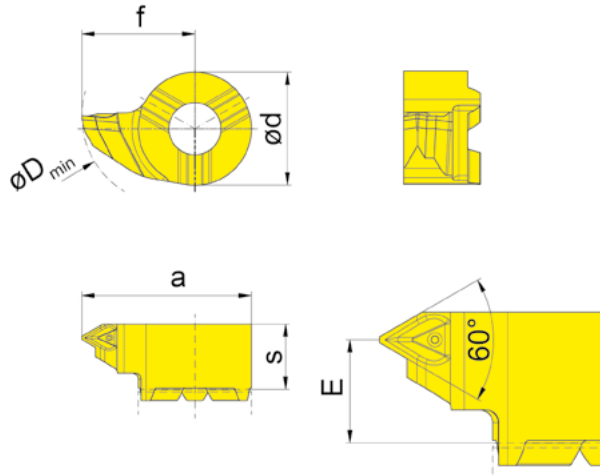

Coating grades

R = right hand version shown

L = left hand version

▲ In stock

Δ 2 weeks

Part number	P	E	f	a	d	s	D _{min}	HIS	EG55
RS114.0510.GM2	1	4.1	9	13.5	9	5.2	14	114090R	▲
RS114.0815.GM2	1.5	4.1	9	13.5	9	5.2	14	114090R	▲
RS114.1020.GM2	2	4.1	9	13.5	9	5.2	14	114090R	▲
RS114.1325.GM2	2.5	4.1	9	13.5	9	5.2	14	114090R	▲
LS114.0510.GM2	1	4.1	9	13.5	9	5.2	14	114090L	▲
LS114.0815.GM2	1.5	4.1	9	13.5	9	5.2	14	114090L	▲
LS114.1020.GM2	2	4.1	9	13.5	9	5.2	14	114090L	▲
LS114.1325.GM2	2.5	4.1	9	13.5	9	5.2	14	114090L	▲

Dimensions in mm

P	●
M	●
K	●
N	-
S	-
H	-

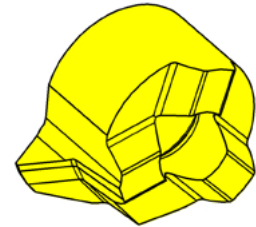
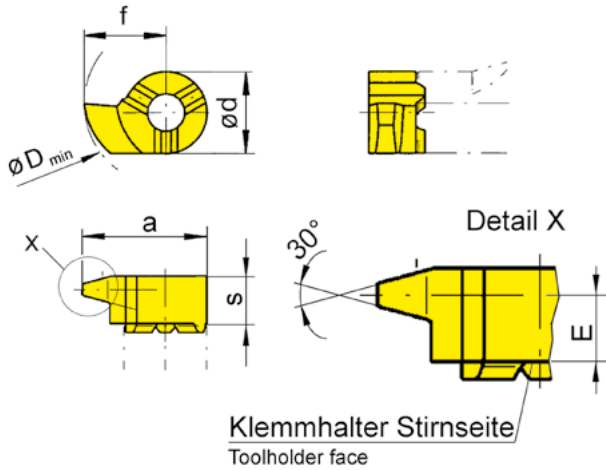

Coating grades

R = right hand version shown

L = left hand version

▲ In stock

Δ 2 weeks

Part number	P	E	f	a	d	s	D _{min}	HIS	EG55	TN35
R114.1730.01	3	4.3	9	13.5	9	5.5	14	114090R		Δ
R114.2240.01	4	4	9	13.5	9	5.5	14	114090R	▲	▲
R114.2750.01	5	3.55	9	13.5	9	5.5	14	114090R	▲	▲
L114.2240.01	4	4	9	13.5	9	5.5	14	114090L	▲	▲
L114.2750.01	5	3.55	9	13.5	9	5.5	14	114090L	Δ	▲

These inserts produces a trapezoidal thread profile

Dimensions in mm

P	●	●
M	●	-
K	●	●
N	-	○
S	-	-
H	-	-



 YouTube
@HornUSAinc



Scan or click

**VISIT THE HORN USA YOUTUBE CHANNEL
FOR VIDEOS ON:**

Precision Tooling Education
High-Performance Application Demos
Tips and Tricks
In-depth Technical Discussions



K

MINI 116

Bore Ø		Tool System											
mm	in	105	109	110	106	107	108	10P	111	11P	114	116	18P
≥ 0.2	≥ .0079	•											
≥ 0.5	≥ .0197	•											
≥ 0.7	≥ .0276	•											
≥ 1.0	≥ .0394	•											
≥ 1.5	≥ .0591	•											
≥ 2.0	≥ .0787	•											
≥ 3.0	≥ .1181	•											
≥ 4.0	≥ .1575	•											
≥ 5.0	≥ .1969	•											
≥ 6.0	≥ .2362	•	•	•	•								
≥ 6.8	≥ .2677		•	•	•								
≥ 7.0	≥ .2756		•			•							
≥ 7.8	≥ .3071			•		•	•						
≥ 8.0	≥ .3150			•		•	•						
≥ 9.0	≥ .3543			•		•	•	•					
≥ 10.0	≥ .3937			•				•	•	•			
≥ 10.5	≥ .4134									•			
≥ 11.0	≥ .4331								•	•			
≥ 11.5	≥ .4528									•			
≥ 13.8	≥ .5433										•		
≥ 14.0	≥ .5512										•	•	
≥ 16.0	≥ .6299									•		•	
≥ 16.5	≥ .6496										[•]		
≥ 18.0	≥ .7087												•
Depth of groove		2.5	2.5	4.0	0.8	2.0	1.0	3.0	2.3	3.5	4.0, [6.5]	4.3	8.0
		.0984	.0984	.1575	.0315	.0787	.0394	.1181	.0906	.1378	.1575, [.2559]	.1693	.3150
Width of groove		0.5-2.0	1.0-2.0	1.0-3.0	0.7-1.5	1.0-2.0	0.7-2.0	1.0-3.0	0.7-3.0	1.0-3.0	0.7-3.0	0.7-4.0	2.0-3.0
		.0197-.0787	.0394-.0787	.0394-.1181	.0276-.0591	.0394-.0787	.0276-.0787	.0394-.1181	.0276-.1181	.0394-.1181	.0276-.1181	.0276-.1575	.0787-.1181
Operations													
Grooving		•	•	•	•	•	•	•	•	•	•	•	•
Boring		•	•	•	•	•	•		•		•	•	
Threading		•	•			•	•		•		•	•	
Chamfering		•	•			•	•		•		•	•	
Face Grooving		•	•	•							•		
Boring and Profiling		•					•	•	•	•	•	•	

K

HOLDERS

Round Shank

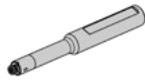

Page 399
Holder BU116
Inch Shank

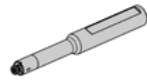

Page 400-401
Holder B116

INSERTS

Boring

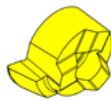

Page 402
Bore Contouring

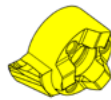

Page 403
Bore Contouring
.R Chipbreaker

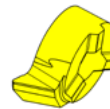

Page 404-405
Bore Contouring
and Profiling

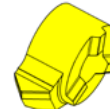

Page 406
Chamfering, Profi-
ling, Back Boring

Grooving



Page 407-408
Grooving
Inch



Page 409-411
Grooving

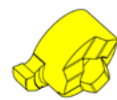

Page 412
Grooving
.D Chipbreaker



Page 413
Grooving
Full Radius, Inch



Page 414
Grooving
Full Radius



Page 415
Pre-Part Off



Page 416-417
Fine Finishing

Threading



Page 418
Threading, 60°
Partial Profile

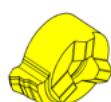

Page 419
Threading, 60°
.GM Chipbreaker, Partial



Page 420
Threading, 60°
Full Profile

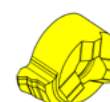

Page 421
Threading, 60°
.GM Chipbreaker, Full



Page 422
Threading
ACME

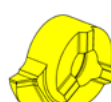

Page 423
Threading
Trapezoidal

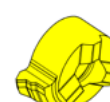

Page 424
Threading
BSW-BSF

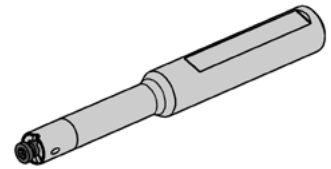
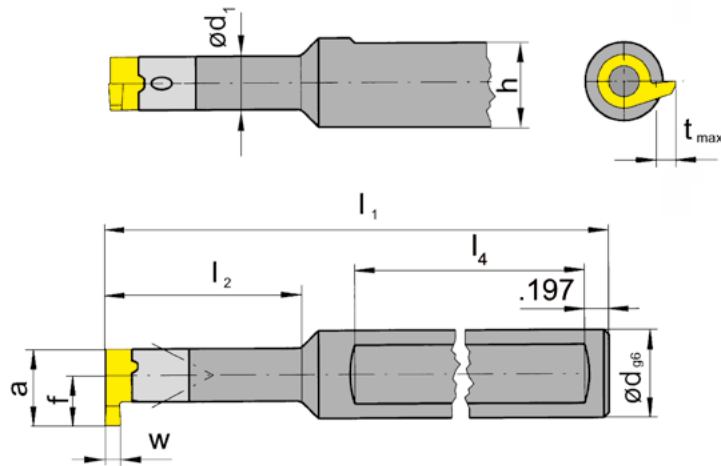
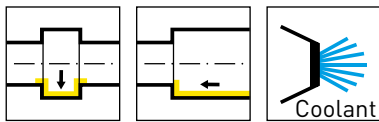

Picture = right hand insert shown

Part number	d	l_1	l_2	h	l_4	d_1	HWS
BU116.0500.01	.500	5.118	1.575	.461	1.969	.433	116110R • 116110L
BU116.0500.02	.500	5.118	2.205	.461	1.969	.433	116110R • 116110L
BU116.0500.03	.500	5.906	3.150	.461	1.969	.433	116110R • 116110L
BU116.0625.01	.625	5.118	1.575	.586	1.969	.433	116110R • 116110L
BU116.0625.02	.625	5.118	2.205	.586	1.969	.433	116110R • 116110L
BU116.0625.03	.625	5.906	3.150	.586	1.969	.433	116110R • 116110L
BU116.ST05.00	.500	3.150	.787	.460	1.772	.433	116110R • 116110L
BU116.ST06.00	.625	3.150	.787	.585	1.772	.433	116110R • 116110L

Holders with ".ST" are steel shanks

For w, a, tmax and f dimensions, see insert pages

Dimensions in inch



K

Spare Parts

Toolholder	Clamping Screw	TORX PLUS® Wrench	Torque Value
BU116...	5.13T20EP	T20PQ	6.5 Nm

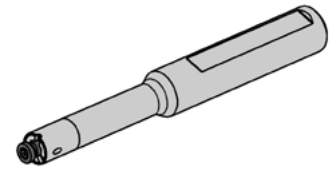
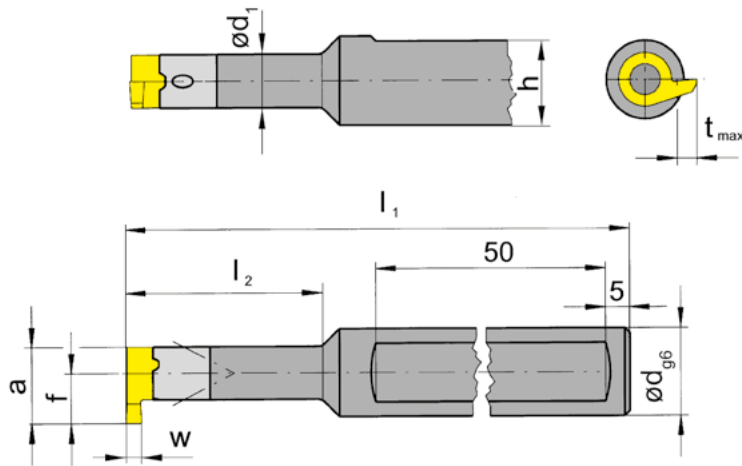
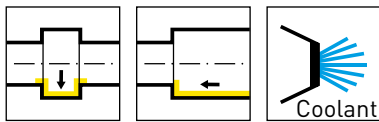

Picture = right hand insert shown

Part number	d	l_1	l_2	h	d_1	HWS
B116.0012.01	12	130	40	11	11	116110R • 116110L
B116.0012.02	12	130	56	11	11	116110R • 116110L
B116.0012.03	12	150	80	11	11	116110R • 116110L
B116.0016.01	16	130	40	15	11	116110R • 116110L
B116.0016.02	16	130	56	15	11	116110R • 116110L
B116.0016.03	16	150	80	15	11	116110R • 116110L

For w, a, t_{max} and f dimensions, see insert pages

1 clamping flat

Dimensions in mm

Spare Parts

Toolholder	Clamping Screw	TORX PLUS® Wrench	Torque Value
B116...	5.13T20EP	T20PQ	6.5 Nm

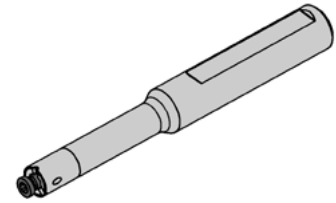
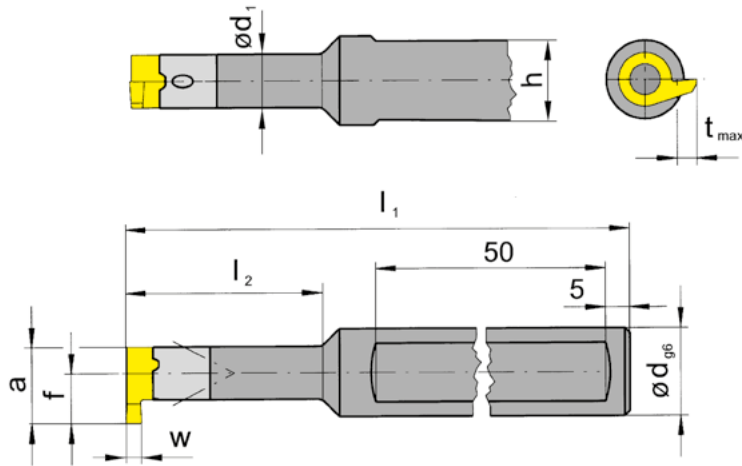
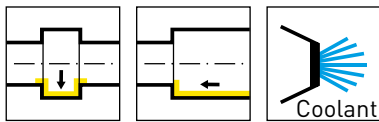

Picture = right hand insert shown

Part number	d	l_1	l_2	h	d_1	HWS
B116.0012.2.01	12	130	40	11	11	116110R • 116110L
B116.0012.2.02	12	130	56	11	11	116110R • 116110L
B116.0012.2.03	12	150	80	11	11	116110R • 116110L
B116.0016.2.01	16	130	40	14	11	116110R • 116110L
B116.0016.2.02	16	130	56	14	11	116110R • 116110L
B116.0016.2.03	16	150	80	14	11	116110R • 116110L

For w, a, tmax and f dimensions, see insert pages

2 clamping flats

Dimensions in mm

Spare Parts

Toolholder	Clamping Screw	TORX PLUS® Wrench	Torque Value
B116...	5.13T20EP	T20PQ	6.5 Nm

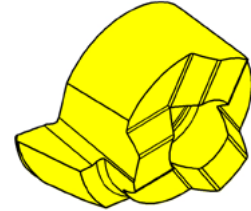
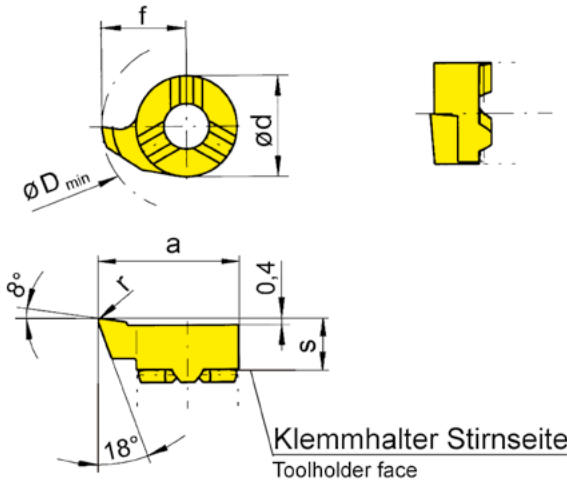
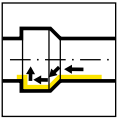

Coating grades

R = right hand version shown

L = left hand version

▲ In stock

Δ 2 weeks

Part number	s	f	a	r	d	D _{min}	HIS	EG55	IG35	TH35	TN35
R116.1897.02	5.3	9.7	15.2	0.2	11	15.5	116110R	▲	▲	▲	▲
L116.1897.02	5.3	9.7	15.2	0.2	11	15.5	116110L	▲	▲	▲	▲

Dimensions in mm

P	●	●	●	●
M	●	●	●	-
K	●	●	●	●
N	-	○	-	○
S	-	○	-	-
H	-	-	-	-

K

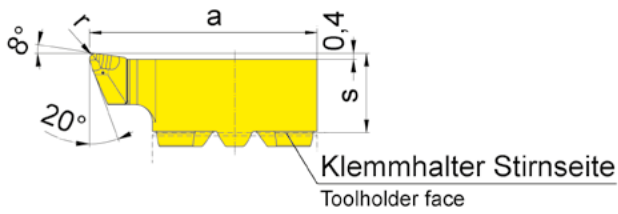
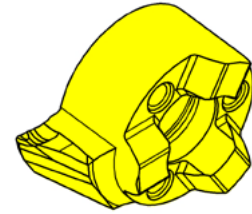
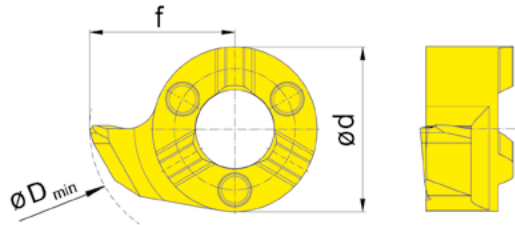
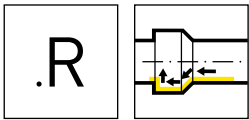

R = right hand version shown

L = left hand version

Coating grades
 ▲ In stock Δ 2 weeks

Part number	s	f	a	r	d	D _{min}	HIS	EG55	TH35
RS116.1897.R2	5.3	9.7	15.2	0.2	11	15.5	116110R	▲	▲
RS116.1897.R4	5.3	9.7	15.2	0.4	11	15.5	116110R	▲	▲
LS116.1897.R2	5.3	9.7	15.2	0.2	11	15.5	116110L	▲	▲
LS116.1897.R4	5.3	9.7	15.2	0.4	11	15.5	116110L	▲	▲

Dimensions in mm

P	●	●
M	●	●
K	●	●
N	-	-
S	-	-
H	-	-

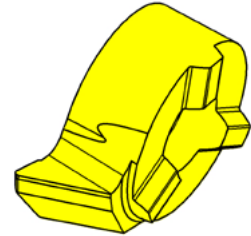
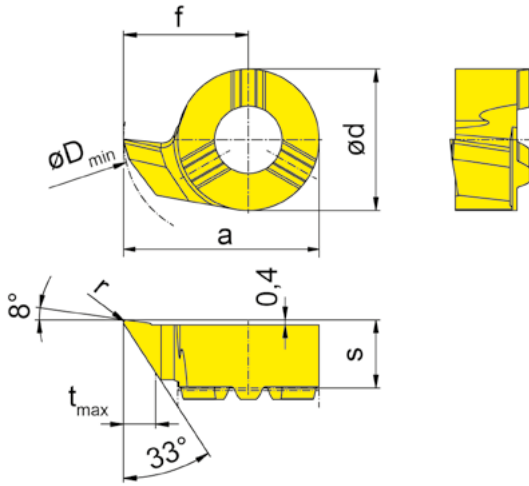
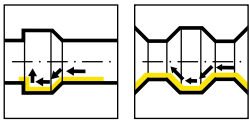

Coating grades

R = right hand version shown

L = left hand version

▲ In stock

△ 2 weeks

Part number	s	f	a	r	d	t _{max}	D _{min}	HIS	EG55
R116.3302.02	5.3	9.7	15.2	0.2	11	2.5	15.5	116110R	▲
R116.3302.04	5.3	9.7	15.2	0.4	11	2.5	15.5	116110R	▲
L116.3302.02	5.3	9.7	15.2	0.2	11	2.5	15.5	116110L	△
L116.3302.04	5.3	9.7	15.2	0.4	11	2.5	15.5	116110L	△

Dimensions in mm

P	●
M	●
K	●
N	-
S	-
H	-

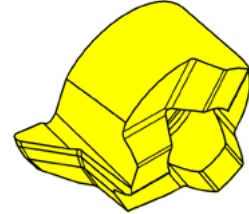
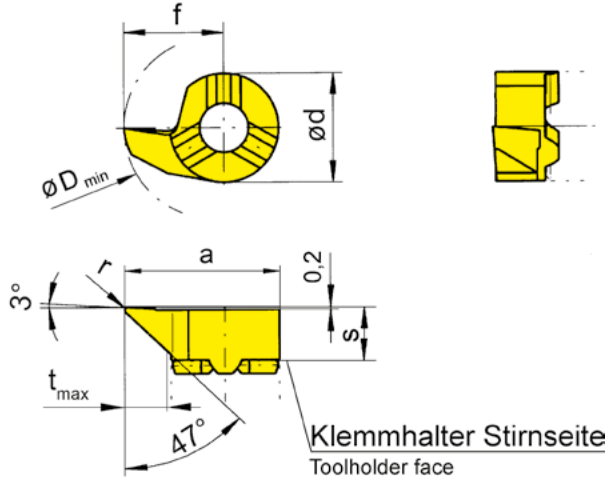
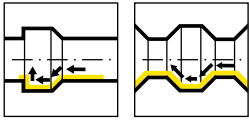

Coating grades

R = right hand version shown

L = left hand version

▲ In stock

Δ 2 weeks

Part number	s	f	a	r	d	t _{max}	D _{min}	HIS	Coating grades					
									EG55	IG35	TH35	TN35		
R116.4702.02	5.3	10.2	15.7	0.2	11	4.3	16	116110R	▲	▲	▲	▲		
R116.4702.04	5.3	10.2	15.7	0.4	11	4.3	16	116110R	▲	▲	▲	▲		
L116.4702.02	5.3	10.2	15.7	0.2	11	4.3	16	116110L	▲	▲	▲	▲		
L116.4702.04	5.3	10.2	15.7	0.4	11	4.3	16	116110L	▲	▲	▲	▲		
Dimensions in mm										P	●	●	●	●
										M	●	●	●	-
										K	●	●	●	●
										N	-	○	-	○
										S	-	○	-	-
										H	-	-	-	-

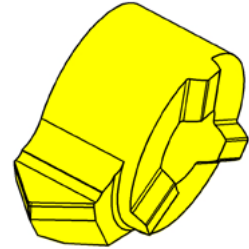
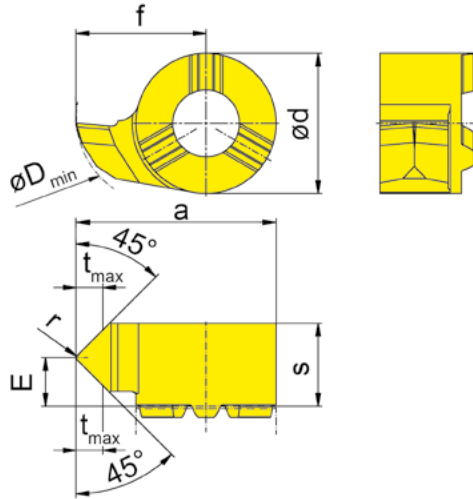
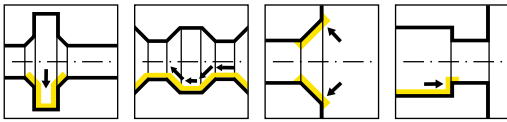

Coating grades

R = right hand version shown

L = left hand version

▲ In stock

Δ 2 weeks

Part number	E	s	f	a	r	d	t _{max}	D _{min}	HIS	EG55
R116.4545.02	3.8	6.5	10.2	15.7	0.2	11	2.1	16	116110R	▲
L116.4545.02	3.8	6.5	10.2	15.7	0.2	11	2.1	16	116110L	Δ

Dimensions in mm

P	●
M	●
K	●
N	-
S	-
H	-

K

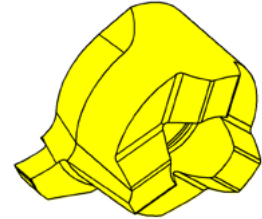
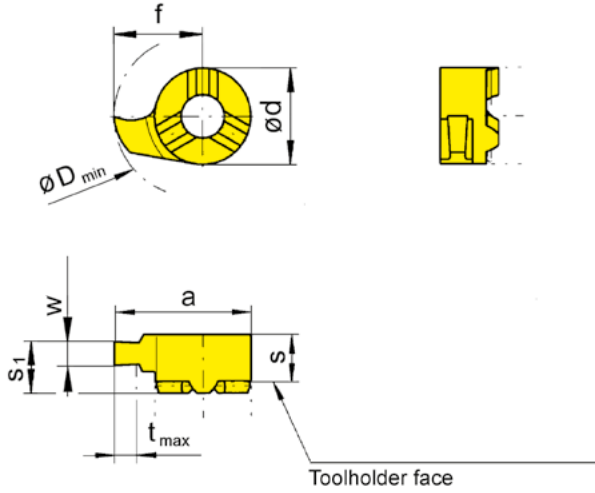
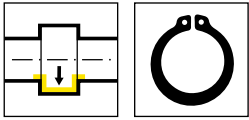

R = right hand version shown

L = left hand version

▲ In stock

Δ 2 weeks

Coating grades

Part number	w	s	f	a	d	t _{max}	D _{min}	HIS	Coating grades			
									IG35	TH35	TN35	
RU116.0031.00	.031	.217	.402	.618	.433	.059	.630	116110R	▲	▲	▲	
RU116.0039.00	.039	.217	.402	.618	.433	.059	.630	116110R	▲	▲	▲	
LU116.0031.00	.031	.217	.402	.618	.433	.059	.630	116110L	▲	▲	▲	
.031 and .039 widths are not face cutting and have limited depths of cut									P	●	●	●
Dimensions in inch									M	●	●	-
									K	●	●	●
									N	o	-	o
									S	o	-	-
									H	-	-	-

K

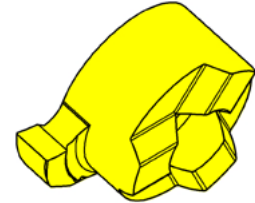
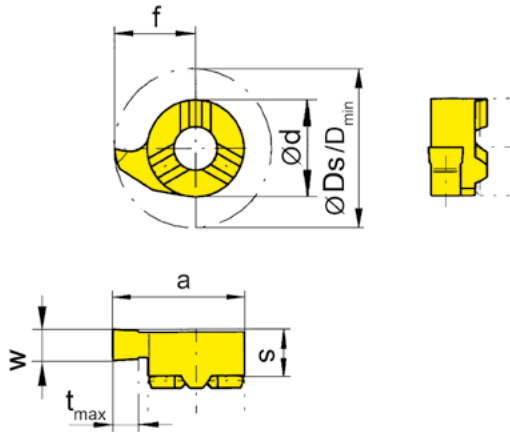
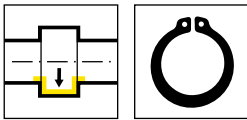

Coating grades

R = right hand version shown

L = left hand version

▲ In stock

Δ 2 weeks

Part number	w	s	f	Ds	a	d	t _{max}	D _{min}	HIS	MG12	IG35	TF45	TH35	TN35
RU116.0046.00	.046	.217	.402	.803	.618	.433	.169	.630	116110R		▲		▲	▲
RU116.0062.00	.062	.209	.402	.803	.618	.433	.169	.630	116110R	▲	▲	Δ	▲	▲
RU116.0078.00	.078	.209	.402	.803	.618	.433	.169	.630	116110R		▲		▲	▲
RU116.0094.00	.094	.209	.402	.803	.618	.433	.169	.630	116110R	▲	▲	Δ	▲	▲
RU116.0125.00	.125	.209	.402	.803	.618	.433	.169	.630	116110R	▲	▲	▲	▲	▲
RU116.0056.00	.056	.209	.402	.803	.618	.433	.169	.630	116110R		▲		▲	▲
LU116.0046.00	.046	.217	.402	.803	.618	.433	.169	.630	116110L		▲		▲	▲
LU116.0062.00	.062	.209	.402	.803	.618	.433	.169	.630	116110L		▲		▲	▲
LU116.0078.00	.078	.209	.402	.803	.618	.433	.169	.630	116110L		▲		▲	▲
LU116.0094.00	.094	.209	.402	.803	.618	.433	.169	.630	116110L		▲		▲	▲
LU116.0125.00	.125	.209	.402	.803	.618	.433	.169	.630	116110L		▲		▲	▲

Dimensions in inch



P	-	●	-	●	●
M	-	●	-	●	-
K	-	●	-	●	●
N	●	○	-	-	○
S	-	○	-	-	-
H	-	-	-	-	-

K

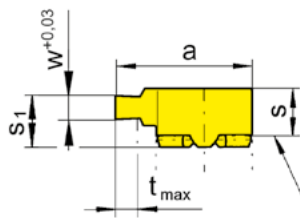
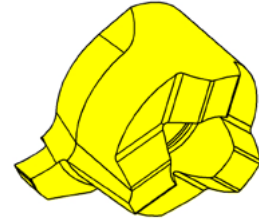
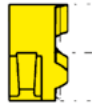
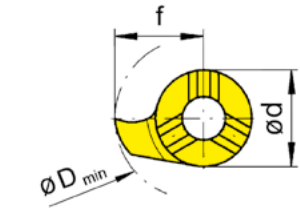
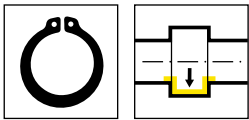

Klemmhalter Stirnseite
Toolholder face

Coating grades

R = right hand version shown

L = left hand version

▲ In stock

Δ 2 weeks

Part number	w	s	f	a	s ₁	d	t _{max}	D _{min}	HIS	EG55	TN35
R116.0070.00	0.74	5.5	10.2	15.7	5.3	11	1.2	16	116110R	▲	▲
R116.0080.00	0.84	5.5	10.2	15.7	5.3	11	1.3	16	116110R	▲	▲
R116.0090.00	0.94	5.5	10.2	15.7	5.3	11	1.5	16	116110R	▲	▲
L116.0070.00	0.74	5.5	10.2	15.7	5.3	11	1.2	16	116110L	Δ	▲
L116.0080.00	0.84	5.5	10.2	15.7	5.3	11	1.3	16	116110L	Δ	Δ
L116.0090.00	0.94	5.5	10.2	15.7	5.3	11	1.5	16	116110L	Δ	▲

Not face cutting, limited depth of cut

Dimensions in mm

P	●	●
M	●	-
K	●	●
N	-	o
S	-	-
H	-	-

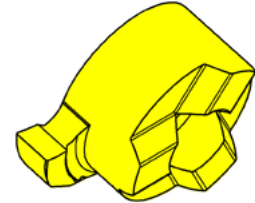
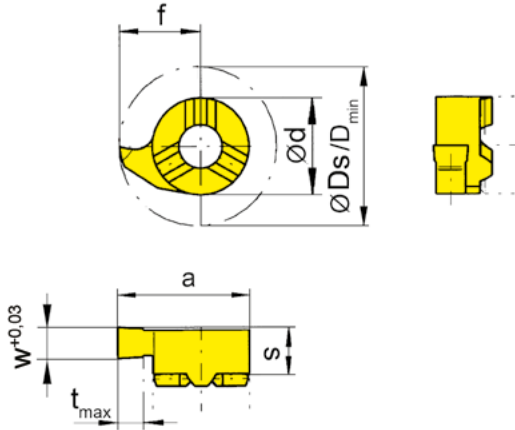
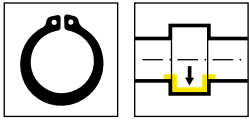

Coating grades

R = right hand version shown

L = left hand version

▲ In stock

Δ 2 weeks

Part number	w	s	f	Ds	a	d	t _{max}	D _{min}	HIS	EG55	IG35	TH35	TN35
R116.0110.00	1.19	5.3	10.2	20.4	15.7	11	4.3	16	116110R	▲		▲	▲
R116.0130.00	1.39	5.3	10.2	20.4	15.7	11	4.3	16	116110R	▲		▲	▲
R116.0160.00	1.69	5.3	10.2	20.4	15.7	11	4.3	16	116110R	▲	▲	▲	▲
L116.0110.00	1.19	5.3	10.2	20.4	15.7	11	4.3	16	116110L			▲	▲
L116.0130.00	1.39	5.3	10.2	20.4	15.7	11	4.3	16	116110L			▲	▲
L116.0160.00	1.69	5.3	10.2	20.4	15.7	11	4.3	16	116110L			▲	▲

Dimensions in mm

P	●	●	●	●
M	●	●	●	-
K	●	●	●	●
N	-	○	-	○
S	-	○	-	-
H	-	-	-	-

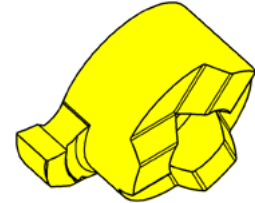
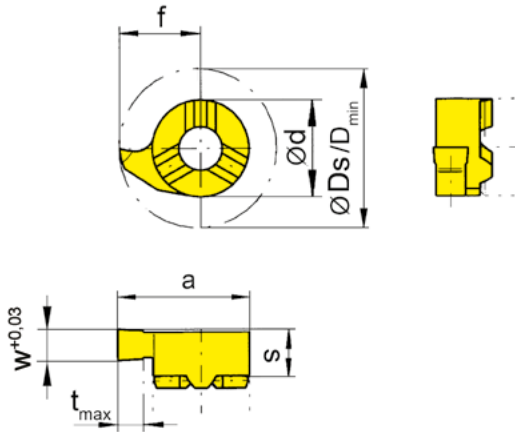
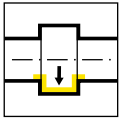

Coating grades

R = right hand version shown

L = left hand version

▲ In stock

Δ 2 weeks

Part number	w	s	f	Ds	a	d	t _{max}	D _{min}	Z	HIS	EG55	IG35	TH35	TN35
R116.0200.00	2	5.3	10.2	20.4	15.7	11	4.3	16	1	116110R	▲		▲	▲
R116.0250.00	2.5	5.3	10.2	20.4	15.7	11	4.3	16	1	116110R	▲	▲	▲	▲
R116.0300.00	3	5.3	10.2	20.4	15.7	11	4.3	16	1	116110R	▲	▲	▲	▲
R116.0350.00	3.5	5.3	10.2	20.4	15.7	11	4.3	16	1	116110R	▲	▲	▲	▲
R116.0400.00	4	5.3	10.2	20.4	15.7	11	4.3	16	1	116110R	▲	▲	▲	▲
L116.0200.00	2	5.3	10.2	20.4	15.7	11	4.3	16	1	116110L	▲		▲	▲
L116.0250.00	2.5	5.3	10.2	20.4	15.7	11	4.3	16	1	116110L			▲	▲
L116.0300.00	3	5.3	10.2	20.4	15.7	11	4.3	16	1	116110L	▲		▲	▲
L116.0350.00	3.5	5.3	10.2	20.4	15.7	11	4.3	16	1	116110L			▲	▲
L116.0400.00	4	5.3	10.2	20.4	15.7	11	4.3	16	1	116110L			▲	▲

Dimensions in mm

P	●	●	●	●
M	●	●	●	-
K	●	●	●	●
N	-	○	-	○
S	-	○	-	-
H	-	-	-	-

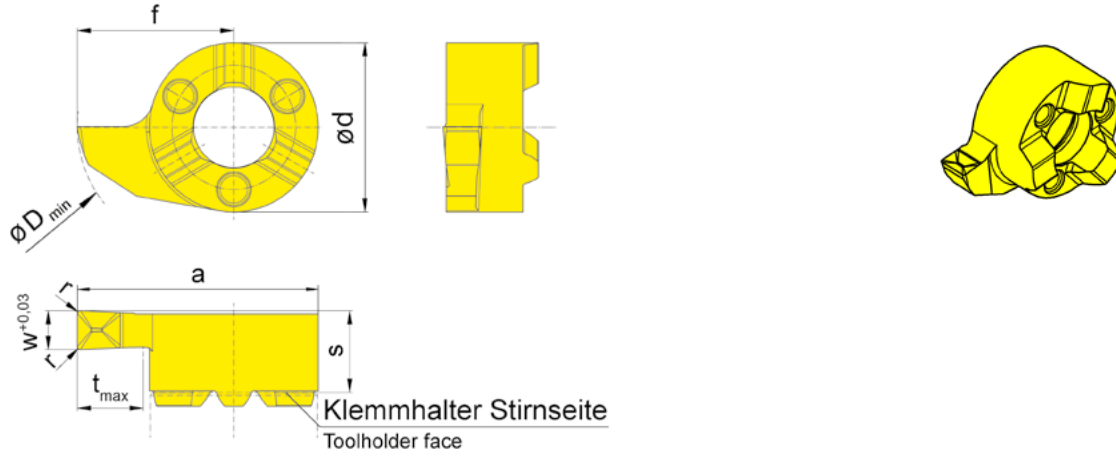
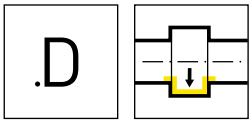

Coating grades

R = right hand version shown

L = left hand version

▲ In stock

Δ 2 weeks

Part number	w	s	f	a	r	d	t _{max}	D _{min}	HIS	EG55	TH35
RS116.0200.D2	2	5.3	10.2	15.7	0.2	11	4.3	16	116110R	▲	▲
RS116.0250.D2	2.5	5.3	10.2	15.7	0.2	11	4.3	16	116110R	▲	▲
RS116.0300.D2	3	5.3	10.2	15.7	0.2	11	4.3	16	116110R	▲	▲
LS116.0200.D2	2	5.3	10.2	15.7	0.2	11	4.3	16	116110L		▲
LS116.0250.D2	2.5	5.3	10.2	15.7	0.2	11	4.3	16	116110L		▲
LS116.0300.D2	3	5.3	10.2	15.7	0.2	11	4.3	16	116110L	Δ	▲

Dimensions in mm

P	●	●
M	●	●
K	●	●
N	-	-
S	-	-
H	-	-

K

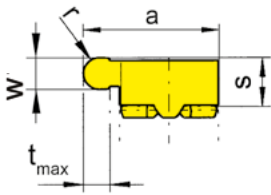
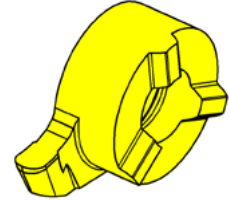
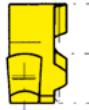
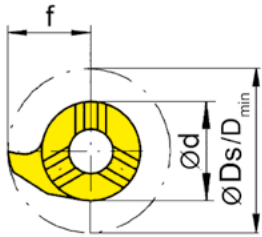
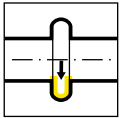

Coating grades

R = right hand version shown

L = left hand version

▲ In stock

Δ 2 weeks

Part number	w	f	Ds	r	d	D _{min}	Z	HIS	Coating grades			
									IG35	TH35	TN35	
RU116.0031.62	.062	.402	.803	.032	.433	.630	1.000	116110R	▲	▲	▲	
RU116.0039.78	.078	.402	.803	.039	.433	.630	1.000	116110R	▲	▲	▲	
RU116.0047.94	.094	.402	.803	.047	.433	.630	1.000	116110R	▲	▲	▲	
RU116.0062.12	.125	.402	.803	.063	.433	.630	1.000	116110R	▲	▲	▲	
LU116.0031.62	.062	.402	.803	.032	.433	.630	1.000	116110L	▲		▲	
LU116.0039.78	.078	.402	.803	.039	.433	.630	1.000	116110L	▲		▲	
LU116.0047.94	.094	.402	.803	.047	.433	.630	1.000	116110L	▲		▲	
LU116.0062.12	.125	.402	.803	.063	.433	.630	1.000	116110L	▲		▲	
									P	●	●	●
									M	●	●	-
									K	●	●	●
									N	○	-	○
									S	○	-	-
									H	-	-	-

Dimensions in inch



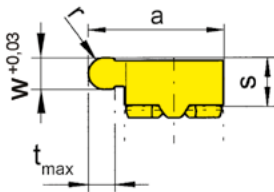
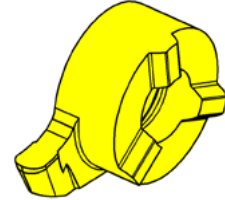
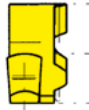
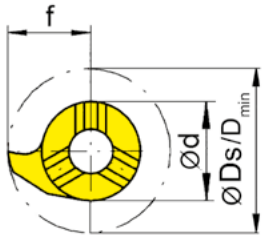
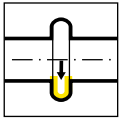

Coating grades

R = right hand version shown

L = left hand version

▲ In stock

Δ 2 weeks

Part number	w	s	f	Ds	a	r	d	t _{max}	D _{min}	Z	HIS	Coating grades				
												EG55	IG35	TH35	TN35	
R116.0009.18	1.8	5.3	10.2	20.4	15.7	0.9	11	4.3	16	1	116110R	▲		▲	▲	
R116.0011.22	2.2	5.3	10.2	20.4	15.7	1.1	11	4.3	16	1	116110R	▲	▲	▲	▲	
R116.0015.30	3	5.3	10.2	20.4	15.7	1.5	11	4.3	16	1	116110R	▲		▲	▲	
R116.0020.40	4	5.3	10.2	20.4	15.7	2	11	4.3	16	1	116110R	▲		▲	▲	
L116.0009.18	1.8	5.3	10.2	20.4	15.7	0.9	11	4.3	16	1	116110L	▲		▲	▲	
L116.0011.22	2.2	5.3	10.2	20.4	15.7	1.1	11	4.3	16	1	116110L	▲		▲	▲	
L116.0015.30	3	5.3	10.2	20.4	15.7	1.5	11	4.3	16	1	116110L	▲	▲	▲	▲	
L116.0020.40	4	5.3	10.2	20.4	15.7	2	11	4.3	16	1	116110L	▲		▲	▲	
Dimensions in mm												P	●	●	●	●
												M	●	●	●	-
												K	●	●	●	●
												N	-	○	-	○
												S	-	○	-	-
												H	-	-	-	-

K

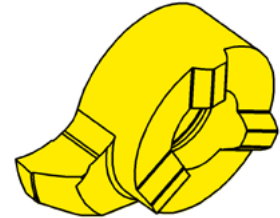
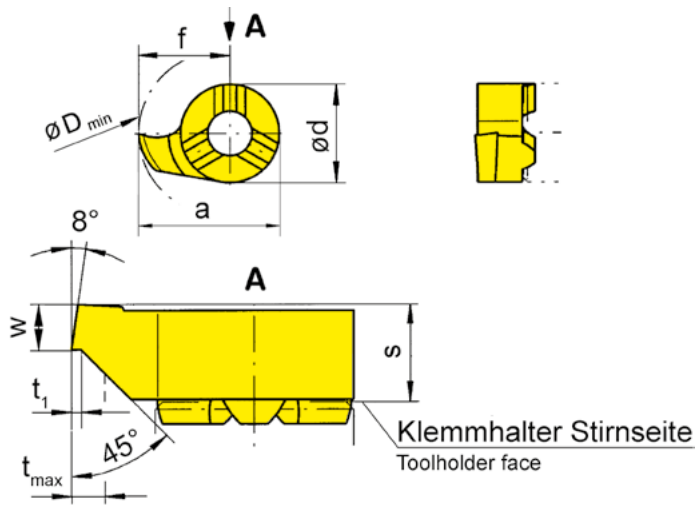
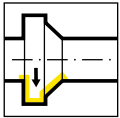

Coating grades

R = right hand version shown

L = left hand version

▲ In stock

Δ 2 weeks

Part number	w	s	f	a	d	t _{max}	t ₁	D _{min}	HIS	EG55	IG35	TI25
R116.0815.45	1.5	5.3	10.2	15.7	11	1.5	0.2	16	116110R	▲	▲	▲
L116.0815.45	1.5	5.3	10.2	15.7	11	1.5	0.2	16	116110L	▲	▲	▲

Dimensions in mm

P	●	●	●
M	●	●	●
K	●	●	-
N	-	○	●
S	-	○	-
H	-	-	-

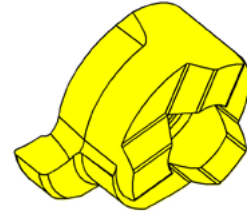
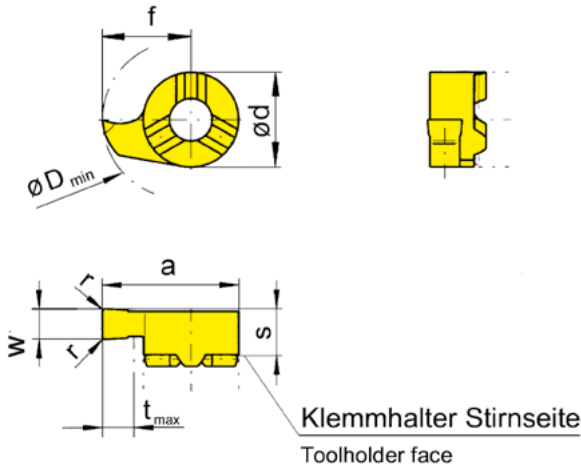
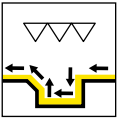

Coating grades

R = right hand version shown

L = left hand version

▲ In stock

△ 2 weeks

Part number	w	s	f	a	r	d	t _{max}	D _{min}	HIS	MG12	IG35	TF45	TH35	TI25	TN35
RU116.0062.08	.062	.209	.402	.618	.008	.433	.169	.630	116110R		▲	▲	▲	△	▲
RU116.0094.08	.094	.209	.402	.618	.008	.433	.169	.630	116110R		▲	▲	▲		▲
RU116.0046.08	.046	.209	.402	.618	.008	.433	.169	.630	116110R		▲		▲		▲
RU116.0078.08	.078	.209	.402	.618	.008	.433	.169	.630	116110R	△	▲		▲		▲
RU116.0046.16	.046	.209	.402	.618	.016	.433	.169	.630	116110R	△	▲		▲		▲
RU116.0094.16	.094	.209	.402	.618	.016	.433	.169	.630	116110R		▲		▲		▲
RU116.0125.08	.125	.209	.402	.618	.008	.433	.169	.630	116110R	▲	▲		▲		▲
RU116.0125.16	.125	.209	.402	.618	.016	.433	.169	.630	116110R		▲		▲		▲
RU116.0031.08	.031	.209	.402	.618	.008	.433	.169	.630	116110R	▲	▲		▲		▲
RU116.0062.16	.062	.209	.402	.618	.016	.433	.169	.630	116110R		▲		▲		▲
RU116.0078.16	.078	.209	.402	.618	.016	.433	.169	.630	116110R		▲		▲		▲
LU116.0062.08	.062	.209	.402	.618	.008	.433	.169	.630	116110L		▲				▲
LU116.0094.08	.094	.209	.402	.618	.008	.433	.169	.630	116110L		▲				▲
LU116.0046.08	.046	.209	.402	.618	.008	.433	.169	.630	116110L						△
LU116.0078.08	.078	.209	.402	.618	.008	.433	.169	.630	116110L		▲				▲
LU116.0046.16	.046	.209	.402	.618	.016	.433	.169	.630	116110L						△
LU116.0094.16	.094	.209	.402	.618	.016	.433	.169	.630	116110L						△
LU116.0125.08	.125	.209	.402	.618	.008	.433	.169	.630	116110L		▲				▲
LU116.0125.16	.125	.209	.402	.618	.016	.433	.169	.630	116110L		▲				▲
LU116.0031.08	.031	.209	.402	.618	.008	.433	.169	.630	116110L		▲				▲

These inserts are optimized for finishing passes

Dimensions in inch



P	-	●	-	●	●	●
M	-	●	-	●	●	-
K	-	●	-	●	-	●
N	●	○	-	-	●	○
S	-	○	-	-	-	-
H	-	-	-	-	-	-



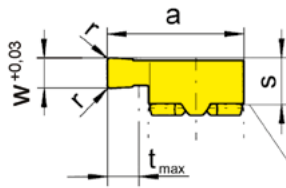
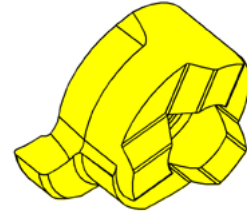
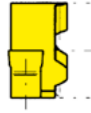
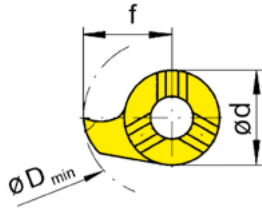
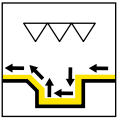

Klemmhalter Stirnseite
Toolholder face

Coating grades

R = right hand version shown

L = left hand version

▲ In stock

Δ 2 weeks

Part number	w	s	f	a	r	d	t _{max}	D _{min}	HIS	EG55	IG35	TH35	TN35
R116.0200.02	2	5.3	10.2	15.7	0.2	11	4.3	16	116110R	▲	▲	▲	▲
L116.0200.02	2	5.3	10.2	15.7	0.2	11	4.3	16	116110L	▲	▲	▲	▲

These inserts are optimized for finishing passes

Dimensions in mm

P	●	●	●	●
M	●	●	●	-
K	●	●	●	●
N	-	○	-	○
S	-	○	-	-
H	-	-	-	-

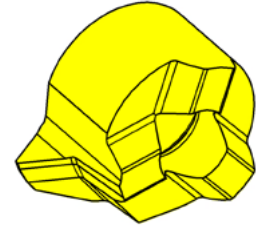
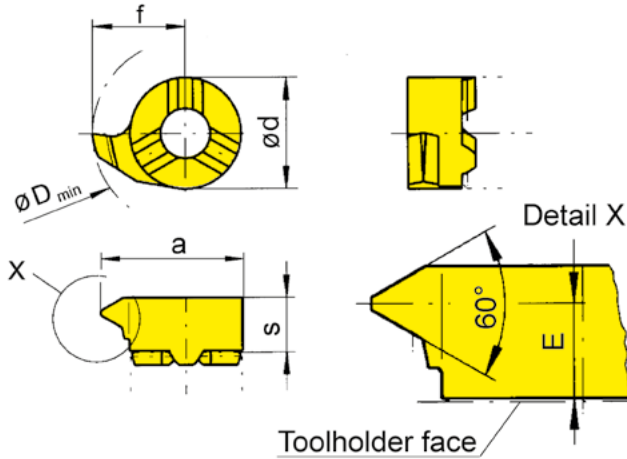

Coating grades

R = right hand version shown

L = left hand version

▲ In stock

Δ 2 weeks

Part number	P	TPI	TPI _{max}	E	f	a	d	s	D _{min}	HIS	Coating grades			
											EG55	IG35	TH35	TN35
R116.0510.01	1	18	32	4.7	10.2	15.7	11	5.5	16	116110R	▲		▲	▲
R116.0815.01	1.5	12	20	4.5	10.2	15.7	11	5.5	16	116110R	▲	▲	▲	▲
R116.1020.01	2	11	16	4.3	10.2	15.7	11	5.5	16	116110R	▲	▲	▲	▲
R116.1325.01	2.5	9	12	4.2	10.2	15.7	11	5.5	16	116110R	▲	▲	▲	▲
L116.0510.01	1	18	32	4.7	10.2	15.7	11	5.5	16	116110L	Δ	▲		Δ
L116.0815.01	1.5	12	20	4.5	10.2	15.7	11	5.5	16	116110L	Δ		▲	▲
L116.1020.01	2	11	16	4.3	10.2	15.7	11	5.5	16	116110L	Δ	▲	▲	▲
L116.1325.01	2.5	9	12	4.2	10.2	15.7	11	5.5	16	116110L	Δ		▲	▲

Dimensions in mm

	P	M	K	N	S	H
EG55	●	●	●	●	●	●
IG35	●	●	●	●	-	-
TH35	●	●	●	●	●	●
TN35	●	●	●	●	●	●
EG55	●	●	●	●	●	●
IG35	●	●	●	●	-	-
TH35	●	●	●	●	●	●
TN35	●	●	●	●	●	●

K

Insert

S116 $\varnothing \geq 16$ mm

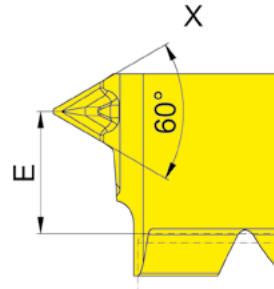
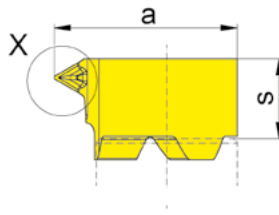
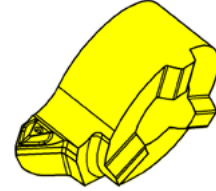
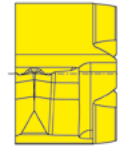
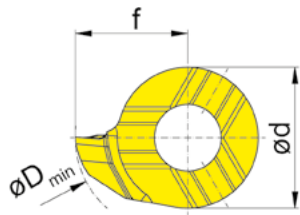

Coating grades

R = right hand version shown

L = left hand version

▲ In stock

Δ 2 weeks

Part number	P	TPI	TPI _{max}	E	f	a	d	s	D _{min}	HIS	EG55
RS116.0510.GM1	1	18	32	4.1	10.2	15.7	11	5.2	16	116110R	▲
RS116.0815.GM1	1.5	12	20	4.1	10.2	15.7	11	5.2	16	116110R	▲
RS116.1020.GM1	2	11	16	4.1	10.2	15.7	11	5.2	16	116110R	▲
RS116.1325.GM1	2.5	9	12	4.1	10.2	15.7	11	5.2	16	116110R	▲
LS116.0510.GM1	1	18	32	4.1	10.2	15.7	11	5.2	16	116110L	▲
LS116.0815.GM1	1.5	12	20	4.1	10.2	15.7	11	5.2	16	116110L	▲
LS116.1020.GM1	2	11	16	4.1	10.2	15.7	11	5.2	16	116110L	▲
LS116.1325.GM1	2.5	9	12	4.1	10.2	15.7	11	5.2	16	116110L	▲

Dimensions in mm

P	●
M	●
K	●
N	-
S	-
H	-

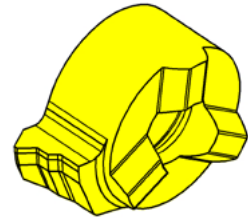
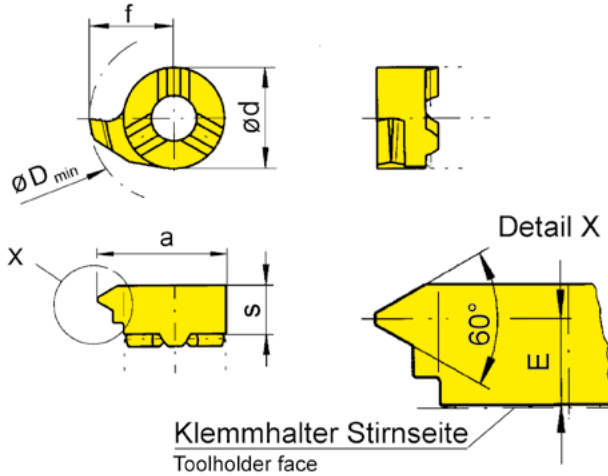

Coating grades

R = right hand version shown

L = left hand version

▲ In stock

Δ 2 weeks

Part number	P	E	f	a	d	s	D _{min}	HIS	Coating grades		
									EG55	TI25	TN35
R116.0510.02	1	4.7	10.2	15.7	11	5.5	16	116110R	▲		▲
R116.0815.02	1.5	4.5	10.2	15.7	11	5.5	16	116110R	▲		▲
R116.1020.02	2	4.3	10.2	15.7	11	5.5	16	116110R	▲		▲
R116.1325.02	2.5	4.2	10.2	15.7	11	5.5	16	116110R	▲		▲
R116.1630.02	3	4	10.2	15.7	11	5.5	16	116110R	▲		▲
R116.1835.02	3.5	3.8	10.2	15.7	11	5.5	16	116110R	▲		▲
R116.2140.02	4	3.6	10.2	15.7	11	5.5	16	116110R	▲		▲
L116.0510.02	1	4.7	10.2	15.7	11	5.5	16	116110L	▲		Δ
L116.0815.02	1.5	4.5	10.2	15.7	11	5.5	16	116110L	Δ		▲
L116.1020.02	2	4.3	10.2	15.7	11	5.5	16	116110L	Δ		▲
L116.1325.02	2.5	4.2	10.2	15.7	11	5.5	16	116110L	Δ	Δ	▲
L116.1630.02	3	4	10.2	15.7	11	5.5	16	116110L	▲		▲
L116.1835.02	3.5	3.8	10.2	15.7	11	5.5	16	116110L	Δ		▲
L116.2140.02	4	3.6	10.2	15.7	11	5.5	16	116110L	Δ		▲

Dimensions in mm

P	●	●	●
M	●	●	-
K	●	-	●
N	-	●	○
S	-	-	-
H	-	-	-

K

Insert

S116 $\varnothing \geq 16$ mm

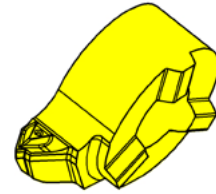
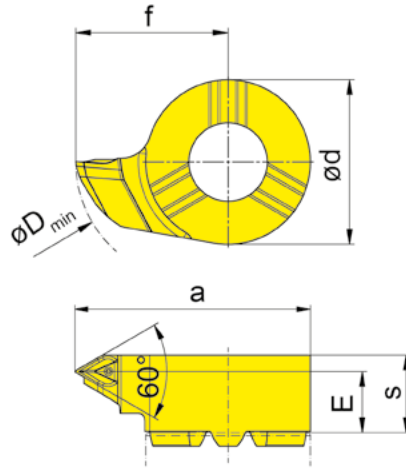

Coating grades

R = right hand version shown

L = left hand version

▲ In stock

Δ 2 weeks

Part number	P	E	f	a	d	s	D _{min}	HIS	EG55
RS116.0510.GM2	1	4.1	10.2	15.7	11	5.2	16	116110R	▲
RS116.0815.GM2	1.5	4.1	10.2	15.7	11	5.2	16	116110R	▲
RS116.1020.GM2	2	4.1	10.2	15.7	11	5.2	16	116110R	▲
RS116.1325.GM2	2.5	4.1	10.2	15.7	11	5.2	16	116110R	▲
LS116.0510.GM2	1	4.1	10.2	15.7	11	5.2	16	116110L	▲
LS116.0815.GM2	1.5	4.1	10.2	15.7	11	5.2	16	116110L	▲
LS116.1020.GM2	2	4.1	10.2	15.7	11	5.2	16	116110L	▲
LS116.1325.GM2	2.5	4.1	10.2	15.7	11	5.2	16	116110L	▲

Dimensions in mm

P	●
M	●
K	●
N	-
S	-
H	-

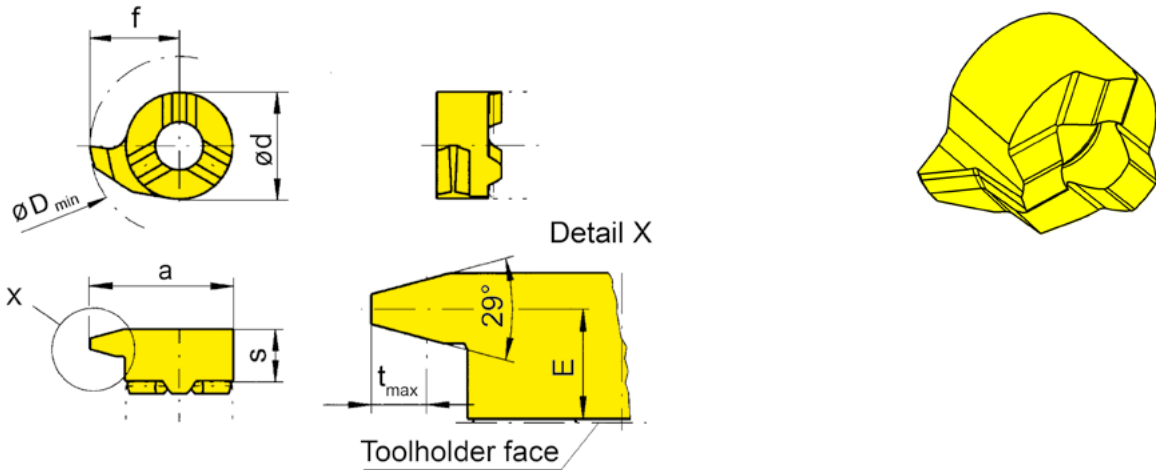

Coating grades

R = right hand version shown

L = left hand version

▲ In stock

Δ 2 weeks

Part number	TPI	E	f	a	d	s	t _{max}	D _{min}	HIS	Coating grades		
										IG35	TH35	TN35
RU116.AC04.01	4	.130	.402	.618	.433	.217	.135	.630	116110R	▲	▲	▲
RU116.AC05.01	5	.146	.402	.618	.433	.217	.110	.630	116110R	▲	▲	▲
RU116.SA03.01	3	.150	.402	.618	.433	.256	.110	.630	116110R	▲	▲	▲
RU116.SA04.01	4	.138	.402	.618	.433	.217	.085	.630	116110R	▲	▲	▲
RU116.SA05.01	5	.150	.402	.079	.433	.217	.070	.630	116110R	▲	▲	▲
RU116.SA06.01	6	.157	.382	.065	.433	.217	.060	.630	116110R	▲	▲	▲
LU116.AC04.01	4	.130	.402	.618	.433	.217	.135	.630	116110L	▲		▲
LU116.AC05.01	5	.146	.402	.618	.433	.217	.110	.630	116110L	▲		▲
LU116.SA05.01	5	.150	.402	.079	.433	.217	.070	.630	116110L	▲		▲
LU116.SA06.01	6	.157	.382	.065	.433	.217	.060	.630	116110L			Δ

Inserts with ".AC" are designed for standard ACME threads. Inserts with ".SA" are designed for stub ACME threads.

Dimensions in inch



P	●	●	●
M	●	●	-
K	●	●	●
N	○	-	○
S	○	-	-
H	-	-	-

K

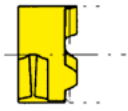
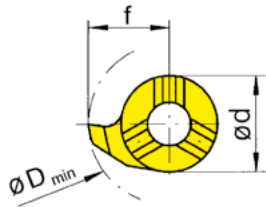

Detail X

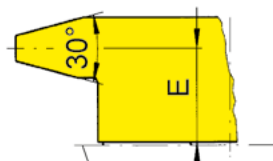
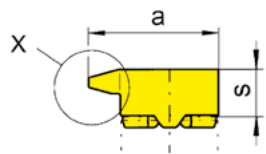

Klemmhalter Stirnseite
Toolholder face

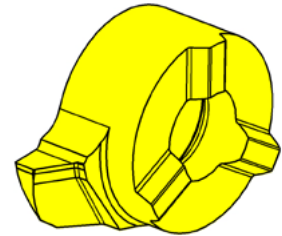

Coating grades

R = right hand version shown

L = left hand version

▲ In stock

△ 2 weeks

Part number	P	E	f	a	d	s	D _{min}	Thread	HIS	Coating grades		
										EG55	TI25	TN35
R116.1220.01	2	4.5	9.7	15.2	11	5.5	16	Tr 20x2	116110R	▲		▲
R116.1730.01	3	4.3	9.7	15.2	11	5.5	16	Tr 22x3	116110R	▲		▲
R116.2240.01	4	4	9.7	15.2	11	5.5	16	Tr 22x4	116110R	▲		▲
R116.2750.01	5	3.55	10.2	15.7	11	5.5	16	Tr 24x5	116110R	▲		▲
R116.3560.01	6	3.3	10.2	15.7	11	5.5	16	Tr 30x6	116110R	▲	▲	
L116.1220.01	2	4.5	9.7	15.2	11	5.5	16	Tr 20x2	116110L	△		△
L116.1730.01	3	4.3	9.7	15.2	11	5.5	16	Tr 22x3	116110L	▲		▲
L116.2240.01	4	4	9.7	15.2	11	5.5	16	Tr 22x4	116110L	▲		▲
L116.2750.01	5	3.55	10.2	15.7	11	5.5	16	Tr 24x5	116110L	▲		▲
L116.3560.01	6	3.3	10.2	15.7	11	5.5	16	Tr 30x6	116110L	▲	▲	

These inserts produce a trapezoidal thread profile

Dimensions in mm

P	●	●	●
M	●	●	-
K	●	-	●
N	-	●	○
S	-	-	-
H	-	-	-

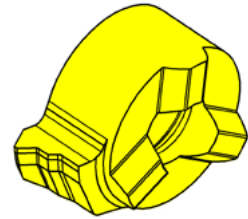
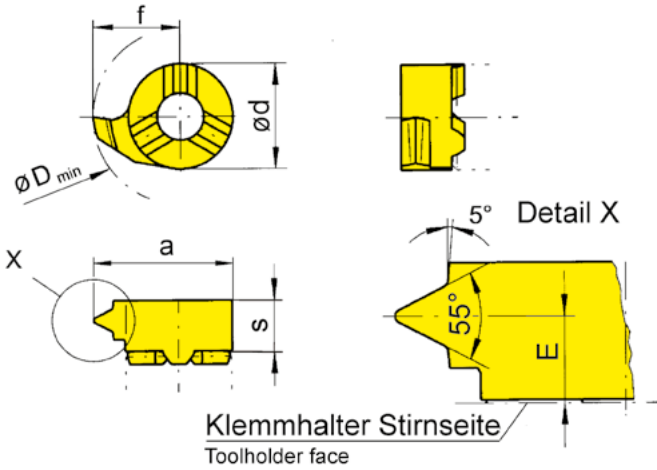

Coating grades

R = right hand version shown

L = left hand version

▲ In stock

△ 2 weeks

Part number	TPI	E	f	d	s	D _{min}	HIS	EG55	TN35
R116.5511.02	11	3.5	10.2	11	5.5	16	116110R	▲	▲
R116.5514.02	14	3.9	10.2	11	5.5	16	116110R	▲	▲
L116.5511.02	11	3.5	10.2	11	5.5	16	116110L	△	▲
L116.5514.02	14	3.9	10.2	11	5.5	16	116110L	△	▲

Dimensions in mm

P	●	●
M	●	-
K	●	●
N	-	○
S	-	-
H	-	-

NEED SPECIAL TOOLS?



Scan or click

SCAN THE QR CODE ABOVE TO LEARN MORE ABOUT OUR SPECIAL PRODUCTS

Eligible US specials in 5 days with Greenline.

Available for all specialized applications.

Designed by machinists, for machinists.





MINI 18P

L

Bore Ø		Tool System											
mm	in	105	109	110	106	107	108	10P	111	11P	114	116	18P
≥ 0.2	≥ .0079	•											
≥ 0.5	≥ .0197	•											
≥ 0.7	≥ .0276	•											
≥ 1.0	≥ .0394	•											
≥ 1.5	≥ .0591	•											
≥ 2.0	≥ .0787	•											
≥ 3.0	≥ .1181	•											
≥ 4.0	≥ .1575	•											
≥ 5.0	≥ .1969	•											
≥ 6.0	≥ .2362	•	•	•	•								
≥ 6.8	≥ .2677		•	•	•								
≥ 7.0	≥ .2756		•			•							
≥ 7.8	≥ .3071			•		•	•						
≥ 8.0	≥ .3150			•		•	•						
≥ 9.0	≥ .3543			•		•	•	•					
≥ 10.0	≥ .3937			•				•	•	•			
≥ 10.5	≥ .4134									•			
≥ 11.0	≥ .4331								•	•			
≥ 11.5	≥ .4528									•			
≥ 13.8	≥ .5433										•		
≥ 14.0	≥ .5512										•	•	
≥ 16.0	≥ .6299									•		•	
≥ 16.5	≥ .6496										[•]		
≥ 18.0	≥ .7087												•
Depth of groove	mm	2.5	2.5	4.0	0.8	2.0	1.0	3.0	2.3	3.5	4.0, [6.5]	4.3	8.0
	in	.0984	.0984	.1575	.0315	.0787	.0394	.1181	.0906	.1378	.1575, [.2559]	.1693	.3150
Width of groove	mm	0.5-2.0	1.0-2.0	1.0-3.0	0.7-1.5	1.0-2.0	0.7-2.0	1.0-3.0	0.7-3.0	1.0-3.0	0.7-3.0	0.7-4.0	2.0-3.0
	in	.0197-.0787	.0394-.0787	.0394-.1181	.0276-.0591	.0394-.0787	.0276-.0787	.0394-.1181	.0276-.1181	.0394-.1181	.0276-.1181	.0276-.1575	.0787-.1181
Operations													
Grooving		•	•	•	•	•	•	•	•	•	•	•	•
Boring		•	•	•	•	•	•		•		•	•	
Threading		•	•			•	•		•		•	•	
Chamfering		•	•			•	•		•		•	•	
Face Grooving		•	•	•							•		
Boring and Profiling		•					•	•	•	•	•	•	

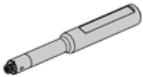
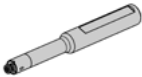

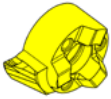
HOLDERS	Round Shank	
	 Page 429 Holder BU18P Inch Shank	 Page 430 Holder B18P

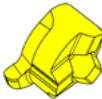
INSERTS	Boring	Grooving	
	 Page 431 Bore Contouring .R Chipbreaker	 Page 432-433 Grooving .D Chipbreaker	 Page 434 Grooving Full Radius

Cutting Data and Technical Instructions - Chapter M / Page 436



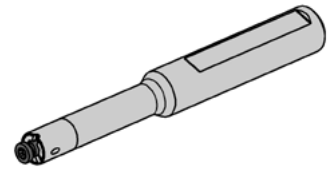
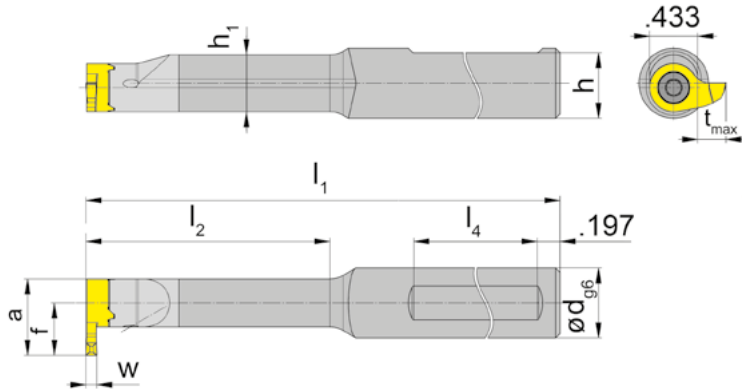
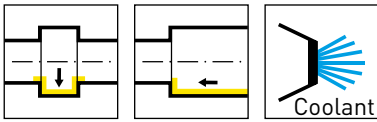

R = right hand version shown

L = left hand version

Part number	d	l ₁	l ₂	h	l ₄	h ₁	HWS
RB U18P.0500.00	.500	3.937	.984	.461	1.969	.500	18P110R
RB U18P.0500.01	.500	4.724	1.575	.461	1.969	.500	18P110R
RB U18P.0625.00	.625	3.937	.984	.585	1.969	.512	18P110R
RB U18P.0625.01	.625	4.724	1.575	.585	1.969	.512	18P110R
RB U18P.0625.02	.625	5.118	2.205	.585	1.969	.512	18P110R
RB U18P.0625.03	.625	5.906	3.150	.585	1.969	.512	18P110R
LB U18P.0500.00	.500	3.937	.984	.461	1.969	.500	18P110L
LB U18P.0500.01	.500	4.724	1.575	.461	1.969	.500	18P110L
LB U18P.0625.00	.625	3.937	.984	.585	1.969	.512	18P110L
LB U18P.0625.01	.625	4.724	1.575	.585	1.969	.512	18P110L
LB U18P.0625.02	.625	5.118	2.205	.585	1.969	.512	18P110L
LB U18P.0625.03	.625	5.906	3.150	.585	1.969	.512	18P110L

For w, a, tmax and f dimensions, see insert pages

Dimensions in inch



L

Spare Parts

Toolholder	Clamping Screw	TORX PLUS® Wrench	Torque Value
R/LBU18P...	5.13T20EP	T20PQ	6 Nm

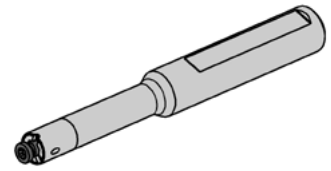
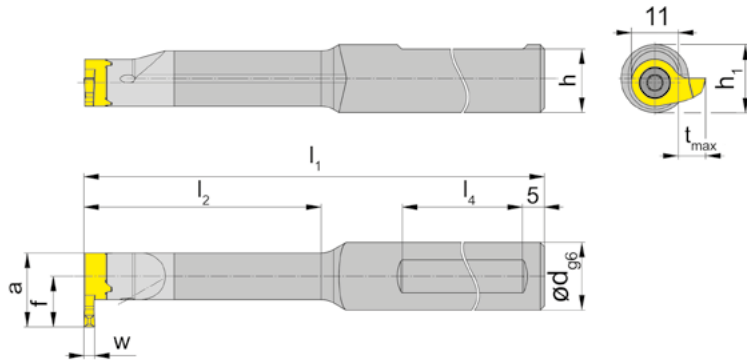
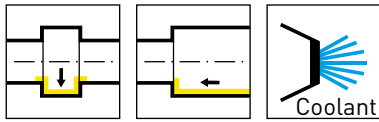

R = right hand version shown

L = left hand version

Part number	d	l ₁	l ₂	h	l ₄	h ₁	HWS
RB18P.0012.00	12	100	25	11	50	12.5	18P110R
RB18P.0012.01	12	120	40	11	50	12.5	18P110R
RB18P.0016.00	16	100	25	15	50	13	18P110R
RB18P.0016.01	16	120	40	15	50	13	18P110R
RB18P.0016.02	16	130	56	15	50	13	18P110R
RB18P.0016.03	16	150	80	15	50	13	18P110R
LB18P.0012.00	12	100	25	11	50	12.5	18P110L
LB18P.0012.01	12	120	40	11	50	12.5	18P110L
LB18P.0016.00	16	100	25	15	50	13	18P110L
LB18P.0016.01	16	120	40	15	50	13	18P110L
LB18P.0016.02	16	130	56	15	50	13	18P110L
LB18P.0016.03	16	150	80	15	50	13	18P110L

For w, a, tmax and f dimensions, see insert pages

Dimensions in mm

Spare Parts

Toolholder	Clamping Screw	TORX PLUS® Wrench	Torque Value
R/LB18P...	5.13T20EP	T20PQ	6 Nm



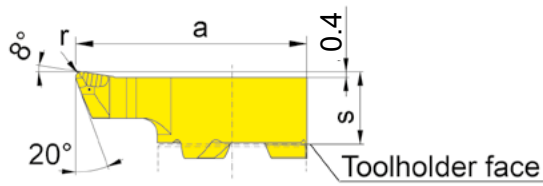
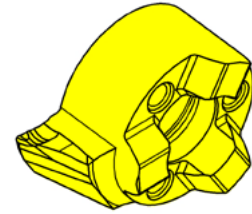
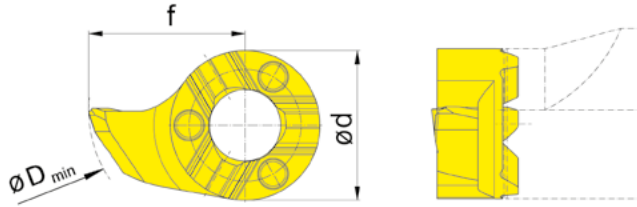
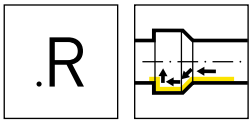

Coating grades

R = right hand version shown

L = left hand version

▲ In stock

△ 2 weeks

Part number	s	f	a	r	d	D _{min}	HIS	EG55	TH35
RS18P.1815.R2	5.3	11.5	17	0.2	11	17.5	18P110R	△	▲
RS18P.1815.R4	5.3	11.5	17	0.4	11	17.5	18P110R	▲	▲
LS18P.1815.R2	5.3	11.5	17	0.2	11	17.5	18P110L	△	▲
LS18P.1815.R4	5.3	11.5	17	0.4	11	17.5	18P110L	▲	▲

Dimensions in mm

P	●	●
M	●	●
K	●	●
N	-	-
S	-	-
H	-	-

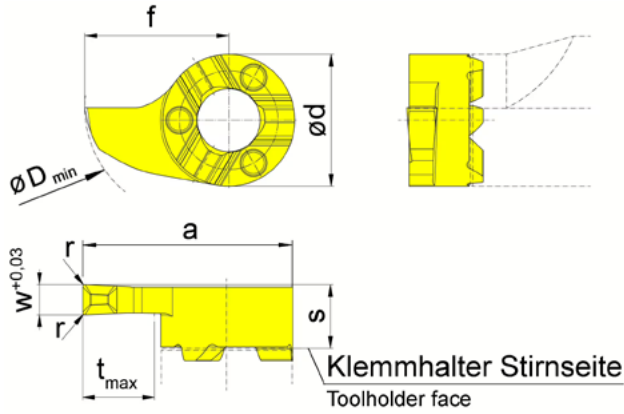
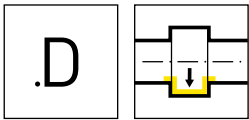

Coating grades

R = right hand version shown

L = left hand version

▲ In stock

Δ 2 weeks

Part number	w	s	f	a	r	d	t _{max}	D _{min}	HIS	EG55	TH35
RS18P.0200.1.D2	2	5.3	12	17.5	0.2	11	6	18	18P110R	▲	▲
RS18P.0250.1.D2	2.5	5.3	12	17.5	0.2	11	6	18	18P110R	▲	▲
RS18P.0300.1.D2	3	5.3	12	17.5	0.2	11	6	18	18P110R	▲	▲
LS18P.0200.1.D2	2	5.3	12	17.5	0.2	11	6	18	18P110L	▲	▲
LS18P.0250.1.D2	2.5	5.3	12	17.5	0.2	11	6	18	18P110L	▲	▲
LS18P.0300.1.D2	3	5.3	12	17.5	0.2	11	6	18	18P110L	▲	▲

Dimensions in mm

P	●	●
M	●	●
K	●	●
N	-	-
S	-	-
H	-	-



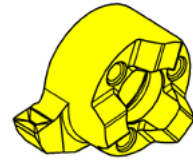
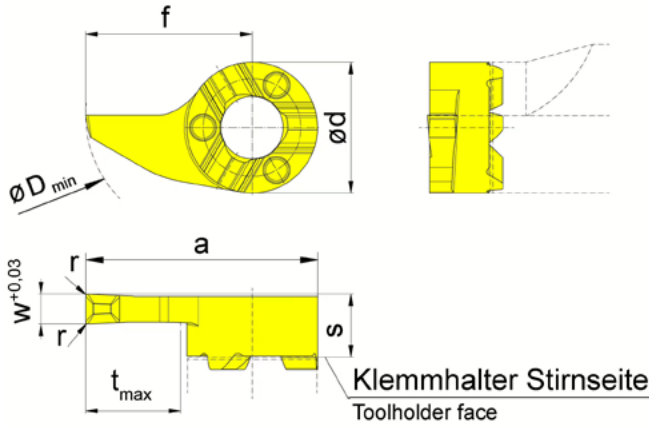
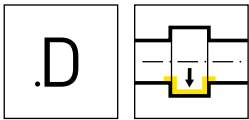

Coating grades

R = right hand version shown

L = left hand version

▲ In stock

△ 2 weeks

Part number	w	s	f	a	r	d	t _{max}	D _{min}	HIS	EG55	TH35
RS18P.0200.2.D2	2	5.3	14	19.5	0.2	11	8	20	18P110R	▲	▲
RS18P.0250.2.D2	2.5	5.3	14	19.5	0.2	11	8	20	18P110R	▲	▲
RS18P.0300.2.D2	3	5.3	14	19.5	0.2	11	8	20	18P110R	▲	▲
LS18P.0200.2.D2	2	5.3	14	19.5	0.2	11	8	20	18P110L	▲	▲
LS18P.0250.2.D2	2.5	5.3	14	19.5	0.2	11	8	20	18P110L	△	▲
LS18P.0300.2.D2	3	5.3	14	19.5	0.2	11	8	20	18P110L	▲	▲

Dimensions in mm

P	●	●
M	●	●
K	●	●
N	-	-
S	-	-
H	-	-

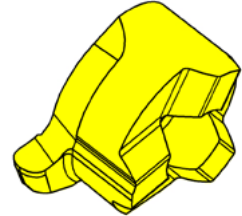
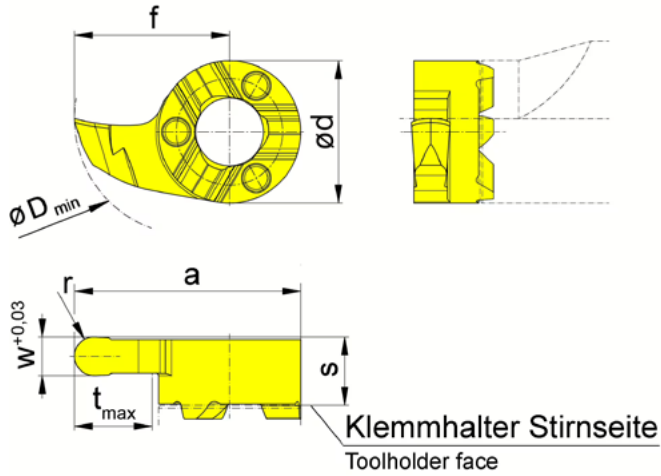
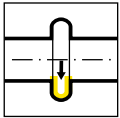

Coating grades

R = right hand version shown

L = left hand version

▲ In stock

△ 2 weeks

Part number	w	s	f	a	r	d	t _{max}	D _{min}	HIS	EG55	TH35
R18P.0009.1.18	1.8	5.3	12	17.5	0.9	11	6	18	18P110R	▲	▲
R18P.0011.1.22	2.2	5.3	12	17.5	1.1	11	6	18	18P110R	▲	▲
R18P.0015.1.30	3	5.3	12	17.5	1.5	11	6	18	18P110R	▲	▲
L18P.0009.1.18	1.8	5.3	12	17.5	0.9	11	6	18	18P110L	△	▲
L18P.0011.1.22	2.2	5.3	12	17.5	1.1	11	6	18	18P110L	△	▲
L18P.0015.1.30	3	5.3	12	17.5	1.5	11	6	18	18P110L	▲	▲

Dimensions in mm

P	●	●
M	●	●
K	●	●
N	-	-
S	-	-
H	-	-



HORN TOOL SELECTOR



Scan or click

QUICKLY FIND THE RIGHT TOOLS FOR YOUR JOB

Select your tools with confidence.

Easily filter based on process, material, and parameters.

Spend less time searching and more time machining.



Section	Page
Coating Overview	437-438
Cutting Data	439-444
Geometries and Feed Rates	445-446
Cutting Data and Geometries for 105.B0	447-448
Threading Technical Information	449-451
Machining Examples	452-455
Torque Values	456
Torque Wrenches and Drivers	457-462

IG35				
<div style="display: flex; justify-content: space-around; align-items: center;"> <div style="text-align: center;"> Chemical composition </div> <div style="text-align: center;"> Coating thickness </div> <div style="text-align: center;"> Carbide substrate </div> </div>				
Coating	Appearance	Material	Recommendation	Application
TH3_		TiAlN	Best: <div style="display: flex; justify-content: center; gap: 10px;"> <div style="background-color: blue; color: white; padding: 5px 10px; border: 1px solid black;">P</div> <div style="background-color: yellow; color: black; padding: 5px 10px; border: 1px solid black;">M</div> <div style="background-color: red; color: white; padding: 5px 10px; border: 1px solid black;">K</div> </div>	For medium feeds and interrupted cuts
EG3_		AlTiN + TiN	Best: Secondary: <div style="display: flex; justify-content: center; gap: 10px;"> <div style="background-color: blue; color: white; padding: 5px 10px; border: 1px solid black;">P</div> <div style="background-color: yellow; color: black; padding: 5px 10px; border: 1px solid black;">M</div> <div style="background-color: red; color: white; padding: 5px 10px; border: 1px solid black;">K</div> <div style="background-color: lightgreen; color: black; padding: 5px 10px; border: 1px solid black;">N</div> </div>	For small and medium feed rates, in addition to finishing without interrupted cuts
EG5_		AlTiN + TiN	Best: <div style="display: flex; justify-content: center; gap: 10px;"> <div style="background-color: blue; color: white; padding: 5px 10px; border: 1px solid black;">P</div> <div style="background-color: yellow; color: black; padding: 5px 10px; border: 1px solid black;">M</div> <div style="background-color: red; color: white; padding: 5px 10px; border: 1px solid black;">K</div> </div>	For medium feed rates and interrupted cuts
ES1_		AlTiN	Best: Secondary: <div style="display: flex; justify-content: center; gap: 10px;"> <div style="background-color: blue; color: white; padding: 5px 10px; border: 1px solid black;">P</div> <div style="background-color: yellow; color: black; padding: 5px 10px; border: 1px solid black;">M</div> <div style="background-color: lightgreen; color: black; padding: 5px 10px; border: 1px solid black;">N</div> <div style="background-color: orange; color: black; padding: 5px 10px; border: 1px solid black;">S</div> </div>	For finishing and small feed rates without cutting interruptions
IG3_		TiAlSiN	Best: Secondary: <div style="display: flex; justify-content: center; gap: 10px;"> <div style="background-color: blue; color: white; padding: 5px 10px; border: 1px solid black;">P</div> <div style="background-color: yellow; color: black; padding: 5px 10px; border: 1px solid black;">M</div> <div style="background-color: red; color: white; padding: 5px 10px; border: 1px solid black;">K</div> <div style="background-color: lightgreen; color: black; padding: 5px 10px; border: 1px solid black;">N</div> <div style="background-color: orange; color: black; padding: 5px 10px; border: 1px solid black;">S</div> </div>	For high cutting speeds without cutting interruptions
MG12		Uncoated	Best: <div style="display: flex; justify-content: center; gap: 10px;"> <div style="background-color: lightgreen; color: black; padding: 5px 10px; border: 1px solid black;">N</div> </div>	For roughing and finishing at low cutting speeds

Coating	Appearance	Material	Recommendation	Application
SG3_		TiAlCrSiN	Best: S H Secondary: P M	For small and medium feeds, in addition to finishing without interrupted cuts
Ti2_		TiCN	Best: P M N	For small and medium feeds at low cutting speeds, prevents reduction of built-up edges
TN3_		TiN	Best: P K Secondary: N	For low cutting speeds and interrupted cuts

ISO Material Group	P	M	K	N	S	H
	Mild, Carbon, Alloyed, Cast, Sintered Steels	Stainless Steels	Grey, Spheroidal Graphite, Malleable Cast Irons	Non-Ferrous, Al-Alloys, Cu-Alloys, Graphite	Heat resistant, Super alloys, Titanium	Hardened Steels
First choice	EG35/55 AlTiN + TiN	IG35 TiAlSiN	IG35 TiAlSiN	MG12 Uncoated	IG35 TiAlSiN	SG36 TiAlCrSiN
Second	IG35 TiAlSiN	SG36 TiAlCrSiN	TH35 TiAlN	Ti25 TiCN	SG36 TiAlCrSiN	
Third	SG36 TiAlCrSiN	Ti25 TiCN	EG35/55 AlTiN + TiN	ES15 AlTiN	ES15 AlTiN	

Material		Material group	Hardness Brinell (HB)	Tensile Strength R_m [N/mm ²]	Example Material SAE, DIN		
P	Carbon steel	~ 0,2 % C	P1.1	125	430	1015 , CK15	
		~ 0,4% C annealed	P1.2	190	610	A515 , 19Mn6	
		~ 0,4% C quenched	P1.3	210	640	1335 , 36Mn5	
		~ 0,6% C annealed	P1.4	190	610	1055 , C55	
		~ 0,6% C quenched	P1.5	300	1000	1060 , CK60	
		Free cutting steel	P1.6	220	750	1213 , 9SMn28	
	Alloyed steel (<5%)	annealed	P2.1	180	590	52100 , 100Cr6	
		quenched	P2.2	280	960	3415 , 14NiCr10	
		quenched	P2.3	350	1250	4135 , 34CrMo4	
		quenched	P2.4	430	1450	5155 , 55Cr3	
	high alloyed steel (>5%)	annealed	P3.1	200	680	442 , X10CrAl18	
		hardened	P3.2	350	1200	D3 , X210Cr2	
	Cast steel	unalloyed	P4.1	180	590	A27 , GE200	
		alloyed	P4.2	220	750	10295 , GX40CrSi28	
	Sintered steel	soft	P5.1	220	570	P3082 , Sint-D39	
	M	Stainless steel	martensitic ferritic	M1.1	200	680	17-4 PH , 455 , 465 , X16Cr13
			austenitic	M1.2	300	1000	316Ti , X6CrNiMo-Ti17-12-2
			austenitic ferritic	M1.3	230	780	316LN , X2CrNiMo-N17-13-3

Cutting Data



	MG12		=	Coating Grade						Coating Grades
	55-395 16-120			Cutting speed Vc (SFM) - Suggested range Cutting speed Vc (m/min) - Suggested range						
	MG12	TN3_	TI2_	TH3_ TF4_	AN2_ RC2_	EG3_ EG5_	IG3_	DD2_	SG3_	
Carbon steel	55-395 16-120	55-590 16-180	55-590 16-180	55-690 16-210	55-690 16-210	55-655 16-200	55-720 16-230		55-755 16-230	
	55-360 16-110	55-560 16-170	55-560 16-170	55-655 16-200	55-655 16-200	55-655 16-200	55-720 16-230		55-755 16-230	
	55-360 16-110	55-525 16-160	55-525 16-160	55-625 16-190	55-625 16-190	55-625 16-190	55-720 16-220		55-720 16-220	
	55-360 16-110	55-490 16-150	55-490 16-150	55-590 16-180	55-590 16-180	55-590 16-180	55-690 16-210		55-690 16-210	
	55-330 16-100	55-395 16-120	55-460 16-140	55-560 16-170	55-560 16-170	55-560 16-170	55-655 16-200		55-655 16-200	
	55-395 16-120	16-525 16-160	55-525 16-160	55-625 16-190	55-625 16-190	55-625 16-190	55-720 16-220		55-720 16-220	
Alloyed steel (<5%)	55-295 16-90	55-490 16-150	55-490 16-150	55-590 16-180	55-590 16-180	55-590 16-180	55-690 16-210		55-690 16-210	
	55-280 16-85	55-460 16-140	55-460 16-140	55-590 16-180	55-590 16-180	55-590 16-180	55-690 16-210		55-690 16-210	
	55-260 16-80	55-460 16-140	55-460 16-140	55-590 16-180	55-590 16-180	55-590 16-180	55-690 16-210		55-690 16-210	
	55-260 16-80	55-460 16-140	55-460 16-140	55-525 16-160	55-525 16-160	55-525 16-160	55-590 16-180		55-590 16-180	
High alloy steel (>5%)	55-295 16-90	55-295 16-90	55-295 16-90	55-460 16-140	55-460 16-140	55-395 16-120	55-460 16-140		55-460 16-140	
									55-460 16-140	
Cast steel	55-360 16-110	55-590 16-180	55-590 16-180	55-590 16-180	55-590 16-180	55-525 16-160	55-590 16-180		55-590 16-180	
	55-230 16-70	55-560 16-170		55-590 16-180	55-590 16-180	55-525 16-160	55-590 16-180		55-590 16-180	
Sintered steel										
Stainless steel		55-295 16 - 90		60-295 19 - 90	55-295 16 - 90	55-295 16 - 90	50-330 15 - 100		55-330 16 - 100	
		55-260 16 - 80		55-260 16 - 80	55-260 16 - 80	55-260 16 - 80	55-260 16 - 80		55-130 16 - 40	
		55-195 16-60		55-195 16-60	55-195 16-60	55-195 16-60	55-230 16-70		55-260 16-80	

Material		Material group	Hardness Brinell (HB)	Tensile Strength R_m [N/mm ²]	Example Material SAE, DIN	
K	Grey cast iron	low tensile strength	K1.1	180	250	A48 Class 35B , GG-25
		high tensile strength	K1.2	250	350	A48 Class 60 , GG-40
	Spheroidal graphite cast iron	ferritic	K2.1	160	400	A536 60-40-18 , GGG-40
		perlitic	K2.2	260	700	A536 80-60-03 , GGG-60
	Malleable cast iron	ferritic	K3.1	200	400	A47 Grade 35018 , GTW-45
		perlitic	K3.2	260	700	A47 Grade 55004 , GTS-55-04
	Ausferritic spheroidal cast iron / ADI	quenched	K4.1	260	800	
		quenched	K4.2	350	1050	
		quenched	K4.3	450	1400	
	N	Al-alloys	not heat treatable	N1.1	30	
heat treatable			N1.2	100	340	6061, 7075 , AlMgSi1
Al-cast-alloy		< 6% Si	N2.1	80	300	AA 441 , AlMgSi6
		6-10% Si	N2.2	100	320	AA 356 , AlSi7Mg
		10-15 % Si	N2.3	130	450	AA 413 , AlSi12
Copper-alloys		pure copper	N3.1	100	340	C11000 , Cu
		brass	N3.2	90	310	C38500 , CuZn40Pb
		lead-free brass	N3.3	110	430	C28000 , CuZn40
		high strength	N3.4	300	1000	C67800 , CuZn25Al5-Mn4Fe3
Graphite			N4.1			

Cutting Data



	MG12		=	Coating Grade						Coating Grades
	55-395 16-120			Cutting speed Vc (SFM) - Suggested range Cutting speed Vc (m/min) - Suggested range						
	MG12	TN3_	TI2_	TH3_ TF4_	AN2_ RC2_	EG3_ EG5_	IG3_	DD2_	SG3_	
Grey cast iron	55-295 16 - 90	55-490 16 - 150		55-525 16 - 160		55-525 16 - 160				
		55-395 16 - 120								
Spheroidal graphite cast iron	55-295 16 - 90	55-425 16 - 130								
		55-330 16-100		55-525 18 - 160		55-460 16 - 140				
Malleable cast iron		55-425 16 - 130		55-590 16 - 180		55-525 18 - 160				
Ausferritic spheroidal cast iron / ADI										
Al-alloys	55-720 16 - 220		55-720 16 - 220	55-720 16 - 220		55-720 16 - 220		55-1150 16 -350		
	55-720 16 - 220		55-720 16 - 220	55-720 16 - 220		55-720 16 - 220		55-1150 16 -350		
Al-cast-alloy	55-720 16 - 220		55-720 16 - 220	55-720 16 - 220		55-720 16 - 220		55-1150 16 -350		
								55-1150 16-350		
Copper-alloys	55-720 16 - 220							55-985 16 -300		
	55-720 16 - 220							55-985 16 -300		
	55-720 16 - 220							55-820 16 -250		
	55-590 16 - 180							55-655 16 -200		
Graphite										

Material		Material group	Hardness Brinell (HB)	Tensile Strength R_m [N/mm ²]	Example Material SAE, DIN	
S	Heat resistant alloy	annealed	S1.1	200	670	
		hardened	S1.2	275	930	
	Heat resistant alloy	annealed	S2.1	250	840	Inconel 600
		hardened	S2.2	350	1200	Inconel 713
	Titanium	Titanium alloy α	S3.1	120	240	Grade 1-2 Ti, Ti99,7
		Titanium alloy α - β	S3.2	360	1200	Grade 5 Ti, Ti6Al4V
		Titanium alloy β	S3.3	410	1400	Ti-10-2-3, Ti-10V-2Fe-3Al
H	Hardened steels	50-55 HRC	H1.1			
		55-60 HRC	H1.2			
		60-63 HRC	H1.3			
		> 63HRC	H1.4			
O	Thermoplastics		O1.1			
	Duro plaste		O1.2			
	Plastics - glass fiber reinforced	GFK	O1.3			
	Plastics - carbon fiber reinforced	CFK	O1.4			











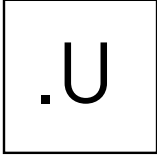

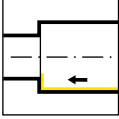
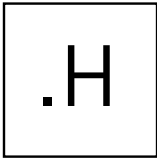
Cutting Data

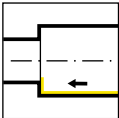
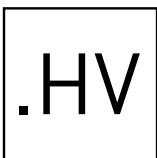

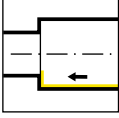
		MG12	Coating Grade								
		55-395 16-120	=	Cutting speed Vc (SFM) - Suggested range							
				Cutting speed Vc (m/min) - Suggested range							
	MG12	TN3_	TI2_	TH3_ TF4_	AN2_ RC2_	EG3_ EG5_	IG3_	DD2_	SG3_	Coating Grades	
Heat resistant alloy	55-165 16-50						55-250 16-75		55-250 16-75		
	55-165 16-50										
Heat resistant alloy	55-100 16-30						55-130 16-40		55-130 16-40		
	55-100 16-30						55-130 16-40		55-130 16-40		
Titanium	55-100 16-30						55-250 16-75		55-280 16-85		
	55-100 16-30						55-250 16-75		55-280 16-85		
	55-100 16-30						55-250 16-75		55-280 16-85		
Hardened steels							55-165 16-50		55-200 16-60		
							55-165 16-50		55-200 16-60		
Thermoplastics	55-490 16-150										
Duro plaste	55-490 16-150										
Plastics - glass fiber reinforced	55-490 16-150										
Plastics - carbon fiber reinforced	55-985 16-300										

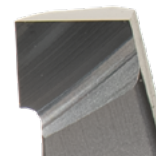
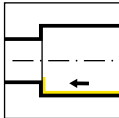
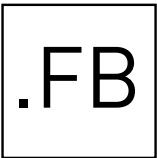
Geometries and Feed Rates - Supermini

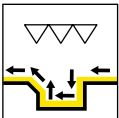

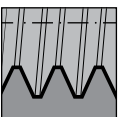
Geometry/Chipbreaker		Material Group	Feed Rate, Depth of Cut Direction of cut	Operation
 Sintered, all-purpose		P M K N S H	f = .0012-.0028 in/rev f = 0.03-0.07 mm/rev ap = .0040-.0160 in ap = 0.1-0.4 mm ←	 Boring
 Ground, tighter chips		P M K N S H	f = .0016-.0024 in/rev f = 0.04-0.06 mm/rev ap = .006-.020 in ap = 0.15-0.5 mm ←	 Boring
 Ground, larger chips		P M K N S H	f = .002-.004 in/rev f = 0.05-0.1 mm/rev ap = .006-.020 in ap = 0.15-0.5 mm ←	 Boring
 Ground, super finishing		P M K N S H	f = .0001-.0016 in/rev f = 0.003-0.04 mm/rev ap = .0002-.004 in ap = 0.005-0.1 mm ←	 Boring
 Ground, fine finishing		P M K N S H	f = .0004-.0016 in/rev f = 0.01-0.04 mm/rev ap = .0012-.0020 in ap = 0.03-0.05 mm ↓ ↔	 Fine Finishing
 Sintered, all-purpose		P M K N S H	ap = .001-.004 in* ap = 0.03 - 0.1mm* ↓ *see Technical Information - Threading on page 450 for expanded recommendations	 Threading

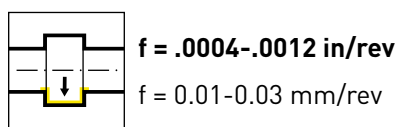

Grooving

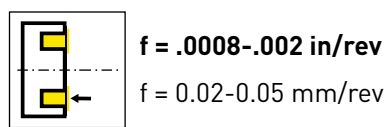

Face Grooving

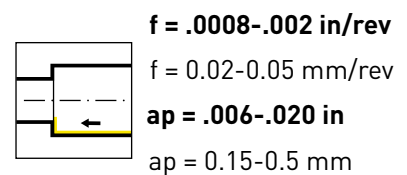







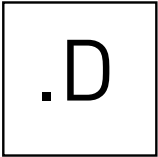

Internal Boring

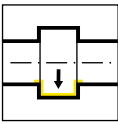
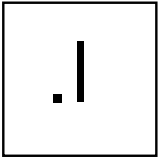
 Recommended	 P Carbon Steels	 M Stainless Steels	 K Cast Irons
 Secondary	 N Non-Ferrous	 S Super Alloys	 H Hardened Steels

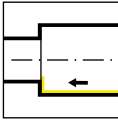
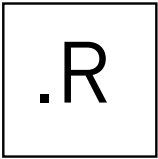
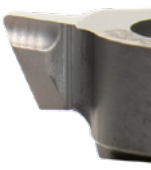
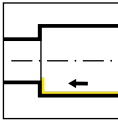
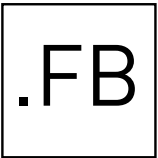
Geometries and Feed Rates - Mini

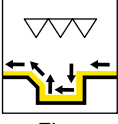

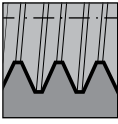
Geometry/Chipbreaker		Material Group	Feed Rate, Depth of Cut Direction of cut	Operation
 Sintered, all-purpose		P M K N S H	↓ ↔ f = .0012-.0032 in/rev f = 0.03-0.08 mm/rev ap = .0080-.0600 in* ap = 0.2-1.5 mm* *tool group dependent	 Grooving
 Sintered, best for boring		P M K N S H	← f = .0020-.0060 in/rev f = 0.05-0.15 mm/rev ap = .0020-.0250 in ap = 0.05-0.6 mm	 Boring
 Sintered, best for contouring		P M K N S H	← f = .0020-.0060 in/rev f = 0.05-0.15 mm/rev ap = .0080-.0800 in* ap = 0.2-2.0 mm* *tool group dependent	 Boring
 Ground, fine finishing		P M K N S H	↓ ↔ f = .0006-.0020 in/rev f = 0.015-0.05 mm/rev ap = .0020-.0030 in* ap = 0.03-0.07 mm* *tool group dependent	 Fine Finishing
 Sintered, all-purpose		P M K N S H	↓ ap = .001-.004 in* ap = 0.03 - 0.1mm* *see Technical Information - Threading on page 450 for expanded recommendations	 Threading

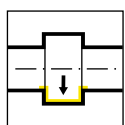

f = .0004-.002 in/rev
f = 0.01-0.05 mm/rev

Grooving

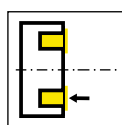

f = .0008-.003 in/rev
f = 0.02-0.08 mm/rev

Face Grooving

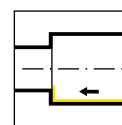

f = .0012-.004 in/rev
f = 0.03-0.1 mm/rev
ap = .004-.020 in
ap = 0.1-0.5 mm

Internal Boring

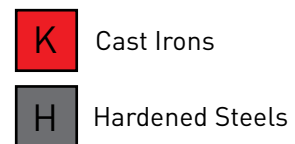
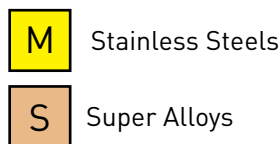
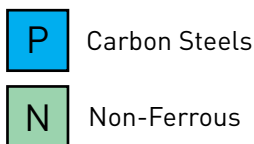
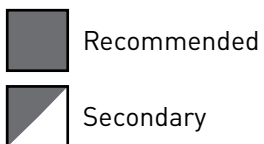

Boring Steel		Depth of Cut, ap (in) Depth of Cut, ap (mm)					
		.020 in 0.5 mm	.040 in 1 mm	.060 in 1.5 mm	.080 in 2 mm	.100 in 2.5 mm	.120 in 3 mm
		Feed Rate, f [in/rev] Feed Rate f [mm/rev]					
R/L105.B0.30.20.045.1	1.5*D	.001-.002 0.03-0.05	.001-.0012 0.02-0.03				
R/L105.B0.30.20.075.1	2.5*D	.001-.002 0.03-0.05	.001-.0012 0.02-0.03				
R/L105.B0.40.20.060.1	1.5*D	.0015-.0025 0.04-0.06	.0015-.0025 0.04-0.06	.0015-.0025 0.04-0.06			
R/L105.B0.40.20.100.1	2.5*D	.0015-.0025 0.04-0.06	.0015-.0025 0.04-0.06	.0015-.0025 0.04-0.06			
R/L105.B0.50.20.075.1	1.5*D	.002-.003 0.05-0.08	.001-.003 0.05-0.08	.0015-.003 0.04-0.07	.0015-.003 0.04-0.07		
R/L105.B0.50.20.125.1	2.5*D	.002-.003 0.05-0.08	.002-.003 0.05-0.08	.0015-.003 0.04-0.07	.0015-.003 0.04-0.07		
R/L105.B0.60.20.090.1	1.5*D	.003-.004 0.07-0.1	.003-.004 0.07-0.1	.003-.004 0.07-0.1	.003-.004 0.07-0.1	.002-.003 0.05-0.08	
R/L105.B0.60.20.150.1	2.5*D	.003-.004 0.07-0.1	.003-.004 0.07-0.1	.003-.004 0.07-0.1	.003-.004 0.07-0.1	.002-.003 0.05-0.08	
R/L105.B0.70.20.105.1	1.5*D	.003-.004 0.07-0.1	.003-.004 0.07-0.1	.003-.004 0.07-0.1	.003-.004 0.07-0.1	.003-.0032 0.07-0.8	.002-.003 0.05-0.07
R/L105.B0.70.20.175.1	2.5*D	.003-.004 0.08-0.1	.003-.004 0.07-0.1	.003-.004 0.07-0.1	.003-.004 0.07-0.1	.003-.0032 0.07-0.08	.002-.003 0.05-0.07

For stainless materials: start with minimum values

Drilling Steel		Feed rate f [in/rev]	Feed rate f [mm/rev]
R/L105.B0.30.20.045.2	1.5*D	.0004-.0008	0.01-0.02
R/L105.B0.30.20.075.2	2.5*D	.0004-.0008	0.01-0.02
R/L105.B0.40.20.060.2	1.5*D	.0004-.0008	0.01-0.02
R/L105.B0.40.20.100.2	2.5*D	.0004-.0008	0.01-0.02
R/L105.B0.50.20.075.2	1.5*D	.0008-.0016	0.02-0.04
R/L105.B0.50.20.125.2	2.5*D	.0008-.0016	0.02-0.04
R/L105.B0.60.20.090.2	1.5*D	.0012-.0020	0.03-0.05
R/L105.B0.60.20.150.2	2.5*D	.0012-.0020	0.03-0.05
R/L105.B0.70.20.105.2	1.5*D	.0012-.0020	0.03-0.05
R/L105.B0.70.20.175.2	2.5*D	.0012-.0020	0.03-0.05

For drilling: the universal geometry (product number ending in .2) is recommended

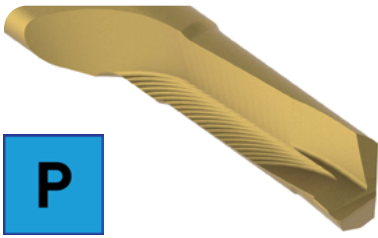

R/L105.B0...1

.1 Chipbreaker Geometry (general steels)

- Turning and boring with large infeeds
- With trailing cutting edge for higher feed rates
- Optimized chip control
- Best for general steels
- For difficult applications and long-chipping materials

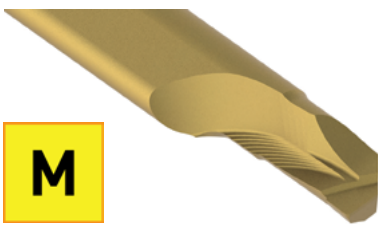

R/L105.B0...2

.2 Universal Geometry (stainless steels)

- Turning and boring with large infeeds
- With trailing cutting edge for higher feed rates
- Reduced cutting pressure, excellent for thin walls
- Optimized for stainless
- Recommended for drilling in steel, stainless and non-ferrous metals

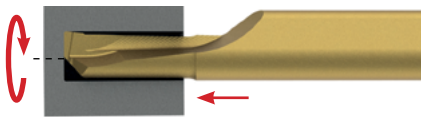

Drilling into the solid and achieving a flat hole bottom

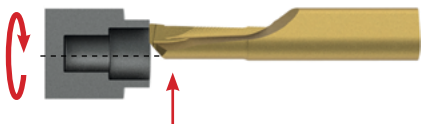

Turning of face profiles

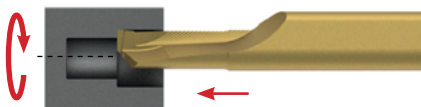

Turning of internal profiles

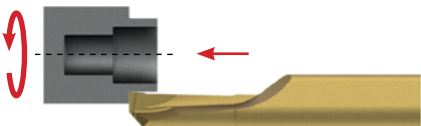

Turning of external profiles
Note: spindle direction must be reversed

Threading

All threads with a helix angle up to 4.5° can be produced using Horn standard threading inserts. No special shims or approach angles are required.

Insert Seats

The insert seats of the Mini and Supermini® tools guarantee precise positioning at the cutting-edge height. Attention should always be given to the cutting-edge height, as deviations can cause problems, especially when machining very small diameters.

Chip Evacuation

Use narrow cutting widths so the chip remains smooth and can flow past the tool and out of the bore. To avoid chip jams, plunge with intermittent pauses.

Coolant

Use filtered coolant to flush out chips and cool the cutting edge. A minimum coolant pressure of approximately 145 PSI/10 bar is recommended.

	Steel (N/mm ² Tensile strength)					Stainless steel	Grey cast iron	Alu
	400-500	500-700	700-850	850-1150	> 1150	303	Class 30	6061
V_{max} SFM	525	460	395	295	230	295	330	985
V_{max} m/min	160	140	120	90	70	90	100	300

Pitch		Number of passes							
mm	Gg/'" tpi	Steel (N/mm ² Tensile strength)					Stainless steel	Grey cast iron	Alu
		400-500	500-700	700-850	850-1150	> 1150	303	Class 30	6061
0.8	32	10	10	12	12	14	14	12	10
1.0	24	13	13	15	15	18	18	15	13
1.25	20-19	16	16	19	19	22	22	19	16
1.5	16	20	20	23	23	27	27	23	20
1.75	14	23	23	27	27	31	31	27	23
2.0	12-11	27	27	30	30	36	36	30	27
2.5	10	33	33	38	38	45	45	38	33
3.0-3.5	8	40	40	46	46	54	54	46	40

Table values are approximate, exact values will be process-dependent.

Important:

- The first pass should start with a smaller infeed to avoid chipping the cutting edge
- Finishing passes (with no depth of cut) are not shown in this table

Internal Threading Feed Direction

Right hand thread

Left hand thread

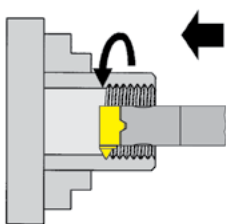

Insert right hand

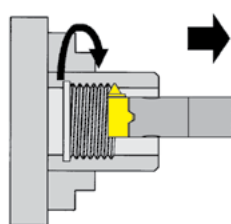

Insert left hand

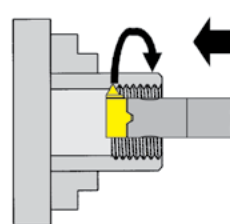

Insert left hand

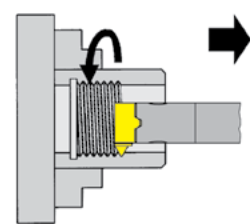

Insert right hand

Threading In-Feed Techniques:

Radial In-Feed

Material removed on both sides of the insert simultaneously.
The most common method for thread production.



Modified Flank In-Feed

Less wear of the trailing edge and better surface finish on the corresponding thread surface.



Alternating Flank In-Feed

Both edges are used evenly, resulting in longer tool life.



Flank In-Feed

Lower cutting pressure and better head dissipation.



Insert Type 105

A rotating full-radius insert can be used to debur internal holes

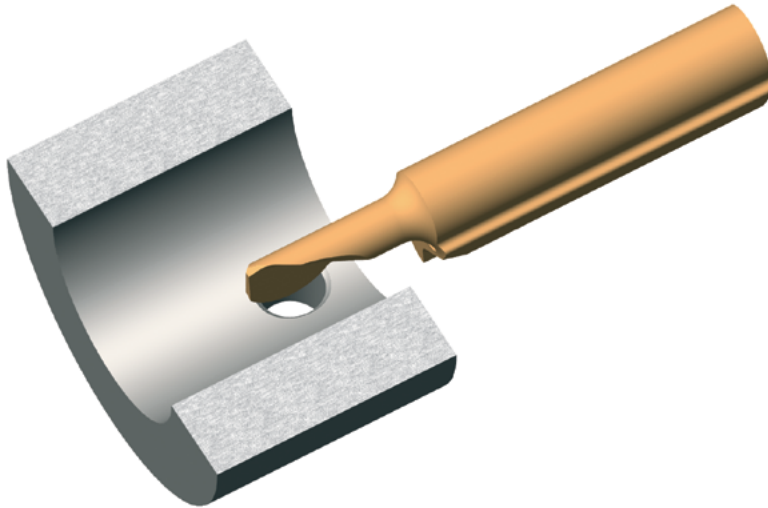

Insert Type 105

A full-radius face groove insert can be used to create an external profile.

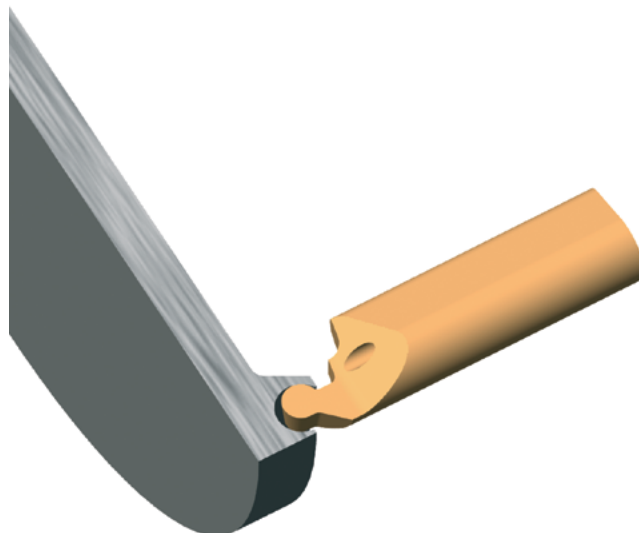

Insert Type 105

A boring bar insert can be used to machine an undercut inside a hole

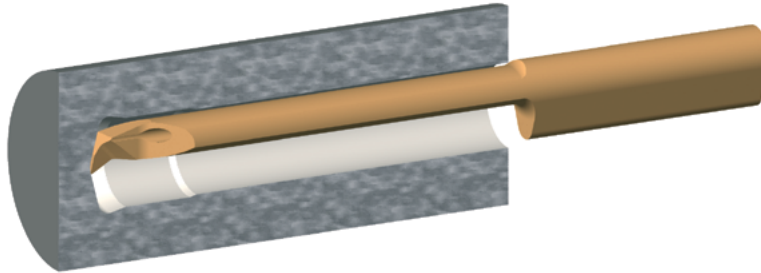

Insert Type 105

A face groove insert can be used to machine a dovetail face groove

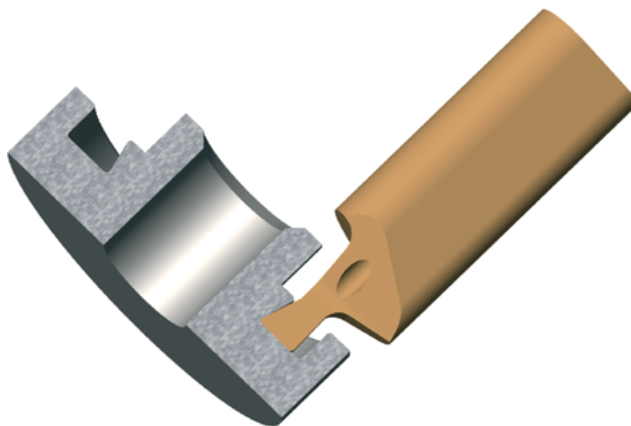

Insert Type 108

A special angled grooving insert can be used to machine an under-cut relief

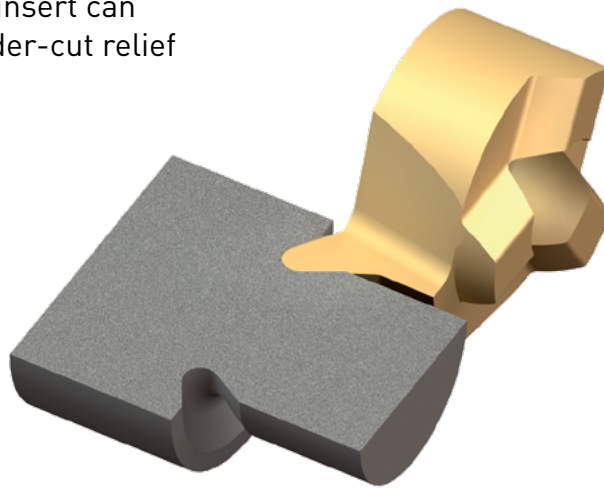

Insert Type 111

A special ID form insert can be used to groove and face a feature

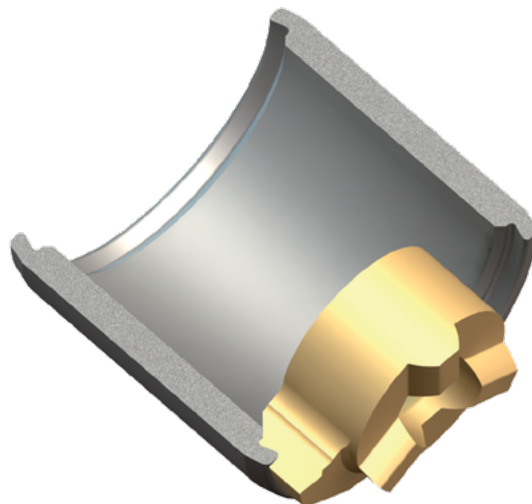

Insert type 111
Special ID form groove and facing



Hexagon Broaching

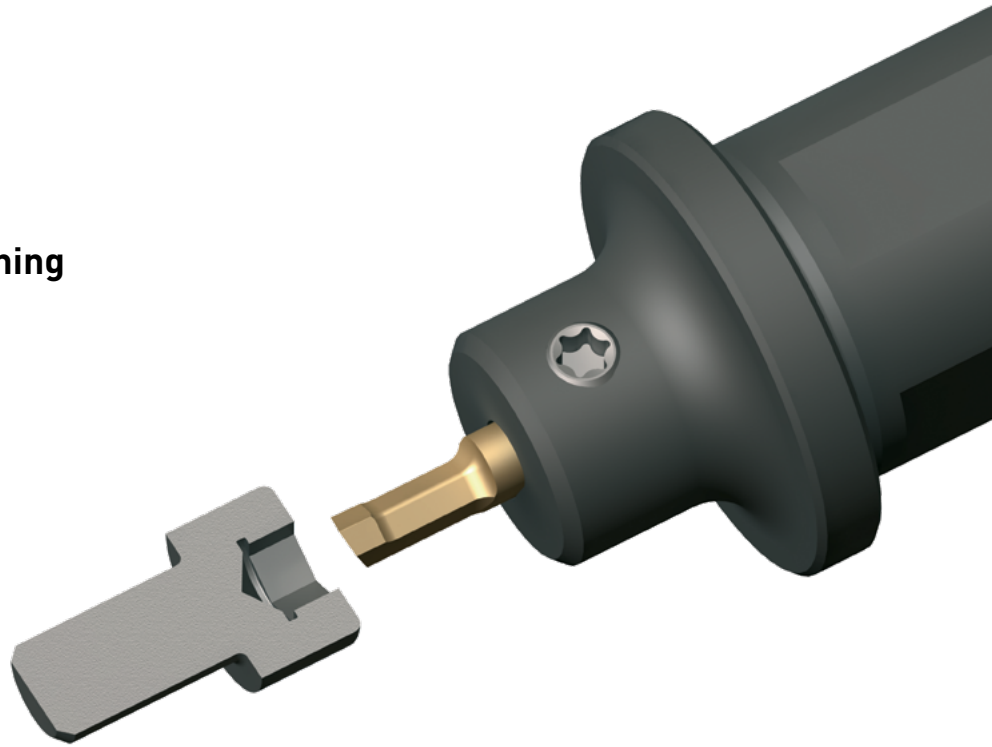

Torx Broaching

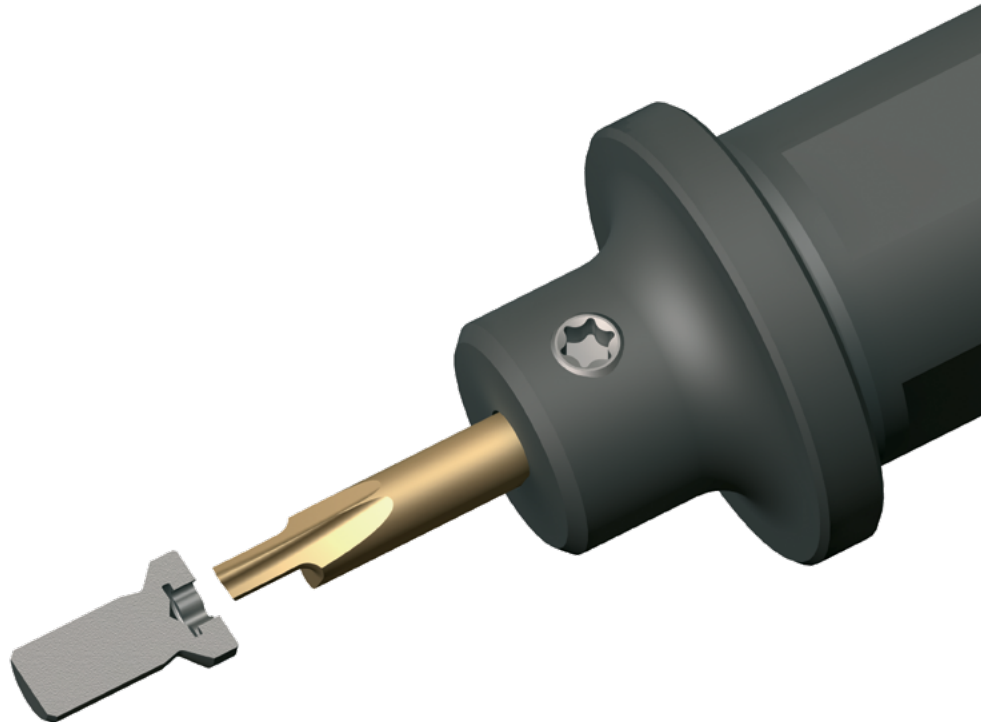

For more information, please refer to the Turning and Broaching catalog.

Torque values are now laser-etched on the holder body for quick reference.

Previous versions did not include torque markings.

The use of additional lubricants, such as copper paste or similar products, are not recommended.

System	Screw	M_d Nm	Wrench	Driver Size
001	8.075.1835	5	SW4DIN911	DSW40K
AIH	030.3509.T15P	2.5	T10PL	DT10PK
	6.075T15P	5	T15PQ	DT15PK
B10P	2.6.5T8EP	1.2	T8PL	DT8PK
B11P	3.10T9P	1.8	T9PL	DT9PK
B18P	5.13T20EP	6	T20PQ	DT20PK / DT20PQ
B105	6.075T15P	5	T15PQ	DT15PK
B105.00...A...	030.00M8.1188	4	T25PQ	DT25PK / DT25PQ
B105.00...S...	030.0000.1157	2	T15PL	DT15PK
B106	1.8.4T6EP	0.9	T6PL	DT6PK
B107	2.2.5T7EP	1.1	T7PL	DT7PK
B108	2.6.5T8EP	1.2	T8PL	DT8PK
B109	6.075T15P	5	T15PQ	DT15PK
B110	6.075T15P	5	T15PQ	DT15PK
B111	3.512T10EP	3	T10PL	DT10PK
B114	4.12T15EP	5	T15PQ	DT15PK
B116	5.13T20EP	6.5	T20PQ	DT20PK / DT20PQ
BA114	4.12.T15P	5	T15PQ	DT15PK
BKT	6.075T15P	5	T15PQ	DT15PK
BKT105...S...	030.0000.1157	2	T15PL	DT15PK
BU105	6.075T15P	5	T15PQ	DT15PK
BU105.00...S...	030.0000.1157	2	T15PL	DT15PK
H105	6.075T15P	5	T15PQ	DT15PK
HC105	6.075T15P	5	T15PQ	DT15PK
HC114	4.12T15EP	5	T15PQ	DT15PK
HSKT	6.075T15P	5	T15PQ	DT15PK
IR105	6.075T15P	5	T15PQ	DT15PK
KC760	5.12.T20P	6	T15PQ	DT15PK
N	6.075T15P	5	T15PQ	DT15PK
VDI	6.075T15P	5	T15PQ	DT15PK
WFB...105	6.075T15P	5	T15PQ	DT15PK
WFB...110	6.075T15P	5	T15PQ	DT15PK
WFB...114	4.12T15EP	5	T15PQ	DT15PK



D 041 VL
0.4-1 Nm



D 15 VL
1-5 Nm



D 28 VL
2-7 Nm



ED 28 VL
for
D041VL / D15VL / D28VL

Variable Torque Drivers

Torque setting is adjusted with the included wrench.
Torque value is shown in display window.

Standard: EN ISO 6798, BS EN 26789,
ASME B107.14.M.

Accuracy: $\pm 6\%$

Adjustment Wrench

Adjusts the torque setting on the drivers shown above.



D515QL
5-14 Nm

Variable Torque Driver

Torque setting is adjusted with the included wrench.

Torque value is shown in display window.

Standard: EN ISO 6798, BS EN 26789, ASME B107.14.M.

Accuracy: $\pm 6\%$,



ED515QL
for
D515QL

Adjustment Wrench

Adjusts the torque setting on the driver shown above.



Driver for Torx-Plus® Screws

DT6PK
DT7PK
DT8PK
DT9PK
DT10PK
DT15PK
DT20PK
DT25PK

for
D041VL / D15VL / D28VL



Plus

Controlled torque setting when used with a Wiha torque driver.



Driver for Torx Screws

DT6K
DT8K
DT15K

for
D041VL / D15VL / D28VL



Controlled torque setting when used with a Wiha torque driver.



Driver for Torx-Plus® Screws

DT15PQ
DT20PQ
DT25PQ
DT27PQ
DT30PQ

for
D515QL



Plus

Controlled torque setting when used with a Wiha torque driver.



Driver for Hex Screws

DSW15K
DSW20K
DSW25K
DSW30K
DSW40K

for
D041VL / D15VL / D28VL



Controlled torque setting when used with a Wiha torque driver.

DSW50K
DSW60K

for
D15QL



Universal Bitholder for C6.3 und E6.3 (1/4'') Bits

D14ZBK

for
D041VL / D15VL / D28VL

Controlled torque setting when used with a Wiha torque driver.



Universal Bitholder for C6.3 und E6.3 (1/4'') Bits

D14ZBQ

for
D515QL

Controlled torque setting when used with a Wiha torque driver.



14ZQK

Universal Bitholder for C6.3 und E6.3 (1/4'') Bits

Hex bit handle.



- T6PW
- T7PW
- T8PW
- T9PW
- T10PW
- T15PW
- T20PW
- T25PW
- T30PW



Plus

Hex Key for Torx Plus® Screws

For all Torx Plus® screws.

Note: Torx Plus® does NOT fit regular Torx.



FIND YOUR TOOLING SOLUTION

horn-eshop.us
horn-group.com/us

FRANKLIN, TENNESSEE

USA

—

Horn USA Inc.
1870 General George Patton Dr,
37067 Franklin, TN

Tel +1 (615) 771-4100

Fax +1 (615) 771-4101

info@us.horn-group.com

horn-group.com/us