

GROOVING

2021/2022



HORN TOOLS

New catalogues from HORN - benchmarks for productivity

From single part to series production, for standard or special applications: our tools offer you fast, economical and high quality solutions.

The current HORN catalogues are divided into the following sections:

- Grooving
- Supermini & Mini Internal Machining
- Modular Holder Systems
- Ultra Hard Cutting Materials
- Milling Systems
- Drilling / Reaming
- Solid Carbide Mills
- Milling Catalogue Boehlerit
- Turning Catalogue Boehlerit

To assist you when choosing cutting parameters, our tables provide proven empirical values. Take advantage of the expertise of our office staff and sales engineers, because we know the market well and have the right solutions for your applications and challenges.



Lothar Horn
CEO
Paul Horn GmbH



Markus Horn
CEO
Paul Horn GmbH



Matthias Rommel
CEO
Paul Horn GmbH

Index

A System 100 / 101

B System 117

C System 119 / 123 / 223

D System 209

E System 216

F System 217

G System 224

H System 229 / 259

I System 231

J System 262

K System 264

L System 274

M System 32T

A

B

C

D

E

F

G

H

I

J

K

L

M



Index

- N** System 34T
- O** System 312
- P** System 315
- Q** System 316
- R** System 64T
- S** Tools for Swiss Type Machines
- T** Face Grooving
- U** Parting Off
- V** Technical Instructions
- W** Speed-Forming
- X** Broaching
- Y** Additional Equipment

N

O

P

Q

R

S

T

U

V

W

X

Y

System	15 25A	100	101	117	119	123	209	216	217	223	224
Internal Grooving											
Bore Ø	.590 - 1.969				≥ .630	≥ .630	≥ .630	≥ .787	≥ .787	≥ .709	≥ 1.102
Width of Groove	.079 - .157				.079 - .118	.079 - .118	.079 - .118	.079 - .236	.02 - .209	.047 - .118	.079 - .236
Grooving					•	•	•	•	•	•	•
Turning					•		•	•		•	•
Threading											•
Profiling							•	•		•	•
Face Grooving	•										
External Grooving											
Depth of Groove	≤ .984	≤ 2.165	≤ .512	≤ .394		≤ .984			≤ .185	≤ .433	≤ 1.280
Width of Groove	.079 - .157	.079 - .630	.047 - .063	.394 - 1.772		.079 - .118			.02 - .209	.047 - .118	.079 - .236
Grooving		•	•			•			•	•	•
Turning		•								•	•
Part Off		•	•							•	•
Threading											•
Profiling				•					•		•
Face Grooving	•										•
Chapter	S	A	A	B	C	C	D	E	F	C	G

Special tools upon request

Dimensions in inch

System	229 259	231	262	264	274	32T	34T	312	315	316	64T
Internal Grooving											
Bore Ø	≥ 1.496	≥ 2.953						≥ 1.811	≥ 1.693		
Width of Groove	.098 - .394	.098 - .394						.02 - .248	.02 - .315		
Grooving	•	•						•	•		
Turning	•								•		
Threading	•	•							•		
Profiling	•								•		
Face Grooving											
External Grooving											
Depth of Groove	≤ .984	≤ .433	≤ .295	≤ .630	≤ .236	≤ .138	≤ .256	≤ .315	≤ .236	≤ .315	≤ .217
Width of Groove	.098 - .394	.098 - .394	.001 - .236	.059 - .118	.02 - .276	.02 - .098	.041 - .197	.02 - 0.248	0.02 - .315	.059 - 0.118	.02 - .124
Grooving	•	•	•	•	•	•	•	•	•	•	•
Turning	•		•	•	•	•	•	•	•	•	•
Part Off	•		•	•	•	•	•	•	•	•	•
Threading	•	•		•	•	•			•		•
Profiling	•								•		
Face Grooving	•	•						•	•		
Chapter	H	I	J	K	L	M	N	O	P	Q	R

Special tools upon request

Dimensions in inch

System	15 25A	100	101	117	119	123	209	216	217	223	224
Internal Grooving											
Bore Ø	15 - 50				≥ 16	≥ 16	≥ 16	≥ 20	≥ 20	≥ 18	≥ 28
Width of Groove	2 - 4				2 - 3	2 - 3	2 - 3	2 - 6	0.5 - 5.3	1.2 - 3	2 - 6
Grooving					•	•	•	•	•	•	•
Turning					•		•	•		•	•
Threading											•
Profiling							•	•		•	•
Face Grooving	•										
External Grooving											
Depth of Groove	≤ 25	≤ 55	≤ 13	≤ 10		≤ 25			≤ 4.7	≤ 11	≤ 32.5
Width of Groove	2 - 4	2 - 16	1.2 - 1.6	10 - 45		2 - 3			0.5 - 5.3	1.2 - 3	2 - 6
Grooving		•	•			•			•	•	•
Turning		•								•	•
Part Off		•	•							•	•
Threading											•
Profiling				•					•		•
Face Grooving	•										•
Chapter	S	A	A	B	C	C	D	E	F	C	G

Special tools upon request

Dimensions in mm

System	229 259	231	262	264	274	32T	34T	312	315	316	64T
Internal Grooving											
Bore Ø	≥ 38	≥ 75						≥ 46	≥ 43		
Width of Groove	2.5 - 10	2.5 - 10						0.5 - 6.3	0.5 - 8		
Grooving	•	•						•	•		
Turning	•								•		
Threading	•	•							•		
Profiling	•								•		
Face Grooving											
External Grooving											
Depth of Groove	≤ 25	≤ 11	≤ 7,5	≤ 16	≤ 6	≤ 3,5	≤ 6,5	≤ 8	≤ 6	≤ 8	≤ 5,5
Width of Groove	2.5 - 10	2.5 - 10	.025 - 6	1.5 - 3	0.5 - 7	0.5 - 2.5	1.03 - 5	0.5 - 6.3	0.5 - 8	1.5 - 3	0.5 - 3.15
Grooving	•	•	•	•	•	•	•	•	•	•	•
Turning	•		•	•	•	•	•	•	•	•	•
Part Off	•		•	•	•	•	•	•	•	•	•
Threading	•	•		•	•	•			•		•
Profiling	•								•		
Face Grooving	•	•						•	•		
Chapter	H	I	J	K	L	M	N	O	P	Q	R

Special tools upon request

Dimensions in mm

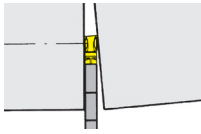

System 100
 $t_{max} = \leq 2.165''$ (55 mm)

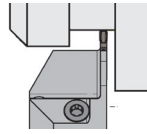

System 101
 $t_{max} = \leq .512''$ (13 mm)

Toolholder
 H100/HU100

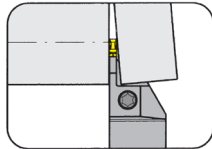

Page
 A3-A16, A19, A21

Toolholder
 H101

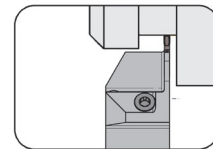

Page
 A41

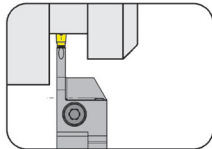

Page
 A17-A18, A20, A22, A23-A27

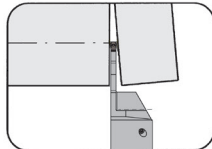

Page
 A35-A38

Insert
 S100/S101

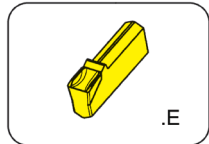

Page
 A28

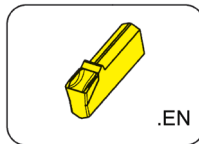

Page
 A29, A41

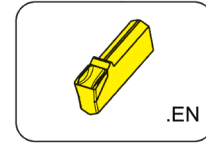

Page
 A30

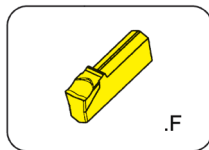

Page
 A32

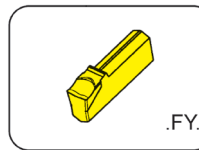

Page
 A33

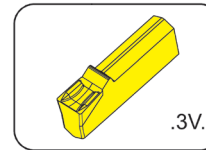

Page
 A34, A42

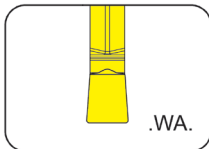

Page
 A35

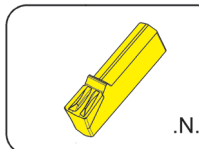

Page
 A36

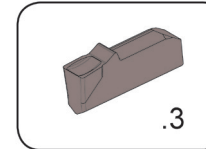

Page
 A44

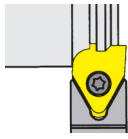

$t_{max} = \leq .394" (10 \text{ mm})$
 $w = .394 - 1.772" (10 - 45 \text{ mm})$

Toolholder
H117/HU117

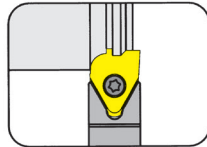

Page
B3-B6, B8

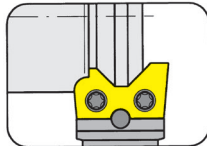

Page
B10-B11

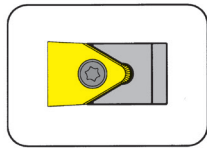

Page
B13

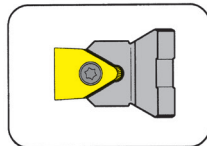

Page
B14

Insert
S117

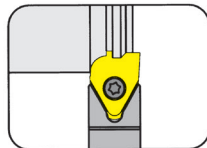

Page
B7, B9

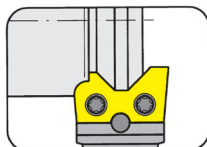

Page
B12

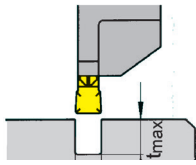

$w = .043 - .118'' (1.1 - 3 \text{ mm})$
 $t_{\text{max}} = .394'' (10 \text{ mm})$

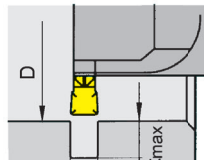

$w = .043 - .118'' (1.1 - 3 \text{ mm})$
 $t_{\text{max}} = .248'' (6.3 \text{ mm})$
 $D \geq .630'' (16 \text{ mm})$

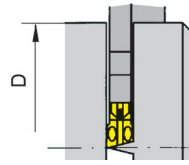

$w = .078 - .118'' (2 - 3 \text{ mm})$
 $D_{\text{max}} \leq 1.969'' (50 \text{ mm})$

Toolholder
HU223/H223

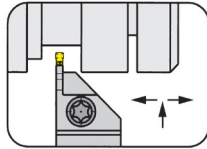

Page
C3-C4, C27

Insert
S119/S123

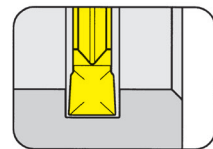

Page
C18

Cartridge
E223

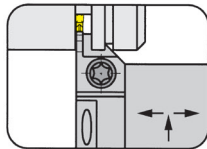

Page
C5

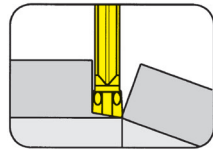

Page
C19-C20

Toolholder
BU119/B119

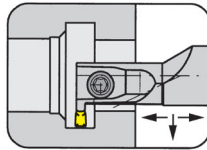

Page
C6-C7

Indexable Insert
S223

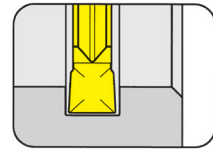

Page
C21, C23-C24

Toolholder
BU223/B223

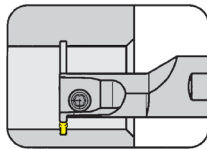

Page
C8-C12

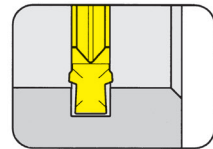

Page
C22

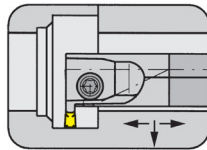

Page
C13-C14

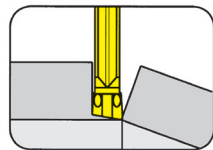

Page
C25-C26

Basic Toolholder
B223

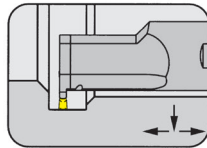

Page
C15-C16

Cassette
BK223

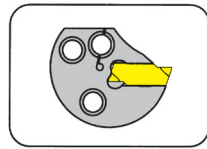

Page
C17

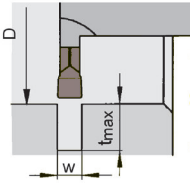
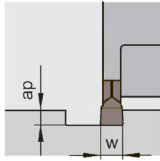

$w = .078 - .118" (2 - 3 \text{ mm})$ $w = .078 - .118" (2 - 3 \text{ mm})$
 $a_{p \text{ max}} = .039" (1 \text{ mm})$ $t_{\text{max}} = .197" (5 \text{ mm})$
 $D \geq .630" (16 \text{ mm})$

Toolholder
B209

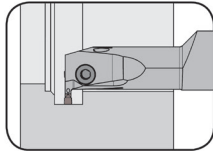

Page
D3

Indexable Insert
S209

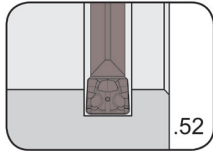

Page
D4

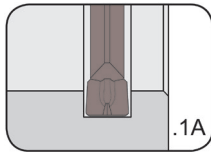

Page
D5

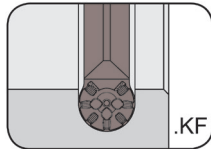

Page
D6

D

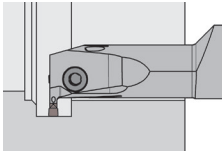

$D_{\min} = .787" (20 \text{ mm})$
 $t_{\max} = .295" (7.5 \text{ mm})$

Toolholder
B216

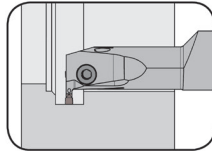

Page
E3

Indexable Insert
S216

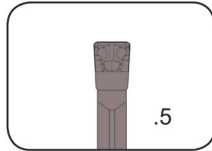

Page
E4

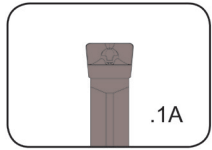

Page
E5

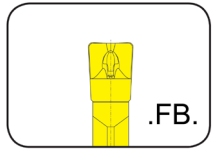

Page
E6

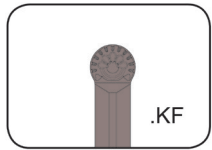

Page
E7

E

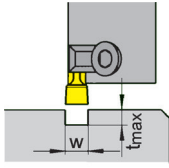

w = .02 - .209 (0.5 - 5.3 mm)
 t_{max} = .157" (4mm)

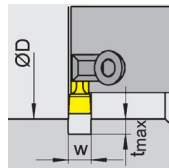

w = .02 - .209" (0.5 - 5.3 mm)
 t_{max} = .185" (4.7 mm)
 D ≥ .787" (20 mm)

Toolholder
 U240/240/U248/248

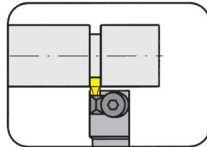

Page
 F3-F8

Indexable Insert
 217

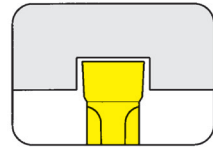

Page
 F19-F20

Toolholder
 U230/230/U250/250

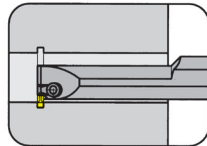

Page
 F9-F10

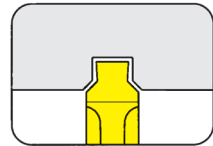

Page
 F21

Toolholder
 U233/233/U253/253

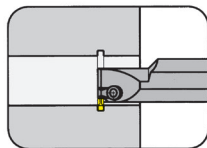

Page
 F11-F12

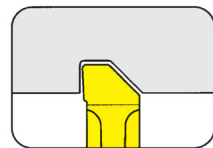

Page
 F22

Toolholder
 234/U254/254

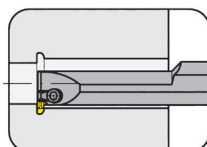

Page
 F13-F14

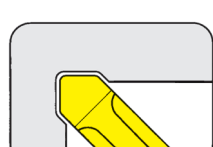

Page
 F23

Toolholder
 U235/235/U255/255

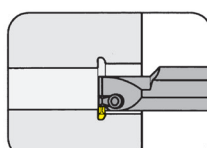

Page
 F15-F16

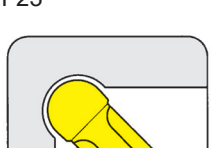

Page
 F24

Toolholder
 U245/245

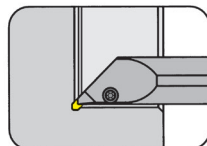

Page
 F17-F18

Cartridge
 232

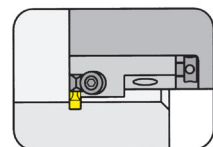

Page
 F25

F

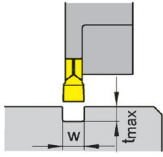

$w = .078 - .236"$
(2 - 6 mm)
 $t_{max} = .709"$
(18 mm)

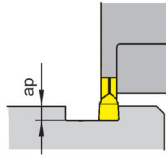

$w = .118 - .236"$
(3 - 6 mm)
 $a_{pmax} = .157"$
(4 mm)

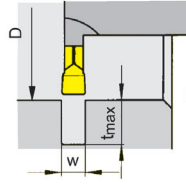

$w = .078 - .236"$
(2 - 6 mm)
 $t_{max} = .512"$ (13 mm)
 $D \geq 1.102"$ (28 mm)

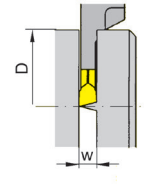

$w = .078 - .236"$
(2 - 6 mm)
 $D = 2.205"$ (56 mm)
 $t_{max} = .709"$ (18 mm)

Toolholder
HU224/H224/BU224/
B224

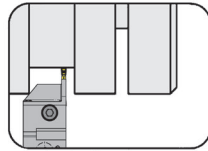

Page
G4

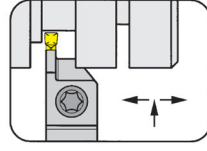

Page
G5-G24

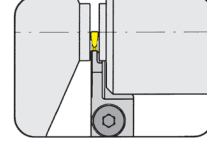

Page
G26

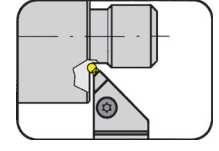

Page
G25

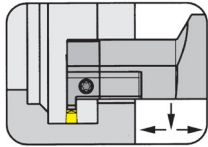

Page
G34-G36

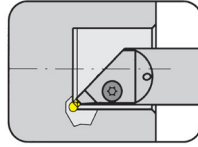

Page
G39-G41

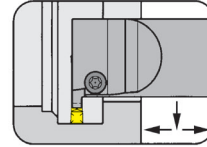

Page
G27-G33

Cassette
BK224/BK224...IK

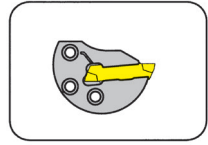

Page
G37-G38

Insert
S224/S124

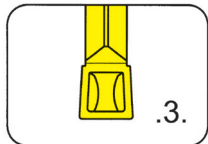

Page
G42

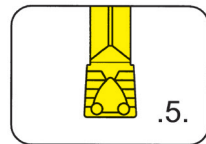

Page
G45

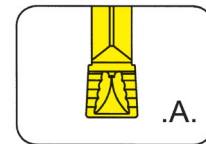

Page
G47

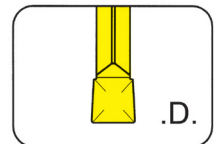

Page
G49

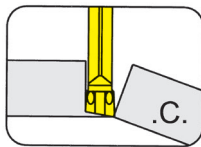

Page
G51

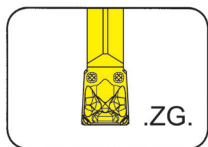

Page
G52

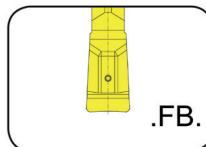

Page
G53

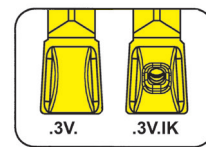

Page
G54, G68

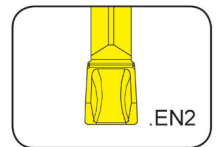

Page
G55

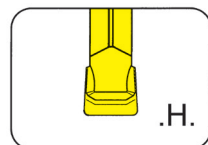

Page
G56

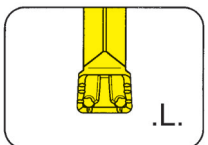

Page
G57-G58

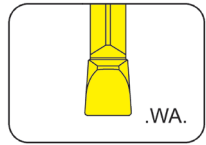

Page
G59

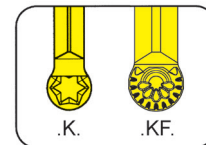

Page
G60-G61

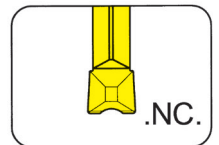

Page
G62

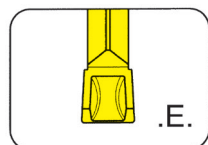

Page
G63

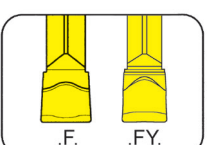

Page
G64-G65

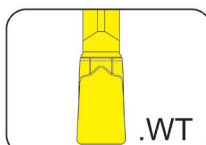

Page
G66

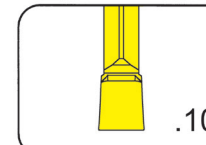

Page
G67

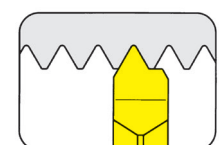

Page
G69-G70

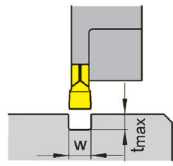

$w = .098 - .394"$
(2.5 - 10 mm)
 $t_{max} = .984"$ (25 mm)

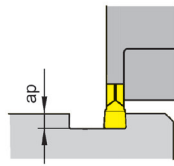

$w = .118 - .236"$
(3 - 6 mm)
 $a_p \leq .157"$ (4 mm)

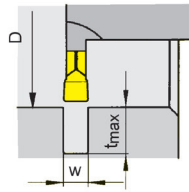

$w = .118 - .394"$
(3 - 10 mm)
 $t_{max} = 0.591"$ (15 mm)
 $D \geq 1.496"$ (38 mm)

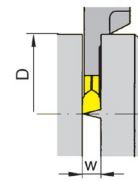

$w = .118 - .157"$
(3 - 4 mm)
 $t_{max} = .984"$ (25 mm)

Grooving External

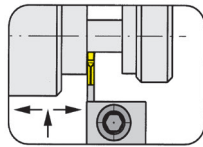

Page H4-H13

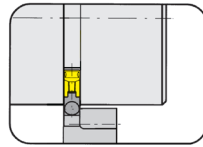

Page H14-H25

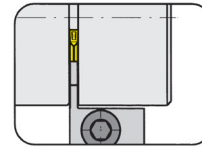

Page H26-H32

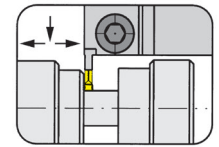

Page H33-H36

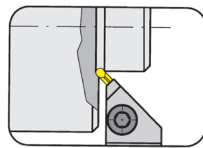

Page H37-H38

Grooving Internal

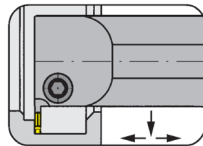

Page H39-H50

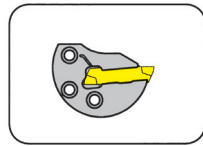

Page H51-H55

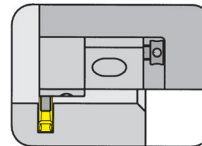

Page H56

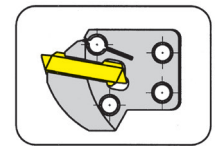

Page H57

Indexable Insert S229

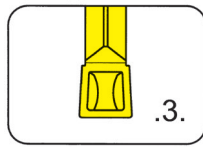

Page H59

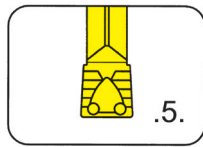

Page H61

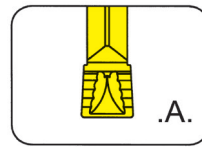

Page H63

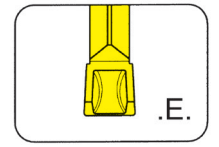

Page H64

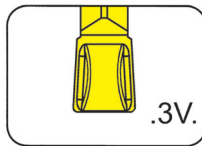

Page H67

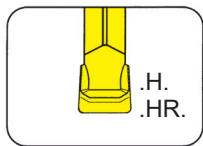

Page H68-H69

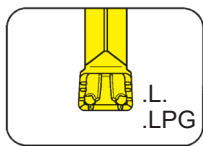

Page H70-H71

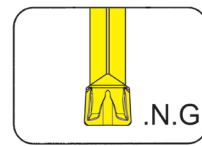

Page H72

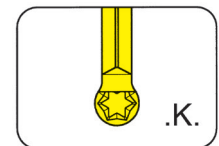

Page H74-H75

Indexable Insert 229

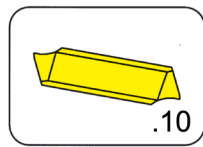

Page H77

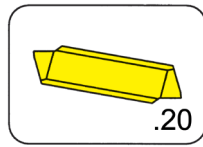

Page H79

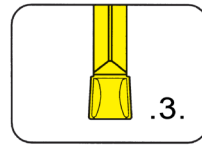

Page H81

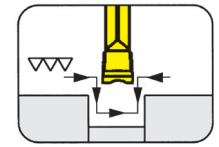

Page H82

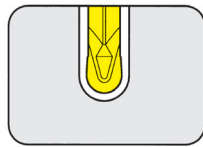

Page H84

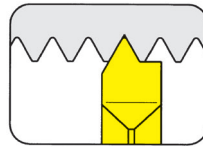

Page H85-H87

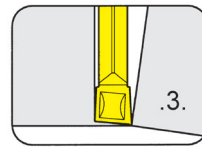

Page H88

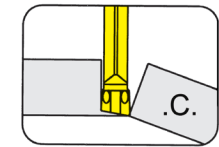

Page H89-H90

Toolholder H259

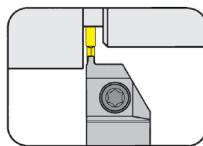

Page H91

Indexable Insert 259

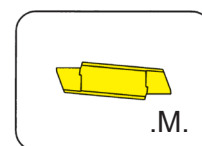

Page H92

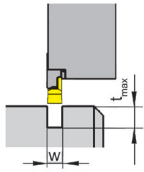

$w = .098 - .394"$
 (2.5 - 10 mm)
 $t_{max} = .433$ (11 mm)

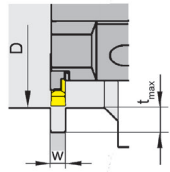

$w = .157 - .394"$ (4-10 mm)
 $t_{max} = .197 - .354"$ (5 - 9 mm)
 $D = 2.953 - 7.874"$
 (75 - 200 mm)

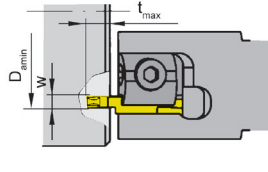

$w = .118 - .394"$
 (3 - 10 mm)
 $t_{max} = .315"$ (8 mm)
 $D_{a\ min} \geq 1.181"$ (30 mm)

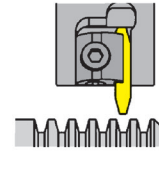

Metric trapezoidal thread

Toolholder
211/221/228

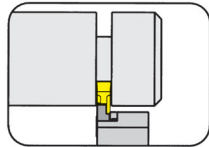

Page
13-14

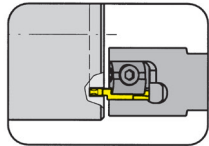

Page
111-112

Cartridge
208

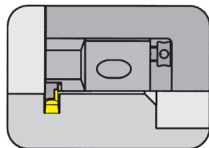

Page
15-16

Indexable Insert
231

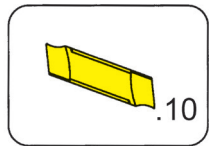

Page
17-18

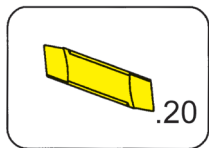

Page
19-110

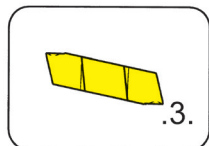

Page
113

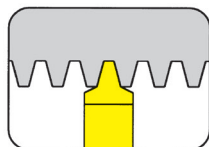

Page
114

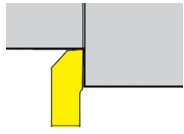

Grooving and Side Turning

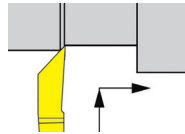

Copy Turning (Finishing)

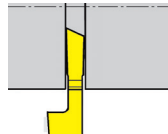

Parting off

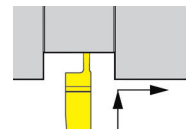

Grooving and Back Turning

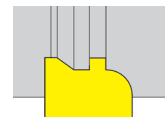

Semi-finished Insert

Toolholder
262

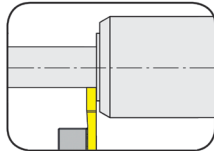

Page
J3

Indexable Insert
S262

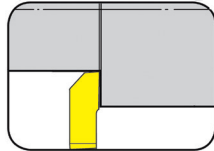

Page
J4

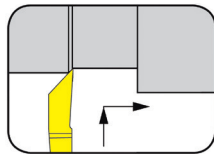

Page
J5

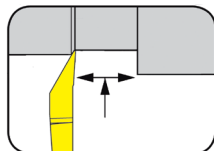

Page
J6

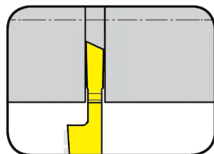

Page
J7

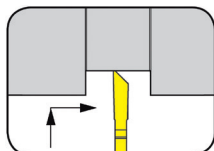

Page
J8-J9

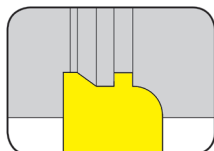

Page
J10



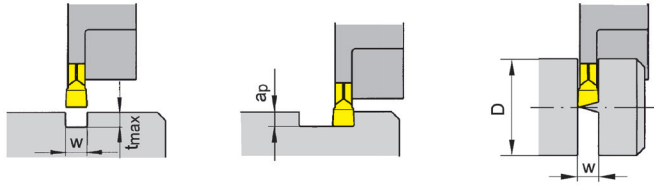

$w = .059 - .118''$ (1.5 - 3 mm)
 $t_{max} = .630''$ (16 mm)

$w = .059''$ (1.5 mm)
 $a_p = .089''$ (2.25 mm)

$w = .059 - .118''$ (1.5 - 3 mm)
 $D = .787 - 1.260''$ (20 - 32 mm)

Toolholder
HU264/H264

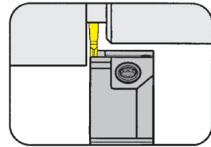

Page
K3-K7

Indexable Insert
264

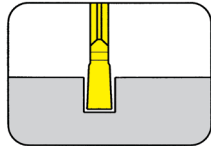

Page
K8, K10, K12

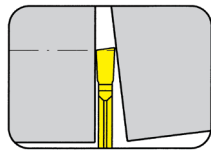

Page
K9, K11

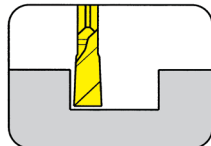

Page
K13-K14

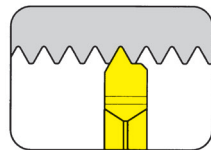

Page
K15

K

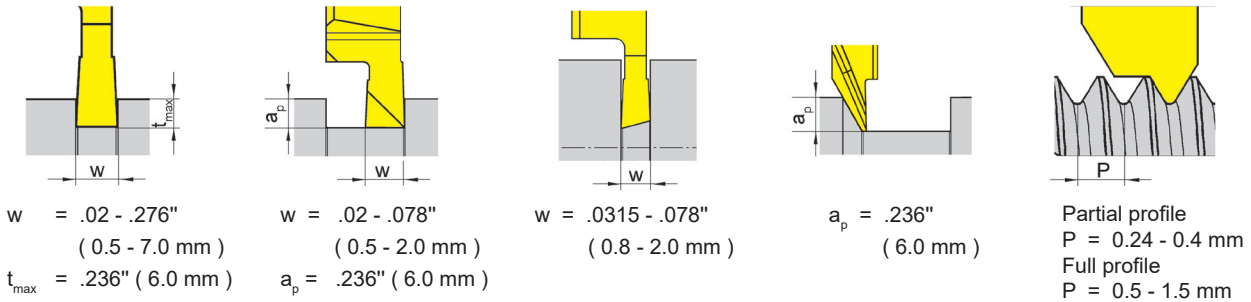

Toolholder
 HU274/H274/
 H274...E

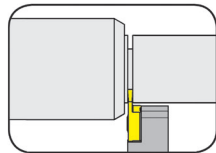

Indexable Insert
 S274/S274...E/
 S274...SF

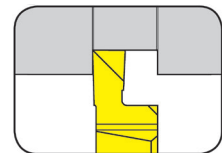

Page
 L3-L4, L7-L8, L33

Page
 L15-L16, L35-L36

Toolholder
 HU274/H274

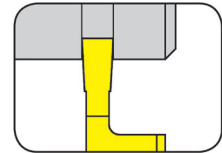
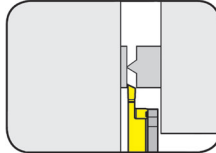

Page
 L5,L6

Page
 L17-L19, L37-L39

Toolholder
 HC274

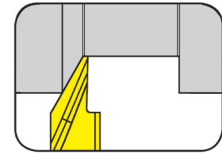
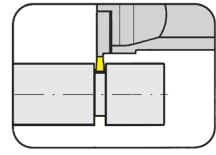

Page
 L10

Page
 L20, L40

Toolholder
 H274

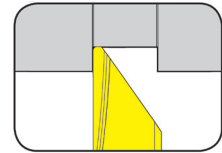
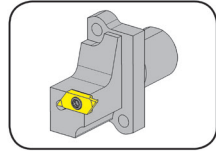

Page
 L11

Page
 L21-L22, L41

Toolholder Graf
 974

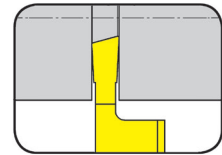
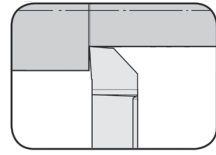
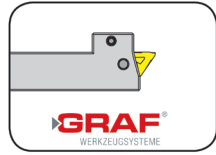

Page
 L9

Page
 L54

Page
 L23-L28, L42-L47

Cartridge
 KT274/KTC274

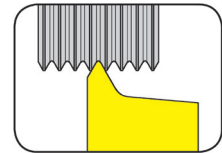
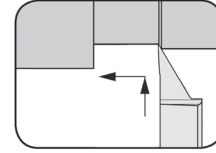
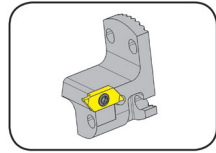

Page
 L12-L13

Page
 L55-L56

Page
 L29-L30, L48-L49

Graf Cartridge
 99

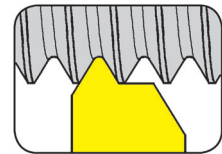
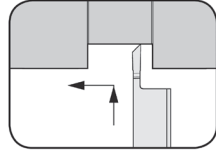
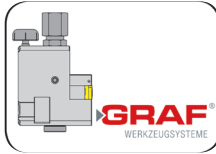

Page
 L14

Page
 L57-L60

Page
 L31-L32, L50-L51



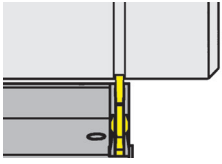

w = .02 - .098
(0.5 - 2.5 mm)
t_{max} = .138 (3.50 mm)

Toolholder
H32T

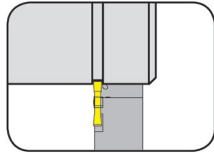

Page
M3-M4

Indexable Insert
S32T

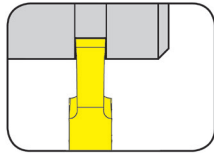

Page
M5-M6

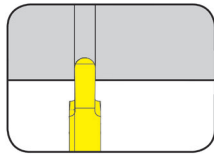

Page
M7

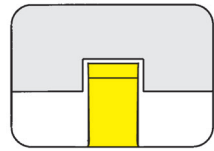

Page
M8

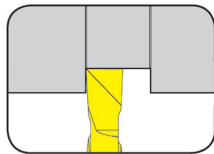

Page
M9

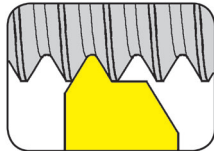

Page
M10

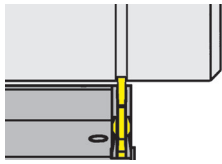

w = .041 - .197"
(1.03 - 5.0 mm)
t_{max} = .256 (6.50 mm)

Toolholder
H34T

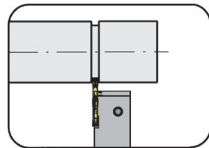

Page
N3-N5

Indexable Insert
S34T

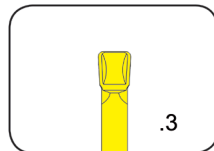

Page
N6

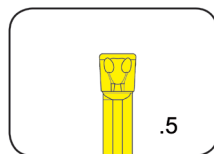

Page
N7

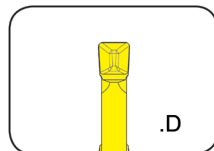

Page
N8

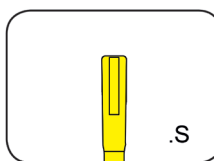

Page
N9

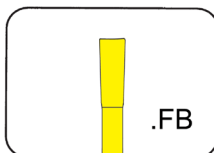

Page
N10

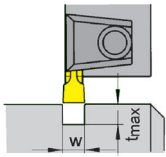

$w = .02 - .248"$
(0.5 - 6.3 mm)
 $t_{max} = .315$ (8.0 mm)

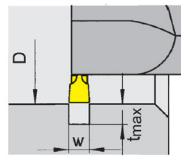

$w = .02 - .248"$
(0.5 - 6.3 mm)
 $t_{max} = .217"$ (5.5 mm)
 $D \geq 1.811"$ (46 mm)

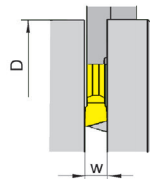

$w = .02 - .248"$
0.5 - 6.3 mm
 $D = .472"$ (12 mm)
 $t_{max} = .315"$ (8 mm)

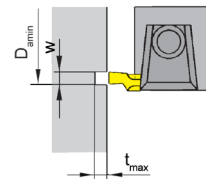

$w = .059 - .118"$
(1.5 - 3 mm)
 $t_{max} = .118"$ (3 mm)
 $D_{amin} = .787"$ (20 mm)

Toolholder
360/361/368/369

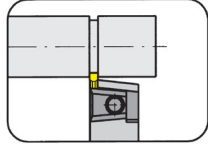

Page
O3-O10, O20-O22

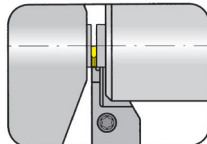

Page
O11-O13

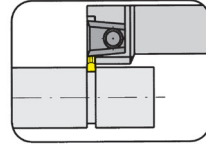

Page
O14-O15

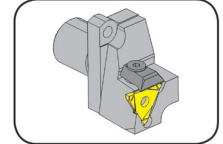

Page
O16

Toolholder
64/65/99
N67/N68/N98/390/391
309/340

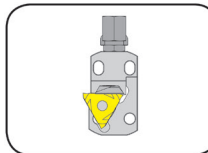

Page
O17-O18

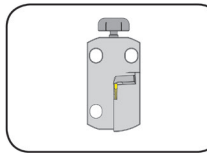

Page
O19

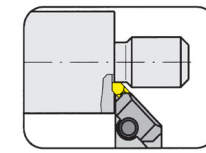

Page
O23-O24

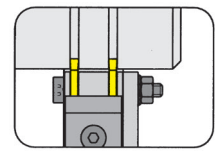

Page
O25-O26

Toolholder
340/330

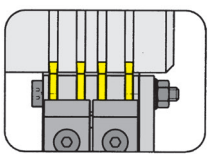

Page
O27-O28

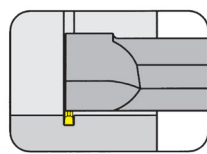

Page
O29-O30

Indexable Insert
S312

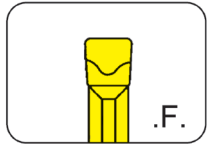

Page
O31

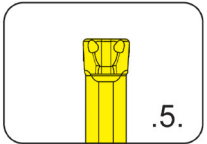

Page
O32-O33

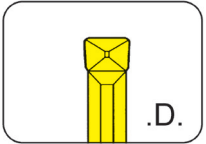

Page
O34-O35

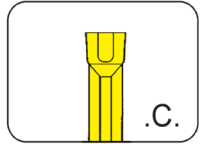

Page
O36

Indexable Insert
312

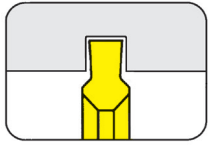

Page
O37

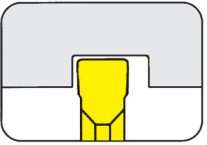

Page
O38-O46

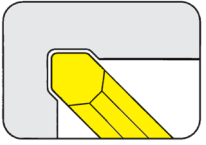

Page
O47-O48

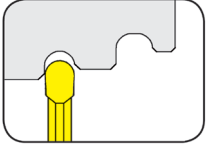

Page
O49-O50

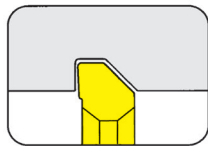

Page
O51-O52

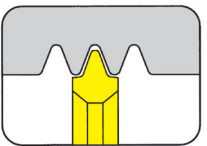

Page
O53

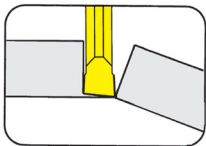

Page
O55-O57

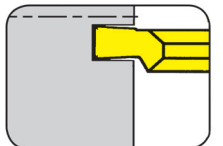

Page
O58-O59

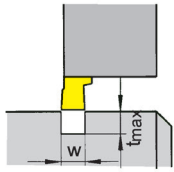

$w = .02 - .295"$
(0.5 - 7.5 mm)
 $t_{max} = .197"$ (5 mm)

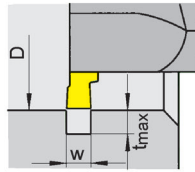

$w = .02 - .138"$
(0.5 - 3.5 mm)
 $t_{max} = .197"$ (5 mm)
 $D \geq 1.693"$ (43 mm)

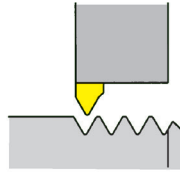

Metric trapezoidal thread
External

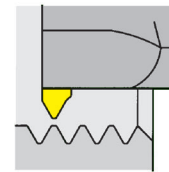

Metric trapezoidal thread
Internal

Toolholder
356

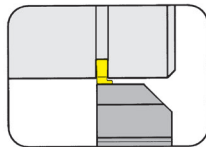

Page
P3-P7, P10

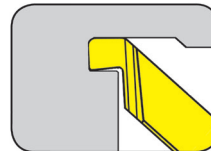

Page
P20

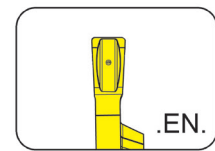

Page
P30

Toolholder
357

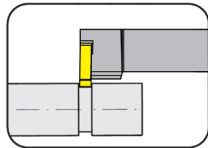

Page
P8-P9

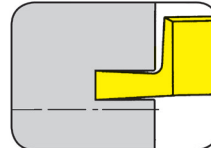

Page
P21-P22

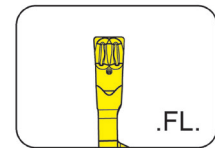

Page
P31

Toolholder
356

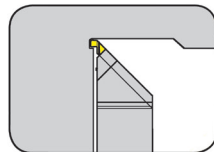

Page
P11

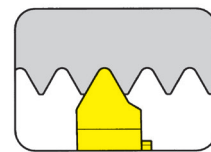

Page
P23

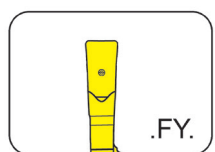

Page
P32

Toolholder
333

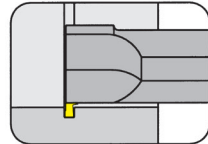

Page
P12-P13

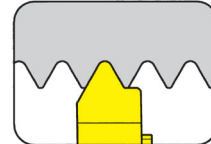

Page
P24, P27

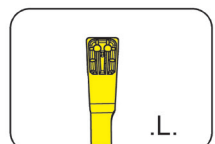

Page
P33

Cartridge
357

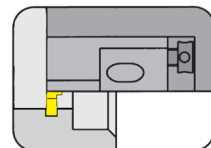

Page
P14-P15

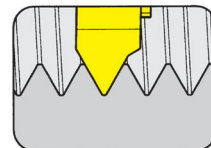

Page
P25

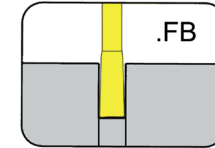

Page
P34

Indexable Insert
315/A315/S315

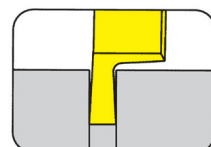

Page
P16-P18

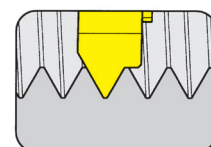

Page
P26

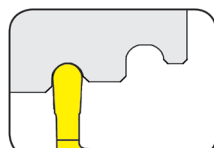

Page
P19

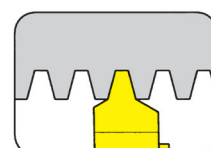

Page
P28

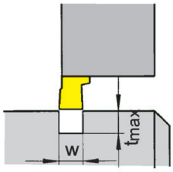

$w = .059 - .118"$
 (1.5 - 3.0 mm)
 $t_{max} = 0.315"$ (8.0 mm)



Toolholder
H316

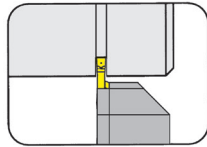

Page
Q3-Q5, Q10

Toolholder
HC316

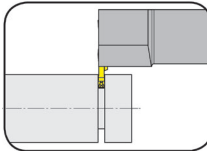

Page
Q6, Q11

Indexable Insert
S316

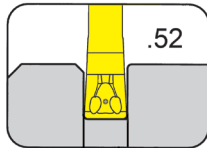

Page
Q7

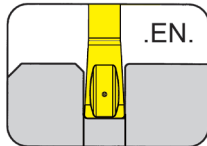

Page
Q8

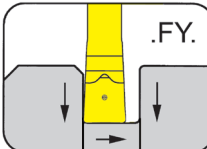

Page
Q9

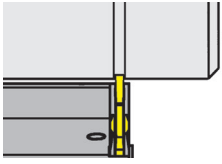

$w = .02 - .118" (0.5 - 3.0 \text{ mm})$
 $t_{\text{max}} = .217" (5.5 \text{ mm})$

Toolholder
H64T

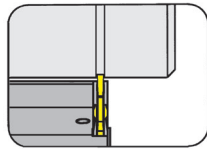

Page
R3-R4

Indexable Insert
S64T

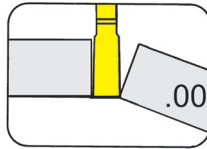

Page
R5

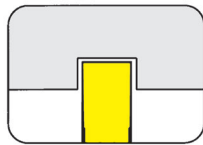

Page
R6

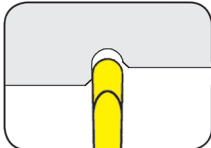

Page
R7

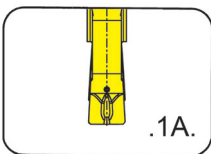

Page
R8

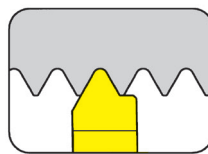

Page
R11

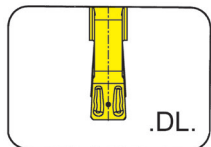

Page
R9

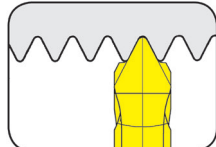

Page
R12

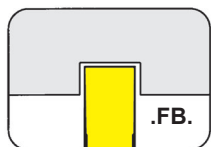

Page
R10

R



100/101

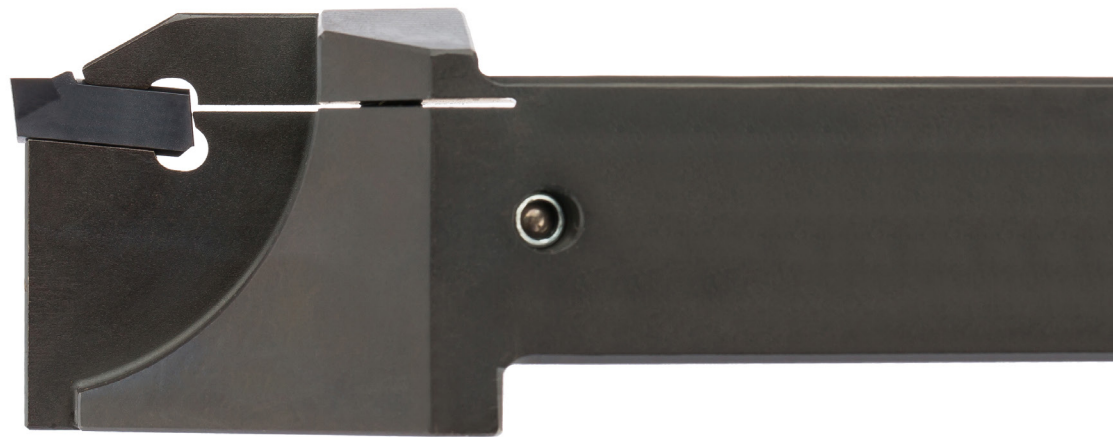

Cutter body with Inserts

Width of groove .047 - .630"

Depth of groove up to 2.165"

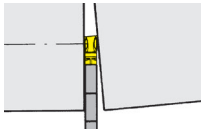

System 100
 $t_{max} = \leq 2.165''$ (55 mm)

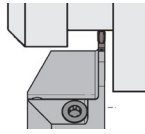

System 101
 $t_{max} = \leq .512''$ (13 mm)

Toolholder
 H100/HU100

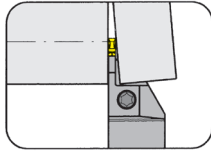

Page
 A3-A16, A19, A21

Toolholder
 H101

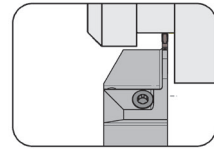

Page
 A41

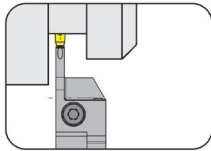

Page
 A17-A18, A20, A22, A23-A27

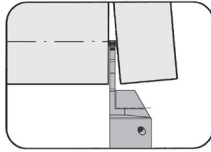

Page
 A35-A38

Insert
 S100/S101

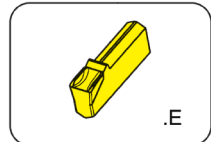

Page
 A28

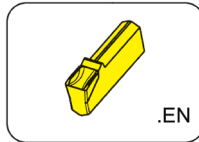

Page
 A29, A41

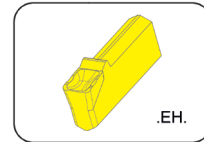

Page
 A30

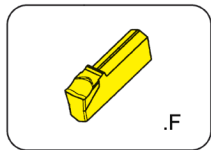

Page
 A32

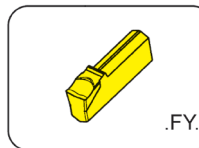

Page
 A33

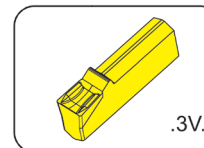

Page
 A34, A42

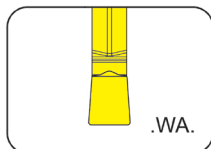

Page
 A35

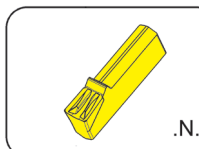

Page
 A36

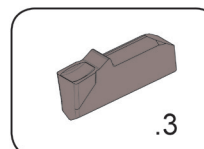

Page
 A44

Toolholder

HU100

with screwed clamping

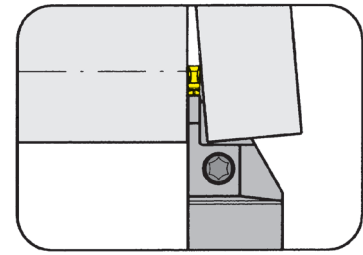

Depth of groove up to .827"
Width of groove .079"

for Insert

Type S100

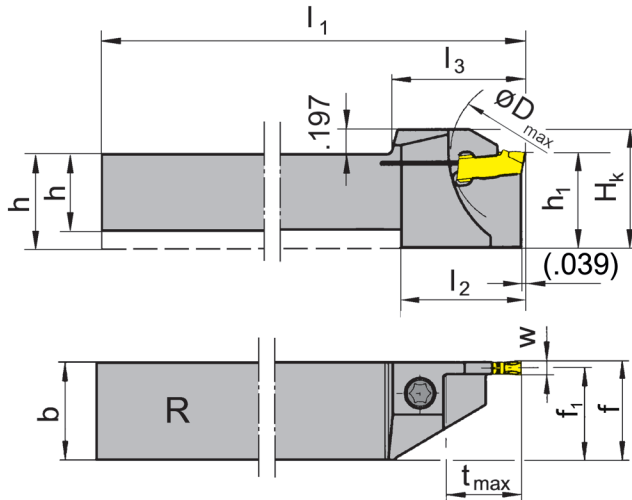

R = right hand version shown

L = left hand version

Part number	h	b	l ₁	l ₂	l ₃	h ₁	f ₁	f	t _{max}	D _{max}	H _K	Form	Size
R/LHU100.0375.01	.375	.375	5.118	.748	.827	.512	.345	f ₁ +w/2	.413	.827	.709	A	01
R/LHU100.0500.01	.500	.500	5.118	.827	.906	.625	.470	f ₁ +w/2	.512	1.024	.822	A	01
R/LHU100.0500.11	.500	.500	5.118	.827	1.024	.625	.470	f ₁ +w/2	.630	1.654	.822	A	01
R/LHU100.0625.11	.625	.625	5.118	.945	1.024	.750	.595	f ₁ +w/2	.630	1.654	.947	A	01
R/LHU100.0625.21	.625	.625	5.118	1.181	1.319	.750	.595	f ₁ +w/2	.827	1.654	.947	A	01
R/LHU100.0750.11	.750	.750	5.118	-	1.024	.750	.720	f ₁ +w/2	.630	1.654	.947	A	01
R/LHU100.0750.21	.750	.750	5.118	-	1.319	.750	.720	f ₁ +w/2	.827	1.654	.947	A	01
LHU100.1000.21	1.000	1.000	6.004	-	1.319	1.000	.972	f ₁ +w/2	.827	1.654	1.197	A	01

State R or L version

w see inserts

Dimensions in inch

Further sizes upon request

For torque specification of the screw, please see Technical Instructions.

Spare Parts

Toolholder	Clamping Screw	TORX PLUS® Wrench
R/LHU100...	4.15T15P	T15PQ

Toolholder

HU100

with screwed clamping

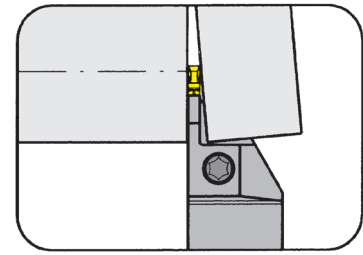
Depth of groove up to
Width of groove.846"
.079"

for Insert

Type S100

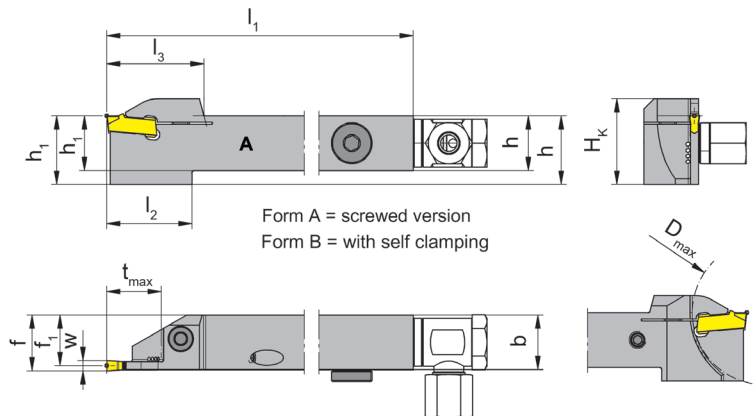

with through coolant supply

R = right hand version shown

L = left hand version

Part number	h	b	l ₁	l ₂	l ₃	h ₁	f ₁	f	t _{max}	D _{max}	H _K	Form	Size
R/LHU100.0500.01.IK	.500	.500	5.118	.827	.906	.630	.470	f ₁ +w/2	.531	1.024	.827	A	01
R/LHU100.0500.11.IK	.500	.500	5.118	.945	1.024	.630	.470	f ₁ +w/2	.630	1.654	.827	A	01
R/LHU100.0625.11.IK	.625	.625	5.118	.984	1.122	.787	.595	f ₁ +w/2	.630	1.654	.984	A	01
R/LHU100.0625.21.IK	.625	.625	5.118	1.181	1.319	.787	.595	f ₁ +w/2	.827	1.654	.984	A	01
R/LHU100.0750.11.IK	.750	.750	5.118	-	1.024	.750	.720	f ₁ +w/2	.630	1.654	.947	A	01
RHU100.0750.21.IK	.750	.750	5.118	-	1.319	.750	.720	f ₁ +w/2	.846	1.654	.947	A	01

State R or L version

w see inserts

Dimensions in inch

Further sizes upon request

For torque specification of the screw, please see Technical Instructions.

Spare Parts

Toolholder	Clamping Screw	Coolant supply	TORX PLUS® Wrench	Threaded Pin	Sealing plug
R/LHU100.0500.01.IK	4.15T15P	004.00.16	T15PQ	18.05.913	
R/LHU100.0500.11.IK	4.15T15P	004.00.61	T15PQ	18.05.913	
R/LHU100.0625...	4.15T15P	004.00.16	T15PQ	18.05.913	
R/LHU100.0750.11.IK	4.15T15P	004.00.16	T15PQ	18.08.913	
RHU100.0750.21.IK	4.15T15P	004.00.16	T15PQ		004.00.26

Toolholder

H100

with screwed clamping

Depth of groove up to
Width of groove

21 mm
2 mm

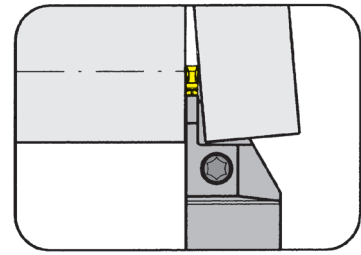

for Insert

Type S100

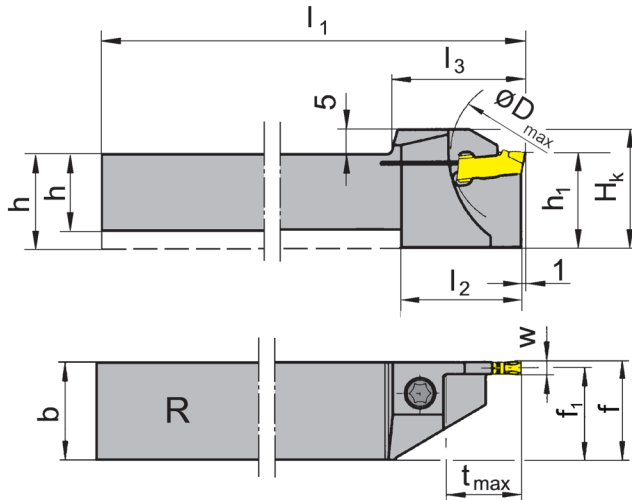

R = right hand version shown

L = left hand version

Part number	h	b	l_1	l_2	l_3	h_1	f_1	f	t_{max}	D_{max}	H_K	Size
R/LH100.1010.01	10	10	125	19	21.0	13	9.25	$f_1+w/2$	10.5	21	18	01
R/LH100.1010.11	10	10	125	21	23.0	16	9.25	$f_1+w/2$	13.0	42	21	01
R/LH100.1212.01	12	12	125	21	23.0	16	11.25	$f_1+w/2$	13.0	26	21	01
R/LH100.1212.11	12	12	125	21	26.0	16	11.25	$f_1+w/2$	16.0	42	21	01
R/LH100.1616.11	16	16	125	24	26.0	20	15.25	$f_1+w/2$	16.0	42	25	01
R/LH100.1616.21	16	16	125	30	33.5	20	15.25	$f_1+w/2$	21.0	42	25	01
R/LH100.2020.11	20	20	125	-	33.5	20	19.25	$f_1+w/2$	16.0	42	25	01
R/LH100.2020.21	20	20	125	-	33.5	20	19.25	$f_1+w/2$	21.0	42	25	01
R/LH100.2525.21	25	25	150	-	33.5	25	24.30	$f_1+w/2$	21.0	42	30	01

State R or L version

w see inserts

Dimensions in mm

Further sizes upon request

For torque specification of the screw, please see Technical Instructions.

Spare Parts

Toolholder	Clamping Screw	TORX PLUS® Wrench
R/LH100...	4.15T15P	T15PQ

Toolholder

H100

with screwed clamping

Depth of groove up to
Width of groove

21 mm
2 mm

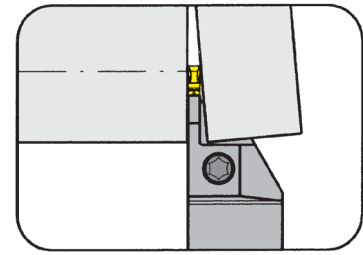

for Insert

Type S100

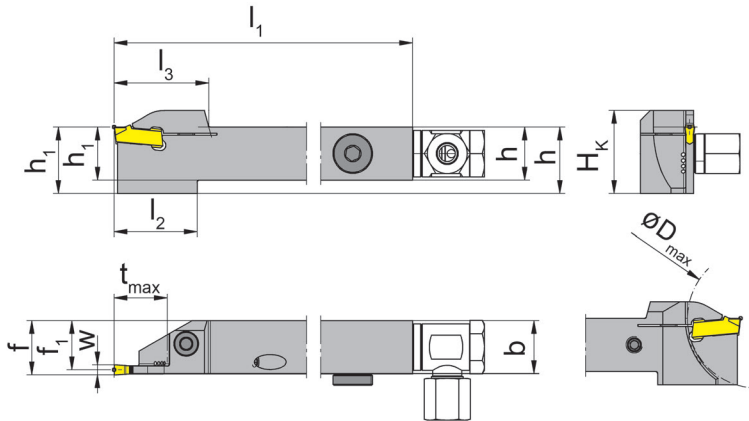

R = right hand version shown

L = left hand version

with through coolant supply

Part number	h	b	l_1	l_2	l_3	h_1	f_1	f	t_{max}	D_{max}	H_k	Size
R/LH100.1212.01.IK	12	12	125	21	23.0	12	11.25	$f_1+w/2$	13	26	21	01
R/LH100.1212.11.IK	12	12	125	21	26.0	12	11.25	$f_1+w/2$	16	42	21	01
R/LH100.1616.11.IK	16	16	125	24	26.0	16	15.25	$f_1+w/2$	16	42	25	01
R/LH100.1616.21.IK	16	16	125	30	33.5	16	15.25	$f_1+w/2$	21	42	25	01
R/LH100.2020.11.IK	20	20	125	-	33.5	20	19.25	$f_1+w/2$	16	42	25	01
R/LH100.2020.21.IK	20	20	125	-	33.5	20	19.25	$f_1+w/2$	21	42	25	01
R/LH100.2525.21.IK	25	25	150	-	33.5	25	24.30	$f_1+w/2$	21	42	30	01

State R or L version

w see inserts

Dimensions in mm

Further sizes upon request

For torque specification of the screw, please see Technical Instructions.

Spare Parts

Toolholder	Clamping Screw	Coolant supply	TORX PLUS® Wrench	Sealing plug	Threaded Pin
R/LH100.1212...	4.15T15P	004.00.61	T15PQ		
R/LH100...	4.15T15P	004.00.16	T15PQ	004.00.26	18.05.913

Toolholder

HU100

with screwed clamping

Depth of groove up to
Width of groove

1.28"
.079"

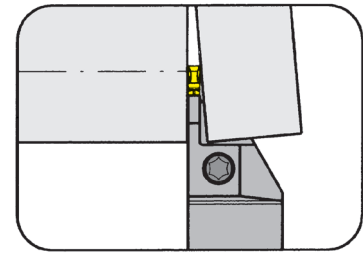

for Insert

Type S100

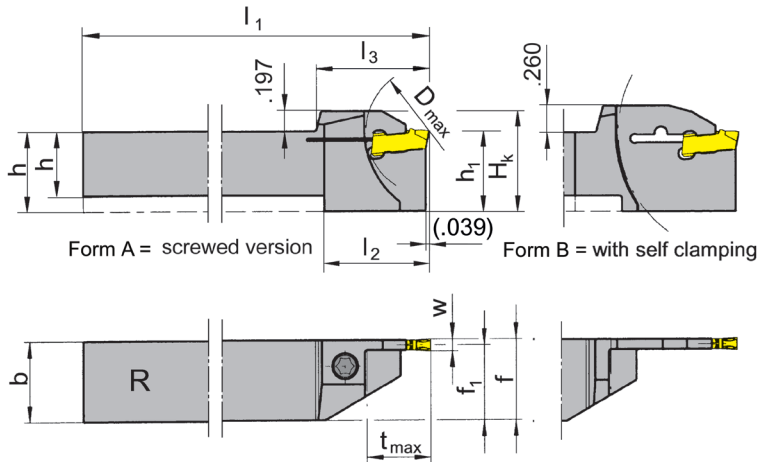

R = right hand version shown

L = left hand version

Part number	h	b	l ₁	l ₂	l ₃	h ₁	f ₁	f	t _{max}	D _{max}	H _k	Form	Size
R/LHU100.0500.02	.500	.500	5.118	.827	.906	.625	.463	f ₁ +w/2	.512	.984	.822	A	02
R/LHU100.0500.12	.500	.500	5.118	.945	1.024	.750	.463	f ₁ +w/2	.630	1.654	.947	A	02
R/LHU100.0625.02	.625	.625	5.118	.748	.827	.750	.588	f ₁ +w/2	.413	1.654	.947	A	02
R/LHU100.0625.12	.625	.625	5.118	.945	1.024	.750	.588	f ₁ +w/2	.630	1.654	.947	A	02
R/LHU100.0625.22	.625	.625	5.118	1.181	1.319	.750	.588	f ₁ +w/2	.827	1.654	.947	A	02
R/LHU100.0750.12	.750	.750	5.118	-	1.024	.750	.713	f ₁ +w/2	.630	1.654	.947	A	02
R/LHU100.0750.22	.750	.750	5.118	-	1.319	.750	.713	f ₁ +w/2	.827	1.654	.947	A	02
R/LHU100.0750.32	.750	.750	5.118	1.378	1.516	1.000	.713	f ₁ +w/2	1.280	2.559	1.260	B	02

State R or L version

w see inserts

Dimensions in inch

Further sizes upon request

For torque specification of the screw, please see Technical Instructions.

Wrench **P39L** is not combined with blade - separate order required!

Spare Parts

Toolholder	Clamping Screw	TORX PLUS® Wrench	Wrench
R/LHU100....	4.15T15P	T15PQ	
R/LHU100.0750.32			P39L

Toolholder

HU100

with screwed clamping

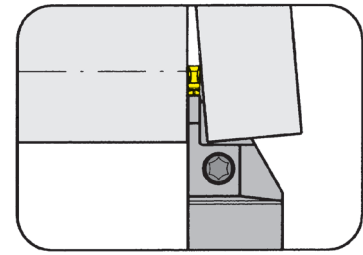
Depth of groove up to
Width of groove.846"
.098"

for Insert

Type S100

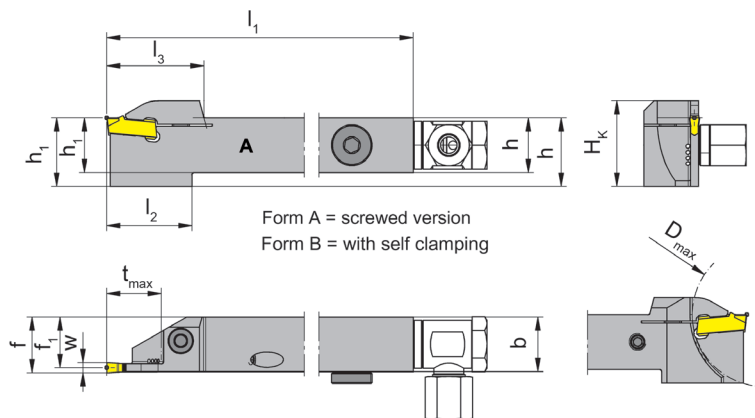

with through coolant supply

R = right hand version shown

L = left hand version

Part number	h	b	l ₁	l ₂	l ₃	h ₁	f ₁	f	t _{max}	D _{max}	H _K	Form	Size
R/LHU100.0500.02.IK	.500	.500	4.921	.827	.906	.630	.463	f ₁ +w/2	.531	1.024	.827	A	02
R/LHU100.0500.12.IK	.500	.500	5.118	.984	1.122	.630	.463	f ₁ +w/2	.630	1.654	.827	A	02
R/LHU100.0625.02.IK	.625	.625	5.118	.768	.906	.787	.588	f ₁ +w/2	.413	1.654	.984	A	02
R/LHU100.0625.12.IK	.625	.625	5.118	.984	1.122	.787	.588	f ₁ +w/2	.630	1.654	.984	A	02
R/LHU100.0750.12.IK	.750	.750	5.118	-	1.024	.750	.713	f ₁ +w/2	.630	1.654	.947	A	02
R/LHU100.1000.22.IK	1.000	1.000	5.906	-	1.319	1.000	.963	f ₁ +w/2	.846	1.654	1.197	A	02
RHU100.0625.22.IK	.625	.625	5.118	1.181	1.319	.787	.588	f ₁ +w/2	.846	1.654	.984	A	02
RHU100.0750.22.IK	.750	.750	5.118	-	1.319	.750	.713	f ₁ +w/2	.846	1.654	.947	A	02

State R or L version

w see inserts

Dimensions in inch

Further sizes upon request

For torque specification of the screw, please see Technical Instructions.

Spare Parts

Toolholder	Clamping Screw	Coolant supply	TORX PLUS® Wrench	Sealing plug	Threaded Pin
R/LHU100.0500...	4.15T15P	004.00.61	T15PQ		
R/LHU100.0625...	4.15T15P	004.00.16	T15PQ	004.00.26	18.05.913
R/LHU100.0750.12.IK	4.15T15P	004.00.16	T15PQ		18.08.913
RHU100.0750.22.IK	5.17T20P	004.00.16	T20PQ	004.00.26	18.05.913
RHU100.1000.22.IK	4.15T15P	004.00.16	T15PQ	004.00.26	18.05.913

Toolholder

H100

with screwed clamping

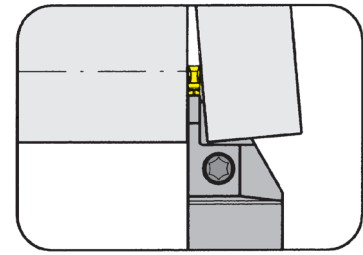

Depth of groove up to 1.28"
Width of groove .098"

for Insert

Type S100

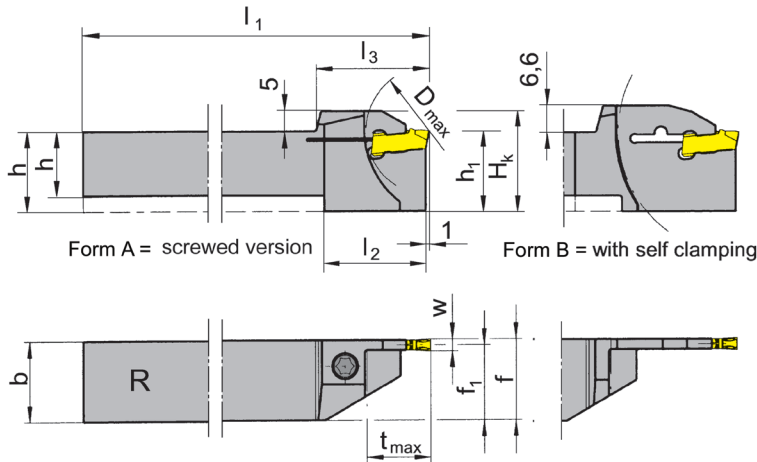

R = right hand version shown

L = left hand version

Part number	h	b	l ₁	l ₂	l ₃	h ₁	f ₁	f	t _{max}	D _{max}	H _K	Form	Size
R/LH100.1212.02	12	12	125	21	23.0	16	11.05	f ₁ +w/2	13.0	25	21.0	A	02
R/LH100.1616.02	16	16	125	19	21.0	20	15.05	f ₁ +w/2	10.5	42	25.0	A	02
R/LH100.1212.12	12	12	125	24	26.0	16	11.05	f ₁ +w/2	16.0	42	25.0	A	02
R/LH100.1616.12	16	16	125	24	26.0	20	15.05	f ₁ +w/2	16.0	42	25.0	A	02
R/LH100.2020.12	20	20	125	-	26.0	20	19.05	f ₁ +w/2	16.0	42	25.0	A	02
R/LH100.1616.22	16	16	125	30	33.5	20	15.05	f ₁ +w/2	21.0	42	25.0	A	02
R/LH100.2020.22	20	20	125	-	33.5	20	19.05	f ₁ +w/2	21.0	42	25.0	A	02
R/LH100.2525.22	25	25	150	-	33.5	25	24.05	f ₁ +w/2	21.0	42	30.0	A	02
R/LH100.2020.32	20	20	125	35	38.5	25	19.05	f ₁ +w/2	32.5	65	31.6	B	02

State R or L version

w see inserts

Dimensions in mm

Further sizes upon request

Ordering note:

Wrench **P39L** is not combined with blade R/LH100.2020.32 - separate order required!

For torque specification of the screw, please see Technical Instructions.

Spare Parts

Toolholder	Clamping Screw	TORX PLUS® Wrench	Wrench
R/LH100...	4.15T15P	T15PQ	
R/LH100.2020.32			P39L

Toolholder

H100

with screwed clamping

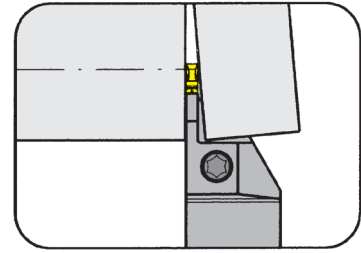
Depth of groove up to
Width of groove21 mm
2.5 mm

for Insert

Type S100

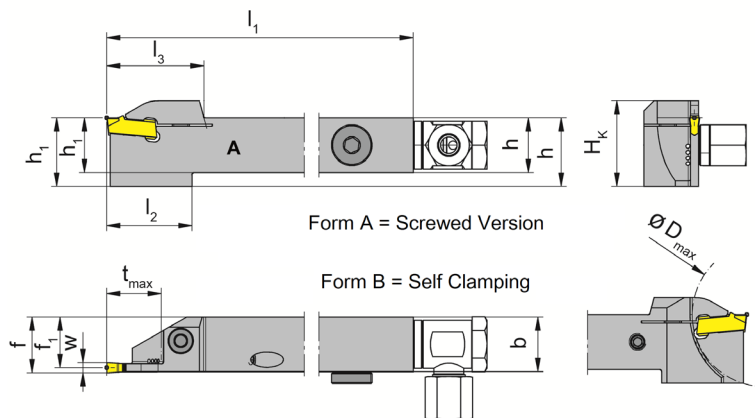

Form A = Screwed Version

Form B = Self Clamping

R = right hand version shown

L = left hand version

with through coolant supply

Part number	h	b	l ₁	l ₂	l ₃	h ₁	f ₁	f	t _{max}	D _{max}	H _K	Form	Size
R/LH100.1212.02.IK	12	12	125	21	23.0	16	11.05	f ₁ +w/2	13.0	25	21	A	02
R/LH100.1616.02.IK	16	16	125	19	21.0	20	15.05	f ₁ +w/2	10.5	42	25	A	02
R/LH100.1212.12.IK	12	12	125	24	26.0	16	11.05	f ₁ +w/2	16.0	42	25	A	02
R/LH100.1616.12.IK	16	16	125	24	28.5	20	15.05	f ₁ +w/2	16.0	42	25	A	02
R/LH100.2020.12.IK	20	20	125	-	26.0	20	19.05	f ₁ +w/2	16.0	42	25	A	02
R/LH100.1616.22.IK	16	16	125	30	33.5	20	15.05	f ₁ +w/2	21.0	42	25	A	02
R/LH100.2020.22.IK	20	20	125	-	33.5	20	19.05	f ₁ +w/2	21.0	42	25	A	02
R/LH100.2525.22.IK	25	25	150	-	33.5	25	24.05	f ₁ +w/2	21.0	42	30	A	02

State R or L version

w see inserts

Dimensions in mm

Further sizes upon request

For torque specification of the screw, please see Technical Instructions.

Spare Parts

Toolholder	Clamping Screw	Coolant supply	TORX PLUS® Wrench	Sealing plug	Threaded Pin
R/LH100.1212.02/.12.IK	4.15T15P	004.00.61	T15PQ		
R/LH100.1616...02/.12.IK	4.15T15P	004.00.16	T15PQ	004.00.26	18.05.913
R/LH100.2020.12.IK	4.15T15P	004.00.16	T15PQ	004.00.26	18.05.913
R/LH100.2020.22.IK	5.17T20P	004.00.16	T20PQ	004.00.26	18.05.913
R/LH100.2525.22.IK	4.15T15P	004.00.16	T15PQ	004.00.26	18.05.913

Toolholder

HU100

with screwed clamping

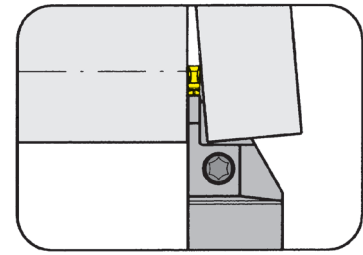

Depth of groove up to
Width of groove

1.28"
.118"

for Insert

Type S100

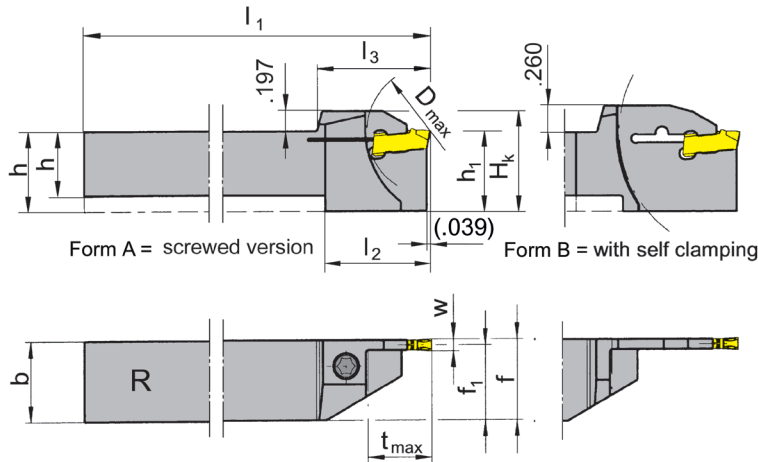

R = right hand version shown

L = left hand version

Part number	h	b	l ₁	l ₂	l ₃	h ₁	f ₁	f	t _{max}	D _{max}	H _K	Form	Size
R/LHU100.0500.03	.500	.500	5.118	.827	.906	.625	.455	f ₁ +w/2	.512	1.024	.822	A	03
R/LHU100.0625.03	.625	.625	5.118	.768	.906	.750	.580	f ₁ +w/2	.413	1.654	.947	A	03
R/LHU100.0625.13	.625	.625	5.118	.984	1.122	.750	.580	f ₁ +w/2	.630	1.654	.947	A	03
R/LHU100.0625.23	.625	.625	5.118	1.181	1.319	.750	.580	f ₁ +w/2	.827	1.654	.947	A	03
R/LHU100.0750.13	.750	.750	5.118	-	1.122	.750	.705	f ₁ +w/2	.630	1.654	.947	A	03
R/LHU100.0750.23	.750	.750	5.118	-	1.319	.750	.705	f ₁ +w/2	.827	1.654	.947	A	03
R/LHU100.0750.33	.750	.750	5.118	1.378	1.516	1.000	.705	f ₁ +w/2	1.280	2.559	1.260	B	03
R/LHU100.1000.13	1.000	1.000	6.004	-	1.122	1.000	.955	f ₁ +w/2	.630	1.654	1.197	A	03
R/LHU100.1000.23	1.000	1.000	6.004	-	1.319	1.000	.955	f ₁ +w/2	.827	1.654	1.197	A	03
R/LHU100.1000.33	1.000	1.000	6.004	-	1.516	1.000	.955	f ₁ +w/2	1.280	2.559	1.260	B	03

State R or L version

w see inserts

Dimensions in inch

Further sizes upon request

For torque specification of the screw, please see Technical Instructions.

Wrench **P39L** is not combined with blade - separate order required!

Spare Parts

Toolholder	Clamping Screw	TORX PLUS® Wrench	Wrench
R/LHU100...	5.17T20P	T20PQ	
R/LHU100...33			P39L

Toolholder

HU100

with screwed clamping

Depth of groove up to
Width of groove

1.299"
.118"

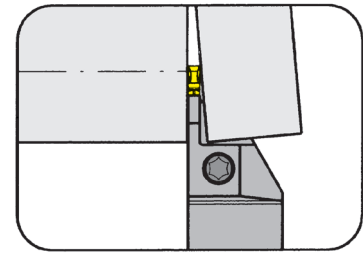

for Insert

Type S100

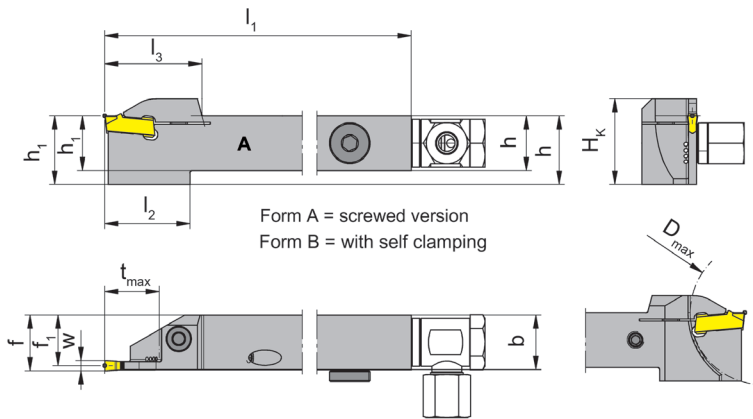

with through coolant supply

R = right hand version shown

L = left hand version

Part number	h	b	l ₁	l ₂	l ₃	h ₁	f ₁	f	t _{max}	D _{max}	H _K	Form	Size
R/LHU100.0500.03.IK	.500	.500	5.118	.846	.925	.630	.455	f ₁ +w/2	.531	1.024	.827	A	03
R/LHU100.0625.13.IK	.625	.625	5.118	.984	1.122	.787	.580	f ₁ +w/2	.630	1.654	.984	A	03
R/LHU100.0625.23.IK	.625	.625	5.118	1.181	1.319	.787	.580	f ₁ +w/2	.827	1.654	.984	A	03
R/LHU100.0750.13.IK	.750	.750	5.118	-	1.122	.750	.705	f ₁ +w/2	.630	1.654	.947	A	03
R/LHU100.0750.23.IK	.750	.750	4.921	-	1.319	.750	.705	f ₁ +w/2	.846	1.654	.947	A	03
R/LHU100.0750.33.IK	.750	.750	5.118	1.378	1.516	.984	.705	f ₁ +w/2	1.299	2.559	1.244	B	03
R/LHU100.1000.13.IK	1.000	1.000	6.004	-	1.122	1.000	.955	f ₁ +w/2	.630	1.654	1.197	A	03
R/LHU100.1000.33.IK	1.000	1.000	6.004	-	1.516	1.000	.955	f ₁ +w/2	1.299	2.559	1.260	B	03
RHU100.0625.03.IK	.625	.625	5.118	.768	.906	.787	.580	f ₁ +w/2	.413	1.654	.984	A	03
RHU100.1000.23.IK	1.000	1.000	5.906	-	1.319	1.000	.955	f ₁ +w/2	.846	1.654	1.197	A	03

State R or L version

w see inserts

Dimensions in inch

Further sizes upon request

Note:

Wrench P39L is not combined with blade - separate order required!

For torque specification of the screw, please see Technical Instructions.

Spare Parts

Toolholder	Clamping Screw	Coolant Supply	TORX PLUS® Wrench	Threaded Pin	Screw	Wrench	Sealing Plug
R/LHU100.0500.03.IK	5.17T20P	004.00.61	T20PQ				
R/LHU100.0625.13/.23.IK	5.17T20P	004.00.16	T20PQ	18.05.913			
R/LHU100.0750.13.IK	5.17T20P	004.00.16	T20PQ	18.08.913			
R/LHU100.0750.23.IK	5.17T20P	004.00.61	T20PQ		004.00.21		
R/LHU100...33.IK		004.00.16		18.08.913		P39L	
R/LHU100.1000.13.IK	5.17T20P	004.00.16	T20PQ	18.08.913			
R/LHU100.0625.03.IK	5.17T20P	004.00.16	T20PQ	18.05.913			004.00.26

Toolholder

H100

with screwed clamping

Depth of groove up to
Width of groove

32.5 mm
3 mm

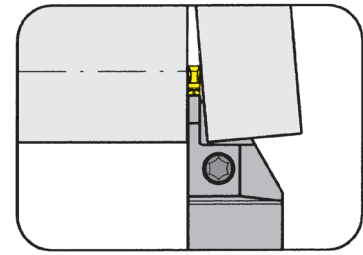

for Insert

Type S100

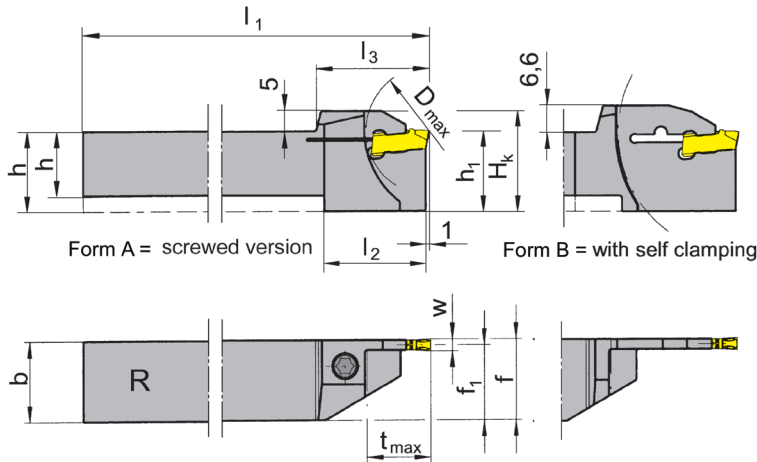

R = right hand version shown

L = left hand version

Part number	h	b	l ₁	l ₂	l ₃	h ₁	f ₁	f	t _{max}	D _{max}	H _K	Form	Size
R/LH100.1212.03	12	12	125	21.0	23.0	16	10.85	f ₁ +w/2	13.0	26	25.0	A	03
R/LH100.1616.03	16	16	125	19.5	23.0	20	14.85	f ₁ +w/2	10.5	42	25.0	A	03
R/LH100.1616.13	16	16	125	25.0	28.5	20	14.85	f ₁ +w/2	16.0	42	25.0	A	03
R/LH100.1616.23	16	16	125	30.0	33.5	20	14.85	f ₁ +w/2	21.0	42	25.0	A	03
R/LH100.2020.13	20	20	125	-	28.5	20	18.85	f ₁ +w/2	16.0	42	25.0	A	03
R/LH100.2020.23	20	20	125	-	33.5	20	18.85	f ₁ +w/2	21.0	42	25.0	A	03
R/LH100.2020.33	20	20	125	35.0	38.5	25	18.85	f ₁ +w/2	32.5	65	31.6	B	03
R/LH100.2525.13	25	25	150	-	28.5	25	23.85	f ₁ +w/2	16.0	42	30.0	A	03
R/LH100.2525.23	25	25	150	-	33.5	25	23.85	f ₁ +w/2	21.0	42	30.0	A	03
R/LH100.2525.33	25	25	150	-	38.5	25	23.85	f ₁ +w/2	32.5	65	31.6	B	03

State R or L version

w see inserts

Dimensions in mm

Further sizes upon request

Ordering note:

Wrench **P39L** is not combined with blade R/LH100...33 - separate order required!

For torque specification of the screw, please see Technical Instructions.

Spare Parts

Toolholder	Clamping Screw	TORX PLUS® Wrench
R/LH100...03/.13/.23	5.17T20P	T20PQ
R/LH100...33		P39L

Toolholder

H100

with screwed clamping

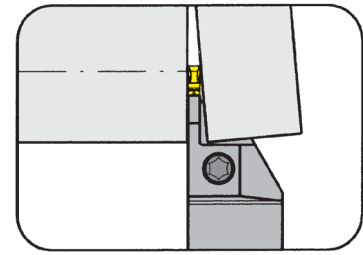
Depth of groove up to
Width of groove32.5 mm
3 mm

for Insert

Type S100

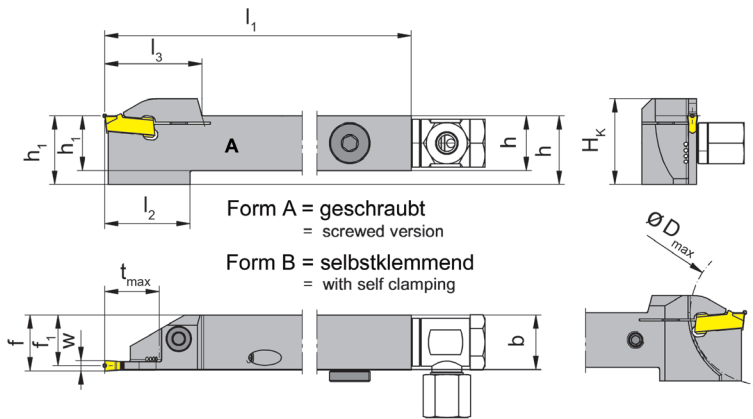

with through coolant supply

R = right hand version shown

L = left hand version

Part number	h	b	l ₁	l ₂	l ₃	h ₁	f ₁	f	t _{max}	D _{max}	H _K	Form	Size
R/LH100.1212.03.IK	12	12	125	21.0	23.0	16	10.85	f ₁ +w/2	13.0	26	25.0	A	03
R/LH100.1616.03.IK	16	16	125	19.5	23.0	20	14.85	f ₁ +w/2	10.5	42	25.0	A	03
R/LH100.1616.13.IK	16	16	125	25.0	28.5	20	14.85	f ₁ +w/2	16.0	42	25.0	A	03
R/LH100.2020.13.IK	20	20	125	-	28.5	20	18.85	f ₁ +w/2	16.0	42	25.0	A	03
R/LH100.2525.13.IK	25	25	150	-	28.5	25	23.85	f ₁ +w/2	16.0	42	30.0	A	03
R/LH100.1616.23.IK	16	16	125	30.0	33.5	20	14.85	f ₁ +w/2	21.0	42	25.0	A	03
R/LH100.2020.23.IK	20	20	125	-	33.5	20	18.85	f ₁ +w/2	21.0	42	25.0	A	03
R/LH100.2525.23.IK	25	25	150	-	33.5	25	23.85	f ₁ +w/2	21.0	42	30.0	A	03
R/LH100.2020.33.IK	20	20	125	35.0	38.5	25	18.85	f ₁ +w/2	32.5	65	31.6	B	03
R/LH100.2525.33.IK	25	25	150	-	38.5	25	23.85	f ₁ +w/2	32.5	65	31.6	B	03

State R or L version

w see inserts

Dimensions in mm

Further sizes upon request

Note:Wrench **P39L** is not combined with blade R/LH100...33 - separate order required!

For torque specification of the screw, please see Technical Instructions.

Spare Parts

Toolholder	Clamping Screw	Coolant supply	TORX PLUS® Wrench	Sealing Plug	Threaded Pin	Screw	Wrench
R/LH100.1212.03.IK	5.17T20P	004.00.61	T20PQ				
R/LH100.1616.03.IK	5.17T20P	004.00.16	T20PQ	004.00.26	18.05.913		
R/LH100...13/.23.IK	5.17T20P	004.00.16	T20PQ	004.00.26	18.05.913		
R/LH100.2525.23.IK	5.17T20P	004.00.61	T20PQ		4.06.913	004.00.21	
R/LH100...33.IK		004.00.16		004.00.26	18.05.913		P39L

Toolholder

HU100

with screwed clamping

Depth of groove up to
Width of groove

1.594"
.079"

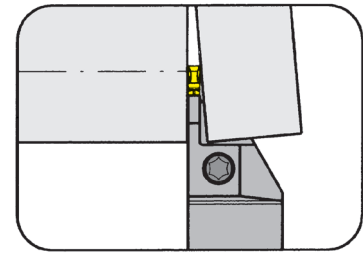

for Insert

Type S100

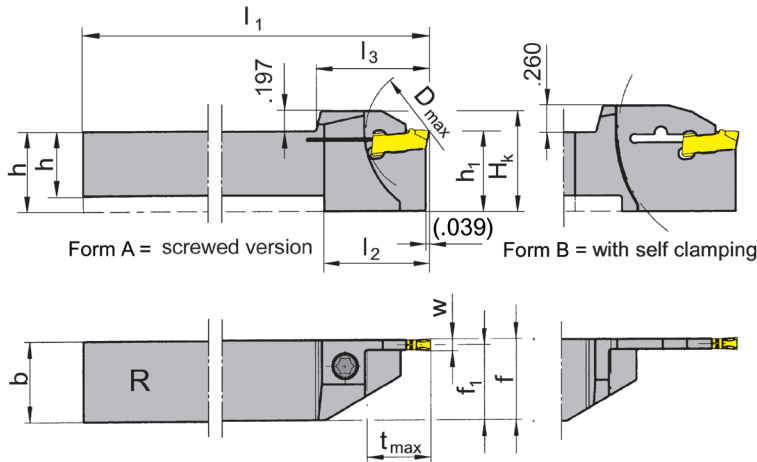

R = right hand version shown

L = left hand version

Part number	h	b	l_1	l_2	l_3	h_1	f_1	f	t_{max}	D_{max}	H_K	Form	Size
R/LHU100.0625.24	.625	.625	5.118	1.181	1.319	.750	.564	$f_1+w/2$.827	1.654	.947	A	04
R/LHU100.0750.14	.750	.750	5.118	-	1.122	.750	.689	$f_1+w/2$.630	1.654	.947	A	04
R/LHU100.0750.34	.750	.750	5.118	1.378	1.516	1.000	.689	$f_1+w/2$	1.280	2.559	1.260	B	04
R/LHU100.1000.14	1.000	1.000	6.004	-	1.122	1.000	.939	$f_1+w/2$.630	1.654	1.197	A	04
R/LHU100.1000.34	1.000	1.000	6.004	1.575	1.831	1.250	.939	$f_1+w/2$	1.594	3.189	1.510	B	04
RHU100.0625.04	.625	.625	5.118	.768	.906	.750	.564	$f_1+w/2$.413	1.654	.947	A	04

State R or L version

w see inserts

Dimensions in inch

Further sizes upon request

For torque specification of the screw, please see Technical Instructions.

Wrench **P39L** is not combined with blade - separate order required!

Spare Parts

Toolholder	Clamping Screw	TORX PLUS® Wrench	Wrench
R/LHU100...14/24	5.17T20P	T20PQ	
R/LHU100...34			P39L

Toolholder

H100

with screwed clamping

Depth of groove up to
Width of groove

40.5 mm
4 mm

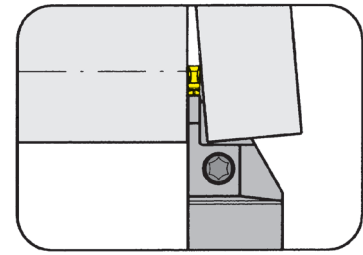

for Insert

Type S100

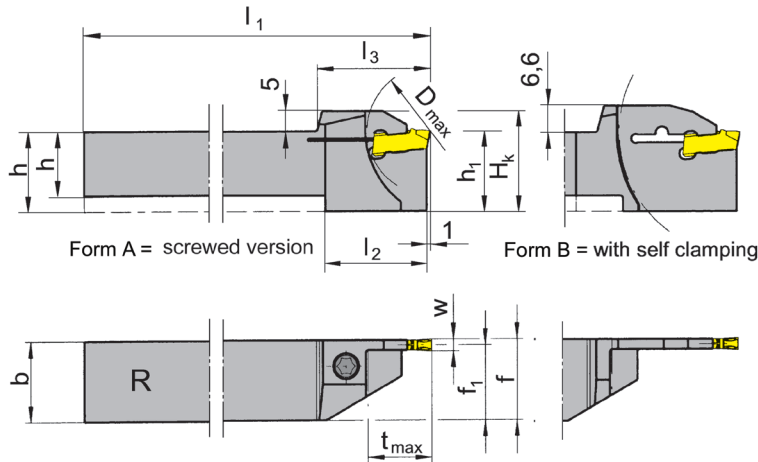

R = right hand version shown

L = left hand version

Part number	h	b	l ₁	l ₂	l ₃	h ₁	f ₁	f	t _{max}	D _{max}	H _K	Form	Size
R/LH100.1616.04	16	16	125	19.5	23.0	20	14.45	f ₁ +w/2	10.5	42	25.0	A	04
R/LH100.1616.14	16	16	125	25.0	28.5	20	14.45	f ₁ +w/2	16.0	42	25.0	A	04
R/LH100.2020.14	20	20	125	-	28.5	20	18.45	f ₁ +w/2	16.0	42	25.0	A	04
R/LH100.2525.14	25	25	150	-	28.5	25	23.45	f ₁ +w/2	16.0	42	30.0	A	04
R/LH100.1616.24	16	16	125	30.0	33.5	20	14.45	f ₁ +w/2	21.0	42	25.0	A	04
R/LH100.2020.34	20	20	125	35.0	38.5	25	18.45	f ₁ +w/2	32.5	65	31.6	B	04
R/LH100.2525.34	25	25	150	40.0	46.5	32	23.45	f ₁ +w/2	40.5	81	31.6	B	04

State R or L version

w see inserts

Dimensions in mm

Further sizes upon request

Ordering note:Wrench **P39L** is not combined with blade R/LH100...34 - separate order required!

For torque specification of the screw, please see Technical Instructions.

Spare Parts

Toolholder	Clamping Screw	TORX PLUS® Wrench	Wrench
R/LH100...04/.14/.24	5.17T20P	T20PQ	
R/LH100...34			P39L

Toolholder

HU100

with screwed clamping

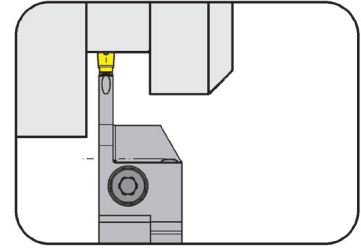

Depth of groove up to .846"
Width of groove .118 - .157"

for Insert

Type S100

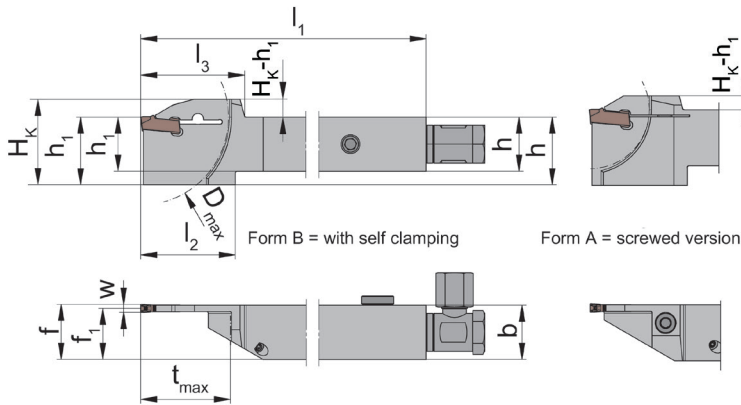

with through coolant supply

R = right hand version shown

L = left hand version

Part number	h	b	l ₁	l ₂	l ₃	h ₁	f ₁	f	t _{max}	D _{max}	H _K	Form	Size
R/LHU100.0625.0.23.IK	.625	.625	5.118	1.378	1.555	.984	.572	f ₁ +w/2	.846	1.654	1.339	A	03
R/LHU100.0750.0.23.IK	.750	.750	5.118	1.299	1.535	.984	.697	f ₁ +w/2	.846	1.654	1.339	A	03
RHU100.1000.0.23.IK	1.000	1.000	5.906	1.299	1.555	1.181	.947	f ₁ +w/2	.846	1.654	1.535	A	03
RHU100.0625.0.24.IK	.625	.625	5.118	1.378	1.555	.984	.560	f ₁ +w/2	.846	1.654	1.339	A	04

State R or L version

w see inserts

Dimensions in inch

Further sizes upon request

For torque specification of the screw, please see Technical Instructions.

Spare Parts

Toolholder	Sealing plug	Coolant supply	Clamping Screw	TORX PLUS® Wrench	Threaded Pin
R/LHU100.625.0.23/24.IK	004.00.26	004.00.16	6.23T25P	T25PQ	18.05.913
LHU100.0750.0.23.IK		004.00.16	6.23T25P	T25PQ	18.08.913
RHU100.1000.0.23.IK	004.00.26	004.00.16	6.23T25P	T25PQ	18.05.913

Toolholder

H100

with screwed clamping

Depth of groove up to
Width of groove

21.5 mm
3 - 4 mm

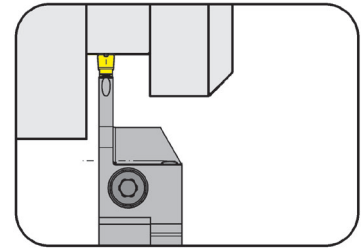

for Insert

Type S100

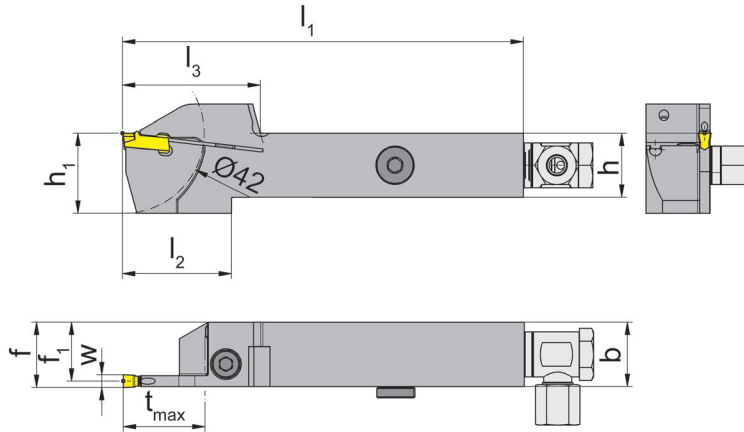

with through coolant supply

R = right hand version shown

L = left hand version

Part number	h	b	l ₁	l ₂	l ₃	h ₁	f ₁	f	t _{max}	Size
R/LH100.1616.0.23.IK	16	16	125	35	39	25	14.65	f ₁ +w/2	21.5	03
R/LH100.1616.0.24.IK	16	16	125	35	39	25	14.30	f ₁ +w/2	21.5	04
R/LH100.2020.0.23.IK	20	20	125	33	39	25	18.65	f ₁ +w/2	21.5	03
R/LH100.2020.0.24.IK	20	20	125	33	39	25	18.30	f ₁ +w/2	21.5	04
R/LH100.2525.0.23.IK	25	25	150	33	39	30	23.65	f ₁ +w/2	21.5	03
R/LH100.2525.0.24.IK	25	25	150	33	39	30	23.30	f ₁ +w/2	21.5	04

State R or L version

w see inserts

Dimensions in mm

Further sizes upon request

For torque specification of the screw, please see Technical Instructions.

Spare Parts

Toolholder	Sealing plug	Threaded Pin	Coolant supply	Clamping Screw	TORX PLUS® Wrench
R/LH100...23/24.IK	004.00.26	18.05.913	004.00.16	6.23T25P	T25PQ

Toolholder

HU100

with screwed clamping

Depth of groove up to .984"
Width of groove .157"

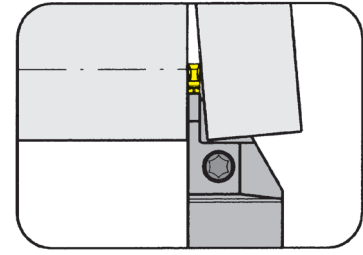

for Insert

Type S100

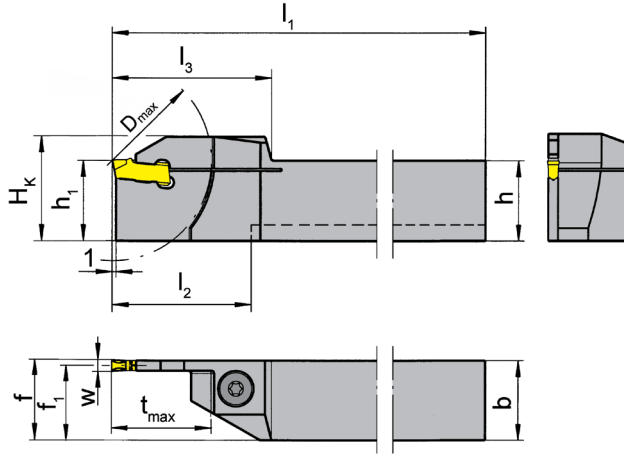

R = right hand version shown

L = left hand version

Part number	h	b	l ₁	l ₃	h ₁	f ₁	f	t _{max}	D _{max}	H _K	Form	Size
R/LHU100.0750.73	.750	.750	5.118	1.575	.750	.705	f ₁ +w/2	.984	1.969	.986	A	03
RHU100.1000.73	1.000	1.000	5.118	1.575	1.000	.955	f ₁ +w/2	.984	1.969	1.236	A	03
R/LHU100.0750.74	.750	.750	5.118	1.575	.750	.689	f ₁ +w/2	.984	1.969	.986	A	04

State R or L version

w see inserts

Dimensions in inch

Further sizes upon request

Spare Parts

Toolholder	Clamping Screw	TORX PLUS® Wrench
R/LHU100...	6.23T25P	T25PQ

Toolholder

HU100

with screwed clamping

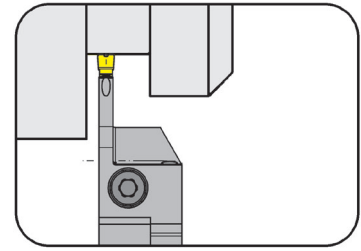
Depth of groove up to
Width of groove1.004"
.157"

for Insert

Type S100

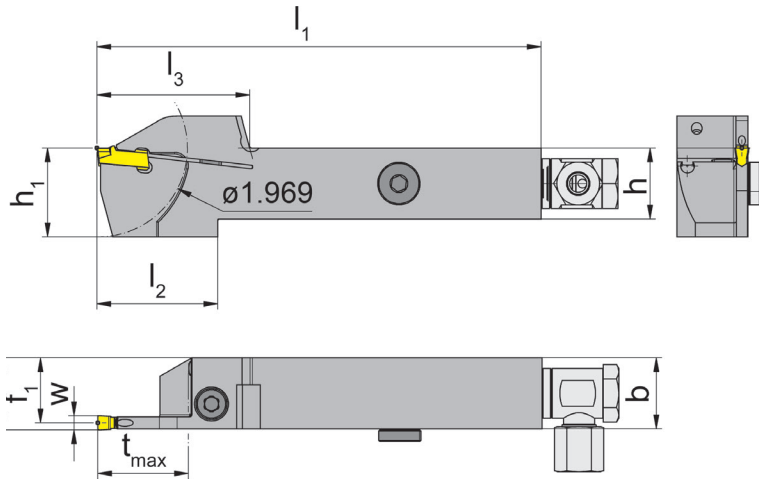

R = right hand version shown

L = left hand version

with through coolant supply

Part number	h	b	l ₁	l ₃	l ₂	h ₁	f ₁	t _{max}	D _{max}	H _K	Form	Size
R/LHU100.0750.0.73.IK	.750	.750	5.118	1.457	1.693	.984	.697	1.004	1.969	1.339	A	03
R/LHU100.1000.0.73.IK	1.000	1.000	6.004	1.457	1.693	1.181	.947	1.004	1.969	1.535	A	03
R/LHU100.0750.0.74.IK	.750	.750	5.118	1.457	1.693	.984	.683	1.004	1.969	1.339	A	04
R/LHU100.1000.0.74.IK	1.000	1.000	5.118	1.457	1.693	1.181	.933	1.004	1.969	1.535	A	04

State R or L version

w see inserts

Dimensions in inch

Further sizes upon request

Note: $f=f_1+w/2$ **Note:** Wrench **P39L** is not combined with blade R/LH100...33 - separate order required!

For torque specification of the screw, please see Technical Instructions.

Spare Parts

Toolholder	Sealing plug	Coolant supply	Clamping Screw	TORX PLUS® Wrench	Threaded Pin
R/LHU100.0750.0.73/.74.IK	004.00.26	004.00.16	6.23T25P	T25PQ	18.05.913
R/LHU100.1000.0.73.IK		004.00.16	6.23T25P	T25PQ	18.08.913
R/LHU100.1000.0.74.IK	004.00.26	004.00.16	6.23T25P	T25PQ	18.05.913

Toolholder

HU100

with screwed clamping

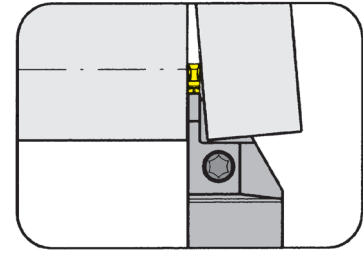

Depth of groove up to 1.594"
Width of groove .079"

for Insert

Type S100

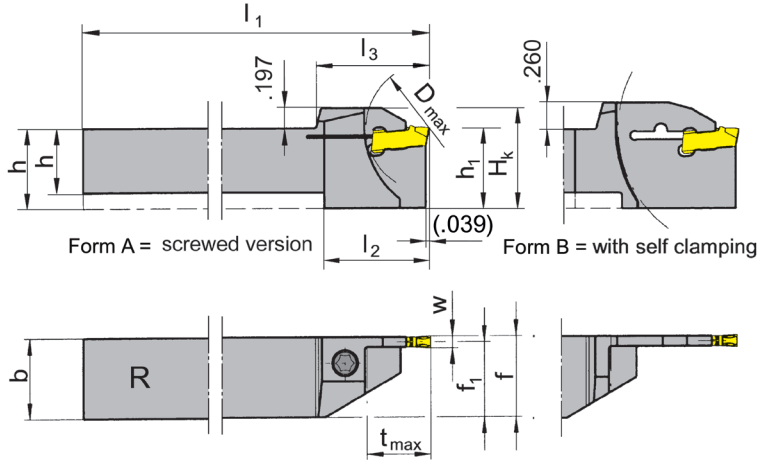

R = right hand version shown

L = left hand version

Part number	h	b	l ₁	l ₂	l ₃	h ₁	f ₁	t _{max}	D _{max}	H _K	Form	Size
R/LHU100.0750.15	.750	.750	5.118	-	1.122	.750	.673	.630	1.654	.947	A	05
R/LHU100.0750.35	.750	.750	5.118	1.378	1.516	1.000	.673	1.280	2.559	1.260	B	05
R/LHU100.1000.15	1.000	1.000	6.004	-	1.122	1.000	.923	.630	1.654	1.197	A	05
R/LHU100.1000.35	1.000	1.000	6.004	1.575	1.831	1.250	.923	1.594	3.189	1.510	B	05

State R or L version

w see inserts

Dimensions in inch

Further sizes upon request

Note: $f=f_1+w/2$

For torque specification of the screw, please see Technical Instructions.

Wrench **P39L** is not combined with blade - separate order required!

Spare Parts

Toolholder	Clamping Screw	TORX PLUS® Wrench	Wrench
R/LHU100...15	5.17T20P	T20PQ	
R/LHU100...35			P39L

Toolholder

H100

with screwed clamping

Depth of groove up to
Width of groove

40.5 mm
5 mm

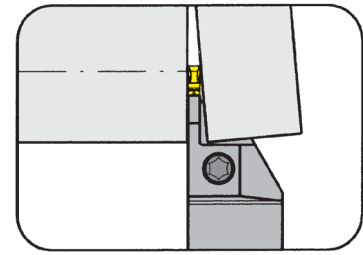

for Insert

Type S100

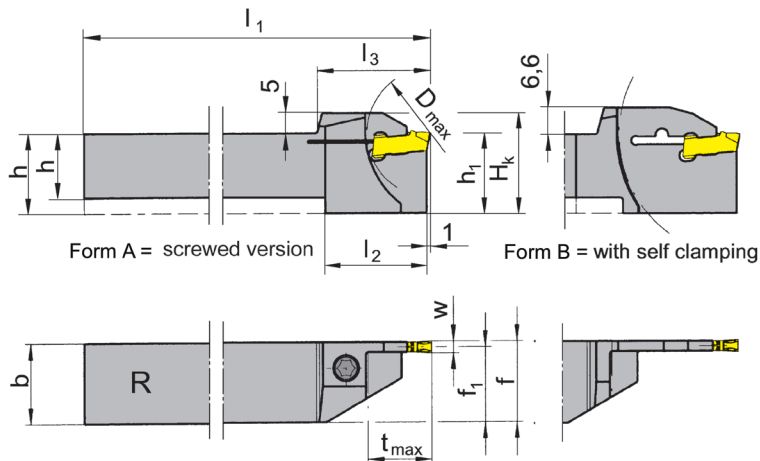

R = right hand version shown

L = left hand version

Part number	h	b	l ₁	l ₂	l ₃	h ₁	f ₁	f	t _{max}	D _{max}	H _K	Form	Size
R/LH100.2020.15	20	20	125	-	28.5	20	18.05	$f_1+w/2$	16.0	42	25.0	A	05
R/LH100.2525.15	25	25	150	-	28.5	25	23.05	$f_1+w/2$	16.0	42	30.0	A	05
R/LH100.2020.35	20	20	125	35	38.5	25	18.05	$f_1+w/2$	32.5	65	31.6	B	05
R/LH100.2525.35	25	25	150	40	46.5	32	23.05	$f_1+w/2$	40.5	81	38.6	B	05

State R or L version

w see inserts

Dimensions in mm

Further sizes upon request

Ordering note:Wrench **P39L** is not combined with blade - separate order required!

For torque specification of the screw, please see Technical Instructions.

Spare Parts

Toolholder	Clamping Screw	TORX PLUS® Wrench	Wrench
R/LH100...15	5.17T20P	T20PQ	
R/LH100...35			P39L

Toolholder

HU100

with screwed clamping

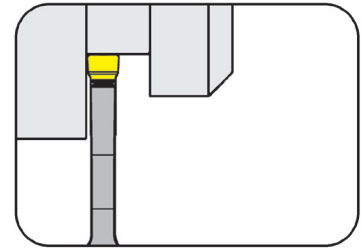

Depth of groove up to
Width of groove

1.614"
.394"

for Insert

Type S100

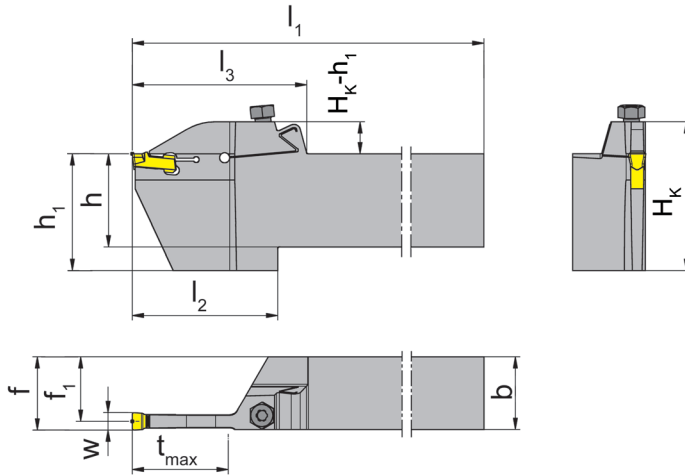

R = right hand version shown

L = left hand version

Part number	h	b	l ₁	l ₂	l ₃	h ₁	f ₁	t _{max}	H _k	Form	Size
LHU100.0750.3.04	.750	.750	6.004	1.969	2.362	1.260	.677	1.299	1.693	A	04
RHU100.0750.3.05	.750	.750	6.004	1.969	2.362	1.260	.657	1.299	1.693	A	05
LHU100.1000.3.06	1.000	1.000	6.004	1.969	2.362	1.496	.890	1.299	1.929	A	06
LHU100.1250.3.06	1.250	1.000	6.693	1.969	2.362	1.496	.890	1.299	1.929	A	06
LHU100.1250.3.8	1.250	1.000	6.693	1.969	2.362	1.496	.850	1.378	1.929	A	08
RHU100.1250.4.08	1.250	1.000	6.693	2.165	2.559	1.496	.850	1.614	1.929	A	08
RHU100.1250.4.10	1.250	1.000	6.693	2.165	2.559	1.496	.815	1.614	1.929	A	10

State R or L version

w see inserts

Dimensions in inch

Further sizes upon request

Note: $f = f_1 + w/2$

For torque specification of the screw, please see Technical Instructions.

Spare Parts

Toolholder	Clamping Screw	TORX PLUS® Wrench
R/LHU100...	030.6075.T20P	T20PQ

Toolholder

H100

with screwed clamping

Depth of groove up to
Width of groove

41 mm
4 - 12 mm

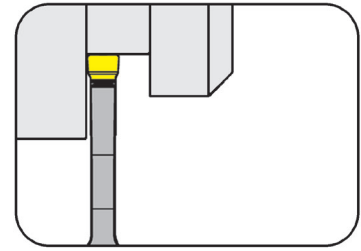

for Insert

Type S100

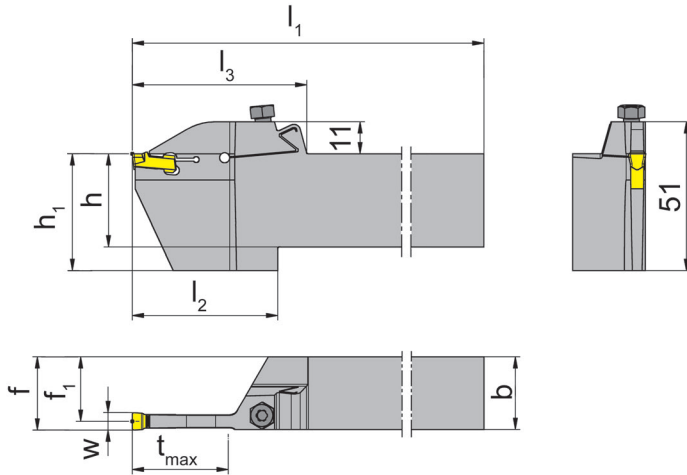

R = right hand version shown

L = left hand version

Part number	h	b	l_1	l_2	l_3	h_1	f_1	f	t_{max}	Size
R/LH100.2020.3.04	20	20	150	50	60	32	18.2	$f_1+w/2$	33	04
R/LH100.2020.3.05	20	20	150	50	60	32	17.7	$f_1+w/2$	33	05
R/LH100.2525.3.05	25	25	150	50	60	32	22.7	$f_1+w/2$	33	05
R/LH100.2525.3.06	25	25	150	50	60	40	22.2	$f_1+w/2$	33	06
R/LH100.3225.3.06	32	25	170	50	60	40	22.2	$f_1+w/2$	33	06
R/LH100.3225.3.08	32	25	170	50	60	40	21.2	$f_1+w/2$	33	08
R/LH100.3225.3.8	32	25	170	50	60	40	21.2	$f_1+w/2$	35	08
R/LH100.3225.4.08	32	25	170	55	65	40	21.2	$f_1+w/2$	41	08
R/LH100.3225.4.10	32	25	170	55	65	40	20.3	$f_1+w/2$	41	10
R/LH100.3225.4.12	32	25	170	55	65	40	19.3	$f_1+w/2$	41	12

State R or L version

w see inserts

Dimensions in mm

Further sizes upon request

For torque specification of the screw, please see Technical Instructions.

Spare Parts

Toolholder	Clamping Screw	TORX PLUS® Wrench
R/LH100...	030.6075.T20P	T20PQ

Toolholder

HU100

with screwed clamping

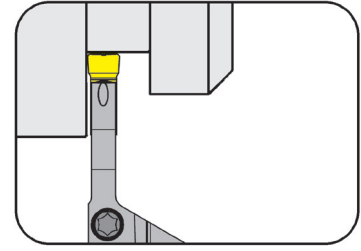

Depth of groove up to 1.299"
Width of groove .157"

for Insert

Type S100

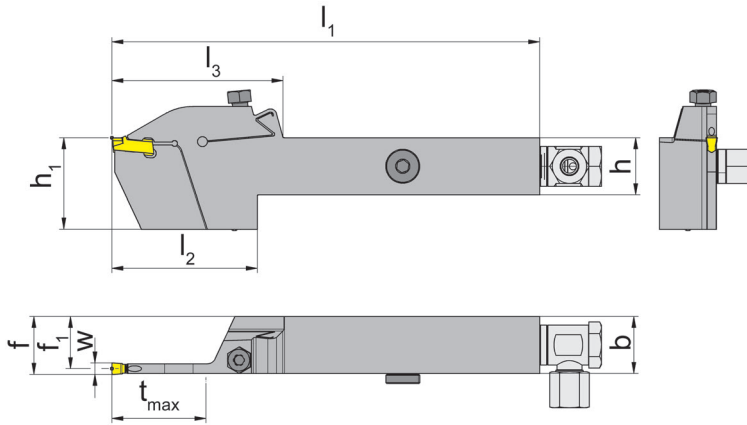

R = right hand version shown

L = left hand version

with through coolant supply

Part number	h	b	l ₁	l ₃	l ₂	h ₁	f ₁	t _{max}	D _{max}	H _K	Form	Size
R/LHU100.0750.3.0.04.IK	.750	.750	5.906	2.008	2.362	1.693	.685	1.299	5.906	1.693	A	04
R/LHU100.1000.3.0.04.IK	1.000	1.000	5.906	1.969	2.362	1.260	.933	1.299	5.906	1.693	A	04

State R or L version

w see inserts

Dimensions in inch

Further sizes upon request

Note: $f = f_1 + w/2$

For torque specification of the screw, please see Technical Instructions.

Spare Parts

Toolholder	Coolant supply	Screw	Clamping Screw	TORX PLUS® Wrench	Sealing plug
R/LHU100.0750.3.0.04.IK	004.00.61	004.00.21	030.6075.T20P	T20PQ	
R/LHU100.1000.3.0.04.IK	004.00.16		030.6075.T20P	T20PQ	004.00.26

Toolholder

HU100

with screwed clamping

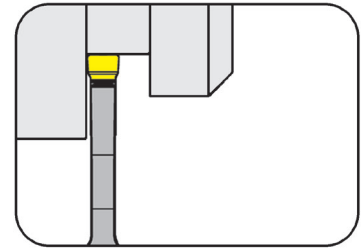

Depth of groove up to
Width of groove

1.772"
.630"

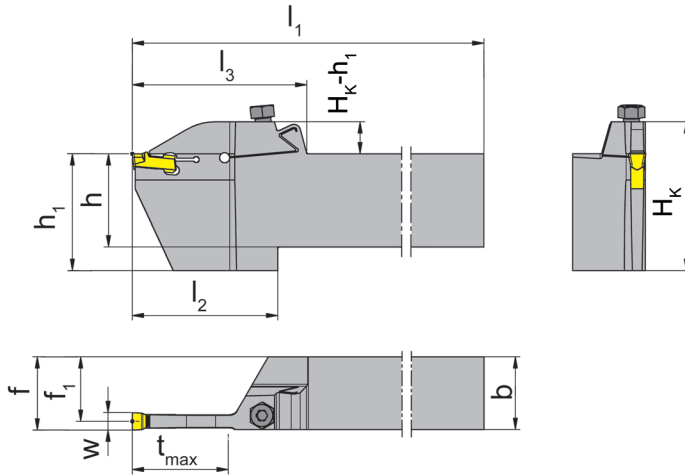

for Insert

Type S100

R = right hand version shown

L = left hand version

Part number	h	b	l ₁	l ₂	l ₃	h ₁	f ₁	f	t _{max}	H _k	Form	Size
RHU100.1250.5.16	1.250	1.250	6.693	2.165	2.205	1.850	.955	f ₁ +w/2	1.772	2.165	A	16

State R or L version

w see inserts

Dimensions in inch

Further sizes upon request

For torque specification of the screw, please see Technical Instructions.

Spare Parts

Toolholder	Clamping Screw	TORX PLUS® Wrench	Washer
RHU100.1250.5.16	030.0625.T25P	T25PQ	020.0006.3526

Toolholder

H100

with screwed clamping

Depth of groove up to
Width of groove

45 mm
16 mm

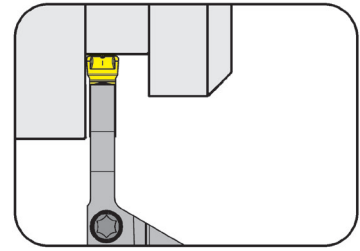

for Insert

Type S100

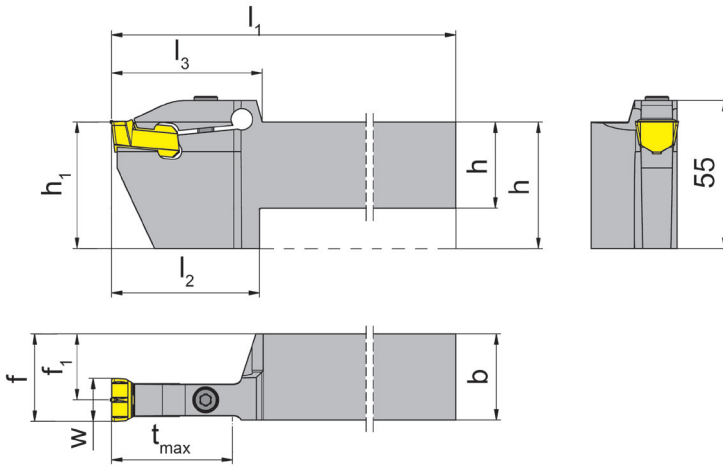

R = right hand version shown

L = left hand version

Part number	h	b	l ₁	l ₂	h ₁	f ₁	f	t _{max}	l ₃	Size
R/LH100.3232.5.16	32	32	170	55	47	24.5	f ₁ +w/2	45	56	16

State R or L version

w see inserts

Dimensions in mm

Further sizes upon request

For torque specification of the screw, please see Technical Instructions.

Spare Parts

Toolholder	Clamping Screw	TORX PLUS® Wrench	Washer
R/LH100.3232.5.16	030.0625.T25P	T25PQ	020.0006.3526

Insert

S100

with chip former

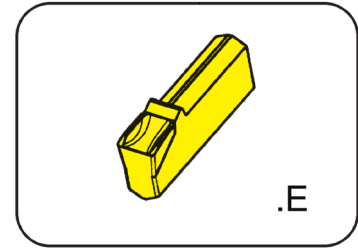

Width of groove	.079 - .197"
-----------------	--------------

for Toolholder

Type H100
HU100

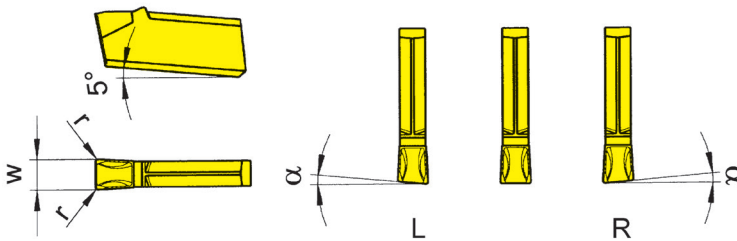

R = right hand version

L = left hand version

Part number	w	r	α	Size	ALX2	ALX3	AS63	AS66	TC92	TC93	TF42	TF43	TF45	TF46	Ti22
S100.0200.E2	.079	.008	0°	01		▲			▲	▲		▲	▲	▲	▲
R/L/S100.0520.E2	.079	.008	5°	01					x/x	x/x		▲/▲	▲/▲	▲/x	▲/▲
S100.0250.E2	.098	.008	0°	02					x	▲		▲	▲	▲	▲
R/LS100.0525.E2	.098	.008	5°	02					x/x	▲/x		▲/x	▲/x	▲/▲	x/x
S100.0300.E2	.118	.008	0°	03	▲	▲	▲	▲	▲	▲	▲	▲	▲	▲	▲
R/LS100.0530.E2	.118	.008	5°	03		▲/▲			▲/▲	▲/x	▲/x	▲/▲	▲/▲	▲/▲	▲/▲
S100.0400.E3	.157	.012	0°	04		▲			▲	▲		▲	▲	▲	▲
R/LS100.0540.E2	.157	.008	5°	04		x/x			x/x	▲/x		▲/▲	▲/▲	▲/x	▲/x
S100.0500.E3	.197	.012	0°	05				x	▲	▲		▲	▲	▲	▲
					P	•	•	•	•	•	•	•	•	•	•
					M	-	-	-	o	-	-	-	•	o	-
					K	-	-	-	•	-	-	-	•	•	-
					N	-	-	-	•	-	-	-	•	•	-
					S	-	-	-	o	-	-	-	•	o	-
					H	-	-	-	-	-	-	-	-	-	-

▲ on stock Δ 4 weeks x upon request

• recommended
o alternative recommendation
- not suitable

uncoated grades
coated grades
brazed/Cermet

Dimensions in inch

Carbide grades

State R or L version

Insert

S100

with chip former

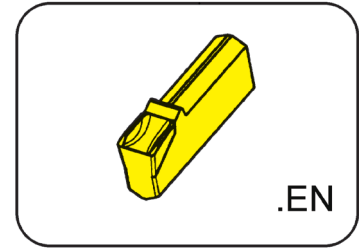

Width of groove .079 - .63"

for Toolholder

Type H100
HU100

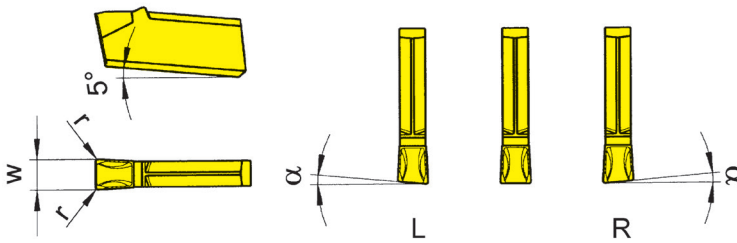

R = right hand version

L = left hand version

Part number	w	r	α	Size	ALX3	ALX5	AS62	AS63	AS66	AS6G	TF45	TH35
S100.0200.EN2	.079	.008	0°	01	▲	x				▲		x
S100.0220.EN2	.087	.008	0°	01	▲					▲		
S100.0250.EN2	.098	.008	0°	02	▲					▲		
S100.0300.EN2	.118	.008	0°	03	▲	x		▲	▲	▲	x	
RS100.0530.EN2	.118	.008	5°	03			Δ		Δ			
S100.0400.EN3	.157	.012	0°	04	▲			▲		▲		
R/LS100.0540.EN2	.157	.008	5°	04	▲/▲							
S100.0500.EN3	.197	.012	0°	05	▲							
S100.0600.EN6	.236	.031	0°	06						▲		
S100.0800.EN8	.315	.031	0°	08					▲	▲		
LS100.0480.EN8	.315	.031	4°	08					Δ			
S100.1000.EN8	.394	.031	0°	10						▲		
S100.1200.EN8	.472	.031	0°	12						▲		
S100.1600.EN8	.630	.031	0°	16						▲		
P	•	•	•	•	•	•	•	•	•	•	•	•
M	-	•	-	-	o	•	•	•	•	•	•	•
K	-	•	-	-	•	•	•	•	•	•	•	•
N	-	•	-	-	•	•	•	•	•	•	•	•
S	-	•	-	-	o	•	•	•	•	•	•	•
H	-	-	-	-	-	-	-	-	-	-	-	-

▲ on stock Δ 4 weeks x upon request
 ● recommended
 ○ alternative recommendation
 - not suitable
 ■ uncoated grades
 ■ coated grades
 ■ brazed/Cermet

Dimensions in inch

Carbide grades

State R or L version

Insert

S100

with chip former

Width of groove	.118 - .157"
-----------------	--------------

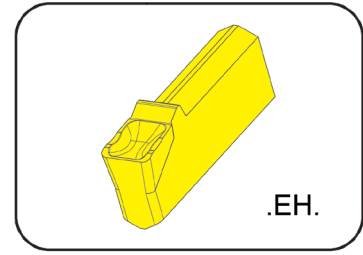

for Toolholder

Type H100
HU100
NK100

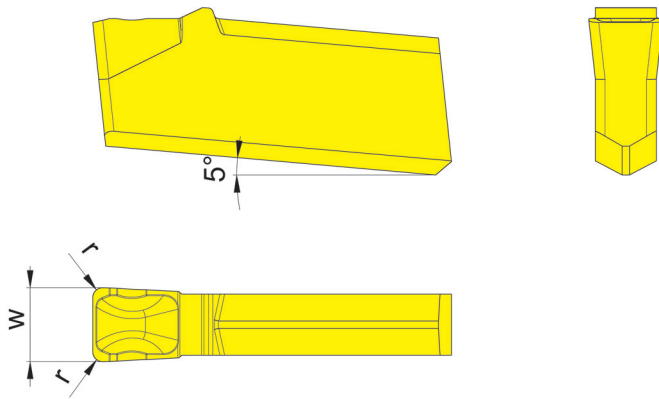

Part number	w	r	Size	IG6G
S100.0300.EH4	.118	.016	03	▲
S100.0400.EH6	.157	.024	04	▲

- ▲ on stock Δ 4 weeks x upon request
- recommended
- alternative recommendation
- not suitable
- uncoated grades
- coated grades
- brazed/Cermet

Dimensions in inch

Carbide grades

P	●
M	○
K	○
N	-
S	-
H	-

Indexable inserts can be used in right and left hand toolholders

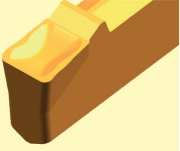
Geometry	Applications	Feed Rate	
		f (mm/rev)	f (ipr)
.EH 	Grooving and part off high feed rates	↓ 0.25 - 0.4	.0098 - .0157
		↓ Grooving	

Toolholder / Machine

High feed rates for grooving and parting off require stable machine and clamping conditions

Programming / Process

When grooving and parting off with feed rates > 0.3 mm/rev (.0118 ipr), it is recommended to reduce feedrate for the first 3-4 mm (.118-.157 in) grooving depth

Toolholder

Toolholders and cassettes for parting off in the y axis are the first choice for high feed rates

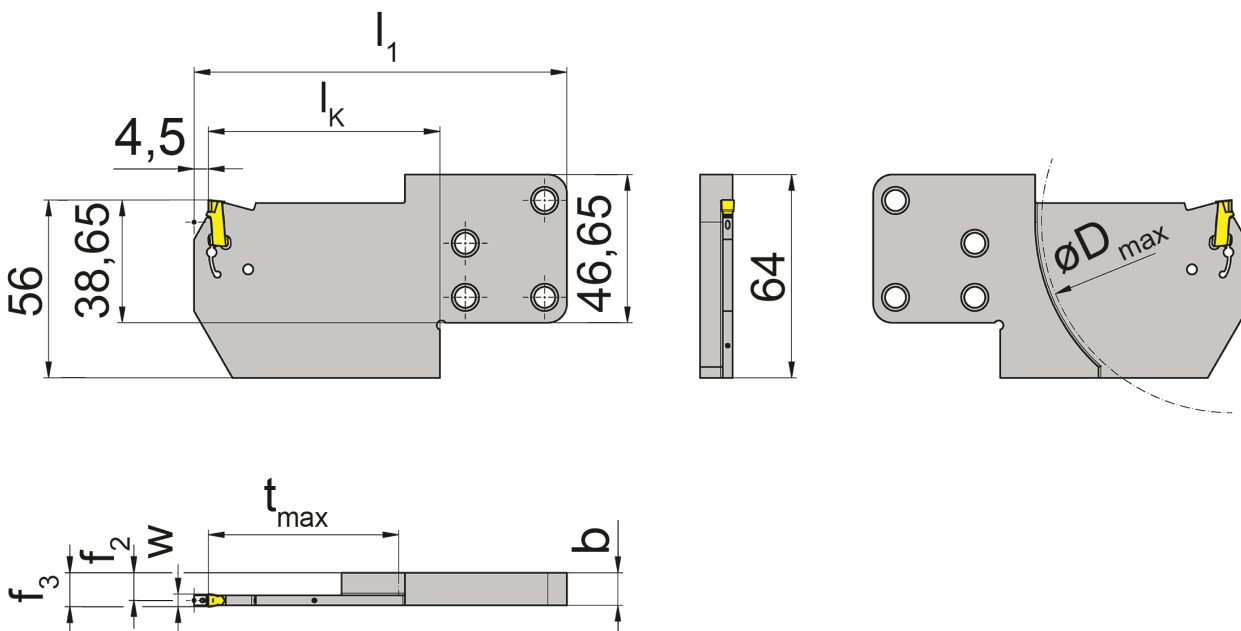

Insert

S100

with chip forming

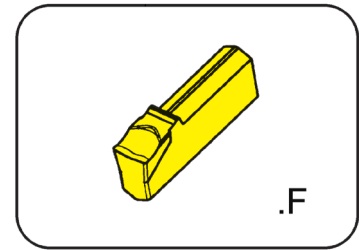

Width of groove	.079 - .197"
-----------------	--------------

for Toolholder

Type H100
HU100

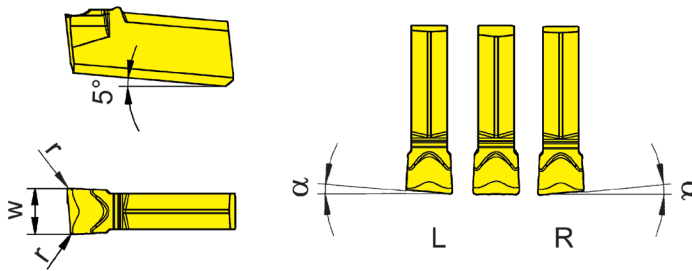

R = right hand version shown

L = left hand version

Part number	w	r	α	Size	Carbide grades						
					TC92	TC93	TF42	TF43	TF45	TF46	Ti22
S100.0200.F2	.079	.008	0°	01	▲	x		▲	▲	▲	▲
R/LS100.0520.F2	.079	.008	5°	01	x/x	x/x		x/x	▲/▲	▲/▲	x/x
S100.0250.F2	.098	.008	0°	02	x	x		▲	▲	▲	▲
R/LS100.0525.F2	.098	.008	5°	02	x/x	x/x		x/x	▲/▲	x/x	x/x
S100.0300.F2	.118	.008	0°	03	▲	▲	▲	▲	▲	▲	▲
R/LS100.0530.F2	.118	.008	5°	03	▲/x	▲/▲		▲/▲	▲/▲	▲/▲	▲/▲
S100.0400.F3	.157	.012	0°	04	x	▲		▲	▲	▲	▲
R/LS100.0540.F2	.157	.008	5°	04	x/x	x/▲		▲/▲	▲/▲	x/x	x/x
S100.0500.F3	.197	.012	0°	05	x	x		▲	▲	▲	▲
					P	●	●	●	●	●	●
					M	-	-	-	-	○	-
					K	-	-	-	-	●	-
					N	-	-	-	-	●	-
					S	-	-	-	-	○	-
					H	-	-	-	-	-	-

▲ on stock Δ 4 weeks x upon request

● recommended
○ alternative recommendation
- not suitable

uncoated grades
coated grades
brazed/Cermet

Dimensions in inch

State R or L version

Carbide grades

Insert

S100

with chip forming

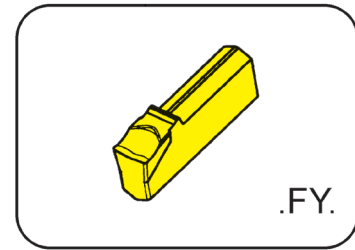

Width of groove	.079 - .157"
-----------------	--------------

precision sintered

for Toolholder

Type H100
HU100

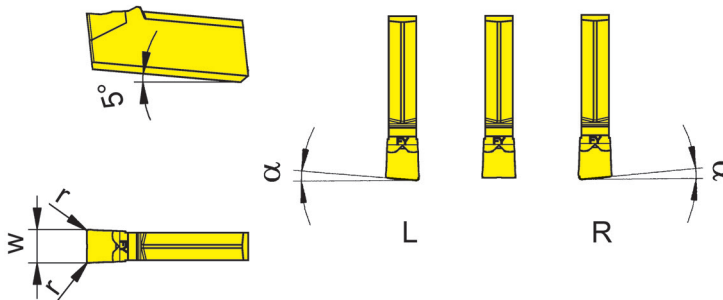

R = right hand version

L = left hand version

Part number	w	r	α	Size	AS45	HP65	IG35	PH35	TI25
S100.0200.FY2	.079	.008	0°	01	x	▲	▲	▲	▲
R/LS100.1520.FY0	.079	-	15°	01	▲/▲		▲/▲		
S100.0220.FY2	.087	.008	0°	01			▲		▲
S100.0250.FY2	.098	.008	0°	02	x	▲	▲		▲
S100.0300.FY2	.118	.008	0°	03	x	▲	▲	▲	▲
R/LS100.1530.FY0	.118	-	15°	03	▲/▲		▲/▲		
S100.0400.FY3	.157	.012	0°	04		▲	▲		▲

▲ on stock Δ 4 weeks x upon request

● recommended

○ alternative recommendation

- not suitable

□ uncoated grades

■ coated grades

■ brazed/Cermet

Dimensions in inch

	P	M	K	N	S	H
AS45	●	●	●	○	○	○
HP65	●	●	●	○	○	○
IG35	●	●	●	○	○	○
PH35	●	●	●	○	○	○
TI25	●	●	●	○	○	○

Carbide grades

Indexable inserts can be used in **right and left** hand toolholders.

Insert

S100

with chip forming

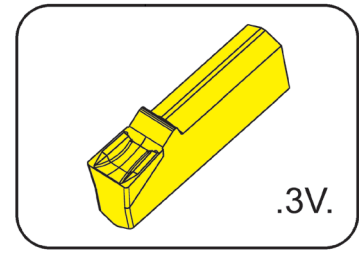

Width of groove	.079 - .157"
-----------------	--------------

for Toolholder

Type H100
HU100

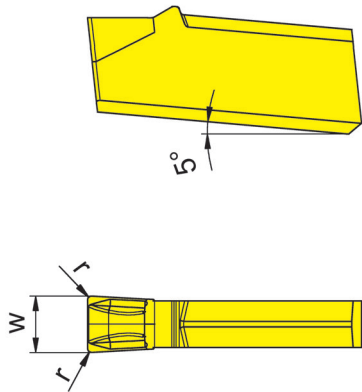

Part number	w	r	Size	Carbide grades					
				AS45	HP35	HP65	IG35	PH35	
S100.0200.3V2	.079	.008	01	▲	x	▲	▲	▲	
S100.0250.3V2	.098	.008	02	▲		▲	▲		
S100.0300.3V2	.118	.008	03	▲		▲	▲	▲	
S100.0400.3V3	.157	.012	04	▲		▲	▲		
▲ on stock Δ 4 weeks x upon request ● recommended ○ alternative recommendation - not suitable				P	●	○	●	-	○
■ uncoated grades ■ coated grades ■ brazed/Cermet				M	●	●	●	●	○
Dimensions in inch				K	●	○	●	-	●
				N	○	-	○	-	-
				S	●	○	●	●	-
				H	-	-	-	-	-

Insert

S100

with chip forming

Width of groove .079 - .118"

precision ground and polished

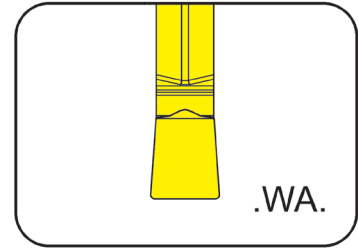

for Toolholder

Type H100
HU100

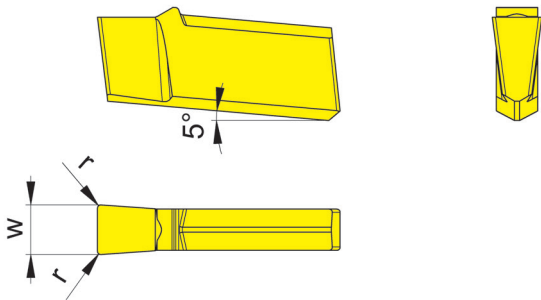

for Aluminum

Part number	w	r	Size	K10	DD26
S100.0200.WA2	.079	.008	01	▲	▲
S100.0300.WA2	.118	.008	03	▲	▲
				P ●	-
				M ○	-
				K ●	-
				N ●	●
				S ○	○
				H -	-

▲ on stock Δ 4 weeks x upon request
 ● recommended
 ○ alternative recommendation
 - not suitable
 □ uncoated grades
 ■ coated grades
 ■ brazed/Cermet
 Dimensions in inch

Carbide grades

Indexable inserts can be used in **right and left** hand toolholders.

Insert

S100

with chip forming

Width of groove .118 - .157 "

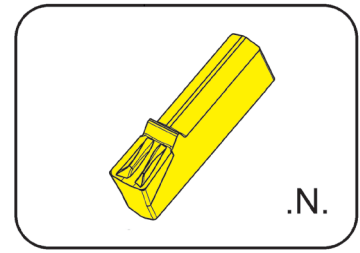

for Toolholder

Type H100
HU100

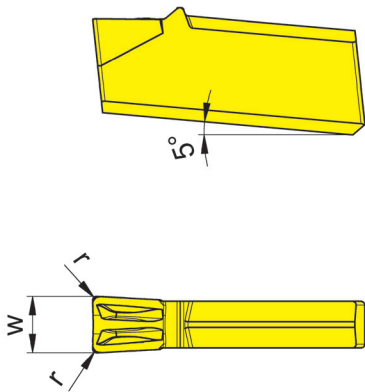

Part number	w	r	Size	Carbide grades	
				AS45	HP65
S100.0300.N2	.118	.008	03	▲	▲
S100.0400.N3	.157	.012	04	▲	▲
				P ●	●
				M ●	●
				K ●	●
				N ○	○
				S ●	●
				H -	-

▲ on stock Δ 4 weeks x upon request

- recommended
- alternative recommendation
- not suitable

- uncoated grades
- coated grades
- brazed/Cermet

Dimensions in inch

Carbide grades

Toolholder

HU100

with screwed clamping

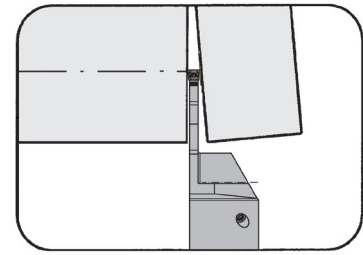

Depth of groove up to
Width of groove

1.614"
.118 - .157"

for Insert

Type S100

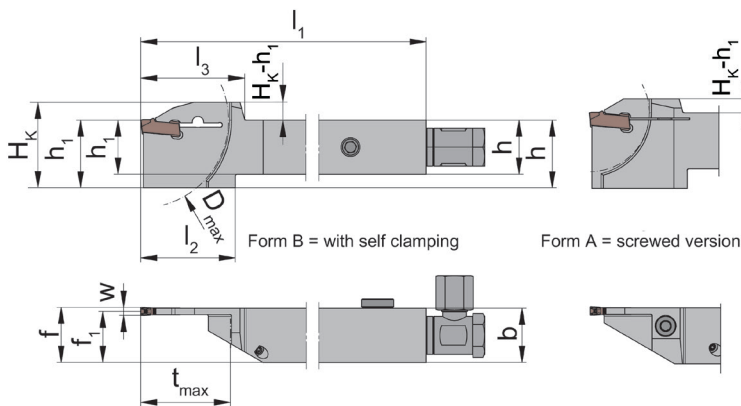

Coolant supply through insert

L = left hand version shown

R = right hand version

Part number	h	b	l ₁	l ₂	l ₃	h ₁	f ₁	f	t _{max}	D _{max}	H _K	Form	Size
R/LHU100.0625.1.23.IK	.625	.625	5.118	1.378	1.319	1.063	.580	f ₁ +w/2	.846	1.654	1.260	A	03
R/LHU100.0750.1.13.IK	.750	.750	5.118	1.181	1.122	1.063	.706	f ₁ +w/2	.630	1.654	1.260	A	03
R/LHU100.0750.1.23.IK	.750	.750	5.118	1.378	1.319	1.063	.706	f ₁ +w/2	.846	1.654	1.260	A	03
R/LHU100.0750.1.33.IK	.750	.750	5.118	1.378	1.516	1.024	.706	f ₁ +w/2	1.299	2.559	1.283	B	03
R/LHU100.1000.1.33.IK	1.000	1.000	6.004	1.378	1.516	1.260	.955	f ₁ +w/2	1.299	2.559	1.520	B	03
R/LHU100.0750.1.34.IK	.750	.750	5.118	1.378	1.516	1.024	.690	f ₁ +w/2	1.299	2.559	1.283	B	04
R/LHU100.1000.1.34.IK	1.000	1.000	6.004	1.575	1.831	1.260	.939	f ₁ +w/2	1.614	3.189	1.520	B	04

State R or L version

w see inserts

Dimensions in inch

Further sizes upon request

Ordering note:

Wrench **P39L** is not combined with blade - separate order required!

For torque specification of the screw, please see Technical Instructions.

Spare Parts

Toolholder	Clamping Screw	Threaded Pin	Coolant Supply	TORX PLUS® Wrench	Screw	Wrench
R/LHU100.0625.1.23.IK	5.17T20P	18.05.913	004.00.16	T20PQ		
R/LHU100.0750.1.13.IK	5.17T20P	18.08.913	004.00.16	T20PQ		
R/LHU100.0750.1.23.IK	5.17T20P		004.00.16	T20PQ		
R/LHU100...1.33/.34.IK			004.00.61		004.00.21	P39L

Toolholder

H100

with screwed clamping

Depth of groove up to
Width of groove

41 mm
3 - 4 mm

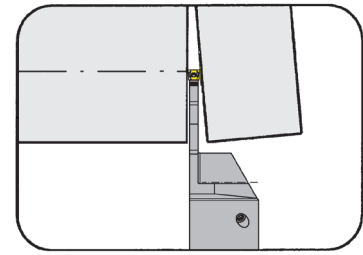

for Insert

Type S100

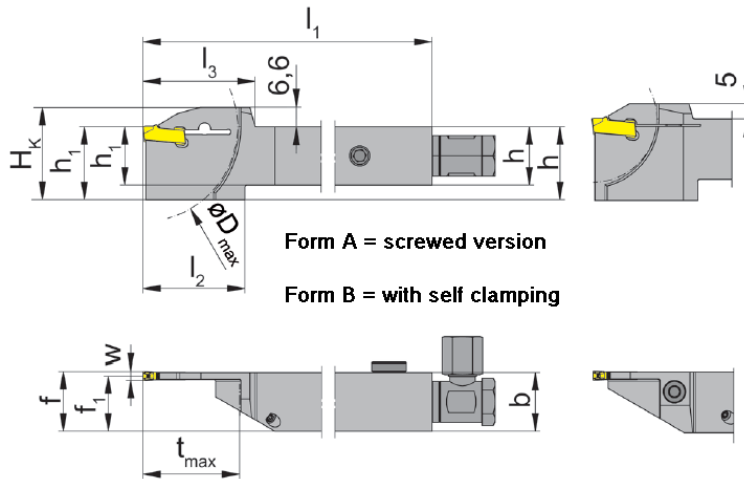

Form A = screwed version

Form B = with self clamping

Coolant supply through
insert

L = left hand version shown

R = right hand version

Part number	h	b	l ₁	l ₂	l ₃	h ₁	f ₁	f	t _{max}	D _{max}	H _K	Form	Size
R/LH100.1616.1.23.IK	16	16	125	35	33.5	27	14.85	f ₁ +w/2	21.5	42	32.0	A	03
R/LH100.2020.1.13.IK	20	20	125	30	28.5	27	18.85	f ₁ +w/2	16.0	42	32.0	A	03
R/LH100.2020.1.23.IK	20	20	125	35	33.5	27	18.85	f ₁ +w/2	21.5	42	32.0	A	03
R/LH100.2020.1.33.IK	20	20	125	35	38.5	27	18.85	f ₁ +w/2	33.0	65	33.6	B	03
R/LH100.2525.1.33.IK	25	25	150	35	38.5	32	23.85	f ₁ +w/2	33.0	65	38.6	B	03
R/LH100.2020.1.34.IK	20	20	125	35	38.5	27	18.45	f ₁ +w/2	33.0	65	33.6	B	04
R/LH100.2525.1.34.IK	25	25	150	40	46.5	32	23.45	f ₁ +w/2	41.0	81	38.6	B	04

State R or L version

w see inserts

Dimensions in mm

Further sizes upon request

Ordering note:Wrench **P39L** is not combined with blade - separate order required!

For torque specification of the screw, please see Technical Instructions.

Spare Parts

Toolholder	Clamping Screw	Sealing plug	Threaded Pin	Coolant supply	TORX PLUS® Wrench	Wrench
R/LH100...1.13/.23.IK	5.17T20P	004.00.26	18.05.913	004.00.16	T20PQ	
R/LH100...1.33/.34.IK		004.00.26	18.05.913	004.00.16		P39L

Toolholder

H100

with screwed clamping

Depth of groove up to
Width of groove

21.5 mm
2.5 mm

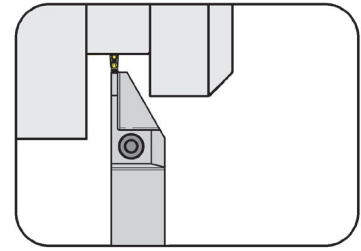

for Insert

Type S100

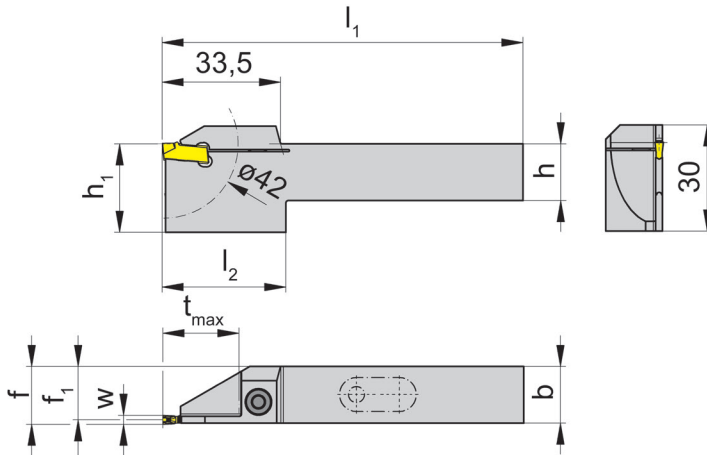

R = right hand version shown

L = left hand version

Coolant supply through insert

Part number	h	b	l ₁	l ₂	h ₁	f ₁	f	t _{max}	Size
R/LH100.1616.3.22.IK	16	16	89	35	25	15.05	f ₁ +w/2	21.5	02
R/LH100.2020.3.22.IK	20	20	102	35	25	19.05	f ₁ +w/2	21.5	02

State R or L version

w see inserts

Dimensions in mm

Further sizes upon request

For torque specification of the screw, please see Technical Instructions.

Spare Parts

Toolholder	Clamping Screw	O-ring	TORX PLUS® Wrench
R/LH100...3.22.IK	5.17T20P	12.37.2.62.3601	T20PQ

Toolholder

H100

Depth of groove up to
Width of groove

33 mm
3 mm

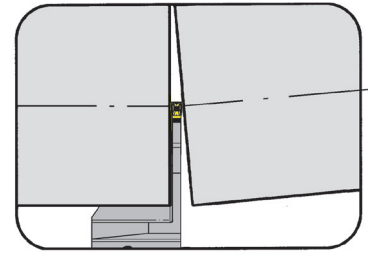

for Insert

Type S100

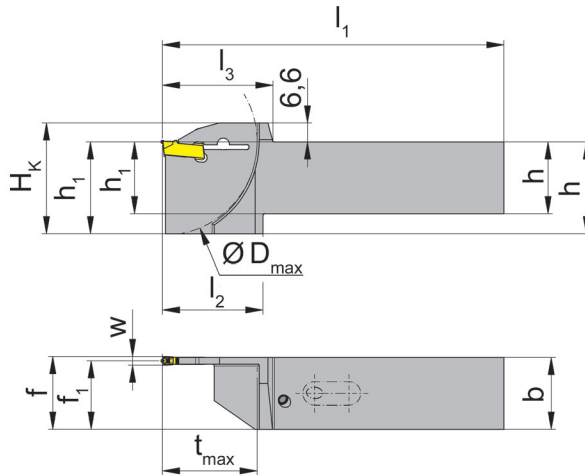

L = left hand version shown

R = right hand version

Coolant supply through
insert

Part number	h	b	l_1	l_2	l_3	h_1	f_1	f	t_{max}	D_{max}	H_k	Size
R/LH100.2020.3.33.IK	20	20	104	35	38.5	27	18.85	$f_1+w/2$	33	65	33.6	03
R/LH100.2525.3.33.IK	25	25	119	35	38.5	32	23.85	$f_1+w/2$	33	65	38.6	03

State R or L version

w see inserts

Dimensions in mm

Further sizes upon request

Ordering note:

Wrench **P39L** is not combined with blade - separate order required!

Spare Parts

Toolholder	O-ring	Wrench
R/LH100...3.33.IK	12.37.2.62.3601	P39L

Insert

S100

with chip former

Width of groove	.098 - .157"
-----------------	--------------

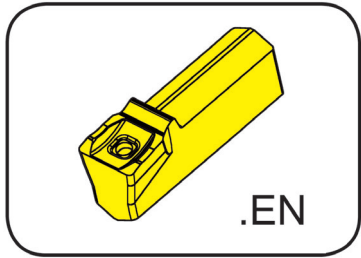

for Toolholder

Type H100
HU100

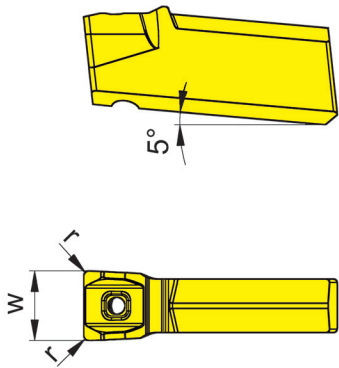

Coolant supply through insert

Part number	w	r	Size	Carbide grades		
				AS45	EG55	HP65
S100.0250.EN2.IK	.098	.008	02	▲	▲	▲
S100.0300.EN2.IK	.118	.008	03	▲	▲	▲
S100.0400.EN3.IK	.157	.012	04	▲	▲	▲
				P	•	•
				M	•	•
				K	•	•
				N	○	○
				S	•	•
				H	-	-

▲ on stock Δ 4 weeks x upon request

- recommended
- alternative recommendation
- not suitable

- uncoated grades
- coated grades
- brazed/Cermet

Dimensions in inch

Carbide grades

Indexable inserts can be used in **right and left** hand toolholders.

Insert

S100

with chip former

Width of groove	.098 - .118"
-----------------	--------------

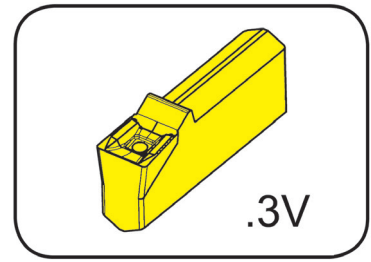

for Toolholder

Type H100
HU100

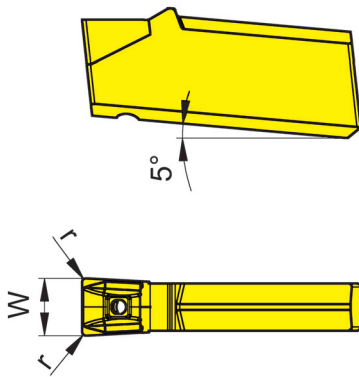

Coolant supply through insert

Part number	w	r	Size	Carbide grades	
				HP65	IG35
S100.0250.3V2.IK	.098	.008	02	▲	▲
S100.0300.3V2.IK	.118	.008	03	▲	▲
				P	•
				M	•
				K	•
				N	○
				S	•
				H	-

- ▲ on stock Δ 4 weeks x upon request
- recommended
- alternative recommendation
- not suitable
- uncoated grades
- coated grades
- brazed/Cermet

Dimensions in inch

Carbide grades

Indexable inserts can be used in **right and left** hand toolholders.

Toolholder

H101

with screwed clamping

Depth of groove up to
Width of groove

13 mm
1.2 - 1.6 mm

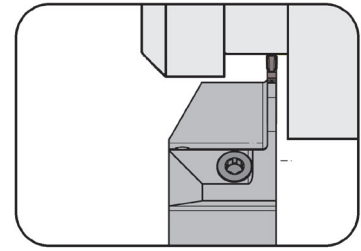

for Insert

Type S101

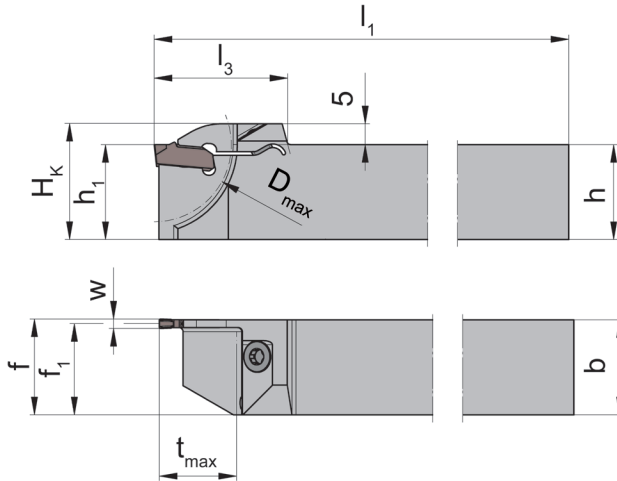

R = right hand version shown

L = left hand version

Part number	h	b	l_1	l_3	h_1	f_1	f	t_{max}	H_K	D_{max}	Size
R/LH101.1010.1.12	10	10	125	22.5	10	9.53	$f_1+w/2$	13	13.5	26	12
R/LH101.1212.1.12	12	12	125	22.5	12	11.53	$f_1+w/2$	13	15.5	26	12
R/LH101.1616.1.12	16	16	125	22.5	16	15.53	$f_1+w/2$	13	19.5	26	12
R/LH101.1010.1.16	10	10	125	22.5	10	9.35	$f_1+w/2$	13	13.5	26	16
R/LH101.1212.1.16	12	12	125	22.5	12	11.35	$f_1+w/2$	13	15.5	26	16
R/LH101.1616.1.16	16	16	125	22.5	16	15.35	$f_1+w/2$	13	19.5	26	16

State R or L version

w see inserts

Dimensions in mm

Further sizes upon request

For torque specification of the screw, please see Technical Instructions.

Spare Parts

Toolholder	Clamping Screw	TORX PLUS® Wrench
R/LH101...1.12/.16	3.5.12T10EP	T10PL

Insert

S101

with chip forming

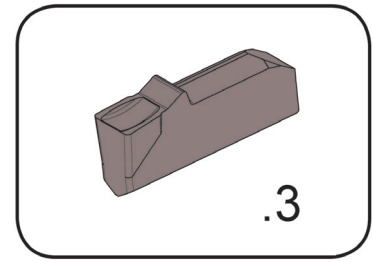

Width of groove	.047 - .063"
-----------------	--------------

for Toolholder

Type M101
H101

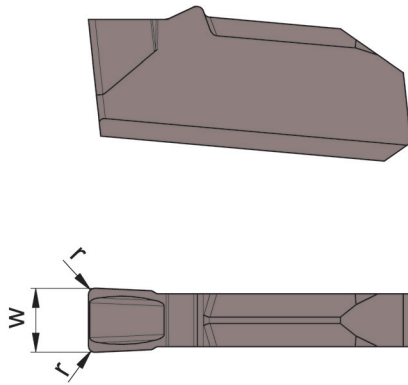

Part number	w	r	Size		
				AS45	IG35
S101.0120.315	.047	.006	12	▲	▲
S101.0160.315	.063	.006	16	▲	▲
				P	•
				M	•
				K	•
				N	○
				S	•
				H	-

▲ on stock Δ 4 weeks x upon request

- recommended
- alternative recommendation
- not suitable

- uncoated grades
- coated grades
- brazed/Cermet

Dimensions in inch

117

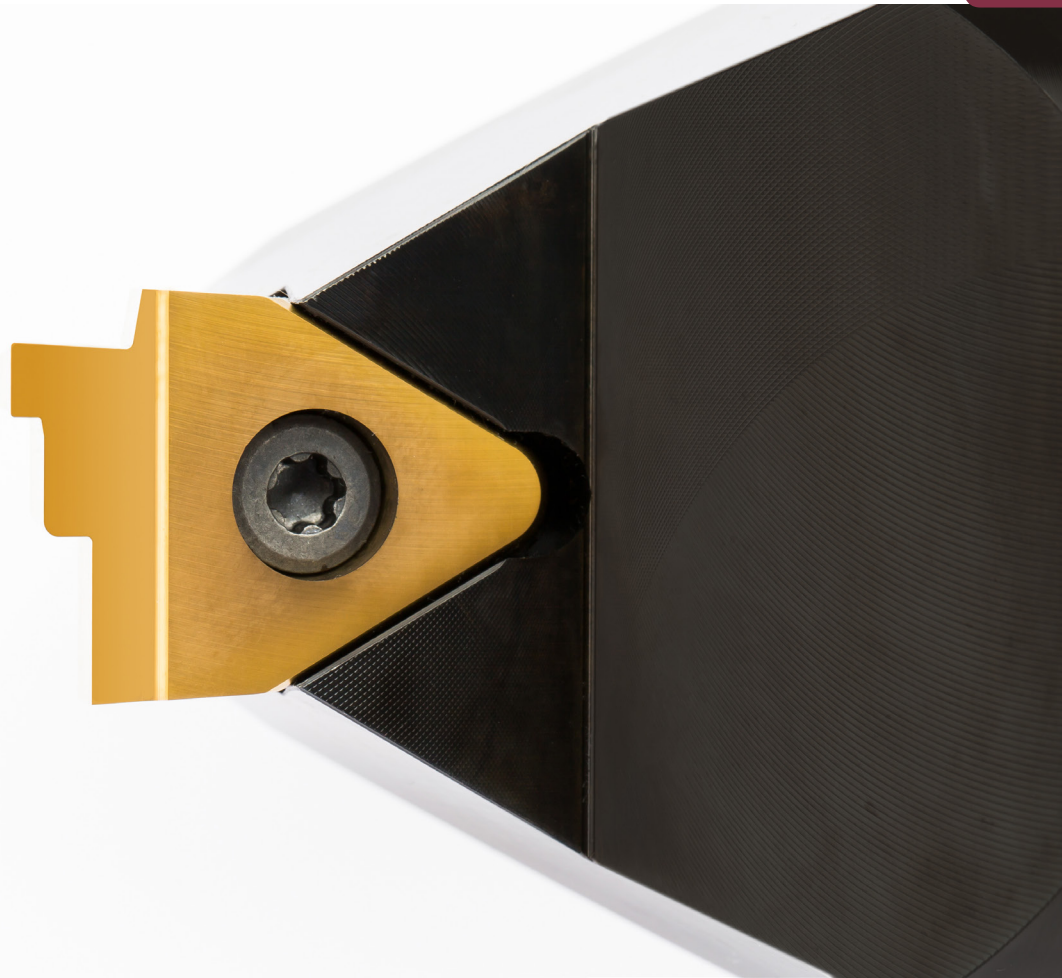

Toolholder with Inserts

Width of profile .394 - 1.772"

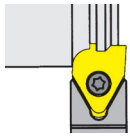

$t_{max} = \leq .394" (10 \text{ mm})$
 $w = .394 - 1.772" (10 - 45 \text{ mm})$

Toolholder
H117/HU117

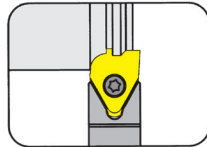

Page
B3-B6, B8

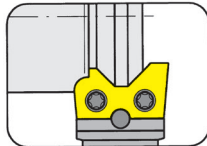

Page
B10-B11

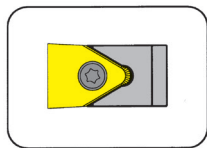

Page
B13

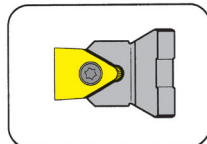

Page
B14

Insert
S117

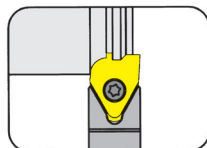

Page
B7, B9

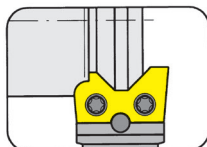

Page
B12

Toolholder

HU117

Depth of form up to .177"
Width of form up to .472"

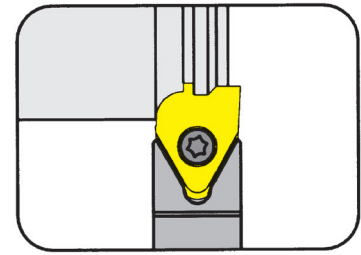

B

for Insert

Type S117

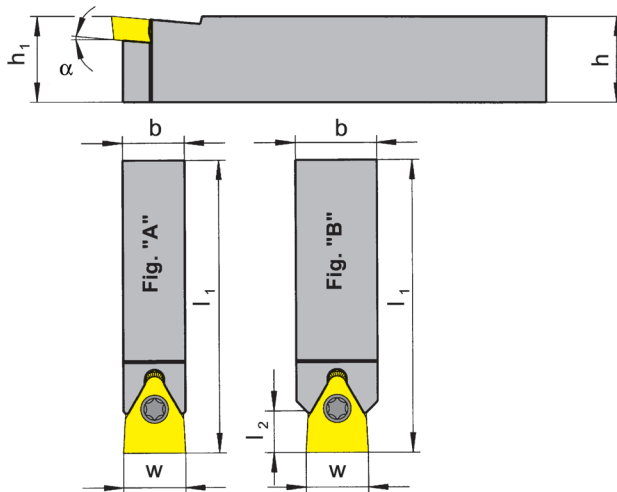

Part number	h	b	l ₁	h ₁	α	Figur	l ₂	w	Insert
HU117.0375.10	.375	.375	3.937	.375	5°	A	-	.394	S117.0010.00
HU117.0500.10	.500	.500	4.921	.500	5°	B	.303	.394	S117.0010.00
HU117.0500.12	.500	.500	4.921	.500	5°	A	.256	.472	S117.0012.00
HU117.0625.10	.625	.625	4.921	.625	5°	B	.303	.394	S117.0010.00
HU117.0625.12	.625	.625	4.921	.625	5°	B	.256	.472	S117.0012.00
HU117.0750.12	.750	.750	5.906	.750	5°	B	.256	.472	S117.0012.00

Dimensions in inch

Further angles upon request

For torque specification of the screw, please see Technical Instructions.

Spare Parts

Toolholder	Clamping Screw	TORX PLUS® Wrench
HU117.0375.10	030.400P.0227	T15PQ
HU117...12	4.09T15P	T15PQ

Toolholder

H117

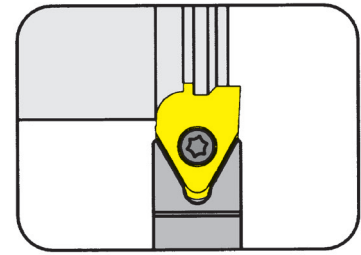

Depth of form up to 4.5 mm
Width of form up to 12 mm

for Insert

Type S117

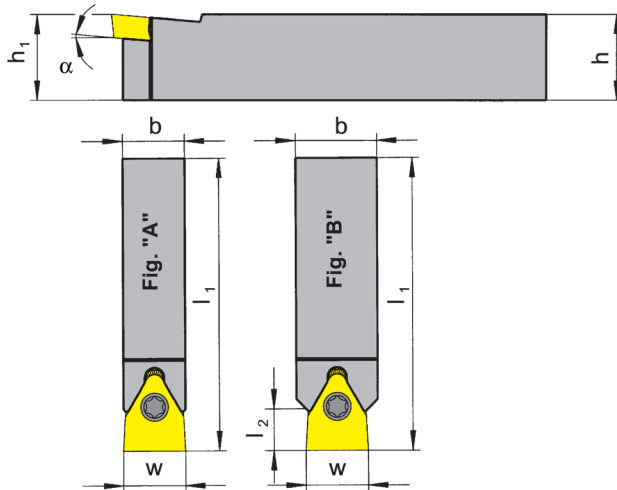

Part number	h	b	l ₁	h ₁	α	Figur	l ₂	w	Insert
H117.1010.10	10	10	100	10	5°	A	-	10	S117.0010.00
H117.1212.10	12	12	125	12	5°	B	9	10	S117.0010.00
H117.1616.10	16	16	125	16	5°	B	9	10	S117.0010.00
H117.1212.12	12	12	125	12	5°	A	-	12	S117.0012.00
H117.1414.12	14	14	125	14	5°	B	8	12	S117.0012.00
H117.1612.12	16	12	125	16	5°	A	-	12	S117.0012.00
H117.1616.12	16	16	125	16	5°	B	8	12	S117.0012.00
H117.2020.12	20	20	150	20	5°	B	8	12	S117.0012.00

Further angles upon request

Dimensions in mm

For torque specification of the screw, please see Technical Instructions.

Spare Parts

Toolholder	Clamping Screw	TORX PLUS® Wrench
H117.1010.10	030.400P.0227	T15PQ
H117...	4.09T15P	T15PQ

Toolholder

HU117

Depth of form up to .394"
Width of form up to 1.024"

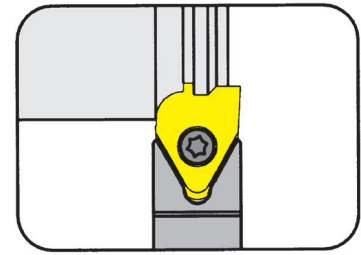

B

for Insert

Type S117

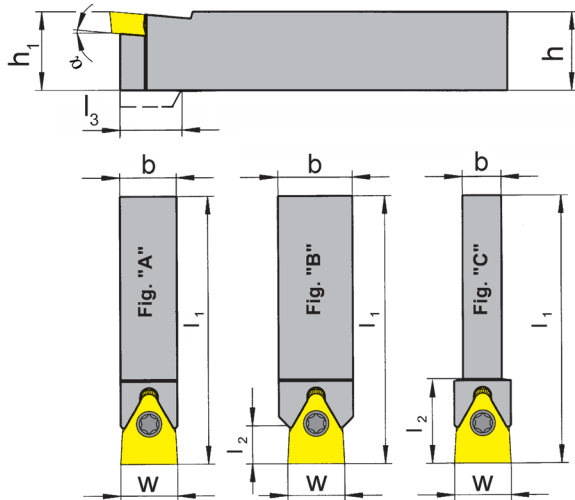

Part number	h	b	l ₁	h ₁	a	Figur	l ₂	w	Insert
HU117.0500.16	.500	.500	4.921	.500	5°	C	.335	.630/.551	S117.0014/16.00
HU117.0625.16	.625	.625	4.921	.625	5°	A / B	.335	.630/.551	S117.0014/16.00
HU117.0625.20	.625	.625	4.921	.625	5°	C	1.181	.708/.787	S117.0018/20.00
HU117.0750.16	.750	.750	5.906	.750	5°	B	.335	.630/.551	S117.0014/16.00
HU117.0750.20	.750	.750	5.906	.750	5°	A / B	.531	.708/.787	S117.0018/20.00
HU117.0750.26	.750	.750	5.906	.750	5°	C	1.181	1.024	S117.0026.00
HU117.1000.20	1.000	1.000	5.906	1.000	5°	B	.531	.708/.787	S117.0018/20.00
HU117.1000.26	1.000	1.000	5.906	1.000	5°	A	.492	1.024	S117.0026.00

Dimensions in inch

Further angles upon request

For torque specification of the screw, please see Technical Instructions.

Spare Parts

Toolholder	Clamping Screw	TORX PLUS® Wrench
HU117...16	5.12T20P	T20PQ
HU117...20/.26	6.17T20P	T20PQ

Toolholder

H117

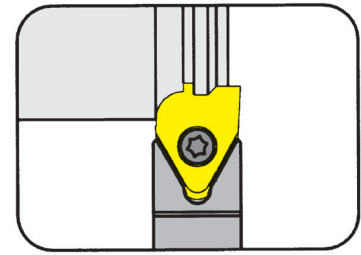

Depth of form up to 10 mm
Width of form up to 26 mm

for Insert

Type S117

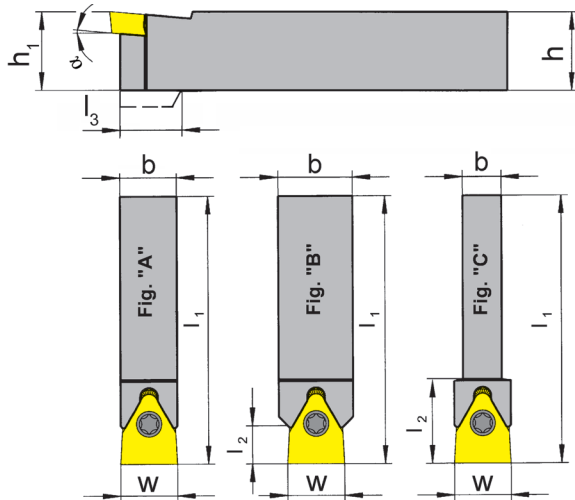

Part number	h	b	l ₁	h ₁	l ₃	a	Figur	l ₂	w	Insert
H117.1414.16	14	14	125	14	18	5°	C	22.0	14/16	S117.0014/16.00
H117.1616.16	16	16	125	16	-	5°	A / B	11.0	14/16	S117.0014/16.00
H117.2020.16	20	20	150	20	-	5°	B	11.0	14/16	S117.0014/16.00
H117.2525.16	25	25	150	25	-	5°	B	8.5	14/16	S117.0014/16.00
H117.1616.20	16	16	125	16	23	5°	C	30.0	18/20	S117.0018/20.00
H117.2020.20	20	20	150	20	-	5°	A / B	15.0	18/20	S117.0018/20.00
H117.2525.20	25	25	150	25	-	5°	B	15.0	18/20	S117.0018/20.00
H117.2020.26	20	20	150	20	-	5°	C	30.0	26	S117.0026.00
H117.2525.26	25	25	150	25	-	5°	A	-	26	S117.0026.00

Further angles upon request

Dimensions in mm

For torque specification of the screw, please see Technical Instructions.

Spare Parts

Toolholder	Clamping Screw	TORX PLUS® Wrench
H117...16	5.12T20P	T20PQ
H117...20/.26	6.17T20P	T20PQ

Insert

S117

Depth of form up to .394"
Width of form up to 1.024"

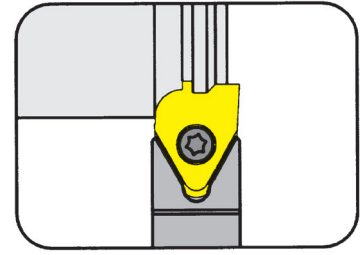

for Toolholder

Type H117

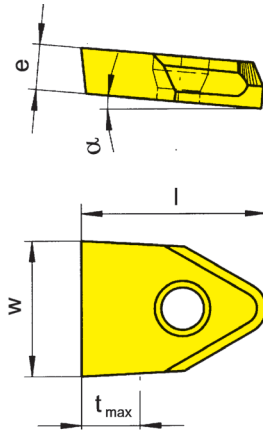

Part number	w	E	t _{max}	l	α	Toolholder	MG12	H54
S117.0010.00	.394	.118	.138	.630	5°	H117...10	▲	■
S117.0012.00	.472	.177	.177	.669	5°	H117...12	▲	▲
S117.0014.00	.551	.236	.236	.827	5°	H117...16	▲	■
S117.0016.00	.630	.236	.236	.827	5°	H117...16	▲	■
S117.0018.00	.709	.276	.354	1.142	5°	H117...20	▲	■
S117.0020.00	.787	.276	.354	1.142	5°	H117...20	▲	■
S117.0026.00	1.024	.276	.394	1.260	5°	H117...26	▲	■

▲ on stock Δ 4 weeks x upon request

● recommended

○ alternative recommendation

- not suitable

■ uncoated grades

■ coated grades

■ brazed/Cermet

P	○	●
M	-	●
K	-	-
N	-	-
S	-	-
H	-	-

Dimensions in inch

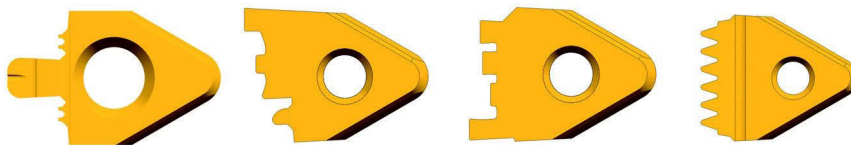

Profile inserts upon request

Toolholder

H117

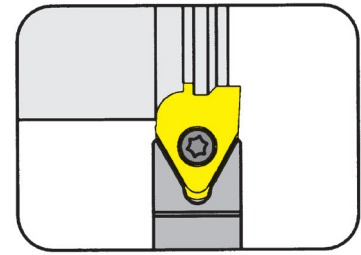

Depth of form up to
Width of form up to

13 mm
26 mm

for Insert

Type S117

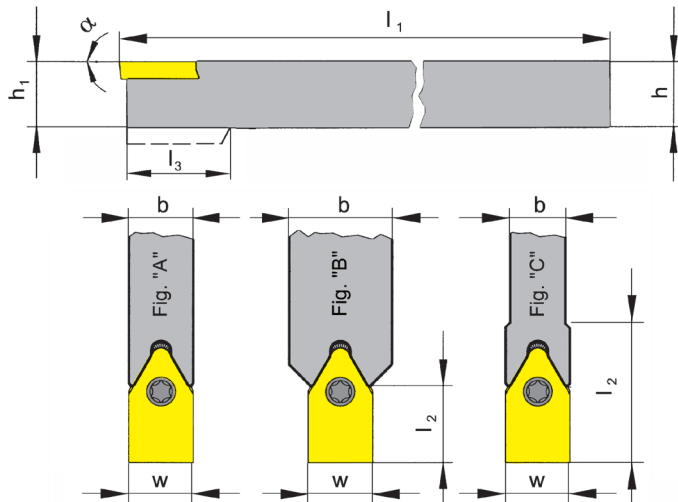

Part number	h	b	l ₁	h ₁	l ₃	α	Figur	l ₂	w	Insert
H117.1010.02.10	10	10	100	10	-	0°	A	-	10	S117.0010.02.00
H117.1212.02.10	12	12	125	12	-	0°	B	12	10	S117.0010.02.00
H117.1616.02.10	16	16	125	16	-	0°	B	12	10	S117.0010.02.00
H117.1212.02.12	12	12	125	12	-	0°	A	-	12	S117.0012.02.00
H117.1616.02.12	16	16	125	16	-	0°	B	11	12	S117.0012.02.00
H117.2020.02.12	20	20	150	20	-	0°	B	11	12	S117.0012.02.00
H117.1616.02.16	16	16	125	16	-	0°	A	-	16	S117.0016.02.00
H117.2020.02.16	20	20	150	20	-	0°	B	14	16	S117.0016.02.00
H117.1616.02.20	16	16	125	16	26	0°	C	33	20	S117.0020.02.00
H117.2020.02.20	20	20	150	20	-	0°	A	-	20	S117.0020.02.00
H117.2525.02.20	25	25	150	25	-	0°	B	19	20	S117.0020.02.00
H117.2020.02.26	20	20	150	20	-	0°	C	33	26	S117.0026.02.00
H117.2525.02.26	25	25	150	25	-	0°	A	-	26	S117.0026.02.00

Further sizes upon request

Dimensions in mm

For torque specification of the screw, please see Technical Instructions.

Spare Parts

Toolholder	Clamping Screw	TORX PLUS® Wrench
H117...10/.12	4.09T15P	T15PQ
H117...16	5.12T20P	T20PQ
H117...20/.26	6.17T20P	T20PQ

Insert

S117

Depth of form up to .512"
Width of form up to 1.024"

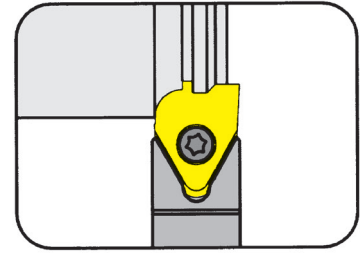

for Toolholder

Type H117

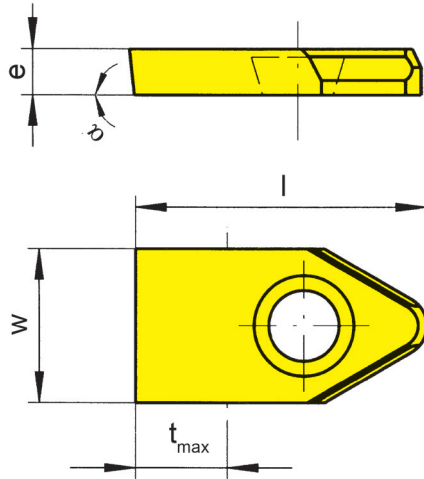

Part number	w	E	t _{max}	l	α	Toolholder	MG12
S117.0010.02.00	.394	.118	.256	.748	0°	H117...02.10	▲
S117.0012.02.00	.472	.177	.295	.787	0°	H117...02.12	▲
S117.0016.02.00	.630	.236	.354	.945	0°	H117...02.16	▲
S117.0020.02.00	.787	.276	.472	1.260	0°	H117...02.20	▲
S117.0026.02.00	1.024	.276	.512	1.378	0°	H117...02.26	▲

▲ on stock Δ 4 weeks x upon request

● recommended

○ alternative recommendation

- not suitable

□ uncoated grades

■ coated grades

■ brazed/Cermet

Further sizes upon request

P	○
M	-
K	-
N	-
S	-
H	-

Dimensions in inch



Profile inserts upon request

Toolholder

HU117

Depth of form up to
Width of form up to

.256"
1.772"

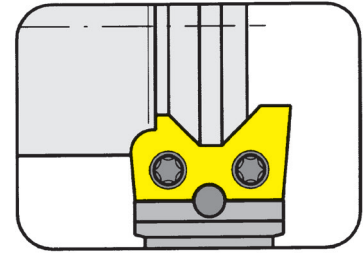

for Insert

Type S117

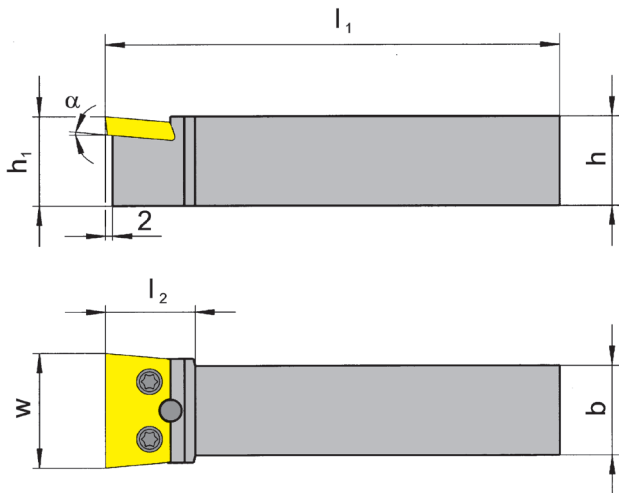

Part number	h	b	l_1	h_1	α	l_2	w	Insert
HU117.0750.32	.750	.750	5.906	.750	5°	.984	1.260	S117.0032.00
HU117.1000.32	1.000	1.000	5.906	1.000	5°	.984	1.260	S117.0032.00
HU117.1000.45	1.000	1.000	5.906	1.000	5°	1.063	1.772	S117.0045.00
HU117.1250.45	1.250	1.250	6.693	1.250	5°	1.063	1.772	S117.0045.00

Dimensions in inch

Further angles upon request

For torque specification of the screw, please see Technical Instructions.

Spare Parts

Toolholder	Clamping Screw	TORX PLUS® Wrench
HU117...	5.12T20P	T20PQ

Toolholder

H117

Depth of form up to 6.5 mm
Width of form up to 45 mm

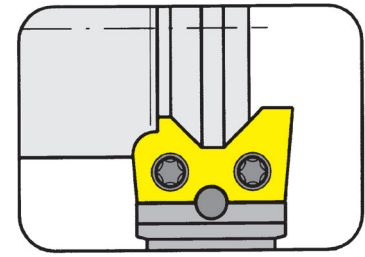

B

for Insert

Type S117

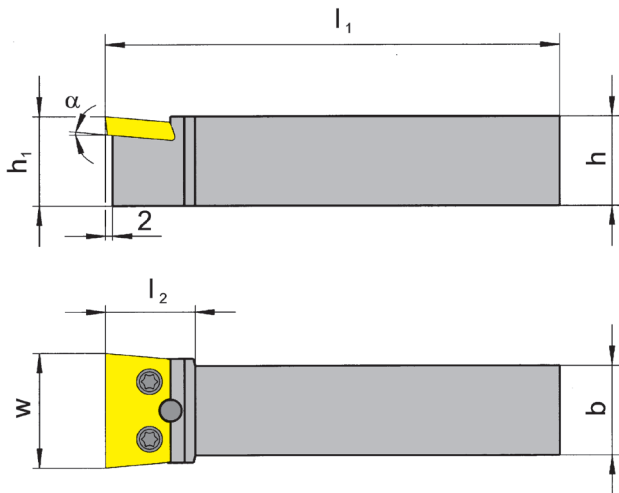

Part number	h	b	l_1	h_1	α	l_2	w	Insert
H117.2020.32	20	20	150	20	5°	25	32	S117.0032.00
H117.2525.32	25	25	150	25	5°	25	32	S117.0032.00
H117.2525.45	25	25	150	25	5°	27	45	S117.0045.00
H117.3232.45	32	32	170	32	5°	27	45	S117.0045.00

Further angles upon request

Dimensions in mm

For torque specification of the screw, please see Technical Instructions.

Spare Parts

Toolholder	Clamping Screw	TORX PLUS® Wrench	Straight pin
H117...	5.12T20P	T20PQ	5M6.12.6325

B

Insert

S117

Depth of form up to
Width of form up to

.256"
1.772"

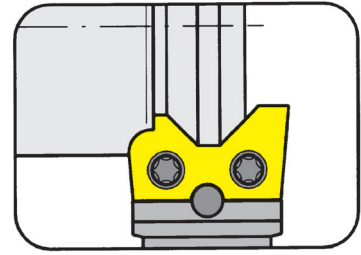

for Toolholder

Type H117

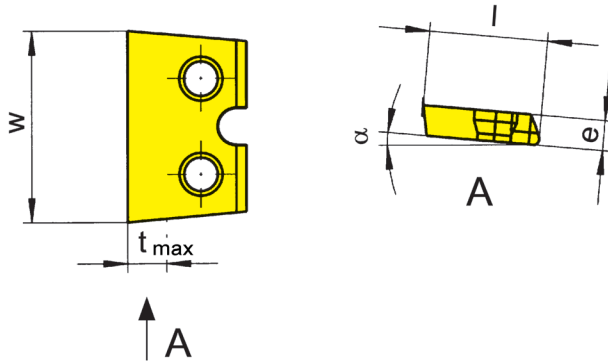

Part number	w	E	t _{max}	l	α	Toolholder	MG12
S117.0032.00	1.260	.197	.256	.776	5°	H117...32	▲
S117.0045.00	1.772	.197	.256	.776	5°	H117...45	▲

▲ on stock Δ 4 weeks x upon request

- recommended
- alternative recommendation
- not suitable

- uncoated grades
- coated grades
- brazed/Cermet

Further sizes upon request

P	○
M	-
K	-
N	-
S	-
H	-

Dimensions in inch

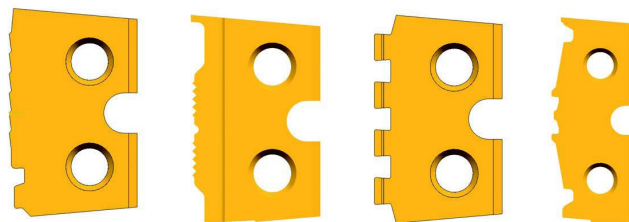

Profile inserts upon request

Toolholder

H117

Depth of form up to 6.5 mm
Width of form up to 45 mm

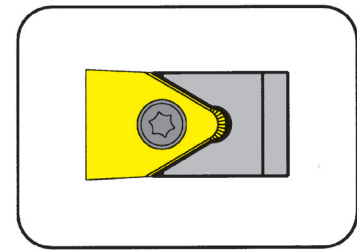

B

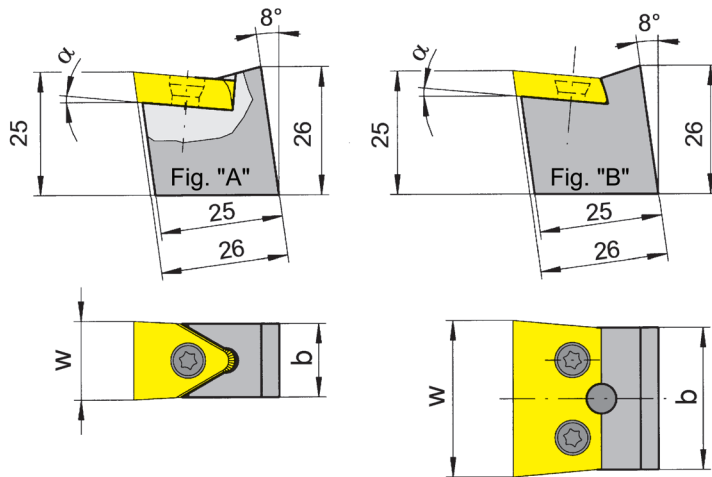

for Insert

Type S117

with PWP-System

Part number	b	a	Figur	w	Insert
H117.PWP.10	10	5°	A	10	S117.0010.00
H117.PWP.12	12	5°	A	12	S117.0012.00
H117.PWP.16	16	5°	A	14/16	S117.0014/16.00
H117.PWP.32	28	5°	B	32	S117.0032.00
H117.PWP.45	42	5°	B	45	S117.0045.00

Further angles upon request

Dimensions in mm

For torque specification of the screw, please see Technical Instructions.

Spare Parts

Toolholder	Clamping Screw	TORX PLUS® Wrench
H117.PWP.10	4.09T15P	T15PL
H117.PWP.12	4.09T15P	T15PQ
H117.PWP...	5.12T20P	T20PQ

Toolholder

H117

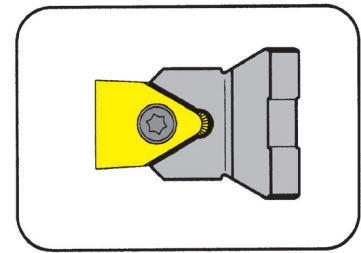

Depth of form up to
Width of form up to

10 mm
45 mm

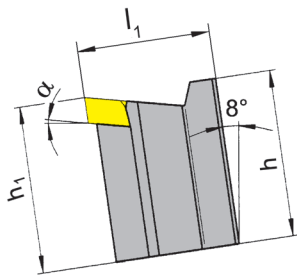

Fig. "A"

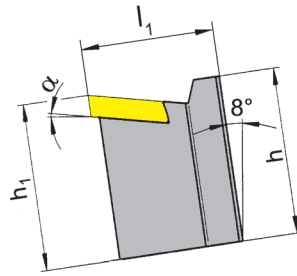
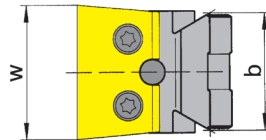
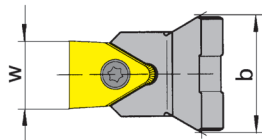

Fig. "B"



for Insert

Type S117

with AWN-System

Part number	h	b	l ₁	h ₁	t _{max}	α	Figur	w	Insert
H117.AW20.10	36	20	32	40	3.5	5°	A	10	S117.0010.00
H117.AW28.10	36	28	32	40	3.5	5°	A	10	S117.0010.00
H117.AW20.12	36	20	32	40	4.5	5°	A	12	S117.0012.00
H117.AW28.12	36	28	32	40	4.5	5°	A	12	S117.0012.00
H117.AW20.16	36	20	32	40	6.5	5°	A	14/16	S117.0014/16.00
H117.AW28.16	36	28	32	40	6.5	5°	A	14/16	S117.0014/16.00
H117.AW28.20	36	28	32	40	9.0	5°	A	18/20	S117.0018/20.00
H117.AW28.26	36	28	35	40	10.0	5°	A	26	S117.0026.00
H117.AW28.32	36	28	32	40	6.5	5°	B	32	S117.0032.00
H117.AW40.45	50	40	32	50	6.5	5°	B	45	S117.0045.00

Further angles upon request

Dimensions in mm

For torque specification of the screw, please see Technical Instructions.

Spare Parts

Toolholder	Clamping Screw	TORX PLUS® Wrench
H117.AW...10/.12	4.09T15P	T15PQ
H117.AW...16/.32/.45	5.12T20P	T20PQ
H117.AW28...20/.26	6.17T20P	T20PQ

119/123/223

C



Toolholder with Inserts

Width of groove .043 - .118"

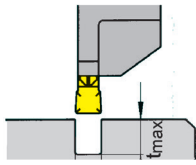

$w = .043 - .118'' (1.1 - 3 \text{ mm})$
 $t_{\text{max}} = .394'' (10 \text{ mm})$

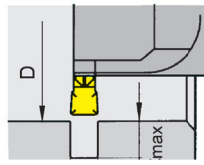

$w = .043 - .118'' (1.1 - 3 \text{ mm})$
 $t_{\text{max}} = .248'' (6.3 \text{ mm})$
 $D \geq .630'' (16 \text{ mm})$

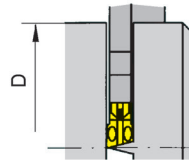

$w = .078 - .118'' (2 - 3 \text{ mm})$
 $D_{\text{max}} \leq 1.969'' (50 \text{ mm})$

Toolholder
HU223/H223

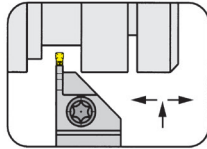

Page
C3-C4, C27

Insert
S119/S123

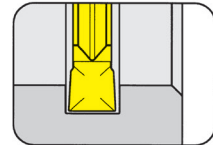

Page
C18

Cartridge
E223

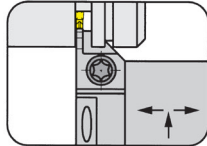

Page
C5

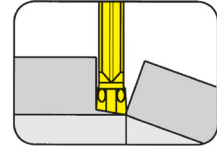

Page
C19-C20

Toolholder
BU119/B119

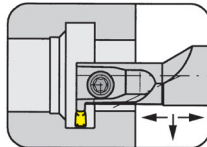

Page
C6-C7

Indexable Insert
S223

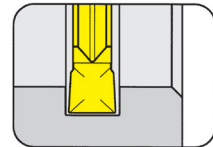

Page
C21, C23-C24

Toolholder
BU223/B223

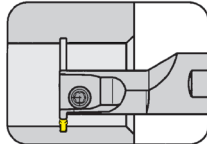

Page
C8-C12

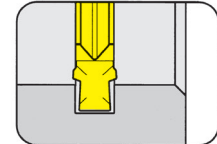

Page
C22

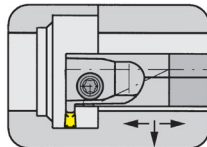

Page
C13-C14

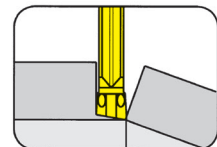

Page
C25-C26

Basic Toolholder
B223

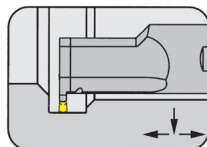

Page
C15-C16

Cassette
BK223

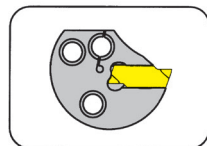

Page
C17

Grooving and Side Turning (external)



Toolholder

HU223

Depth of groove up to
Clamping range

.394"
.079 - .118"

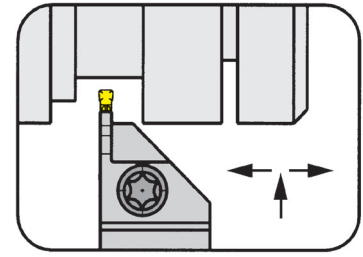

for Insert

Type S123
S223

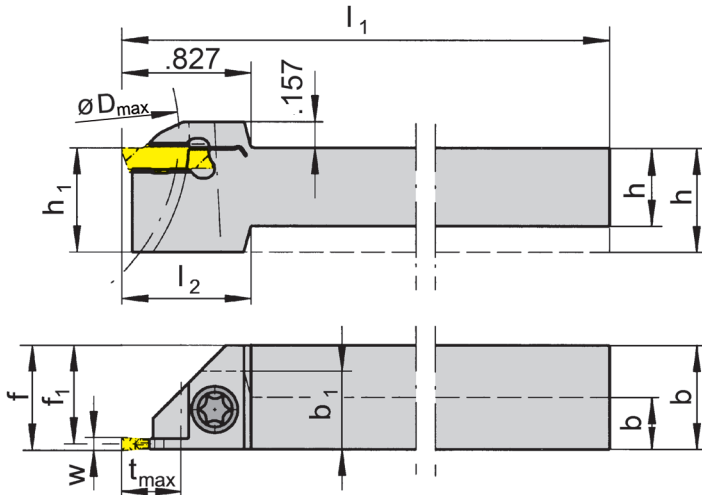

R = right hand version shown

L = left hand version

Part number	h	b	l ₁	l ₂	h ₁	b ₁	f	t _{max}	D _{max}	Size	Clamping range
R/LHU223.0375.01	.375	.375	3.150	.787	.472	.453	f ₁ +w/2	.315	.984	01	.079
R/LHU223.0500.01	.500	.500	3.996	.827	.500	-	f ₁ +w/2	.394	1.969	01	.079
R/LHU223.0625.01	.625	.625	5.118	.827	.625	-	f ₁ +w/2	.394	1.969	01	.079
R/LHU223.0750.01	.750	.750	5.118	.827	.750	-	f ₁ +w/2	.394	1.969	01	.079
R/LHU223.1000.01	1.000	1.000	6.004	.827	1.000	-	f ₁ +w/2	.394	1.969	01	.079
R/LHU223.0375.02	.375	.375	3.150	.787	.472	.453	f ₁ +w/2	.315	.984	02	.098
R/LHU223.0500.02	.500	.500	3.996	-	.500	-	f ₁ +w/2	.394	1.969	02	.098
R/LHU223.0625.02	.625	.625	5.118	-	.625	-	f ₁ +w/2	.394	1.969	02	.098
R/LHU223.0750.02	.750	.750	5.118	.827	.750	-	f ₁ +w/2	.394	1.969	02	.098
R/LHU223.1000.02	1.000	1.000	6.004	.827	1.000	-	f ₁ +w/2	.394	1.969	02	.098
R/LHU223.0500.03	.500	.500	3.996	.827	.500	-	f ₁ +w/2	.394	1.969	03	.118
R/LHU223.0625.03	.625	.625	5.118	.827	.625	-	f ₁ +w/2	.394	1.969	03	.118
R/LHU223.0750.03	.750	.750	5.118	.827	.750	-	f ₁ +w/2	.394	1.969	03	.118
R/LHU223.1000.03	1.000	1.000	6.004	-	1.000	-	f ₁ +w/2	.394	1.969	03	.118

State R or L version

w see indexable inserts

Dimensions in inch

Further sizes upon request

For torque specification of the screw, please see Technical Instructions.

Spare Parts

Toolholder	Clamping Screw	TORX PLUS® Wrench
R/LHU223...	5.11T15P	T15PL

Toolholder

H223

Depth of groove up to
Clamping range

10 mm
2 - 3 mm

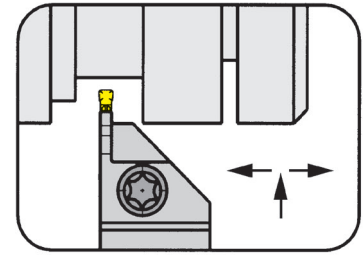

for Insert

Type S123
S223

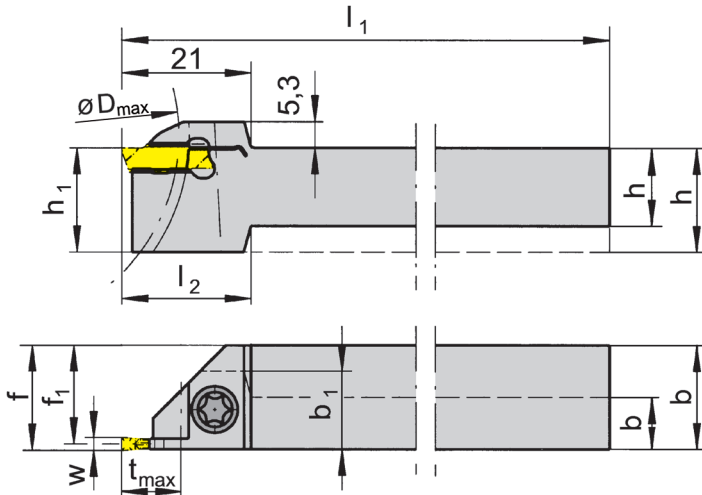

R = right hand version shown

L = left hand version

Part number	h	b	l ₁	l ₂	h ₁	b ₁	f ₁	f	t _{max}	D _{max}	Size	Clamping range
R/LH223.1010.01	10	10	80	20	12	12	9.20	f ₁ +w/2	8	25	01	2.0
R/LH223.1212.01	12	12	100	21	16	-	11.20	f ₁ +w/2	10	50	01	2.0
R/LH223.1616.01	16	16	125	-	16	-	15.20	f ₁ +w/2	10	50	01	2.0
R/LH223.2020.01	20	20	125	-	20	-	19.20	f ₁ +w/2	10	50	01	2.0
R/LH223.2525.01	25	25	150	-	25	-	24.20	f ₁ +w/2	10	50	01	2.0
R/LH223.1010.02	10	10	80	20	12	12	9.05	f ₁ +w/2	8	25	02	2.5
R/LH223.1212.02	12	12	100	21	16	-	11.05	f ₁ +w/2	10	50	02	2.5
R/LH223.1616.02	16	16	125	-	16	-	15.05	f ₁ +w/2	10	50	02	2.5
R/LH223.2020.02	20	20	125	-	20	-	19.05	f ₁ +w/2	10	50	02	2.5
R/LH223.2525.02	25	25	150	-	25	-	24.05	f ₁ +w/2	10	50	02	2.5
R/LH223.1010.03	10	10	80	20	12	12	8.80	f ₁ +w/2	8	25	03	3.0
R/LH223.1212.03	12	12	100	21	16	-	10.80	f ₁ +w/2	10	50	03	3.0
R/LH223.1616.03	16	16	125	-	16	-	14.80	f ₁ +w/2	10	50	03	3.0
R/LH223.2020.03	20	20	125	-	20	-	18.80	f ₁ +w/2	10	50	03	3.0
R/LH223.2525.03	25	25	150	-	25	-	23.80	f ₁ +w/2	10	50	03	3.0

State R or L version

w see indexable inserts

Dimensions in mm

Further sizes upon request

For torque specification of the screw, please see Technical Instructions.

Spare Parts

Toolholder	Clamping Screw	TORX PLUS® Wrench
R/LH223...	5.11T15P	T15PL

Grooving and Side Turning (external)



Cartridge

E223

Depth of groove up to 10 mm
Clamping range 2 - 3 mm

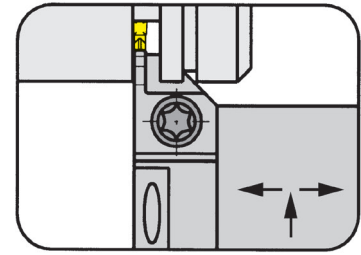

for Insert

Type S123
S223

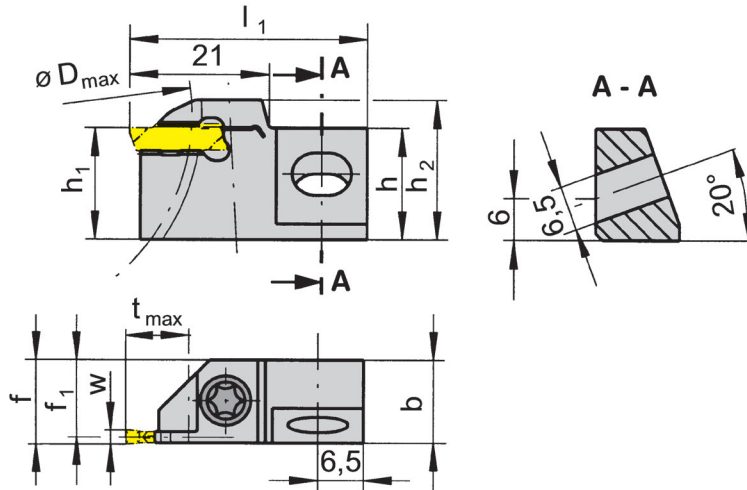

R = right hand version shown

L = left hand version

Part number	h	b	l ₁	h ₁	f ₁	f	t _{max}	D _{max}	h ₂	Size	Clamping range
R/LE223.1212.01	16	12	34	12	11.20	f ₁ +w/2	10	50	17.3	01	2.0 - 2.0
R/LE223.1616.01	16	12	34	16	11.20	f ₁ +w/2	10	50	21.3	01	2.0 - 2.0
R/LE223.1212.02	16	12	34	12	11.05	f ₁ +w/2	10	50	17.3	02	2.5 - 2.5
R/LE223.1616.02	16	12	34	16	11.05	f ₁ +w/2	10	50	21.3	02	2.5 - 2.5
R/LE223.1212.03	16	12	34	12	10.80	f ₁ +w/2	10	50	17.3	03	3.0 - 3.0
R/LE223.1616.03	16	12	34	16	10.80	f ₁ +w/2	10	50	21.3	03	3.0 - 3.0

State R or L version

w see indexable inserts

Dimensions in mm

Further sizes upon request

For torque specification of the screw, please see Technical Instructions.

Spare Parts

Cartridge	Clamping Screw	Screw	TORX PLUS® Wrench
R/LE223...	5.11T15P	6.20.232	T15PL

Toolholder

BU119

Bore \varnothing from .625"
 Depth of groove up to .118"
 Clamping range up to .118"

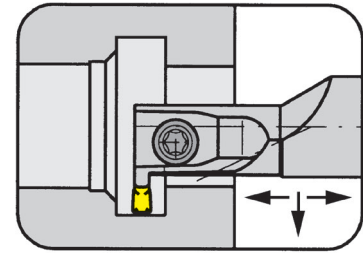

for Insert

Type S119

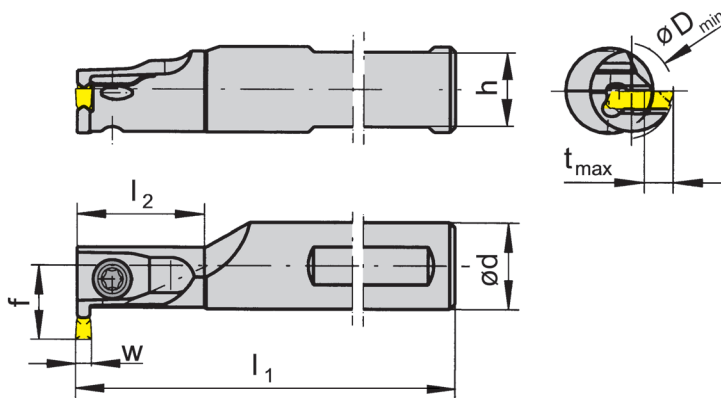

R = right hand version shown

L = left hand version

Part number	d	l ₁	l ₂	h	f	t _{max}	D _{min}	Size	Clamping range
RBU119.0625.1.32	.625	4.331	.984	.546	.465	.118	.625	02	.079-.118
RBU119.0625.1.33	.625	4.331	.984	.546	.465	.118	.625	03	.118-.118

State R or L version

w see inserts

Dimensions in inch

Further angles upon request

For torque specification of the screw, please see Technical Instructions.

Spare Parts

Toolholder	Clamping Screw	TORX PLUS® Wrench
RBU119...	5.11T15P	T15PQ

Grooving and Side Turning (internal)



Toolholder

B119

with through coolant supply

Bore \varnothing from
Depth of groove up to
Clamping range

16 mm
3 mm
2 - 3 mm

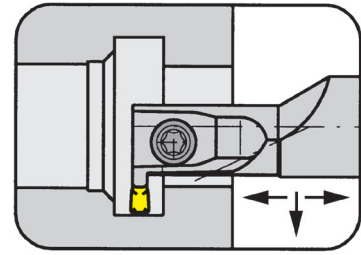

for Insert

Type S119

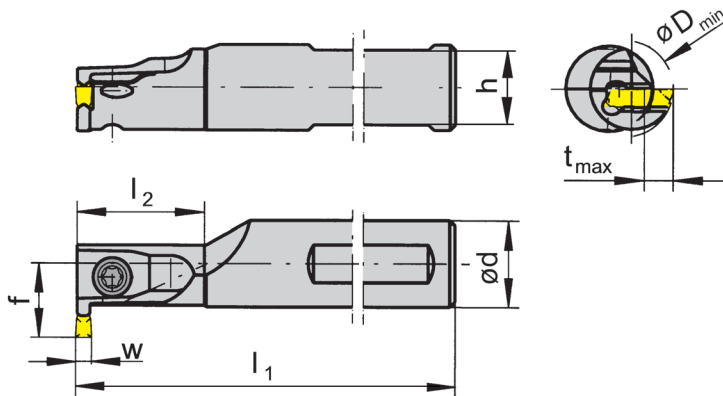

R = right hand version shown

L = left hand version

Part number	d	l ₁	l ₂	h	f	t _{max}	D _{min}	Size	Clamping range
R/LB119.0016.1.32	16	110	25	14	11.8	3	16	02	2.00 - 2.99
R/LB119.0016.1.33	16	110	25	14	11.8	3	16	03	3.00 - 3.00

State R or L version

w see inserts

Dimensions in mm

Further sizes upon request

For torque specification of the screw, please see Technical Instructions.

Spare Parts

Toolholder	Clamping Screw	TORX PLUS® Wrench
R/LB119...	5.11T15P	T15PL

Grooving and Side Turning (internal)



Toolholder

B223

with through coolant supply

Bore \varnothing from
Depth of groove up to
Clamping range

22 mm
6.3 mm
2 - 3 mm

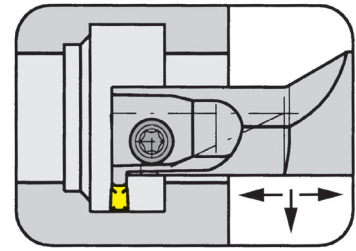

for Indexable insert

Type S223
S123

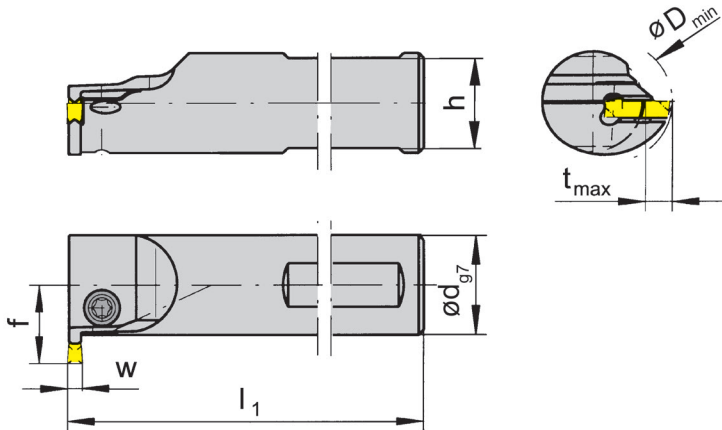

R = right hand version shown

L = left hand version

Part number	d	l ₁	h	f	t _{max}	D _{min}	Size	Clamping range
R/LB223.0016.0.42	16	110	14	13.0	4.5	22	02	2.00 - 2.99
R/LB223.0020.0.52	20	120	18	15.7	5.3	27	02	2.00 - 2.99
R/LB223.0025.0.62	25	150	23	19.3	6.3	33	02	2.00 - 2.99
R/LB223.0016.0.43	16	110	14	13.0	4.5	22	03	3.00 - 3.00
R/LB223.0020.0.53	20	120	18	15.7	5.3	27	03	3.00 - 3.00
R/LB223.0025.0.63	25	150	23	19.3	6.3	33	03	3.00 - 3.00

State R or L version

w see indexable inserts

Dimensions in mm

Further sizes upon request

For torque specification of the screw, please see Technical Instructions.

Spare Parts

Toolholder	Clamping Screw	TORX PLUS® Wrench
R/LB223...	5.11T15P	T15PL

Grooving (internal)



Toolholder

BU223

with through coolant supply

Bore \varnothing from
Circlip grooves

.709"
DIN471/472

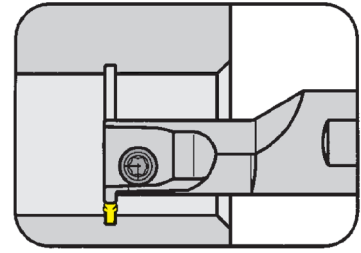

for Indexable insert

Type S223

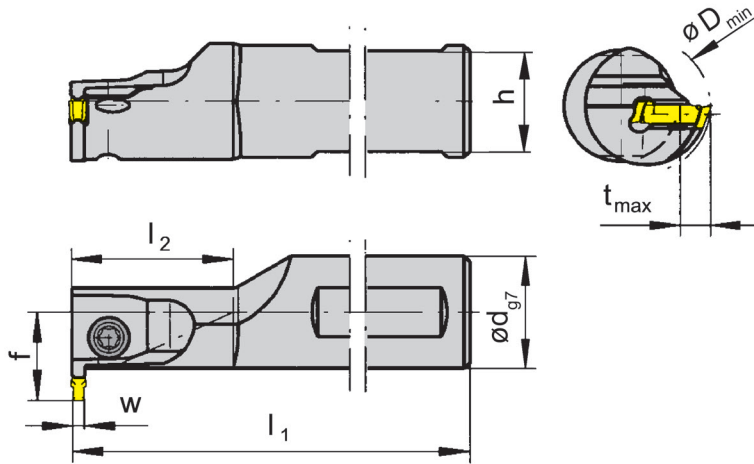

R = right hand version shown

L = left hand version

Part number	l_1	t_{max}	l_2	D_{min}	Size	Clamping range
R/LBU223.0625.1.22	4.331	.065	.984	.709	02	.079 - .118
R/LBU223.0750.1.22	4.724	.065	1.181	.787	02	.079 - .118

State R or L version

w see indexable circlip inserts

Dimensions in inch

Further sizes upon request

For torque specification of the screw, please see Technical Instructions.

Spare Parts

Toolholder	Clamping Screw	TORX PLUS® Wrench
R/LBU223...22	5.11T15P	T15PQ

Toolholder

B223

with through coolant supply

Bore \varnothing from
Circlip grooves
Clamping range

18 mm
DIN 471/472
2 - 2.9 mm

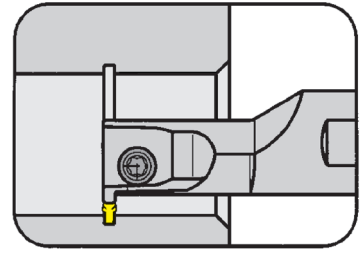

for Indexable insert

Type S223
S123

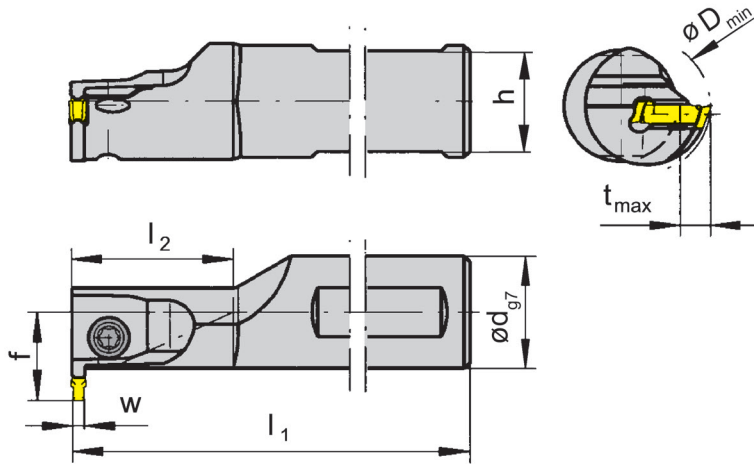

R = right hand version shown

L = left hand version

Part number	d	l ₁	l ₂	h	f	t _{max}	D _{min}	Size	Clamping range
R/LB223.0016.1.22	16	110	25	14	13.0	1.65	18	02	2.00 - 2.99
R/LB223.0020.1.22	20	120	30	18	15.7	1.65	20	02	2.00 - 2.99

State R or L version

w see indexable inserts

Dimensions in mm

Further sizes upon request

For torque specification of the screw, please see Technical Instructions.

Spare Parts

Toolholder	Clamping Screw	TORX PLUS® Wrench
R/LB223...	5.11T15P	T15PL

Grooving and Side Turning (internal)



Toolholder

BU223

Bore \varnothing from	.709"
Depth of groove up to	.248"
Clamping range up to	.118"

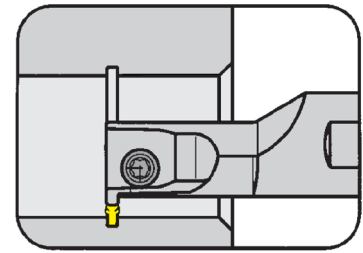

for Indexable insert

Type S223
S123

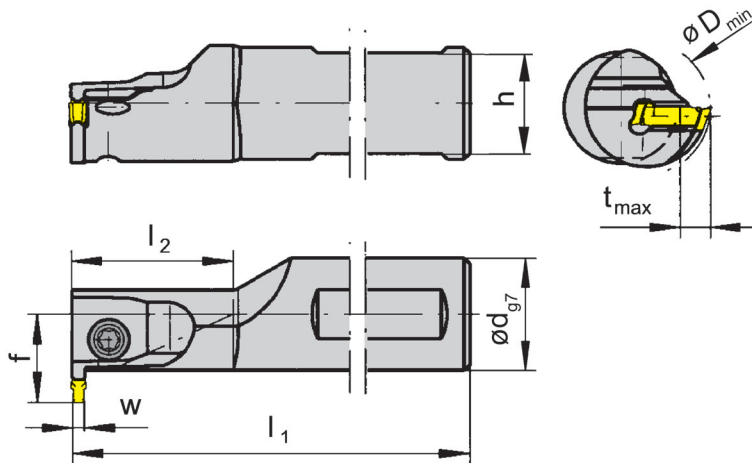

R = right hand version shown

L = left hand version

Part number	l_1	t_{max}	l_2	D_{min}	Size	Clamping range
R/LBU223.0625.1.42	4.331	.177	.984	.709	02	.079 - .118
R/LBU223.0750.1.52	4.724	.209	1.181	.787	02	.079 - .118
R/LBU223.1000.1.62	6.004	.248	1.969	.984	02	.079 - .118
R/LBU223.0625.1.43	4.331	.177	.984	.709	03	.118 - .118
R/LBU223.0750.1.53	4.724	.209	1.181	.787	03	.118 - .118
R/LBU223.1000.1.63	6.004	.248	1.969	.984	03	.118 - .118

State R or L version

w see inserts

Dimensions in inch

Further sizes upon request

For torque specification of the screw, please see Technical Instructions.

Spare Parts

Toolholder	Clamping Screw	TORX PLUS® Wrench
LBU223...	5.11T15P	T15PQ

Grooving and Side Turning (internal)



Toolholder

B223

with through coolant supply

Bore \varnothing from
Depth of groove up to
Clamping range

18 mm
6.3 mm
2 - 3 mm

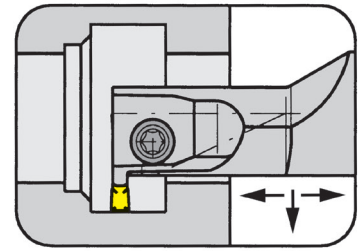

for Indexable insert

Type S223
S123

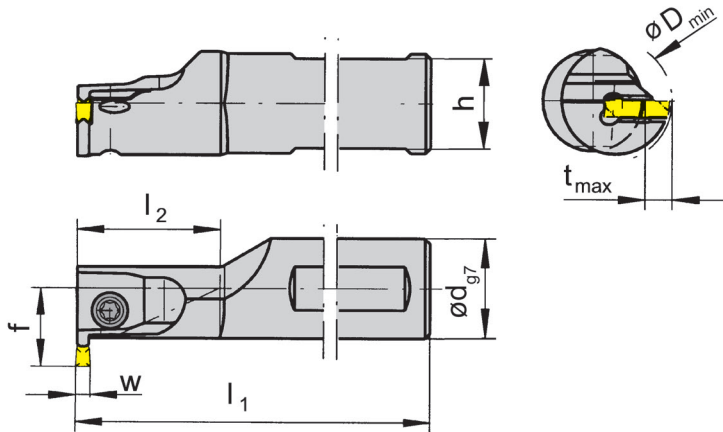

R = right hand version shown

L = left hand version

Part number	d	l ₁	l ₂	h	f	t _{max}	D _{min}	Size	Clamping range
R/LB223.0016.1.42	16	110	25	14	13.0	4.5	18	02	2.00 - 2.99
R/LB223.0020.1.52	20	120	30	18	15.7	5.3	20	02	2.00 - 2.99
R/LB223.0025.1.62	25	150	50	23	18.8	6.3	25	02	2.00 - 2.99
R/LB223.0016.1.43	16	110	25	14	13.0	4.5	18	03	3.00 - 3.00
R/LB223.0020.1.53	20	120	30	18	15.7	5.3	20	03	3.00 - 3.00
R/LB223.0025.1.63	25	150	50	23	18.8	6.3	25	03	3.00 - 3.00

State R or L version

w see indexable inserts

Dimensions in mm

Further sizes upon request

For torque specification of the screw, please see Technical Instructions.

Spare Parts

Toolholder	Clamping Screw	TORX PLUS® Wrench
R/LB223...	5.11T15P	T15PL

Grooving and Side Turning (internal)



Toolholder

BU223

with through coolant supply

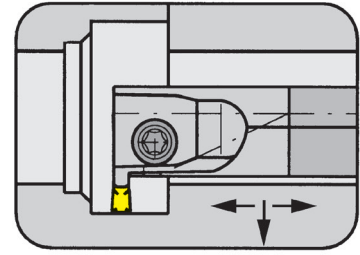

Bore \varnothing from	.709"
Depth of groove up to	.248"
Clamping range up to	.118"

for Indexable insert

Type S223
S123

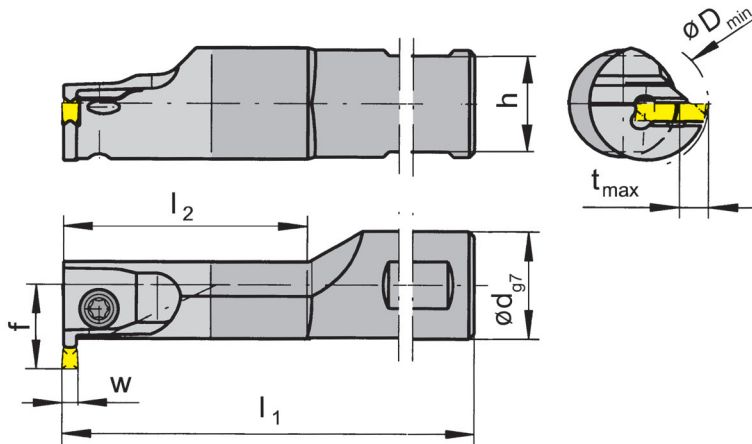

Carbide shank

R = right hand version shown

L = left hand version

Part number	d	l ₁	l ₂	h	f	t _{max}	D _{min}	Size	Clamping range
R/LBU223.HM06.2.42	.625	5.118	2.000	.546	.512	.177	.709	02	.079 - .118
R/LBU223.HM07.2.52	.750	5.906	2.500	.671	.618	.209	.787	02	.079 - .118
R/LBU223.HM10.2.62	1.000	6.299	2.776	.921	.740	.248	.984	02	.079 - .118
R/LBU223.HM06.2.43	.625	5.118	2.000	.546	.512	.177	.709	03	.118 - .118
R/LBU223.HM07.2.53	.750	5.906	2.500	.671	.618	.209	.787	03	.118 - .118
R/LBU223.HM10.2.63	1.000	6.299	2.756	.921	.740	.248	.984	03	.118 - .118

State R or L version

w see indexable inserts

Dimensions in inch

Further sizes upon request

For torque specification of the screw, please see Technical Instructions.

Spare Parts

Toolholder	Clamping Screw	TORX PLUS® Wrench
R/LBU223...	5.11T15P	T15PL

Grooving and Side Turning (internal)



Toolholder

B223

with through coolant supply

Bore \varnothing from
Depth of groove up to
Clamping range

18 mm
6.3 mm
2 - 3 mm

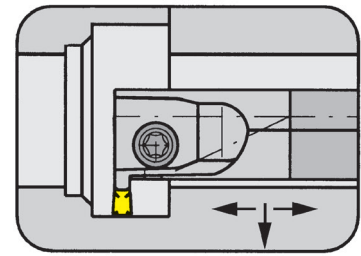

for Indexable insert

Type S223
S123

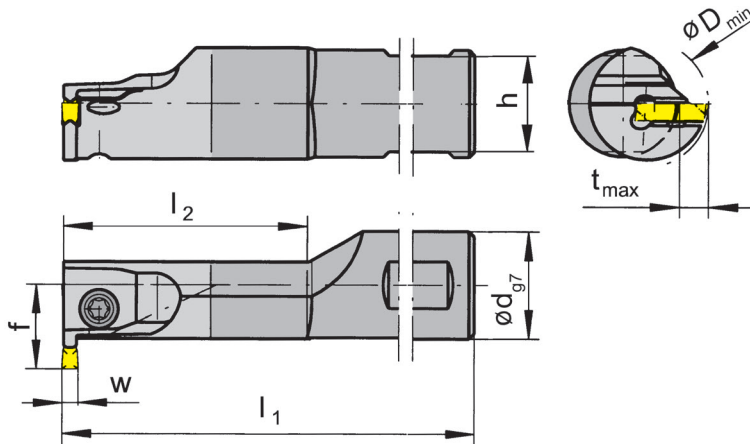

R = right hand version shown

L = left hand version

Carbide shank

Part number	d	l ₁	l ₂	h	f	t _{max}	D _{min}	Size	Clamping range
R/LB223.HM16.2.42	16	130	50	14	13.0	4.5	18	02	2.00 - 2.99
R/LB223.HM20.2.52	20	150	60	18	15.7	5.3	20	02	2.00 - 2.99
R/LB223.HM25.2.62	25	160	70	23	18.8	6.3	25	02	2.00 - 2.99
R/LB223.HM16.2.43	16	130	50	14	13.0	4.5	18	03	3.00 - 3.00
R/LB223.HM20.2.53	20	150	60	18	15.7	5.3	20	03	3.00 - 3.00
R/LB223.HM25.2.63	25	160	70	23	18.8	6.3	25	03	3.00 - 3.00

State R or L version

w see indexable inserts

Dimensions in mm

Further sizes upon request

For torque specification of the screw, please see Technical Instructions.

Spare Parts

Toolholder	Clamping Screw	TORX PLUS® Wrench
R/LB223...	5.11T15P	T15PL

Basic toolholder

BU223

without cassette

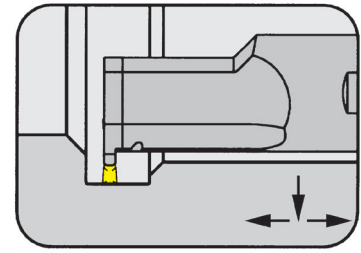

Bore \varnothing	1.102"
Depth of groove up to	.248"
Width of groove	.118"

with through coolant supply

for Cassette

Type BK223

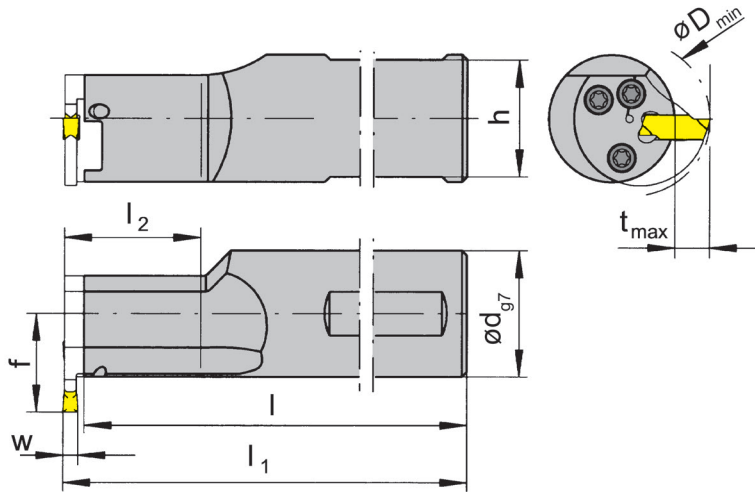

R = right hand version shown

L = left hand version

Part number	l_1	d	l	l_2	h	f
R/LBU223.1000.1K2	$l+b_1+w/2$	1.00	4.571	1.181	.921	.768
R/LBU223.1000.2K2	$l+b_1+w/2$	1.00	5.831	2.362	.921	.768
R/LBU223.1250.1K2	$l+b_1+w/2$	1.25	5.831	1.181	1.171	.906
R/LBU223.1250.2K2	$l+b_1+w/2$	1.25	6.843	2.362	1.171	.906

State R or L version

w see indexable inserts

Dimensions in inch

Further sizes upon request

Note:

Dimensions for D_{min} , t_{max} and b_1 see cassettes

For torque specification of the screw, please see Technical Instructions.

Spare Parts

Basic toolholder	Clamping Screw	TORX PLUS® Wrench
R/LBU223...	4.09T15P	T15PL

Basic toolholder

B223

without cassette

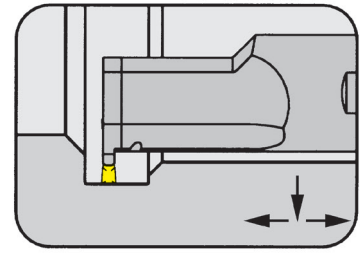

Bore \varnothing	28 mm
Depth of groove up to	6.3 mm
Width of groove	2 - 3 mm

with through coolant supply

for Cassette

Type BK223

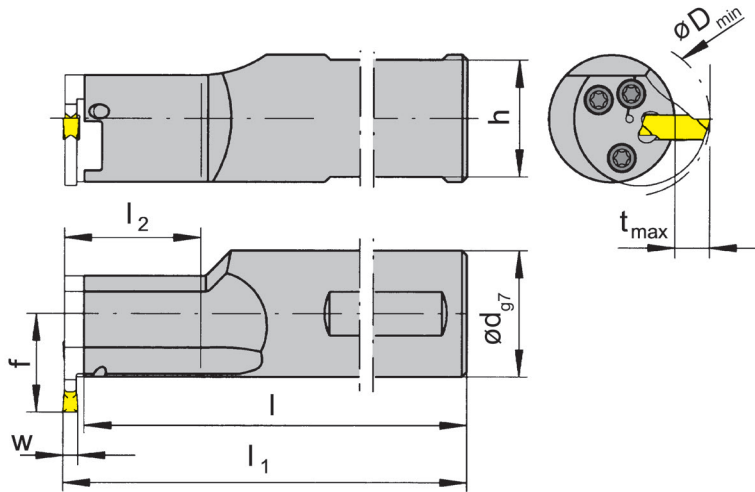

R = right hand version shown

L = left hand version

Part number	l_1	d	l	l_2	h	f
R/LB223.0025.1.K2	$l+b_1+w/2$	25	116.1	30	23	19.5
R/LB223.0025.2.K2	$l+b_1+w/2$	25	146.1	60	23	19.5
R/LB223.0032.1.K2	$l+b_1+w/2$	32	146.1	30	30	23.0
R/LB223.0032.2.K2	$l+b_1+w/2$	32	176.1	60	30	23.0

State R or L version

w see indexable inserts

Dimensions in mm

Further sizes upon request

Note:

Dimensions for D_{min} , t_{max} and b_1 see cassettes

For torque specification of the screw, please see Technical Instructions.

Spare Parts

Basic toolholder	Clamping Screw	TORX PLUS® Wrench
R/LB223...	4.09T15P	T15PL

Cassette

BK223

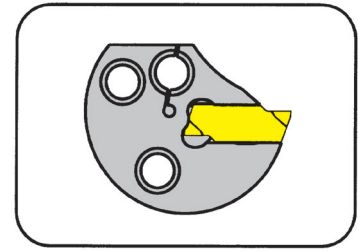

Bore \varnothing	28 mm
Depth of groove up to	6.3 mm
Clamping range	2 - 3 mm

for Indexable insert

Type S223

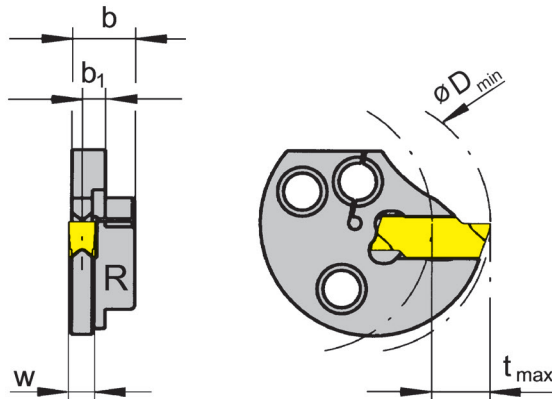

R = right hand version shown

L = left hand version

Part number	D_{min}	t_{max}	b	b_1	Size	Clamping range
R/LBK223.0028.01	28	6.3	7.4	3.10	01	2.0-2.0
R/LBK223.0028.02	28	6.3	7.4	2.95	02	2.5-2.5
R/LBK223.0028.03	28	6.3	7.4	2.70	03	3.0-3.0

State R or L version

w see indexable inserts

Dimensions in mm

Use right hand cassettes in right hand basic toolholders and left hand cassettes in left hand basic toolholders.

Spare Parts

The fastening screw is combined with the basic toolholder - no separate order required.

Insert

S119

Depth of groove up to
Width of groove

.118"
.079 - .118"

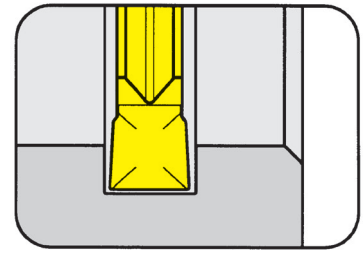

for Toolholder

Type B119

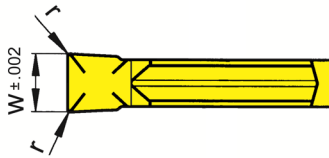
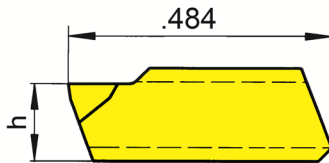

Part number	w	r	h ₁	Size	TN35
S119.0200.32	.079	.008	.144	02	▲
S119.0250.32	.098	.008	.148	02	▲
S119.0300.32	.118	.008	.156	03	▲
					P ●
					M ●
					K ●
					N ●
					S ●
					H -

▲ on stock Δ 4 weeks x upon request

- recommended
- alternative recommendation
- not suitable

- uncoated grades
- coated grades
- brazed/Cermet

Dimensions in inch

Carbide grades

Indexable inserts can be used in **right and left** hand toolholders.

Insert

S123

Depth of groove up to .984"
Width of groove .079 - .118"

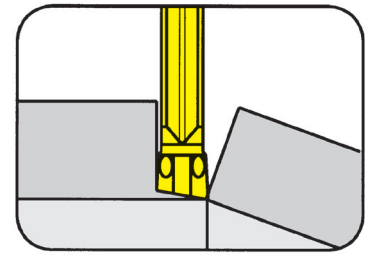

for Toolholder

Type H223
HU223

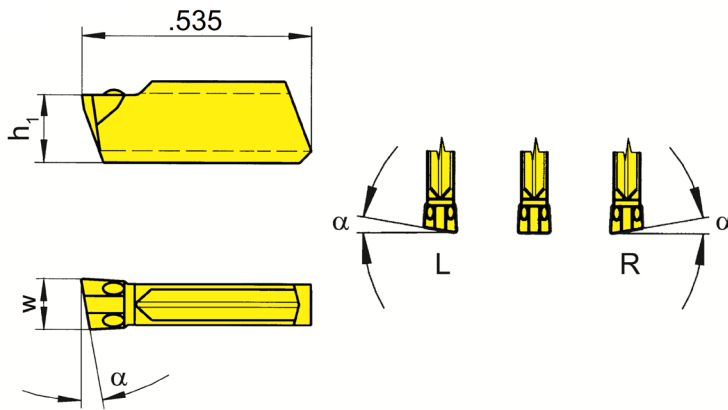

R = right hand version shown

L = left hand version

Part number	w	α	h ₁	Size	TF45	TI25	TN35
S123.0020.C0	.079	0°	.144	01	Δ	x	Δ
R/LS123.0420.C0	.079	4°	.144	01	x/x	x/x	x/x
R/LS123.0820.C0	.079	8°	.144	01	x/x	x/▲	Δ/x
R/LS123.1520.C0	.079	15°	.144	01	▲/x	x/▲	Δ/x
S123.0030.C0	.118	0°	.156	03	x	x	Δ
R/LS123.0430.C0	.118	4°	.156	03	x/x	x/x	x/x
R/LS123.0830.C0	.118	8°	.156	03	x/x	x/x	x/x

▲ on stock Δ 4 weeks x upon request

● recommended
o alternative recommendation
- not suitable

□ uncoated grades
■ coated grades
■ brazed/Cermet

Dimensions in inch

State R or L version

Indexable inserts can be used in **right and left** hand toolholders.

	P	M	K	N	S	H
TF45	●	●	●	●	●	-
TI25	●	●	●	●	●	-
TN35	●	●	●	●	●	-

Carbide grades

Insert

S123

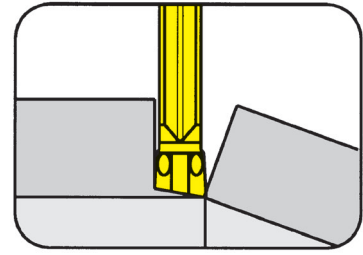

for Toolholder

Type H223
HU223

Depth of groove up to	.984"
Width of groove	.079 - .118"

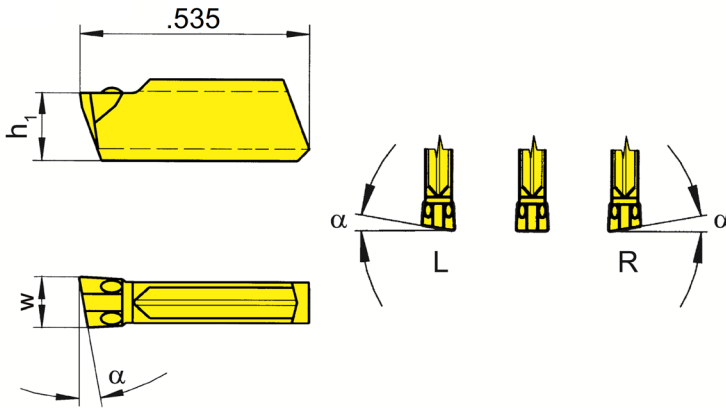

R = right hand version shown

L = left hand version

Part number	w	r	α	h ₁	Size	TF45	TI25	TN35
S123.0020.C1	.079	.006	0°	.144	01	Δ	Δ	Δ
R/LS123.0820.C1	.079	.006	8°	.144	01	x/x	x/x	x/x
R/LS123.1520.C1	.079	.006	15°	.144	01	x/x	x/x	x/x
S123.0030.C1	.118	.006	0°	.156	03	x	x	x
R/LS123.0430.C1	.118	.006	4°	.156	03	x/x	x/x	x/x
R/LS123.0830.C1	.118	.006	8°	.156	03	Δ/x	x/x	x/x

▲ on stock Δ 4 weeks x upon request

● recommended
o alternative recommendation
- not suitable

□ uncoated grades
■ coated grades
■ brazed/Cermet

Dimensions in inch

State R or L version

Indexable inserts can be used in **right and left** hand toolholders.

	P	M	K	N	S	H
TF45	•	•	•	•	•	•
TI25	•	•	•	•	•	•
TN35	•	•	•	•	•	•

Carbide grades

Indexable insert

S223

Depth of groove up to $.433''$
 Width of groove $.079 - .118''$

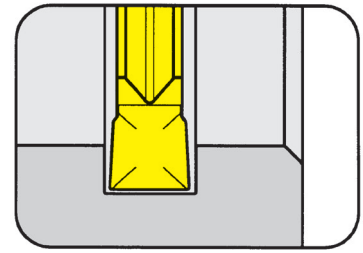

for Toolholder

- Type H223
 HU223
 E223
 B223
 BU223
 BK223

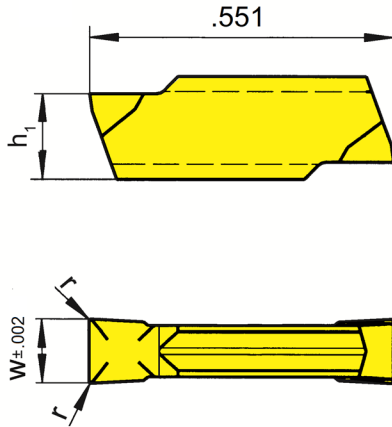

Part number	w	r	h ₁	Size	Carbide grades			
					MG12	H54	Ti25	TN35
S223.0200.32	.079	.008	.144	01	▲	▲	▲	▲
S223.0250.32	.098	.008	.148	02	▲	▲	▲	▲
S223.0300.32	.118	.008	.156	03	▲	▲	▲	▲
					P	○	●	●
					M	-	●	●
					K	-	-	●
					N	-	-	●
					S	-	-	●
					H	-	-	-

- ▲ on stock Δ 4 weeks x upon request
- recommended
- alternative recommendation
- not suitable
- uncoated grades
- coated grades
- brazed/Cermet

Dimensions in inch

Carbide grades

Indexable inserts can be used in right and left hand toolholders.

Indexable insert

S223

not face cutting, limited depth of cut

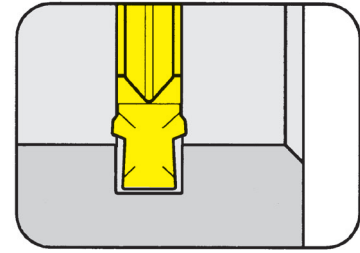

Circlip grooves
Width of circlip Nw

DIN 471/472
.043 - .085"

for Toolholder

Type H223
HU223
E223
B223...1.22
BU223...1.22

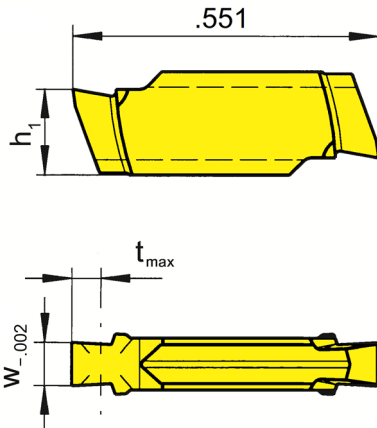

Part number	w	Nw	t _{max}	h ₁	Size	TN35
S223.0110.32	.049	.043	.024	.148	02	▲
S223.0130.32	.057	.051	.043	.148	02	▲
S223.0160.32	.069	.063	.045	.148	02	▲
S223.0185.32	.078	.073	.055	.148	02	▲
S223.0215.32	.090	.085	.065	.148	02	▲

▲ on stock Δ 4 weeks x upon request

● recommended

o alternative recommendation

- not suitable

□ uncoated grades

■ coated grades

■ brazed/Cermet

Dimensions in inch

P	●
M	●
K	●
N	●
S	●
H	-

Carbide grades

Indexable inserts can be used in right and left hand toolholders.

Indexable insert

S223

Depth of groove up to .433"
Width of groove .079 - .118"

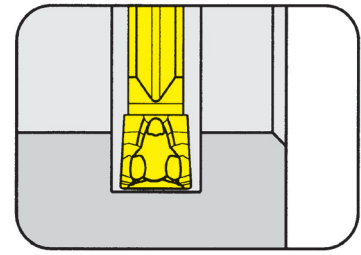

for Toolholder

- Type H223
HU223
E223
B223
BU223
BK223

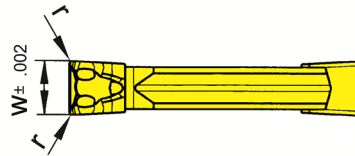
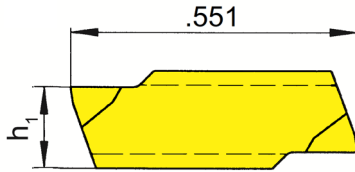

Part number	w	r	h ₁	Size	Carbide grades	
					TH35	T125
S223.0200.52	.079	.008	.144	01	▲	●
S223.0250.52	.098	.008	.148	02	●	▲
S223.0300.52	.118	.008	.156	03	▲	x

▲ on stock Δ 4 weeks x upon request

- recommended
- alternative recommendation
- not suitable

- uncoated grades
- coated grades
- brazed/Cermet

Dimensions in inch

Carbide grades

Indexable inserts can be used in right and left hand toolholders.

Indexable insert

S223

with chip forming

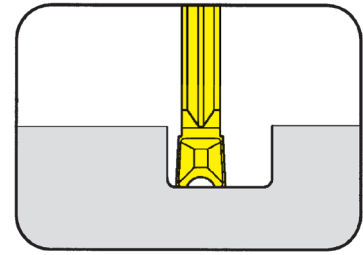

Depth of groove up to	.394"
Width of groove	.079"

precision ground

for Toolholder

Type H223
HU223
E223
B223
BU223
BK223

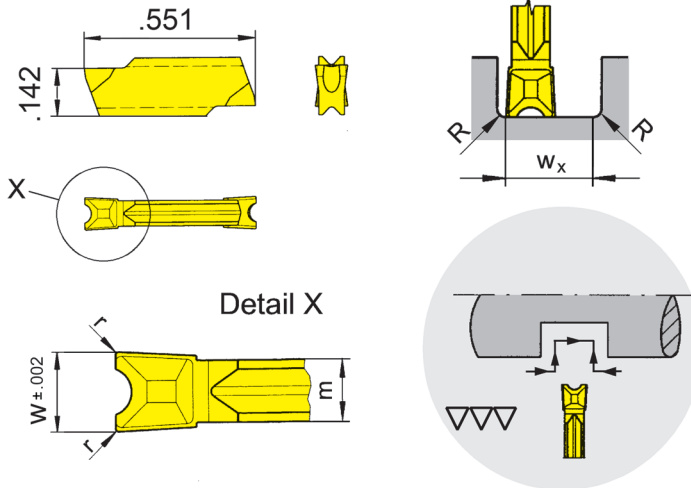

Part number	w	r	t _{max}	w _x	Size	T125
S223.NC20.D2	.079	.008	.394	.106	01	▲

▲ on stock Δ 4 weeks x upon request

- recommended
- alternative recommendation
- not suitable

□ uncoated grades

■ coated grades

■ brazed/Cermet

Dimensions in inch

P	•
M	•
K	•
N	•
S	•
H	-

Carbide grades

$$w_x = \text{width of groove} - R_{(\text{right})} - R_{(\text{left})}$$

Indexable inserts can be used in right and left hand toolholders.

Indexable insert

S223

Depth of groove up to .433"
Width of groove .079 - .118"

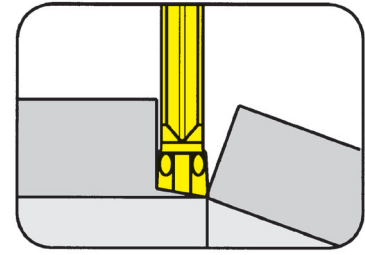

for Toolholder

Type H223
HU223

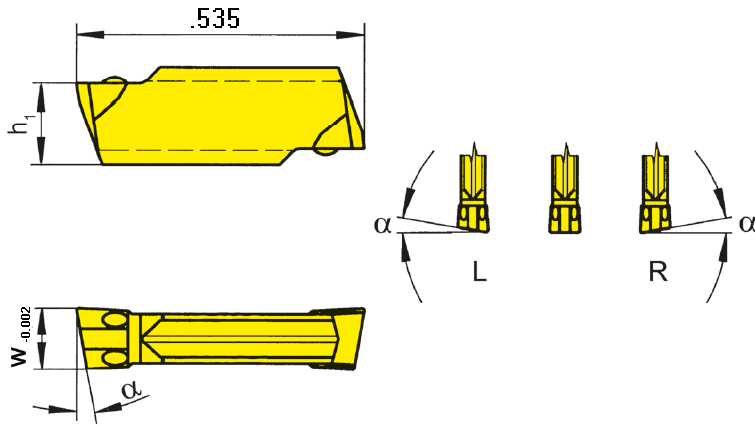

R = right hand version shown

L = left hand version

Part number	w	α	h ₁	Size	TF45	TI25	TN35
S223.0020.C0	.079	0°	.144	01	▲	▲	▲
R/LS223.0420.C0	.079	4°	.144	01	x/▲	▲/▲	▲/▲
R/LS223.0820.C0	.079	8°	.144	01	▲/Δ	▲/▲	▲/▲
R/LS223.1520.C0	.079	15°	.144	01	▲/x	▲/▲	▲/▲
S223.0025.C0	.098	0°	.148	02	x	▲	x
R/LS223.0425.C0	.098	4°	.148	02	x/x	▲/x	▲/Δ
R/LS223.0825.C0	.098	8°	.148	02	▲/x	▲/x	▲/Δ
S223.0030.C0	.118	0°	.156	03	Δ	▲	▲
R/LS223.0430.C0	.118	4°	.156	03	x/x	x/x	Δ/Δ
R/LS223.0830.C0	.118	8°	.156	03	Δ/x	▲/▲	▲/▲
					P	•	•
					M	•	•
					K	•	•
					N	•	•
					S	•	•
					H	-	-

▲ on stock Δ 4 weeks x upon request
● recommended
○ alternative recommendation
- not suitable
■ uncoated grades
■ coated grades
■ brazed/Cermet

Carbide grades

State R or L version

Indexable inserts can be used in right and left hand toolholders.

Indexable insert

S223

Depth of groove up to
Width of groove

.433"
.079 - .118"

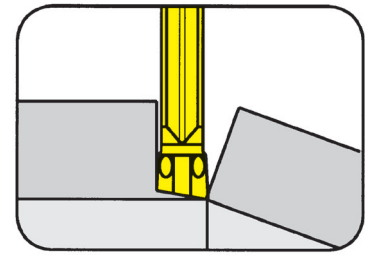

for Toolholder

Type H223
HU223

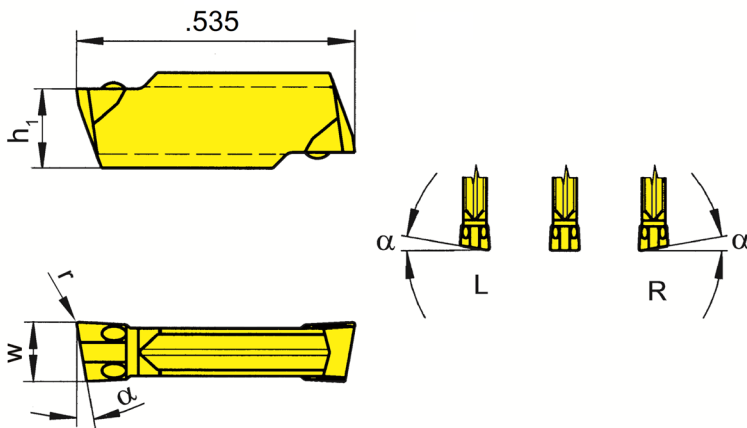

R = right hand version shown

L = left hand version

Part number	w	r	α	h ₁	Size	Carbide grades		
						TF45	TI25	TN35
S223.0020.C1	.079	.006	0°	.144	01	▲	▲	▲
R/LS223.0420.C1	.079	.006	4°	.144	01	▲/x	Δ/x	▲/Δ
R/LS223.0820.C1	.079	.006	8°	.144	01	Δ/x	▲/x	▲/▲
R/LS223.1520.C1	.079	.006	15°	.144	01	▲/▲	▲/▲	▲/▲
S223.0025.C1	.098	.006	0°	.148	02	▲	▲	▲
R/LS223.0425.C1	.098	.006	4°	.148	02	x/x	▲/x	x/Δ
R/LS223.0825.C1	.098	.006	8°	.148	02	▲/x	▲/x	x/x
S223.0030.C1	.118	.006	0°	.156	03	▲	▲	▲
R/LS223.0430.C1	.118	.006	4°	.156	03	x/x	x/x	Δ/Δ
R/LS223.0830.C1	.118	.006	8°	.156	03	▲/x	▲/x	▲/x
						P	•	•
						M	•	•
						K	•	•
						N	•	•
						S	•	•
						H	-	-

▲ on stock Δ 4 weeks x upon request

● recommended

o alternative recommendation

- not suitable

■ uncoated grades

■ coated grades

■ brazed/Cermet

Dimensions in inch

State R or L version

Indexable inserts can be used in right and left hand toolholders.

Grooving and Side Turning (external)



Toolholder

HU223

Depth of groove up to
Clamping range

.394"
.079 - .118"

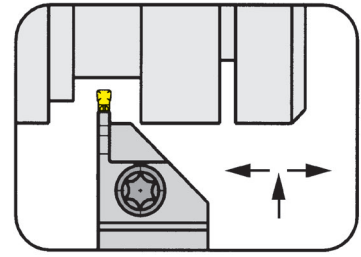

for Insert

Type S123
S223

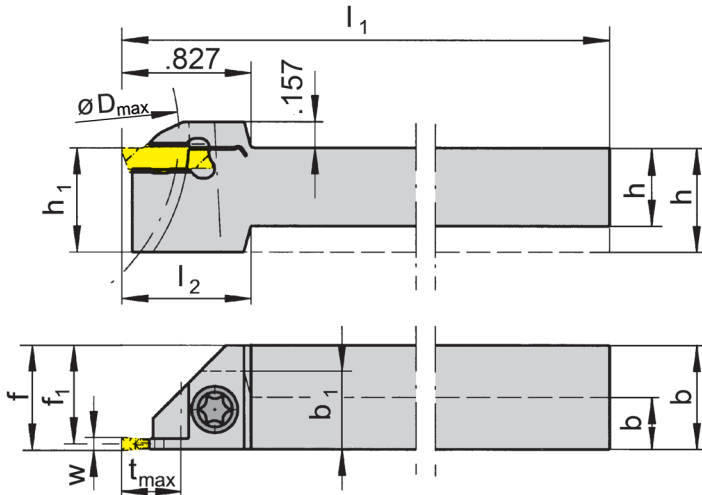

R = right hand version shown

L = left hand version

Part number	h	b	l_1	l_2	h_1	b_1	f	t_{max}	D_{max}	Size	Clamping range
R/LHU223.0375.01	.375	.375	3.150	.787	.472	.453	$f_1+w/2$.315	.984	01	.079
R/LHU223.0500.01	.500	.500	3.996	.827	.500	-	$f_1+w/2$.394	1.969	01	.079
R/LHU223.0625.01	.625	.625	5.118	.827	.625	-	$f_1+w/2$.394	1.969	01	.079
R/LHU223.0750.01	.750	.750	5.118	.827	.750	-	$f_1+w/2$.394	1.969	01	.079
R/LHU223.1000.01	1.000	1.000	6.004	.827	1.000	-	$f_1+w/2$.394	1.969	01	.079
R/LHU223.0375.02	.375	.375	3.150	.787	.472	.453	$f_1+w/2$.315	.984	02	.098
R/LHU223.0500.02	.500	.500	3.996	-	.500	-	$f_1+w/2$.394	1.969	02	.098
R/LHU223.0625.02	.625	.625	5.118	-	.625	-	$f_1+w/2$.394	1.969	02	.098
R/LHU223.0750.02	.750	.750	5.118	.827	.750	-	$f_1+w/2$.394	1.969	02	.098
R/LHU223.1000.02	1.000	1.000	6.004	.827	1.000	-	$f_1+w/2$.394	1.969	02	.098
R/LHU223.0500.03	.500	.500	3.996	.827	.500	-	$f_1+w/2$.394	1.969	03	.118
R/LHU223.0625.03	.625	.625	5.118	.827	.625	-	$f_1+w/2$.394	1.969	03	.118
R/LHU223.0750.03	.750	.750	5.118	.827	.750	-	$f_1+w/2$.394	1.969	03	.118
R/LHU223.1000.03	1.000	1.000	6.004	-	1.000	-	$f_1+w/2$.394	1.969	03	.118

State R or L version

w see indexable inserts

Dimensions in inch

Further sizes upon request

For torque specification of the screw, please see Technical Instructions.

Spare Parts

Toolholder	Clamping Screw	TORX PLUS® Wrench
R/LHU223...	5.11T15P	T15PL

C



209



D

Toolholder with Inserts

Width of groove .079 - .118"

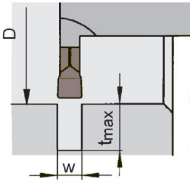
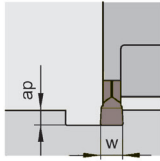

$w = .078 - .118" (2 - 3 \text{ mm})$ $w = .078 - .118" (2 - 3 \text{ mm})$
 $a_{p \text{ max}} = .039" (1 \text{ mm})$ $t_{\text{max}} = .197" (5 \text{ mm})$
 $D \geq .630" (16 \text{ mm})$

D

Toolholder
B209

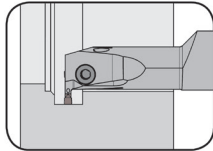

Page
D3

Indexable Insert
S209

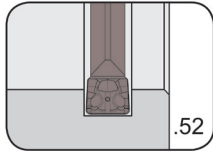

Page
D4

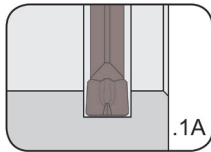

Page
D5

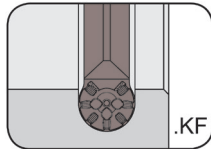

Page
D6

Grooving and Side Turning (internal)



Toolholder

B209

Bore \varnothing from	16 mm
Depth of groove up to	5 mm
Clamping range	3 mm

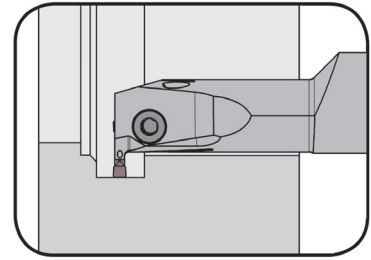

for Indexable insert

Type S209

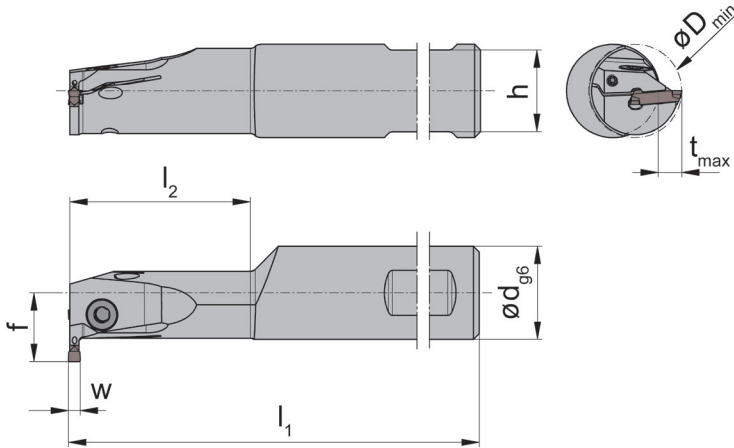

R = right hand version shown

L = left hand version

with through coolant supply

Part number	d	l ₁	l ₂	h	f	t _{max}	D _{min}	Size	Clamping range
R/LB209.0016.1.02.IK	16	110	30	14	11.8	3.5	16	20	2.0 - 2.4
R/LB209.0020.1.12.IK	20	110	30	18	15.3	5.0	18	20	2.0 - 2.4
R/LB209.0016.1.025.IK	16	110	30	14	11.8	3.5	16	25	2.5 - 3.0
R/LB209.0020.1.125.IK	20	110	30	18	15.3	5.0	18	25	2.5 - 3.0
R/LB209.0016.1.03.IK	16	110	30	14	11.8	3.5	16	30	3.0 - 3.0
R/LB209.0020.1.13.IK	20	110	30	18	15.3	5.0	18	30	3.0 - 3.0

State R or L version

w see indexable inserts

Dimensions in mm

Further sizes upon request

For torque specification of the screw, please see Technical Instructions.

Spare Parts

Toolholder	Threaded Pin	Clamping Screw	TORX PLUS® Wrench
R/LB209...	2.03.913	3.5.12T10EP	T10PL

Indexable insert

S209

with chip forming

Width of groove .079 - .118"

precision sintered

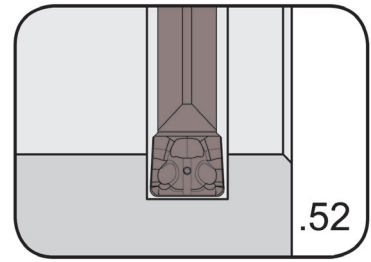

for Toolholder

Type B209

D

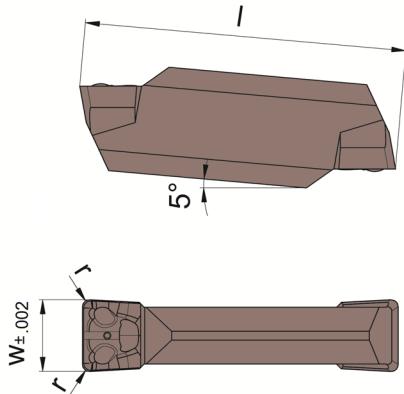

Indexability length $\pm .002''$

Part number	w	r	l	Size	AS45
S209.0200.52	.079	.008	.354	20	▲
S209.0250.52	.098	.008	.394	25	▲
S209.0300.52	.118	.008	.394	30	▲

▲ on stock Δ 4 weeks x upon request

- recommended
- alternative recommendation
- not suitable

- uncoated grades
- coated grades
- brazed/Cermet

Dimensions in inch

P	●
M	●
K	●
N	○
S	●
H	-

Carbide grades

Indexable inserts can be used in right and left hand toolholders.

Indexable insert

S209

with chip forming

Width of groove	.079 - .118"
-----------------	--------------

precision sintered

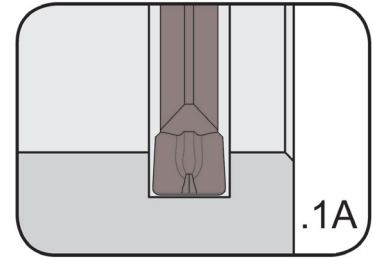

for Toolholder

Type B209

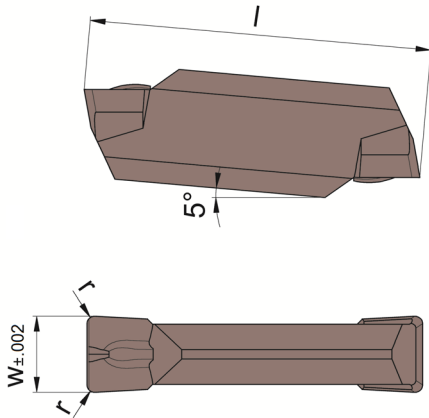

Indexability length $\pm .002''$

Part number	w	r	l	Size	AS45
S209.0200.1A2	.079	.008	.354	20	▲
S209.0250.1A2	.098	.008	.394	25	▲
S209.0300.1A2	.118	.008	.394	30	▲

▲ on stock Δ 4 weeks x upon request

- recommended
- alternative recommendation
- not suitable

- uncoated grades
- coated grades
- brazed/Cermet

Dimensions in inch

P	●
M	●
K	●
N	○
S	●
H	-

Carbide grades

Indexable inserts can be used in right and left hand toolholders.



Indexable insert

S209

with chip forming

Width of groove	.079 - .118"
Full radius	.039 - .059"

precision sintered

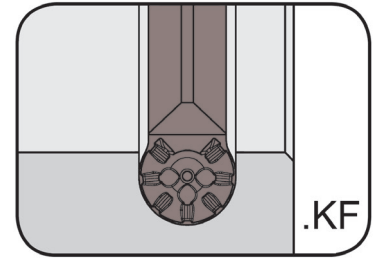

for Toolholder

Type B209

D

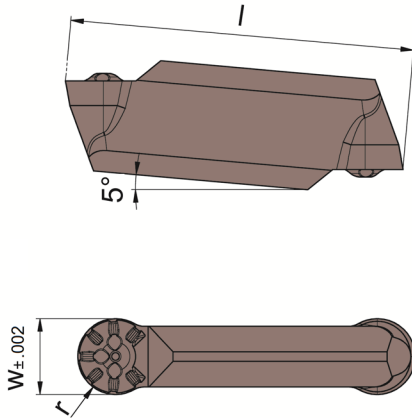

Indexability length $\pm .002''$

Part number	w	l	r	Size	AS45
S209.0010.KF2	.079	.354	.039	20	▲
S209.0015.KF3	.118	.394	.059	30	▲

▲ on stock Δ 4 weeks x upon request

- recommended
- alternative recommendation
- not suitable

- uncoated grades
- coated grades
- brazed/Cermet

Dimensions in inch

P	●
M	●
K	●
N	○
S	●
H	-

Carbide grades

Indexable inserts can be used in right and left hand toolholders.

216



Toolholder with Inserts

Width of groove .079 - .236"

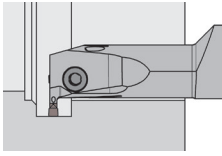

$D_{\min} = .787" (20 \text{ mm})$
 $t_{\max} = .295" (7.5 \text{ mm})$

Toolholder
B216

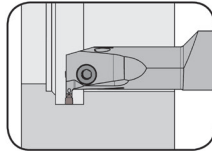

Page
E3

Indexable Insert
S216

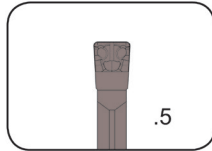

Page
E4

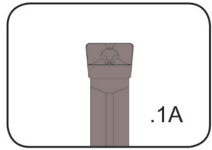

Page
E5

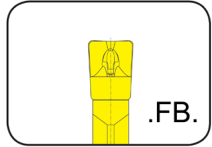

Page
E6

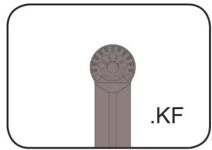

Page
E7

E

Grooving and Side Turning (internal)



Toolholder

B216

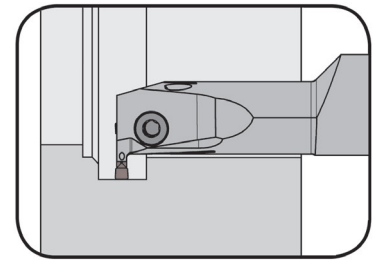

Bore \varnothing from 20 mm
 Depth of groove up to 7.5 mm
 Clamping range 2 - 6.1 mm

for Indexable insert

Type S216

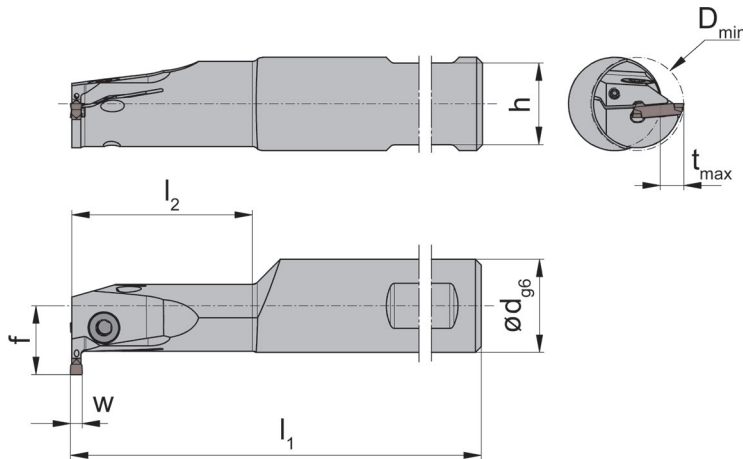

R = right hand version shown

L = left hand version

with through coolant supply

Part number	d	l ₁	l ₂	h	f	t _{max}	D _{min}	Size	Clamping range
R/LB216.0020.1.22.IK	20	110	30	18	16.3	6.0	20	20	2.0-2.4
R/LB216.0025.2.22.IK	25	150	50	23	20.3	7.5	25	20	2.0-2.4
R/LB216.0025.23.1.22.IK	25	150	30	23	19.8	7.0	23	20	2.0-2.4
R/LB216.0020.1.225.IK	20	110	30	18	16.3	6.0	20	25	2.4-2.8
R/LB216.0025.2.225.IK	25	150	50	23	20.3	7.5	25	25	2.4-2.8
R/LB216.0025.23.1.225.IK	25	150	30	23	19.8	7.0	23	25	2.4-2.8
R/LB216.0020.1.23.IK	20	110	30	18	16.3	6.0	20	30	2.8-3.7
R/LB216.0025.2.23.IK	25	150	50	23	20.3	7.5	25	30	2.8-3.7
R/LB216.0025.23.1.23.IK	25	150	30	23	19.8	7.0	23	30	2.8-3.7
R/LB216.0020.1.24.IK	20	110	30	18	16.3	6.0	20	40	3.7-4.4
R/LB216.0025.2.24.IK	25	150	50	23	20.3	7.5	25	40	3.7-4.4
R/LB216.0025.23.1.24.IK	25	150	30	23	19.8	7.0	23	40	3.7-4.4
R/LB216.0025.23.1.25.IK	25	150	30	23	19.8	7.0	23	50	4.4-5.1
R/LB216.0025.23.1.26.IK	25	150	30	23	19.8	7.0	23	60	5.1-6.1

State R or L version

w see indexable inserts

Dimensions in mm

Further sizes upon request

For torque specification of the screw, please see Technical Instructions.

Spare Parts

Toolholder	Threaded Pin	Clamping Screw	TORX PLUS® Wrench
R/LB216.1/.23...IK	2.03.913	3.5.12T10EP	T10PL
R/LB216.0025.2.22/.23/.24/.225.IK	2.03.913	5.13T20EP	T20PQ

Indexable insert

S216

with chip forming

Width of groove	.079 - .236"
-----------------	--------------

precision sintered

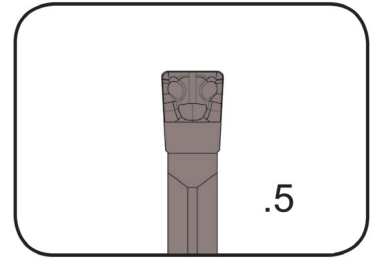

for Toolholder

Type B216

E

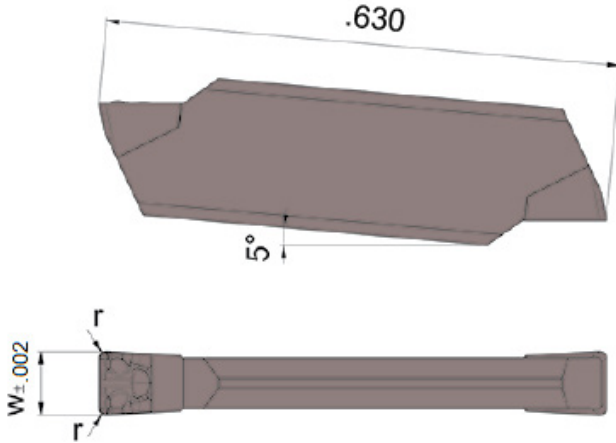

Indexability length $\pm .004''$

Part number	w	r	Size	AS45
S216.0200.52	.079	.008	20	▲
S216.0250.52	.098	.008	25	▲
S216.0300.52	.118	.008	30	▲
S216.0400.52	.157	.008	40	▲
S216.0500.54	.197	.016	50	△
S216.0600.54	.236	.016	60	△

▲ on stock △ 4 weeks x upon request

- recommended
- alternative recommendation
- not suitable

- uncoated grades
- coated grades
- brazed/Cermet

Dimensions in inch

P	●
M	●
K	●
N	○
S	●
H	-

Carbide grades

Indexable inserts can be used in right and left hand toolholders.

Indexable insert

S216

with chip forming

Width of groove	.079 - .236"
-----------------	--------------

precision sintered

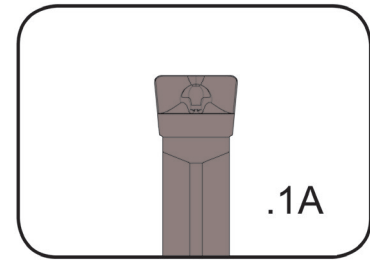

for Toolholder

Type B216

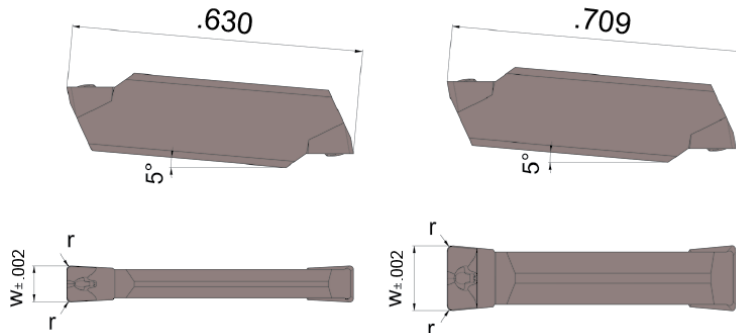

Width of groove .079 - .157"

Width of groove .197 - .236"

Indexability length $\pm .004$ "

Part number	w	r	Size	AS45
S216.0200.1A2	.079	.008	20	▲
S216.0250.1A2	.098	.008	25	△
S216.0300.1A2	.118	.008	30	▲
S216.0400.1A2	.157	.008	40	▲
S216.0500.1A4	.197	.016	50	△
S216.0600.1A4	.236	.016	60	△

▲ on stock △ 4 weeks x upon request

● recommended
○ alternative recommendation
- not suitable

□ uncoated grades

■ coated grades

■ brazed/Cermet

Dimensions in inch

P	●
M	●
K	●
N	○
S	●
H	-

Carbide grades

Indexable inserts can be used in right and left hand toolholders.



Indexable insert

S216

with chip forming

Width of groove	.079"
-----------------	-------

Precision Ground

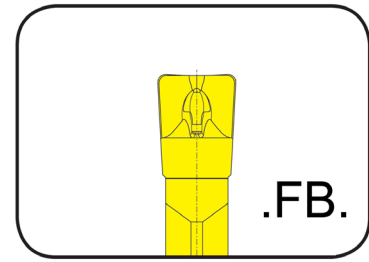

for Toolholder

Type B216

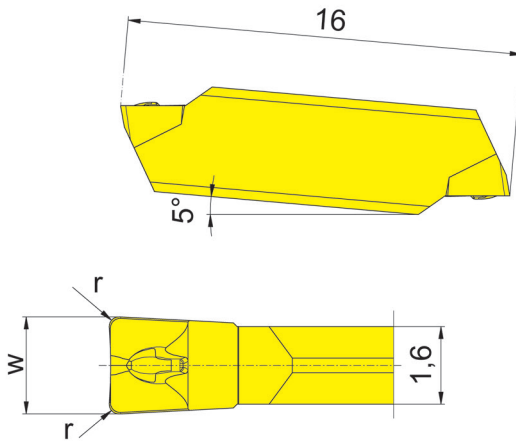

E

Part number	w	r	Size	EG35
S216.FB20.02	.079	.008	20	▲
				P ●
				M ●
				K ○
				N -
				S -
				H -

▲ on stock Δ 4 weeks x upon request

- recommended
- alternative recommendation
- not suitable

- uncoated grades
- coated grades
- brazed/Cermet

Dimensions in inch

Carbide grades

Indexable inserts can be used in right and left hand toolholders.

Indexable insert

S216

with chip forming

Width of groove	.079 - .157"
Full radius	.039 - .079"

precision sintered

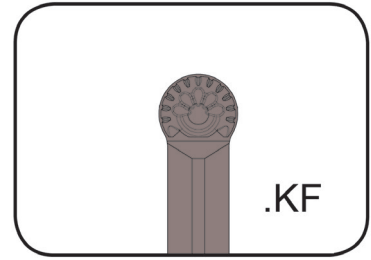

for Toolholder

Type B216

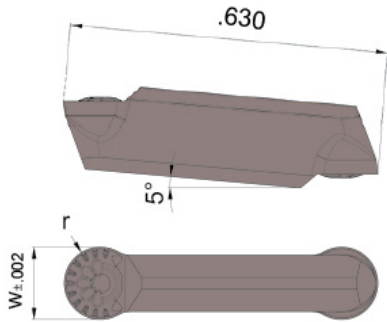

Indexability length $\pm .004''$

Part number	w	r	Size	AS45
S216.0010.KF2	.079	.039	20	▲
S216.0015.KF3	.118	.059	30	▲
S216.0020.KF4	.157	.079	40	▲

▲ on stock Δ 4 weeks x upon request

- recommended
- alternative recommendation
- not suitable

- uncoated grades
- coated grades
- brazed/Cermet

Dimensions in inch

P	●
M	●
K	●
N	○
S	●
H	-

Carbide grades

Indexable inserts can be used in right and left hand toolholders.



217



Toolholder with Inserts

Width of groove .020 - .209"

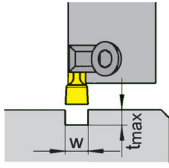

w = .02 - .209 (0.5 - 5.3 mm)
t_{max} = .157" (4mm)

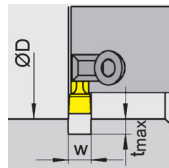

w = .02 - .209" (0.5 - 5.3 mm)
t_{max} = .185" (4.7 mm)
D ≥ .787" (20 mm)

Toolholder
U240/240/U248/248

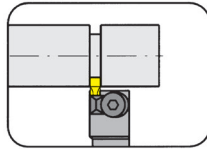

Page
F3-F8

Indexable Insert
217

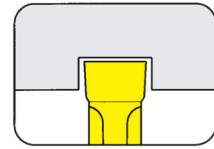

Page
F19-F20

Toolholder
U230/230/U250/250

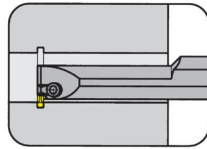

Page
F9-F10

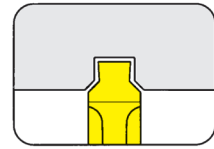

Page
F21

Toolholder
U233/233/U253/253

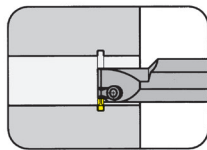

Page
F11-F12

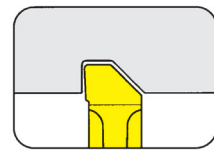

Page
F22

Toolholder
234/U254/254

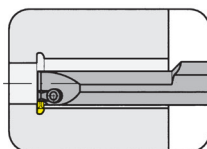

Page
F13-F14

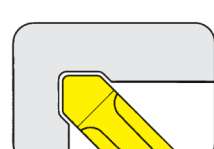

Page
F23

Toolholder
U235/235/U255/255

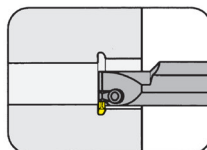

Page
F15-F16

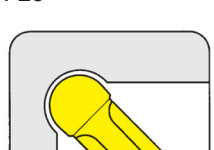

Page
F24

Toolholder
U245/245

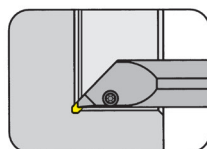

Page
F17-F18

Cartridge
232

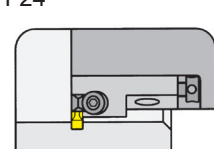

Page
F25

F

Grooving (external)



Toolholder

U240

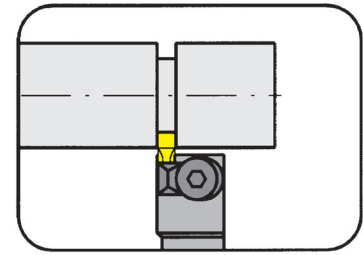

Depth of groove up to $.157''$
Clamping range $.020 - .106''$

for Indexable insert

Type 217
U217

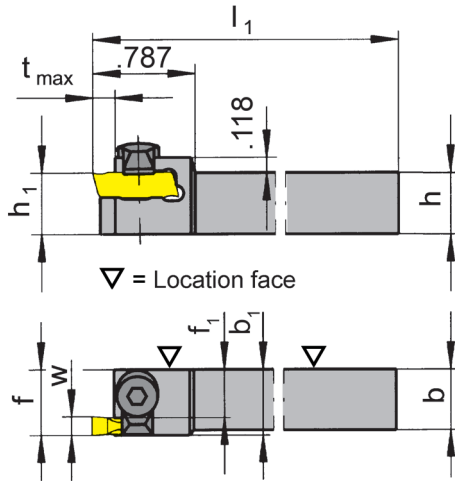

R = right hand version shown

L = left hand version

Part number	h	b	l_1	h_1	b_1	f_1	f	t_{max}	Size	Clamping range
R/LU240.0375.01	.375	.375	3.150	.375	.512	.453	f_1+w-a_1	.157	01	.020 - .067
R/LU240.0500.01	.500	.500	3.937	.500	.512	.453	f_1+w-a_1	.157	01	.020 - .067
R/LU240.0625.01	.625	.625	4.921	.625	.625	.566	f_1+w-a_1	.157	01	.020 - .067
R/LU240.0750.01	.750	.750	4.921	.750	.750	.691	f_1+w-a_1	.157	01	.020 - .067
R/LU240.1000.01	1.000	1.000	5.906	1.000	1.000	.941	f_1+w-a_1	.157	01	.020 - .067
R/LU240.0375.02	.375	.375	3.150	.375	.512	.413	f_1+w-a_1	.157	02	.067 - .106
R/LU240.0500.02	.500	.500	3.937	.500	.512	.413	f_1+w-a_1	.157	02	.067 - .106
R/LU240.0625.02	.625	.625	4.921	.625	.625	.527	f_1+w-a_1	.157	02	.067 - .106
R/LU240.0750.02	.750	.750	4.921	.750	.750	.652	f_1+w-a_1	.157	02	.067 - .106
R/LU240.1000.02	1.000	1.000	5.906	1.000	1.000	.902	f_1+w-a_1	.157	02	.067 - .106

State R or L version

w, a_1 see indexable inserts

Dimensions in inch

Further sizes upon request

For torque specification of the screw, please see Technical Instructions.

Spare Parts

Toolholder	Allen wrench	Clamping element
R/LU240...	SW2,5 DIN911	8.3



Grooving (external)



Toolholder

240

Depth of groove up to
Clamping range

4 mm
0.5 - 2.7 mm

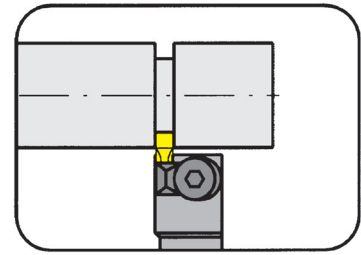

for Indexable insert

Type 217
U217

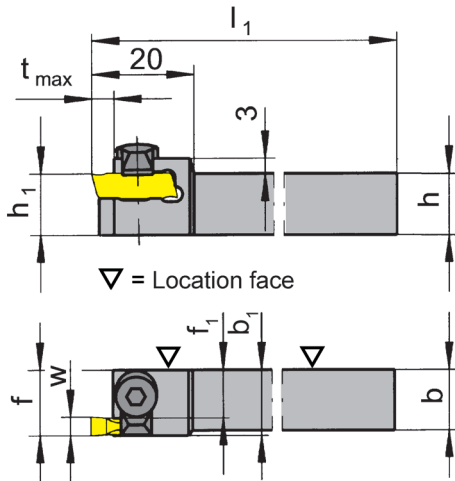

R = right hand version shown

L = left hand version

Part number	h	b	l_1	h_1	b_1	f_1	f	t_{max}	Size	Clamping range
R/L240.1010.01	10	10	80	10	13	11.5	f_1+w-a_1	4	01	0.5 - 1.7
R/L240.1212.01	12	12	100	12	13	11.5	f_1+w-a_1	4	01	0.5 - 1.7
R/L240.1414.01	14	14	100	14	14	12.5	f_1+w-a_1	4	01	0.5 - 1.7
R/L240.1616.01	16	16	125	16	16	14.5	f_1+w-a_1	4	01	0.5 - 1.7
R/L240.2020.01	20	20	125	20	20	18.5	f_1+w-a_1	4	01	0.5 - 1.7
R/L240.1010.02	10	10	80	10	13	10.5	f_1+w-a_1	4	02	1.7 - 2.7
R/L240.1212.02	12	12	100	12	13	10.5	f_1+w-a_1	4	02	1.7 - 2.7
R/L240.1414.02	14	14	100	14	14	11.5	f_1+w-a_1	4	02	1.7 - 2.7
R/L240.1616.02	16	16	125	16	16	13.5	f_1+w-a_1	4	02	1.7 - 2.7
R/L240.2020.02	20	20	125	20	20	17.5	f_1+w-a_1	4	02	1.7 - 2.7

State R or L version

w, a_1 see indexable inserts

Dimensions in mm

Further sizes upon request

For torque specification of the screw, please see Technical Instructions.

Spare Parts

Toolholder	Allen wrench	Clamping element
R/L240...	SW2,5 DIN911	8.3

Grooving (external)



Toolholder

U240

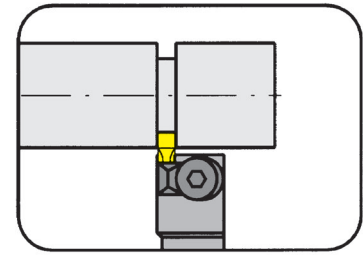

Depth of groove up to $.157''$
Clamping range $.106 - .209''$

for Indexable insert

Type 217
U217

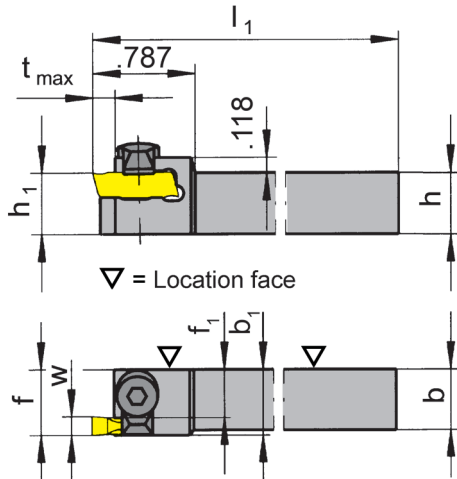

R = right hand version shown

L = left hand version

Part number	h	b	l_1	h_1	b_1	f_1	f	t_{max}	Size	Clamping range
R/LU240.0375.03	.375	.375	3.150	.375	.512	.374	f_1+w-a_1	.157	03	.106 - .146
R/LU240.0500.03	.500	.500	3.937	.500	.512	.374	f_1+w-a_1	.157	03	.106 - .146
R/LU240.0625.03	.625	.625	4.921	.625	.625	.487	f_1+w-a_1	.157	03	.106 - .146
R/LU240.0750.03	.750	.750	4.921	.750	.750	.612	f_1+w-a_1	.157	03	.106 - .146
R/LU240.1000.03	1.000	1.000	5.906	1.000	1.000	.862	f_1+w-a_1	.157	03	.106 - .146
R/LU240.0375.04	.375	.375	3.000	.375	.591	.386	f_1+w-a_1	.157	04	.146 - .209
R/LU240.0500.04	.500	.500	3.937	.500	.500	.386	f_1+w-a_1	.157	04	.146 - .209
R/LU240.0625.04	.625	.625	4.921	.625	.625	.420	f_1+w-a_1	.157	04	.146 - .209
R/LU240.0750.04	.750	.750	4.921	.750	.750	.545	f_1+w-a_1	.157	04	.146 - .209
R/LU240.1000.04	1.000	1.000	5.906	1.000	1.000	.795	f_1+w-a_1	.157	04	.146 - .209

State R or L version

w, a_1 see indexable inserts

Dimensions in inch

Further sizes upon request

For torque specification of the screw, please see Technical Instructions.

Spare Parts

Toolholder	Allen wrench	Clamping element
R/LU240...03	SW2,5 DIN911	8.3
R/LU240...04	SW2,5 DIN911	8.4



Grooving (external)



Toolholder

240

Depth of groove up to 4 mm
Clamping range 2.7 - 5.3 mm

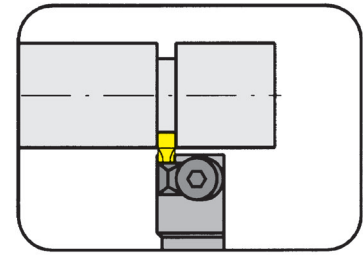

for Indexable insert

Type 217
U217

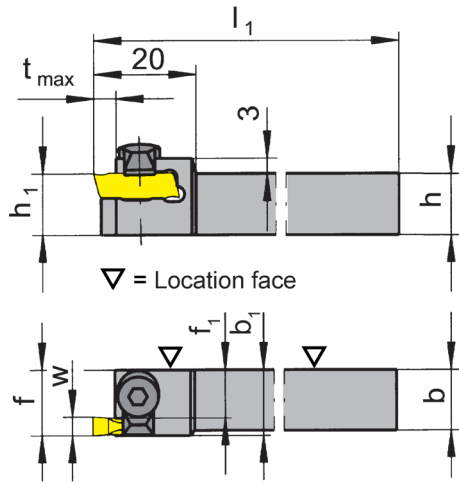

R = right hand version shown

L = left hand version

Part number	h	b	l ₁	h ₁	b ₁	f ₁	f	t _{max}	Size	Clamping range
R/L240.1010.03	10	10	80	10	13	9.5	f ₁ +w-a ₁	4	03	2.7 - 3.7
R/L240.1212.03	12	12	100	12	13	9.5	f ₁ +w-a ₁	4	03	2.7 - 3.7
R/L240.1414.03	14	14	100	14	14	10.5	f ₁ +w-a ₁	4	03	2.7 - 3.7
R/L240.1616.03	16	16	125	16	16	12.5	f ₁ +w-a ₁	4	03	2.7 - 3.7
R/L240.2020.03	20	20	125	20	20	16.5	f ₁ +w-a ₁	4	03	2.7 - 3.7
R/L240.1010.04	10	10	80	10	15	9.8	f ₁ +w-a ₁	4	04	3.7 - 5.3
R/L240.1212.04	12	12	100	12	15	9.8	f ₁ +w-a ₁	4	04	3.7 - 5.3
R/L240.1414.04	14	14	100	14	15	9.8	f ₁ +w-a ₁	4	04	3.7 - 5.3
R/L240.1616.04	16	16	125	16	16	10.8	f ₁ +w-a ₁	4	04	3.7 - 5.3
R/L240.2020.04	20	20	125	20	20	14.8	f ₁ +w-a ₁	4	04	3.7 - 5.3

State R or L version

w, a₁ see indexable inserts

Dimensions in mm

Further sizes upon request

For torque specification of the screw, please see Technical Instructions.

Spare Parts

Toolholder	Allen wrench	Clamping element
R/L240...03	SW2,5 DIN911	8.3
R/L240...04	SW2,5 DIN911	8.4

Grooving (external)



Toolholder

U248

Depth of groove up to .157"
Clamping range .035 - .106"

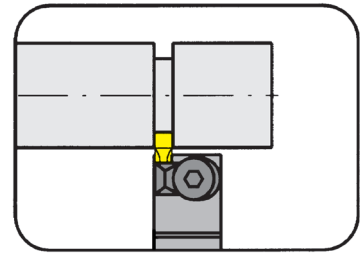

for Indexable insert

Type 217
U217

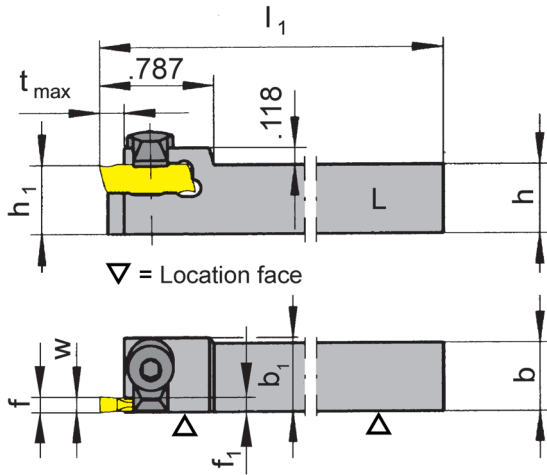

R = right hand version shown

L = left hand version

Part number	h	b	l ₁	h ₁	b ₁	f ₁	f	t _{max}	Size	Clamping range
R/LU248.0500.01	.500	.500	3.740	.500	.539	.480	f ₁ +a ₁	.157	01	.035 - .067
R/LU248.0500.02	.500	.500	3.740	.500	.539	.445	f ₁ +a ₁	.157	02	.067 - .106

State R or L version

w, a₁ see indexable inserts

Dimensions in inch

Further sizes upon request

For torque specification of the screw, please see Technical Instructions.

Spare Parts

Toolholder	Allen wrench	Clamping element
R/LU248...	SW2,5 DIN911	8.3



Grooving (external)



Toolholder

248

Depth of groove up to
Clamping range

4 mm
0.5 - 2.7 mm

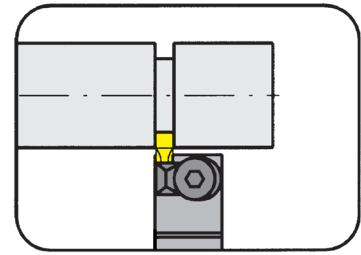

for Indexable insert

Type 217
U217

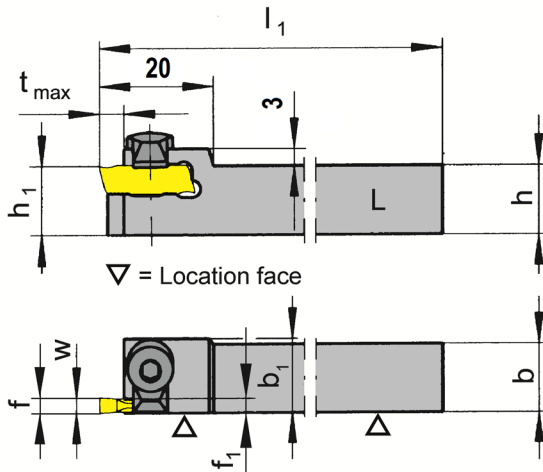

R = right hand version shown

L = left hand version

Part number	h	b	l_1	h_1	b_1	f_1	f	t_{max}	Size	Clamping range
R/L248.1212.01	12	12	95	12	13	1.5	f_1+a_1	4	01	0.5 - 1.7
R/L248.1212.02	12	12	95	12	13	2.5	f_1+a_1	4	02	1.7 - 2.7

State R or L version

w, a_1 see indexable inserts

Dimensions in mm

Further sizes upon request

For torque specification of the screw, please see Technical Instructions.

Spare Parts

Toolholder	Allen wrench	Clamping element
R/L248...	SW2,5 DIN911	8.3

F8

Call Us Toll Free (888) 818-4676

F

Grooving (internal)



Toolholder

U230/U250

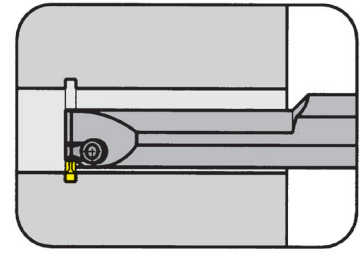

Bore Ø from
Depth of groove up to
Clamping range

.787"
.185"
.209"

for Indexable insert

Type 217
U217

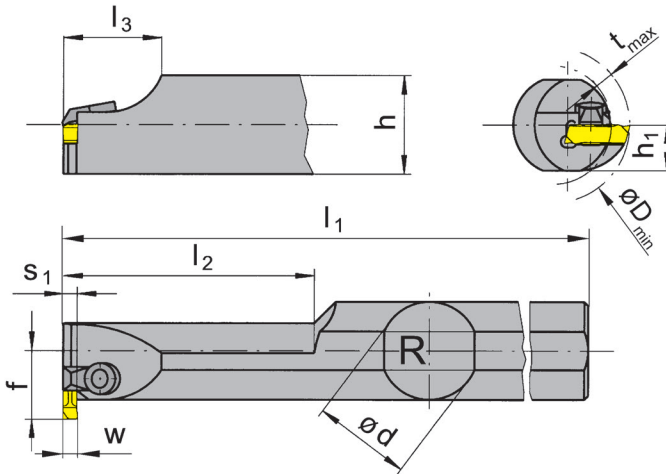

R = right hand version shown

L = left hand version

long style

F

Part number	d	l ₁	h ₁	t _{max}	l ₂	D _{min}	s ₁	l ₃	Size	Clamping range
R/LU230.0750.01	.750	7.008	.336	.118	2.362	.787	.059	.750	01	.035 - .067
R/LU250.1000.01	1.000	10.000	.461	.185	3.150	.984	.059	1.000	01	.035 - .067
R/LU250.1250.01	1.250	10.000	.586	.185	3.150	1.260	.059	1.000	01	.035 - .067
R/LU230.0750.02	.750	7.008	.336	.118	2.362	.787	.098	.750	02	.067 - .106
R/LU250.1000.02	1.000	10.000	.461	.185	3.150	.984	.098	1.000	02	.067 - .106
R/LU250.1250.02	1.250	10.000	.586	.185	3.150	1.260	.098	1.000	02	.067 - .106
R/LU230.0750.03	.750	7.008	.336	.118	2.362	.787	.138	.750	03	.106 - .146
R/LU250.1000.03	1.000	10.000	.461	.185	3.150	.984	.138	1.000	03	.106 - .146
R/LU250.1250.03	1.250	10.000	.586	.185	3.150	1.260	.138	1.000	03	.106 - .146
R/LU230.0750.04	.750	7.008	.336	.118	2.362	.787	.205	.750	04	.146 - .209
R/LU250.1000.04	1.000	10.000	.461	.185	3.150	.984	.205	1.000	04	.146 - .209
R/LU250.1250.04	1.250	10.000	.586	.185	3.150	1.260	.205	1.000	04	.146 - .209

State R or L version

w see indexable inserts

Dimensions in inch

Further sizes upon request

For torque specification of the screw, please see Technical Instructions.

Spare Parts

Toolholder	Allen wrench	Clamping element
R/LU2...01/.02/.03	SW2,5 DIN911	8.3
R/LU2...04	SW2,5 DIN911	8.4

Grooving (internal)



Toolholder

230/250

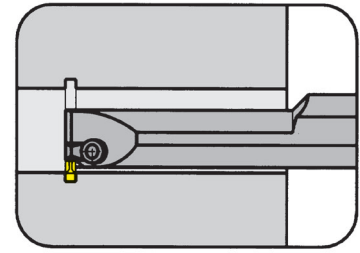

Bore Ø from	20 mm
Depth of groove up to	4.7 mm
Clamping range	0.9 - 5.3 mm

for Indexable insert

Type 217
U217

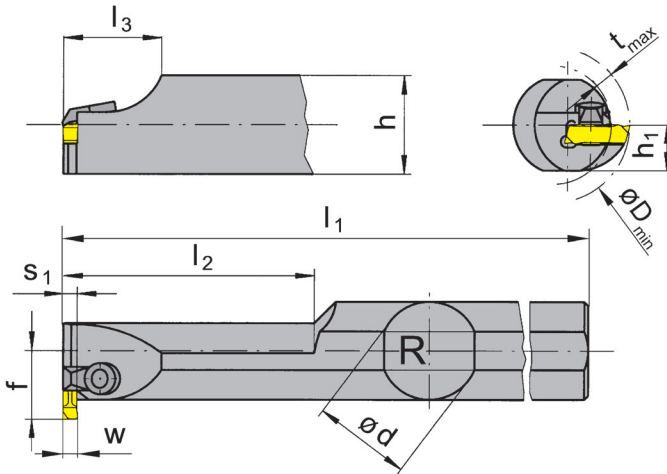

R = right hand version shown

L = left hand version

long style

Part number	d	l ₁	l ₂	l ₃	h	s ₁	h ₁	f	t _{max}	D _{min}	Size	Clamping range
R/L230.0020.01	20	180	60	18	18	1.5	9.0	13.3	2.0	20	01	0.9 - 1.7
R/L250.0025.01	25	250	80	25	23	1.5	11.5	17.5	4.7	25	01	0.9 - 1.7
R/L250.0032.01	32	250	80	25	30	1.5	15.0	21.0	4.7	32	01	0.9 - 1.7
R/L230.0020.02	20	180	60	18	18	2.5	9.0	13.3	2.0	20	02	1.7 - 2.7
R/L250.0025.02	25	250	80	25	23	2.5	11.5	17.5	4.7	25	02	1.7 - 2.7
R/L250.0032.02	32	250	80	25	30	2.5	15.0	21.0	4.7	32	02	1.7 - 2.7
R/L230.0020.03	20	180	60	18	18	3.5	9.0	13.3	2.0	20	03	2.7 - 3.7
R/L250.0025.03	25	250	80	25	23	3.5	11.5	17.5	4.7	25	03	2.7 - 3.7
R/L250.0032.03	32	250	80	25	30	3.5	15.0	21.0	4.7	32	03	2.7 - 3.7
R/L230.0020.04	20	180	60	18	18	5.2	9.0	13.3	3.0	20	04	3.7 - 5.3
R/L250.0025.04	25	250	80	25	23	5.2	11.5	17.5	4.7	25	04	3.7 - 5.3
R/L250.0032.04	32	250	80	25	30	5.2	15.0	21.0	4.7	32	04	3.7 - 5.3

State R or L version

w see indexable inserts

Dimensions in mm

Further sizes upon request

For torque specification of the screw, please see Technical Instructions.

Spare Parts

Toolholder	Allen wrench	Clamping element
R/L2...01/02/03	SW2,5 DIN911	8.3
R/L2...04	SW2,5 DIN911	8.4

Grooving (internal)



Toolholder

U233/U253

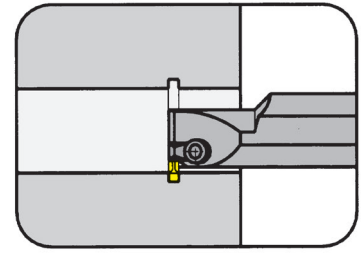

Bore Ø from .787"
 Depth of groove up to .185"
 Clamping range .035 - .209"

for Indexable insert

Type 217
 U217

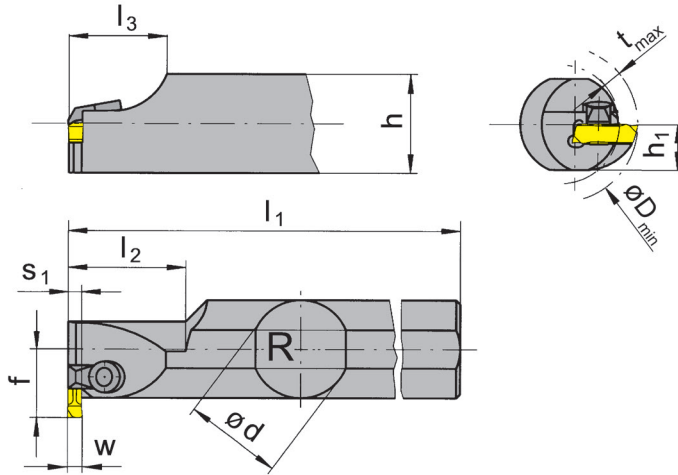

R = right hand version shown

L = left hand version

short style



Part number	d	l ₁	l ₂	l ₃	h	s ₁	h ₁	f	t _{max}	D _{min}	Size	Clamping range
R/LU233.0750.01	.750	5.000	.984	.750	.672	.059	.336	.505	.118	.787	01	.035 - .067
R/LU253.1000.01	1.000	5.984	1.181	1.000	.921	.059	.461	.697	.185	.984	01	.035 - .067
R/LU253.1250.01	1.250	5.984	1.181	1.000	1.171	.059	.586	.822	.185	1.260	01	.035 - .067
R/LU233.0750.02	.750	5.000	.984	.750	.672	.098	.336	.505	.118	.787	02	.067 - .106
R/LU253.1000.02	1.000	5.984	1.181	1.000	.921	.098	.461	.697	.185	.984	02	.067 - .106
R/LU253.1250.02	1.250	5.984	1.181	1.000	1.171	.098	.586	.822	.185	1.260	02	.067 - .106
R/LU233.0750.03	.750	5.000	.984	.750	.672	.138	.336	.505	.118	.787	03	.106 - .146
R/LU253.1000.03	1.000	5.984	1.181	1.000	.921	.138	.461	.697	.185	.984	03	.106 - .146
R/LU253.1250.03	1.250	5.984	1.181	1.000	1.171	.138	.586	.822	.185	1.260	03	.106 - .146
R/LU233.0750.04	.750	5.000	.984	.750	.672	.205	.336	.505	.118	.787	04	.146 - .209
R/LU253.1000.04	1.000	5.984	1.181	1.000	.921	.205	.461	.697	.185	.984	04	.146 - .209
R/LU253.1250.04	1.250	5.984	1.181	1.000	1.171	.205	.586	.822	.185	1.260	04	.146 - .209

State R or L version

w see indexable inserts

Dimensions in inch

Further sizes upon request

For torque specification of the screw, please see Technical Instructions.

Spare Parts

Toolholder	Allen wrench	Clamping element
R/LU2...01/.02/.03	SW2,5 DIN911	8.3
R/LU2...04	SW2,5 DIN911	8.4

Toolholder

233/253

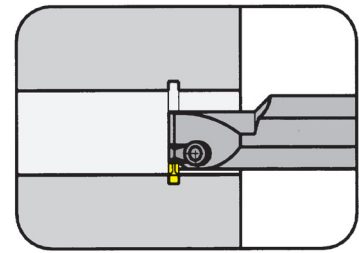

Bore \varnothing from 20 mm
 Depth of groove up to 4.7 mm
 Clamping range 0.9 - 5.3 mm

for Indexable insert

Type 217
 U217

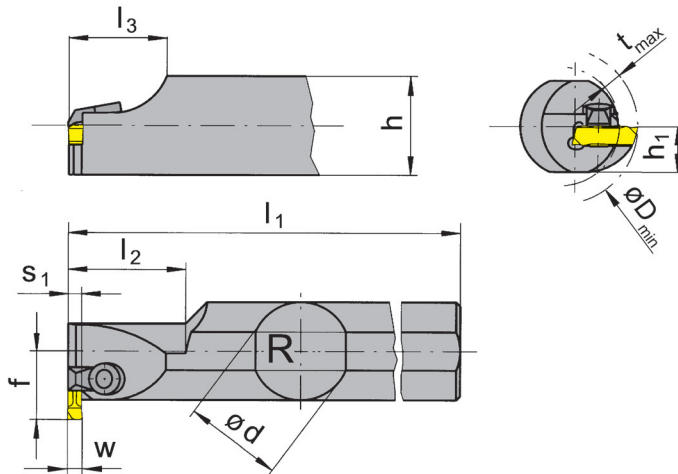

R = right hand version shown

L = left hand version

short style

Part number	d	l ₁	l ₂	l ₃	h	s ₁	h ₁	f	t _{max}	D _{min}	Size	Clamping range
R/L233.0020.01	20	130	25	18	18	1.5	9.0	13.3	2.0	20	01	0.9 - 1.7
R/L253.0025.01	25	150	30	25	23	1.5	11.5	17.5	4.7	25	01	0.9 - 1.7
R/L253.0032.01	32	150	30	25	30	1.5	15.0	21.0	4.7	32	01	0.9 - 1.7
R/L233.0020.02	20	130	25	18	18	2.5	9.0	13.3	2.0	20	02	1.7 - 2.7
R/L253.0025.02	25	150	30	25	23	2.5	11.5	17.5	4.7	25	02	1.7 - 2.7
R/L253.0032.02	32	150	30	25	30	2.5	15.0	21.0	4.7	32	02	1.7 - 2.7
R/L233.0020.03	20	130	25	18	18	3.5	9.0	13.3	2.0	20	03	2.7 - 3.7
R/L253.0025.03	25	150	30	25	23	3.5	11.5	17.5	4.7	25	03	2.7 - 3.7
R/L253.0032.03	32	150	30	25	30	3.5	15.0	21.0	4.7	32	03	2.7 - 3.7
R/L233.0020.04	20	130	25	18	18	5.2	9.0	13.3	3.0	20	04	3.7 - 5.3
R/L253.0025.04	25	150	30	25	23	5.2	11.5	17.5	4.7	25	04	3.7 - 5.3
R/L253.0032.04	32	150	30	25	30	5.2	15.0	21.0	4.7	32	04	3.7 - 5.3

State R or L version

w see indexable inserts

Dimensions in mm

Further sizes upon request

For torque specification of the screw, please see Technical Instructions.

Spare Parts

Toolholder	Allen wrench	Clamping element
R/L2...01/02/03	SW2,5 DIN911	8.3
R/L2...04	SW2,5 DIN911	8.4

Grooving (internal)



Toolholder

U254

Bore Ø from .984"
 Depth of groove up to .185"
 Clamping range .035 - .209"

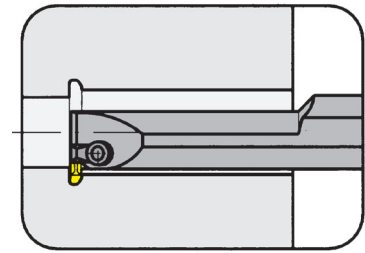

for Indexable insert

Type 217
 U217

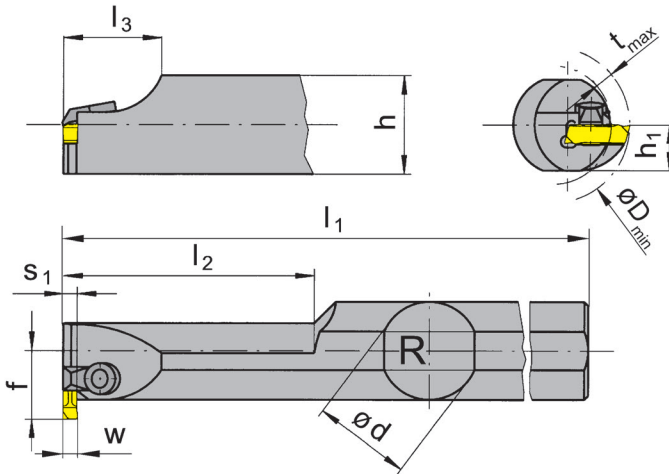

R = right hand version shown

L = left hand version

long reach for special insert shapes

Part number	d	l ₁	l ₂	l ₃	h	s ₁	h ₁	f	t _{max}	D _{min}	Size	Clamping range
R/LU254.1000.01	1.000	10.000	3.150	1.000	.921	.059	.461	.697	.185	.984	01	.035 - .067
R/LU254.1250.01	1.250	10.000	3.150	1.000	1.171	.059	.586	.822	.185	1.260	01	.035 - .067
R/LU254.1000.02	1.000	10.000	3.150	1.000	.921	.098	.461	.697	.185	.984	02	.067 - .106
R/LU254.1250.02	1.250	10.000	3.150	1.000	1.171	.098	.586	.822	.185	1.260	02	.067 - .106
R/LU254.1000.03	1.000	10.000	3.150	1.000	.921	.138	.461	.697	.185	.984	03	.106 - .146
R/LU254.1250.03	1.250	10.000	3.150	1.000	1.171	.138	.586	.822	.185	1.260	03	.106 - .146
R/LU254.1000.04	1.000	10.000	3.150	1.000	.921	.205	.461	.697	.185	.984	04	.146 - .209
R/LU254.1250.04	1.250	10.000	3.150	1.000	1.171	.205	.586	.822	.185	1.260	04	.146 - .209

State R or L version

w see indexable inserts

Dimensions in inch

Further sizes upon request

For torque specification of the screw, please see Technical Instructions.

Spare Parts

Toolholder	Allen wrench	Clamping element
R/LU254...01/.02/.03	SW2,5 DIN911	8.3
R/LU254...04	SW2,5 DIN911	8.4

Grooving (internal)



Toolholder

234/254

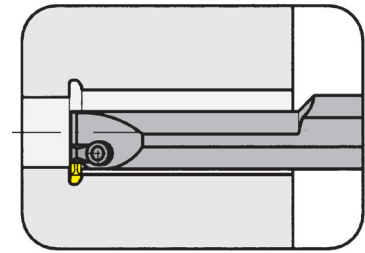

Bore \varnothing from
Depth of groove up to
Clamping range

20 mm
4.7 mm
0.9 - 5.3 mm

for Indexable insert

Type 217
U217



long reach for special
insert shapes

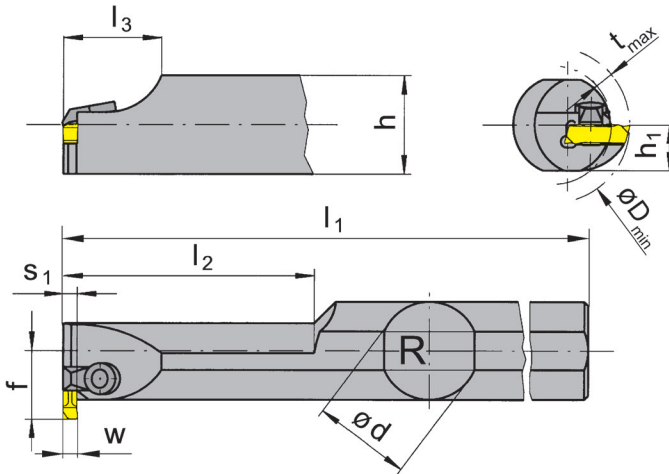

R = right hand version shown

L = left hand version

Part number	d	l ₁	l ₂	l ₃	h	s ₁	h ₁	f	t _{max}	D _{min}	Size	Clamping range
R/L234.0020.01	20	180	60	18	18	1.5	9.0	13.3	2.0	20	01	0.9 - 1.7
R/L254.0025.01	25	250	80	25	23	1.5	11.5	17.5	4.7	25	01	0.9 - 1.7
R/L254.0032.01	32	250	80	25	30	1.5	15.0	21.0	4.7	32	01	0.9 - 1.7
R/L234.0020.02	20	180	60	18	18	2.5	9.0	13.3	2.0	20	02	1.7 - 2.7
R/L254.0025.02	25	250	80	25	23	2.5	11.5	17.5	4.7	25	02	1.7 - 2.7
R/L254.0032.02	32	250	80	25	30	2.5	15.0	21.0	4.7	32	02	1.7 - 2.7
R/L234.0020.03	20	180	60	18	18	3.5	9.0	13.3	2.0	20	03	2.7 - 3.7
R/L254.0025.03	25	250	80	25	23	3.5	11.5	17.5	4.7	25	03	2.7 - 3.7
R/L254.0032.03	32	250	80	25	30	3.5	15.0	21.0	4.7	32	03	2.7 - 3.7
R/L234.0020.04	20	180	60	18	18	5.2	9.0	13.3	3.0	20	04	3.7 - 5.3
R/L254.0025.04	25	250	80	25	23	5.2	11.5	17.5	4.7	25	04	3.7 - 5.3
R/L254.0032.04	32	250	80	25	30	5.2	15.0	21.0	4.7	32	04	3.7 - 5.3

State R or L version

w see indexable inserts

Dimensions in mm

Further sizes upon request

For torque specification of the screw, please see Technical Instructions.

Spare Parts

Toolholder	Allen wrench	Clamping element
R/L2...01/02/03	SW2,5 DIN911	8.3
R/L2...04	SW2,5 DIN911	8.4

Grooving (internal)



Toolholder

U235/U255

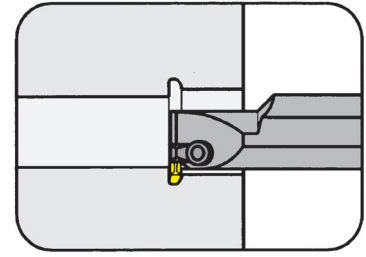

Bore Ø from
Depth of groove up to
Clamping range

.787"
.185"
.035 - .209"

for Indexable insert

Type 217
U217

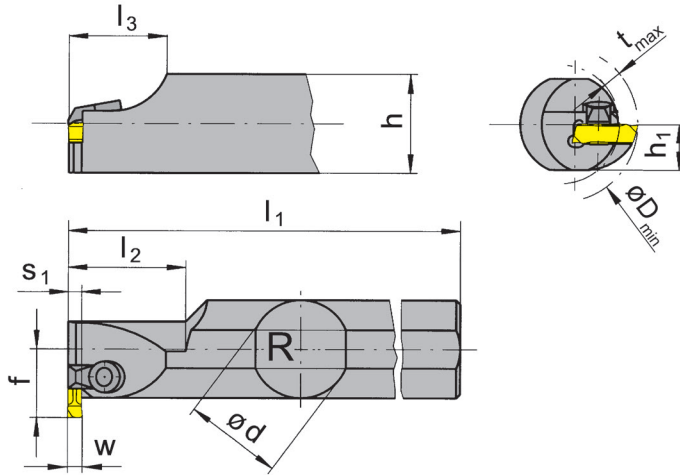

R = right hand version shown

L = left hand version

short reach for special
insert shapes

F

Part number	d	l ₁	l ₂	l ₃	h	s ₁	h ₁	f	t _{max}	D _{min}	Size	Clamping range
R/LU235.0750.01	.750	5.000	.984	.750	.672	.059	.336	.505	.118	.787	01	.035 - .067
R/LU255.1000.01	1.000	5.984	1.181	1.000	.921	.059	.461	.697	.185	.984	01	.035 - .067
R/LU255.1250.01	1.250	5.984	1.181	1.000	1.181	.059	.591	.822	.185	1.260	01	.035 - .067
R/LU235.0750.02	.750	5.000	.984	.750	.672	.098	.336	.505	.118	.787	02	.067 - .106
R/LU255.1000.02	1.000	5.984	1.181	1.000	.922	.098	.461	.697	.185	.984	02	.067 - .106
R/LU255.1250.02	1.250	5.984	1.181	1.000	1.172	.098	.586	.822	.185	1.260	02	.067 - .106
R/LU235.0750.03	.750	5.000	.984	.750	.672	.138	.336	.505	.118	.787	03	.106 - .146
R/LU255.1000.03	1.000	5.984	1.181	1.000	.921	.138	.461	.697	.185	.984	03	.106 - .146
R/LU255.1250.03	1.250	5.984	1.181	1.000	1.172	.138	.586	.822	.185	1.260	03	.106 - .146
R/LU235.0750.04	.750	5.000	.984	.750	.672	.205	.336	.505	.118	.787	04	.146 - .209
R/LU255.1000.04	1.000	5.984	1.181	1.000	.922	.205	.461	.697	.185	.984	04	.146 - .209
R/LU255.1250.04	1.250	5.984	1.181	1.000	1.172	.205	.586	.822	.185	1.260	04	.146 - .209

State R or L version

w see indexable inserts

Dimensions in inch

Further sizes upon request

For torque specification of the screw, please see Technical Instructions.

Spare Parts

Toolholder	Allen wrench	Clamping element
R/LU2...01/.02/.03	SW2,5 DIN911	8.3
R/LU2...04	SW2,5 DIN911	8.4

Grooving (internal)



Toolholder

235/255

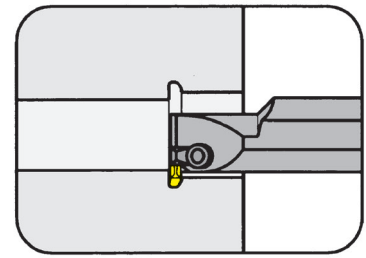

Bore \varnothing from
Depth of groove up to
Clamping range

20 mm
4.7 mm
0.9 - 5.3 mm

for Indexable insert

Type 217
U217



short reach for special
insert shapes

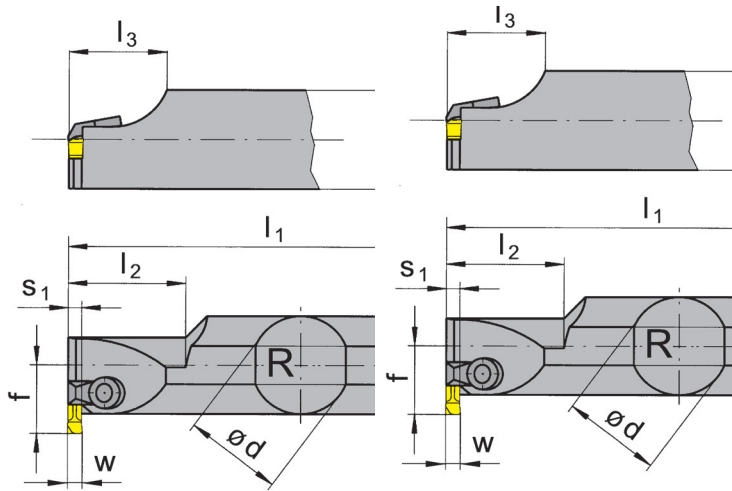

R = right hand version shown

L = left hand version

Part number	d	l ₁	l ₂	l ₃	h	s ₁	h ₁	f	t _{max}	D _{min}	Size	Clamping range
R/L235.0020.01	20	130	25	18	18	1.5	9.0	13.3	2.0	20	01	0.9 - 1.7
R/L255.0025.01	25	150	30	25	23	1.5	11.5	17.5	4.7	25	01	0.9 - 1.7
R/L255.0032.01	32	150	30	25	30	1.5	15.0	21.0	4.7	32	01	0.9 - 1.7
R/L235.0020.02	20	130	25	18	18	2.5	9.0	13.3	2.0	20	02	1.7 - 2.7
R/L255.0025.02	25	150	30	25	23	2.5	11.5	17.5	4.7	25	02	1.7 - 2.7
R/L255.0032.02	32	150	30	25	30	2.5	15.0	21.0	4.7	32	02	1.7 - 2.7
R/L235.0020.03	20	130	25	18	18	3.5	9.0	13.3	2.0	20	03	2.7 - 3.7
R/L255.0025.03	25	150	30	25	23	3.5	11.5	17.5	4.7	25	03	2.7 - 3.7
R/L255.0032.03	32	150	30	25	30	3.5	15.0	21.0	4.7	32	03	2.7 - 3.7
R/L235.0020.04	20	130	25	18	18	5.2	9.0	13.3	3.0	20	04	3.7 - 5.3
R/L255.0025.04	25	150	30	25	23	5.2	11.5	17.5	4.7	25	04	3.7 - 5.3
R/L255.0032.04	32	150	30	25	30	5.2	15.0	21.0	4.7	32	04	3.7 - 5.3

State R or L version

w see indexable inserts

Dimensions in mm

Further sizes upon request

For torque specification of the screw, please see Technical Instructions.

Spare Parts

Toolholder	Allen wrench	Clamping element
R/L2...01/02/03	SW2,5 DIN911	8.3
R/L2...04	SW2,5 DIN911	8.4

Grooving Corner Reliefs (internal)



Toolholder

U245

Bore Ø from .787"

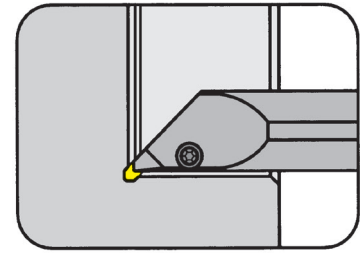

for Indexable insert

Type 217



similar to DIN 509 form "F"

F

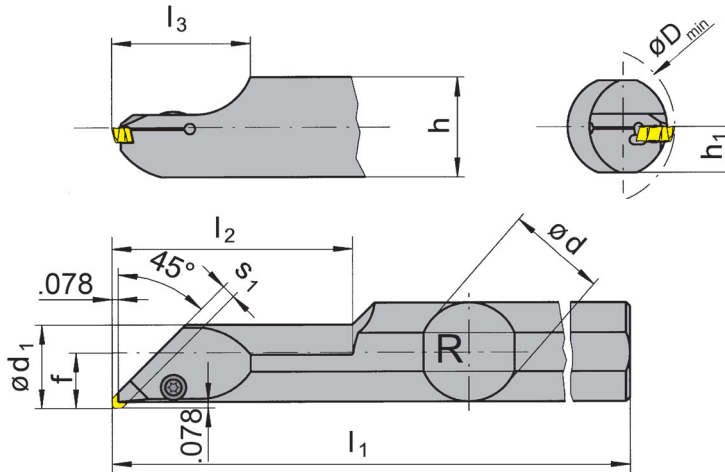

R = right hand version shown

L = left hand version

Part number	d	l ₂	h	l ₁	h ₁	f	D _{min}	d ₁	s ₁	l ₃	Size	Clamping range
R/LU245.0750.02	.750	2.359	.671	7.025	.336	.470	.787	.694	.098	1.402	02	.067 - .106
R/LU245.1250.02	1.250	3.285	1.171	10.017	.586	.726	1.220	1.142	.098	1.750	02	.067 - .106
RU245.1000.02	1.000	3.167	.921	10.017	.461	.596	.984	1.096	.098	1.750	02	.067 - .106
R/LU245.0750.03	.750	2.387	.671	7.033	.336	.478	.787	.706	.138	1.378	03	.106 - .146
R/LU245.1000.03	1.000	3.273	.921	10.025	.461	.604	.984	.880	.138	1.750	03	.106 - .146
R/LU245.1250.03	1.250	3.254	1.171	10.025	.586	.734	1.220	1.135	.138	1.750	03	.106 - .146
R/LU245.0750.04	.750	2.401	.672	7.047	.336	.493	.787	.716	.205	1.248	04	.146 - .209
R/LU245.1250.04	1.250	3.189	1.172	10.039	.586	.743	1.220	1.149	.205	1.656	04	.146 - .209
RU245.1000.04	1.000	3.287	.921	10.039	.461	.618	.984	.894	.205	1.750	04	.146 - .209

State R or L version

Dimensions in inch

Further sizes upon request

For torque specification of the screw, please see Technical Instructions.

Spare Parts

Toolholder	Clamping Screw	TORX PLUS® Wrench
R/LU245...	51.27.984P	T15PQ

Grooving Corner Reliefs (internal)



Toolholder

245

Bore Ø from 20 mm

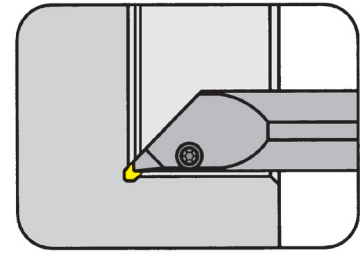

for Indexable insert

Type 217

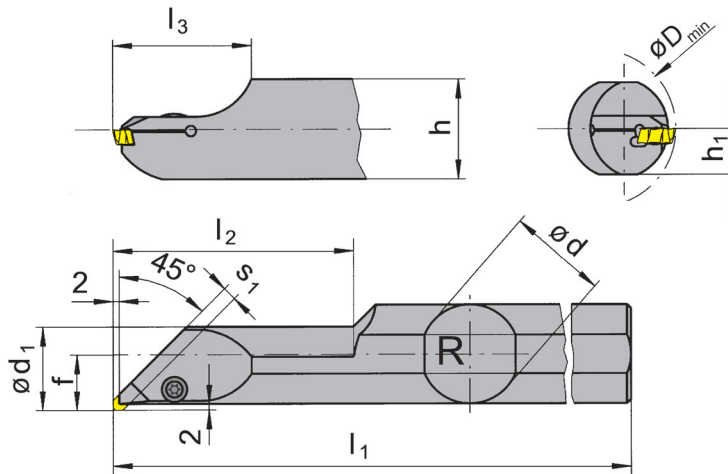

R = right hand version shown

L = left hand version



similar to DIN 509 form "F"

Part number	d	l ₂	h	l ₁	h ₁	f	D _{min}	d ₁	s ₁	l ₃	Size	Clamping range
R/L245.0020.02	20	60.43	18	180	9	12	20	17.2	2.5	35.60	02	1.7 - 2.7
R/L245.0032.02	32	80.00	30	250	15	18	31	28.2	2.5	41.60	02	1.7 - 2.7
R/L245.0020.03	20	60.00	18	180	9	12	20	17.2	3.5	35.00	03	2.7 - 3.7
R/L245.0032.03	32	80.64	30	250	15	18	31	28.2	3.5	41.82	03	2.7 - 3.7
R/L245.0020.04	20	60.99	18	180	9	12	20	17.2	5.2	36.17	04	3.7 - 5.3
R/L245.0032.04	32	80.99	30	250	15	18	31	28.2	5.2	42.17	04	3.7 - 5.3

State R or L version

Dimensions in mm

Further sizes upon request

For torque specification of the screw, please see Technical Instructions.

Spare Parts

Toolholder	Clamping Screw	TORX PLUS® Wrench
R/L245...	51.27.984P	T15PQ

Grooving (external and internal)



Indexable insert

U217

Circlip grooves
Width of groove

DIN 471/472
.026 - .188"

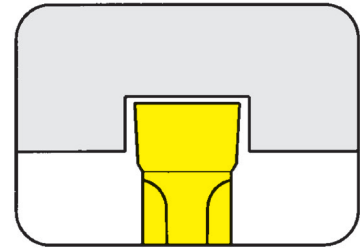

for Toolholder

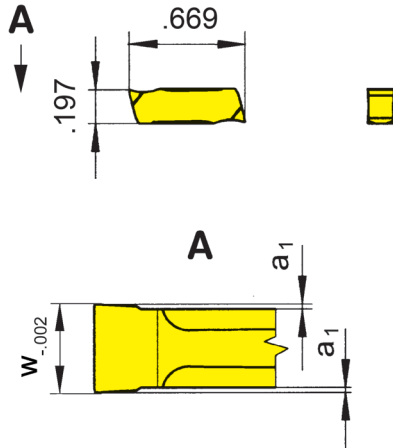

Type 240 / U240
248 / U248
232
230 / U230
233 / U233
250 / U250
253 / U253

Indexability length
± .0008"

Part number	w	a ₁	Size	Carbide grades						
				K10	MG12	P20	TF45	TF46	TN32	
U217.0026.00	.026	.002	01						▲	
U217.0031.00	.031	.002	01				▲	▲	▲	
U217.0034.00	.034	.002	01	Δ					Δ	
U217.0039.00	.039	.002	01						▲	
U217.0040.00	.040	.002	01			▲			▲	
U217.0046.00	.046	.004	01				▲	▲	▲	
U217.0056.00	.056	.004	01	▲					▲	
U217.0062.00	.062	.004	01	▲		▲	▲	▲	▲	
U217.0078.00	.078	.004	02	▲					▲	
U217.0094.00	.094	.004	02				▲	▲	▲	
U217.0125.00	.125	.004	03	▲	▲		▲	▲	▲	
U217.0157.00	.157	.004	04				▲		▲	
U217.0188.00	.188	.004	04						▲	
▲ on stock Δ 4 weeks x upon request				P	●	○	●	●	●	●
● recommended				M	○	-	-	●	○	-
○ alternative recommendation				K	●	-	-	●	●	-
- not suitable				N	●	-	-	●	●	-
■ uncoated grades				S	○	-	-	●	○	-
■ coated grades				H	-	-	-	-	-	-
■ brazed/Cermet										

Dimensions in inch

Carbide grades

Indexable inserts can be used in **right and left** hand toolholders.

Max. depth of groove can be reached only with width of cut ≥ .043"

Smaller inserts have a limited depth of groove t_{max} = .039" and deeper depths are depending on Ø of workpiece.

Grooving (external and internal)



Indexable insert

217

Circlip grooves
Width of circlip Nw

DIN 471/472
.020 - .203"

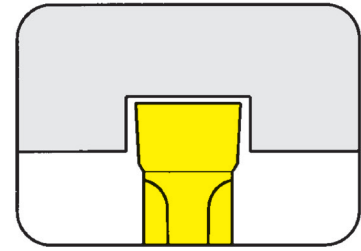

for Toolholder

- Type
- 240 / U240
 - 248 / U248
 - 232
 - 230 / U230
 - 233 / U233
 - 234 / U234
 - 235 / U235
 - 250 / U250
 - 253 / U253
 - 254 / U254
 - 255 / U255
 - 245 / U245

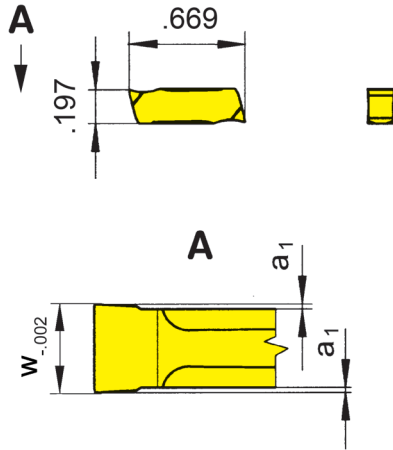

Indexability length
± .0008"

Part number	w	Nw	a ₁	Size	Carbide grades							
					K10	MG12	P20	TC92	TN32	TN35	H20	
217.0050.00	.022	.020	.002	01	▲		▲		▲			
217.0060.00	.026	.024	.002	01	▲		▲		▲			
217.0070.00	.030	.028	.002	01	▲		▲		▲			
217.0080.00	.034	.031	.002	01	▲		▲		▲			
217.0090.00	.038	.035	.002	01	▲		▲		▲			
217.0100.00	.042	.039	.002	01	▲		▲		▲			
217.0110.00	.049	.043	.004	01	▲		▲		▲			
217.0130.00	.057	.051	.004	01	▲		▲		▲			
217.0160.00	.069	.063	.004	01	▲		▲	▲	▲	▲		
217.0185.00	.078	.073	.004	02	▲	x	▲	▲	▲	▲	▲	
217.0215.00	.090	.085	.004	02	▲		▲	▲	▲	▲		
217.0265.00	.110	.104	.004	02	▲		▲	▲	▲	▲		
217.0315.00	.130	.124	.004	03	▲		▲	▲	▲	▲		
217.0415.00	.169	.163	.004	04	▲		▲	▲	▲	▲		
217.0515.00	.208	.203	.004	04	▲		▲	▲	▲	▲		
					P	•	•	•	•	•	•	•
					M	•	-	-	-	-	•	•
					K	•	-	-	-	-	•	-
					N	•	-	-	-	-	•	-
					S	•	-	-	-	-	•	-
					H	-	-	-	-	-	-	-

▲ on stock Δ 4 weeks x upon request
 ● recommended
 ○ alternative recommendation
 - not suitable
 ■ uncoated grades
 ■ coated grades
 ■ brazed/Cermet

Dimensions in inch

Carbide grades

Indexable inserts can be used in **right and left** hand toolholders.
Max. depth of groove can be reached only with width of cut ≥ .043"

Smaller inserts have a limited depth of groove $t_{max} = 1$ mm and deeper depths are depending on Ø of workpiece.

Indexable insert

217

Circlip grooves
Width of circlip Nw

DIN 471/472
.043 - .163"

with chamfer

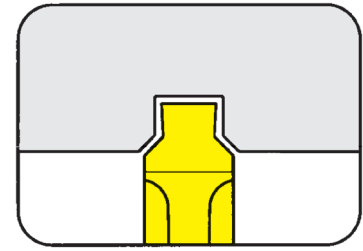

for Toolholder

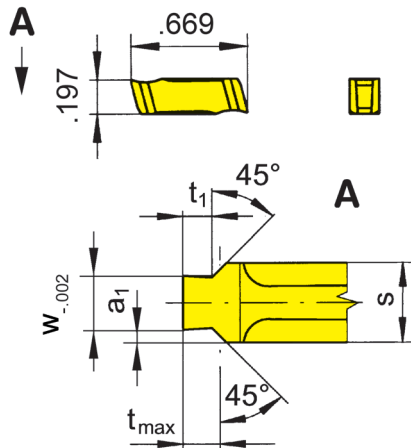

- Type
- 240 / U240
 - 248 / U248
 - 245 / U245
 - 232
 - 230 / U230
 - 233 / U233
 - 234 / U234
 - 235 / U235
 - 250 / U250
 - 253 / U253
 - 254 / U254
 - 255 / U255

for special dimensions
please state: w, t1, tmax

F

Part number	w	Nw	t _{max}	a ₁	s	t ₁	Size	MG12	P20	TN32
217.1101.25	.049	.043	.008	.025	.098	.007	02	x	x	
217.1102.25	.049	.043	.010	.025	.098	.009	02	x	x	
217.1103.25	.049	.043	.012	.025	.098	.011	02	x	x	
217.1104.25	.049	.043	.014	.025	.098	.013	02	x	x	
217.1105.25	.049	.043	.016	.025	.098	.014	02	x	x	
217.1306.25	.057	.051	.022	.021	.098	.018	02		x	▲
217.1607.33	.069	.063	.028	.031	.130	.024	03		x	▲
217.1608.33	.069	.063	.033	.031	.130	.030	03	x	x	
217.1609.33	.069	.063	.039	.031	.130	.033	03			▲
217.1810.33	.078	.073	.039	.026	.130	.033	03	x	x	
217.1812.33	.078	.073	.049	.026	.130	.043	03		▲	▲
217.2115.43	.090	.085	.059	.040	.169	.053	04		x	▲
217.2616.43	.110	.104	.059	.030	.169	.053	04			▲
217.2617.43	.110	.104	.069	.030	.169	.063	04			▲
217.3118.53	.130	.124	.069	.040	.209	.063	04			▲
217.4120.53	.169	.163	.079	.020	.209	.073	04			▲
217.4125.53	.169	.163	.098	.020	.209	.093	04	x	x	
								P	o	•
								M	-	-
								K	-	-
								N	-	-
								S	-	-
								H	-	-

▲ on stock Δ 4 weeks x upon request

- recommended
- o alternative recommendation
- not suitable

- uncoated grades
- coated grades
- brazed/Cermet

Dimensions in inch

Carbide grades

Indexable inserts can be used in **right and left** hand toolholders.

Indexable insert

217

Thread relief DIN 76 Short Form

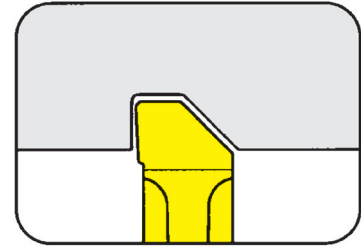

for Toolholder

- Type
- 240 / U240
 - 248 / U248
 - 234 / U234
 - 235 / U235
 - 254 / U254
 - 255 / U255

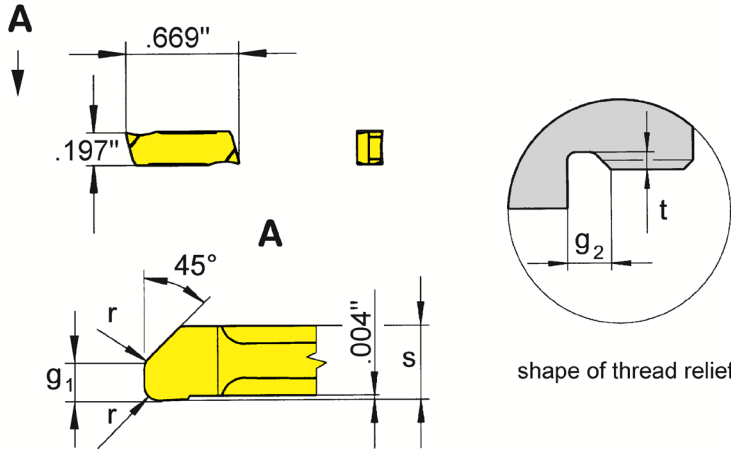

R = right hand version shown

L = left hand version

Part number	P	r	t ₁	s	g ₁	g ₂	Size	P20
R/L217.1050.17	.020	.008	.020	.067	.049	.069	01	x/x
R/L217.1060.27	.024	.016	.022	.106	.059	.081	02	Δ/Δ
R/L217.1070.27	.028	.016	.024	.106	.069	.093	02	x/x
R/L217.1080.27	.031	.016	.028	.106	.079	.106	02	x/x
R/L217.1100.37	.039	.024	.035	.146	.098	.134	03	▲/Δ
R/L217.1125.53	.049	.024	.041	.209	.126	.167	04	Δ/Δ
R/L217.1150.53	.059	.031	.047	.209	.150	.197	04	Δ/Δ

- ▲ on stock Δ 4 weeks x upon request
- recommended
- o alternative recommendation
- not suitable
- uncoated grades
- coated grades
- brazed/Cermet

P	•
M	-
K	-
N	-
S	-
H	-

Dimensions in inch

State R or L version

Carbide grades

External machining:

Use right hand inserts in right hand toolholders and left hand inserts in left hand toolholders

Internal machining:

Use right hand inserts in left hand toolholders and left hand inserts in right hand toolholders

Grooving Corner Reliefs (internal)



Indexable insert

217

Corner reliefs similar to DIN 509 form "F"

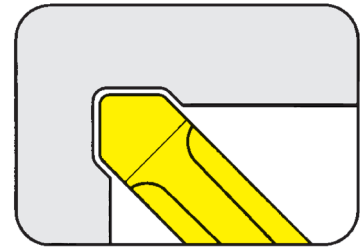

for Toolholder

Type 245 / U245

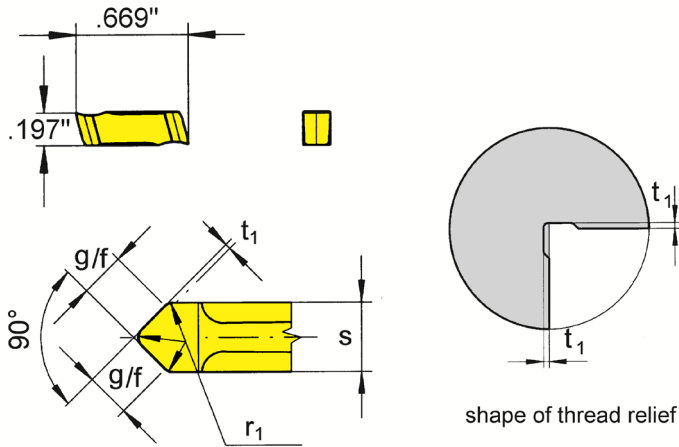

Part number	r_1	D_{min}	t_1	s	g/f	Size		P20	TN32
217.0602.24	.024	.787	.008	.094	.067	02	▲	▲	▲
217.0603.33	.024	.906	.012	.130	.091	03	▲		
217.1002.30	.039	.866	.008	.118	.083	03	x		
217.1004.50	.039	1.063	.016	.197	.142	04	x		
217.1603.50	.063	1.063	.012	.197	.142	04	x		
							P	•	•
							M	-	-
							K	-	-
							N	-	-
							S	-	-
							H	-	-

▲ on stock Δ 4 weeks x upon request

• recommended
o alternative recommendation

- not suitable

uncoated grades

coated grades

brazed/Cermet

Dimensions in inch

Carbide grades

Indexable inserts can be used in **right and left** hand toolholders.

Grooving Corner Reliefs (internal)



Indexable insert

217

Full radius .039 - .098"

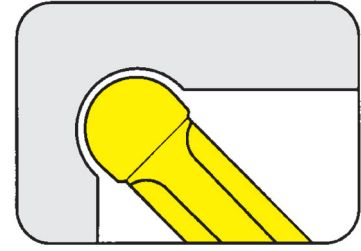

for Toolholder

Type 245 / U245

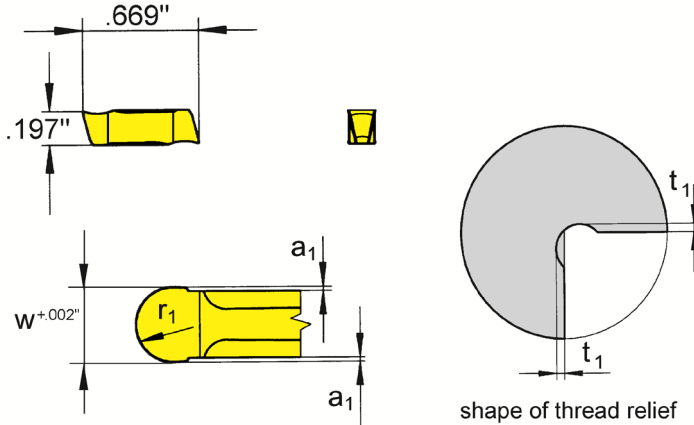

F

Part number	w	a ₁	D _{min}	t ₁	r ₁	Size	K10	P20	TC92	TF45	TI25	TN32	TN35
217.0010.20	.079	.004	.787	.030	.039	02	▲	▲	▲	x	x	▲	▲
217.0015.30	.118	.004	.787	.039	.059	03	▲	▲				▲	▲
217.0020.40	.157	.004	.787	.049	.079	04		▲					▲
217.0025.50	.197	.004	.787	.059	.098	04	▲	▲					
							P	•	•	•	•	•	•
							M	o	-	-	•	-	•
							K	•	-	-	•	-	•
							N	•	-	-	•	-	•
							S	o	-	-	•	-	•
							H	-	-	-	-	-	-

▲ on stock Δ 4 weeks x upon request
 • recommended
 o alternative recommendation
 - not suitable

■ uncoated grades
 ■ coated grades
 ■ brazed/Cermet

Dimensions in inch

Carbide grades

Indexable inserts can be used in **right and left** hand toolholders.

Cartridge

232

Bore Ø from 40 mm

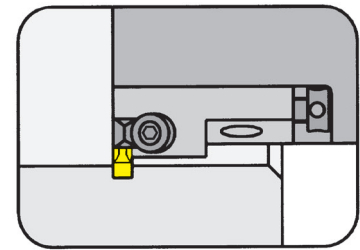

Indexable insert

Type 231
N231
312
217

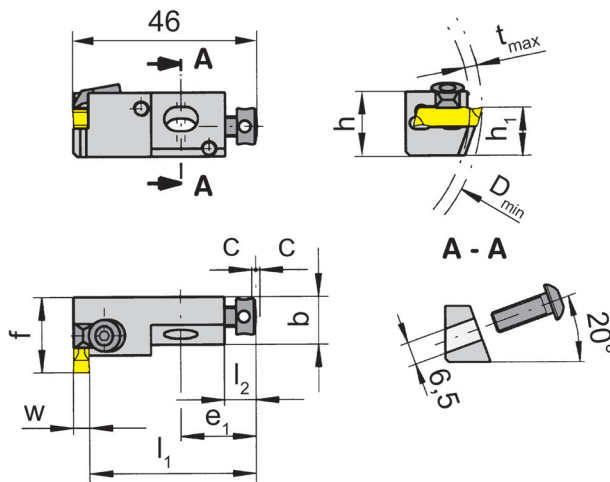

R = right hand version shown

L = left hand version

Part number	h	b	h ₁	f	l ₁	E ₁	l ₂	C	D _{min}	t _{max}	Size	Clamping range
R232.1212.01	16	12	12	19	44.4	19	8	1	40	3	01	0.9 - 1.7
R232.1212.02	16	12	12	19	43.4	19	8	1	40	3	02	1.7 - 2.7
R232.1212.03	16	12	12	19	42.4	19	8	1	40	3	03	2.7 - 3.7
R232.1212.04	16	12	12	19	40.7	19	8	1	40	3	04	3.7 - 5.3

Further sizes upon request

Dimensions in mm

Dimensions of seating see following page

For torque specification of the screw, please see Technical Instructions.

Spare Parts

Cartridge	Clamping Screw	Allen wrench	Screw	Clamping element	Setting screw
R232.1212....	4.08.913	SW2,5 DIN911	6.20.232	8.3	5.08.020
R232.1212.04	4.08.913	SW2,5 DIN911	6.20.232	8.4	5.08.020



Seating Dimension Cartridge

232

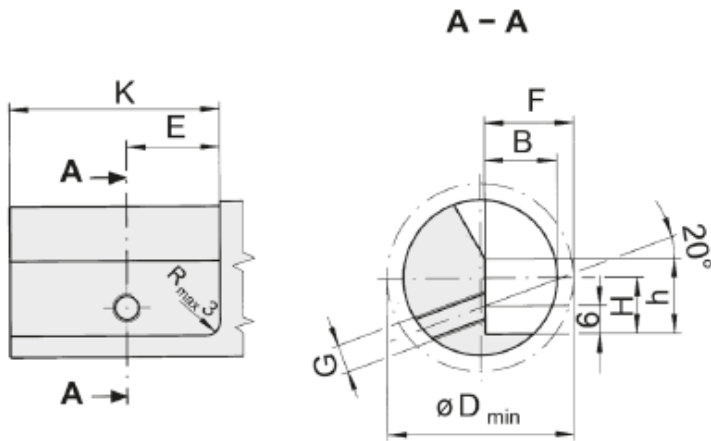
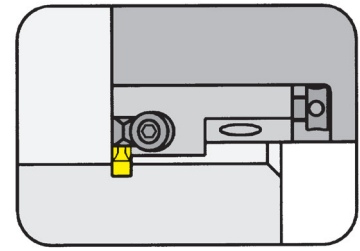

F

Part number	F	G	H	K	E	B	h	D _{min}	Fastening Screw
232.1212...	19	M6	12	45	20	15.5	16	40	6.20.232

Dimensions in mm

224



G

Toolholder with Inserts

Width of groove .079 - .236"

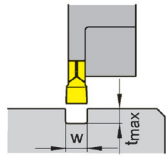

$w = .078 - .236"$
(2 - 6 mm)
 $t_{max} = .709"$
(18 mm)

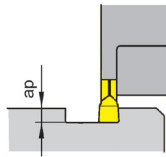

$w = .118 - .236"$
(3 - 6 mm)
 $a_{pmax} = .157"$
(4 mm)

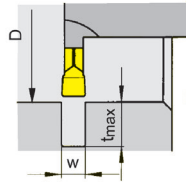

$w = .078 - .236"$
(2 - 6 mm)
 $t_{max} = .512"$ (13 mm)
 $D \geq 1.102"$ (28 mm)

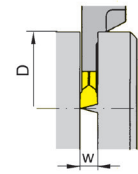

$w = .078 - .236"$
(2 - 6 mm)
 $D = 2.205"$ (56 mm)
 $t_{max} = .709"$ (18 mm)

Toolholder
HU224/H224BU224/
B224

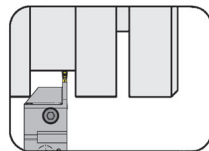

Page
G4

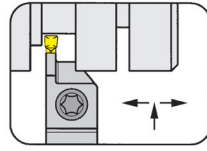

Page
G5-G24

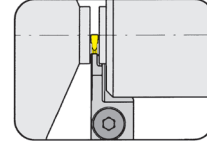

Page
G26

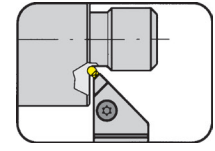

Page
G25

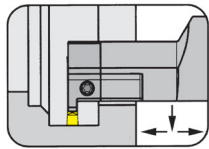

Page
G34-G36

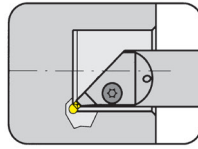

Page
G39-G41

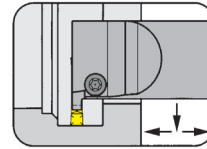

Page
G27-G33

Cassette
BK224/BK224...IK

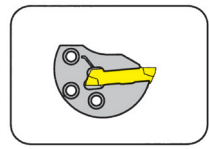

Page
G37-G38

Insert
S224/S124

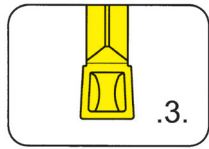

Page
G43

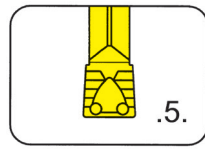

Page
G45

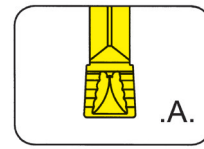

Page
G47

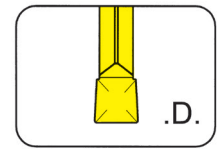

Page
G49

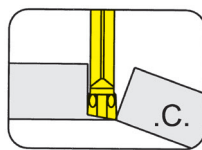

Page
G51

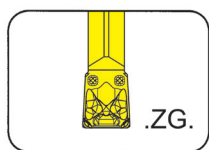

Page
G52

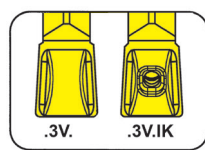

Page
G53, G67

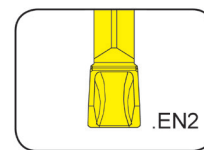

Page
G54

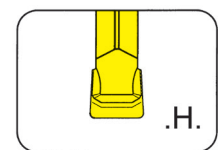

Page
G55

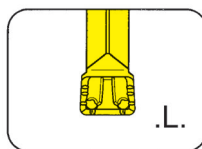

Page
G56-G57

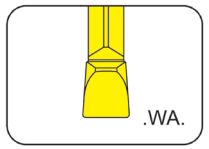

Page
G58

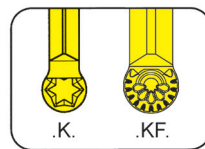

Page
G59-G60

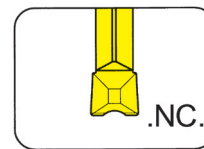

Page
G61

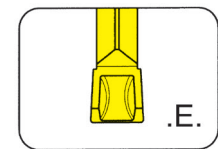

Page
G62

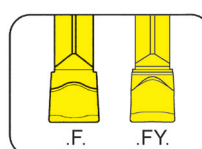

Page
G63-G64

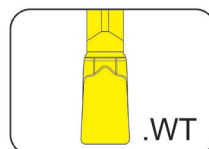

Page
G65

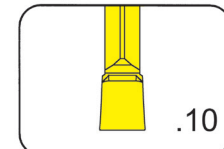

Page
G66

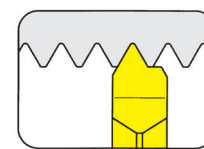

Page
G68-G69

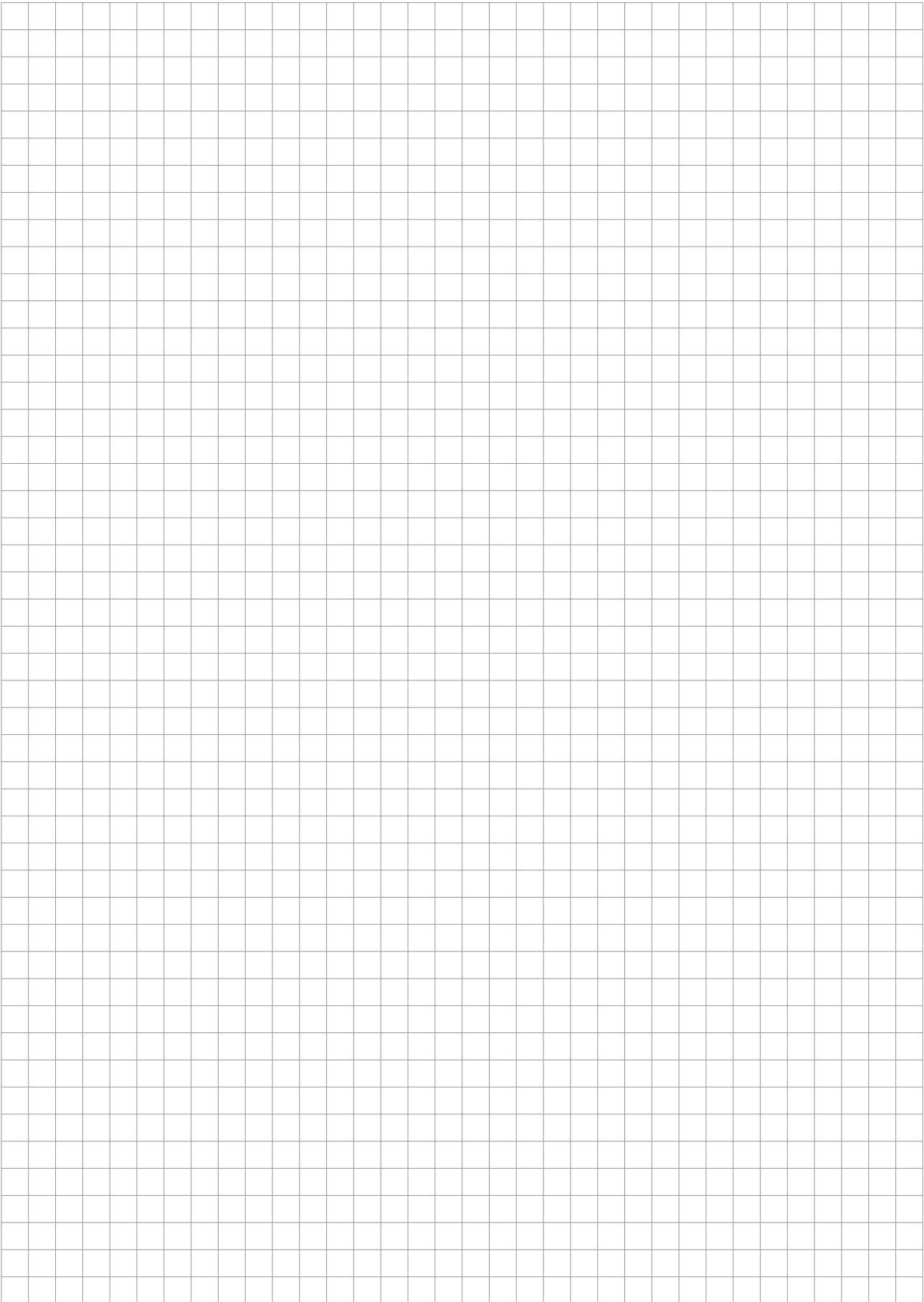

G

Toolholder

H224

with screwed clamping

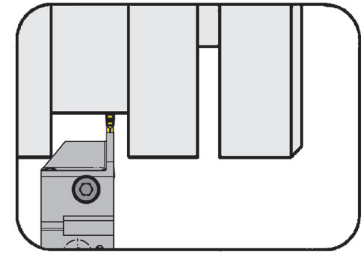

Depth of groove up to
Width of groove

18 mm
3 mm

for Indexable insert

Type S224...IK

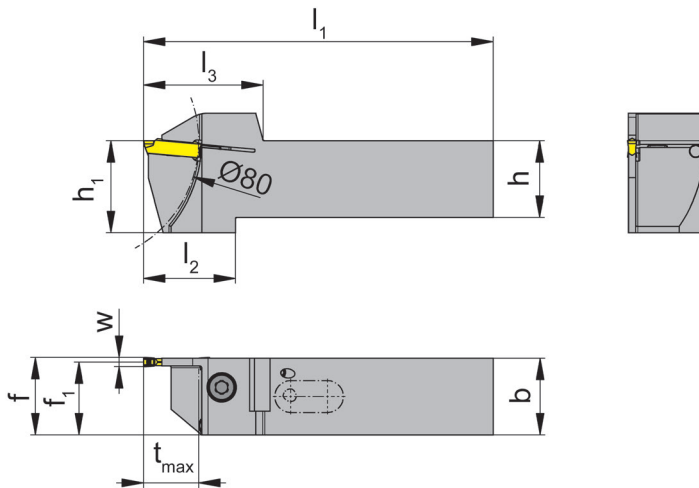

L = left hand version shown

R = right hand version

Coolant supply through
insert

Part number	h	b	l ₁	l ₂	l ₃	h ₁	f ₁	f	t _{max}	Size
R/LH224.1616.3.23.IK	16	16	87	33	39	25	14.75	f ₁ +w/2	18	03
R/LH224.2020.3.23.IK	20	20	99	30	39	25	18.75	f ₁ +w/2	18	03
R/LH224.2525.3.23.IK	25	25	114	30	39	30	23.75	f ₁ +w/2	18	03

State R or L version

w see indexable inserts

Dimensions in mm

Further sizes upon request

For torque specification of the screw, please see Technical Instructions.

Spare Parts

Toolholder	Clamping Screw	TORX PLUS® Wrench	O-ring	Threaded Pin
R/LH224...3.23.IK	6.23T25P	T25PQ	12.37.2.62.3601	4.06.913

Toolholder

HU224

with screwed clamping

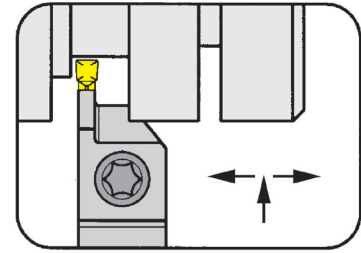

Depth of groove up to .551"
Clamping range .146"

for Indexable insert

Type S124
S224
NS224

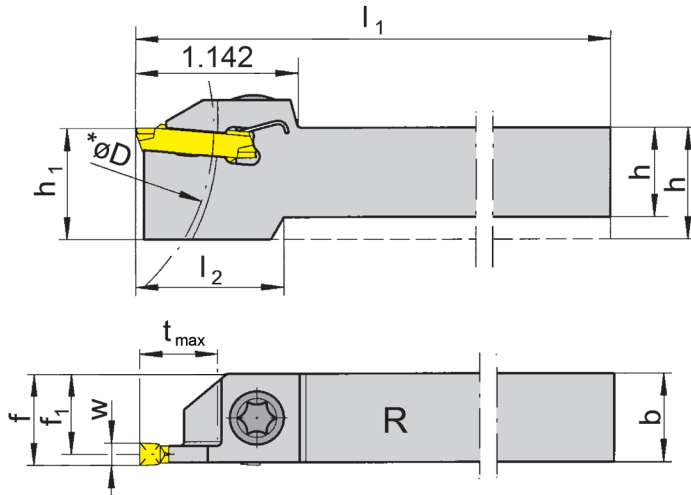

R = right hand version shown

L = left hand version

Part number	h	b	l ₁	l ₂	h ₁	f ₁	f	t _{max}	D _{max}	Size	Clamping range
R/LHU224.0625.01	.625	.625	5.118	.984	.787	.597	f ₁ +w/2	.551	3.15	01	.079 - .094
R/LHU224.0750.01	.750	.750	5.118	-	.750	.722	f ₁ +w/2	.551	3.15	01	.079 - .094
R/LHU224.1000.01	1.000	1.000	6.004	-	1.000	.972	f ₁ +w/2	.551	3.15	01	.079 - .094
R/LHU224.0625.02	.625	.625	5.118	.984	.787	.589	f ₁ +w/2	.551	3.15	02	.094 - .110
R/LHU224.0750.02	.750	.750	5.118	-	.750	.715	f ₁ +w/2	.551	3.15	02	.094 - .110
R/LHU224.1000.02	1.000	1.000	6.004	-	1.000	.965	f ₁ +w/2	.551	3.15	02	.094 - .110
R/LHU224.0625.03	.625	.625	4.921	.984	.787	.581	f ₁ +w/2	.551	3.15	03	.110 - .146
R/LHU224.0750.03	.750	.750	5.118	-	.750	.707	f ₁ +w/2	.551	3.15	03	.110 - .146
R/LHU224.1000.03	1.000	1.000	6.004	-	1.000	.957	f ₁ +w/2	.551	3.15	03	.110 - .146

State R or L version

w see indexable inserts

Dimensions in inch

Further sizes upon request

* t_{max} up to D = 3.150"

For torque specification of the screw, please see Technical Instructions.

Spare Parts

Toolholder	Clamping Screw	TORX PLUS® Wrench
R/LHU224...	6.23T25P	T25PQ



Grooving and Side Turning (external)



Toolholder

H224

with screwed clamping

Depth of groove up to
Clamping range

14 mm
2 - 3.7 mm

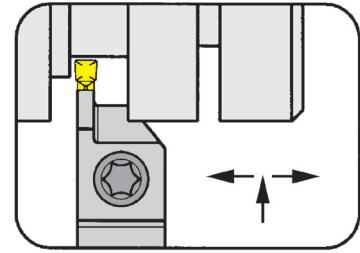

for Indexable insert

Type S124
S224
NS224

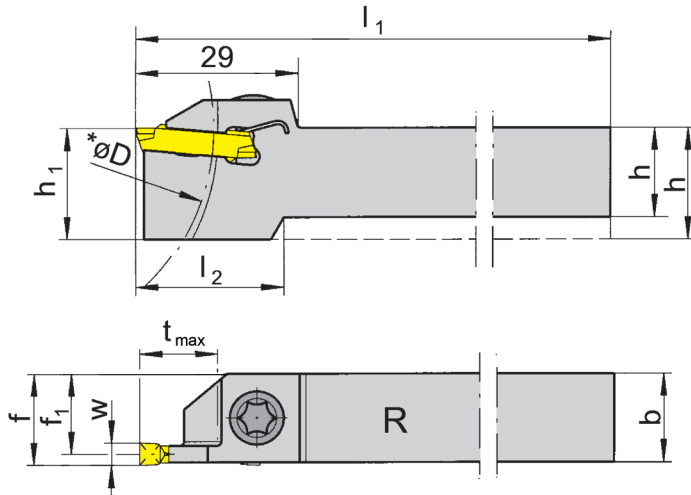

R = right hand version shown

L = left hand version

Part number	h	b	l ₁	l ₂	h ₁	f ₁	f	t _{max}	D _{max}	Size	Clamping range
R/LH224.1616.01	16	16	125	25	20	15.3	f ₁ +w/2	14	80	01	2.0 - 2.4
R/LH224.2020.01	20	20	125	-	20	19.3	f ₁ +w/2	14	80	01	2.0 - 2.4
R/LH224.2525.01	25	25	150	-	25	24.3	f ₁ +w/2	14	80	01	2.0 - 2.4
R/LH224.1616.02	16	16	125	25	20	15.1	f ₁ +w/2	14	80	02	2.4 - 2.8
R/LH224.2020.02	20	20	125	-	20	19.1	f ₁ +w/2	14	80	02	2.4 - 2.8
R/LH224.2525.02	25	25	150	-	25	24.1	f ₁ +w/2	14	80	02	2.4 - 2.8
R/LH224.1616.03	16	16	125	25	20	14.9	f ₁ +w/2	14	80	03	2.8 - 3.7
R/LH224.2020.03	20	20	125	-	20	18.9	f ₁ +w/2	14	80	03	2.8 - 3.7
R/LH224.2525.03	25	25	150	-	25	23.9	f ₁ +w/2	14	80	03	2.8 - 3.7

State R or L version

w see indexable inserts

Dimensions in mm

Further sizes upon request

* t_{max} up to D = 80 mm

For torque specification of the screw, please see Technical Instructions.

Spare Parts

Toolholder	Clamping Screw	TORX PLUS® Wrench
R/LH224...	6.23T25P	T25PQ

Toolholder

HU224

with screwed clamping

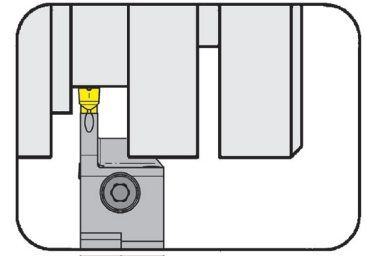

Depth of groove up to	.551"
Width of groove	.118"

for Indexable insert

Type S124
S224
NS224

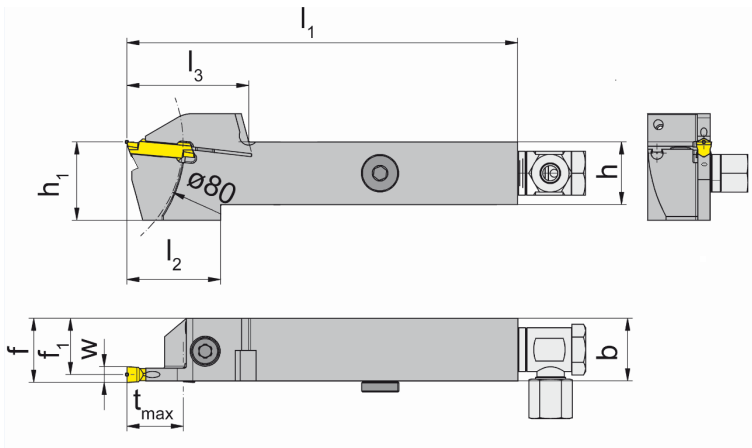

with through coolant supply

R = right hand version shown

L = left hand version

Part number	b	l ₁	l ₂	l ₃	h ₁	f ₁	t _{max}	Size
R/LHU224.1000.6.03.IK	1.000	6.004	1.024	1.378	1.197	.951	.551	03

State R or L version

w see indexable inserts

Dimensions in inch

Further sizes upon request

For torque specification of the screw, please see Technical Instructions.

Spare Parts

Toolholder	Coolant supply	Screw	Clamping Screw	TORX PLUS® Wrench
R/LHU224.1000.6.03.IK	004.00.61	004.00.21	6.23T25P	T25PQ



Grooving and Side Turning (external)



Toolholder

H224

with screwed clamping

Depth of groove up to
Clamping range

14 mm
2 - 3.7 mm

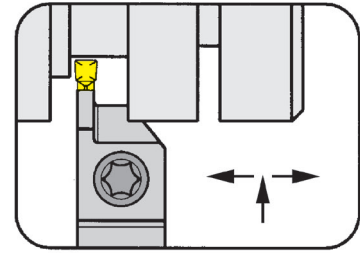

for Indexable insert

Type S124
S224
NS224

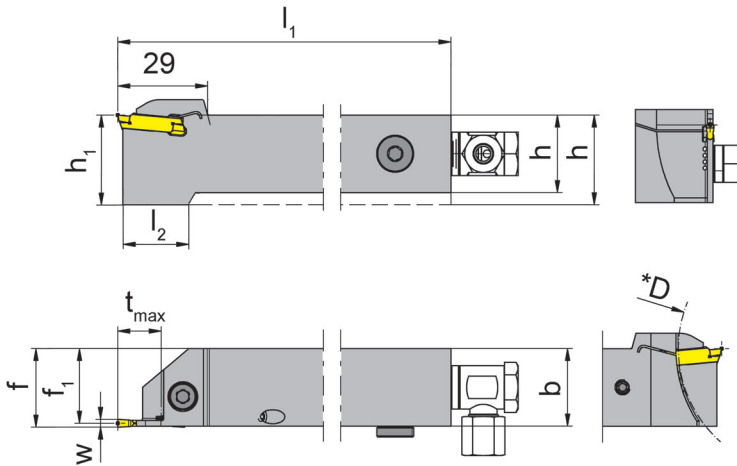

R = right hand version shown

L = left hand version

with through coolant supply

Part number	h	b	l ₁	l ₂	h ₁	f ₁	f	t _{max}	D _{max}	Size	Clamping range
R/LH224.1616.01.IK	16	16	125	25	20	15.3	f ₁ +w/2	14	80	01	2.0 - 2.4
R/LH224.2020.01.IK	20	20	125	-	20	19.3	f ₁ +w/2	14	80	01	2.0 - 2.4
R/LH224.2525.01.IK	25	25	150	-	25	24.3	f ₁ +w/2	14	80	01	2.0 - 2.4
R/LH224.1616.02.IK	16	16	125	25	20	15.1	f ₁ +w/2	14	80	02	2.4 - 2.8
R/LH224.2020.02.IK	20	20	125	-	20	19.1	f ₁ +w/2	14	80	02	2.4 - 2.8
R/LH224.2525.02.IK	25	25	150	-	25	24.1	f ₁ +w/2	14	80	02	2.4 - 2.8
R/LH224.1616.03.IK	16	16	125	25	20	14.9	f ₁ +w/2	14	80	03	2.8 - 3.7
R/LH224.2020.03.IK	20	20	125	-	20	18.9	f ₁ +w/2	14	80	03	2.8 - 3.7
R/LH224.2525.03.IK	25	25	150	-	25	23.9	f ₁ +w/2	14	80	03	2.8 - 3.7

State R or L version

w see indexable inserts

Dimensions in mm

Further sizes upon request

* t_{max} up to D = 80 mm

For torque specification of the screw, please see Technical Instructions.

Spare Parts

Toolholder	Sealing plug	Threaded Pin	Coolant supply	Clamping Screw	TORX PLUS® Wrench
R/LH224...	004.00.26	18.05.913	004.00.16	6.23T25P	T25PQ

Toolholder

H224

with screwed clamping

Depth of groove up to
Width of groove

14 mm
3 - 5 mm

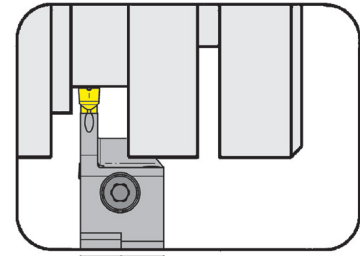

for Indexable insert

Type S124
S224
NS224

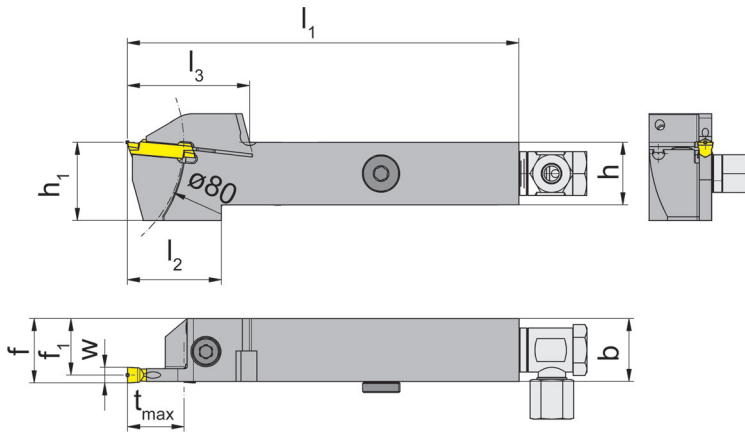

with through coolant supply

R = right hand version shown

L = left hand version

Part number	h	b	l_1	l_2	l_3	h_1	f_1	f	t_{max}	Size
R/LH224.1616.0.03.IK	16	16	125	29	35	25	14.75	$f_1+w/2$	14	03
R/LH224.2020.0.03.IK	20	20	125	26	35	25	18.75	$f_1+w/2$	14	03
R/LH224.2525.0.03.IK	25	25	150	26	35	30	23.75	$f_1+w/2$	14	03
R/LH224.1616.0.04.IK	16	16	125	29	35	25	14.30	$f_1+w/2$	14	04
R/LH224.2020.0.04.IK	20	20	125	26	35	25	18.30	$f_1+w/2$	14	04
R/LH224.2525.0.04.IK	25	25	150	26	35	30	23.30	$f_1+w/2$	14	04
R/LH224.1616.0.05.IK	16	16	125	29	35	25	13.95	$f_1+w/2$	14	05
R/LH224.2020.0.05.IK	20	20	125	26	35	25	17.95	$f_1+w/2$	14	05
R/LH224.2525.0.05.IK	25	25	150	26	35	30	22.95	$f_1+w/2$	14	05

State R or L version

w see indexable inserts

Dimensions in mm

Further sizes upon request

For torque specification of the screw, please see Technical Instructions.

Spare Parts

Toolholder	Sealing plug	Threaded Pin	Coolant supply	Clamping Screw	TORX PLUS® Wrench
RH224...0.03./04/05.IK	004.00.26	18.05.913	004.00.16	6.23T25P	T25PQ

Grooving and Side Turning (external)



Toolholder

HU224

with screwed clamping

Depth of groove up to
Clamping range

.551"
.146 - .240"

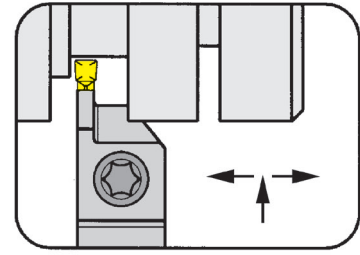

for Indexable insert

Type S124
S224
NS224

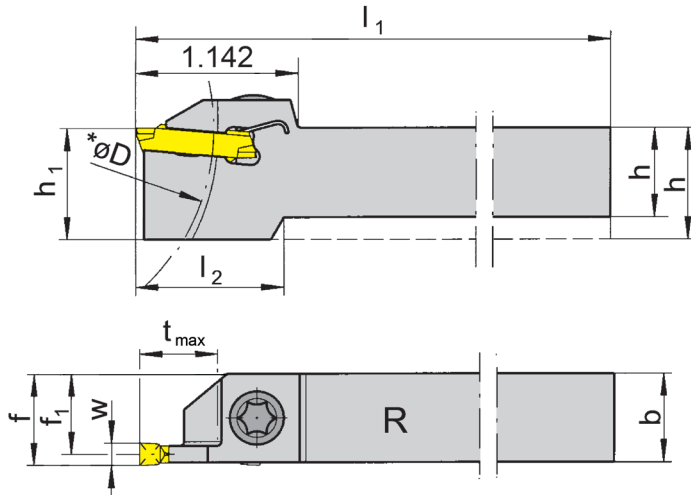

R = right hand version shown

L = left hand version

Part number	h	b	l ₁	l ₂	h ₁	f ₁	f	t _{max}	D _{max}	Size	Clamping range
R/LHU224.0625.04	.625	.625	5.118	.984	.787	.568	f ₁ +w/2	.551	3.15	04	.146 - .173
R/LHU224.0750.04	.750	.750	5.118	-	.750	.693	f ₁ +w/2	.551	3.15	04	.146 - .173
R/LHU224.1000.04	1.000	1.000	6.004	-	1.000	.943	f ₁ +w/2	.551	3.15	04	.146 - .173
R/LHU224.0750.05	.750	.750	5.118	-	.750	.677	f ₁ +w/2	.551	3.15	05	.173 - .201
R/LHU224.1000.05	1.000	1.000	6.004	-	1.000	.927	f ₁ +w/2	.551	3.15	05	.173 - .201
RHU224.0625.05	.625	.625	5.118	.984	.787	.552	f ₁ +w/2	.551	3.15	05	.173 - .201
R/LHU224.0750.06	.750	.750	5.118	-	.750	.661	f ₁ +w/2	.551	3.15	06	.201 - .240
R/LHU224.1000.06	1.000	1.000	6.004	-	1.000	.911	f ₁ +w/2	.551	3.15	06	.201 - .240

State R or L version

w see indexable inserts

Dimensions in inch

Further sizes upon request

* t_{max} up to D = 3.150"

For torque specification of the screw, please see Technical Instructions.

Spare Parts

Toolholder	Clamping Screw	TORX PLUS® Wrench
R/LHU224...	6.23T25P	T25PQ

Grooving and Side Turning (external)



Toolholder

H224

with screwed clamping

Depth of groove up to
Clamping range

14 mm
3.7 - 6.1 mm

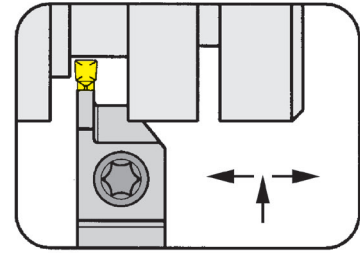

for Indexable insert

Type S124
S224
NS224

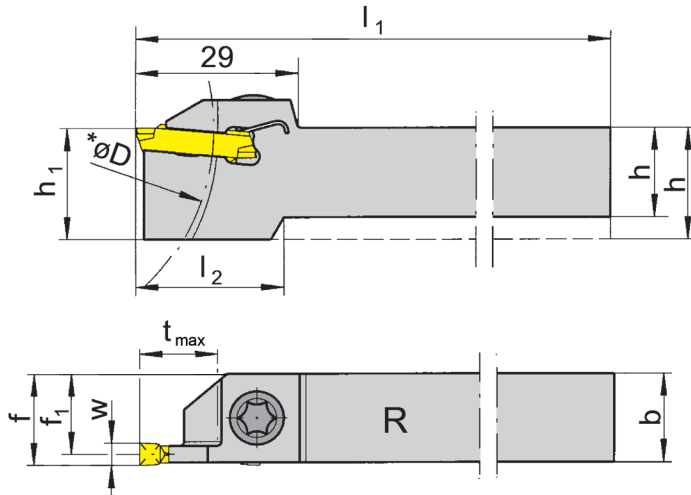

R = right hand version shown

L = left hand version

Part number	h	b	l ₁	l ₂	h ₁	f ₁	f	t _{max}	D _{max}	Size	Clamping range
R/LH224.1616.04	16	16	125	25	20	14.55	f ₁ +w/2	14	80	04	3.7 - 4.4
R/LH224.2020.04	20	20	125	-	20	18.55	f ₁ +w/2	14	80	04	3.7 - 4.4
R/LH224.2525.04	25	25	150	-	25	23.55	f ₁ +w/2	14	80	04	3.7 - 4.4
R/LH224.1616.05	16	16	125	-	20	18.15	f ₁ +w/2	14	80	05	4.4 - 5.1
R/LH224.2020.05	20	20	125	-	20	18.15	f ₁ +w/2	14	80	05	4.4 - 5.1
R/LH224.2525.05	25	25	150	-	25	23.15	f ₁ +w/2	14	80	05	4.4 - 5.1
R/LH224.2020.06	20	20	125	-	20	17.75	f ₁ +w/2	14	80	06	5.1 - 6.1
R/LH224.2525.06	25	25	150	-	25	22.75	f ₁ +w/2	14	80	06	5.1 - 6.1

State R or L version

w see indexable inserts

Dimensions in mm

Further sizes upon request

* t_{max} up to D = 80 mm

For torque specification of the screw, please see Technical Instructions.

Spare Parts

Toolholder	Clamping Screw	TORX PLUS® Wrench
R/LH224...	6.23T25P	T25PQ



Toolholder

HU224

with screwed clamping

Depth of groove up to
Clamping range

.709"
.079 - .146"

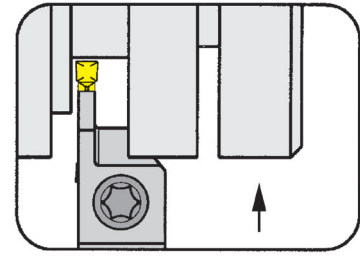

for Indexable insert

Type S124
S224
NS224

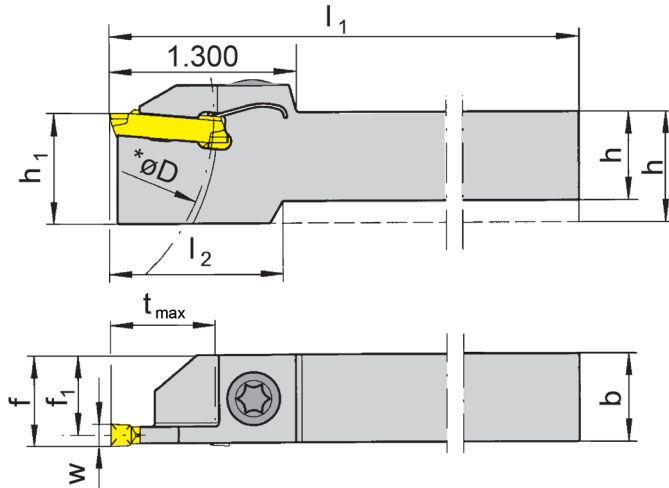

R = right hand version shown

L = left hand version

Part number	h	b	l ₁	l ₂	h ₁	f ₁	f	t _{max}	D _{max}	Size	Clamping range
R/LHU224.0625.21	.625	.625	5.118	1.299	.787	.597	f ₁ +w/2	.709	3.15	01	.079 - .094
R/LHU224.0750.21	.750	.750	4.921	1.299	.750	.722	f ₁ +w/2	.709	3.15	01	.079 - .094
R/LHU224.1000.21	1.000	1.000	6.004	1.299	1.000	.972	f ₁ +w/2	.709	3.15	01	.079 - .094
R/LHU224.0625.22	.625	.625	5.118	1.299	.787	.589	f ₁ +w/2	.709	3.15	02	.094 - .110
R/LHU224.0750.22	.750	.750	4.921	1.299	.750	.715	f ₁ +w/2	.709	3.15	02	.094 - .110
R/LHU224.1000.22	1.000	1.000	6.004	1.299	1.000	.965	f ₁ +w/2	.709	3.15	02	.094 - .110
R/LHU224.0625.23	.625	.625	4.921	1.299	.787	.581	f ₁ +w/2	.709	3.15	03	.110 - .146
R/LHU224.0750.23	.750	.750	4.921	1.299	.750	.707	f ₁ +w/2	.709	3.15	03	.110 - .146
R/LHU224.1000.23	1.000	1.000	6.004	1.299	1.000	.957	f ₁ +w/2	.709	3.15	03	.110 - .146

State R or L version

w see indexable inserts

Dimensions in inch

Further sizes upon request

* t_{max} up to D = 3.150"

For torque specification of the screw, please see Technical Instructions.

Spare Parts

Toolholder	Clamping Screw	TORX PLUS® Wrench
R/LHU224...	6.23T25P	T25PQ

Toolholder

H224

with screwed clamping

Depth of groove up to
Clamping range

18 mm
2 - 3.7 mm

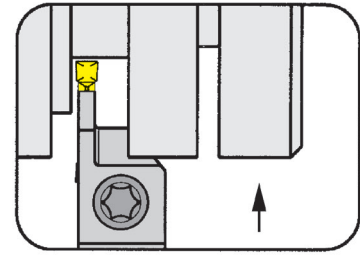

for Indexable insert

Type S124
S224
NS224

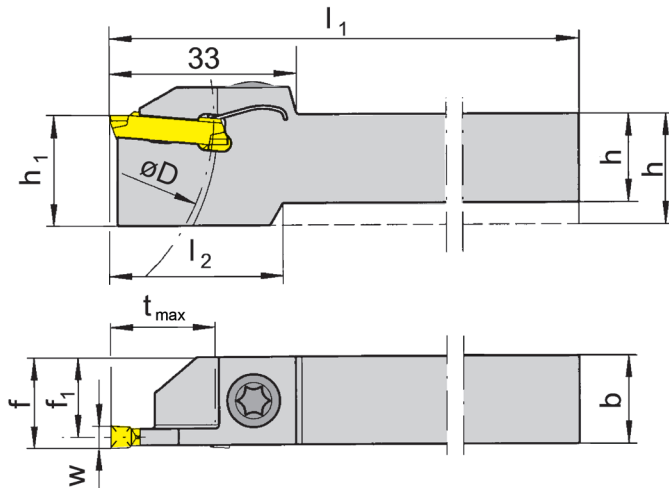

R = right hand version shown

L = left hand version

Part number	h	b	l ₁	l ₂	h ₁	f ₁	f	t _{max}	D _{max}	Size	Clamping range
R/LH224.1212.21	12	12	125	33	20	11.3	f ₁ +w/2	18	80	01	2.0 - 2.4
R/LH224.1616.21	16	16	125	30	20	15.3	f ₁ +w/2	18	80	01	2.0 - 2.4
R/LH224.2020.21	20	20	125	-	20	19.3	f ₁ +w/2	18	80	01	2.0 - 2.4
R/LH224.2525.21	25	25	150	-	25	24.3	f ₁ +w/2	18	80	01	2.0 - 2.4
R/LH224.1616.22	16	16	125	30	20	15.1	f ₁ +w/2	18	80	02	2.4 - 2.8
RH224.1608.02	16	8	100	30	20	7.1	f ₁ +w/2	14	80	02	2.4 - 2.8
R/LH224.2020.22	20	20	125	-	20	19.1	f ₁ +w/2	18	80	02	2.4 - 2.8
R/LH224.1212.22	12	12	125	33	20	11.1	f ₁ +w/2	18	80	02	2.4 - 2.8
R/LH224.2525.22	25	25	150	-	25	24.1	f ₁ +w/2	18	80	02	2.4 - 2.8
R/LH224.1608.23	16	8	100	-	20	6.9	f ₁ +w/2	18	80	03	2.8 - 3.7
R/LH224.1616.23	16	16	125	30	20	14.9	f ₁ +w/2	18	80	03	2.8 - 3.7
R/LH224.2020.23	20	20	125	-	20	18.9	f ₁ +w/2	18	80	03	2.8 - 3.7
R/LH224.2525.23	25	25	150	-	25	23.9	f ₁ +w/2	18	80	03	2.8 - 3.7
R/LH224.1212.23	12	12	125	33	20	10.9	f ₁ +w/2	18	80	03	2.8 - 3.7

State R or L version

w see indexable inserts

Dimensions in mm

Further sizes upon request

* t_{max} up to D = 80 mm

Spare Parts

Toolholder	Clamping Screw	TORX PLUS® Wrench
R/LH224...	6.23T25P	T25PQ
RH224.1608.02	4.15T15P	T15PL
R/LH224.1608.23	4.15T15P	T15PQ



Toolholder

H224

with screwed clamping

Depth of groove up to
Clamping range

18 mm
2 - 3.7 mm

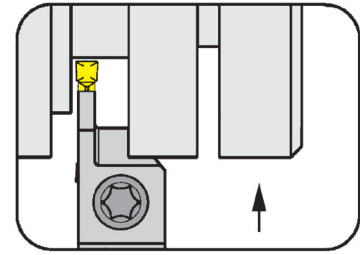

for Indexable insert

Type S124
S224
NS224

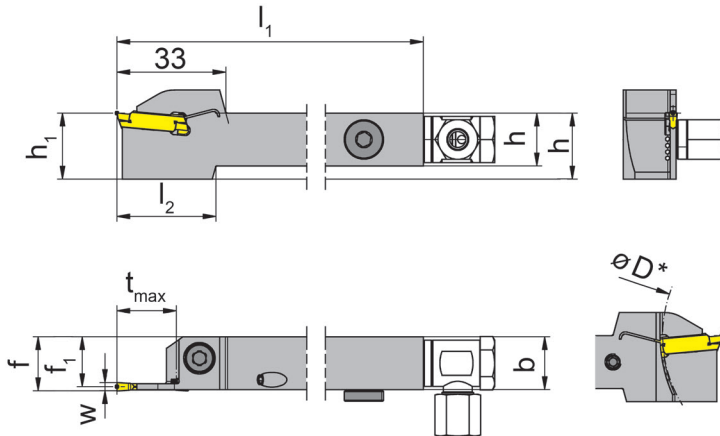

with through coolant supply

R = right hand version shown

L = left hand version

Part number	h	b	l ₁	l ₂	h ₁	f ₁	f	t _{max}	D _{max}	Size	Clamping range
R/LH224.1212.21.IK	12	12	125	33	20	11.3	f ₁ +w/2	18	80	01	2.0 - 2.4
R/LH224.1616.21.IK	16	16	125	30	20	15.3	f ₁ +w/2	18	80	01	2.0 - 2.4
R/LH224.2020.21.IK	20	20	125	-	20	19.3	f ₁ +w/2	18	80	01	2.0 - 2.4
R/LH224.2525.21.IK	25	25	150	-	25	24.3	f ₁ +w/2	18	80	01	2.0 - 2.4
R/LH224.1212.22.IK	12	12	125	33	20	11.1	f ₁ +w/2	18	80	02	2.4 - 2.8
R/LH224.1616.22.IK	16	16	125	30	20	15.1	f ₁ +w/2	18	80	02	2.4 - 2.8
R/LH224.2020.22.IK	20	20	125	-	20	19.1	f ₁ +w/2	18	80	02	2.4 - 2.8
R/LH224.2525.22.IK	25	25	150	-	25	24.1	f ₁ +w/2	18	80	02	2.4 - 2.8
R/LH224.1212.23.IK	12	12	125	33	20	10.9	f ₁ +w/2	18	80	03	2.8 - 3.7
R/LH224.1616.23.IK	16	16	125	30	20	14.9	f ₁ +w/2	18	80	03	2.8 - 3.7
R/LH224.2020.23.IK	20	20	125	-	20	18.9	f ₁ +w/2	18	80	03	2.8 - 3.7
R/LH224.2525.23.IK	25	25	150	-	25	23.9	f ₁ +w/2	18	80	03	2.8 - 3.7

State R or L version

w see indexable inserts

Dimensions in mm

Further sizes upon request

* t_{max} up to D = 80 mm

For torque specification of the screw, please see Technical Instructions.

Spare Parts

Toolholder	Threaded Pin	Coolant supply	Clamping Screw	TORX PLUS® Wrench	Sealing plug	Screw
R/LH224.1212...IK		004.00.61	6.23T25P	T25PQ		
R/LH224...21/.22/.23.IK	18.05.913	004.00.16	6.23T25P	T25PQ	004.00.26	

Toolholder

H224

with screwed clamping

Depth of groove up to
Width of groove

18 mm
3 - 5 mm

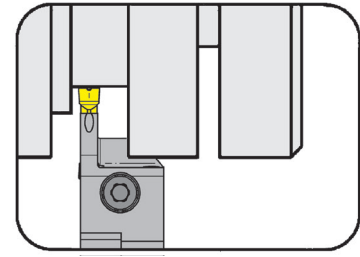

for Indexable insert

Type S124
S224
NS224

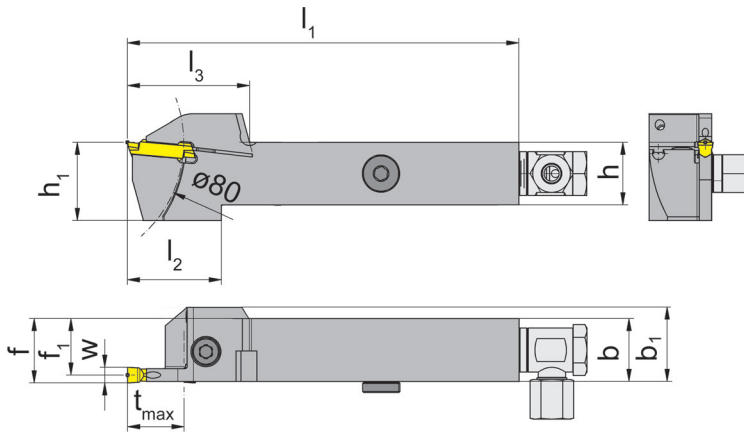

with through coolant supply

R = right hand version shown

L = left hand version

Part number	h	b	l ₁	l ₂	l ₃	h ₁	b ₁	f ₁	f	t _{max}	Size
R/LH224.1616.0.23.IK	16	16	125	33	39	25	20	14.75	f ₁ +w/2	18	03
R/LH224.2020.0.23.IK	20	20	125	30	39	25	-	18.75	f ₁ +w/2	18	03
R/LH224.2525.0.23.IK	25	25	150	30	39	30	-	23.75	f ₁ +w/2	18	03
R/LH224.1616.0.24.IK	16	16	125	33	39	25	20	14.30	f ₁ +w/2	18	04
R/LH224.2020.0.24.IK	20	20	125	30	39	25	-	18.30	f ₁ +w/2	18	04
R/LH224.2525.0.24.IK	25	25	150	30	39	30	-	23.30	f ₁ +w/2	18	04
R/LH224.1616.0.25.IK	16	16	125	33	39	25	20	13.95	f ₁ +w/2	18	05
R/LH224.2020.0.25.IK	20	20	125	30	39	25	-	17.95	f ₁ +w/2	18	05
R/LH224.2525.0.25.IK	25	25	150	30	39	30	-	23.95	f ₁ +w/2	18	05

State R or L version

w see indexable inserts

Dimensions in mm

Further sizes upon request

For torque specification of the screw, please see Technical Instructions.

Spare Parts

Toolholder	Sealing plug	Threaded Pin	Coolant supply	Clamping Screw	TORX PLUS® Wrench
R/L224...0.23/.24/.25.IK	004.00.26	18.05.913	004.00.16	6.23T25P	T25PQ

Grooving (external)



Toolholder

HU224

with screwed clamping

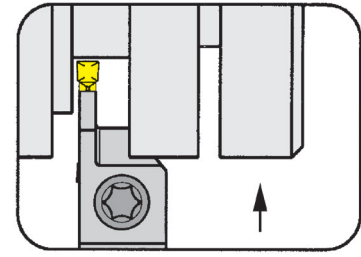

Depth of groove up to .709"
Clamping range .146 - .240"

for Indexable insert

Type S124
S224
NS224

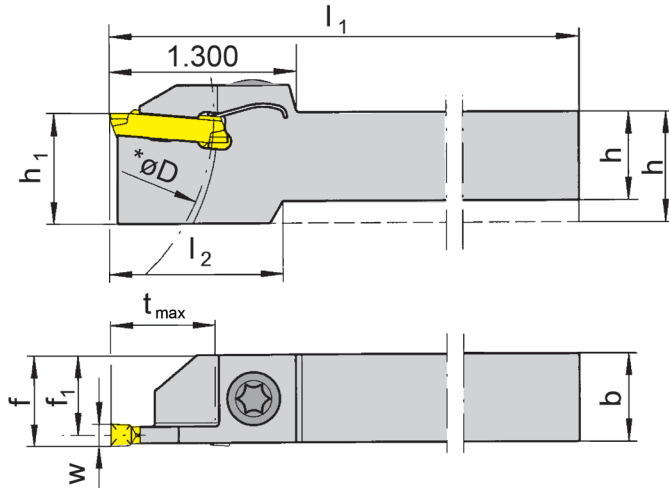

R = right hand version shown

L = left hand version

Part number	h	b	l ₁	l ₂	h ₁	f ₁	f	t _{max}	D _{max}	Size	Clamping range
R/LHU224.0625.24	.625	.625	5.118	1.299	.787	.568	f ₁ +w/2	.709	3.15	04	.146 - .173
R/LHU224.0750.24	.750	.750	4.921	1.299	.750	.693	f ₁ +w/2	.709	3.15	04	.146 - .173
R/LHU224.1000.24	1.000	1.000	6.004	1.299	1.000	.943	f ₁ +w/2	.709	3.15	04	.146 - .173
R/LHU224.0625.25	.625	.625	5.000	1.299	.787	.552	f ₁ +w/2	.709	3.15	05	.173 - .201
R/LHU224.0750.25	.750	.750	4.921	1.299	.750	.677	f ₁ +w/2	.709	3.15	05	.173 - .201
R/LHU224.1000.25	1.000	1.000	6.004	1.299	1.000	.927	f ₁ +w/2	.709	3.15	05	.173 - .201
R/LHU224.0625.26	.625	.625	5.118	1.299	.787	.536	f ₁ +w/2	.709	3.15	06	.201 - .240
R/LHU224.0750.26	.750	.750	4.921	1.299	.750	.661	f ₁ +w/2	.709	3.15	06	.201 - .240
R/LHU224.1000.26	1.000	1.000	6.004	1.299	1.000	.911	f ₁ +w/2	.709	3.15	06	.201 - .240

State R or L version

w see indexable inserts

Dimensions in inch

Further sizes upon request

* t_{max} up to D = 3.150"

For torque specification of the screw, please see Technical Instructions.

Spare Parts

Toolholder	Clamping Screw	TORX PLUS® Wrench
R/LHU224...	6.23T25P	T25PQ

Toolholder

H224

with screwed clamping

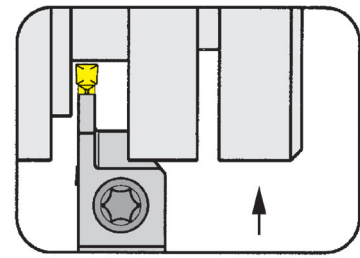

Depth of groove up to
Clamping range

18 mm
3.7 - 6.1 mm

for Indexable insert

Type S124
S224
NS224

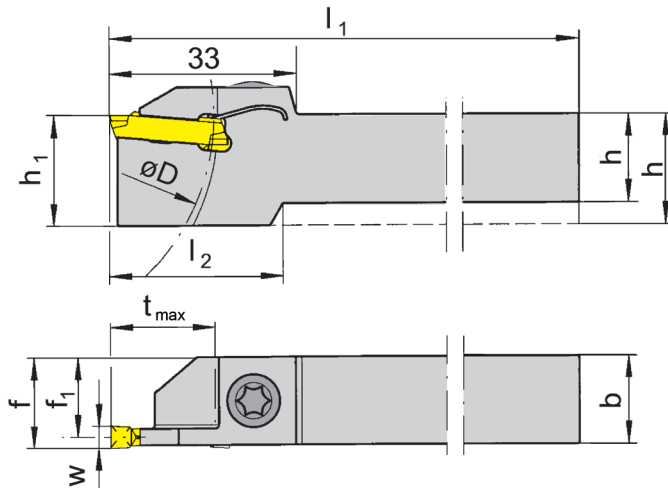

R = right hand version shown

L = left hand version

Part number	h	b	l ₁	l ₂	h ₁	f ₁	f	t _{max}	D _{max}	Size	Clamping range
LH224.1608.24	16	8	100	-	16	6.55	f ₁ +w/2	18	80	04	3.7 - 4.4
R/LH224.1616.24	16	16	125	30	20	14.55	f ₁ +w/2	18	80	04	3.7 - 4.4
R/LH224.2020.24	20	20	125	-	20	18.55	f ₁ +w/2	18	80	04	3.7 - 4.4
R/LH224.2525.24	25	25	150	-	25	23.55	f ₁ +w/2	18	80	04	3.7 - 4.4
R/LH224.1616.25	16	16	125	30	20	14.15	f ₁ +w/2	18	80	05	4.4 - 5.1
R/LH224.2020.25	20	20	125	-	20	18.15	f ₁ +w/2	18	80	05	4.4 - 5.1
R/LH224.2525.25	25	25	150	-	25	23.15	f ₁ +w/2	18	80	05	4.4 - 5.1
R/LH224.1616.26	16	16	125	30	20	13.75	f ₁ +w/2	18	80	06	5.1 - 6.1
R/LH224.2020.26	20	20	125	-	20	17.75	f ₁ +w/2	18	80	06	5.1 - 6.1
R/LH224.2525.26	25	25	150	-	25	22.75	f ₁ +w/2	18	80	06	5.1 - 6.1

State R or L version

w see indexable inserts

Dimensions in mm

Further sizes upon request

* t_{max} up to D = 80 mm

Spare Parts

Toolholder	Clamping Screw	TORX PLUS® Wrench
LH224.1608.24	4.15T15P	T15PQ
R/LH224...	6.23T25P	T25PQ



Grooving and Side Turning (external)



Toolholder

HU224

with screwed clamping

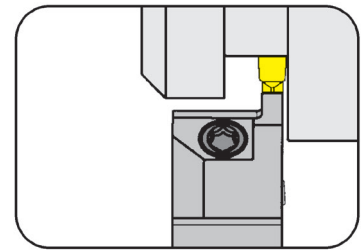

Depth of groove up to
Clamping range

.276"
.079 - .146"

for Indexable insert

Type S124
S224
NS224

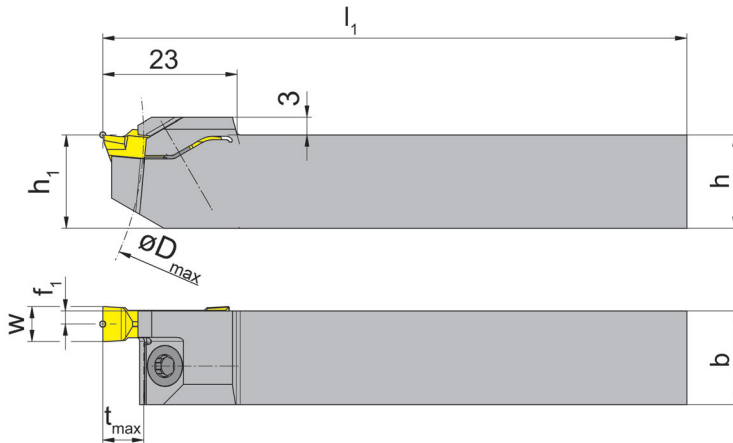

L = left hand version shown

R = right hand version

Part number	h	b	l ₁	h ₁	f ₁	t _{max}	D _{max}	Size	Clamping range
RHU224.0500.61	.500	.500	4.000	.500	.028	.276	3.937	01	.079 - .094
RHU224.0500.63	.500	.500	4.000	.500	.043	.276	3.937	03	.110 - .146

State R or L version

w see indexable inserts

Dimensions in inch

Further sizes upon request

For torque specification of the screw, please see Technical Instructions.

Spare Parts

Toolholder	Clamping Screw	TORX PLUS® Wrench
RHU224...	4.12T15EP	T15PQ

Grooving and Side Turning (external)



Toolholder

H224

with screwed clamping

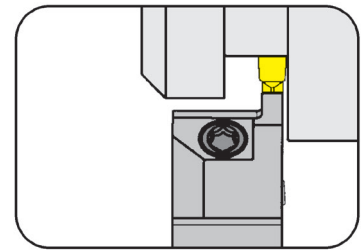

Depth of groove up to
Clamping range

7 mm
2 - 4.4 mm

for Indexable insert

Type S124
S224
NS224

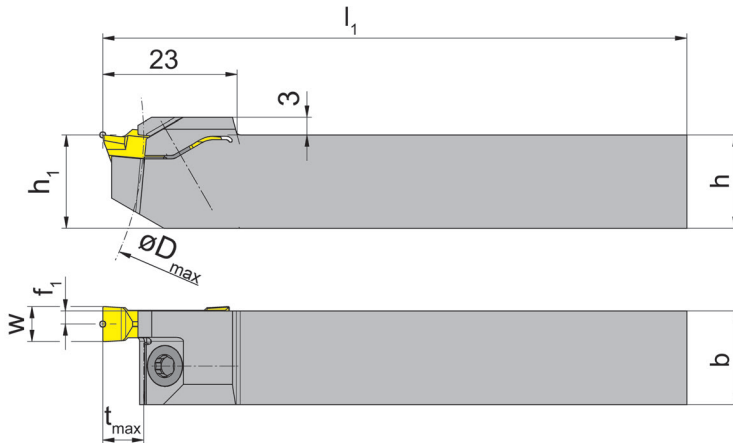

L = left hand version shown

R = right hand version

Part number	h	b	l ₁	h ₁	f ₁	t _{max}	D _{max}	Size	Clamping range
R/LH224.1212.61	12	12	100	12	.70	7	100	01	2.0 - 2.4
R/LH224.1616.61	16	16	100	16	.70	7	100	01	2.0 - 2.4
R/LH224.2020.61	20	20	100	20	.70	7	100	01	2.0 - 2.4
R/LH224.1212.62	12	12	100	12	.90	7	100	02	2.4 - 2.8
R/LH224.1616.62	16	16	100	16	.90	7	100	02	2.4 - 2.8
R/LH224.2020.62	20	20	100	20	.90	7	100	02	2.4 - 2.8
R/LH224.1212.63	12	12	100	12	1.10	7	100	03	2.8 - 3.7
R/LH224.1616.63	16	16	100	16	1.10	7	100	03	2.8 - 3.7
R/LH224.2020.63	20	20	100	20	1.10	7	100	03	2.8 - 3.7
R/LH224.1212.64	12	12	100	12	1.45	7	100	04	3.7 - 4.4
R/LH224.1616.64	16	16	100	16	1.45	7	100	04	3.7 - 4.4
R/LH224.2020.64	20	20	100	20	1.45	7	100	04	3.7 - 4.4

State R or L version

w see indexable inserts

Dimensions in mm

Further sizes upon request

For torque specification of the screw, please see Technical Instructions.

Spare Parts

Toolholder	Clamping Screw	TORX PLUS® Wrench
R/LH224...	4.12T15EP	T15PL

Grooving and Side Turning (external)



Toolholder

H224

with screwed clamping

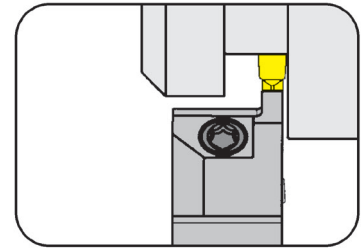

Depth of groove up to
Clamping range

7 mm
2 - 3.7 mm

for Indexable insert

Type S124
S224
NS224

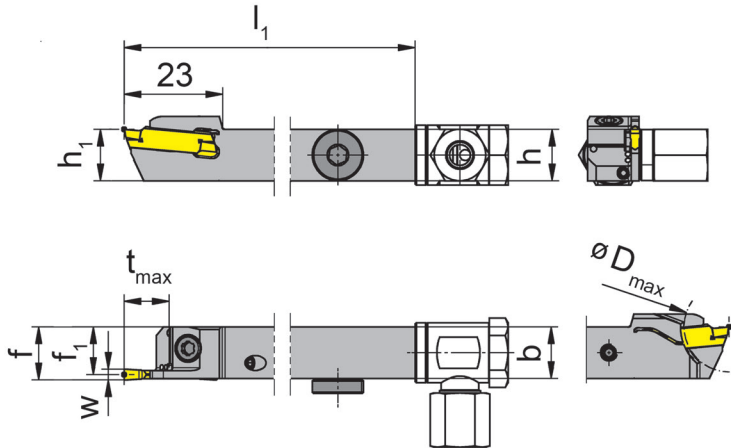

with through coolant supply

R = right hand version shown

L = left hand version

Part number	h	b	l_1	h_1	f_1	f	t_{max}	D_{max}	Size	Clamping range
R/LH224.1212.61.IK	12	12	100	12	.7	$f_1+w/2$	7	100	01	2.0 - 2.4
R/LH224.1616.61.IK	16	16	100	16	.7	$f_1+w/2$	7	100	01	2.0 - 2.4
R/LH224.2020.61.IK	20	20	100	20	.7	$f_1+w/2$	7	100	01	2.0 - 2.4
R/LH224.1212.62.IK	12	12	100	12	.9	$f_1+w/2$	7	100	02	2.4 - 2.8
R/LH224.1616.62.IK	16	16	100	16	.9	$f_1+w/2$	7	100	02	2.4 - 2.8
R/LH224.2020.62.IK	20	20	100	20	.9	$f_1+w/2$	7	100	02	2.4 - 2.8
R/LH224.1212.63.IK	12	12	100	12	1.1	$f_1+w/2$	7	100	03	2.8 - 3.7
R/LH224.1616.63.IK	16	16	100	16	1.1	$f_1+w/2$	7	100	03	2.8 - 3.7
R/LH224.2020.63.IK	20	20	100	20	1.1	$f_1+w/2$	7	100	03	2.8 - 3.7

State R or L version

w see indexable inserts

Dimensions in mm

Further sizes upon request

For torque specification of the screw, please see Technical Instructions.

Spare Parts

Toolholder	Clamping Screw	Coolant supply	TORX PLUS® Wrench	Sealing plug	Threaded Pin
R/LH224.1212...IK	4.12T15EP	004.00.61	T15PL		
R/LH224...61/.62/.63.IK	4.12T15EP	004.00.16	T15PL	004.00.26	18.05.913

Grooving and Side Turning (external)



Toolholder

HU224

with screwed clamping

Depth of groove up to
Clamping range

.413"
.079 - .146"

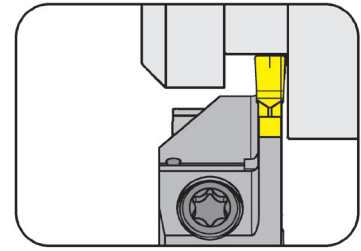

for Indexable insert

Type S124
S224
NS224

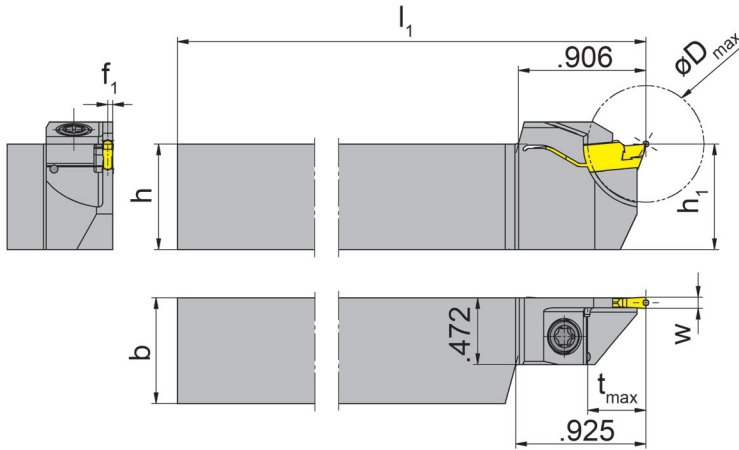

L = left hand version shown

R = right hand version

Part number	h	b	l ₁	l ₂	h ₁	f ₁	f	t _{max}	D _{max}	Size	Clamping range
R/LHU224.0500.20.61	.500	.500	4.000	.906	.500	.028	f ₁ +w/2	.413	.827	01	.079 - .094
R/LHU224.0625.20.61	.625	.625	3.937	.906	.625	.028	f ₁ +w/2	.413	.827	01	.079 - .094
R/LHU224.0750.20.61	.750	.750	5.118	.906	.750	.028	f ₁ +w/2	.413	.827	01	.079 - .094
R/LHU224.0500.20.62	.500	.500	4.000	.906	.500	.035	f ₁ +w/2	.413	.827	02	.094 - .110
R/LHU224.0625.20.62	.625	.625	3.937	.906	.625	.035	f ₁ +w/2	.413	.827	02	.094 - .110
R/LHU224.0750.20.62	.750	.750	5.118	.906	.750	.035	f ₁ +w/2	.413	.827	02	.094 - .110
R/LHU224.0500.20.63	.500	.500	4.000	.906	.500	.043	f ₁ +w/2	.413	.827	03	.110 - .146
R/LHU224.0625.20.63	.625	.625	3.937	.906	.625	.043	f ₁ +w/2	.413	.827	03	.110 - .146
R/LHU224.0750.20.63	.750	.750	5.118	.906	.750	.043	f ₁ +w/2	.413	.827	03	.110 - .146

State R or L version

w see indexable inserts

Dimensions in inch

Further sizes upon request

For torque specification of the screw, please see Technical Instructions.

Spare Parts

Toolholder	Clamping Screw	TORX PLUS® Wrench
R/LHU224...	4.12T15EP	T15PQ



Grooving and Side Turning (external)



Toolholder

H224

with screwed clamping

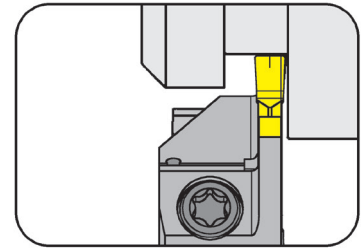

Depth of groove up to
Clamping range

10.5 mm
2 - 3.7 mm

for Indexable insert

Type S124
S224
NS224

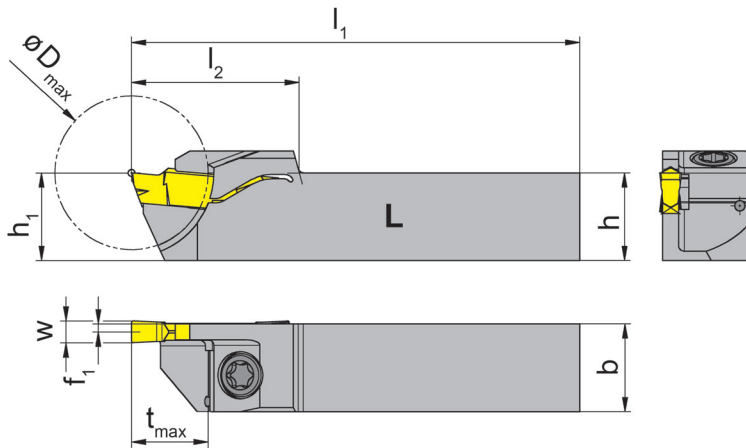

L = left hand version shown

R = right hand version

Part number	h	b	l ₁	l ₃	h ₁	f ₁	t _{max}	D _{max}	Size	Clamping range
R/LH224.1212.20.61	12	12	100	23	12	.7	10.5	21	01	2.0 - 2.4
R/LH224.1212.20.62	12	12	100	23	12	.9	10.5	21	02	2.4 - 2.8
R/LH224.1212.20.63	12	12	100	23	12	1.1	10.5	21	03	2.8 - 3.7

State R or L version

w see indexable inserts

Dimensions in mm

Further sizes upon request

For torque specification of the screw, please see Technical Instructions.

Spare Parts

Toolholder	Clamping Screw	TORX PLUS® Wrench
R/LH224...	4.12T15EP	T15PQ

G22

Call Us Toll Free (888) 818-4676

Grooving and Side Turning (external)



Toolholder

H224

with screwed clamping

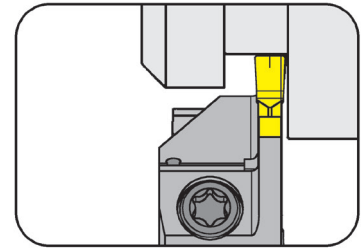

Depth of groove up to
Clamping range

10.5 mm
2 - 3.7 mm

for Indexable insert

Type S124
S224
NS224

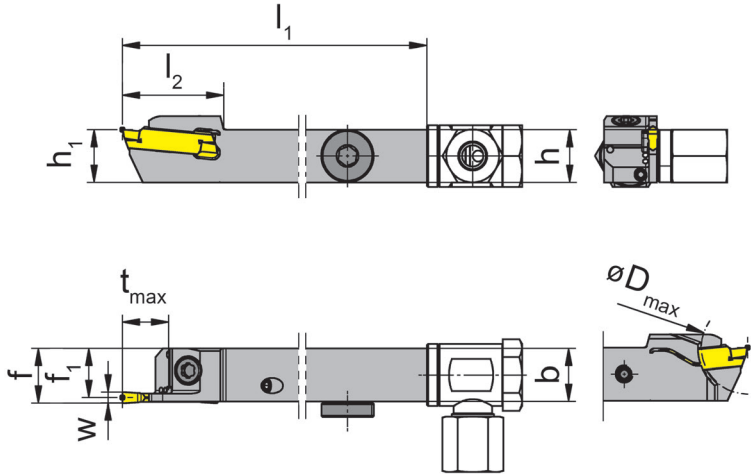

R = right hand version shown

L = left hand version

with through coolant supply

Part number	h	b	l ₁	l ₃	h ₁	f ₁	f	t _{max}	D _{max}	Size	Clamping range
R/LH224.1212.20.61.IK	12	12	100	23	12	.7	f ₁ +w/2	10.5	21	01	2.0 - 2.4
R/LH224.1212.20.62.IK	12	12	100	23	12	.9	f ₁ +w/2	10.5	21	02	2.4 - 2.8
R/LH224.1212.20.63.IK	12	12	100	23	12	1.1	f ₁ +w/2	10.5	21	03	2.8 - 3.7

State R or L version

w see indexable inserts

Dimensions in mm

Further sizes upon request

For torque specification of the screw, please see Technical Instructions.

Spare Parts

Toolholder	Clamping Screw	Coolant supply	TORX PLUS® Wrench
R/LH224.1212.20...IK	4.12T15EP	004.00.61	T15PL

Grooving and Side Turning (external)



Toolholder

H224

with screwed clamping

Depth of groove up to
Clamping range

7 mm
4.4 - 6.1 mm

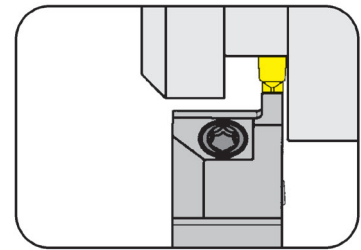

for Indexable insert

Type S124
S224
NS224

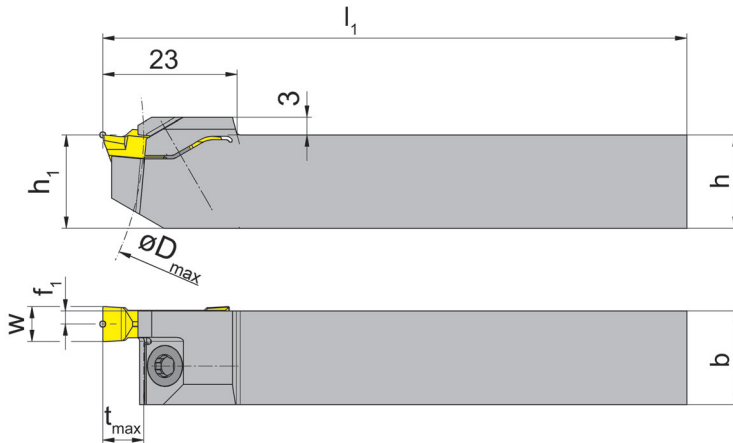

L = left hand version shown

R = right hand version

Part number	h	b	l ₁	h ₁	f ₁	t _{max}	D _{max}	Size	Clamping range
R/LH224.2020.65	20	20	100	20	1.85	7	100	05	4.4 - 5.1
R/LH224.1616.65	16	16	100	16	1.85	7	100	05	4.4 - 5.1
R/LH224.2020.66	20	20	100	20	2.25	7	100	06	5.1 - 6.1
R/LH224.1616.66	16	16	100	16	2.25	7	100	06	5.1 - 6.1

State R or L version

w see indexable inserts

Dimensions in mm

Further sizes upon request

For torque specification of the screw, please see Technical Instructions.

Spare Parts

Toolholder	Clamping Screw	TORX PLUS® Wrench
R/LH224...	5.13T20EP	T20PQ

G24

Call Us Toll Free (888) 818-4676

Grooving Corner Reliefs (external)



Toolholder

H224

with screwed clamping

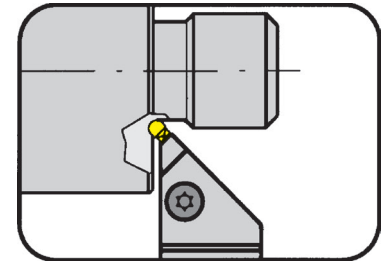

Width of groove

2 - 6.1 mm

for Indexable insert

Type S224

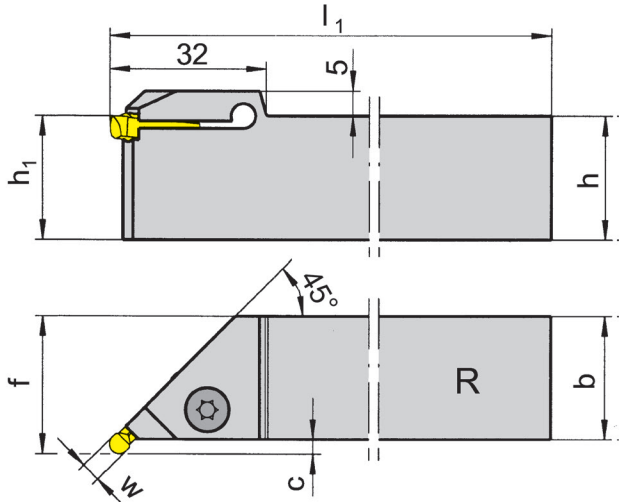

R = right hand version shown

L = left hand version

only for full radius inserts
S224...K

Part number	h	b	l_1	h_1	f	C	Size	Width of groove
R/LH224.4520.02	20	20	125	20	23.0	2.5	02	2.0 - 2.8
R/LH224.4525.02	25	25	150	25	28.0	2.5	02	2.0 - 2.8
R/LH224.4520.04	20	20	125	20	23.0	2.5	04	2.8 - 4.4
R/LH224.4525.04	25	25	150	25	28.0	2.5	04	2.8 - 4.4
R/LH224.4520.06	20	20	125	20	23.5	3.0	06	4.4 - 6.1
R/LH224.4525.06	25	25	150	25	28.5	3.0	06	4.4 - 6.1

State R or L version

w and Dmin see indexable inserts

Dimensions in mm

Further sizes upon request

For torque specification of the screw, please see Technical Instructions.

Revision factor Δl_1 , Δc and Δf in relation to radius r

r	Δl_1	Δc	Δf
3,0	0	0	0
2,5	-0,146	-0,146	-0,146
2,0	0	0	0
1,5	-0,146	-0,146	-0,146
1,0	0	0	0

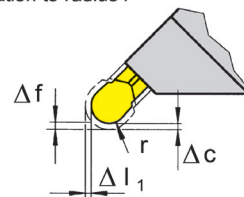

Spare Parts

Toolholder	Clamping Screw	TORX PLUS® Wrench
R/LH224...	6.23T25P	T25PQ

Call Us Toll Free (888) 818-4676

G25

Toolholder

H224

with screwed clamping

Depth of groove up to
Clamping range

8.2 mm
2 - 2.4 mm

for machines TRAUB (TNL12/7)

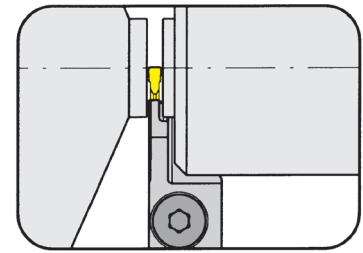

for Indexable insert

Type S124
S224
NS224

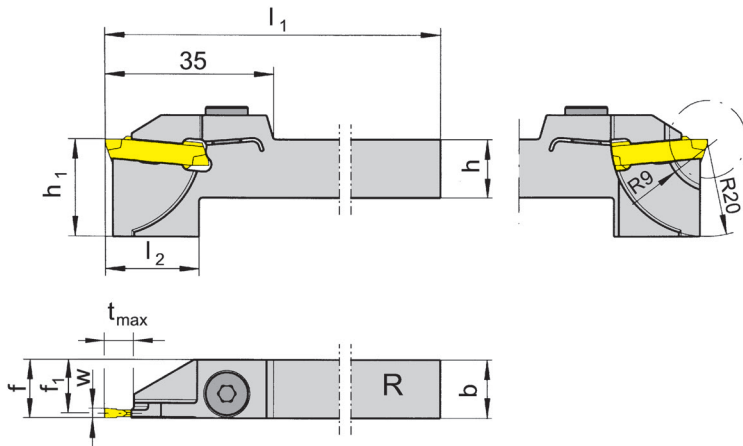

R = right hand version shown

Part number	h	b	l ₁	l ₂	h ₁	f ₁	f	t _{max}	Size	Clamping range
RH224.1212.81	12	12	95	19.5	20	11.1	f ₁ +w/2	8.2	01	2.0 - 2.4

Further sizes upon request

w see indexable inserts

Dimensions in mm

For torque specification of the screw, please see Technical Instructions.

Spare Parts

Toolholder	Clamping Screw	TORX PLUS® Wrench
RH224.1212.81	6.17T25P	T25PQ

Grooving and Side Turning (internal)



Toolholder

B224

Short style
with screwed clamping

Bore \varnothing from
Depth of groove up to
Clamping range

30 mm
8 mm
2 - 6.1 mm

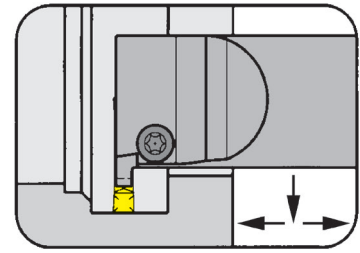

for Indexable insert

Type S124
S224
NS224

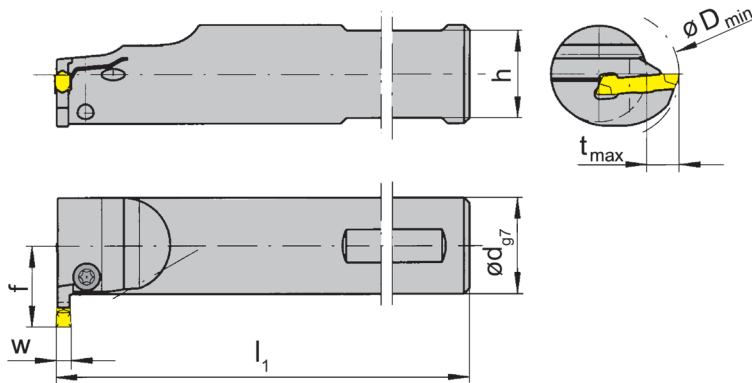

with through coolant supply

R = right hand version shown

L = left hand version

Part number	d	l_1	h	f	t_{max}	D_{min}	Size	Clamping range
R/LB224.0020.0.01	20	130	18	18.5	8	30	01	2.0 - 2.4
R/LB224.0025.0.01	25	130	23	21.0	8	35	01	2.0 - 2.4
R/LB224.0020.0.02	20	130	18	18.5	8	30	02	2.4 - 2.8
R/LB224.0025.0.02	25	130	23	21.0	8	35	02	2.4 - 2.8
R/LB224.0020.0.03	20	130	18	18.5	8	30	03	2.8 - 3.7
R/LB224.0025.0.03	25	130	23	21.0	8	35	03	2.8 - 3.7
R/LB224.0032.0.03	32	150	30	24.5	8	42	03	2.8 - 3.7
R/LB224.0020.0.04	20	130	18	18.5	8	30	04	3.7 - 4.4
R/LB224.0025.0.04	25	130	23	21.0	8	35	04	3.7 - 4.4
R/LB224.0032.0.04	32	150	30	24.5	8	42	04	3.7 - 4.4
R/LB224.0020.0.05	20	130	18	18.5	8	30	05	4.4 - 5.1
R/LB224.0025.0.05	25	130	23	21.0	8	35	05	4.4 - 5.1
R/LB224.0032.0.05	32	150	30	24.5	8	42	05	4.4 - 5.1
R/LB224.0025.0.06	25	130	23	21.0	8	35	06	5.1 - 6.1
R/LB224.0032.0.06	32	150	30	24.5	8	42	06	5.1 - 6.1

State R or L version

w see indexable inserts

Dimensions in mm

Further sizes upon request

For torque specification of the screw, please see Technical Instructions.

Spare Parts

Toolholder	Clamping Screw	TORX PLUS® Wrench
R/LB224...	5.13T20EP	T20PQ

Grooving and Side Turning (internal)



Toolholder

BU224

with screwed clamping

Bore \varnothing from
Depth of groove up to
Clamping range

1.102"
.315"
.079 - .240"

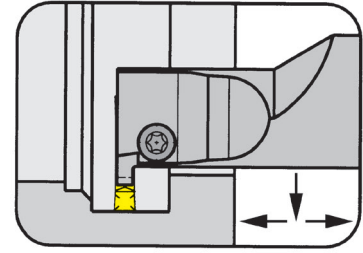

for Indexable insert

Type S124
S224
NS224

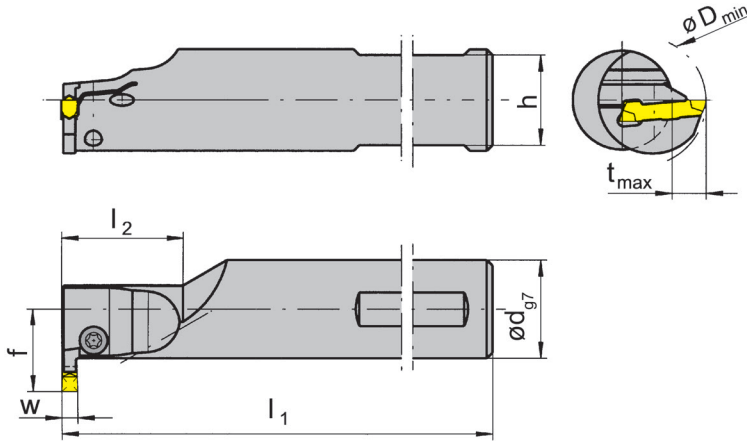

with through coolant supply

R = right hand version shown

L = left hand version

Part number	d	l ₁	l ₂	h	f	t _{max}	D _{min}	Size	Clamping range
R/LBU224.0750.1.01	.750	5.118	1.181	.671	.728	.315	1.102	01	.079 - .094
R/LBU224.1000.1.01	1.000	5.118	1.181	.921	.827	.315	1.102	01	.079 - .094
R/LBU224.0750.1.02	.750	5.118	1.181	.671	.728	.315	1.102	02	.094 - .110
R/LBU224.1000.1.02	1.000	5.118	1.181	.921	.827	.315	1.102	02	.094 - .110
R/LBU224.0750.1.03	.750	5.118	1.181	.671	.728	.315	1.102	03	.110 - .146
R/LBU224.1000.1.03	1.000	5.118	1.181	.921	.827	.315	1.102	03	.110 - .146
R/LBU224.1250.1.03	1.250	6.004	1.181	1.171	.965	.315	1.102	03	.110 - .146
R/LBU224.0750.1.04	.750	5.118	1.181	.671	.728	.315	1.102	04	.146 - .173
R/LBU224.1000.1.04	1.000	5.118	1.181	.921	.827	.315	1.102	04	.146 - .173
R/LBU224.1250.1.04	1.250	6.004	1.181	1.171	.965	.315	1.102	04	.146 - .173
R/LBU224.1000.1.05	1.000	5.118	1.181	.921	.827	.315	1.102	05	.173 - .201
RBU224.0750.1.05	.750	5.118	1.181	.671	.728	.315	1.102	05	.173 - .201
R/LBU224.1000.1.06	1.000	5.118	1.181	.921	.827	.315	1.102	06	.201 - .240

State R or L version

w see indexable inserts

Dimensions in inch

Further sizes upon request

For torque specification of the screw, please see Technical Instructions.

Spare Parts

Toolholder	Clamping Screw	TORX PLUS® Wrench
R/LBU224...	5.13T20EP	T20PQ

Grooving and Side Turning (internal)



Toolholder

B224

with screwed clamping

Bore \varnothing from
Depth of groove up to
Clamping range

28 mm
8 mm
2 - 6.1 mm

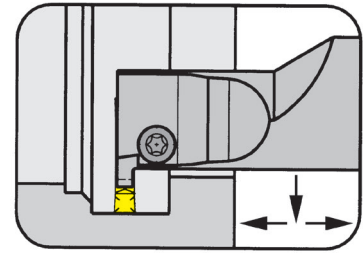

for Indexable insert

Type S124
S224
NS224

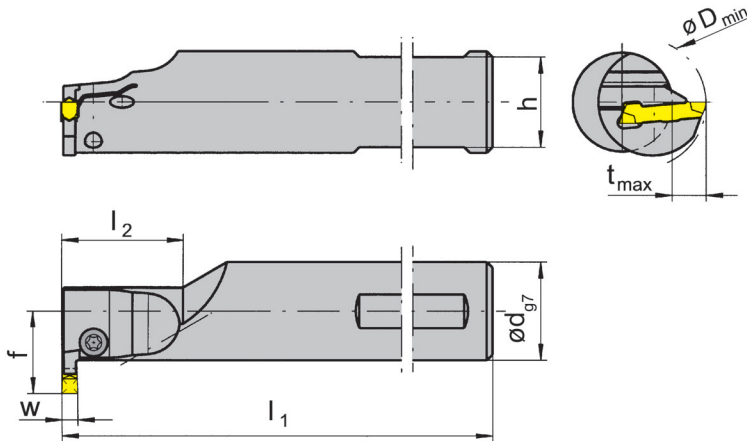

with through coolant supply

R = right hand version shown

L = left hand version

Part number	d	l ₁	l ₂	h	f	t _{max}	D _{min}	Size	Clamping range
R/LB224.0020.1.01	20	130	30	18	18.5	8	28	01	2.0 - 2.4
R/LB224.0025.1.01	25	130	30	23	21.0	8	28	01	2.0 - 2.4
R/LB224.0020.1.02	20	130	30	18	18.5	8	28	02	2.4 - 2.8
R/LB224.0025.1.02	25	130	30	23	21.0	8	28	02	2.4 - 2.8
R/LB224.0020.1.03	20	130	30	18	18.5	8	28	03	2.8 - 3.7
R/LB224.0025.1.03	25	130	30	23	21.0	8	28	03	2.8 - 3.7
R/LB224.0032.1.03	32	150	30	30	24.5	8	28	03	2.8 - 3.7
R/LB224.0020.1.04	20	130	30	18	18.5	8	28	04	3.7 - 4.4
R/LB224.0025.1.04	25	130	30	23	21.0	8	28	04	3.7 - 4.4
R/LB224.0032.1.04	32	150	30	30	24.5	8	28	04	3.7 - 4.4
R/LB224.0025.1.05	25	130	30	23	21.0	8	28	05	4.4 - 5.1
R/LB224.0032.1.05	32	150	30	30	24.5	8	28	05	4.4 - 5.1
R/LB224.0025.1.06	25	130	30	23	21.0	8	28	06	5.1 - 6.1
R/LB224.0032.1.06	32	150	30	30	24.5	8	28	06	5.1 - 6.1

State R or L version

w see indexable inserts

Dimensions in mm

Further sizes upon request

For torque specification of the screw, please see Technical Instructions.

Spare Parts

Toolholder	Clamping Screw	TORX PLUS® Wrench
R/LB224...	5.13T20EP	T20PQ

Grooving and Side Turning (internal)



Toolholder

BU224

with screwed clamping

Bore \varnothing from
Depth of groove up to
Clamping range

1.260"
5.12"
.110 - .240"

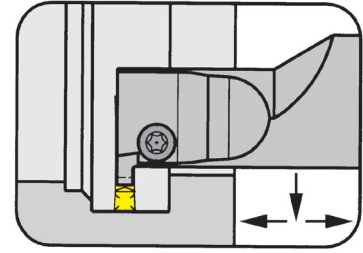

for Indexable insert

Type S124
S224
NS224

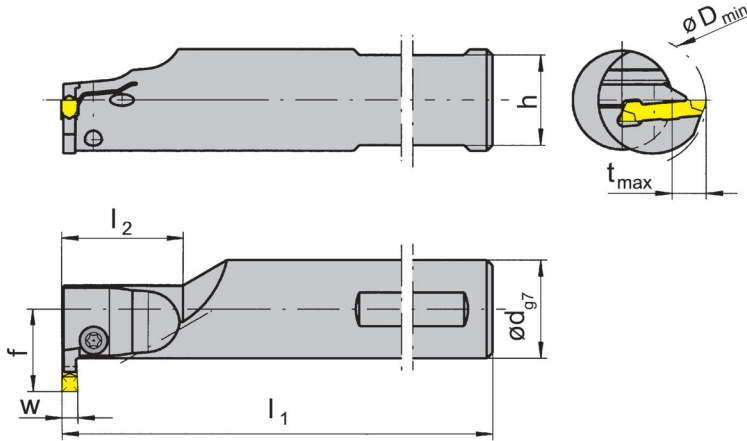

R = right hand version shown

L = left hand version

with through coolant supply

Part number	d	l ₁	l ₂	h	f	t _{max}	D _{min}	Size	Clamping range
R/LBU224.1000.1.13	1.000	5.118	1.181	.921	.925	.394	1.260	03	.110 - .146
R/LBU224.1250.1.13	1.250	6.004	1.181	1.171	1.102	.433	1.260	03	.110 - .146
R/LBU224.1000.1.14	1.000	5.118	1.181	.921	.925	.394	1.260	04	.146 - .173
R/LBU224.1250.1.14	1.250	6.004	1.181	1.171	1.102	.433	1.260	04	.146 - .173
R/LBU224.1250.1.15	1.250	6.004	1.181	1.171	1.102	.433	1.260	05	.173 - .201
R/LBU224.1500.1.25	1.500	7.008	1.181	1.421	1.299	.512	1.496	05	.173 - .201
R/LBU224.1250.1.16	1.250	6.004	1.181	1.171	1.102	.433	1.260	06	.201 - .240
R/LBU224.1500.1.26	1.500	7.008	1.181	1.421	1.299	.512	1.496	06	.201 - .240

State R or L version

w see indexable inserts

Dimensions in inch

Further sizes upon request

For torque specification of the screw, please see Technical Instructions.

Spare Parts

Toolholder	Clamping Screw	TORX PLUS® Wrench
R/LBU224...	5.13T20EP	T20PQ

G30

Call Us Toll Free (888) 818-4676

Grooving and Side Turning (internal)



Toolholder

B224

with screwed clamping

Bore \varnothing from
Depth of groove up to
Clamping range

32 mm
13 mm
2.8 - 6.1 mm

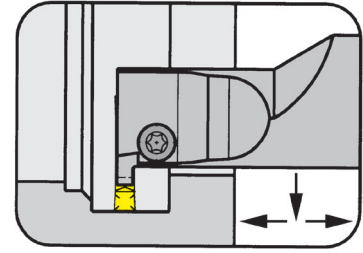

for Indexable insert

Type S124
S224
NS224

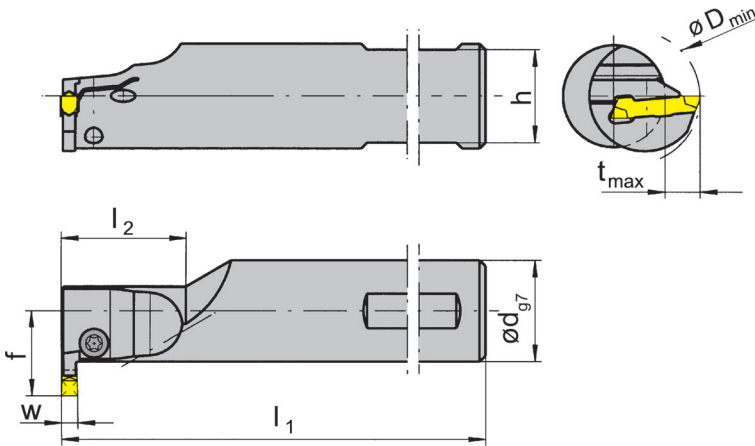

R = right hand version shown

L = left hand version

with through coolant supply

Part number	d	l ₁	l ₂	h	f	t _{max}	D _{min}	Size	Clamping range
R/LB224.0025.1.13	25	130	30	23	23.5	10	32	03	2.8 - 3.7
R/LB224.0032.1.13	32	150	30	30	28.0	11	32	03	2.8 - 3.7
R/LB224.0025.1.14	25	130	30	23	23.5	10	32	04	3.7 - 4.4
R/LB224.0032.1.14	32	150	30	30	28.0	11	32	04	3.7 - 4.4
R/LB224.0032.1.15	32	150	30	30	28.0	11	32	05	4.4 - 5.1
R/LB224.0040.1.25	40	180	30	38	34.0	13	38	05	4.4 - 5.1
R/LB224.0032.1.16	32	150	30	30	28.0	11	32	06	5.1 - 6.1
R/LB224.0040.1.26	40	180	30	38	34.0	13	38	06	5.1 - 6.1

State R or L version

w see indexable inserts

Dimensions in mm

Further sizes upon request

For torque specification of the screw, please see Technical Instructions.

Spare Parts

Toolholder	Clamping Screw	TORX PLUS® Wrench
R/LB224...	5.13T20EP	T20PQ



Grooving and Side Turning (internal)



Toolholder

BU224

with screwed clamping

Bore \varnothing from
Depth of groove up to
Clamping range

1.102"
.433"
.079 - .173"

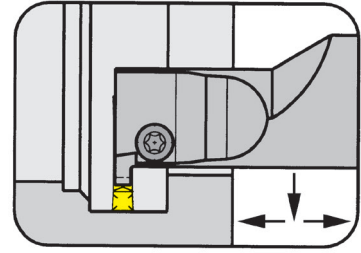

for Indexable insert

Type S124
S224
NS224

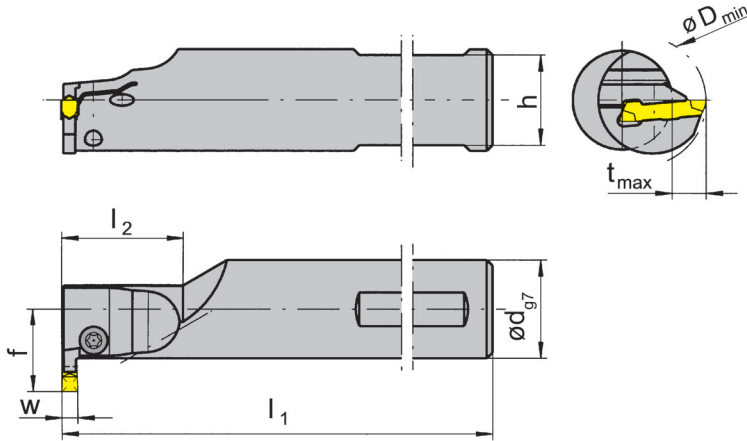

with through coolant supply

R = right hand version shown

L = left hand version

Part number	d	l ₁	l ₂	h	f	t _{max}	D _{min}	Size	Clamping range
R/LBU224.0750.2.01	.750	5.118	1.772	.671	.728	.315	1.102	01	.079 - .094
R/LBU224.1000.2.01	1.000	6.004	1.969	.921	.827	.315	1.102	01	.079 - .094
R/LBU224.0750.2.02	.750	5.118	1.772	.671	.728	.315	1.102	02	.094 - .110
R/LBU224.1000.2.02	1.000	6.004	1.969	.921	.827	.315	1.102	02	.094 - .110
R/LBU224.1000.2.03	1.000	6.004	1.969	.921	.827	.315	1.102	03	.110 - .146
R/LBU224.1250.2.03	1.250	7.008	1.969	1.171	.965	.315	1.102	03	.110 - .146
R/LBU224.1250.2.13	1.250	7.008	1.969	1.171	1.102	.433	1.260	03	.110 - .146
R/LBU224.1000.2.04	1.000	6.004	1.969	.921	.827	.315	1.102	04	.146 - .173
R/LBU224.1250.2.04	1.250	7.008	1.969	1.171	.965	.315	1.102	04	.146 - .173
R/LBU224.1250.2.14	1.250	7.008	1.969	1.171	1.102	.433	1.260	04	.146 - .173

State R or L version

w see indexable inserts

Dimensions in inch

Further sizes upon request

For torque specification of the screw, please see Technical Instructions.

Spare Parts

Toolholder	Clamping Screw	TORX PLUS® Wrench
R/LBU224...	5.13T20EP	T20PQ

Grooving and Side Turning (internal)



Toolholder

B224

with screwed clamping

Bore \varnothing from
Depth of groove up to
Clamping range

28 mm
11 mm
2 - 4.4 mm

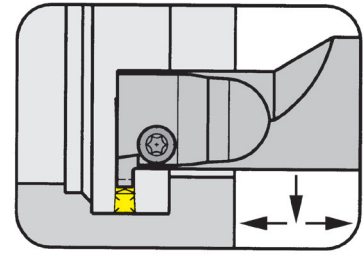

for Indexable insert

Type S124
S224
NS224

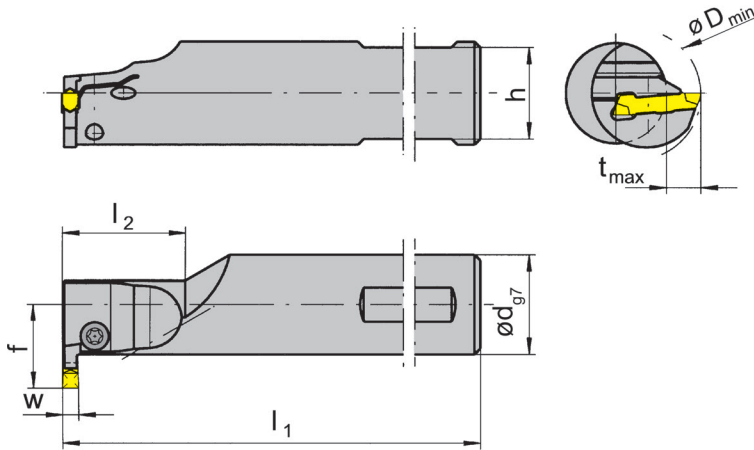

R = right hand version shown

L = left hand version

with through coolant supply

Part number	d	l ₁	l ₂	h	f	t _{max}	D _{min}	Size	Clamping range
R/LB224.0020.2.01	20	130	45	18	18.5	8	28	01	2.0 - 2.4
R/LB224.0025.2.01	25	150	50	23	21.0	8	28	01	2.0 - 2.4
R/LB224.0020.2.02	20	130	45	18	18.5	8	28	02	2.4 - 2.8
R/LB224.0025.2.02	25	150	50	23	21.0	8	28	02	2.4 - 2.8
R/LB224.0025.2.03	25	150	50	23	21.0	8	28	03	2.8 - 3.7
R/LB224.0032.2.03	32	180	50	30	24.5	8	28	03	2.8 - 3.7
R/LB224.0032.2.13	32	180	50	30	28.0	11	32	03	2.8 - 3.7
R/LB224.0025.2.04	25	150	50	23	21.0	8	28	04	3.7 - 4.4
R/LB224.0032.2.04	32	180	50	30	24.5	8	28	04	3.7 - 4.4
R/LB224.0032.2.14	32	180	50	30	28.0	11	32	04	3.7 - 4.4

State R or L version

w see indexable inserts

Dimensions in mm

Further sizes upon request

For torque specification of the screw, please see Technical Instructions.

Spare Parts

Toolholder	Clamping Screw	TORX PLUS® Wrench
R/LB224...	5.13T20EP	T20PQ

Basic toolholder

BU224

without cassette

Bore \varnothing from
Depth of groove up to
Width of groove up to

1.575"
.433"
.240"

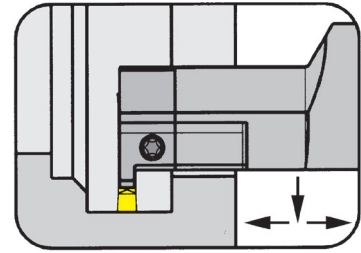

for Cassette

Type BK224

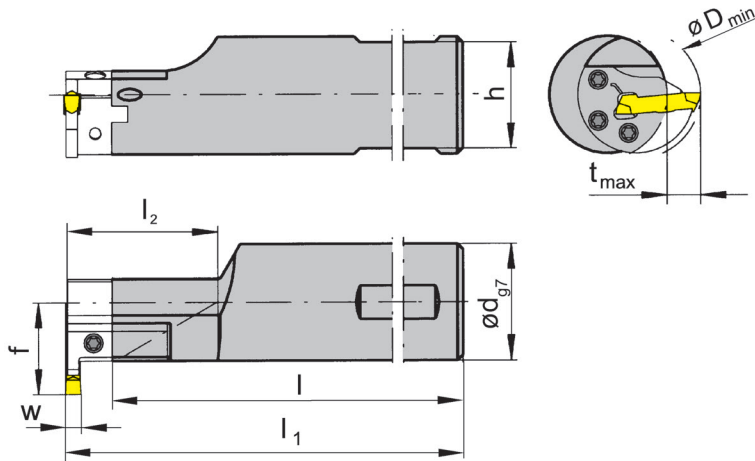

R = right hand version shown

L = left hand version

with through coolant supply

Part number	l_1	d	l	l_2	h	f
R/LBU224.1250.1.K2	$l+b_1+w/2$	1.250	5.465	1.181	1.171	1.102
R/LBU224.1250.2.K2	$l+b_1+w/2$	1.250	6.469	2.362	1.171	1.102
R/LBU224.1500.1.K2	$l+b_1+w/2$	1.500	6.469	1.181	1.421	1.220
R/LBU224.1500.2.K2	$l+b_1+w/2$	1.500	7.453	2.362	1.421	1.220

State R or L version

Dimensions in inch

Further sizes upon request

Note:

Dimensions for D_{min} , t_{max} and b_1 see cassettes

Spare Parts

Basic toolholder	Clamping Screw	TORX PLUS® Wrench
R/LBU224...	030.0518.T20P	T20PQ

Grooving and Side Turning (internal)



Basic toolholder

B224

without cassette

Bore \varnothing from
Depth of groove up to
Clamping range

40 mm
11 mm
2 - 6.1 mm

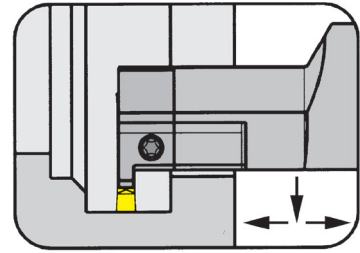

for Cassette

Type BK224

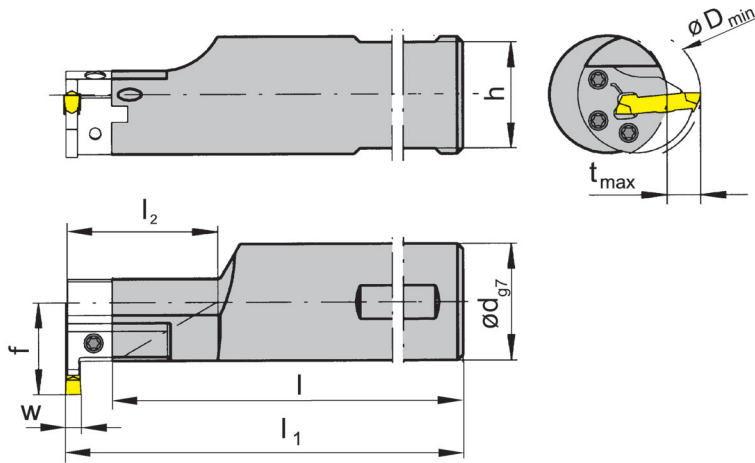

R = right hand version shown

L = left hand version

with through coolant supply

Part number	l_1	d	l	l_2	h	f
R/LB224.0032.1.K2	$l+b_1+w/2$	32	136.3	30	30	28
R/LB224.0032.2.K2	$l+b_1+w/2$	32	166.3	60	30	28
R/LB224.0040.1.K2	$l+b_1+w/2$	40	166.3	30	38	32
R/LB224.0040.2.K2	$l+b_1+w/2$	40	186.3	60	38	32

State R or L version

w see indexable inserts

Dimensions in mm

Further sizes upon request

Note:

Dimensions for D_{min} , t_{max} and b_1 see cassettes

Spare Parts

Basic toolholder	Clamping Screw	TORX PLUS® Wrench
R/LB224...	030.0518.T20P	T20PQ



Grooving and Side Turning (internal)



Basic toolholder

B224

without cassette

Bore \varnothing from
Depth of groove up to
Clamping range

40 mm
11 mm
2 - 6.1 mm

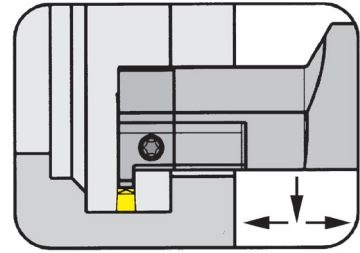

for Cassette

Type BK224

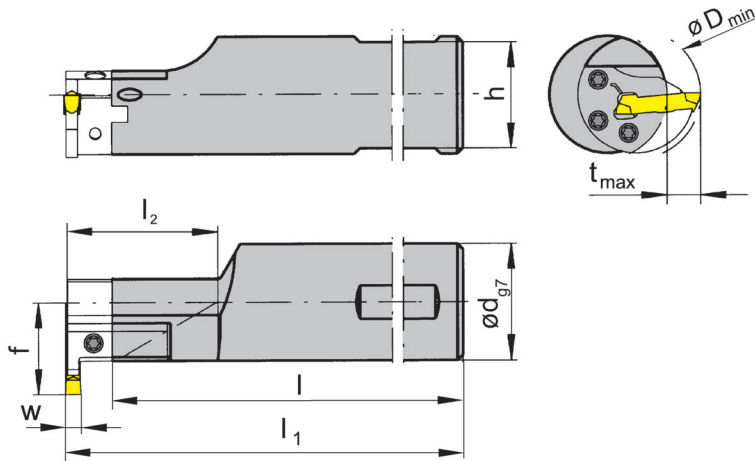

R = right hand version shown

L = left hand version

with through coolant supply

Part number	l_1	d	l	l_2	h	f
R/LB224.0032.1.K2.IK	$l+b_1+w/2$	32	136.6	30	30	28
R/LB224.0032.2.K2.IK	$l+b_1+w/2$	32	166.3	60	30	28
R/LB224.0040.1.K2.IK	$l+b_1+w/2$	40	136.3	30	38	32
R/LB224.0040.2.K2.IK	$l+b_1+w/2$	40	166.3	60	38	32

State R or L version

w see indexable inserts

Dimensions in mm

Further sizes upon request

Note:

Dimensions for D_{min} , t_{max} and b_1 see cassettes

Spare Parts

Basic toolholder	Clamping Screw	TORX PLUS® Wrench
R/LB224...	030.0518.T20P	T20PQ

Cassette

BK224

with screwed clamping

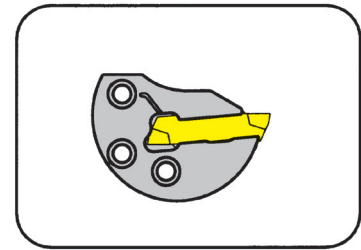

Bore \varnothing from
Depth of groove up to
Clamping range

40 mm
11 mm
2 - 6.1 mm

for Indexable insert

Type S124
S224
NS224

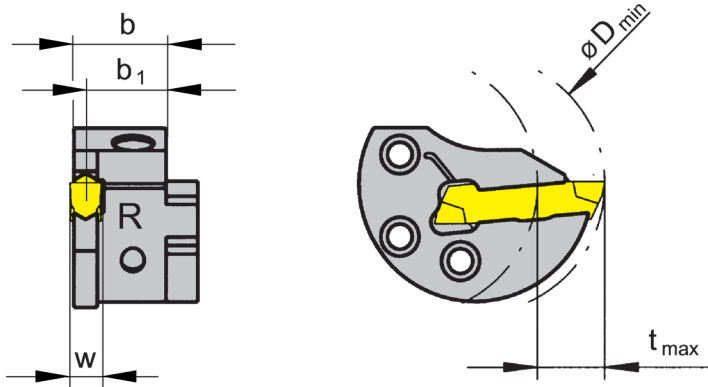

R = right hand version shown

L = left hand version

Part number	D_{min}	t_{max}	b	b_1	Size	Clamping range
R/LBK224.0040.01	40	11	13.40	12.70	01	2.0 - 2.4
R/LBK224.0040.02	40	11	13.35	12.45	02	2.4 - 2.8
R/LBK224.0040.03	40	11	13.30	12.20	03	2.8 - 3.7
R/LBK224.0040.04	40	11	13.15	11.70	04	3.7 - 4.4
R/LBK224.0040.05	40	11	13.05	11.20	05	4.4 - 5.1
R/LBK224.0040.06	40	11	12.95	10.70	06	5.1 - 6.1

State R or L version

w see indexable inserts

Dimensions in mm

Use right hand cassettes in right hand basic toolholders and left hand cassettes in left hand basic toolholders.

Ordering note:

The fastening screw is combined with the basic toolholder - no separate order required.

For torque specification of the screw, please see Technical Instructions.

Spare Parts

Cassette	Clamping Screw	TORX PLUS® Wrench
R/LBK224...	5.13T20EP	T20PQ



Cassette

BK224

with screwed clamping

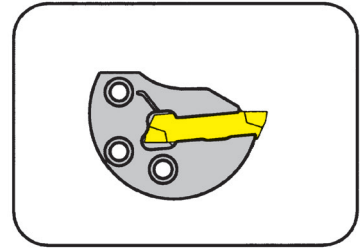

Bore \varnothing from
Depth of groove up to
Clamping range

40 mm
11 mm
2 - 6.1 mm

for Indexable insert

Type S124
S224
NS224

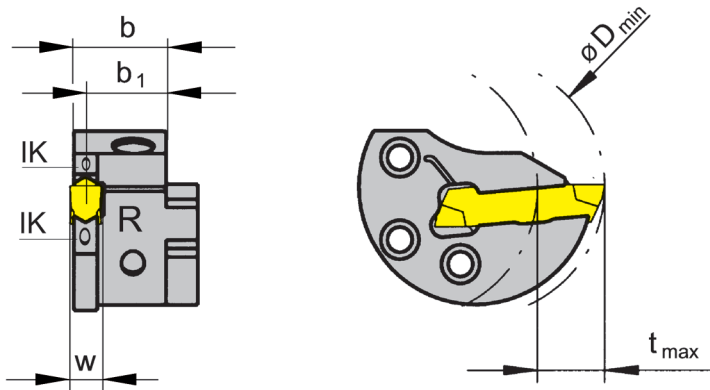

with through coolant supply

R = right hand version shown

L = left hand version

Part number	D_{min}	t_{max}	b	b_1	Size	Clamping range
R/LBK224.0040.01.IK	40	11	13.50	12.70	01	2.0 - 2.4
R/LBK224.0040.02.IK	40	11	13.45	12.45	02	2.4 - 2.8
R/LBK224.0040.03.IK	40	11	13.40	12.20	03	2.8 - 3.7
R/LBK224.0040.04.IK	40	11	13.35	11.70	04	3.7 - 4.4
R/LBK224.0040.05.IK	40	11	13.20	11.20	05	4.4 - 5.1
R/LBK224.0040.06.IK	40	11	13.05	10.70	06	5.1 - 6.1

State R or L version

w see indexable inserts

Dimensions in mm

Use right hand cassettes in right hand basic toolholders and left hand cassettes in left hand basic toolholders.

Ordering note:

The fastening screw is combined with the basic toolholder - no separate order required.

For torque specification of the screw, please see Technical Instructions.

Spare Parts

Cassette	Clamping Screw	TORX PLUS® Wrench	Threaded Pin
R/LBK224.0040.01/02.IK	5.13T20EP	T20PQ	
R/LBK224.0040.03/04.IK	5.13T20EP	T20PQ	2.03.913
R/LBK224.0040.04/05.IK	5.13T20EP	T20PQ	3.03.913

Grooving Corner Reliefs (internal)



Toolholder

BU224

with screwed clamping

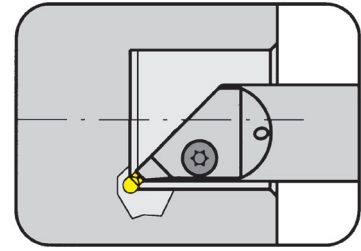

Width of groove	.110 - .173"
-----------------	--------------

for Indexable insert

Type S224...K

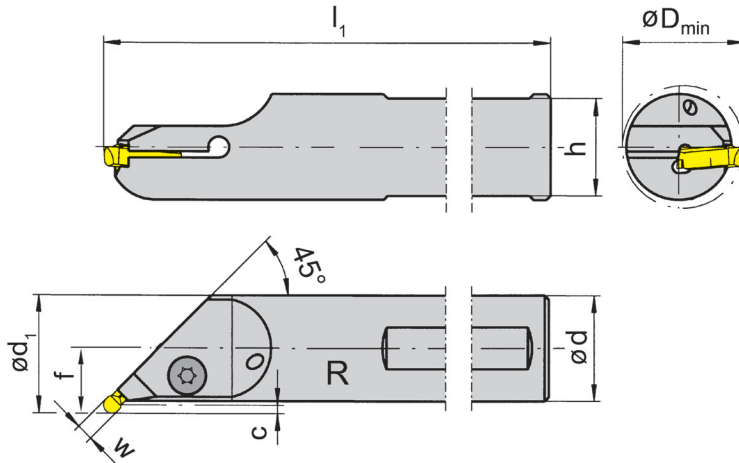

R = right hand version shown

L = left hand version

only for full radius inserts
S224...K

Part number	d	h	l ₁	f	C	D _{min}	d ₁	Width of groove
RBU224.4510.0.04	1.000	.925	6.004	.618	.098	1.157	1.118	.110 - .173

State R or L version

w see indexable inserts

Dimensions in inch

Further sizes upon request

For torque specification of the screw, please see Technical Instructions.

Spare Parts

Toolholder	Clamping Screw	TORX PLUS® Wrench
RBU224.4510.0.04	6.14T25P	T25PQ



Grooving Corner Reliefs (internal)



Toolholder

B224

with screwed clamping

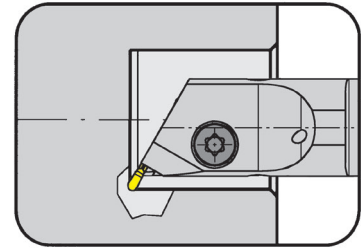

Width of groove 2.0 - 6.1 mm

for Indexable insert

Type S224...K

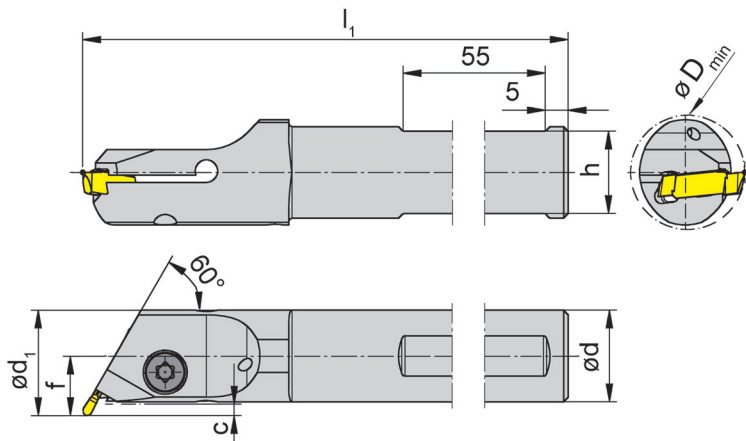

only for full radius inserts
S224...K

R = right hand version shown

L = left hand version

Part number	d	h	l_1	f	C	D_{min}	d_1	Width of groove
R/LB224.6020.0.02	20	18	150	13.0	2.5	25.0	23.0	2.0 - 2.8
R/LB224.6025.0.02	25	23	150	15.5	2.5	29.0	28.0	2.0 - 2.8
R/LB224.6032.0.02	32	30	150	19.0	2.5	36.0	35.0	2.0 - 2.8
R/LB224.6020.0.04	20	18	150	13.0	2.5	25.0	23.0	2.8 - 4.4
R/LB224.6025.0.04	25	23	150	15.5	2.5	29.0	28.0	2.8 - 4.4
R/LB224.6032.0.04	32	30	150	19.0	2.5	36.0	35.0	2.8 - 4.4
R/LB224.6020.0.06	20	18	150	13.5	3.0	25.0	23.5	4.4 - 6.1
R/LB224.6025.0.06	25	23	150	16.0	3.0	29.5	28.5	4.4 - 6.1
R/LB224.6032.0.06	32	30	150	19.5	3.0	36.5	35.5	4.4 - 6.1

State R or L version

Dimensions in mm

Further sizes upon request

For torque specification of the screw, please see Technical Instructions.

Revision factor Δl_1 , Δc and Δf in relation to radius r

r	Δl_1	Δc	Δf
3,0	0	0	0
2,5	-0,146	-0,146	-0,146
2,0	0	0	0
1,5	-0,146	-0,146	-0,146
1,0	0	0	0

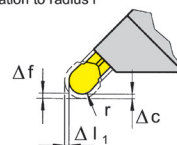

Spare Parts

Toolholder	Clamping Screw	TORX PLUS® Wrench
R/LB224...	6.14T25P	T25PQ

G40

Call Us Toll Free (888) 818-4676

Grooving Corner Reliefs (internal)



Toolholder

B224

with screwed clamping

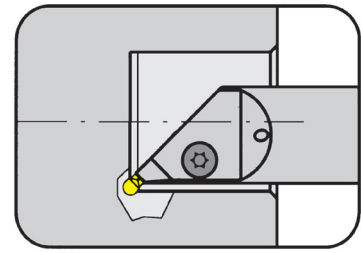

Width of groove 2.0 - 6.1 mm

for Indexable insert

Type S224...K

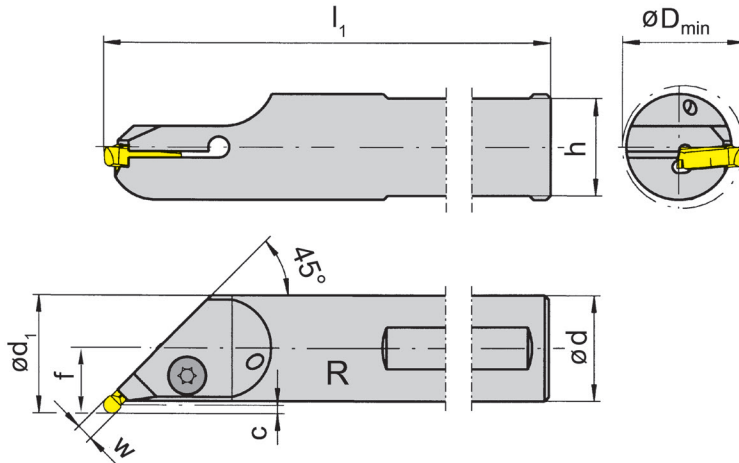

R = right hand version shown

L = left hand version

only for full radius inserts
S224...K



Part number	d	h	l ₁	f	C	D _{min}	d ₁	Width of groove
R/LB224.4520.0.02	20	18	130	13.0	2.5	25.0	23.0	2.0 - 2.8
R/LB224.4525.0.02	25	23	150	15.5	2.5	29.0	28.0	2.0 - 2.8
R/LB224.4532.0.02	32	30	150	19.0	2.5	36.0	35.0	2.0 - 2.8
R/LB224.4540.1.02	40	38	200	23.0	2.5	44.0	43.0	2.0 - 2.8
R/LB224.4520.0.04	20	18	130	13.0	2.5	25.0	23.0	2.8 - 4.4
R/LB224.4525.0.04	25	23	150	15.5	2.5	29.0	28.0	2.8 - 4.4
R/LB224.4532.0.04	32	30	150	19.0	2.5	36.0	35.0	2.8 - 4.4
R/LB224.4540.1.04	40	38	200	23.0	2.5	44.0	43.0	2.8 - 4.4
R/LB224.4520.0.06	20	18	130	13.5	3.0	25.0	23.5	4.4 - 6.1
R/LB224.4525.0.06	25	23	150	16.0	3.0	29.5	28.5	4.4 - 6.1
R/LB224.4532.0.06	32	30	150	19.0	3.0	36.5	35.5	4.4 - 6.1

State R or L version

w see indexable inserts

Dimensions in mm

Further sizes upon request

For torque specification of the screw, please see Technical Instructions.

Revision factor Δl_1 , Δc and Δf in relation to radius r

r	Δl_1	Δc	Δf
3,0	0	0	0
2,5	-0,146	-0,146	-0,146
2,0	0	0	0
1,5	-0,146	-0,146	-0,146
1,0	0	0	0

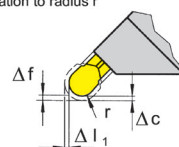

Spare Parts

Toolholder	Clamping Screw	TORX PLUS® Wrench
R/LB224...	6.14T25P	T25PQ

Indexable insert

S224...3.

precision sintered



Geometry .3.

Geometry with chip forming for all materials.

Characteristics

- Excellent swarf control
- Suitable for high alloy - high strength steel
- Reduced swarf width gives high flank surface finish
- Excellent swarf control allows production security

Applications

- Grooving: Depth of groove up to 18 mm
- Side turning: Depth of cut a_p 3 mm*

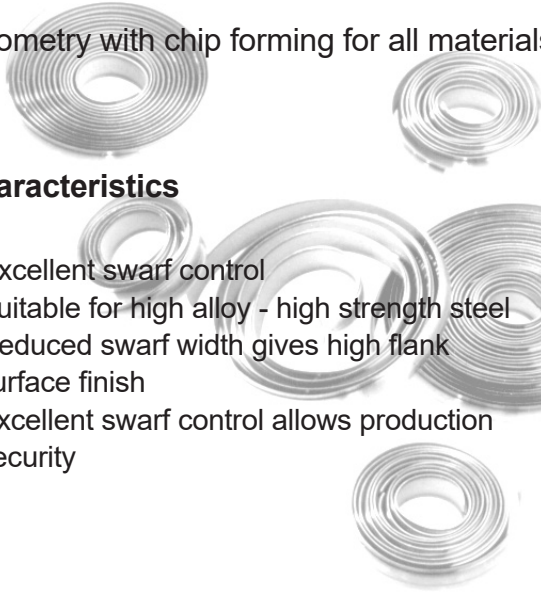
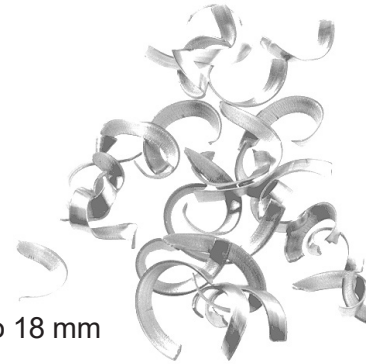

G

Feed rate f

- Grooving: 0.15 to 0.25 mm/rev*
- Side turning: up to 0.4 mm/rev*

* dependent upon width of insert

Indexable inserts with profiles, intermediate sizes or other edge radii are available upon request. Indexable inserts can be used in **right and left hand** toolholders.

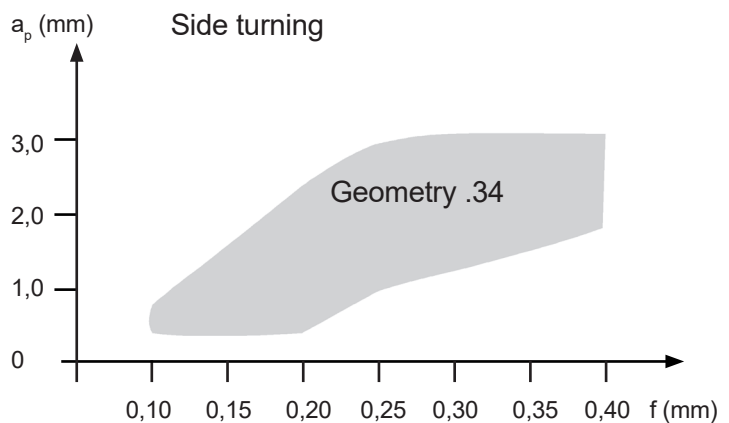

Chip control graph S224.0500.34 material 16MnCr5

Indexable insert

S224

with chip former

Depth of groove up to
Width of groove

.709"
.118 - .236"

precision sintered

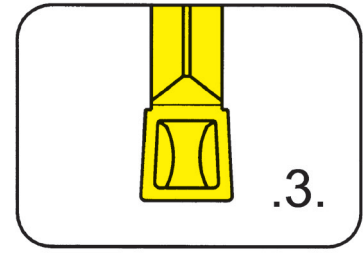

for Toolholder

Type H224
HU224
B224
BU224
BK224

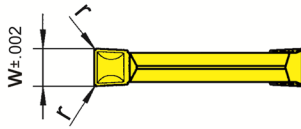
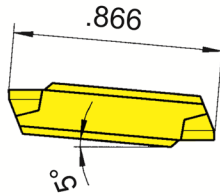

Indexability length $\pm .002''$

Part number	w	r	Size	AL96	AS62	AS66	H54	TC92	TF45	TI22	TI25	TN32	TN35
S224.0300.32	.118	.008	03	▲	▲	▲	x	▲	▲	▲	▲	▲	▲
S224.0300.34	.118	.016	03	▲	▲	▲	x	Δ	▲	x	▲	▲	▲
S224.0400.32	.157	.008	04	x	▲	▲	x	▲	▲	x	▲	▲	▲
S224.0400.34	.157	.016	04	▲	▲	▲	x	▲	▲	▲	▲	▲	▲
S224.0500.34	.197	.016	05	▲	▲	▲	x	▲	▲	▲	▲	▲	▲
S224.0500.38	.197	.031	05	x	▲	▲	x	x	▲		▲	x	▲
S224.0600.34	.236	.016	06	x	▲	▲	x	x	▲		▲	▲	▲
S224.0600.38	.236	.031	06	x	▲	Δ	x	x	▲		x	x	▲
				P	•	•	•	•	•	•	•	•	•
				M	-	-	o	•	-	•	-	-	•
				K	•	-	•	-	-	•	-	-	•
				N	•	-	•	-	-	•	-	-	•
				S	-	-	o	-	-	•	-	-	•
				H	-	-	-	-	-	-	-	-	-

▲ on stock Δ 4 weeks x upon request
 • recommended
 o alternative recommendation
 - not suitable
 uncoated grades
 coated grades
 brazed/Cermet

Dimensions in inch

Carbide grades

Indexable inserts can be used in right and left hand toolholders.



Indexable insert

S224...5.

precision sintered



Geometry .5.

Easy cutting geometry for materials with medium strength.

Characteristics

- Excellent swarf on a wide feed range
- Easy cutting - low power requirement
- Reduced swarf width produces high flank surface finish
- Excellent swarf control allows production security

Applications

- Grooving: Depth of groove up to 18 mm
- Side turning: Depth of cut a_p up to 3 mm*

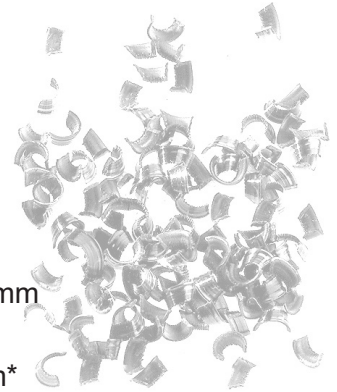

G

Feed rate f

- Grooving: up to 0.45 mm/rev*
- Side turning: up to 0.6 mm/rev*

* dependent upon width of insert

Indexable inserts with profiles, intermediate sizes or other edge radii are available upon request. Indexable inserts can be used in **right and left hand** toolholders.

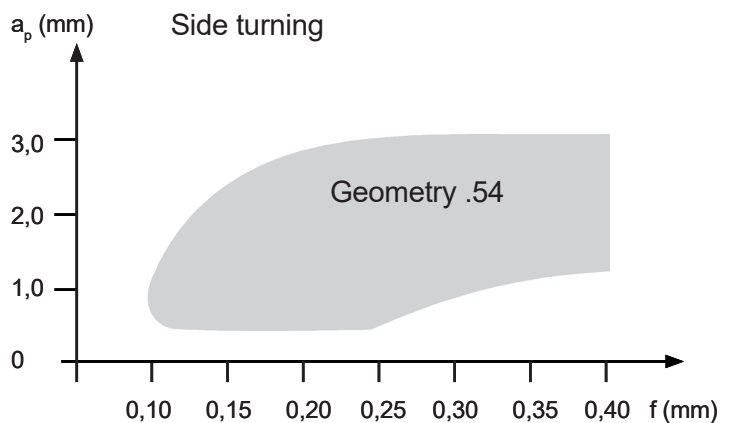

Chip control graph S224.0500.54 material 16MnCr5

Indexable insert

S224

with chip forming

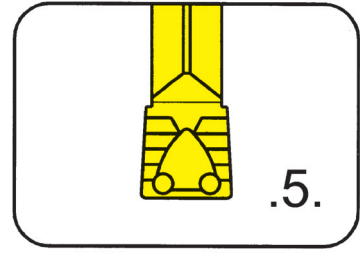

Depth of groove up to
Width of groove

.709"
.079 - .236"

precision sintered

for Toolholder

Type H224
HU224
B224
BU224
BK224

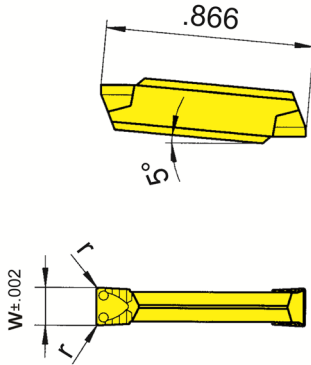

Indexability length ± .002"

Part number	w	r	Size	Carbide grades										
				AL96	AS62	AS66	EG56	H54	TC92	TF45	TI25	TN32	TN35	
S224.0200.52	.079	.008	01		▲	▲	▲	▲						
S224.0250.52	.098	.008	02		▲	▲	▲	▲						
S224.0300.52	.118	.008	03	x	▲	▲	▲	▲	x	▲	▲	▲	▲	▲
S224.0300.54	.118	.016	03	▲	▲	▲	▲	x	▲	▲	▲	▲	▲	▲
S224.0400.52	.157	.008	04	▲	▲	▲	▲	x	▲	▲	▲	▲	▲	▲
S224.0400.54	.157	.016	04	▲	▲	▲	▲	x	▲	▲	▲	▲	▲	▲
S224.0500.54	.197	.016	05	x	▲	▲	▲	x	▲	▲	▲	▲	▲	▲
S224.0500.58	.197	.031	05	▲	▲	▲	▲	x	▲	x	▲	x	x	x
S224.0600.54	.236	.016	06	x	▲	▲	▲	x	▲	▲	▲	x	x	▲
S224.0600.58	.236	.031	06	x	▲	▲	▲	x	x	x	x	x	x	x
P	●	●	●	●	●	●	●	●	●	●	●	●	●	●
M	-	-	○	○	●	-	●	●	-	●	-	-	-	●
K	●	-	●	○	-	-	●	●	-	●	-	-	-	●
N	●	-	●	-	-	-	●	●	-	●	-	-	-	●
S	-	-	○	-	-	-	●	●	-	●	-	-	-	●
H	-	-	-	-	-	-	-	-	-	-	-	-	-	-

▲ on stock Δ 4 weeks x upon request

● recommended

○ alternative recommendation

- not suitable

uncoated grades

coated grades

brazed/Cermet

Dimensions in inch

Carbide grades

Indexable inserts can be used in right and left hand toolholders.



Indexable insert

S224...A.

precision sintered



Geometry .A.

Geometry with excellent chip breaking for materials with medium strength

Characteristics

- Excellent swarf on a wide feed range
- Excellent swarf control in partial cutting
- Reduced swarf width gives high flank surface finish
- Excellent swarf control allows production security

Applications

- Grooving: Depth of groove up to 18 mm
- Side turning: Depth of cut a_p up to 2.5 mm*

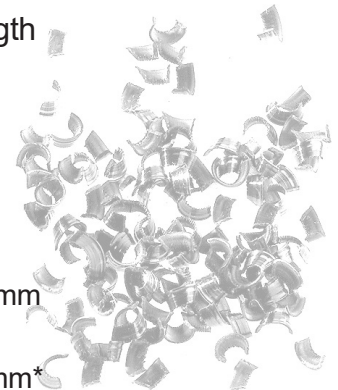

G

Feed rate f

- Grooving: up to 0.3 mm/rev*
- Side turning: up to 0.3 mm/rev*

* dependent upon width of insert

Indexable inserts with profiles, intermediate sizes or other edge radii are available upon request. Indexable inserts can be used in **right and left hand** toolholders.

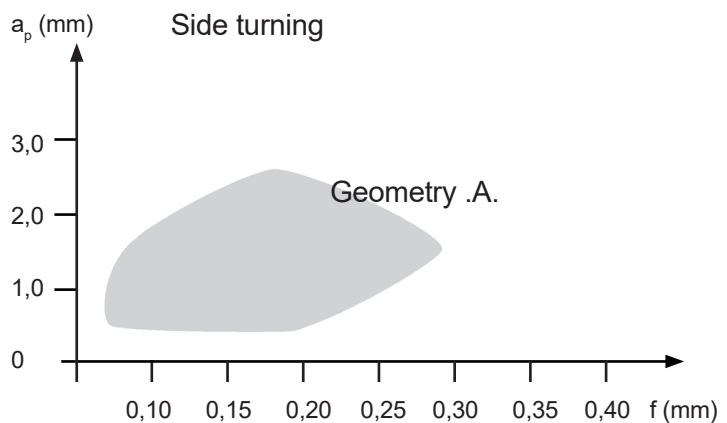

Chip control graph S224.0500.A4 material 16MnCr5

Indexable insert

S224

with chip forming

Depth of groove up to
Width of groove

.709"
.118 - .236"

precision sintered

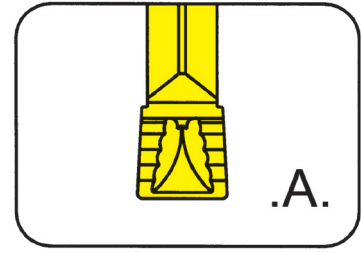

for Toolholder

Type H224
HU224
B224
BU224
BK224

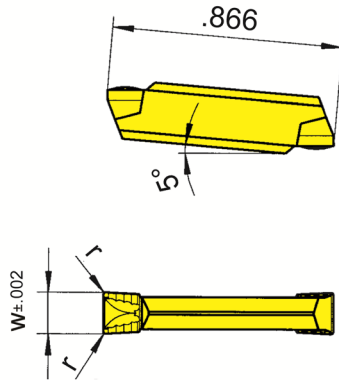

Indexability length $\pm .002''$



Part number	w	r	Size	Carbide grades								
				AL96	AS62	AS65	TC92	TF45	TI22	TI25	TN32	TN35
S224.0300.A2	.118	.008	03	▲	▲		x	▲	▲	▲	▲	▲
S224.0300.A4	.118	.016	03	x	▲		▲	▲	▲	▲	▲	▲
S224.0400.A2	.157	.008	04	x	▲		x	▲	x	▲	▲	▲
S224.0400.A4	.157	.016	04	x	▲	▲	▲	▲	x	▲	▲	▲
S224.0500.A4	.197	.016	05	x	▲		▲	▲	x	▲	▲	▲
S224.0500.A8	.197	.031	05	x	▲		x	x		x	▲	x
S224.0600.A4	.236	.016	06	x	▲		x	x		▲	▲	▲
S224.0600.A8	.236	.031	06	x	▲		x	x		x	x	▲
				P	●	●	●	●	●	●	●	●
				M	-	-	o	-	●	-	-	●
				K	●	-	o	-	●	-	-	●
				N	●	-	-	-	●	-	-	●
				S	-	-	-	-	●	-	-	●
				H	-	-	-	-	-	-	-	-

▲ on stock Δ 4 weeks x upon request
● recommended
o alternative recommendation
- not suitable
■ uncoated grades
■ coated grades
■ brazed/Cermet

Dimensions in inch

Carbide grades

Indexable inserts can be used in right and left hand toolholders.

Indexable insert

S224...D.

precision sintered

Geometry .D.



Easy cutting geometry with chip former.

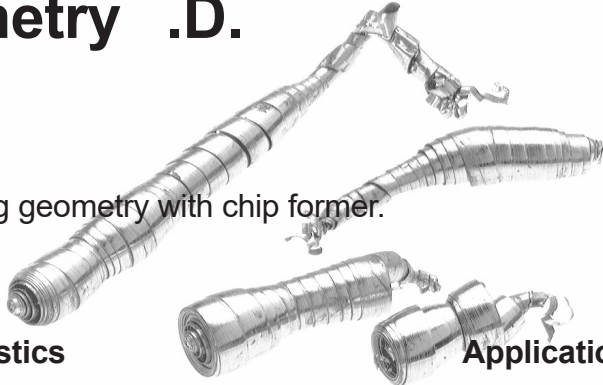

Characteristics

- Mainly used for internal grooving
- Very positive geometry
- Reduced swarf width produces high flank surface finish
- Reduced swarf even at low feedrate

Applications

- Grooving:
Depth of groove up to 18 mm
- Side turning:
Depth of cut a_p up to 3 mm*



Feed rate f

- Grooving: up to 0.15 mm/rev*
- Side turning: up to 0.2 mm/rev*

* dependent upon width of insert

G

Indexable inserts with profiles, intermediate sizes or other edge radii are available upon request. Indexable inserts can be used in **right and left hand** toolholders.

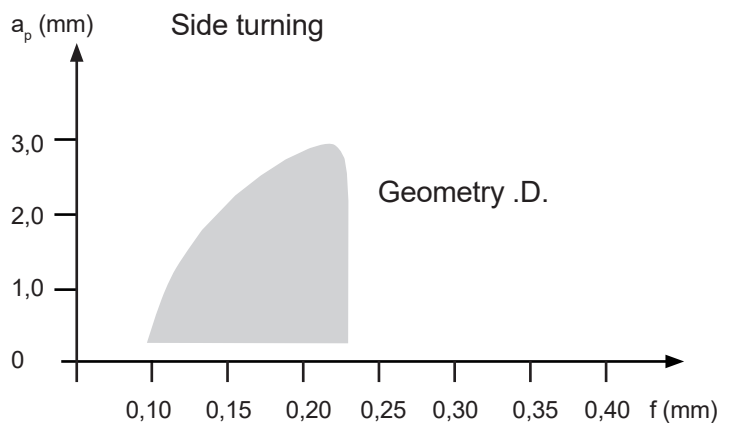

Chip control graph S224.0300.D2 material 16MnCr5

Indexable insert

S224

with chip forming

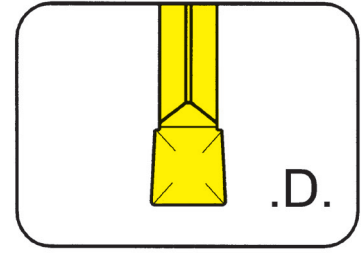

Depth of groove up to	.709"
Width of groove	.079 - .157"

D2 precision sintered / *D2.G precision ground

for Toolholder

- Type
- H224
 - HU224
 - B224
 - BU224
 - BK224

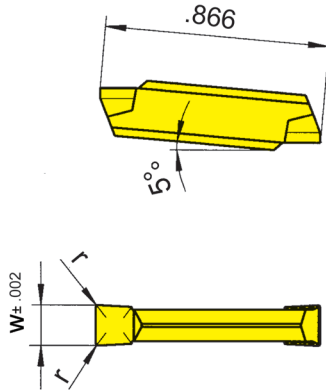

Indexability length ± .002"



Part number	w	r	Size	H54	TF45	TF46	T122	T125	TN32	TN35
S224.0200.D2	.079	.008	01	▲	▲	▲	▲	▲	▲	▲
S224.0200.D2.G	.079	.008	01		x	▲	▲	▲	▲	▲
S224.0250.D2	.098	.008	02	x	▲	▲	▲	▲	▲	▲
S224.0250.D2.G	.098	.008	02			▲	▲	▲	▲	▲
S224.0300.D2	.118	.008	03	▲	▲	▲	▲	▲	▲	▲
S224.0300.D2.G	.118	.008	03		▲	▲	▲	▲	▲	▲
S224.0400.D2	.157	.008	04	x	▲	▲	▲	▲	▲	▲
S224.0400.D2.G	.157	.008	04			▲	▲			
				P	•	•	•	•	•	•
				M	•	•	o	-	•	-
				K	-	•	•	-	•	-
				N	-	•	•	-	•	-
				S	-	•	o	-	•	-
				H	-	-	-	-	-	-

- ▲ on stock Δ 4 weeks x upon request
- recommended
- o alternative recommendation
- not suitable
- uncoated grades
- coated grades
- brazed/Cermet

Dimensions in inch

Carbide grades

Indexable inserts can be used in right and left hand toolholders.

Indexable insert

S224...C.

precision sintered

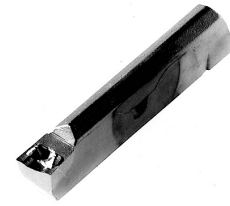

Geometry .C.

Geometry for parting off.

Characteristics

- Excellent swarf control on the recommended feed range
- Reduced swarf width produces high flank surface finish
- Excellent swarf control allows production security

Applications

- Grooving and Parting off:
Depth of groove up to 18 mm

G

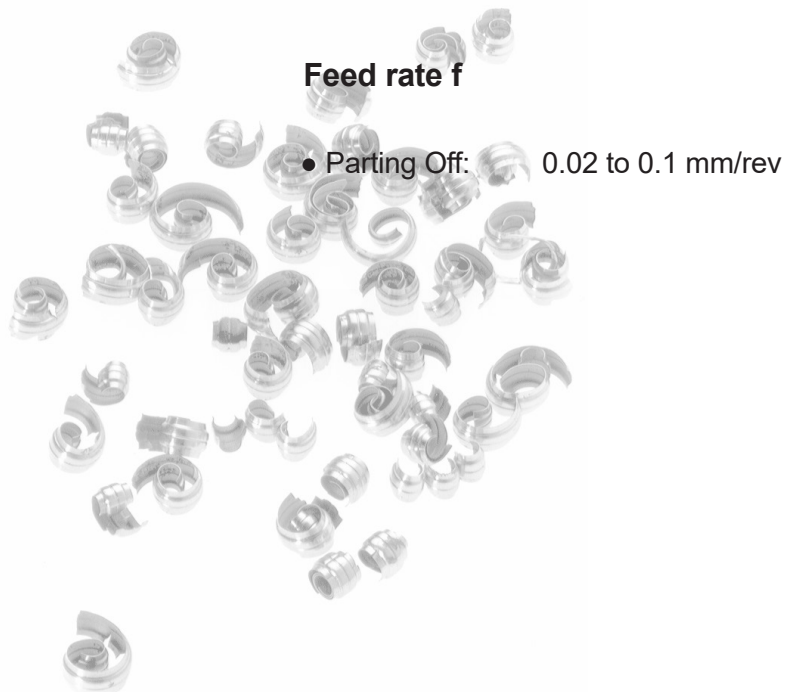

Please note:

The recommended feedrate has to be reduced by 20-50% with right or left hand inserts. Best tool life and surfaces will be obtained with neutral inserts. Reduce the feed rate before parting off when machining solid bars.

Indexable insert

S224

with chip forming

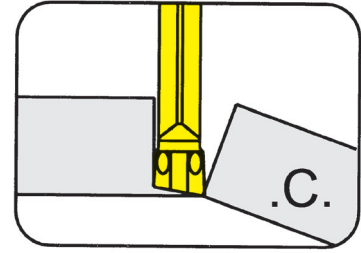

Depth of groove up to	.709"
Width of groove	.079 - .118"

precision sintered

for Toolholder

Type H224
HU224
B224
BU224
BK224

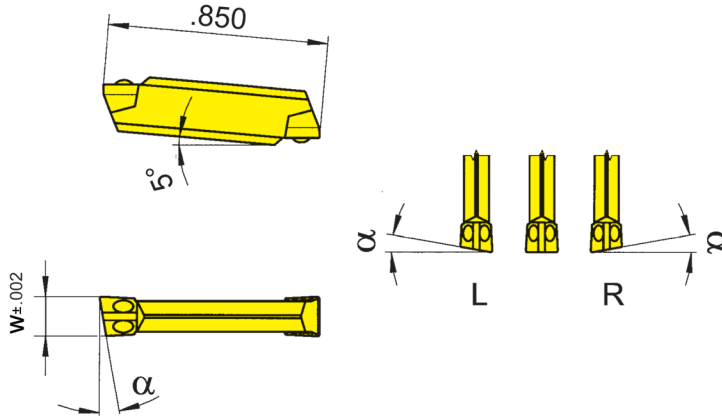

R = right hand version shown

L = left hand version

Indexability length ± .002"

Part number	w	r	α	Size	Carbide grades			
					TC92	TF45	TI25	TN35
S224.0020.C1	.079	.006	0°	01	▲	▲	▲	▲
R/LS224.0520.C1	.079	.006	5°	01	x/x	▲/▲		▲/▲
R/LS224.0820.C1	.079	.006	8°	01	x/x	▲/Δ		x/x
R/LS224.1520.C1	.079	.006	15°	01	x/x	▲/Δ		▲/▲
S224.0025.C1	.098	.006	0°	02	x	▲	▲	▲
R/LS224.0525.C1	.098	.006	5°	02	x/x	▲/▲		▲/Δ
R/LS224.0825.C1	.098	.006	8°	02	x/x	▲/▲		x/x
S224.0030.C1	.118	.006	0°	03	▲	▲	▲	▲
R/LS224.0530.C1	.118	.006	5°	03	x/x	▲/Δ		▲/▲
R/LS224.0830.C1	.118	.006	8°	03	x/x	▲/▲		▲/▲

▲ on stock Δ 4 weeks x upon request

● recommended

○ alternative recommendation

- not suitable

■ uncoated grades

■ coated grades

■ brazed/Cermet

Dimensions in inch

State R or L version

Further sizes upon request

Indexable inserts can be used in right and left hand toolholders.

P	●	●	●	●
M	-	●	●	●
K	-	●	●	●
N	-	●	●	●
S	-	●	●	●
H	-	-	-	-

Carbide grades



Indexable insert

S224

with chip forming

Depth of groove up to	.709"
Width of groove	.118"

ZG precision ground

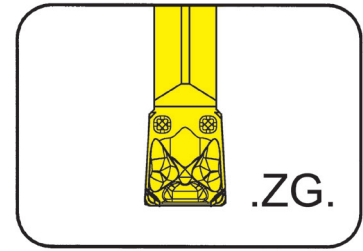

for Toolholder

Type H224
HU224
B224
BU224
BK224

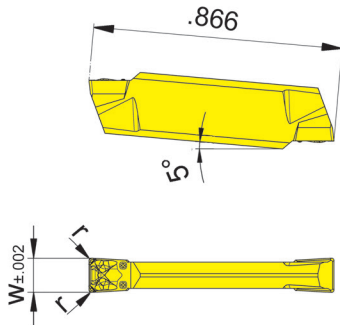

Indexability length ± .002"



Part number	w	r	Size	ALXT
S224.0300.ZG2	.118	.008	03	▲
				P ●
				M ○
				K -
				N -
				S -
				H -

▲ on stock Δ 4 weeks x upon request
● recommended
○ alternative recommendation
- not suitable
□ uncoated grades
■ coated grades
■ brazed/Cermet
Dimensions in inch

Carbide grades

Indexable inserts can be used in right and left hand toolholders.

Indexable insert

S224

with chip former

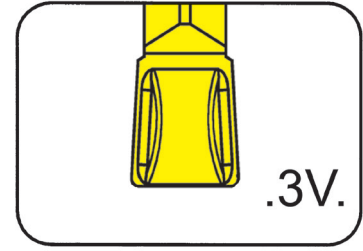

Depth of groove up to	.709"
Width of groove	.079 - .157"

precision sintered

for Toolholder

- Type
- H224
 - HU224
 - B224
 - BU224
 - BK224

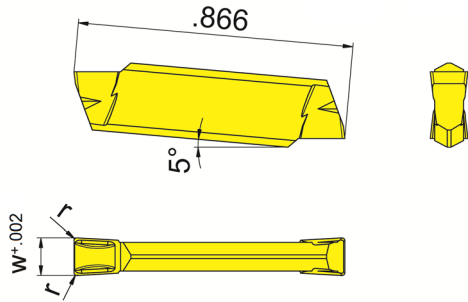

Indexability length $\pm .002''$



Part number	w	r	Size	AS45	HP65	IG35
				▲	▲	▲
S224.0200.3V2	.079	.008	01	▲	▲	▲
S224.0250.3V2	.098	.008	02	▲	▲	▲
S224.0300.3V2	.118	.008	03	▲	▲	x
S224.0400.3V3	.157	.012	04	▲	▲	x
				P	•	•
				M	•	•
				K	•	•
				N	o	o
				S	•	•
				H	-	-

▲ on stock Δ 4 weeks x upon request

- recommended
- o alternative recommendation
- not suitable

- uncoated grades
- coated grades
- brazed/Cermet

Dimensions in inch

Carbide grades

Indexable inserts can be used in right and left hand toolholders.

Indexable insert

S224

with chip former

Depth of groove up to	.709"
Width of groove	.079 - .118"

precision sintered

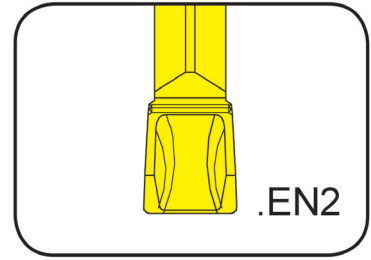

for Toolholder

Type H224
HU224
B224
BU224
BK224

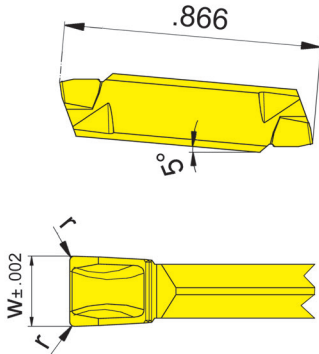

Indexability length ± .002"



Part number	w	r	Size	Carbide grades	
				AS62	AS65
S224.0200.EN2	.079	.008	01	▲	▲
S224.0250.EN2	.098	.008	02	▲	▲
S224.0300.EN2	.118	.008	03	▲	▲
				P	●
				M	○
				K	○
				N	-
				S	-
				H	-

- ▲ on stock Δ 4 weeks x upon request
- recommended
- alternative recommendation
- not suitable
- uncoated grades
- coated grades
- brazed/Cermet

Dimensions in inch

Further sizes upon request

Indexable inserts can be used in right and left hand toolholders.

Indexable insert

S224

with chip breaker

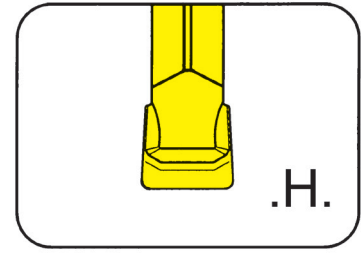

Depth of groove up to
Width of groove

.709"
.118 - .236"

precision sintered

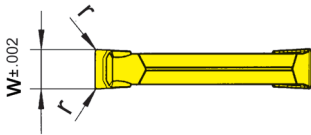
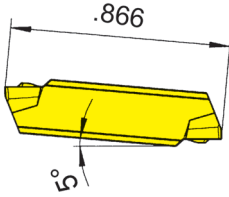

for Toolholder

Type H224
HU224
B224
BU224
BK224

Indexability length $\pm .002''$



Part number	w	r	Size	Carbide grades	
				AL96	TF42
S224.0300.H4	.118	.016	03	▲	▲
S224.0400.H4	.157	.016	04	▲	▲
S224.0500.H6	.197	.024	05	▲	▲
S224.0500.H8	.197	.031	05	▲	x
S224.0600.H6	.236	.024	06	▲	▲
S224.0600.H8	.236	.031	06	x	▲
				P	•
				M	-
				K	•
				N	•
				S	-
				H	-

▲ on stock Δ 4 weeks x upon request

● recommended

o alternative recommendation

- not suitable

□ uncoated grades

■ coated grades

■ brazed/Cermet

Dimensions in inch

Indexable inserts can be used in right and left hand toolholders.

Carbide grades

Indexable insert

S224

with chip forming

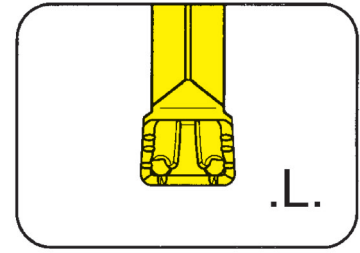

Depth of groove up to	.709"
Width of groove	.118 - .236"

precision sintered

for Toolholder

Type H224
HU224
B224
BU224
BK224

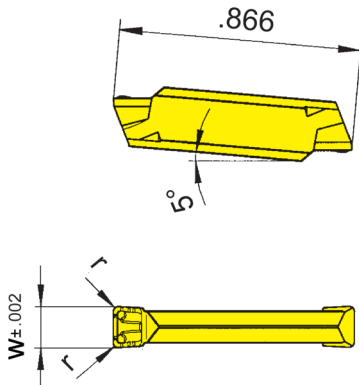

Indexability length ± .002"



Part number	w	r	Size	AL96	AS62	AS65	AS66	ASG6	TF42	T122
				S224.0300.L4	.118	.016	03	▲	▲	▲
S224.0400.L4	.157	.016	04	▲	▲	▲	▲	▲	▲	▲
S224.0500.L4	.197	.016	05	▲	▲	▲	▲	x	▲	▲
S224.0500.L6	.197	.024	05	▲	▲	▲	▲	x	▲	▲
S224.0600.L4	.236	.016	06	▲	▲	▲	▲	▲	▲	▲
S224.0600.L6	.236	.024	06	▲	▲	▲	▲	x	▲	▲
P	●	●	●	●	●	●	●	●	●	●
M	-	-	o	o	o	-	-	-	-	-
K	●	-	o	●	o	-	-	-	-	-
N	●	-	-	●	-	-	-	-	-	-
S	-	-	-	o	-	-	-	-	-	-
H	-	-	-	-	-	-	-	-	-	-

▲ on stock Δ 4 weeks x upon request
● recommended
o alternative recommendation
- not suitable
■ uncoated grades
■ coated grades
■ brazed/Cermet

Carbide grades

Indexable inserts can be used in right and left hand toolholders.

Insert

S124

with chip forming

Depth of groove up to	.709"
Width of groove	.236"

precision sintered

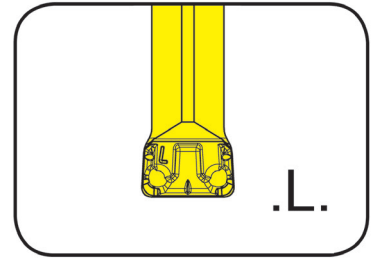

for Toolholder

Type H224
HU224
B224
BU224
BK224

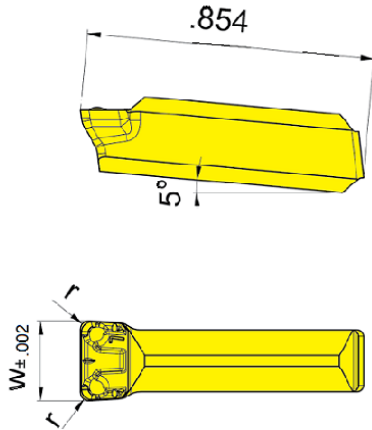

Part number	w	r	Size	Carbide grades	
				AS42	AS46
S124.0600.L6	.236	.024	06	▲	▲
				P ● ○	○
				M ● ○	○
				K ● ●	○
				N ● ○	○
				S ● ○	○
				H - -	-

▲ on stock Δ 4 weeks x upon request
● recommended
○ alternative recommendation
- not suitable

□ uncoated grades
■ coated grades
■ brazed/Cermet

Dimensions in inch

Carbide grades

Indexable inserts can be used in **right and left** hand toolholders.



Indexable insert

S224

with chip forming

Depth of groove up to
Width of groove

.709"
.079 - .118"

precision ground and polished

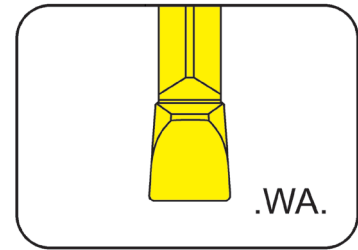

for Toolholder

Type H224
HU224
B224
BU224
BK224

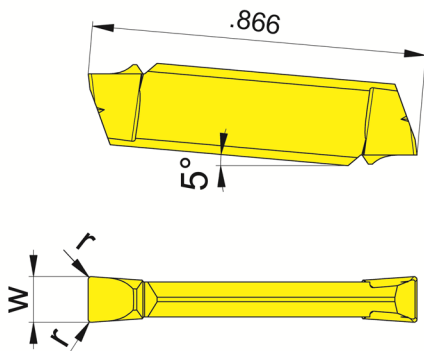

G

Part number	w	r	Size	K10	DD26
S224.0200.WA2	.079	.008	01	▲	▲
S224.0300.WA2	.118	.008	03	▲	▲
				P ●	-
				M ○	-
				K ●	-
				N ●	●
				S ○	○
				H -	-

▲ on stock Δ 4 weeks x upon request

● recommended
○ alternative recommendation
- not suitable

□ uncoated grades
■ coated grades
■ brazed/Cermet

Dimensions in inch

Carbide grades

Indexable inserts can be used in right and left hand toolholders.

Grooving and Side Turning



Indexable insert

S224

with chip forming

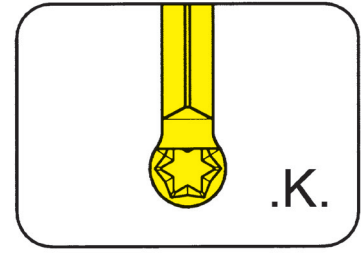

Depth of groove up to	.709"
Width of groove	.079 - .236"
Full radius	.039 - .118"

precision sintered

for Toolholder

- Type
- H224
 - HU224
 - B224
 - BU224
 - BK224

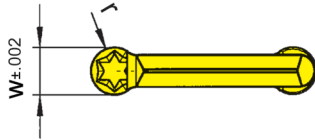
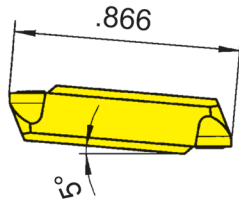

Indexability length ± .002"

Part number	w	r	Size	Carbide grades								
				P20	AL96	AS62	AS66	TC92	TF42	TN32	TN35	
S224.0010.K2	.079	.039	01			▲	▲		▲			
S224.0015.K3	.118	.059	03	x	▲	▲	▲		▲	▲	▲	
S224.0020.K4	.157	.079	04	x	▲	▲	▲		▲	▲	▲	
S224.0025.K5	.197	.098	05	x	▲	▲	▲		▲	▲	▲	x
S224.0030.K6	.236	.118	06	x			▲	▲				
P	●	●	●	●	●	●	●	●	●	●	●	●
M	-	-	-	○	-	-	-	-	-	-	-	●
K	-	●	-	●	-	-	-	-	-	-	-	●
N	-	●	-	●	-	-	-	-	-	-	-	●
S	-	-	-	○	-	-	-	-	-	-	-	●
H	-	-	-	-	-	-	-	-	-	-	-	-

- ▲ on stock Δ 4 weeks x upon request
- recommended
- alternative recommendation
- not suitable
- uncoated grades
- coated grades
- brazed/Cermet

Dimensions in inch

Carbide grades

Indexable inserts can be used in right and left hand toolholders.

Dmin for corner reliefs with 45° toolholder

t _{max}	S224.0010.K2	S224.0015.K3	S224.0020.K4	S224.0025.K5	S224.0030.K6
.02	Ø 1.339	Ø 1.024	Ø .866	Ø .827	Ø .551
.039	Ø 2.126	Ø 1.417	Ø 1.024	Ø .866	Ø .709
.059	Ø 2.126	Ø 1.417	Ø 1.024	Ø .866	Ø .709
.079	Ø 2.165	Ø 1.417	Ø 1.024	Ø .866	Ø .709
.098	Ø 2.205	Ø 1.417	Ø 1.024	Ø .866	Ø .709
.118	-	-	-	Ø .866	Ø .709



Indexable insert

S224

with chip forming

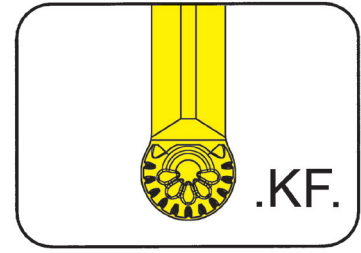

Depth of groove up to .709"
 Width of groove .118 - .236"
 Full radius .059 - .118"

precision sintered

for Toolholder

Type H224
 HU224
 B224
 BU224
 BK224

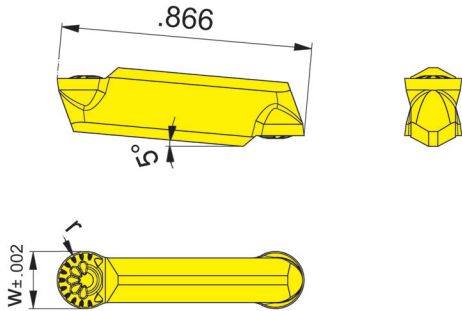

Indexability length ± .002"

G

Part number	w	r	Size	Carbide grades		
				AS62	AS66	TA42
S224.0010.KF2	.079	.039	01		▲	
S224.0015.KF3	.118	.059	03		▲	x
S224.0020.KF4	.157	.079	04		▲	Δ
S224.0025.KF5	.197	.098	05	Δ	▲	x
S224.0030.KF6	.236	.118	06	x	▲	
				P	●	●
				M	-	○
				K	-	●
				N	-	●
				S	-	○
				H	-	-

- ▲ on stock Δ 4 weeks x upon request
- recommended
- alternative recommendation
- not suitable
- uncoated grades
- coated grades
- brazed/Cermet

Dimensions in inch

Carbide grades

Indexable inserts can be used in right and left hand toolholders.

Dmin for corner reliefs with 45° toolholder

t _{max}	S224.0010.KF2	S224.0015.KF3	S224.0020.KF4	S224.0025.KF5	S224.0030.KF6
.02	Ø 1.024	Ø .866	Ø .827	Ø .551	Ø .551
.039	Ø 1.417	Ø 1.024	Ø .866	Ø .709	Ø .709
.059	Ø 1.417	Ø 1.024	Ø .866	Ø .709	Ø .709
.079	Ø 1.417	Ø 1.024	Ø .866	Ø .709	Ø .709
.098	Ø 1.417	Ø 1.024	Ø .866	Ø .709	Ø .709
.118	-	-	Ø .866	Ø .709	Ø .709

Indexable insert

S224

with chip forming

Depth of groove up to
Width of groove

.709"
.098 - .118"

precision ground

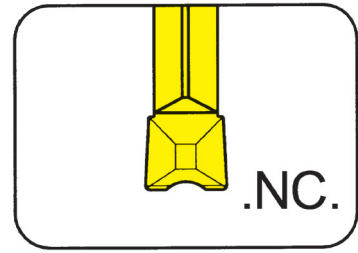

for Toolholder

Type H224
HU224
B224
BU224
BK224

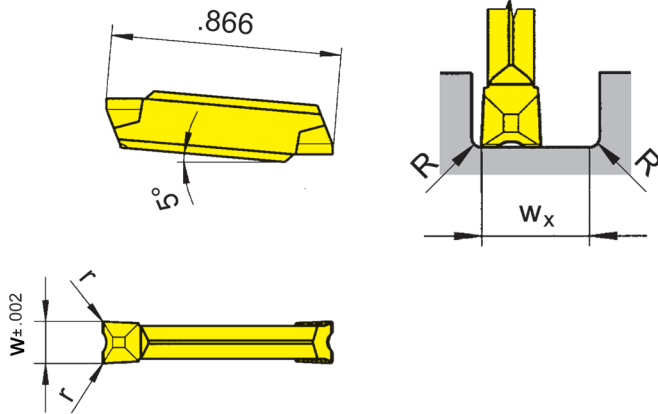

Indexability length $\pm .001''$



Part number	w	r	w _x	Size	TF46	Tl22	Tl25	Tl26
S224.NC25.D2	.098	.008	.142	02	x	Δ	▲	▲
S224.NC30.D2	.118	.008	.177	03	x	▲	▲	▲
					P	•	•	•
					M	o	-	o
					K	•	-	•
					N	•	-	•
					S	o	-	o
					H	-	-	-

Carbide grades

▲ on stock Δ 4 weeks x upon request

- recommended
- o alternative recommendation
- not suitable

- uncoated grades
- coated grades
- brazed/Cermet

Dimensions in inch

$$w_x = \text{width of groove} - R_{(\text{right})} - R_{(\text{left})}$$

Indexable inserts can be used in right and left hand toolholders.

Indexable insert

S224

with chip former

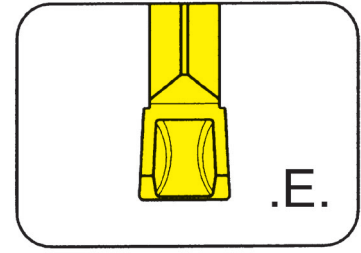

Depth of groove up to
Width of groove

.709"
.079 - .157"

precision sintered

for Toolholder

Type H224
HU224
B224
BU224
BK224

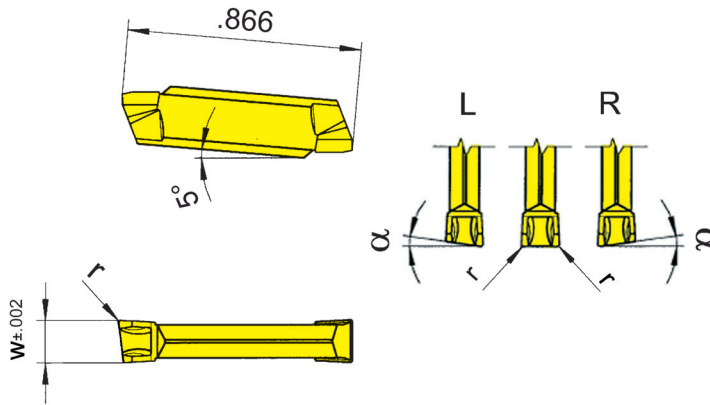

Indexability length ± .002"

R = right hand version shown

L = left hand version

Part number	w	r	α	Size	AL96	AS62	TA43	TC92	TC93	TF43	TF45	TI22	TI25	TN32	TN35
S224.0200.E2	.079	.008	0°	01		▲		▲	▲	▲	▲				
R/LS224.0520.E2	.079	.008	5°	01		▲/▲		x/x	x/x	x/x	x/x				
S224.0250.E2	.098	.008	0°	02		▲		▲	x	▲	▲				
R/LS224.0525.E2	.098	.008	5°	02		▲/▲		x/x	x/x	x/x	Δ/x				
S224.0300.E2	.118	.008	0°	03	x	▲	x	▲	▲	▲	▲	▲	▲	x	x
S224.0300.E4	.118	.016	-	03	x	▲		x	x	▲	▲		x	x	x
R/LS224.0530.E2	.118	.008	5°	03		▲/▲		▲/x	x/x	▲/x	▲/▲				
S224.0400.E2	.157	.008	0°	04	x	▲		x	x	x	▲		x	x	x
S224.0400.E4	.157	.016	-	04	x	▲		x	x	x	▲		x	x	x
					P	•	•	•	•	•	•	•	•	•	•
					M	-	-	-	-	-	•	-	•	-	•
					K	•	-	-	-	-	•	-	•	-	•
					N	•	-	-	-	-	•	-	•	-	•
					S	-	-	-	-	-	•	-	•	-	•
					H	-	-	-	-	-	-	-	-	-	-

▲ on stock Δ 4 weeks x upon request

• recommended
o alternative recommendation
- not suitable

uncoated grades
coated grades
brazed/Cermet

Dimensions in inch

Carbide grades

State R or L version

Further sizes upon request

Indexable inserts can be used in right and left hand toolholders.

Indexable insert

S224

with chip forming

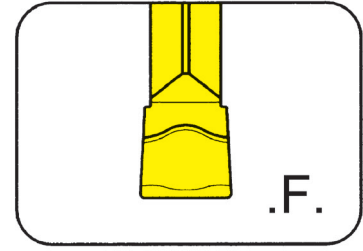

Depth of groove up to
Width of groove

.709"
.079 - .157"

precision sintered

for Toolholder

Type H224
HU224
B224
BU224
BK224

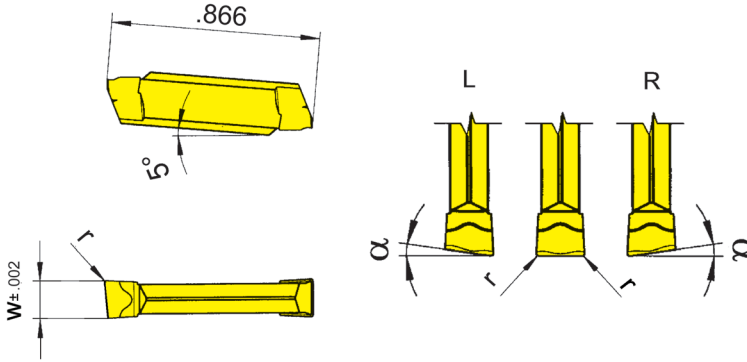

Indexability length ± .002"



Part number	w	r	α	Size	Carbide grades									
					AL96	TA43	TF42	TF43	TF45	TF46	TI22	TI25	TN32	
S224.0200.F2	.079	.008	0°	01	x		x	▲	▲	▲	▲	▲	▲	x
R/LS224.0520.F2	.079	.008	5°	01					▲/▲	▲/Δ				
S224.0250.F2	.098	.008	0°	02	x		x	▲	▲	▲	▲	x	▲	x
R/LS224.0525.F2	.098	.008	5°	02				▲/Δ	▲/Δ					
S224.0300.F2	.118	.008	0°	03	x	x		▲	▲	▲	x	▲	▲	x
R/LS224.0530.F2	.118	.008	5°	03				▲/Δ	▲/▲		▲/x			
S224.0400.F2	.157	.008	0°	04	x		x		▲		▲	x	▲	x
▲ on stock Δ 4 weeks x upon request					P	•	•	•	•	•	•	•	•	•
• recommended					M	-	-	-	-	o	-	•	-	-
o alternative recommendation					K	•	-	-	-	•	-	•	-	-
- not suitable					N	•	-	-	-	•	-	•	-	-
uncoated grades					S	-	-	-	-	o	-	•	-	-
coated grades					H	-	-	-	-	-	-	-	-	-
brazed/Cermet														

Dimensions in inch

Carbide grades

State R or L version

Indexable inserts can be used in right and left hand toolholders.

Indexable insert

S224

with chip forming

Depth of groove up to
Width of groove

.709"
.079 - .118"

precision sintered

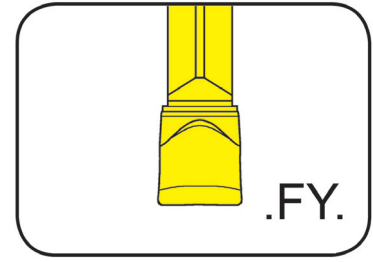

for Toolholder

Type H224
HU224
B224
BU224
BK224

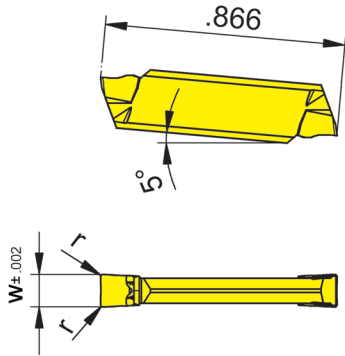

Indexability length $\pm .002''$

G

Part number	w	r	Size	Carbide grades				
				HP65	IG35	PH35	TI25	
S224.0200.FY2	.079	.008	01	▲	▲	▲	▲	
S224.0250.FY2	.098	.008	02	▲	▲	▲	▲	
S224.0300.FY2	.118	.008	03	▲	▲	▲	▲	
				P	•	-	o	•
				M	•	•	o	•
				K	•	-	•	•
				N	o	-	-	•
				S	•	•	-	•
				H	-	-	-	-

- ▲ on stock Δ 4 weeks x upon request
- recommended
- o alternative recommendation
- not suitable
- uncoated grades
- coated grades
- brazed/Cermet

Dimensions in inch

Carbide grades

Indexable inserts can be used in right and left hand toolholders.

Indexable insert

S224

with chip forming

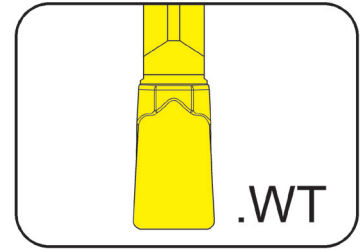

Width of groove	.079 - .118"
Depth of groove up to	.709"

precision sintered

for Toolholder / Cassette

- Type
- H224
 - HU224
 - B224
 - BU224
 - BK224

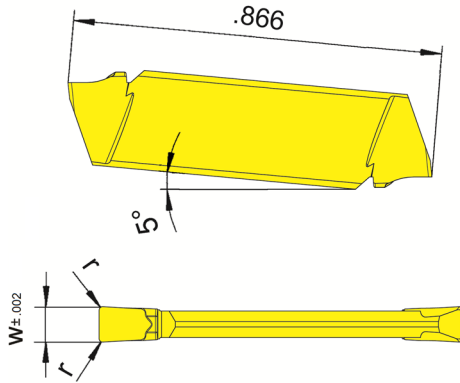

Part number	w	r	Size	IG35
S224.0200.WT2	.079	.008	01	▲
S224.0250.WT2	.098	.008	02	▲
S224.0300.WT2	.118	.008	03	▲

▲ on stock Δ 4 weeks x upon request

- recommended
- alternative recommendation
- not suitable

- uncoated grades
- coated grades
- brazed/Cermet

Dimensions in inch

P	-
M	•
K	-
N	-
S	•
H	-

Carbide grades

Indexable inserts can be used in right and left hand toolholders.



Indexable insert

S224

with chip forming

Width of groove	.118"
-----------------	-------

precision sintered

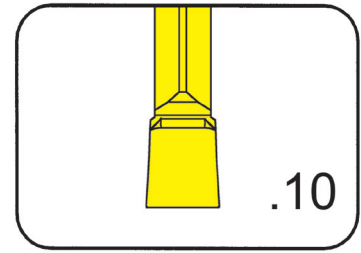

for Toolholder

Type H224
HU224
B224
BU224
BK224

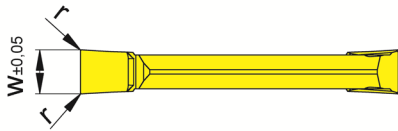
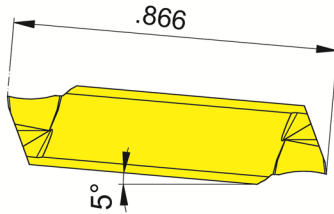

G

Part number	w	r	Size	EG35	Carbide grades
S224.0200.10	.079	.002	02	▲	P ●
S224.0250.10	.098	.004	02	▲	M ●
S224.0300.10	.118	.004	03	▲	K ○
					N -
					S -
					H -

▲ on stock Δ 4 weeks x upon request

- recommended
- alternative recommendation
- not suitable

- uncoated grades
- coated grades
- brazed/Cermet

Dimensions in inch

Carbide grades

Indexable inserts can be used in right and left hand toolholders.

Indexable insert

S224

with chip former

Width of groove	.118"
-----------------	-------

precision sintered

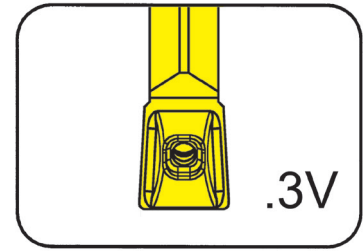

for Toolholder

Type H224
HU224
B224
BU224
BK224

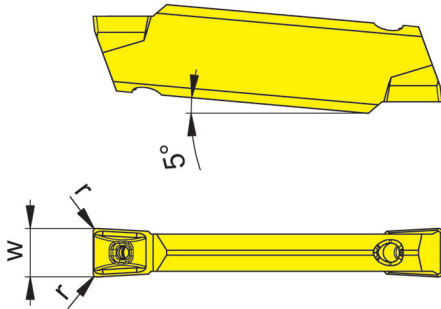

Coolant supply through insert



Part number	w	r	Size	Carbide grades	
				HP65	IG35
S224.0300.3V2.IK	.118	.008	03	▲	x
▲ on stock Δ 4 weeks x upon request ● recommended ○ alternative recommendation - not suitable □ uncoated grades ■ coated grades ■ brazed/Cermet Dimensions in inch				P	•
				M	•
				K	•
				N	○
				S	•
				H	-

Indexable inserts can be used in right and left hand toolholders.

Threading (external) Full profile



Indexable insert

S224

Metric ISO-thread

Pitch, mm	0.5 - 2.0 mm
-----------	--------------

precision ground

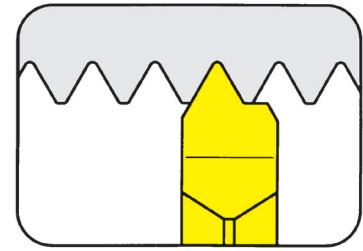

for Toolholder

- Type
- H224
 - HU224
 - B224
 - BU224
 - BK224

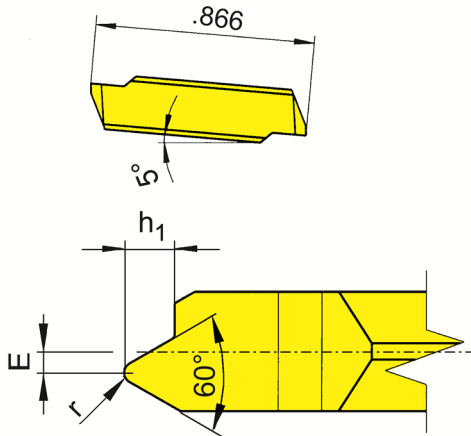

R = right hand version shown

L = left hand version

Indexability length $\pm .001''$

Part number	Pitch mm	E	h ₁	Size	Carbide grades	
					EG55	TF45
R/LS224.0305.02	0.50	.039	.012	03	▲/▲	▲/▲
R/LS224.0407.02	0.75	.035	.018	03	▲/▲	▲/▲
R/LS224.0610.02	1.00	.031	.024	03	▲/▲	▲/▲
R/LS224.0712.02	1.25	.028	.030	03	▲/▲	▲/▲
R/LS224.0915.02	1.50	.020	.036	03	▲/▲	▲/▲
R/LS224.1017.02	1.75	.016	.042	03	▲/▲	▲/▲
R/LS224.1220.02	2.00	.012	.048	03	▲/▲	▲/▲

- ▲ on stock Δ 4 weeks x upon request
- recommended
- alternative recommendation
- not suitable
- uncoated grades
- coated grades precision sintered
- brazed/Cermet

P	●	●
M	○	●
K	○	●
N	-	●
S	-	●
H	-	-

Dimensions in inch

State R or L version

Carbide grades

No shims necessary. All HORN thread profiles are manufactured with **fully ground radial clearance**.

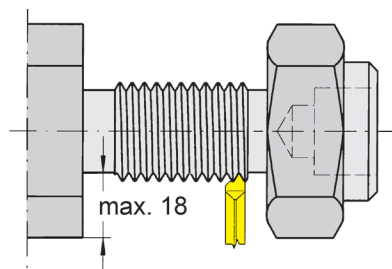

Suitable for threading behind a shoulder

Threading (external) Full profile



Indexable insert

NS224

Whitworth pipe thread

Threads per inch	11 - 28
------------------	---------

precision ground

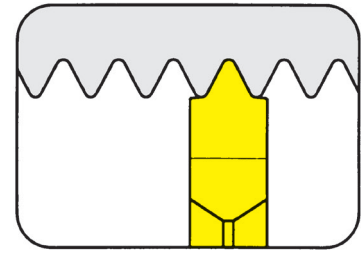

for Toolholder

Type H224
HU224
B224
BU224
BK224

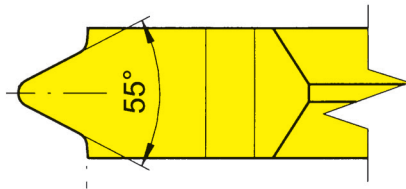
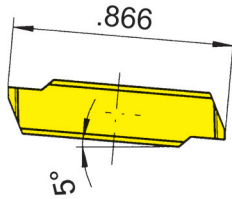

Indexability length $\pm .001''$

Part number	TPI	Size	Carbide grades	
			EG55	TA45
NS224.5511.02	11	03	▲	▲
NS224.5514.02	14	03	▲	▲
NS224.5519.02	19	03	▲	▲
NS224.5528.02	28	03	▲	▲
			P ●	●
			M ○	●
			K ○	●
			N -	●
			S -	●
			H -	-

▲ on stock Δ 4 weeks x upon request

● recommended
○ alternative recommendation
- not suitable

■ uncoated grades
■ coated grades
■ brazed/Cermet

Dimensions in inch

Carbide grades

No shims necessary. All HORN thread profiles are manufactured with **fully ground radial clearance**.

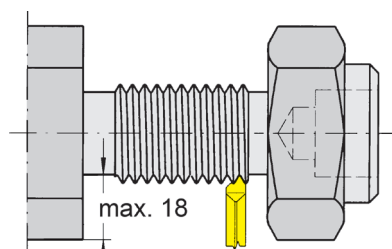

Suitable for threading behind a shoulder





229/259



H

Toolholder with Inserts

Width of groove .098 - .394"

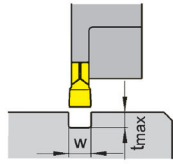

$w = .098 - .394"$
(2.5 - 10 mm)
 $t_{max} = .984"$ (25 mm)

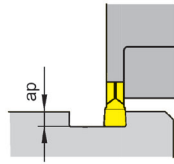

$w = .118 - .236"$
(3 - 6 mm)
 $a_p \leq .157"$ (4 mm)

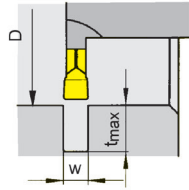

$w = .118 - .394"$
(3 - 10 mm)
 $t_{max} = 0.591"$ (15 mm)
 $D \geq 1.496"$ (38 mm)

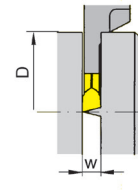

$w = .118 - .157"$
(3 - 4 mm)
 $t_{max} = .984"$ (25 mm)

Grooving External

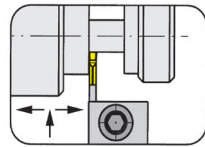

Page H4-H13

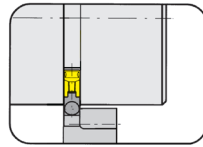

Page H14-H25

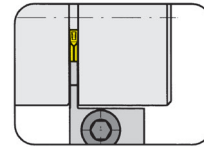

Page H26-H32

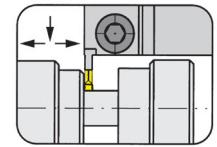

Page H33-H36

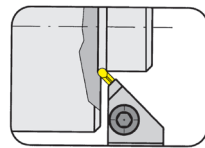

Page H37-H38

Grooving Internal

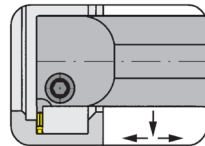

Page H39-H50

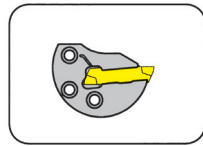

Page H51-H55

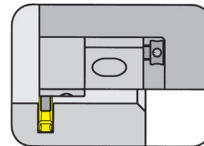

Page H56

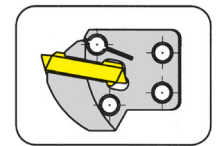

Page H57

Indexable Insert S229

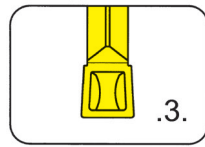

Page H59

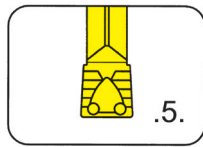

Page H61

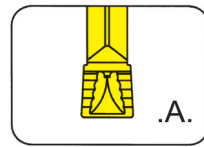

Page H63

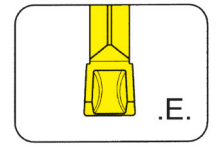

Page H64

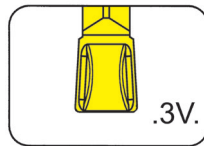

Page H67

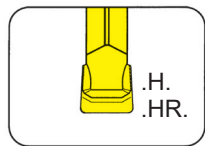

Page H68-H69

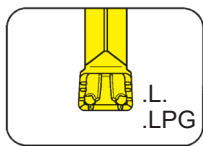

Page H70-H71

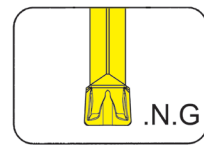

Page H72

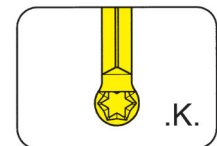

Page H74-H75

Indexable Insert 229

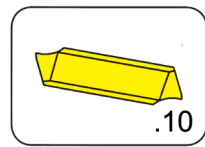

Page H77

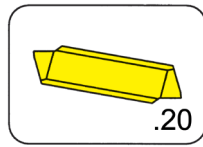

Page H79

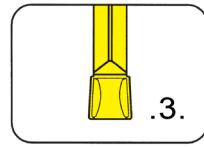

Page H81

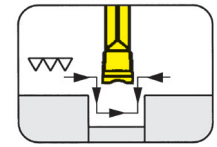

Page H82

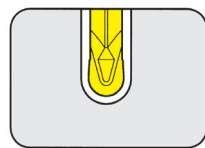

Page H84

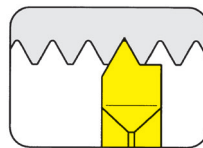

Page H85-H87

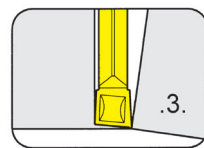

Page H88

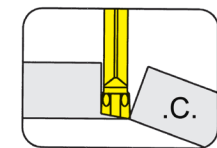

Page H89-H90

Toolholder H259

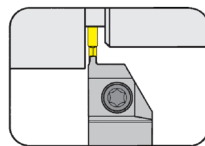

Page H91

Indexable Insert 259

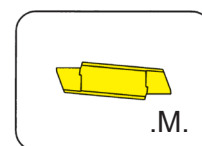

Page H92

H



H

Basic toolholder

U210

with changeable cassette

Depth of groove up to
Clamping range

.433"
.118 - .315"

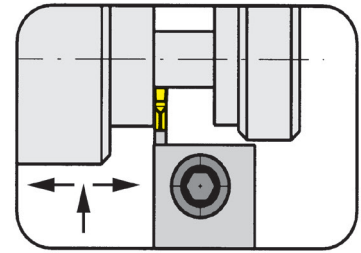

for Indexable insert

Type 229
S229
N229

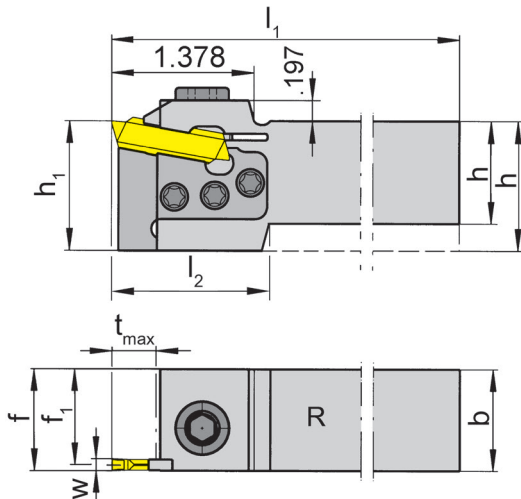

R = right hand version shown

L = left hand version

Part number	h	b	l ₁	l ₂	h ₁	f ₁	f	t _{max}	Size	Clamping range
R/LU210.1000.K3	1.000	1	6.004	1.378	1.250	.943	f ₁ +w/2	.433	03	.118 - .157
R/LU210.1250.K3	1.250	1	6.693	1.378	1.260	.943	f ₁ +w/2	.433	03	.118 - .157
R/LU210.1000.K4	1.000	1	6.004	1.378	1.260	.909	f ₁ +w/2	.433	04	.157 - .200
R/LU210.1250.K4	1.250	1	6.693	1.378	1.250	.909	f ₁ +w/2	.433	04	.157 - .200
R/LU210.1000.K5	1.000	1	6.004	1.378	1.260	.890	f ₁ +w/2	.433	05	.201 - .236
RU210.1250.K5	1.250	1	6.693	-	1.250	.890	f ₁ +w/2	.433	05	.201 - .236
R/LU210.1000.K7	1.000	1	6.004	1.378	1.260	.850	f ₁ +w/2	.433	07	.240 - .319
R/LU210.1250.K7	1.250	1	6.693	1.378	1.250	.850	f ₁ +w/2	.433	07	.240 - .319

State R or L version

w see indexable inserts

Dimensions in inch

Further sizes upon request

For torque specification of the screw, please see Technical Instructions.

Spare Parts

Basic toolholder	Clamping Screw	Allen wrench	Cassette	TORX PLUS® Wrench
R/LU210...K3	030.0518.T20P	SW6,0 DIN911	NK210.32.03	T20PQ
R/LU210...K4	030.0518.T20P	SW6,0 DIN911	NK210.32.04	T20PQ
R/LU210...K5	030.0518.T20P	SW6,0 DIN911	NK210.32.05	T20PQ
R/LU210...K7	030.0518.T20P	SW6,0 DIN911	NK218.32.07	T20PQ

Basic toolholder

210

with changeable cassette

Depth of groove up to
Clamping range

11 mm
3 - 8 mm

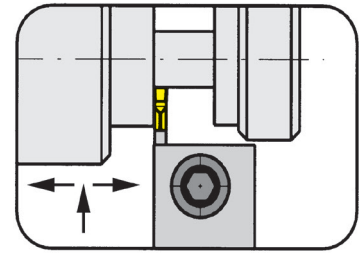

for Indexable insert

Type 229
S229
N229

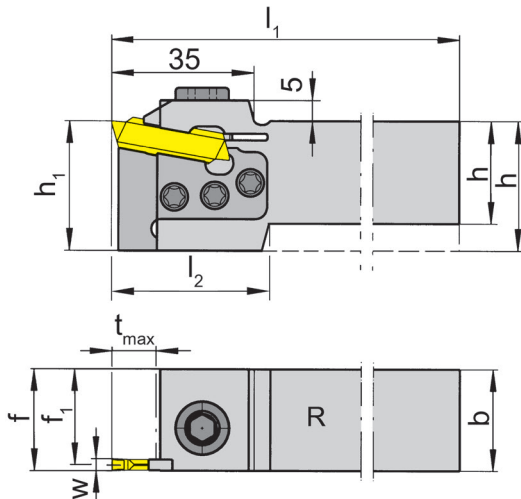

R = right hand version shown

L = left hand version

Part number	h	b	l ₁	l ₂	h ₁	f ₁	f	t _{max}	Size	Clamping range
R/L210.2525.K3	25	25	150	35	32	23.55	f ₁ +w/2	11	03	3.0 - 4.0
R/L210.3225.K3	32	25	170	-	32	23.55	f ₁ +w/2	11	03	3.0 - 4.0
R/L210.2525.K4	25	25	150	35	32	22.70	f ₁ +w/2	11	04	4.0 - 5.0
R/L210.3225.K4	32	25	150	-	32	22.70	f ₁ +w/2	11	04	4.0 - 5.0
R/L210.2525.K5	25	25	150	35	32	22.20	f ₁ +w/2	11	05	5.1 - 6.0
R/L210.3225.K5	32	25	170	-	32	22.20	f ₁ +w/2	11	05	5.1 - 6.0
R/L210.2525.K7	25	25	150	35	32	21.20	f ₁ +w/2	11	07	6.1 - 8.0
R/L210.3225.K7	32	25	170	-	32	21.20	f ₁ +w/2	11	07	6.1 - 8.0

State R or L version

w see indexable inserts

Dimensions in mm

Further sizes upon request

For torque specification of the screw, please see Technical Instructions.

Spare Parts

Basic toolholder	Clamping Screw	Allen wrench	Cassette	TORX PLUS® Wrench
R/L210...K3	030.0518.T20P	SW6,0 DIN911	NK210.32.03	T20PQ
R/L210...K4	030.0518.T20P	SW6,0 DIN911	NK210.32.04	T20PQ
R/L210...K5	030.0518.T20P	SW6,0 DIN911	NK210.32.05	T20PQ
R/L210...K7	030.0518.T20P	SW6,0 DIN911	NK210.32.07	T20PQ



Grooving and Side Turning (external)



Basic toolholder

U210

with changeable cassette

Depth of groove up to
Clamping range

.433"
.319 - .409"

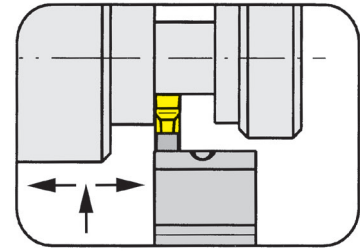

Indexable insert

Type 229
S229
N229

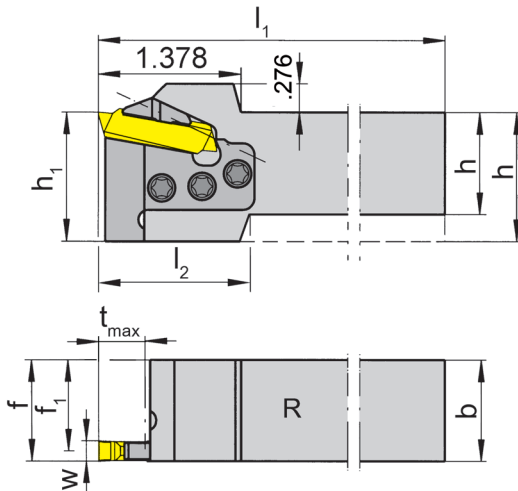

R = right hand version shown

L = left hand version

Part number	h	b	l_1	l_2	h_1	f_1	f	t_{max}	Size	Clamping range
R/LU210.1000.K9	1.000	1	6.004	1.378	1.260	.811	$f_1+w/2$.433	09	.319 - .413
R/LU210.1250.K9	1.250	1	6.693	1.378	1.260	.811	$f_1+w/2$.433	09	.319 - .413

State R or L version

w see indexable inserts

Dimensions in inch

Further sizes upon request

Note:

Please note type of clamp.

For torque specification of the screw, please see Technical Instructions.

Spare Parts

Basic toolholder	Clamping Screw	Cassette	Clamping element	TORX PLUS® Wrench
LU210....	030.0518.T20P	NK210.32.09	L218.9	T20PQ
RU210....	030.0518.T20P	NK210.32.09	R218.9	T20PQ

H6

Call Us Toll Free (888) 818-4676

H

Basic toolholder

210

with changeable cassette

Depth of groove up to
Clamping range

11 mm
8.1 - 10.4 mm

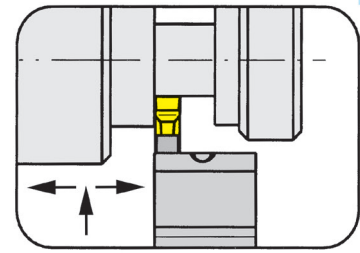

for Indexable insert

Type 229
S229
N229

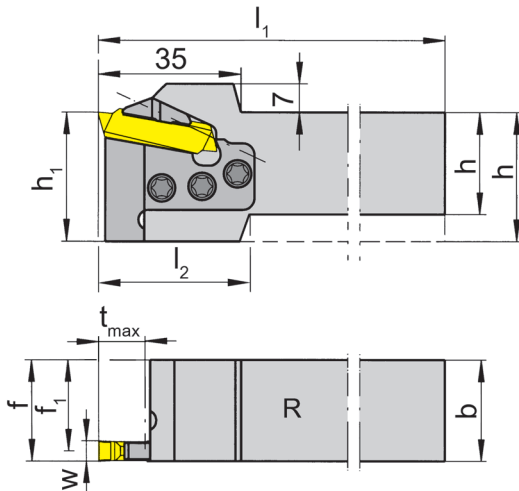

R = right hand version shown

L = left hand version

Part number	h	b	l_1	l_2	h_1	f_1	f	t_{max}	Size	Clamping range
R/L210.2525.K9	25	25	150	35	32	20.2	$f_1+w/2$	11	09	8.1 - 10.4
R/L210.3225.K9	32	25	170	-	32	20.2	$f_1+w/2$	11	09	8.1 - 10.4

State R or L version

w see indexable inserts

Dimensions in mm

Further sizes upon request

Note:

Please note type of clamp.

For torque specification of the screw, please see Technical Instructions.

Spare Parts

Basic toolholder	Clamping Screw	Cassette	Clamping element	TORX PLUS® Wrench
L210...	030.0518.T20P	NK210.32.09	L218.9	T20PQ
R210...	030.0518.T20P	NK210.32.09	R218.9	T20PQ



Grooving and Side Turning (external)



Toolholder

U210

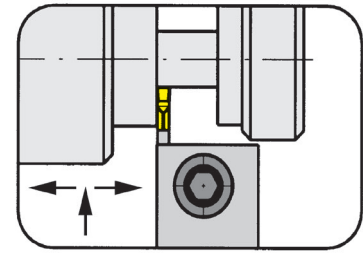

Depth of groove up to .433"
Clamping range .098 - .236"

for Indexable insert

Type 229
S229
N229

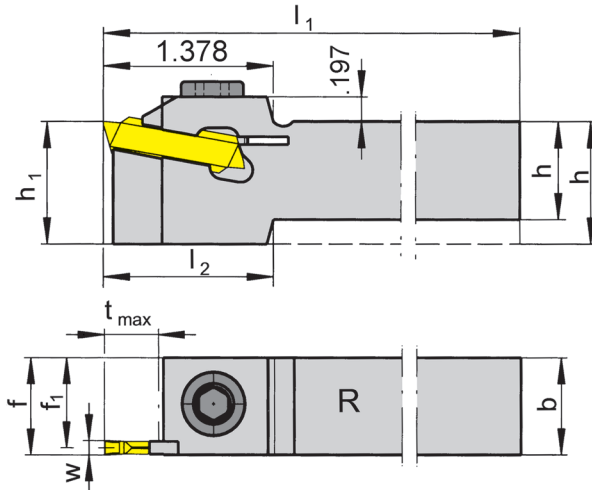

R = right hand version shown

L = left hand version

Part number	h	b	l ₁	l ₂	h ₁	f ₁	f	t _{max}	Size	Clamping range
R/LU210.0750.02	.750	.750	6.004	1.378	1.000	.693	f ₁ +w/2	.433	02	.098 - .118
RU210.1000.02	1.000	1.000	6.004	-	1.000	.943	f ₁ +w/2	.433	02	.098 - .118
R/LU210.0625.03	.625	.625	6.004	1.772	1.000	.567	f ₁ +w/2	.433	03	.118 - .157
R/LU210.0750.03	.750	.750	6.004	1.378	.984	.693	f ₁ +w/2	.433	03	.118 - .157
R/LU210.1000.03	1.000	1.000	6.004	-	1.000	.943	f ₁ +w/2	.433	03	.118 - .157
R/LU210.1250.03	1.250	1.000	6.693	-	1.250	.943	f ₁ +w/2	.433	03	.118 - .157
R/LU210.0750.04	.750	.750	6.004	1.378	1.000	.659	f ₁ +w/2	.433	04	.157 - .200
R/LU210.1000.04	1.000	1.000	6.004	-	1.000	.909	f ₁ +w/2	.433	04	.157 - .200
R/LU210.1250.04	1.250	1.000	6.693	-	1.250	.909	f ₁ +w/2	.433	04	.157 - .200
R/LU210.0750.05	.750	.750	6.004	1.378	1.000	.640	f ₁ +w/2	.433	05	.201 - .236
R/LU210.1000.05	1.000	1.000	6.004	-	1.000	.890	f ₁ +w/2	.433	05	.201 - .240
R/LU210.1250.05	1.250	1.000	6.693	-	1.250	.890	f ₁ +w/2	.433	05	.201 - .240

State R or L version

w see indexable inserts

Dimensions in inch

R/L 210...02 max. depth of groove up to Ø 5.906"

Further sizes upon request

For torque specification of the screw, please see Technical Instructions.

Spare Parts

Toolholder	Clamping Screw	Allen wrench
R/LU210...	218.3	SW6,0 DIN911

H8

Call Us Toll Free (888) 818-4676

Grooving and Side Turning (external)



Toolholder

210

Depth of groove up to
Clamping range

11 mm
2.5 - 6 mm

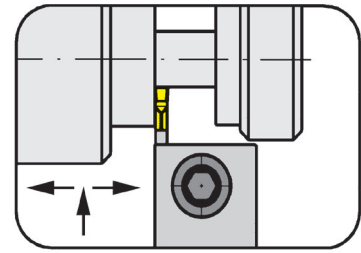

for Indexable insert

Type 229
S229
N229

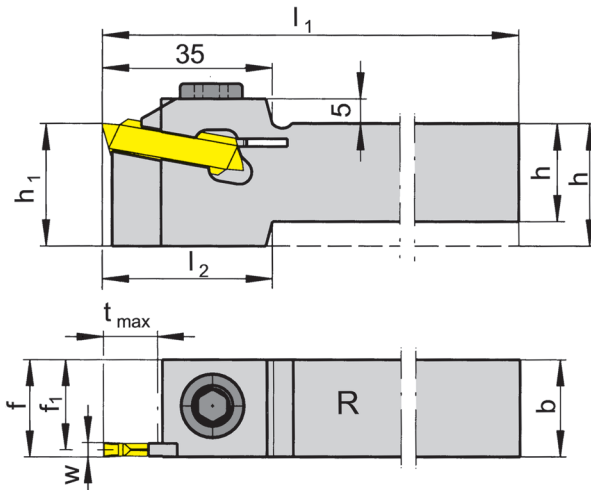

R = right hand version shown

L = left hand version

Part number	h	b	l ₁	l ₂	h ₁	f ₁	f	t _{max}	Size	Clamping range
R/L210.2020.02	20	20	150	35	25	18.55	f ₁ +w/2	11	02	2.5 - 3.0
R/L210.2525.02	25	25	150	-	25	23.55	f ₁ +w/2	11	02	2.5 - 3.0
R/L210.1616.03	16	16	150	45	25	14.55	f ₁ +w/2	11	03	3.0 - 4.0
R/L210.2020.03	20	20	150	35	25	18.55	f ₁ +w/2	11	03	3.0 - 4.0
R/L210.2525.03	25	25	150	-	25	23.55	f ₁ +w/2	11	03	3.0 - 4.0
R/L210.3225.03	32	25	170	-	32	23.55	f ₁ +w/2	11	03	3.0 - 4.0
R/L210.2020.04	20	20	150	35	25	17.70	f ₁ +w/2	11	04	4.0 - 5.0
R/L210.2525.04	25	25	150	-	25	22.70	f ₁ +w/2	11	04	4.0 - 5.0
R/L210.3225.04	32	25	170	-	32	22.70	f ₁ +w/2	11	04	4.0 - 5.0
R/L210.2020.05	20	20	150	35	25	17.20	f ₁ +w/2	11	05	5.1 - 6.0
R/L210.2525.05	25	25	150	-	25	22.20	f ₁ +w/2	11	05	5.1 - 6.0
R/L210.3225.05	32	25	170	-	32	22.20	f ₁ +w/2	11	05	5.1 - 6.0

State R or L version

w see indexable inserts

Dimensions in mm

R/L 210...02 max. depth of groove up to Ø 150 mm

Further sizes upon request

For torque specification of the screw, please see Technical Instructions.

Spare Parts

Toolholder	Clamping Screw	Allen wrench
R/L210...	218.3	SW6,0 DIN911



Toolholder

U210

Depth of groove up to
Clamping range

.433"
.240 - .315"

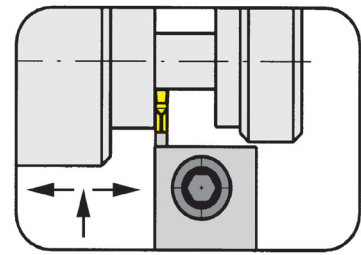

for Indexable insert

Type 229
S229
N229

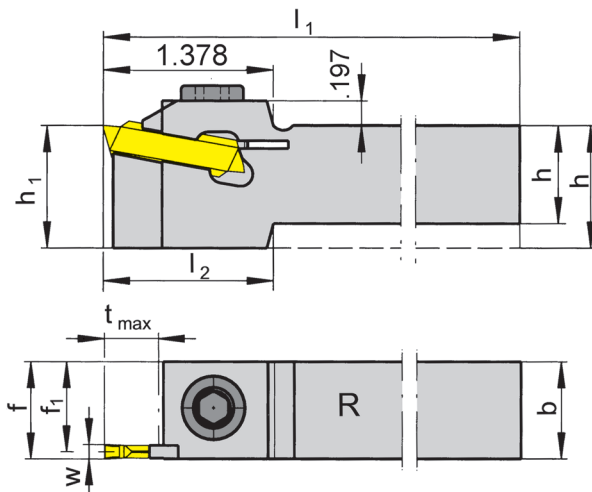

R = right hand version shown

L = left hand version

Part number	h	b	l_1	h_1	f_1	f	t_{max}	l_2	Size	Clamping range
R/LU210.0750.07	.750	.750	6.004	.984	.600	$f_1+w/2$.433	1.378	07	.240 - .319
R/LU210.1000.07	1.000	1.000	6.004	1.000	.848	$f_1+w/2$.433	-	07	.240 - .319
R/LU210.1250.07	1.250	1.000	6.693	1.250	.848	$f_1+w/2$.433	-	07	.240 - .319

State R or L version

w see indexable inserts

Dimensions in inch

Further sizes upon request

For torque specification of the screw, please see Technical Instructions.

Spare Parts

Toolholder	Clamping Screw	Allen wrench
R/LU210...	218.3	SW6,0 DIN911

Grooving and Side Turning (external)



Toolholder

210

Depth of groove up to
Clamping range

11 mm
6.1 - 8 mm

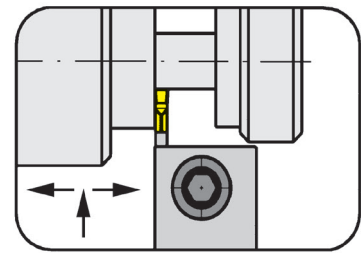

for Indexable insert

Type 229
S229
N229

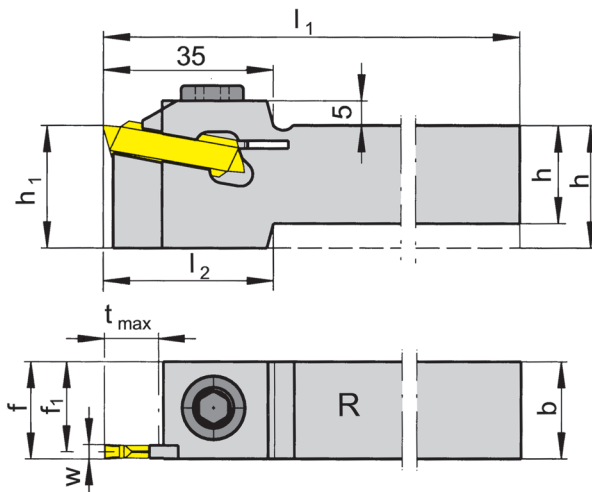

R = right hand version shown

L = left hand version

Part number	h	b	l ₁	l ₂	h ₁	f ₁	f	t _{max}	Size	Clamping range
R/L210.2020.07	20	20	150	35	25	16.2	f ₁ +w/2	11	07	6.1 - 8.0
R/L210.2525.07	25	25	150	-	25	21.2	f ₁ +w/2	11	07	6.1 - 8.0
R/L210.3225.07	32	25	170	-	32	21.2	f ₁ +w/2	11	07	6.1 - 8.0
R/L210.2020.08	20	20	150	35	25	16.2	f ₁ +w/2	11	08	7.6 - 8.0
R/L210.2525.08	25	25	150	-	25	21.2	f ₁ +w/2	11	08	7.6 - 8.0

State R or L version

w see indexable inserts

Dimensions in mm

Further sizes upon request

For torque specification of the screw, please see Technical Instructions.

Spare Parts

Toolholder	Clamping Screw	Allen wrench
R/L210...	218.3	SW6,0 DIN911



Toolholder

U210

Depth of groove up to
Clamping range

.433"
.319 - .409"

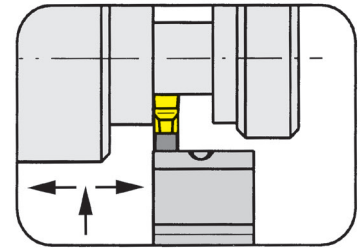

for Indexable insert

Type 229
S229

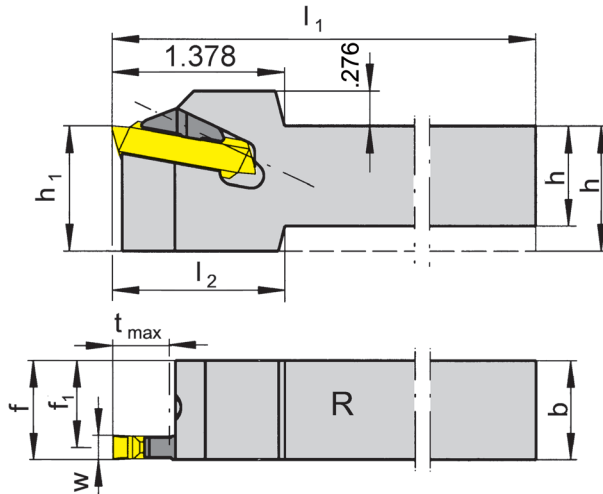

R = right hand version shown

L = left hand version

Part number	h	b	l ₁	l ₂	h ₁	f ₁	f	t _{max}	Size	Clamping range
R/LU210.0750.09	.750	.750	6.004	1.378	1.000	.561	f ₁ +w/2	.433	09	.319 - .413
R/LU210.1000.09	1.000	1.000	6.004	1.378	1.000	.811	f ₁ +w/2	.433	09	.319 - .409
R/LU210.1250.09	1.250	1.000	6.693	-	1.250	.811	f ₁ +w/2	.433	09	.319 - .409

State R or L version

w see indexable inserts

Dimensions in inch

Further sizes upon request

Note:

Please note type of clamp.

For torque specification of the screw, please see Technical Instructions.

Spare Parts

Toolholder	Clamping element	TORX PLUS® Wrench
LU210...	L218.9	T15PQ
RU210...	R218.9	T15PQ



Grooving and Side Turning (external)



Toolholder

210

Depth of groove up to
Clamping range

11 mm
8.1 - 10.4 mm

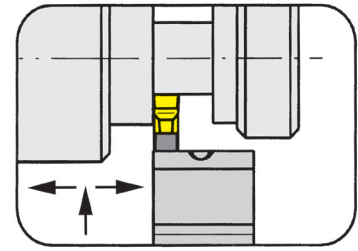

for Indexable insert

Type 229
S229

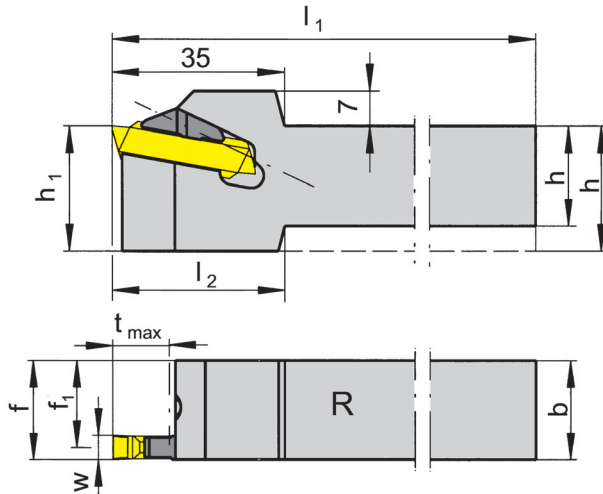

R = right hand version shown

L = left hand version

Part number	h	b	l ₁	l ₂	h ₁	f ₁	f	t _{max}	Size	Clamping range
R/L210.2020.09	20	20	150	35	25	15.2	f ₁ +w/2	11	09	8.1 - 10.4
R/L210.2525.09	25	25	150	-	25	20.2	f ₁ +w/2	11	09	8.1 - 10.4
R/L210.3225.09	32	25	170	-	32	20.2	f ₁ +w/2	11	09	8.1 - 10.4

State R or L version

w see indexable inserts

Dimensions in mm

Further sizes upon request

Note:

Please note type of clamp.

For torque specification of the screw, please see Technical Instructions.

Spare Parts

Toolholder	Clamping element	TORX PLUS® Wrench
L210...	L218.9	T15PQ
R210...	R218.9	T15PQ



Basic toolholder

U218

with changeable cassette

Depth of groove up to
Clamping range

.709"
.118 - .319"

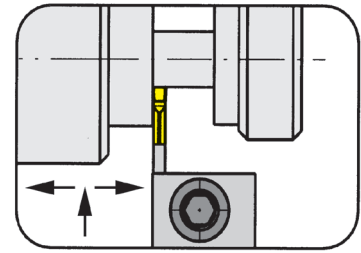

Indexable insert

Type 229
S229
N229

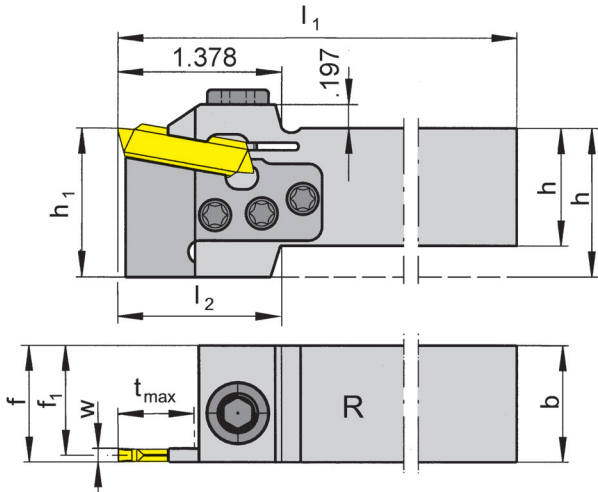

R = right hand version shown

L = left hand version

Part number	h	b	l ₁	l ₂	h ₁	f ₁	f	t _{max}	Size	Clamping range
R/LU218.1000.K3	1.000	1.000	6.004	1.378	1.260	.943	f ₁ +w/2	.709	03	.118 - .157
R/LU218.1250.K3	1.250	1.000	6.693	1.378	1.260	.943	f ₁ +w/2	.709	03	.118 - .157
R/LU218.1000.K4	1.000	1.000	6.004	1.378	1.260	.909	f ₁ +w/2	.709	04	.157 - .197
R/LU218.1250.K4	1.250	1.000	6.693	-	1.250	.909	f ₁ +w/2	.709	04	.157 - .200
R/LU218.1000.K5	1.000	1.000	6.004	1.378	1.260	.890	f ₁ +w/2	.709	05	.201 - .240
R/LU218.1250.K5	1.250	1.000	6.693	1.378	1.260	.890	f ₁ +w/2	.709	05	.201 - .240
R/LU218.1000.K7	1.000	1.000	6.004	1.378	1.260	.850	f ₁ +w/2	.709	07	.240 - .319
R/LU218.1250.K7	1.250	1.000	6.693	-	1.250	.850	f ₁ +w/2	.709	07	.240 - .319

State R or L version

w see indexable inserts

Dimensions in inch

Further sizes upon request

For torque specification of the screw, please see Technical Instructions.

Spare Parts

Basic toolholder	Clamping Screw	Allen wrench	Cassette	TORX PLUS® Wrench
R/LU218...K3	030.0518.T20P	SW6,0 DIN911	NK218.32.03	T20PQ
R/LU218...K4	030.0518.T20P	SW6,0 DIN911	NK218.32.04	T20PQ
R/LU218...K5	030.0518.T20P	SW6,0 DIN911	NK218.32.05	T20PQ
R/LU218...K6	030.0518.T20P	SW6,0 DIN911	NK218.32.07	T20PQ

Grooving and Side Turning (external)



Basic toolholder

218

with changeable cassette

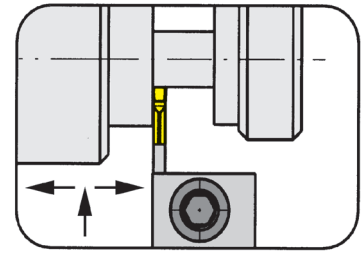

Depth of groove up to 18 mm
Clamping range 3 - 8 mm

Indexable insert

Type 229
S229
N229

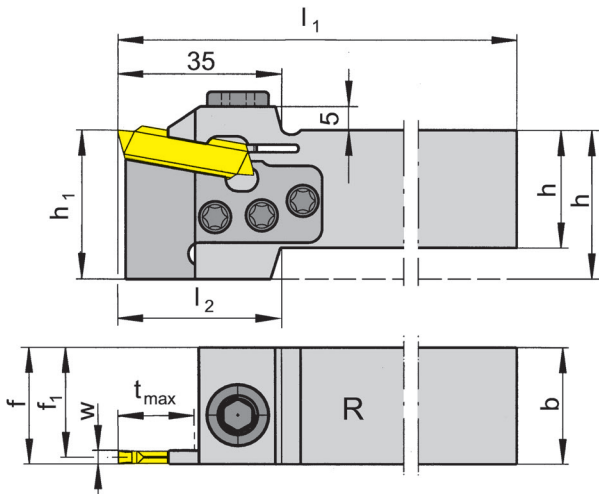

R = right hand version shown

L = left hand version

Part number	h	b	l ₁	l ₂	h ₁	f ₁	f	t _{max}	Size	Clamping range
R/L218.2525.K3	25	25	150	35	32	23.55	f ₁ +w/2	18	03	3.0 - 4.0
R/L218.3225.K3	32	25	170	-	32	23.55	f ₁ +w/2	18	03	3.0 - 4.0
R/L218.2525.K4	25	25	150	35	32	22.70	f ₁ +w/2	18	04	4.0 - 5.0
R/L218.3225.K4	32	25	170	-	32	22.70	f ₁ +w/2	18	04	4.0 - 5.0
R/L218.2525.K5	25	25	150	35	32	22.20	f ₁ +w/2	18	05	5.1 - 6.0
R/L218.3225.K5	32	25	170	-	32	22.20	f ₁ +w/2	18	05	5.1 - 6.0
R/L218.2525.K7	25	25	150	35	32	21.20	f ₁ +w/2	18	07	6.1 - 8.0
R/L218.3225.K7	32	25	170	-	32	21.20	f ₁ +w/2	18	07	6.1 - 8.0

State R or L version

w see indexable inserts

Dimensions in mm

Further sizes upon request

For torque specification of the screw, please see Technical Instructions.

Spare Parts

Basic toolholder	Clamping Screw	Allen wrench	Cassette	TORX PLUS® Wrench
R/L218...K3	030.0518.T20P	SW6,0 DIN911	NK218.32.03	T20PQ
R/L218...K4	030.0518.T20P	SW6,0 DIN911	NK218.32.04	T20PQ
R/L218...K5	030.0518.T20P	SW6,0 DIN911	NK218.32.05	T20PQ
R/L218...K7	030.0518.T20P	SW6,0 DIN911	NK218.32.07	T20PQ



Basic toolholder

U218

with changeable cassette

Depth of groove up to
Clamping range

.709"
.319 - .409"

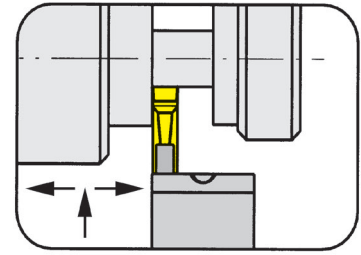

Indexable insert

Type 229
S229
N229

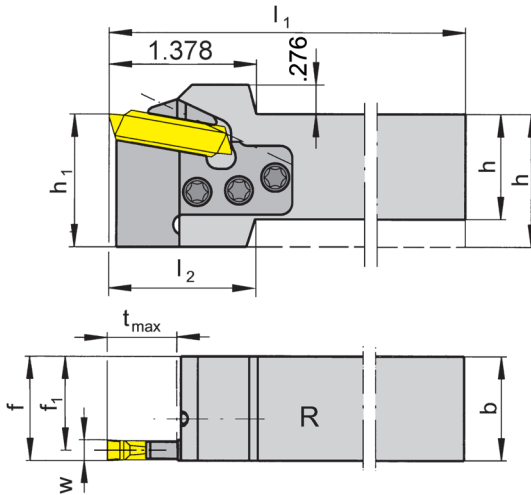

R = right hand version shown

L = left hand version

Part number	h	b	l ₁	l ₂	h ₁	f ₁	f	t _{max}	Size	Clamping range
R/LU218.1000.K9	1.000	1.000	6.004	1.378	1.250	.811	f ₁ +w/2	.709	09	.319 - .409
R/LU218.1250.K9	1.250	1.000	6.693	-	1.250	.811	f ₁ +w/2	.709	09	.319 - .409

State R or L version

w see indexable inserts

Dimensions in inch

Further sizes upon request

Note:

Please note type of clamp.

For torque specification of the screw, please see Technical Instructions.

Spare Parts

Basic toolholder	Clamping Screw	Cassette	Clamping element	TORX PLUS® Wrench
LU218....	030.0518.T20P	NK218.32.09	L218.9	T20PQ
RU218....	030.0518.T20P	NK218.32.09	R218.9	T20PQ

Grooving and Side Turning (external)



Basic toolholder

218

with changeable cassette

Depth of groove up to
Clamping range

18 mm
8.1 - 10.4 mm

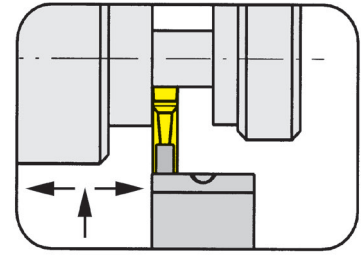

for Indexable insert

Type 229
S229
N229

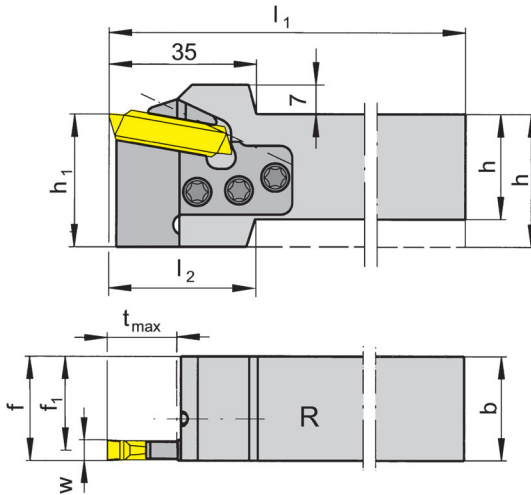

R = right hand version shown

L = left hand version

Part number	h	b	l ₁	l ₂	h ₁	f ₁	f	t _{max}	Size	Clamping range
R/L218.2525.K9	25	25	150	48	32	20.2	f ₁ +w/2	18	09	8.1 - 10.4
R/L218.3225.K9	32	25	170	-	32	20.2	f ₁ +w/2	18	09	8.1 - 10.4

State R or L version

w see indexable inserts

Dimensions in mm

Further sizes upon request

Note:

Please note type of clamp.

For torque specification of the screw, please see Technical Instructions.

Spare Parts

Basic toolholder	Clamping Screw	Cassette	Clamping element	TORX PLUS® Wrench
L218...	030.0518.T20P	NK218.32.09	L218.9	T20PQ
R218...	030.0518.T20P	NK218.32.09	R218.9	T20PQ



Grooving and Side Turning (external)



Toolholder

U218

Depth of groove up to
Clamping range

.709"
.098 - .240"

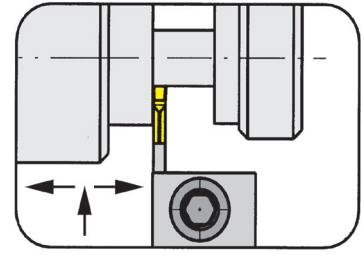

for Indexable insert

Type 229
S229
N229

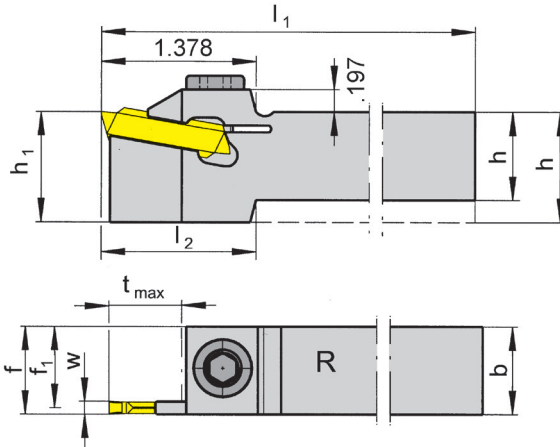

R = right hand version shown

L = left hand version

Part number	h	b	l ₁	l ₂	h ₁	f ₁	f	t _{max}	Size	Clamping range
R/LU218.0750.02	.750	.750	6.004	1.378	1.00	.693	f ₁ +w/2	.709	02	.098 - .118
R/LU218.1000.02	1.000	1.000	6.004	-	1.00	.943	f ₁ +w/2	.709	02	.098 - .118
R/LU218.0625.03	.625	.625	6.004	1.772	1.00	.567	f ₁ +w/2	.709	03	.118 - .157
R/LU218.0750.03	.750	.750	6.004	1.378	1.00	.693	f ₁ +w/2	.709	03	.118 - .157
R/LU218.1000.03	1.000	1.000	6.004	-	1.00	.943	f ₁ +w/2	.709	03	.118 - .157
R/LU218.1250.03	1.250	1.000	6.693	-	1.25	.943	f ₁ +w/2	.709	03	.118 - .157
R/LU218.0750.04	.750	.750	6.004	1.378	1.00	.659	f ₁ +w/2	.709	04	.157 - .200
R/LU218.1000.04	1.000	1.000	6.004	-	1.00	.909	f ₁ +w/2	.709	04	.157 - .200
R/LU218.1250.04	1.250	1.250	6.004	-	1.25	1.159	f ₁ +w/2	.709	04	.157 - .200
R/LU218.0750.05	.750	.750	6.004	1.378	1.00	.640	f ₁ +w/2	.709	05	.201 - .236
R/LU218.1000.05	1.000	1.000	6.004	-	1.00	.890	f ₁ +w/2	.709	05	.201 - .240
R/LU218.1250.05	1.250	1.000	6.693	-	1.25	.890	f ₁ +w/2	.709	05	.201 - .240

State R or L version

w see indexable inserts

Dimensions in inch

R/LU218...02 max. depth of groove up to Ø 3.150"

Further sizes upon request

For torque specification of the screw, please see Technical Instructions.

Spare Parts

Toolholder	Clamping Screw	Allen wrench
R/LU218...	218.3	SW6,0 DIN911

H18

Call Us Toll Free (888) 818-4676

Grooving and Side Turning (external)



Toolholder

218

Depth of groove up to
Clamping range

18 mm
2.5 - 6 mm

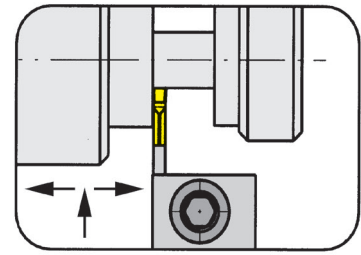

for Indexable insert

Type 229
S229
N229

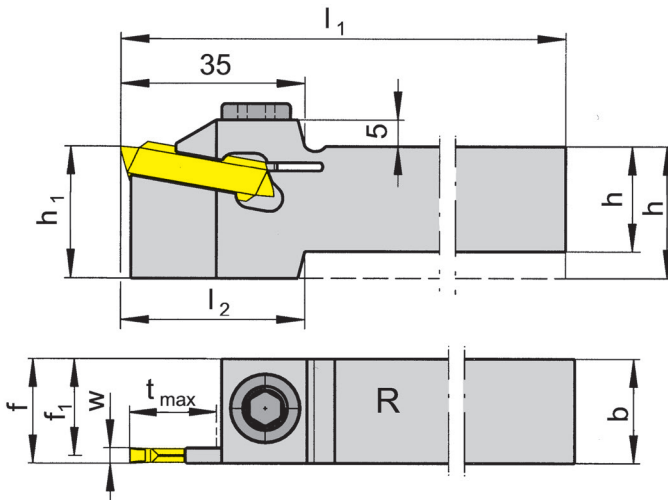

R = right hand version shown

L = left hand version

Part number	h	b	l ₁	l ₂	h ₁	f ₁	f	t _{max}	D _{max}	Size	Clamping range
R/L218.2020.02	20	20	150	35	25	18.55	f ₁ +w/2	18	80	02	2.5 - 3.0
R/L218.2525.02	25	25	150	-	25	23.55	f ₁ +w/2	18	80	02	2.5 - 3.0
R/L218.2020.03	20	20	150	35	25	18.55	f ₁ +w/2	18	-	03	3.0 - 4.0
R/L218.3225.03	32	25	170	-	32	23.55	f ₁ +w/2	18	-	03	3.0 - 4.0
R/L218.1616.03	16	16	150	45	25	14.55	f ₁ +w/2	18	-	03	3.0 - 4.0
R/L218.2525.03	25	25	150	-	25	23.55	f ₁ +w/2	18	-	03	3.0 - 4.0
R/L218.2020.04	20	20	150	35	25	17.70	f ₁ +w/2	18	-	04	4.0 - 5.0
R/L218.2525.04	25	25	150	-	25	22.70	f ₁ +w/2	18	-	04	4.0 - 5.0
R/L218.3225.04	32	25	170	-	32	22.70	f ₁ +w/2	18	-	04	4.0 - 5.0
R/L218.2020.05	20	20	150	35	25	17.20	f ₁ +w/2	18	-	05	5.1 - 6.0
R/L218.2525.05	25	25	150	-	25	22.20	f ₁ +w/2	18	-	05	5.1 - 6.0
R/L218.3225.05	32	25	170	-	32	22.20	f ₁ +w/2	18	-	05	5.1 - 6.0

State R or L version

w see indexable inserts

Dimensions in mm

R/L 218...02 max. depth of groove up to Ø 80 mm

Further sizes upon request

For torque specification of the screw, please see Technical Instructions.

Spare Parts

Toolholder	Clamping Screw	Allen wrench
R/L218...	218.3	SW6,0 DIN911



Grooving and Side Turning (external)



Toolholder

218

Depth of groove up to
Clamping range

18 mm
2.5 - 4 mm

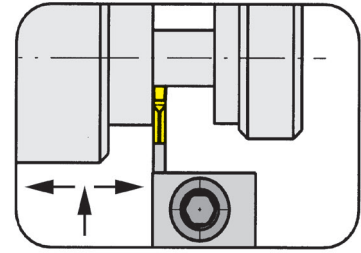

for Indexable insert

Type 229
S229
N229

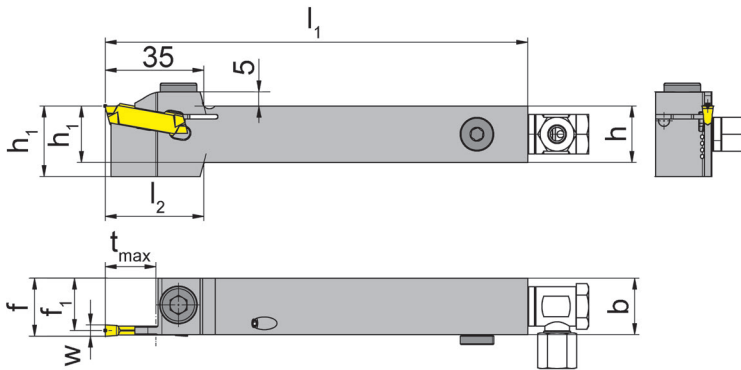

with through coolant supply

R = right hand version shown

L = left hand version

Part number	h	b	l ₁	l ₂	h ₁	f ₁	f	t _{max}	D _{max}	Size	Clamping range
R/L218.2020.02.IK	20	20	150	35	25	18.55	f ₁ +w/2	18	80	02	2.5 - 3.0
R/L218.2525.02.IK	25	25	150	-	25	23.55	f ₁ +w/2	18	80	02	2.5 - 3.0
R/L218.1616.03.IK	16	16	150	45	25	14.55	f ₁ +w/2	18	-	03	3.0 - 4.0
R/L218.2020.03.IK	20	20	150	35	25	18.55	f ₁ +w/2	18	-	03	3.0 - 4.0
R/L218.2525.03.IK	25	25	150	-	25	23.55	f ₁ +w/2	18	-	03	3.0 - 4.0
R/L218.3225.03.IK	32	25	170	-	32	23.55	f ₁ +w/2	18	-	03	3.0 - 4.0

State R or L version

w see indexable inserts

Dimensions in mm

R/L 218...02 max. depth of groove up to Ø 80 mm

Further sizes upon request

For torque specification of the screw, please see Technical Instructions.

Spare Parts

Toolholder	Clamping Screw	Sealing plug	Threaded Pin	Allen wrench	Coolant supply
R/L218...IK	218.3	004.00.26	18.05.913	SW6,0 DIN911	004.00.16

H20

Call Us Toll Free (888) 818-4676

H

Toolholder

218

with screwed clamping

Depth of groove up to
Width of groove

18 mm
3 - 6 mm

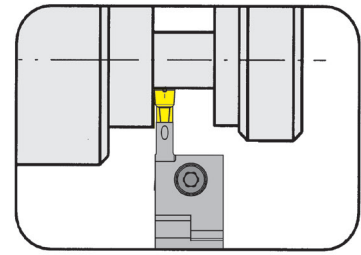

for Indexable insert

Type 229
S229
N229

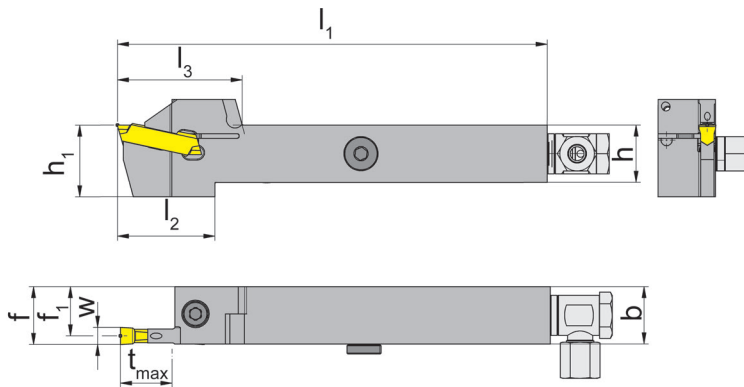

with through coolant supply

R = right hand version shown

L = left hand version

Part number	h	b	l ₁	l ₂	l ₃	h ₁	f ₁	f	t _{max}	Size
R/L218.1616.0.03.IK	16	16	150	37	43.5	25	14.55	f ₁ +w/2	18	03
R/L218.2020.0.03.IK	20	20	150	34	43.5	25	18.55	f ₁ +w/2	18	03
R/L218.2525.0.03.IK	25	25	150	32	43.5	32	23.55	f ₁ +w/2	18	03
R/L218.2020.0.04.IK	20	20	150	34	43.5	25	17.70	f ₁ +w/2	18	04
R/L218.2525.0.04.IK	25	25	150	32	43.5	32	22.70	f ₁ +w/2	18	04
R/L218.2020.0.05.IK	20	20	150	34	43.5	25	17.20	f ₁ +w/2	18	05
R/L218.2525.0.05.IK	25	25	150	32	43.5	32	22.20	f ₁ +w/2	18	05

State R or L version

w see indexable inserts

Dimensions in mm

Further sizes upon request

For torque specification of the screw, please see Technical Instructions.

Spare Parts

Toolholder	Sealing plug	Threaded Pin	Coolant supply	Clamping Screw	TORX PLUS® Wrench
R/L218...IK	004.00.26	18.05.913	004.00.16	6.23T25P	T25PQ

Grooving and Side Turning (external)



Toolholder

U218

Depth of groove up to $1''$
Clamping range $.240 - .319''$

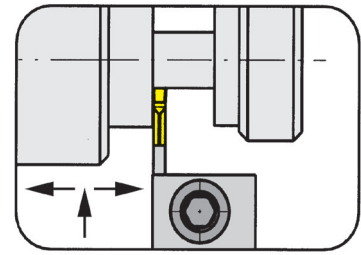

for Indexable insert

Type 229
S229
N229

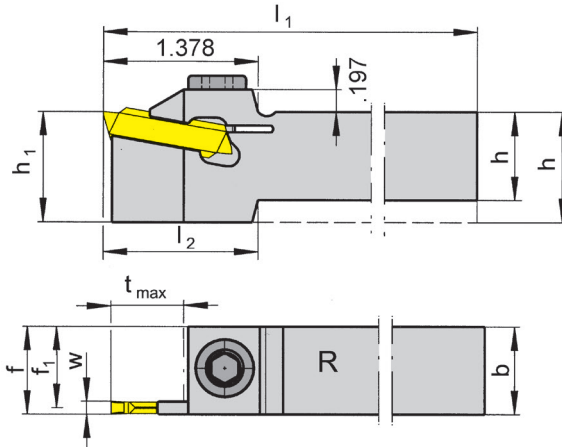

R = right hand version shown

L = left hand version

Part number	h	b	l_1	l_2	h_1	f_1	f	t_{max}	Size	Clamping range
R/LU218.0750.07	.750	.750	6.004	1.378	.984	.600	$f_1+w/2$.709	07	.240 - .319
R/LU218.1000.07	1.000	1.000	6.004	-	1.000	.848	$f_1+w/2$.709	07	.240 - .315
R/LU218.1250.07	1.250	1.000	6.693	-	1.250	.850	$f_1+w/2$.709	07	.240 - .319

State R or L version

w see indexable inserts

Dimensions in inch

Further sizes upon request

For torque specification of the screw, please see Technical Instructions.

Spare Parts

Toolholder	Clamping Screw	Allen wrench
R/LU218...	218.3	SW6,0 DIN911

Toolholder

218

Depth of groove up to
Clamping range

18 mm
6.1 - 8 mm

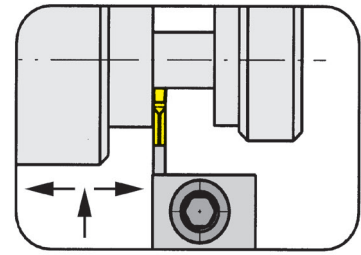

for Indexable insert

Type 229
S229
N229

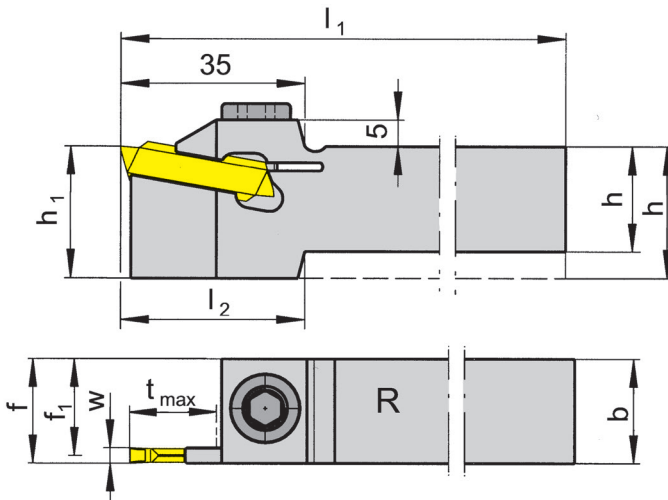

R = right hand version shown

L = left hand version

Part number	h	b	l_1	l_2	h_1	f_1	f	t_{max}	Size	Clamping range
R/L218.2020.07	20	20	150	35	25	16.2	$f_1+w/2$	18	07	6.1 - 8.0
R/L218.2525.07	25	25	150	-	25	21.2	$f_1+w/2$	18	07	6.1 - 8.0
R/L218.3225.07	32	25	170	-	32	21.2	$f_1+w/2$	18	07	6.1 - 8.0
R/L218.2525.08	25	25	150	-	25	21.2	$f_1+w/2$	18	08	7.6 - 8.0

State R or L version

w see indexable inserts

Dimensions in mm

Further sizes upon request

For torque specification of the screw, please see Technical Instructions.

Spare Parts

Toolholder	Clamping Screw	Allen wrench
R/L218...	218.3	SW6,0 DIN911



Toolholder

U218

Depth of groove up to
Clamping range

.709"
.319 - .413"

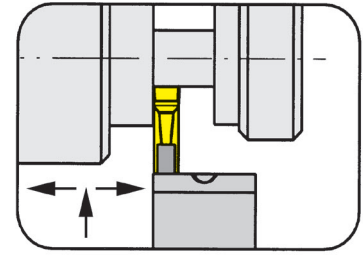

for Indexable insert

Type 229
S229
N229

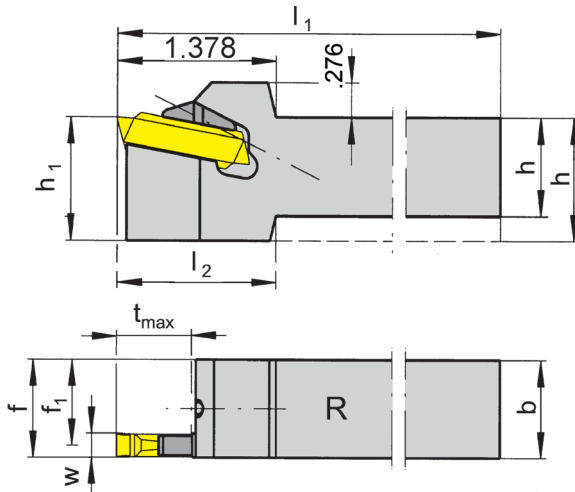

R = right hand version shown

L = left hand version

Part number	h	b	l ₁	h ₁	f ₁	f	t _{max}	Size	Clamping range
R/LU218.0750.09	.750	.750	6.004	1.000	.561	f ₁ +w/2	.709	09	.319 - .413
R/LU218.1000.09	1.000	1.000	6.004	1.000	.811	f ₁ +w/2	.709	09	.319 - .409
R/LU218.1250.09	1.250	1.000	6.693	1.250	.811	f ₁ +w/2	.709	09	.319 - .413

State R or L version

w see indexable inserts

Dimensions in inch

Further sizes upon request

Note:

Please note type of clamp.

For torque specification of the screw, please see Technical Instructions.

Spare Parts

Toolholder	Clamping element	TORX PLUS® Wrench
LU218...	L218.9	T15PQ
RU218...	R218.9	T15PQ

Grooving and Side Turning (external)



Toolholder

218

Depth of groove up to
Clamping range

18 mm
8.1 - 10.4 mm

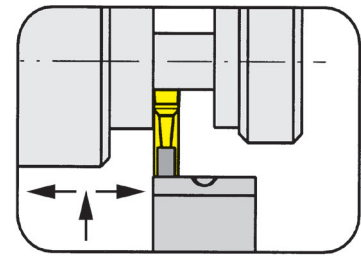

for Indexable insert

Type 229
S229
N229

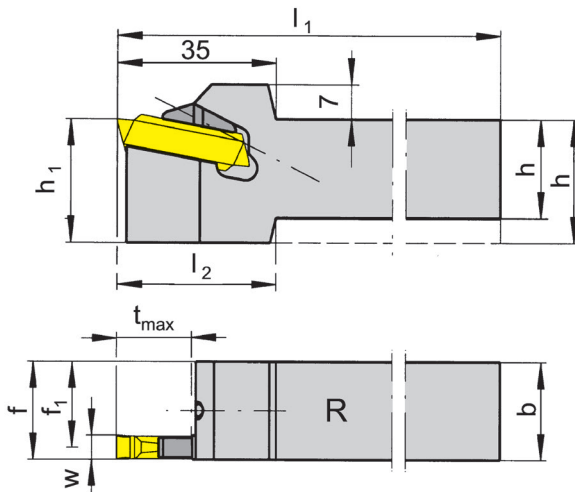

R = right hand version shown

L = left hand version

Part number	h	b	l_1	l_2	h_1	f_1	f	t_{max}	Size	Clamping range
R/L218.2020.09	20	20	150	35	25	15.2	$f_1+w/2$	18	09	8.1 - 10.4
R/L218.2525.09	25	25	150	-	25	20.2	$f_1+w/2$	18	09	8.1 - 10.4
R/L218.3225.09	32	25	170	-	32	20.2	$f_1+w/2$	18	09	8.1 - 10.4

State R or L version

w see indexable inserts

Dimensions in mm

Further sizes upon request

Note:

Please note type of clamp.

For torque specification of the screw, please see Technical Instructions.

Spare Parts

Toolholder	Clamping element	TORX PLUS® Wrench
L218...	L218.9	T15PQ
R218...	R218.9	T15PQ

Toolholder

U226

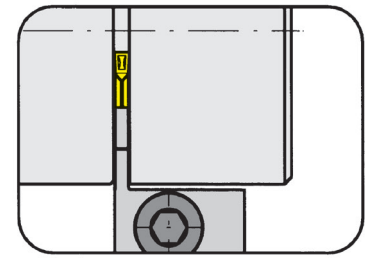

Depth of groove up to $1''$
Clamping range .118 - .236''

for Indexable insert

Type 229
S229
N229

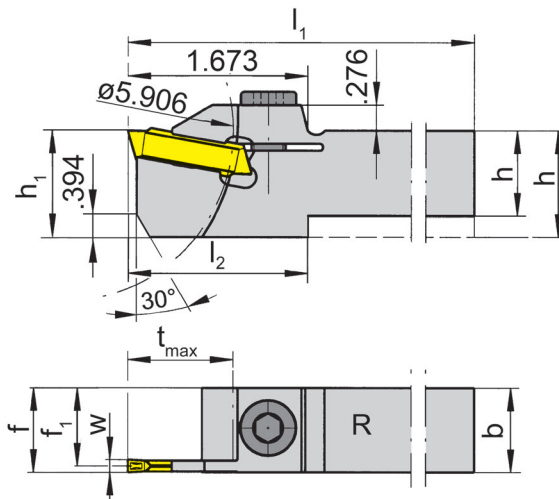

R = right hand version shown

L = left hand version

Part number	h	b	l ₁	l ₂	h ₁	f ₁	f	t _{max}	Size	Clamping range
R/LU226.0625.03	.625	.625	6.004	2.000	1.250	.568	f ₁ +w/2	1.000	03	.118 - .157
R/LU226.0750.03	.750	.750	6.004	1.673	1.250	.693	f ₁ +w/2	1.000	03	.118 - .157
R/LU226.1000.03	1.000	1.000	6.004	1.673	1.250	.943	f ₁ +w/2	1.000	03	.118 - .157
R/LU226.1250.03	1.250	1.000	6.693	-	1.250	.943	f ₁ +w/2	1.000	03	.118 - .157
R/LU226.0625.04	.625	.625	6.004	2.000	1.250	.534	f ₁ +w/2	1.000	04	.157 - .200
R/LU226.0750.04	.750	.750	6.004	1.673	1.250	.659	f ₁ +w/2	1.000	04	.157 - .200
R/LU226.1000.04	1.000	1.000	6.004	1.673	1.260	.909	f ₁ +w/2	.984	04	.157 - .200
R/LU226.1250.04	1.250	1.000	6.693	-	1.250	.909	f ₁ +w/2	1.000	04	.157 - .197
R/LU226.0750.05	.750	.750	6.004	1.673	1.260	.640	f ₁ +w/2	.984	05	.201 - .236
R/LU226.1000.05	1.000	1.000	6.004	1.673	1.250	.890	f ₁ +w/2	1.000	05	.201 - .236
R/LU226.1250.05	1.250	1.000	6.693	-	1.250	.890	f ₁ +w/2	.984	05	.201 - .236

State R or L version

w see indexable inserts

Dimensions in inch

Further sizes upon request

For torque specification of the screw, please see Technical Instructions.

Spare Parts

Toolholder	Clamping Screw	Allen wrench
R/LU226...	218.3	SW6,0 DIN911

Grooving (external)



Toolholder

226

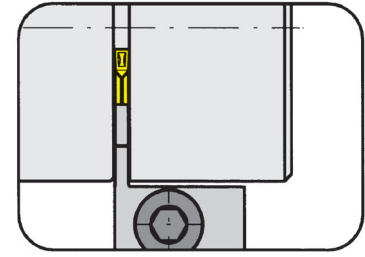

Depth of groove up to 25 mm
Clamping range 3 - 6 mm

for Indexable insert

Type 229
S229
N229

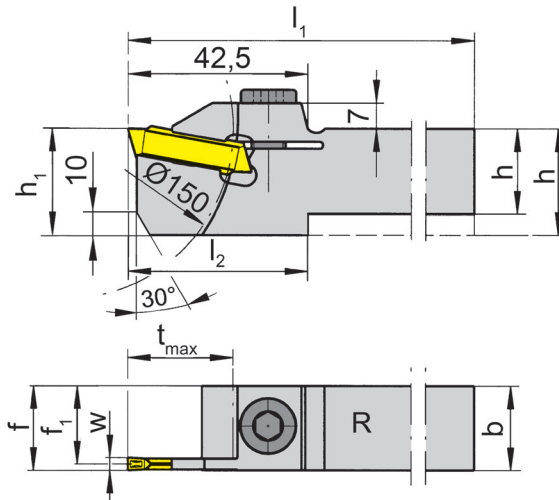

R = right hand version shown

L = left hand version

Part number	h	b	l ₁	l ₂	h ₁	f ₁	f	t _{max}	Size	Clamping range
R/L226.1616.03	16	16	150	52.5	32	18.55	f ₁ +w/2	25	03	3.0 - 4.0
R/L226.2020.03	20	20	150	42.5	32	18.55	f ₁ +w/2	25	03	3.0 - 4.0
R/L226.2525.03	25	25	150	-	32	23.55	f ₁ +w/2	25	03	3.0 - 4.0
R/L226.3225.03	32	25	170	-	32	23.55	f ₁ +w/2	25	03	3.0 - 4.0
R/L226.1616.04	16	16	150	52.5	32	13.70	f ₁ +w/2	25	04	4.0 - 5.0
R/L226.2020.04	20	20	150	42.5	32	17.70	f ₁ +w/2	25	04	4.0 - 5.0
R/L226.2525.04	25	25	150	-	32	22.70	f ₁ +w/2	25	04	4.0 - 5.0
R/L226.3225.04	32	25	170	-	32	22.70	f ₁ +w/2	25	04	4.0 - 5.0
R/L226.2020.05	20	20	150	42.5	32	17.20	f ₁ +w/2	25	05	5.1 - 6.0
R/L226.2525.05	25	25	150	42.5	32	22.20	f ₁ +w/2	25	05	5.1 - 6.0
R/L226.3225.05	32	25	170	-	32	22.20	f ₁ +w/2	25	05	5.1 - 6.0

State R or L version

w see indexable inserts

Dimensions in mm

Further sizes upon request

For torque specification of the screw, please see Technical Instructions.

Spare Parts

Toolholder	Clamping Screw	Allen wrench
R/L226...	218.3	SW6,0 DIN911



Toolholder

226

with screwed clamping

Depth of groove up to
Width of groove

25 mm
3 - 5 mm

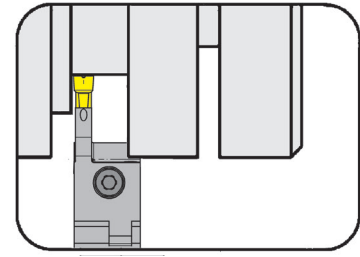

for Indexable insert

Type 229
S229
N229

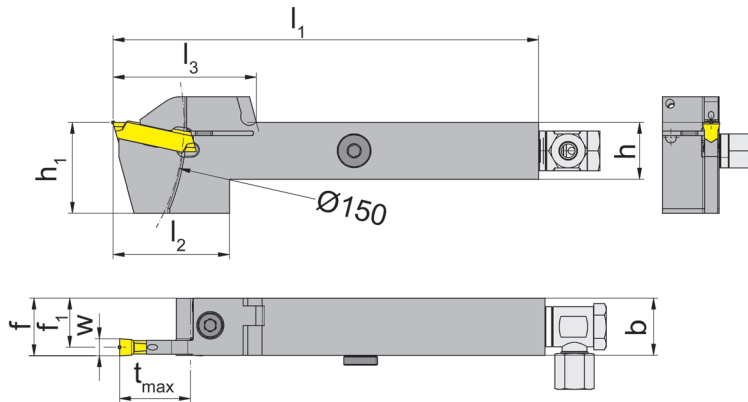

with through coolant supply

R = right hand version shown

L = left hand version

Part number	h	b	l ₁	l ₂	l ₃	h ₁	f ₁	f	t _{max}	Size
R/L226.2020.0.03.IK	20	20	150	41	50.5	32	18.55	f ₁ +w/2	25	03
R/L226.2525.0.03.IK	25	25	150	39	50.5	32	23.55	f ₁ +w/2	25	03
R/L226.2020.0.04.IK	20	20	150	41	50.5	32	17.70	f ₁ +w/2	25	04
R/L226.2525.0.04.IK	25	25	150	39	50.5	32	22.70	f ₁ +w/2	25	04
R/L226.2020.0.05.IK	20	20	150	41	50.5	32	17.20	f ₁ +w/2	25	05
R/L226.2525.0.05.IK	25	25	150	39	50.5	32	22.20	f ₁ +w/2	25	05

State R or L version

w see indexable inserts

Dimensions in mm

Further sizes upon request

For torque specification of the screw, please see Technical Instructions.

Spare Parts

Toolholder	Sealing plug	Threaded Pin	Coolant supply	Clamping Screw	TORX PLUS® Wrench
R/L226...	004.00.26	18.05.913	004.00.16	6.23T25P	T25PQ

Grooving (external)



Toolholder

U226

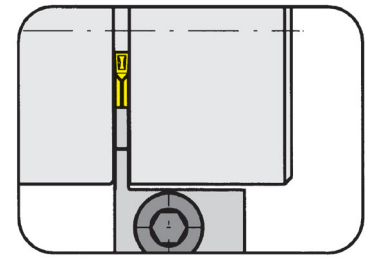

Depth of groove up to $1''$
Clamping range .240 - .319''

for Indexable insert

Type 229
S229
N229

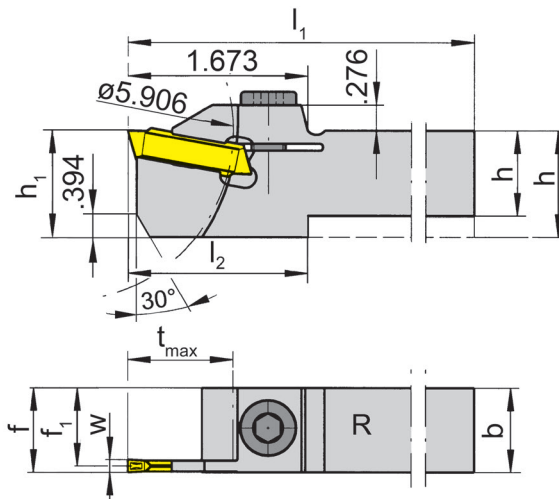

R = right hand version shown

L = left hand version

Part number	h	b	l_1	l_2	h_1	f_1	f	t_{max}	Size	Clamping range
R/LU226.1000.07	1.000	1.000	6.004	1.673	1.250	.850	$f_1+w/2$	1.000	07	.240 - .319
R/LU226.1250.07	1.250	1.000	6.693	-	1.250	.850	$f_1+w/2$	1.000	07	.240 - .315
LU226.1000.08	1.000	1.000	6.004	1.673	1.250	.850	$f_1+w/2$	1.000	08	.280 - .319

State R or L version

w see indexable inserts

Dimensions in inch

Further sizes upon request

For torque specification of the screw, please see Technical Instructions.

Spare Parts

Toolholder	Clamping Screw	Allen wrench
R/LU226...	218.3	SW6,0 DIN911



Grooving (external)



Toolholder

226

Depth of groove up to 25 mm
Clamping range 6.1 - 8 mm

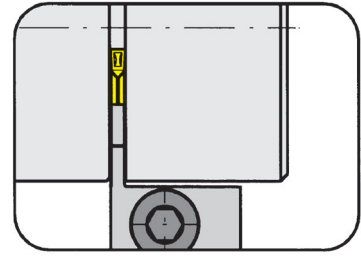

for Indexable insert

Type 229
S229
N229

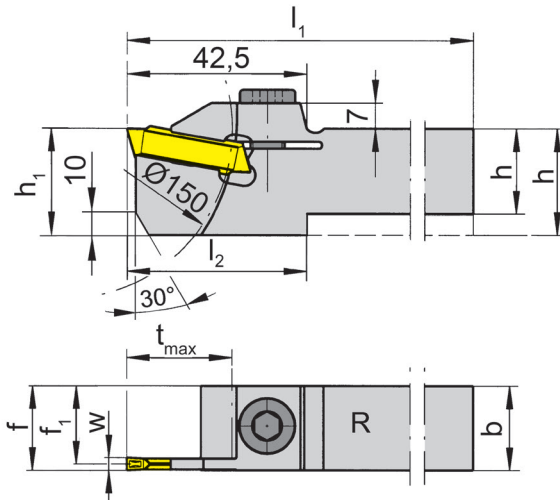

R = right hand version shown

L = left hand version

Part number	h	b	l ₁	l ₂	h ₁	f ₁	f	t _{max}	Size	Clamping range
R/L226.2525.07	25	25	150	42.5	32	21.2	f ₁ +w/2	25	07	6.1 - 8.0
R/L226.3225.07	32	25	170	-	32	21.2	f ₁ +w/2	25	07	6.1 - 8.0
R/L226.2525.08	25	25	150	42.5	32	20.2	f ₁ +w/2	25	08	7.6 - 8.0
R/L226.3225.08	32	25	170	-	32	21.2	f ₁ +w/2	25	08	7.6 - 8.0

State R or L version

w see indexable inserts

Dimensions in mm

Further sizes upon request

For torque specification of the screw, please see Technical Instructions.

Spare Parts

Toolholder	Clamping Screw	Allen wrench
R/L226...	218.3	SW6,0 DIN911

H30

Call Us Toll Free (888) 818-4676

H

Grooving (external)



Toolholder

U226

Depth of groove up to $1''$
Clamping range .319 - .409"

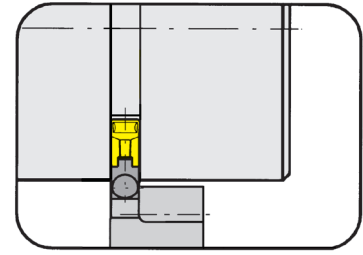

for Indexable insert

Type 229
S229
N229

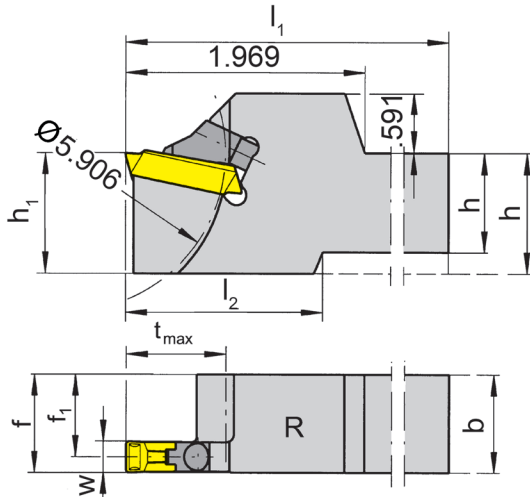

R = right hand version shown

L = left hand version

Part number	h	b	l ₁	l ₂	h ₁	f ₁	f	t _{max}	Size	Clamping range
R/LU226.1000.09	1.000	1.000	6.004	1.969	1.250	.811	f ₁ +w/2	1.000	09	.319 - .409
R/LU226.1250.09	1.250	1.000	6.693	-	1.250	.811	f ₁ +w/2	1.000	09	.319 - .409

State R or L version

w see indexable inserts

Dimensions in inch

Further sizes upon request

For torque specification of the screw, please see Technical Instructions.

Spare Parts

Toolholder	Clamping element	TORX PLUS® Wrench
R/LU226...	020.1008.0041	T15PQ



Grooving (external)



Toolholder

226

Depth of groove up to
Clamping range

25 mm
8.1 - 10.4 mm

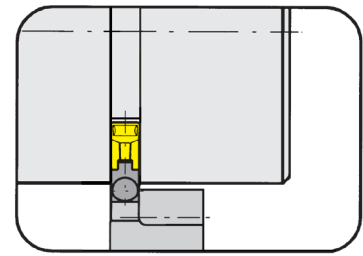

for Indexable insert

Type 229
S229
N229

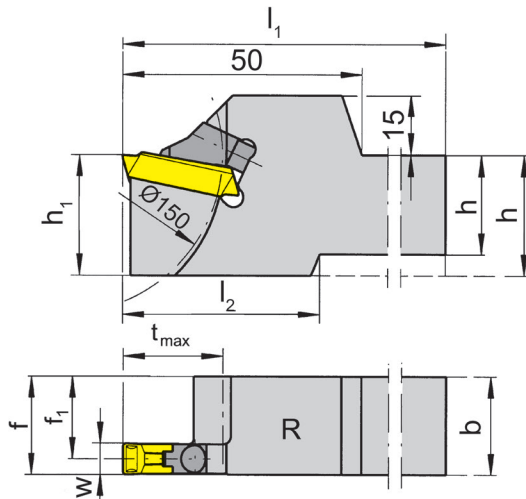

R = right hand version shown

L = left hand version

Part number	h	b	l ₁	l ₂	h ₁	f ₁	f	t _{max}	Size	Clamping range
R/L226.2525.09	25	25	150	42.5	32	20.2	f ₁ +w/2	25	09	8.1 - 10.4
R/L226.3225.09	32	25	170	-	32	20.2	f ₁ +w/2	25	09	8.1 - 10.4

State R or L version

w see indexable inserts

Dimensions in mm

Further sizes upon request

For torque specification of the screw, please see Technical Instructions.

Spare Parts

Toolholder	Clamping element	TORX PLUS® Wrench
R/L226...	020.1008.0041	T15PQ

H32

Call Us Toll Free (888) 818-4676

H

Toolholder

U219

Depth of groove up to .591"
Clamping range .118 - .319"

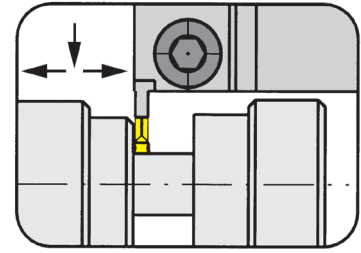

for Indexable insert

Type 229
S229
N229

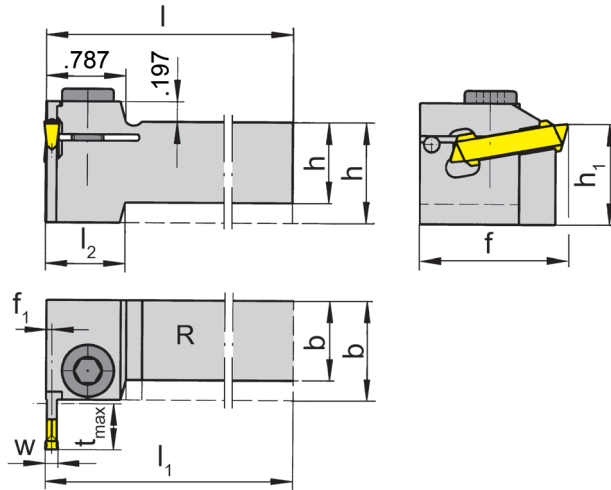

R = right hand version shown

L = left hand version

Part number	h	b	l	l_1	h_1	f	t_{max}	Size	Clamping range
R/LU219.0750.03	.750	.750	6.004	$l-f_1+w/2$	1	1.472	.433	03	.118 - .157
R/LU219.1000.03	1.000	1.000	6.004	$l-f_1+w/2$	1	1.472	.433	03	.118 - .157
R/LU219.0750.04	.750	.750	6.004	$l-f_1+w/2$	1	1.472	.433	04	.157 - .200
R/LU219.1000.04	1.000	1.000	6.004	$l-f_1+w/2$	1	1.472	.433	04	.157 - .200
R/LU219.0750.05	.750	.750	6.004	$l-f_1+w/2$	1	1.772	.591	05	.201 - .240
R/LU219.1000.05	1.000	1.000	6.004	$l-f_1+w/2$	1	1.772	.591	05	.201 - .240
R/LU219.0750.07	.750	.750	6.004	$l-f_1+w/2$	1	1.772	.591	07	.240 - .319
R/LU219.1000.07	1.000	1.000	6.004	$l-f_1+w/2$	1	1.772	.591	07	.240 - .319

State R or L version

w see indexable inserts

Dimensions in inch

Further sizes upon request

For torque specification of the screw, please see Technical Instructions.

Spare Parts

Toolholder	Clamping Screw	Allen wrench
R/LU219...	218.3	SW6,0 DIN911



Grooving and Side Turning (external)



Toolholder

219

Depth of groove up to
Clamping range

15 mm
3 - 8 mm

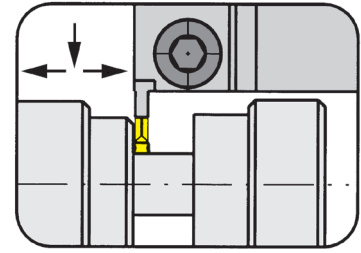

for Indexable insert

Type 229
S229
N229

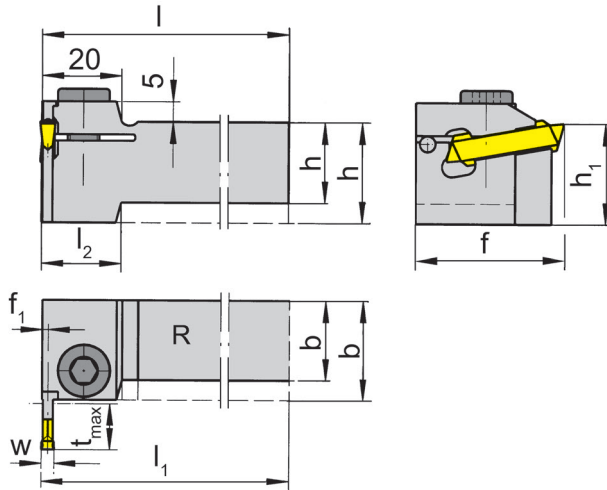

R = right hand version shown

L = left hand version

Part number	h	b	l	l_1	l_2	h_1	f	f_1	t_{max}	Size	Clamping range
R/L219.2020.03	20	20	150	$l-f_1+w/2$	20	25	37	1.45	11	03	3.0 - 4.0
R/L219.2525.03	25	25	150	$l-f_1+w/2$	-	25	37	1.45	11	03	3.0 - 4.0
R/L219.2020.04	20	20	150	$l-f_1+w/2$	20	25	37	2.30	11	04	4.0 - 5.0
R/L219.2525.04	25	25	150	$l-f_1+w/2$	-	25	37	2.30	11	04	4.0 - 5.0
R/L219.2020.05	20	20	150	$l-f_1+w/2$	23	25	45	2.80	15	05	5.1 - 6.0
R/L219.2525.05	25	25	150	$l-f_1+w/2$	-	25	45	2.80	15	05	5.1 - 6.0
R/L219.2020.07	20	20	150	$l-f_1+w/2$	23	25	45	3.80	15	07	6.1 - 8.0
R/L219.2525.07	25	25	150	$l-f_1+w/2$	-	25	45	3.80	15	07	6.1 - 8.0

State R or L version

w see indexable inserts

Dimensions in mm

Further sizes upon request

For torque specification of the screw, please see Technical Instructions.

Spare Parts

Toolholder	Clamping Screw	Allen wrench
R/L219...	218.3	SW6,0 DIN911

Toolholder

U219

Depth of groove up to
Width of groove

.591"
.319 - .413"

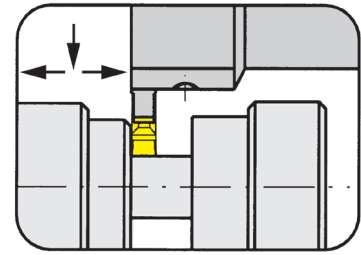

for Indexable insert

Type 229
S229
N229

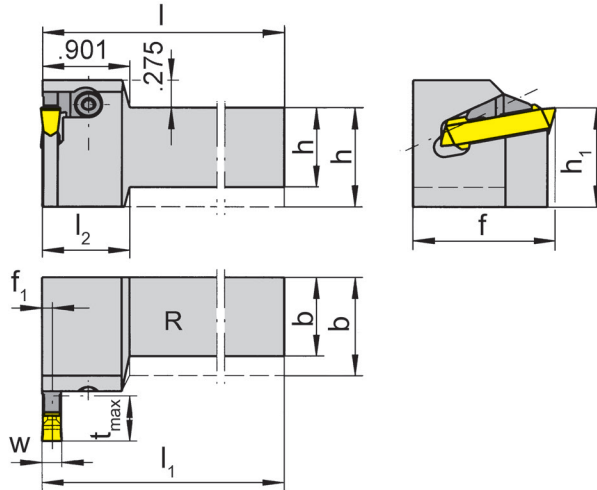

R = right hand version shown

L = left hand version

Part number	h	b	l	l_1	h_1	f	t_{max}	Size	Clamping range
R/LU219.0750.09	.750	.750	6.004	$l-f_1+w/2$	1	1.772	.591	09	.319 - .413
R/LU219.1000.09	1.000	1.000	6.004	$l-f_1+w/2$	1	1.772	.591	09	.319 - .413

State R or L version

w see indexable inserts

Dimensions in inch

Further sizes upon request

Note:

Please note type of clamp.

For torque specification of the screw, please see Technical Instructions.

Spare Parts

Toolholder	Clamping element	TORX PLUS® Wrench
LU219...	L218.9.32	T15PQ
RU219...	R218.9.32	T15PQ

Grooving and Side Turning (external)



Toolholder

219

Depth of groove up to
Width of groove

15 mm
8.1 - 10.4 mm

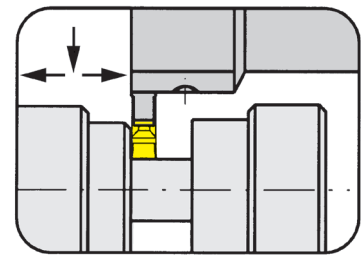

for Indexable insert

Type 229
S229
N229

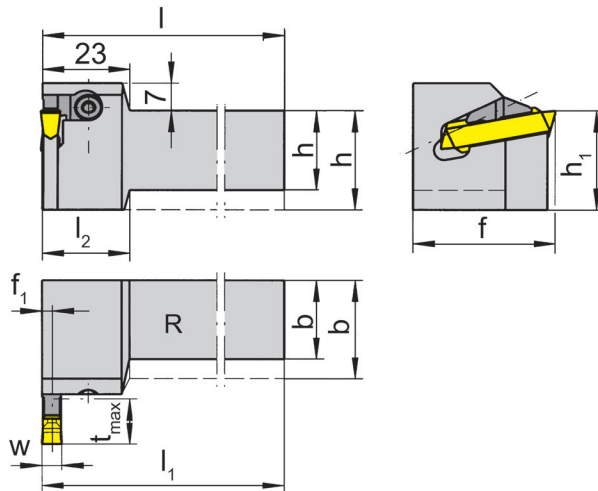

R = right hand version shown

L = left hand version

Part number	h	b	l	l_1	l_2	h_1	f	f_1	t_{max}	Size	Clamping range
R/L219.2020.09	20	20	150	$l-f_1+w/2$	23	25	45	4.8	15	09	8.1 - 10.4
R/L219.2525.09	25	25	150	$l-f_1+w/2$	-	25	45	4.8	15	09	8.1 - 10.4

State R or L version

w see indexable inserts

Dimensions in mm

Further sizes upon request

Note:

Please note type of clamp.

For torque specification of the screw, please see Technical Instructions.

Spare Parts

Toolholder	Clamping element	TORX PLUS® Wrench
L219....	R218.9.32	T15PQ
R219....	L218.9.32	T15PQ

H36

Call Us Toll Free (888) 818-4676

H

Grooving Corner Reliefs (external)



Toolholder

U225

Width of groove .118 - .197"

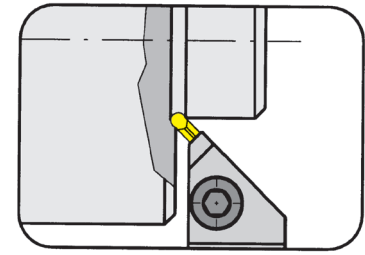

for Indexable insert

Type 229
S229

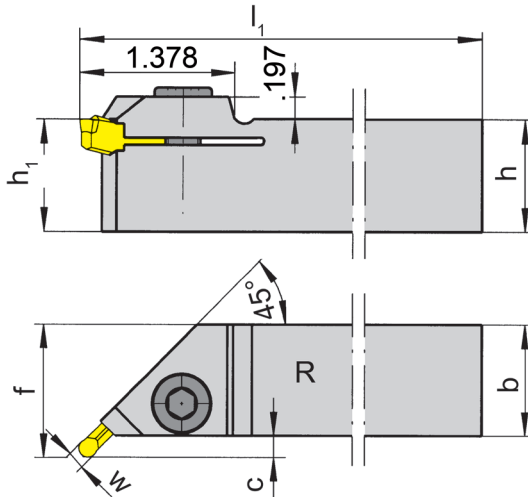

R = right hand version shown

L = left hand version

only for full radius inserts
S229...K

Part number	h	b	l ₁	h ₁	f	C	D _{min}	Width of groove
R/LU225.1000.04	1.000	1.000	6.004	1.000	1.197	.197	1.969	.118 - .197

State R or L version

w see indexable inserts

Dimensions in inch

Further sizes upon request

For torque specification of the screw, please see Technical Instructions.

Revision Factor Δl_1 , Δc , and Δf in relation to the radius r

r	Δl_1	Δc	Δf
.098 - .118	0	0	0
.078	-.0058	-.0058	-.0058
.059	-.0115	-.0115	-.0115

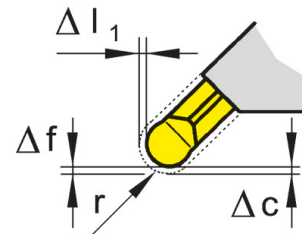

Spare Parts

Toolholder	Clamping Screw	Allen wrench
R/LU225.1000.04	218.3	SW6,0 DIN911



Grooving Corner Reliefs (external)



Toolholder

225

Width of groove 3 - 6 mm

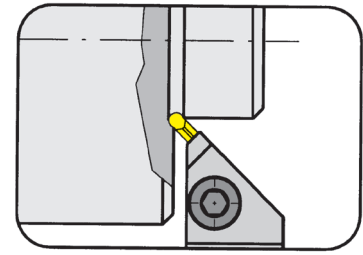

for Indexable insert

Type 229
S229

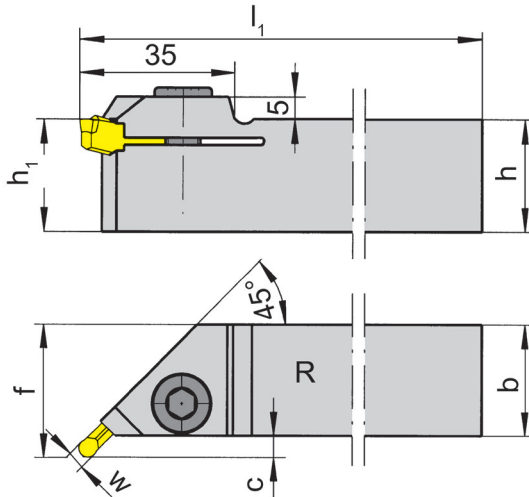

R = right hand version shown

L = left hand version

only for full radius inserts
S229...K

Part number	h	b	l ₁	h ₁	f	C	D _{min}	Width of groove
R/L225.2525.04	25	25	150	25	30.0	5.0	50	3.0 - 5.0
R/L225.2525.05	25	25	150	25	30.5	5.5	50	5.1 - 6.0

State R or L version

w see indexable inserts

Dimensions in mm

Further sizes upon request

For torque specification of the screw, please see Technical Instructions.

Revision Factor Δl_1 , Δc , and Δf in relation to the radius r

r	Δl_1	Δc	Δf
2.5 - 3.0	0	0	0
2.0	-0.147	-0.147	-0.147
1.5	-0.293	-0.293	-0.293

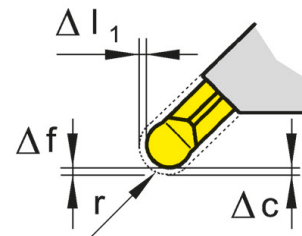

Spare Parts

Toolholder	Clamping Screw	Allen wrench
R/L225...	218.3	SW6,0 DIN911

H38

Call Us Toll Free (888) 818-4676



Grooving and Side Turning (internal)



Toolholder

213

Short style

Bore \varnothing from
Depth of groove up to
Clamping range

46 mm
11.5 mm
3 - 6 mm

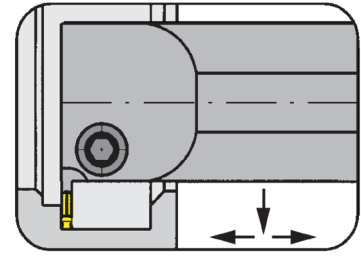

Indexable insert

Type 229
S229
N229

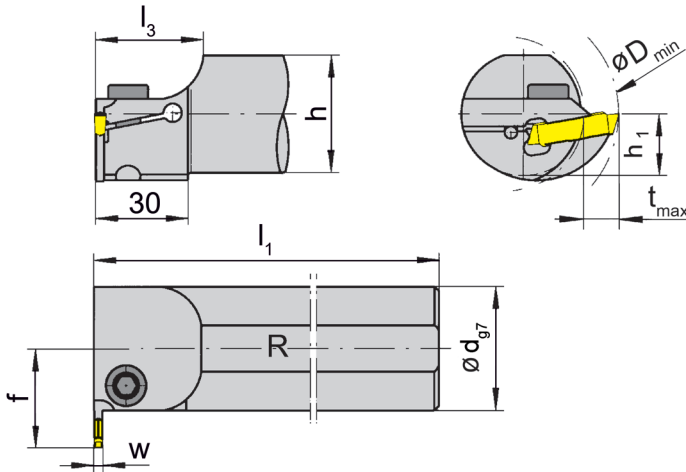

R = right hand version shown

L = left hand version

Part number	d	l ₁	l ₃	h	h ₁	f	t _{max}	D _{min}	Size	Clamping range
R/L213.0032.0.03	32	150	35.0	30	15	28	11.5	46	03	3.0 - 4.0
R/L213.0040.0.03	40	180	39.4	38	19	32	11.5	54	03	3.0 - 4.0
R/L213.0032.0.04	32	150	35.0	30	15	28	11.5	46	04	4.0 - 5.0
R/L213.0040.0.04	40	180	39.4	38	19	32	11.5	54	04	4.0 - 5.0
R/L213.0032.0.05	32	150	35.0	30	15	28	11.5	46	05	5.1 - 6.0
R/L213.0040.0.05	40	180	39.4	38	19	32	11.5	54	05	5.1 - 6.0

State R or L version

w see indexable inserts

Dimensions in mm

Further sizes upon request

For torque specification of the screw, please see Technical Instructions.

Spare Parts

Toolholder	Clamping Screw	Allen wrench
R/L213...	218.3	SW6,0 DIN911



Grooving and Side Turning (internal)



Toolholder

U213

Short style

Bore Ø from
Depth of groove up to
Clamping range

1.496"
.591"
.118 - .319"

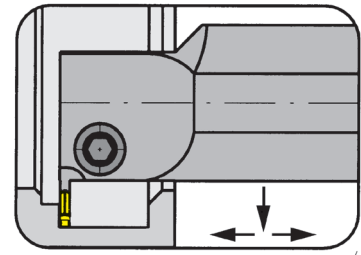

Indexable insert

Type 229
S229
N229

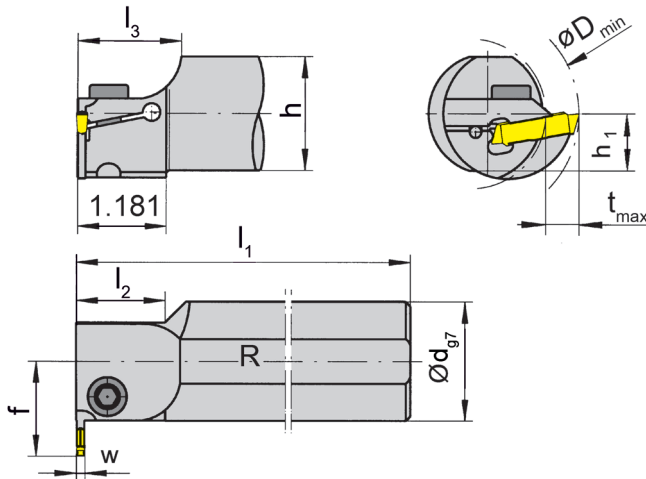

R = right hand version shown

L = left hand version

Part number	d	l ₁	l ₂	l ₃	h	h ₁	f	t _{max}	D _{min}	Size	Clamping range
R/LU213.1000.03	1.000	5.984	1.181	1.375	.921	.461	.965	.453	1.496	03	.118 - .157
R/LU213.1250.03	1.250	5.984	1.181	1.375	1.171	.586	1.102	.453	1.496	03	.118 - .157
R/LU213.1500.03	1.500	7.008	1.181	1.375	1.421	.711	1.220	.453	1.969	03	.118 - .157
R/LU213.2000.03	2.000	7.992	1.181	1.500	1.882	.941	1.614	.591	2.362	03	.118 - .157
R/LU213.1000.04	1.000	5.984	1.181	1.375	.921	.461	.965	.453	1.496	04	.157 - .200
R/LU213.1250.04	1.250	5.984	1.181	1.375	1.171	.586	1.102	.453	1.496	04	.157 - .200
R/LU213.1500.04	1.500	7.008	1.181	1.375	1.421	.711	1.220	.453	1.969	04	.157 - .200
R/LU213.2000.04	2.000	7.992	1.181	1.500	1.882	.941	1.614	.591	2.362	04	.157 - .200
R/LU213.1250.05	1.250	5.984	1.181	1.375	1.171	.586	1.102	.453	1.811	05	.201 - .240
R/LU213.1500.05	1.500	7.008	1.181	1.375	1.421	.711	1.220	.453	1.969	05	.201 - .240
R/LU213.2000.05	2.000	7.992	1.181	1.500	1.882	.941	1.614	.591	2.362	05	.201 - .240
R/LU213.1500.07	1.500	7.008	1.181	1.375	1.421	.711	1.220	.453	1.969	07	.240 - .319
R/LU213.2000.07	2.000	7.992	1.181	1.500	1.882	.941	1.614	.591	2.362	07	.240 - .319

State R or L version

w see indexable inserts

Dimensions in inch

Further sizes upon request

Note Toolholders with shank Ø 1.250":

The full depth of cut $t_{max} = .453"$ will be reached from $D_{min} 1.811"$

For torque specification of the screw, please see Technical Instructions.

Spare Parts

Toolholder	Clamping Screw	Allen wrench
R/LU213...	218.3	SW6,0 DIN911

Grooving and Side Turning (internal)



Toolholder

213

Short style

Bore \varnothing from
Depth of groove up to
Clamping range

38 mm
15 mm
3 - 8 mm

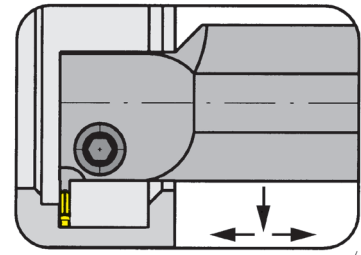

for Indexable insert

Type 229
S229
N229

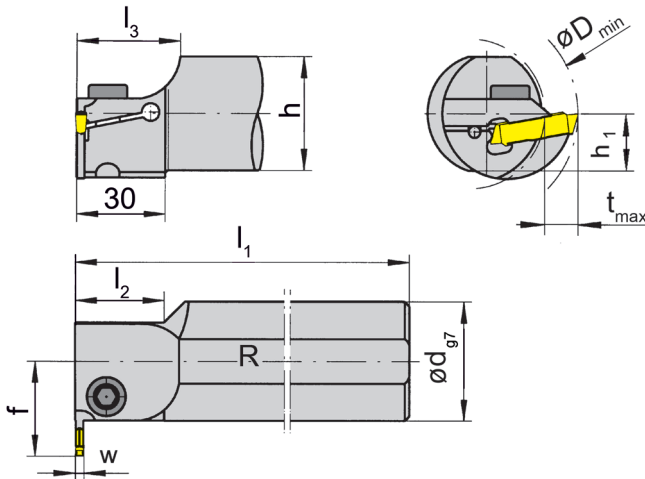

R = right hand version shown

L = left hand version

Part number	d	l ₁	l ₂	l ₃	h	h ₁	f	t _{max}	D _{min}	Size	Clamping range
R/L213.0025.03	25	150	-	31.8	23	11.5	24.5	7.5	38	03	3.0 - 4.0
R/L213.0032.03	32	150	30	35.0	30	15.0	28.0	7.5	38	03	3.0 - 4.0
R/L213.0040.03	40	180	30	37.4	38	19.0	32.0	11.5	50	03	3.0 - 4.0
R/L213.0050.03	50	200	30	39.1	47	23.5	40.5	15.0	60	03	3.0 - 4.0
R/L213.0025.04	25	150	-	31.8	23	11.5	24.5	7.5	38	04	4.0 - 5.0
R/L213.0032.04	32	150	30	35.0	30	15.0	28.0	7.5	38	04	4.0 - 5.0
R/L213.0040.04	40	180	30	37.4	38	19.0	32.0	11.5	50	04	4.0 - 5.0
R/L213.0050.04	50	200	30	39.1	47	23.5	40.5	15.0	60	04	4.0 - 5.0
R/L213.0032.05	32	150	-	35.0	30	15.0	28.0	11.5	46	05	5.1 - 6.0
R/L213.0040.05	40	180	30	35.0	38	19.0	32.0	11.5	50	05	5.1 - 6.0
R/L213.0050.05	50	200	30	40.0	47	23.5	40.5	15.0	60	05	5.1 - 6.0
R/L213.0040.07	40	180	30	35.0	38	19.0	32.0	11.5	50	07	6.1 - 8.0
R/L213.0050.07	50	200	30	40.0	47	23.5	40.5	15.0	60	07	6.1 - 8.0

State R or L version

w see indexable inserts

Dimensions in mm

Further sizes upon request

Note toolholder with shank- \varnothing 25 or 32 mm

The full depth of cut $t_{max} = 11.5$ mm will be reached from D_{min} 46 mm

For torque specification of the screw, please see Technical Instructions.

Spare Parts

Toolholder	Clamping Screw	Allen wrench
R/L213...	218.3	SW6,0 DIN911



Grooving and Side Turning (internal)



Toolholder

U213

Short style

Bore Ø from
Depth of groove up to
Clamping range

1.969"
.591"
.319 - .413"

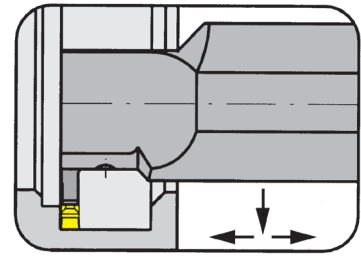

for Indexable insert

Type 229
S229
N229

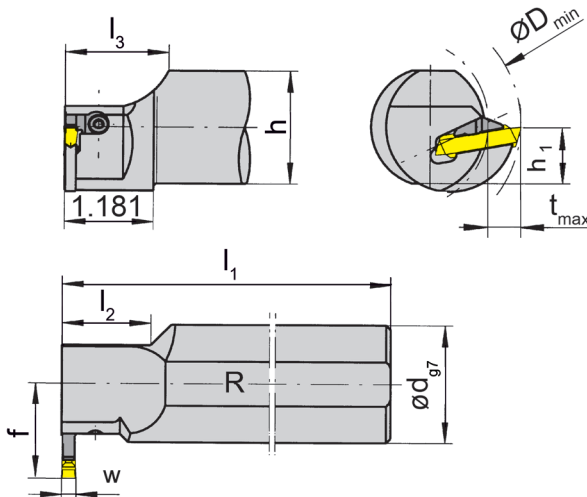

R = right hand version shown

L = left hand version

Part number	d	l ₁	l ₂	l ₃	h	h ₁	f	t _{max}	D _{min}	Size	Clamping range
R/LU213.1500.09	1.500	7.008	1.260	1.375	1.421	.711	1.220	.453	1.969	09	.319 - .409
R/LU213.2000.09	2.000	7.992	1.260	1.500	1.921	.961	1.614	.591	2.362	09	.319 - .413

State R or L version

w see indexable inserts

Dimensions in inch

Further sizes upon request

Note:

Please note type of clamp.

For torque specification of the screw, please see Technical Instructions.

Spare Parts

Toolholder	Clamping element	TORX PLUS® Wrench
LU213...	L218.9	T15PQ
RU213...	R218.9	T15PQ

H42

Call Us Toll Free (888) 818-4676

H

Grooving and Side Turning (internal)



Toolholder

213

Short style

Bore Ø from
Depth of groove up to
Clamping range

50 mm
15 mm
8.1 - 10.4 mm

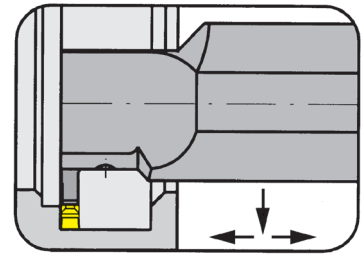

for Indexable insert

Type 229
S229
N229

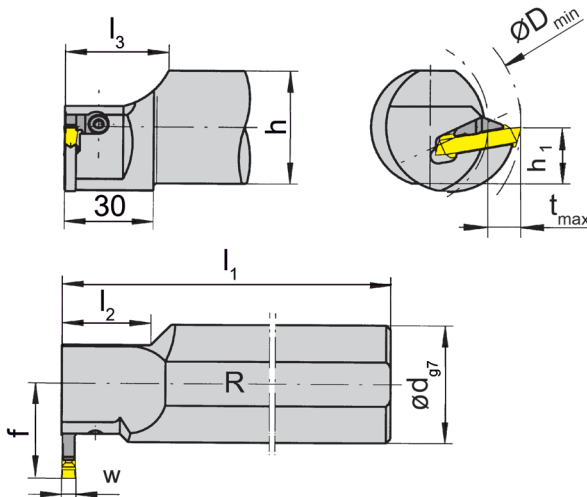

R = right hand version shown

L = left hand version

Part number	d	l ₁	l ₂	l ₃	h	h ₁	f	t _{max}	D _{min}	Size	Clamping range
R/L213.0040.09	40	180	30	35	38	19.0	32.0	11.5	50	09	8.1 - 10.4
R/L213.0050.09	50	200	30	40	47	23.5	40.5	15.0	60	09	8.1 - 10.4

State R or L version

w see indexable inserts

Dimensions in mm

Further sizes upon request

Note:

Please note type of clamp.

For torque specification of the screw, please see Technical Instructions.

Spare Parts

Toolholder	Clamping element	TORX PLUS® Wrench
L213.0...	R218.9	T15PQ
R213.0...	L218.9	T15PQ



Grooving and Side Turning (internal)



Toolholder

U213

Short style

Bore \varnothing from
Depth of groove up to
Clamping range

1.496"
.453"
.118 - .200"

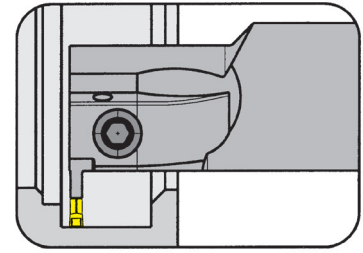

for Indexable insert

Type 229
S229
N229

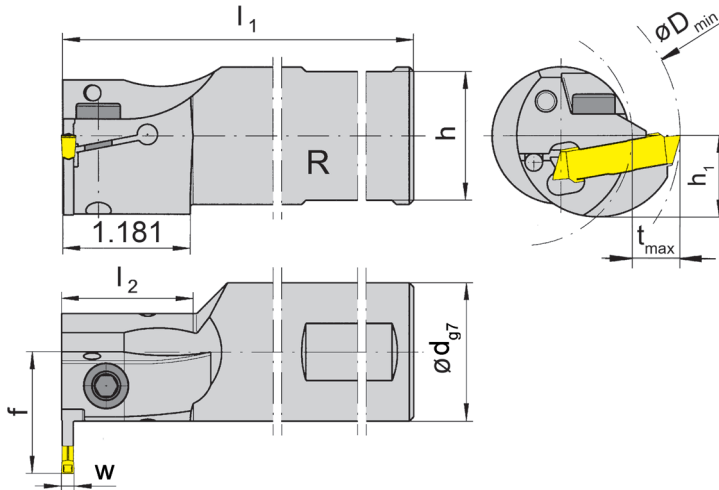

R = right hand version shown

L = left hand version

with through coolant supply

Part number	d	l ₁	l ₂	h	h ₁	f	t _{max}	D _{min}	Size	Clamping range
R/LU213.1500.03IK	1.500	7.008	1.260	1.421	.711	1.220	.453	1.969	03	.118 - .157
RU213.1250.03IK	1.250	6.004	1.260	1.171	.586	1.102	.453	1.496	03	.118 - .157
R/LU213.1500.04IK	1.500	7.008	1.260	1.421	.711	1.220	.453	1.969	04	.157 - .200
RU213.1250.04IK	1.250	6.004	1.260	1.171	.586	1.102	.453	1.496	04	.157 - .200

State R or L version

w see indexable inserts

Dimensions in inch

Note Toolholders with shank \varnothing 1.250":

The full depth of cut $t_{max} = .453"$ will be reached from $D_{min} 1.811"$

Further sizes upon request

For torque specification of the screw, please see Technical Instructions.

Spare Parts

Toolholder	Allen wrench
R/LU213...	SW5,0 DIN911

H44

Call Us Toll Free (888) 818-4676

H

Grooving and Side Turning (internal)



Toolholder

213

Short style

Bore \varnothing from
Depth of groove up to
Clamping range

38 mm
11.5 mm
3 - 5 mm

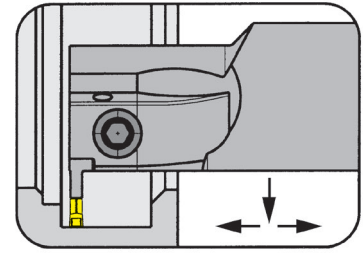

for Indexable insert

Type 229
S229
N229

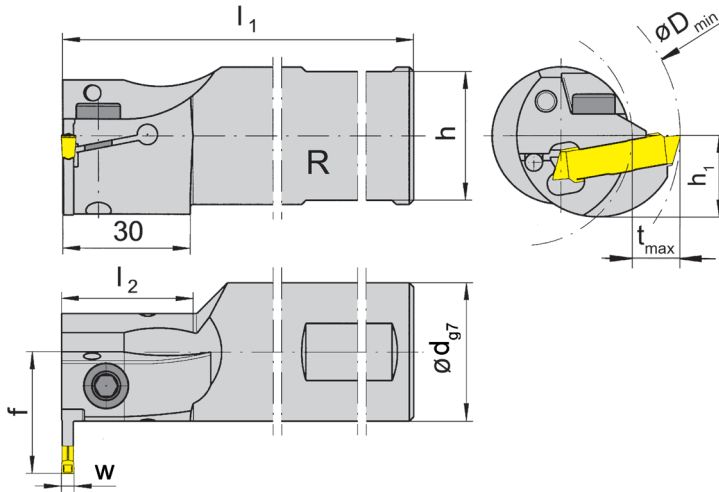

R = right hand version shown

L = left hand version

with through coolant supply

Part number	d	l ₁	l ₂	h	h ₁	f	t _{max}	D _{min}	Size	Clamping range
R/L213.0025.03IK	25	150	-	23	11.5	24.5	7.5	38	03	3 - 4
R/L213.0032.03IK	32	150	30	30	15.0	28.0	7.5	38	03	3 - 4
R/L213.0040.03IK	40	180	30	38	19.0	32.0	11.5	50	03	3 - 4
R/L213.0025.04IK	25	150	-	23	11.5	24.5	7.5	38	04	4 - 5
R/L213.0032.04IK	32	150	30	30	15.0	28.0	7.5	38	04	4 - 5
R/L213.0040.04IK	40	180	30	38	19.0	32.0	11.5	50	04	4 - 5

State R or L version

w see indexable inserts

Dimensions in mm

Note toolholder with shank- \varnothing 25 or 32 mm

The full depth of cut $t_{max} = 11.5$ mm will be reached from D_{min} 46 mm

Further sizes upon request

For torque specification of the screw, please see Technical Instructions.

Spare Parts

Toolholder	Allen wrench	Screw
R/L213...	SW5,0 DIN911	6.14.912

Grooving and Side Turning (internal)



Toolholder

213

Short style

Bore \varnothing from
Depth of groove up to
Clamping range

46 mm
11.5 mm
3 - 6 mm

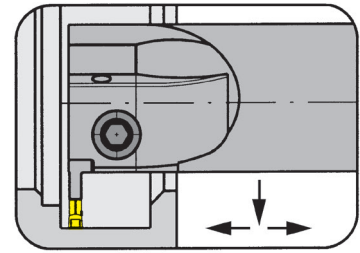

for Indexable insert

Type 229
S229
N229

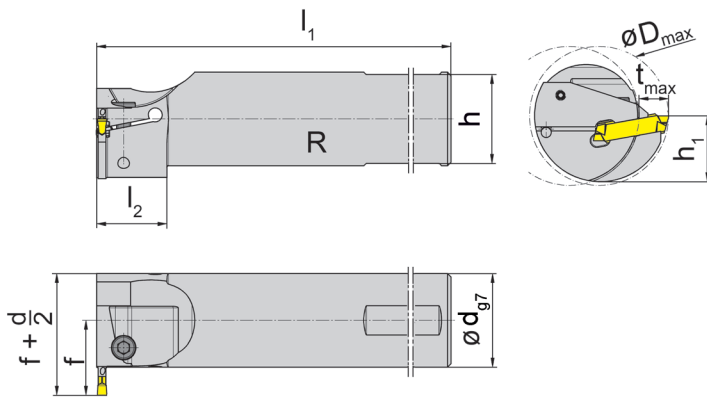

with through coolant supply

R = right hand version shown

L = left hand version

Part number	d	l ₁	l ₂	h	h ₁	f	t _{max}	D _{min}	Size	Clamping range
R/L213.0032.0.03IK	32	150	30	30	15	28	11.5	46	03	3.0 - 4.0
R/L213.0032.0.04IK	32	150	30	30	15	28	11.5	46	04	4.0 - 5.0
R/L213.0040.0.04IK	40	180	30	38	19	32	11.5	54	04	4.0 - 5.0
R/L213.0040.0.05IK	40	180	30	38	19	32	11.5	54	05	5.1 - 6.0

State R or L version

w see indexable inserts

Dimensions in mm

Further sizes upon request

For torque specification of the screw, please see Technical Instructions.

Spare Parts

Toolholder	Allen wrench	Screw
R/L213...	SW5,0 DIN911	6.14.912

H46

Call Us Toll Free (888) 818-4676

H

Grooving and Side Turning (internal)



Toolholder

U214

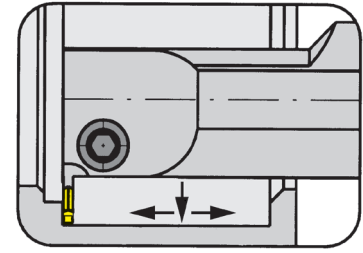

Bore Ø from 1.496"
 Depth of groove up to .591"
 Clamping range .118 - .319"

for Indexable insert

Type 229
 S229
 N229

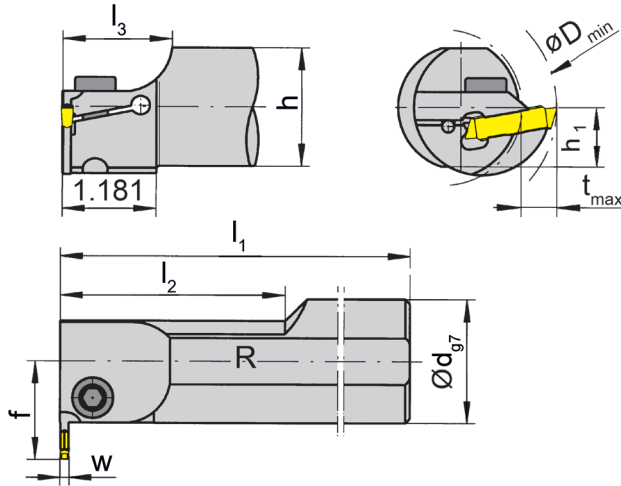

R = right hand version shown

L = left hand version

Part number	d	l ₁	l ₂	l ₃	h	h ₁	f	t _{max}	D _{min}	Size	Clamping range
R/LU214.1250.03	1.250	7.992	2.756	1.375	1.171	.586	1.102	.453	1.496	03	.118 - .157
R/LU214.1500.03	1.500	10.000	3.268	1.375	1.421	.711	1.220	.453	1.969	03	.118 - .157
R/LU214.2000.03	2.000	10.000	4.016	1.500	1.882	.941	1.614	.591	2.362	03	.118 - .157
R/LU214.1250.04	1.250	7.992	2.756	1.375	1.171	.586	1.102	.453	1.496	04	.157 - .200
R/LU214.1500.04	1.500	10.000	3.268	1.375	1.421	.711	1.220	.453	1.969	04	.157 - .200
R/LU214.2000.04	2.000	10.000	4.016	1.500	1.882	.941	1.614	.591	2.362	04	.157 - .200
R/LU214.1250.05	1.250	7.992	-	1.375	1.171	.586	1.102	.453	1.811	05	.201 - .240
R/LU214.1500.05	1.500	10.000	3.268	1.375	1.421	.711	1.220	.453	1.969	05	.201 - .240
R/LU214.2000.05	2.000	10.000	4.016	1.500	1.882	.941	1.614	.591	2.362	05	.201 - .240
R/LU214.1500.07	1.500	10.000	3.268	1.375	1.421	.711	1.220	.453	1.969	07	.240 - .319
R/LU214.2000.07	2.000	10.000	4.016	1.500	1.882	.941	1.614	.591	2.362	07	.240 - .319

State R or L version

w see indexable inserts

Dimensions in inch

Note Toolholders with shank Ø 1.250":

The full depth of cut t_{max} = .453" will be reached from D_{min} 1.811"

Further shank sizes or with through coolant supply upon request.

For torque specification of the screw, please see Technical Instructions.

Spare Parts

Toolholder	Clamping Screw	Allen wrench
R/LU214...	218.3	SW6,0 DIN911



Toolholder

214

Bore \varnothing from
Depth of groove up to
Clamping range

38 mm
15 mm
3 - 8 mm

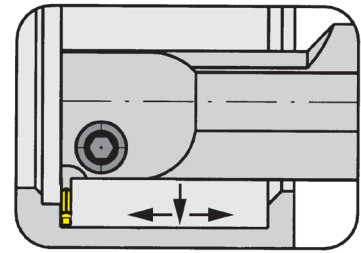

for Indexable insert

Type 229
S229
N229

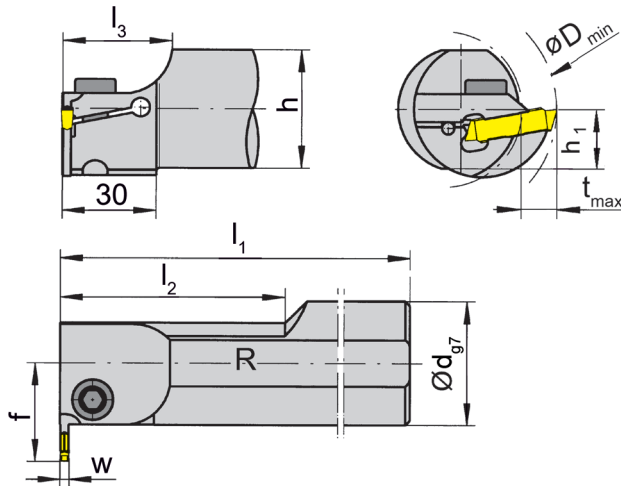

R = right hand version shown

L = left hand version

Part number	d	l ₁	l ₂	l ₃	h	h ₁	f	t _{max}	D _{min}	Size	Clamping range
R/L214.0032.03	32	200	70	35	30	15.0	28.0	7.5	38	03	3.0 - 4.0
R/L214.0040.03	40	250	80	35	38	19.0	32.0	11.5	50	03	3.0 - 4.0
R/L214.0050.03	50	250	100	40	47	23.5	40.5	15.0	60	03	3.0 - 4.0
R/L214.0032.04	32	200	70	35	30	15.0	28.0	7.5	38	04	4.0 - 5.0
R/L214.0040.04	40	250	80	35	38	19.0	32.0	11.5	50	04	4.0 - 5.0
R/L214.0050.04	50	250	100	40	47	23.5	40.5	15.0	60	04	4.0 - 5.0
R/L214.0032.05	32	200	-	35	30	15.0	28.0	11.5	46	05	5.1 - 6.0
R/L214.0040.05	40	250	80	35	38	19.0	32.0	11.5	50	05	5.1 - 6.0
R/L214.0050.05	50	250	100	40	47	23.5	40.5	15.0	60	05	5.1 - 6.0
R/L214.0040.07	40	250	80	35	38	19.0	32.0	11.5	50	07	6.1 - 8.0
R/L214.0050.07	50	250	100	40	47	23.5	40.5	15.0	60	07	6.1 - 8.0

State R or L version

w see indexable inserts

Dimensions in mm

Note toolholder with shank- \varnothing 25 or 32 mm

The full depth of cut $t_{max} = 11.5$ mm will be reached from D_{min} 46 mm

Further shank sizes or with through coolant supply upon request.

For torque specification of the screw, please see Technical Instructions.

Spare Parts

Toolholder	Clamping Screw	Allen wrench
R/L214...	218.3	SW6,0 DIN911

Grooving and Side Turning (internal)



Toolholder

U214

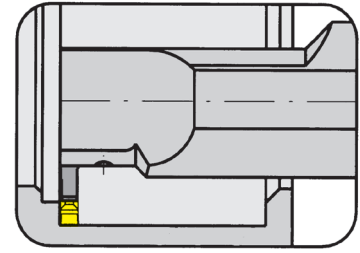

Bore \varnothing from
Depth of groove up to
Clamping range

1.969"
.591"
.319 - .409"

for Indexable insert

Type 229
S229
N229

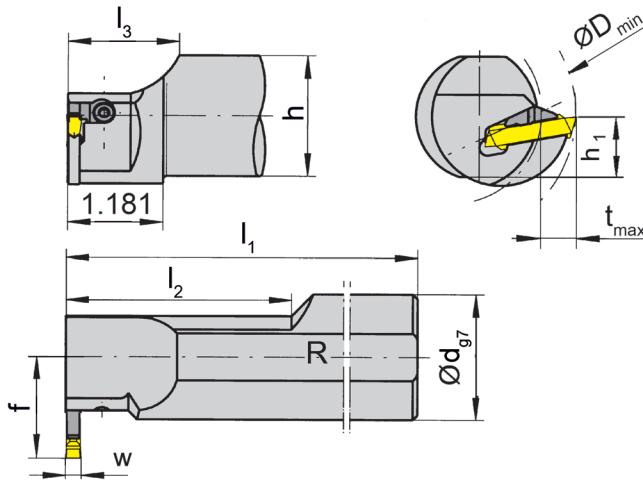

R = right hand version shown

L = left hand version

Part number	d	l ₁	l ₂	l ₃	h	h ₁	f	t _{max}	D _{min}	Size	Clamping range
R/LU214.1500.09	1.500	10	3.307	1.375	1.421	.711	1.220	.453	1.969	09	.319 - .409
R/LU214.2000.09	2.000	10	4.016	1.500	1.882	.941	1.614	.591	2.362	09	.319 - .394

State R or L version

w see indexable inserts

Dimensions in inch

Further shank sizes or with through coolant supply upon request.

Note:

Please note type of clamp.

For torque specification of the screw, please see Technical Instructions.

Spare Parts

Toolholder	Clamping element	TORX PLUS® Wrench
LU214...	L218.9	T15PQ
RU214...	R218.9	T15PQ



Grooving and Side Turning (internal)



Toolholder

214

Bore Ø from 50 mm
 Depth of groove up to 15 mm
 Clamping range 8.1 - 10.4 mm

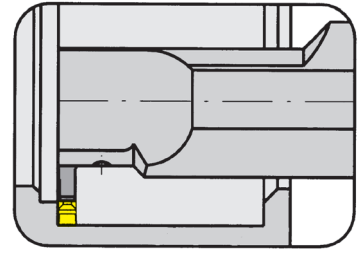

for Indexable insert

Type 229
 S229
 N229

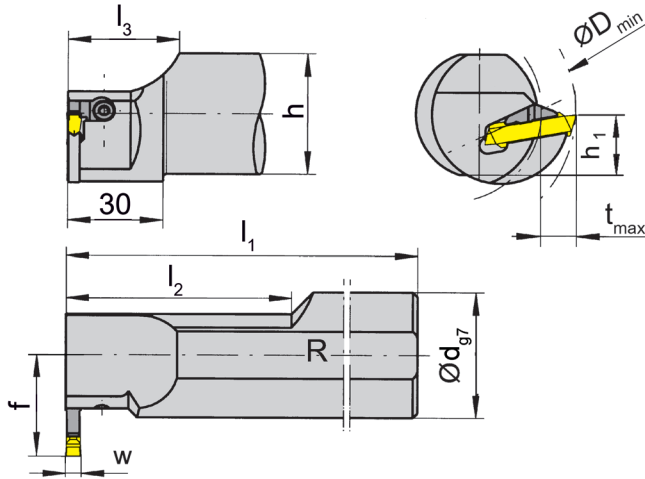

R = right hand version shown

L = left hand version

Part number	d	l ₁	l ₂	l ₃	h	h ₁	f	t _{max}	D _{min}	Size	Clamping range
R/L214.0040.09	40	250	80	35	38	19.0	32.0	11.5	50	09	8.1 - 10.4
R/L214.0050.09	50	250	100	40	47	23.5	40.5	15.0	60	09	8.1 - 10.4

State R or L version

w see indexable inserts

Dimensions in mm

Further shank sizes or with through coolant supply upon request.

Note:

Please note type of clamp.

For torque specification of the screw, please see Technical Instructions.

Spare Parts

Toolholder	Clamping element	TORX PLUS® Wrench
L214.0...	R218.9	T15PQ
R214.0...	L218.9	T15PQ

H50

Call Us Toll Free (888) 818-4676

Grooving and Side Turning (internal)



Basic toolholder

BU229

without cassette

Bore Ø
Depth of groove up to
Width of groove

1.969"
.591"
.236"

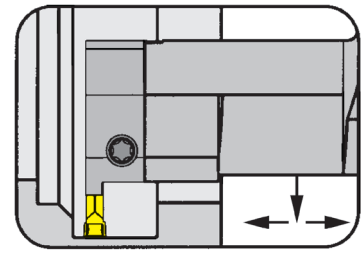

for Cassette

Type BK229

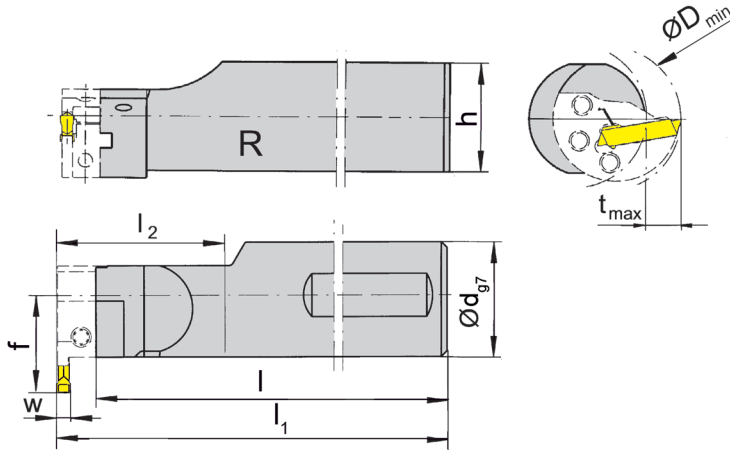

R = right hand version shown

L = left hand version

with through coolant supply

Part number	d	l	l ₁	l ₂	h	f
R/LBU229.1500.1.K2	1.500	6.929	7.500	1.250	1.421	1.398
LBU229.1500.2.K2	1.500	7.469	8.000	2.250	1.421	1.398
RBU229.1500.2K2	1.500	7.469	8.000	2.250	1.421	1.398

State R or L version

Dimensions in inch

Further sizes upon request

Note:

Dimensions for D_{min}, t_{max} see cassettes

Spare Parts

Basic toolholder	Clamping Screw	TORX PLUS® Wrench
R/LBU229...	030.0518.T20P	T20PQ

Basic toolholder

B229

without cassette

Bore \varnothing
Depth of groove up to
Width of groove

50 / 60 mm
12 / 15 mm
3 - 6 mm

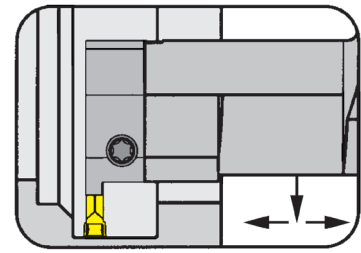

for Cassette

Type BK229

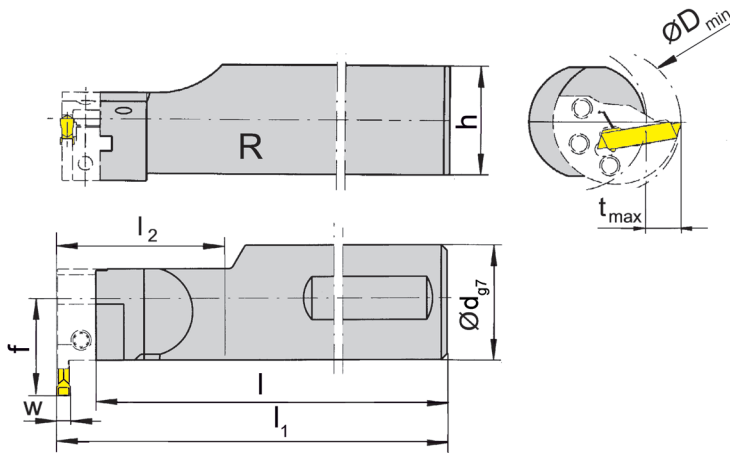

R = right hand version shown

L = left hand version

with through coolant supply

Part number	d	l	l ₁	l ₂	h	f
R/LB229.0040.1.K2	40	172.5	187	30	38	35.5
R/LB229.0040.2.K2	40	185.5	200	60	38	35.5

State R or L version

w see indexable inserts

Dimensions in mm

Further sizes upon request

Note:

Dimensions for D_{min} , t_{max} see cassettes

Spare Parts

Basic toolholder	Clamping Screw	TORX PLUS® Wrench
R/LB229...	030.0518.T20P	T20PQ

Grooving and Side Turning (internal)



Basic toolholder

B229

without cassette

Bore \varnothing from
Depth of groove up to
Clamping range

50 / 60 mm
12 / 15 mm
3 - 6 mm

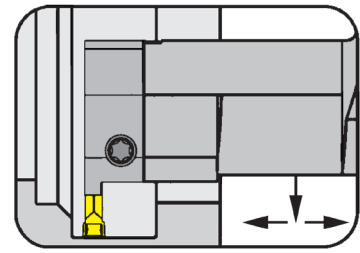

for Cassette

Type BK229...IK

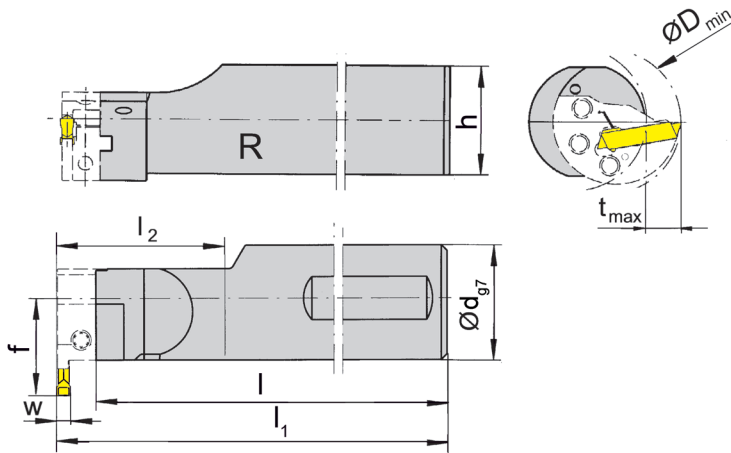

R = right hand version shown

L = left hand version

with through coolant supply

Part number	d	l	l_1	l_2	h	f
R/LB229.0040.1.K2.IK	40	172.5	187	30	38	35.5
R/LB229.0040.2.K2.IK	40	185.5	200	60	38	35.5

State R or L version

w see indexable inserts

Dimensions in mm

Further sizes upon request

Note:

Dimensions for D_{min} , t_{max} and b_1 see cassettes

Spare Parts

Basic toolholder	Clamping Screw	TORX PLUS® Wrench
R/LB229...IK	030.0518.T20P	T20PQ



Cassette

BK229

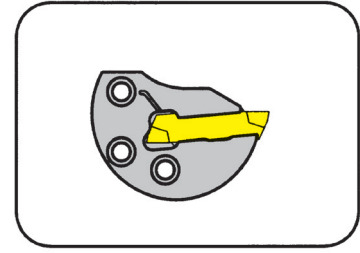

Bore \varnothing from	50 / 60 mm
Depth of groove	12 / 15 mm
Clamping range	3 - 6 mm

for Indexable insert

Type 229
S229
N229

Depth of groove in relation to bore \varnothing

D_{min}	t_{max}
50	12
60	15

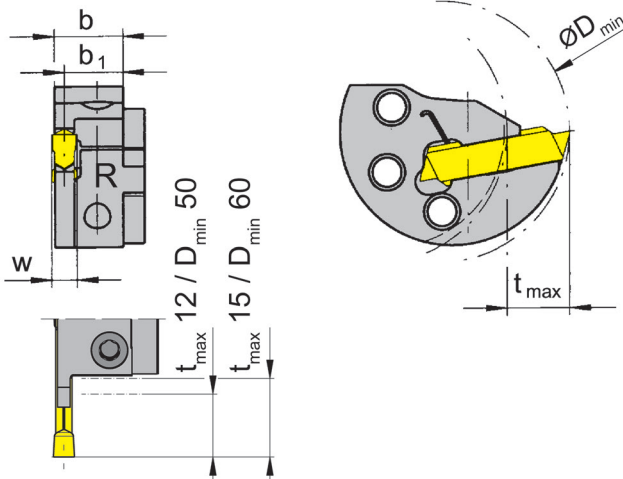

R = right hand version shown

L = left hand version

Part number	b	b ₁	Size	Clamping range
R/LBK229.0050.03	14.25	13.0	03	3.00 - 4.00
R/LBK229.0050.04	14.20	12.5	04	4.00 - 5.09
R/LBK229.0050.05	13.85	11.5	05	5.10 - 6.00

State R or L version

w see indexable inserts

Dimensions in mm

Further sizes upon request

Use right hand cassettes in right hand basic toolholders and left hand cassettes in left hand basic toolholders.

Ordering note:

The fastening screw is combined with the basic toolholder - no separate order required.

Spare Parts

Cassette	Clamping Screw	TORX PLUS® Wrench
R/LBK229...	5.13T20EP	T20PQ

Cassette

BK229

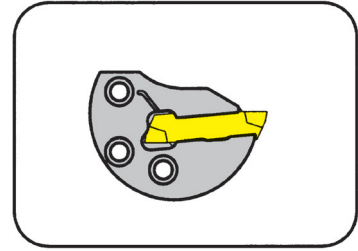

Bore \varnothing from
Depth of groove
Clamping range

50 / 60 mm
12 / 15 mm
3 - 6 mm

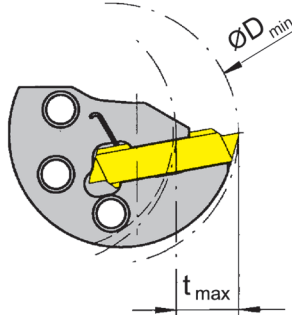
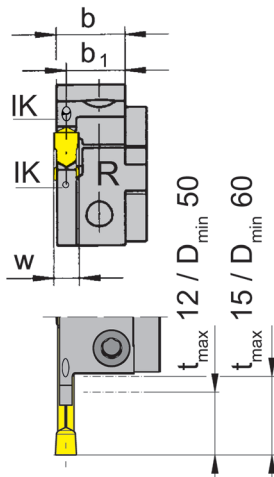

for Indexable insert

Type 229
S229
N229

Depth of groove in relation to bore \varnothing

D_{min}	t_{max}
50	12
60	15

with through coolant supply

R = right hand version shown

L = left hand version

Part number	b	b_1	Size	Clamping range
R/LBK229.0050.03.IK	14.20	13.0	03	3.00 - 4.00
R/LBK229.0050.04.IK	14.15	12.5	04	4.00 - 5.09
R/LBK229.0050.05.IK	13.80	11.5	05	5.10 - 6.00

State R or L version

w see indexable inserts

Dimensions in mm

Further sizes upon request

Use right hand cassettes in right hand basic toolholders and left hand cassettes in left hand basic toolholders.

Ordering note:

The fastening screw is combined with the basic toolholder - no separate order required.

Spare Parts

Cassette	Clamping Screw	TORX PLUS® Wrench
R/LBK229...	5.13T20EP	T20PQ

Cartridge

257

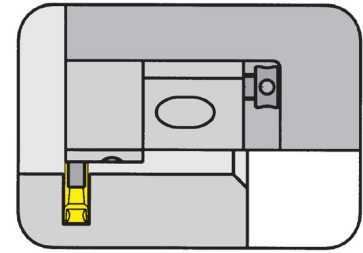

Bore \varnothing from 80 / 120 mm
 Depth of groove 10 / 15 mm
 Clamping range 5.1 - 10.4 mm

for Indexable insert

Type 229
 S229
 N229

Depth of groove in relation to bore \varnothing

D_{min}	t_{max}
80	10
120	15

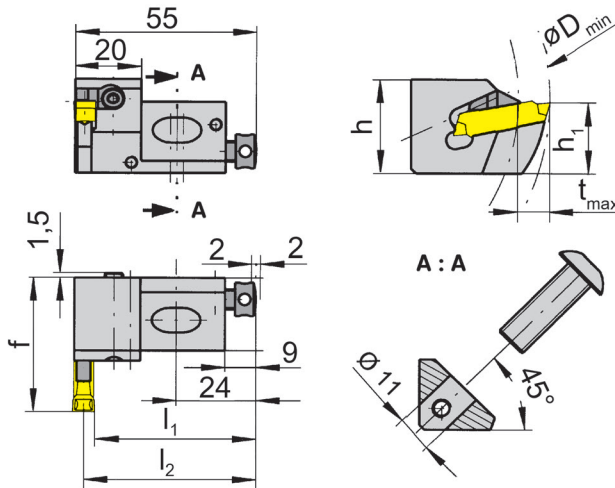

R = right hand version shown

L = left hand version

Part number	h	h ₁	f	l ₂	l ₁	Size	Clamping range
R/L257.2222.05	29	22	42	52.2	l ₂ -w/2	05	5.1 - 6.0
R/L257.2222.07	29	22	42	51.2	l ₂ -w/2	07	6.1 - 8.0
R/L257.2222.09	29	22	42	50.2	l ₂ -w/2	09	8.1 - 10.4

State R or L version

w see indexable inserts

Dimensions in mm

Further sizes upon request

Ordering note:

Please note type of clamp.

For torque specification of the screw, please see Technical Instructions.

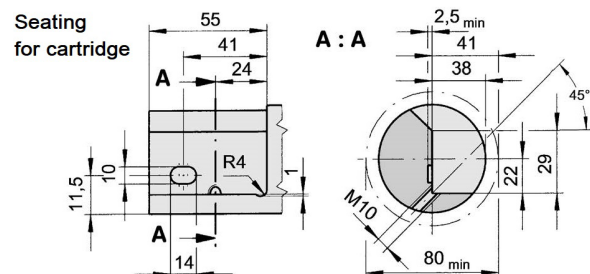

Spare Parts

Cartridge	Clamping Screw	Allen wrench	Screw	Clamping element	TORX PLUS® Wrench
R/L257.2222.05	218.3	SW2,0 DIN911	6.12.020		
L257.2222.07	4.08.913		6.12.020	R218.5.7.32	T15PQ
L257.2222.09	4.08.913		6.12.020	R218.9.32	T15PQ
R257.2222.07	4.08.913		6.12.020	L218.5.7.32	T15PQ
R257.2222.09	4.08.913		6.12.020	L218.9.32	T15PQ

Cassette

050

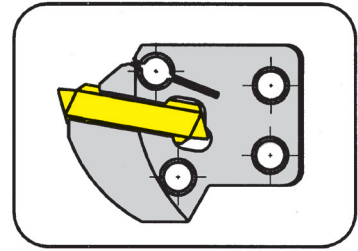

Bore \varnothing from
Depth of groove up to
Width of groove

62 mm
14 mm
3 - 5 mm

for basic toolholder type 210 with cassette

for Indexable insert

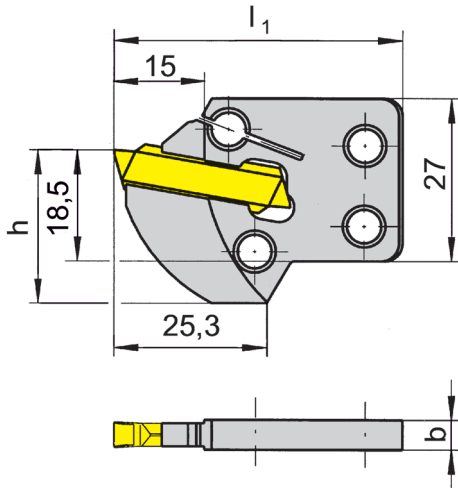

Type 229
S229
N229

Depth of groove in relation to bore \varnothing

D _{min}	t _{max}
62	10
65	11
70	13
≥ 80	14

Part number	b	l ₁	h	Size	Clamping range
050.1827.0071	4.9	47	25.5	03	3.00 - 4.00
050.1827.0009	4.9	47	25.5	04	4.00 - 5.09

Further sizes upon request

Dimensions in mm

For torque specification of the screw, please see Technical Instructions.

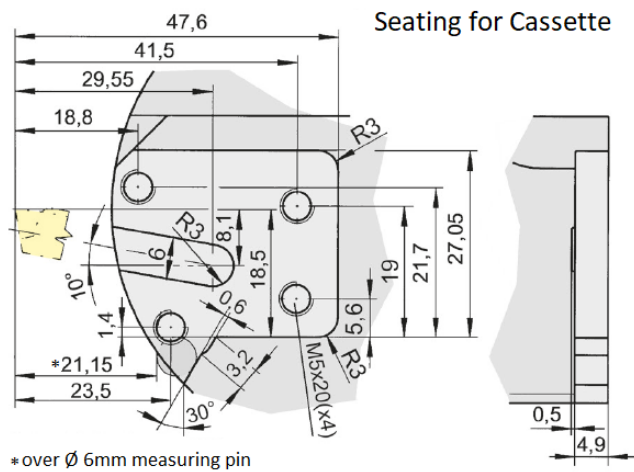

Cassette	Fixing Screw	TORX PLUS® Wrench
050.1827.00....	030.0518T20P	T20PQ



Indexable insert

S229...3.

Precision Sintered



Geometry .3.

Geometry with chip forming for all materials.

Characteristics

- Excellent swarf control
- Suitable for high alloy- high strength steels
- Reduced swarf width gives high flank surface finish
- Excellent swarf control allows production security

Applications

- Grooving:
Depth of groove up to 25 mm
- Side turning:
Depth of cut a_p up to 4 mm*

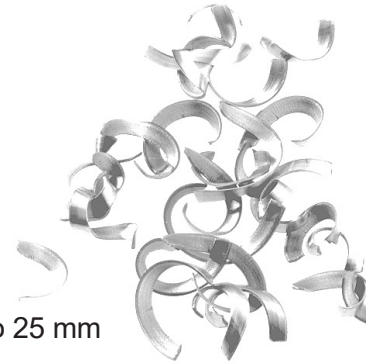

Feed Rate f

- Grooving: 0.15 up to 0.25 mm/rev*
- Side turning: up to 0.4 mm/rev*

* dependent upon width of insert

Indexable inserts with profiles, intermediate sizes or other edge radii are available upon request. Indexable inserts can be used in **right and left hand** toolholders.

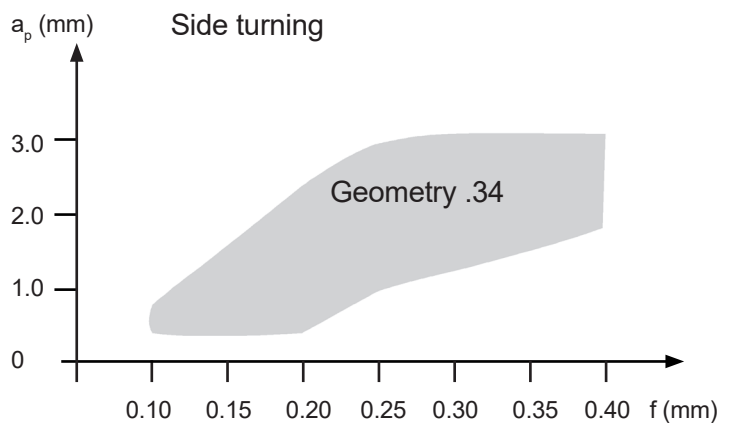

Chip control graph S229.0500.34 material 16MnCr5

Grooving and Side Turning



Indexable insert

S229

with chip former

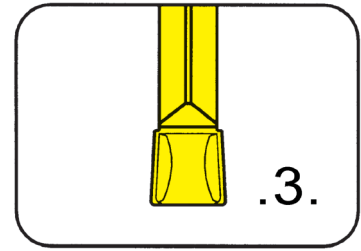

Depth of groove up to
Width of groove

.984"
.118 - .394"

precision sintered

for Toolholder

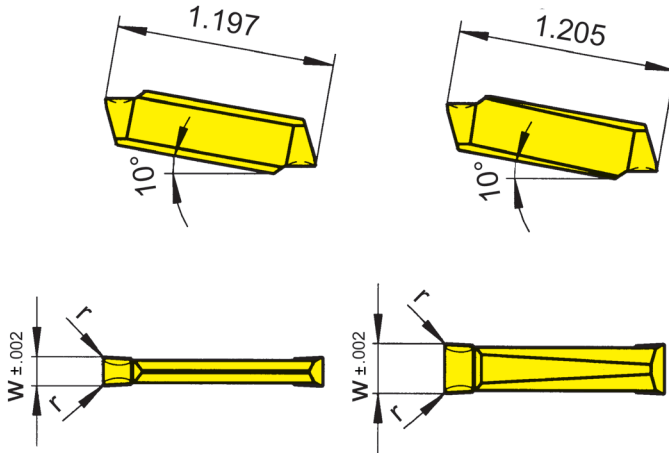

- Type
- 210/U210
 - 218/U218
 - 226/U226
 - 219/U219
 - 213/U213
 - 214/U214
 - R/LA210
 - R/LAU210
 - R/LA226
 - R/LAU226
 - 257

Indexability length $\pm .002''$

Width = .118 - .197"

Width = .236 - .394"

Part number	w	r	Size	Carbide grades																
				MG12	P20	AL96	AS62	AS66	H54	TA45	TC92	TF42	TF45	TI22	TI25	TN32	TN35	IG66		
S229.0300.32	.118	.008	03	▲	x	▲	▲	▲	▲	▲	x	Δ		▲	▲	▲	▲	▲	▲	
S229.0300.34	.118	.016	03	x	x	▲	▲	▲	▲	▲		Δ		▲	▲	▲	▲	▲	▲	
S229.0400.32	.157	.008	03/04	x	x	▲	▲	▲	▲	▲	x	Δ		▲	x	▲	▲	▲	▲	
S229.0400.34	.157	.016	03/04	x	x	▲	▲	▲	▲	▲		Δ	▲	▲	x	▲	▲	▲	▲	
S229.0500.34	.197	.016	04	x	x	▲	▲	▲	x	x	x	Δ		▲	▲	▲	▲	▲	▲	
S229.0500.36	.197	.024	04		x							x			x	x	x	x	▲	
S229.0600.34	.236	.016	05	x	x	▲	▲	▲	x	x	x	Δ		▲	▲	▲	▲	▲	▲	
S229.0600.38	.236	.031	05			▲	▲	▲				Δ			x				▲	
S229.0700.36	.276	.024	07	x	x	x	▲					Δ				▲	x	▲	▲	
S229.0800.36	.315	.024	07/08	x	x		▲					Δ			▲	▲	▲	▲	▲	
S229.0800.38	.315	.031	07/08									x			▲	x	x	x	▲	
S229.0800.3K	.315	.047	07/08									x			x				▲	
S229.1000.36	.394	.024	09	x	x		▲					Δ			▲	▲	▲	▲	▲	
				P	○	●	●	●	●	●	●	●	●	●	●	●	●	●	●	●
				M	-	-	-	-	○	●	●	-	-	●	-	●	-	●	●	
				K	-	-	●	-	●	-	●	-	-	●	-	●	-	●	-	
				N	-	-	●	-	●	-	●	-	-	●	-	●	-	●	-	
				S	-	-	-	-	○	-	●	-	-	●	-	●	-	●	○	
				H	-	-	-	-	-	-	-	-	-	-	-	-	-	-	-	

Dimensions in inch

Carbide grades

Indexable inserts can be used in right and left hand toolholders.

Indexable Insert

S229...5.

Precision Sintered



Geometry .5.

Easy cutting geometry for materials with medium strength.

Characteristics

- Excellent swarf on a wide feed range
- Easy cutting - low power requirement
- Reduced swarf width gives high flank surface finish
- Excellent swarf control allows production security

Applications

- Grooving: Depth of groove up to 25 mm
- Side turning: Depth of cut a_p up to 4 mm*

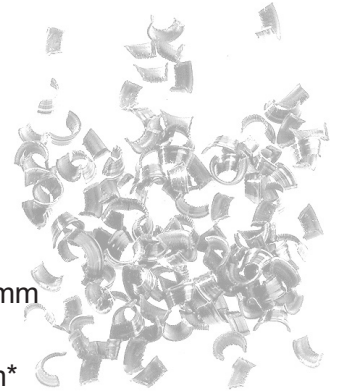

Feed Rate f

- Grooving: up to 0.45 mm/rev*
- Side turning: up to 0.6 mm/rev*

* dependent upon width of insert

Indexable inserts with profiles, intermediate sizes or other edge radii are available upon request. Indexable inserts can be used in **right and left hand** toolholders.

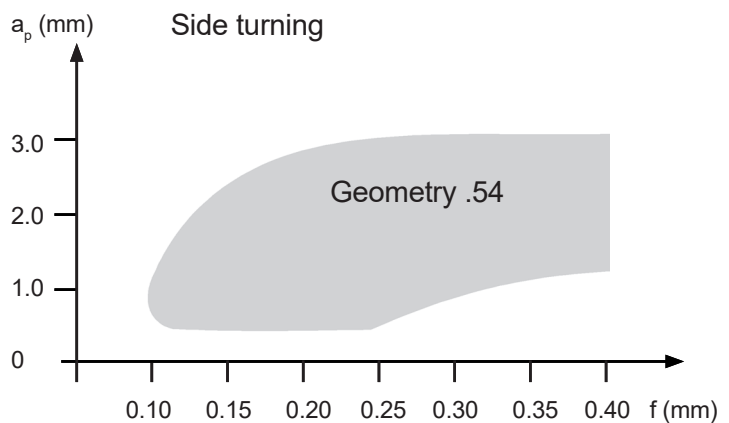

Chip control graph S229.0500.54 material 16MnCr5

Grooving and Side Turning



Indexable insert

S229

with chip forming

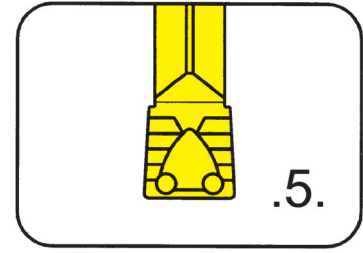

Depth of groove up to
Width of groove

.984"
.118 - .394"

precision sintered

for Toolholder

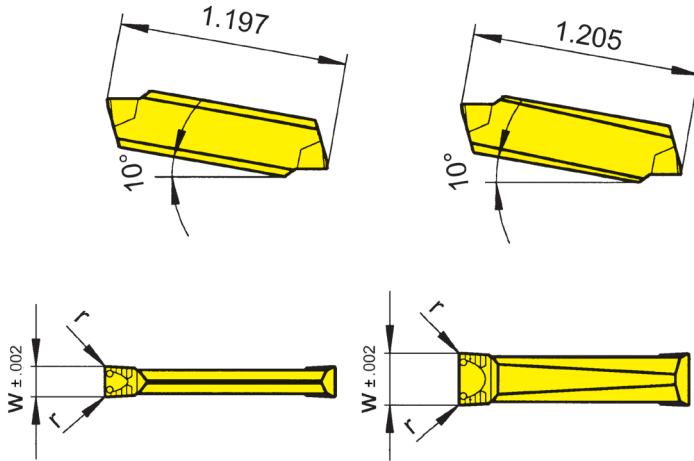

- Type
- 210/U210
 - 218/U218
 - 226/U226
 - 219/U219
 - 213/U213
 - 214/U214
 - R/LA210
 - R/LAU210
 - R/LA226
 - R/LAU226
 - 257

Indexability length $\pm .002''$

Width = .118 - .197"

Width = .236 - .394"

Part number	w	r	Size	P20	AL96	AS62	AS65	TC92	TF42	TF45	TI22	TI25	TN32	TN35	IG66
S229.0300.52	.118	.008	03	x	x	▲		△		▲	▲	▲	▲	▲	▲
S229.0300.54	.118	.016	03		x	▲		△		x	▲	▲	▲		▲
S229.0400.52	.157	.008	03/04	x	x	▲		△		▲	▲	▲	▲	▲	▲
S229.0400.54	.157	.016	03/04		x	▲				▲	▲	▲	▲	▲	▲
S229.0500.54	.197	.016	04	x	x	▲		△		▲	▲	▲	▲	▲	▲
S229.0600.54	.236	.016	05	x	▲	▲		△		▲		▲	▲	▲	▲
S229.0600.56	.236	.024	05		x			x				x	x	x	▲
S229.0600.58	.236	.031	05			▲	x								▲
S229.0500.56	.197	.024	06					x				x	x	x	▲
S229.0700.56	.276	.024	07	x		▲		△			▲		x		△
S229.0800.56	.315	.024	07/08	x	▲	▲		△			▲		▲		
S229.0800.58	.315	.031	07/08	x	x			△	▲		▲		x		
S229.0800.5K	.315	.047	07/08		x			x			▲				
S229.1000.56	.394	.024	09	x	x			x			▲		▲		
P	●	●	●	●	●	●	●	●	●	●	●	●	●	●	●
M	-	-	-	○	-	-	-	-	-	●	-	●	-	-	●
K	-	●	-	○	-	-	-	-	-	●	-	●	-	●	-
N	-	●	-	-	-	-	-	-	-	●	-	●	-	-	-
S	-	-	-	-	-	-	-	-	-	●	-	●	-	●	○
H	-	-	-	-	-	-	-	-	-	-	-	-	-	-	-

Dimensions in inch

Carbide grades

Indexable inserts can be used in right and left hand toolholders.

Indexable Insert

S229...A.

Precision Sintered



Geometry .A.

Geometry with excellent chip breaking for materials with medium strength

Characteristics

- Excellent swarf on a wide feed range
- Excellent swarf control, also by partial cutting
- Reduced swarf width gives high flank surface finish
- Excellent swarf control allows production security

Applications

- Grooving:
Depth of groove up to 18 mm
- Side turning:
Depth of cut a_p up to 2.5 mm*

Feed Rate f

- Grooving: up to 0.3 mm/rev*
- Side turning: up to 0.3 mm/rev*

* dependent upon width of insert

Indexable inserts with profiles, intermediate sizes or other edge radii are available upon request. Indexable inserts can be used in **right and left hand** toolholders.

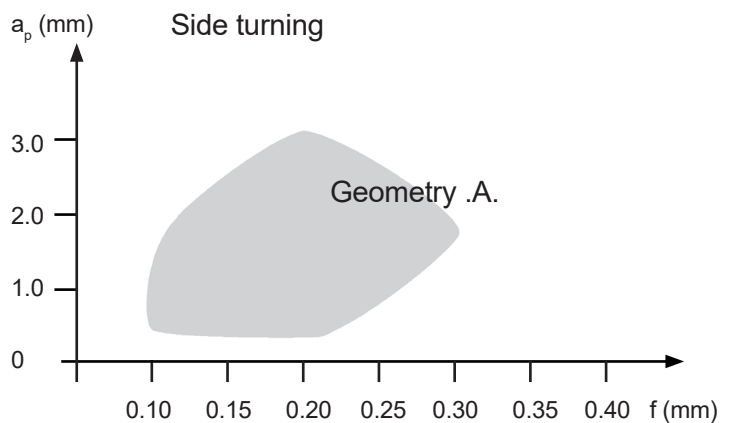

Chip control graph S229.0500.A4 material 16MnCr5

Grooving and Side Turning



Indexable insert

S229

with chip forming

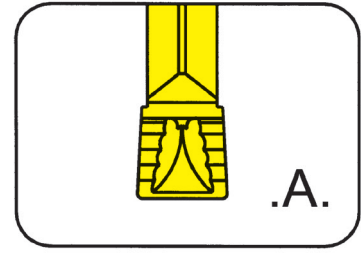

Depth of groove up to
Width of groove

.984"
.118 - .394"

precision sintered

for Toolholder

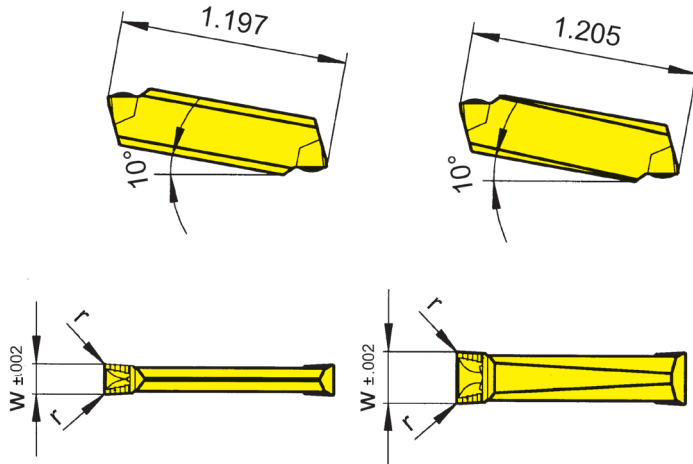

Type 210/U210
218/U218
226/U226
219/U219
213/U213
214/U214
R/LA210
R/LAU210
R/LA226
R/LAU226
257

Indexability length ± .002"

Width = .118 - .197"

Width = .236 - .394"

Part number	w	r	Size	P20	AL96	AS62	TC92	TF42	TF45	TI22	TI25	TN32	TN35	IG66
S229.0300.A2	.118	.008	03	x	x	▲	Δ		▲	▲	▲	▲	▲	
S229.0300.A4	.118	.016	03		x	▲			▲	x	▲	▲	▲	
S229.0400.A2	.157	.008	03/04	x	x	▲	Δ		▲	▲	▲	▲	▲	
S229.0400.A4	.157	.016	03/04		x	▲	Δ	▲	x	▲	▲	▲	▲	
S229.0500.A4	.197	.016	04			▲	Δ		▲	▲	x	▲	▲	▲
S229.0500.A6	.197	.024	04		x	▲	x				▲			▲
S229.0600.A4	.236	.016	05	x	▲	▲	Δ	▲	▲	▲	▲	▲	▲	
S229.0600.A8	.236	.031	05			▲		x						
S229.0700.A6	.276	.024	07				x	▲				▲		
S229.0800.A6	.315	.024	07/08					x		▲		▲		Δ
S229.0800.A8	.315	.031	07/08					x		x				Δ
S229.0800.AK	.315	.047	07/08							x				
S229.1000.A6	.394	.024	09	x			x			x		x		Δ
S229.1000.A8	.394	.031	09				x			x				
				P	•	•	•	•	•	•	•	•	•	•
				M	-	-	-	-	•	-	•	-	•	•
				K	-	•	-	-	•	-	•	-	•	-
				N	-	•	-	-	•	-	•	-	•	-
				S	-	-	-	-	•	-	•	-	•	o
				H	-	-	-	-	-	-	-	-	-	-

▲ on stock Δ 4 weeks x upon request
● recommended
o alternative recommendation
- not suitable

uncoated grades
coated grades
brazed/Cermet

Dimensions in inch

Carbide grades

Indexable inserts can be used in right and left hand toolholders.



Indexable insert

S229

with chip forming

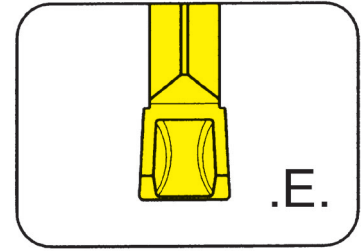

Depth of groove up to .984"
Width of groove .118 - .157"

precision sintered

for Toolholder

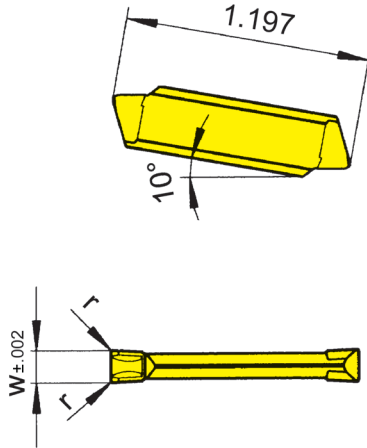

- Type
- 210/U210
 - 218/U218
 - 226/U226
 - 219/U219
 - 213/U213
 - 214/U214
 - R/LA210
 - R/LAU210
 - R/LA226
 - R/LAU226
 - 257

Indexability length ± .002"

H

Part number	w	r	Size	AS62	TC92	TF45	TF46	TI25
				S229.0300.E2	.118	.008	03	▲
S229.0300.E4	.118	.016	03	▲	x	▲		
S229.0400.E2	.157	.008	03/04	▲	x	▲	x	▲
S229.0400.E4	.157	.016	03/04	▲	x	▲		
				P	•	•	•	•
				M	-	-	o	•
				K	-	-	•	•
				N	-	-	•	•
				S	-	-	•	o
				H	-	-	-	-

▲ on stock Δ 4 weeks x upon request

- recommended
- o alternative recommendation
- not suitable

- uncoated grades
- coated grades
- brazed/Cermet

Dimensions in inch

Carbide grades

Indexable inserts can be used in right and left hand toolholders.

Indexable insert

S229

with chip forming

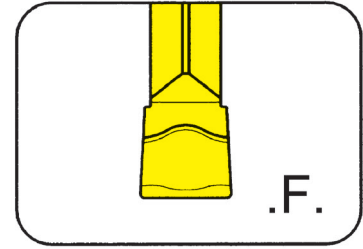

Depth of groove up to .984"
Width of groove .118 - .157"

precision sintered

for Toolholder

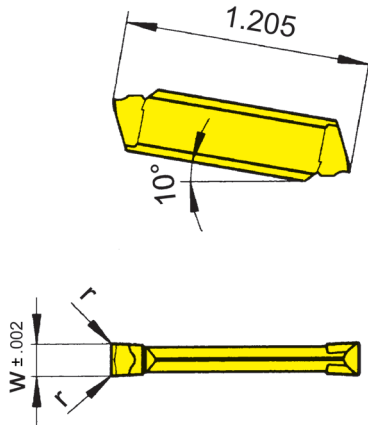

- Type
- 210/U210
 - 218/U218
 - 226/U226
 - 219/U219
 - 213/U213
 - 214/U214
 - R/LA210
 - R/LAU210
 - R/LA226
 - R/LAU226
 - 257

Indexability length ± .002"

Part number	w	r	Size	TC92	TF43	TF45	TF46	TI22	TI25
				S229.0300.F2	.118	.008	03	x	▲
S229.0300.F4	.118	.016	03	x		▲	x		x
S229.0400.F2	.157	.008	03/04	x	x	▲	▲		x
S229.0400.F4	.157	.016	03/04	x		▲	x		x
P	●	●	●	●	●	●	●	●	●
M	-	-	●	○	-	●	-	-	●
K	-	-	●	●	-	●	-	-	●
N	-	-	●	●	-	●	-	-	●
S	-	-	●	○	-	●	-	-	●
H	-	-	-	-	-	-	-	-	-

▲ on stock Δ 4 weeks x upon request
● recommended
○ alternative recommendation
- not suitable
■ uncoated grades
■ coated grades
■ brazed/Cermet

Dimensions in inch

Carbide grades

Indexable inserts can be used in right and left hand toolholders.



Indexable insert

S229

with chip forming

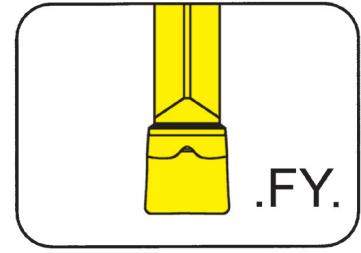

Depth of groove up to	.984"
Width of groove	.118 - .157"

precision sintered

for Toolholder

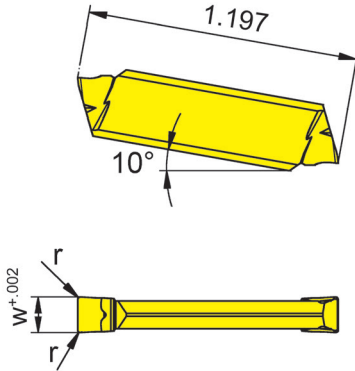

- Type
- 210/U210
 - 218/U218
 - 226/U226
 - 219/U219
 - 213/U213
 - 214/U214
 - R/LA210
 - R/LAU210
 - R/LA226
 - R/LAU226
 - 257

Indexability length $\pm .002''$

Part number	w	r	Size	Carbide grades				
				HP65	IG35	PH35	Ti25	
S229.0300.FY2	.118	.008	03	▲	▲	×	▲	
S229.0400.FY3	.157	.012	03/04	×	▲	▲	▲	
				P	•	-	o	•
				M	•	•	o	•
				K	•	-	•	•
				N	o	-	-	•
				S	•	•	-	•
				H	-	-	-	-

- ▲ on stock Δ 4 weeks x upon request
- recommended
- o alternative recommendation
- not suitable
- uncoated grades
- coated grades
- brazed/Cermet

Dimensions in inch

Carbide grades

Indexable inserts can be used in right and left hand toolholders.



Indexable insert

S229

with chip former

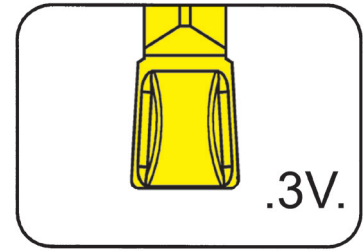

Depth of groove up to
Width of groove

.984"
.118 - .157"

precision sintered

for Toolholder

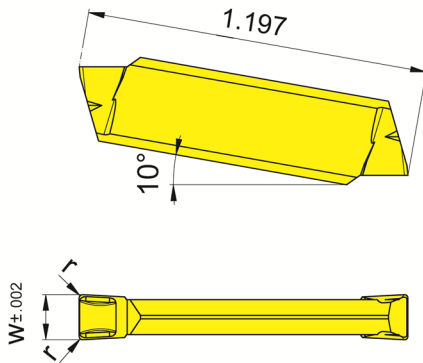

- Type
- 210/U210
 - 218/U218
 - 226/U226
 - 219/U219
 - 213/U213
 - 214/U214
 - R/LA210
 - R/LAU210
 - R/LA226
 - R/LAU226
 - 257

Indexability length $\pm .002''$

Part number	w	r	Size	Carbide grades		
				AS45	HP65	IG35
S229.0300.3V2	.118	.008	03	▲	▲	x
S229.0400.3V3	.157	.012	03/04	▲	▲	x
				P	•	•
				M	•	•
				K	•	•
				N	o	o
				S	•	•
				H	-	-

- ▲ on stock Δ 4 weeks x upon request
- recommended
- o alternative recommendation
- not suitable
- uncoated grades
- coated grades
- brazed/Cermet

Dimensions in inch

Indexable inserts can be used in right and left hand toolholders.



Indexable insert

S229

with chip breaker

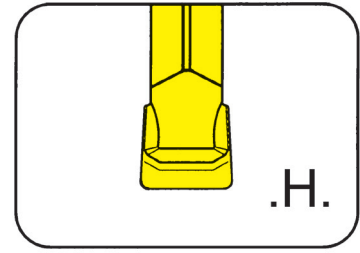

Depth of groove up to
Width of groove

.984"
.118 - .236"

precision sintered

for Toolholder

Type 210/U210
218/U218
226/U226
219/U219
213/U213
214/U214
R/LA210
R/LAU210
R/LA226
R/LAU226
257

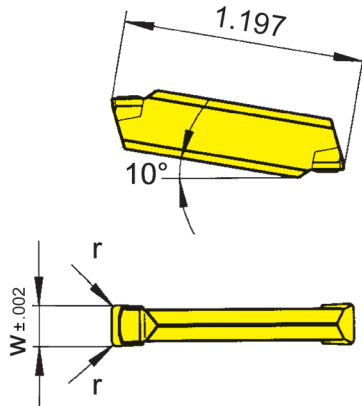

Indexability length $\pm .002''$

H

Part number	w	r	Size	Carbide grades		
				AL96	TF42	TF46
S229.0300.H4	.118	.016	03	▲	▲	
S229.0300.H6	.118	.024	03	▲	▲	
S229.0400.H4	.157	.016	03/04	▲	▲	
S229.0400.H6	.157	.024	03/04	▲	▲	
S229.0400.H8	.157	.031	03/04	▲	▲	x
S229.0500.H4	.197	.016	04	▲	▲	
S229.0500.H6	.197	.024	04	▲	▲	
S229.0500.H8	.197	.031	04	▲	▲	
S229.0600.H4	.236	.016	05	▲	▲	
S229.0600.H6	.236	.024	05	▲	▲	
S229.0600.H8	.236	.031	05	x	▲	
S229.0600.HK	.236	.047	05	x	▲	
P	●	●	●			
M	-	-	o			
K	●	-	●			
N	●	-	●			
S	-	-	o			
H	-	-	-			

▲ on stock Δ 4 weeks x upon request

● recommended

o alternative recommendation

- not suitable

uncoated grades

coated grades

brazed/Cermet

Dimensions in inch

Carbide grades

Indexable inserts can be used in right and left hand toolholders.

Indexable insert

S229

with chip forming

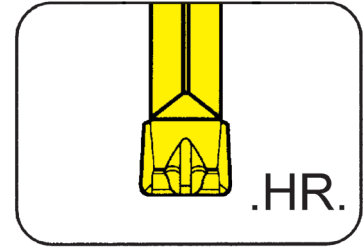

Depth of groove up to .984"
Width of groove .118 - .315"

precision sintered

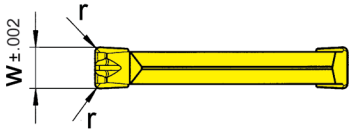
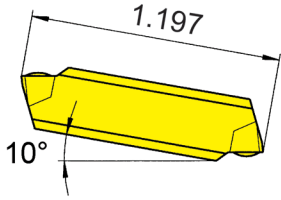

for Toolholder

- Type
- 210/U210
 - 218/U218
 - 226/U226
 - 219/U219
 - 213/U213
 - 214/U214
 - R/LA210
 - R/LAU210
 - R/LA226
 - R/LAU226
 - 257

Indexability length ± .002"

Part number	w	r	Size	AS62	AS66	IG66
S229.0300.HR4	.118	.016	03	▲	x	▲
S229.0400.HR4	.157	.016	03/04	▲	▲	▲
S229.0500.HR4	.197	.016	04	▲	▲	▲
S229.0500.HR6	.197	.024	04	▲	▲	▲
S229.0500.HR8	.197	.031	04	▲	x	▲
S229.0600.HR4	.236	.016	05	▲	▲	▲
S229.0600.HR6	.236	.024	05	▲	▲	▲
S229.0600.HR8	.236	.031	05	▲	x	▲
S229.0800.HR8.PG	.315	.031	07/08	▲	▲	▲
				P	•	•
				M	-	•
				K	-	-
				N	-	•
				S	-	o
				H	-	-

▲ on stock Δ 4 weeks x upon request
 ● recommended
 ○ alternative recommendation
 - not suitable

■ uncoated grades
 ■ coated grades
 ■ brazed/Cermet

Dimensions in inch

Carbide grades

Indexable inserts can be used in right and left hand toolholders.



Indexable insert

S229

with chip forming

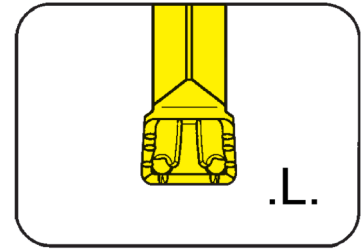

Depth of groove up to
Width of groove

.984"
.157 - .315"

precision sintered

for Toolholder

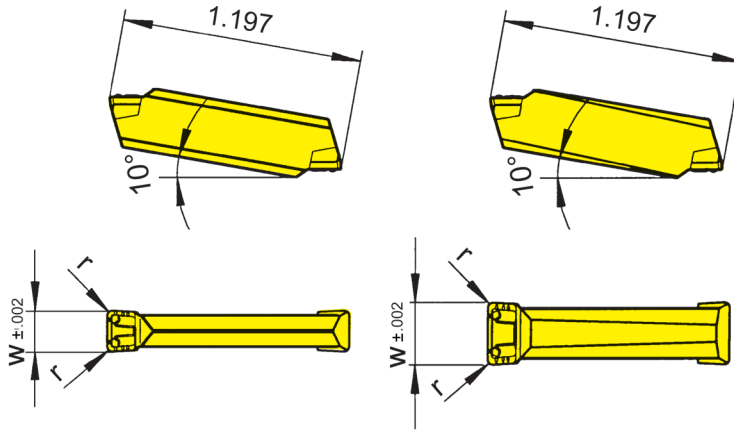

- Type
- 210/U210
 - 218/U218
 - 226/U226
 - 219/U219
 - 213/U213
 - 214/U214
 - R/LA210
 - R/LAU210
 - R/LA226
 - R/LAU226
 - 257

Indexability length ± .002"

Width = .157" - .197"

Width = .236" - .315"

Part number	w	r	Size
S229.0400.L4	.157	.016	03/04
S229.0400.L6	.157	.024	03/04
S229.0500.L4	.197	.016	04
S229.0500.L6	.197	.024	04
S229.0600.L4	.236	.016	05
S229.0500.L8	.197	.031	04
S229.0600.L6	.236	.024	05
S229.0800.L6	.315	.024	07/08

	AL96	AS62	AS66	TF42	TI22	IG66
▲	▲	▲	▲	▲	▲	▲
●	▲	▲	▲	▲	▲	▲
○	▲	▲	▲	▲	▲	▲
-	▲	▲	▲	▲	▲	▲
-	▲	▲	▲	▲	▲	▲
-	▲	▲	▲	▲	▲	▲
-	▲	▲	▲	▲	▲	▲
-	▲	▲	▲	▲	▲	▲
-	▲	▲	▲	▲	▲	▲
P	●	●	●	●	●	●
M	-	-	○	-	-	●
K	●	-	●	-	-	-
N	●	-	●	-	-	-
S	-	-	○	-	-	○
H	-	-	-	-	-	-

- ▲ on stock Δ 4 weeks x upon request
- recommended
- alternative recommendation
- not suitable
- uncoated grades
- coated grades
- brazed/Cermet

Dimensions in inch

Carbide grades

Indexable inserts can be used in right and left hand toolholders.

H

Indexable insert

S229

with chip forming

Depth of groove up to
Width of groove

.984"
.236 - .315"

Precision Ground

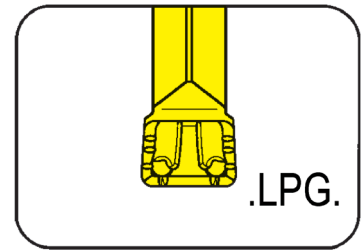

for Toolholder

Type 210/U210
218/U218
226/U226
219/U219
213/U213
214/U214
R/LA210
R/LAU210
R/LA226
R/LAU226
257

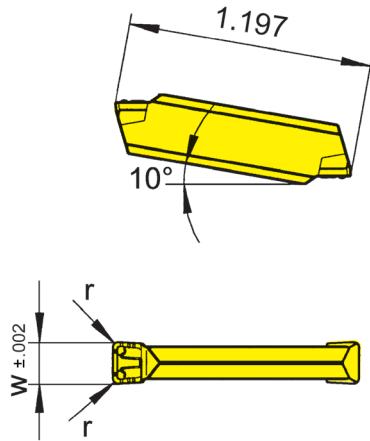

Indexability length $\pm .002''$

PG = inserts with ground periphery

Part number	w	r	Size	Carbide grades	
				AS62	IG66
S229.0600.L4.PG	.236	.016	05	▲	▲
S229.0800.L8.PG	.315	.031	07/08	▲	▲
				P	•
				M	•
				K	-
				N	-
				S	o
				H	-

▲ on stock Δ 4 weeks x upon request
● recommended
o alternative recommendation
- not suitable
□ uncoated grades
■ coated grades
■ brazed/Cermet
Dimensions in inch

Carbide grades

Indexable inserts can be used in right and left hand toolholders.



Indexable insert

S229

with chip forming

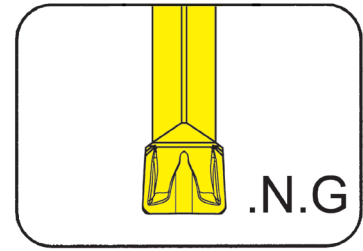

Depth of groove up to
Width of groove

.984"
.118 - .236"

precision sintered

for Toolholder

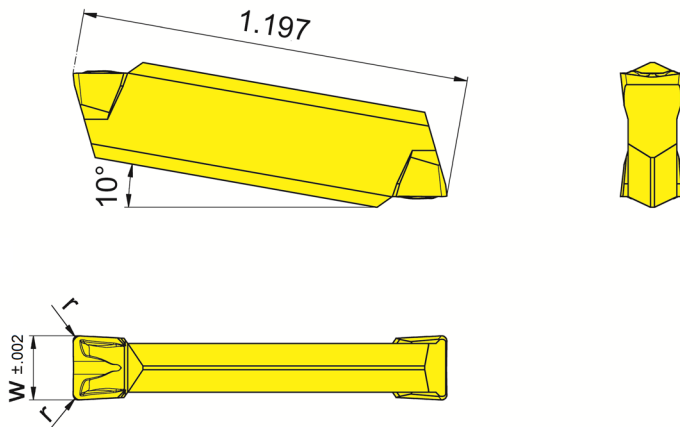

Type 210/U210
218/U218
226/U226
219/U219
213/U213
214/U214
R/LA210
R/LAU210
R/LA226
R/LAU226
257

Indexability length $\pm .002''$

Part number	w	r	Size	Carbide grades				
				AS45	AS62	DD25	TI25	IG66
S229.0300.N2.G	.118	.008	03	▲				▲
S229.0300.N4.G	.118	.016	03	▲				▲
S229.0400.N2.G	.157	.008	03/04	▲				▲
S229.0400.N4.G	.157	.016	03/04	▲				▲
S229.0500.N2.G	.197	.008	04			x	▲	▲
S229.0500.N4.G	.197	.016	04	▲	▲	x	▲	▲
S229.0500.N6.G	.197	.024	04	▲	▲		▲	▲
S229.0500.N8.G	.197	.031	04		▲			▲
S229.0600.N4.G	.236	.016	05	▲			x	▲
S229.0600.N6.G	.236	.024	05	▲			x	▲
				P	•	•	-	•
				M	•	-	-	•
				K	•	-	-	•
				N	o	-	•	-
				S	•	-	o	•
				H	-	-	-	-

▲ on stock Δ 4 weeks x upon request

• recommended

o alternative recommendation

- not suitable

□ uncoated grades

■ coated grades

■ brazed/Cermet

Dimensions in inch

Carbide grades

Indexable inserts can be used in right and left hand toolholders.

Indexable insert

S229

with chip forming

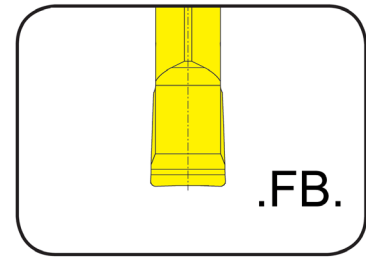

Width of groove	.118 - .157"
-----------------	--------------

Precision Ground

for Toolholder

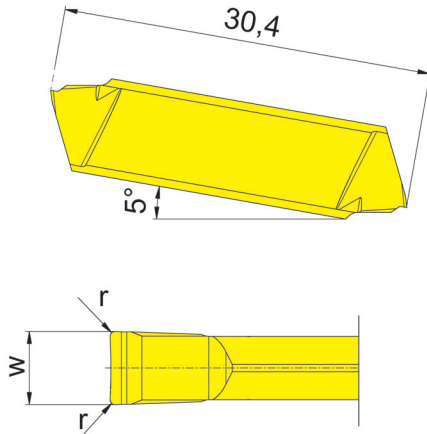

- Type
- 210/U210
 - 218/U218
 - 226/U226
 - 219/U219
 - 213/U213
 - 214/U214
 - R/LA210
 - R/LAU210
 - R/LA226
 - R/LAU226
 - 257

Part number	w	r	Size	H20
S229.FB30.02	.118	.008	03	▲
S229.FB40.02	.157	.008	04	▲

- ▲ on stock Δ 4 weeks x upon request
- recommended
- alternative recommendation
- not suitable
- uncoated grades
- coated grades
- brazed/Cermet

P	●
M	○
K	-
N	-
S	-
H	-

Carbide grades

Dimensions in inch

Indexable inserts can be used in right and left hand toolholders.



Indexable insert

S229

with chip forming

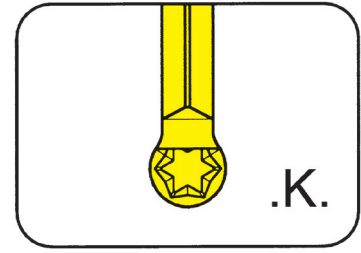

Depth of groove up to	.984"
Width of groove	.118 - .315"
Full radius	.059 - .157"

precision sintered

for Toolholder

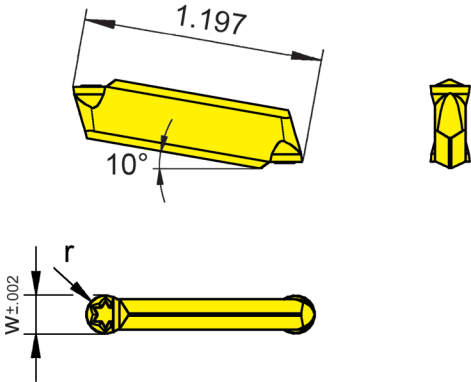

- Type
- 210/U210
 - 218/U218
 - 226/U226
 - 219/U219
 - 213/U213
 - 214/U214
 - R/LA210
 - R/LAU210
 - 225/U225
 - R/LA226
 - R/LAU226
 - 257

Indexability length ± .002"

Part number	w	r	Size	Carbide grades		
				AS62	AS66	IG66
S229.0015.K3	.118	.059	02/03	▲	▲	▲
S229.0020.K4	.157	.079	03/04	▲	▲	▲
S229.0025.K5	.197	.098	04	▲	▲	▲
S229.0030.K6	.236	.118	05	▲	▲	▲
S229.0040.K8	.315	.157	07/08	▲	▲	▲
				P	•	•
				M	-	•
				K	-	-
				N	-	•
				S	-	o
				H	-	-

- ▲ on stock Δ 4 weeks x upon request
- recommended
- o alternative recommendation
- not suitable
- uncoated grades
- coated grades
- brazed/Cermet

Dimensions in inch

Carbide grades

Indexable inserts can be used in right and left hand toolholders.

Dmin for corner reliefs with 45° toolholder

t _{max}	S229.0015.K3	S229.0020.K4	S229.0025.K5	S229.0030.K6
.02	Ø 1.024	Ø 1.024	Ø 1.260	Ø 1.260
.039	Ø 2.992	Ø 2.165	Ø 1.654	Ø 1.457
.059	Ø 3.071	Ø 2.283	Ø 1.772	Ø 1.614
.079	Ø 3.150	Ø 2.323	Ø 1.811	Ø 1.654
.098	Ø 3.228	Ø 2.362	Ø 1.850	Ø 1.693
.118	Ø 3.307	Ø 2.441	Ø 1.890	Ø 1.732
.138	Ø 3.425	Ø 2.480	Ø 1.929	Ø 1.811
.157	Ø 3.504	Ø 2.559	Ø 1.969	Ø 1.850

Indexable insert

S229

with chip forming

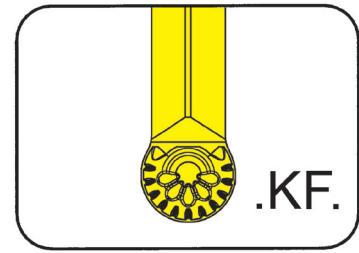

Depth of groove up to
Width of groove
Full radius

.984"
.118 - .315"
.059 - .157"

precision sintered

for Toolholder

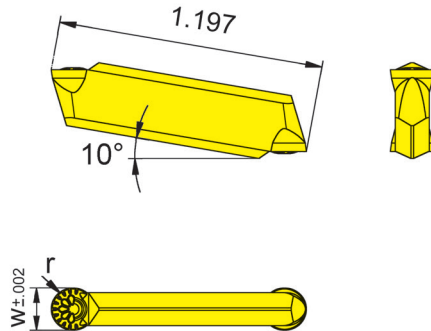

Type 210/U210
218/U218
226/U226
219/U219
213/U213
214/U214
R/LA210
R/LAU210
225/U225
R/LA226
R/LAU226
257

Indexability length $\pm .002''$

Part number	w	r	Size	Carbide grades	
				AS66	IG66
S229.0015.KF3	.118	.059	02/03	▲	▲
S229.0020.KF4	.157	.079	03/04	▲	▲
S229.0025.KF5	.197	.098	04	▲	▲
S229.0030.KF6	.236	.118	05	▲	▲
S229.0040.KF8	.315	.157	07/08	▲	▲

▲ on stock Δ 4 weeks x upon request

● recommended

○ alternative recommendation

- not suitable

□ uncoated grades

■ coated grades

■ brazed/Cermet

Dimensions in inch

	AS66	IG66
P	●	●
M	○	●
K	●	-
N	●	-
S	○	○
H	-	-

Carbide grades

Indexable inserts can be used in right and left hand toolholders.

Dmin for corner reliefs with 45° toolholder

t _{max}	S229.0015.KF3	S229.0020.KF4	S229.0025.KF5	S229.0030.KF6
.02	Ø 1.024	Ø 1.024	Ø 1.260	Ø 1.260
.039	Ø 2.992	Ø 2.165	Ø 1.654	Ø 1.457
.059	Ø 3.071	Ø 2.283	Ø 1.772	Ø 1.614
.079	Ø 3.150	Ø 2.323	Ø 1.811	Ø 1.654
.098	Ø 3.228	Ø 2.362	Ø 1.850	Ø 1.693
.118	Ø 3.307	Ø 2.441	Ø 1.890	Ø 1.732
.138	Ø 3.425	Ø 2.480	Ø 1.929	Ø 1.811
.157	Ø 3.504	Ø 2.559	Ø 1.969	Ø 1.850

Indexable insert

229...10

Precision Ground



Geometry .10

Easy cutting geometry without chip former

Characteristics

- Easy cutting - low power requirement
- Suitable for unstable parts
- For internal grooving in restricted bores
- Suitable for low feeds

Applications

- Grooving:
Depth of groove up to 18 mm

Feed Rate f

- Grooving: up to 0.3 mm/rev

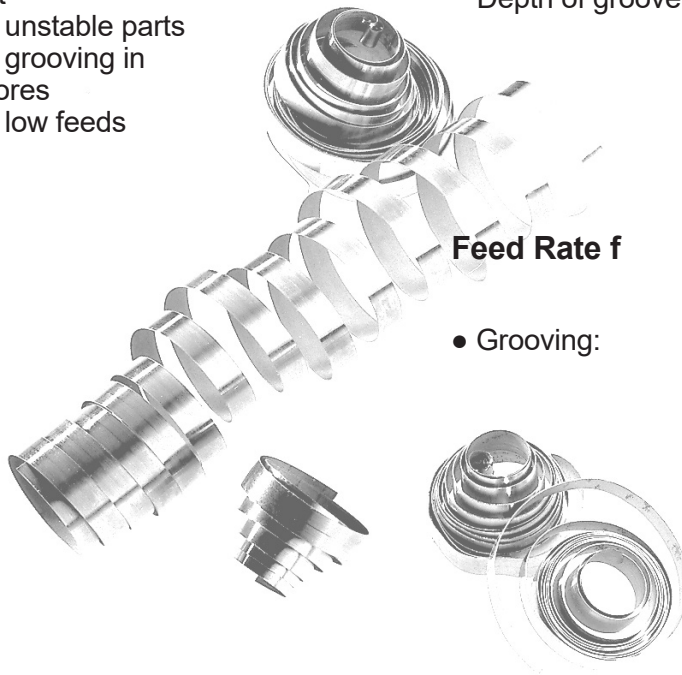

Profiling with a cutting depth of the edge radius is possible.
Indexable inserts with profiles, intermediate sizes or other edge radii are available upon request.
Indexable inserts can be used in **right and left hand** toolholders.

Grooving and Side Turning



Indexable insert

229

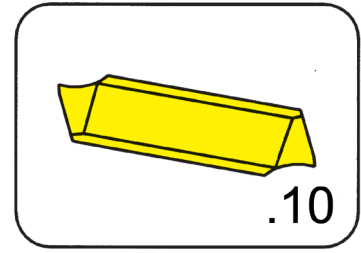

Depth of groove up to .984"
Width of groove .098 - .394"

precision ground

for Toolholder

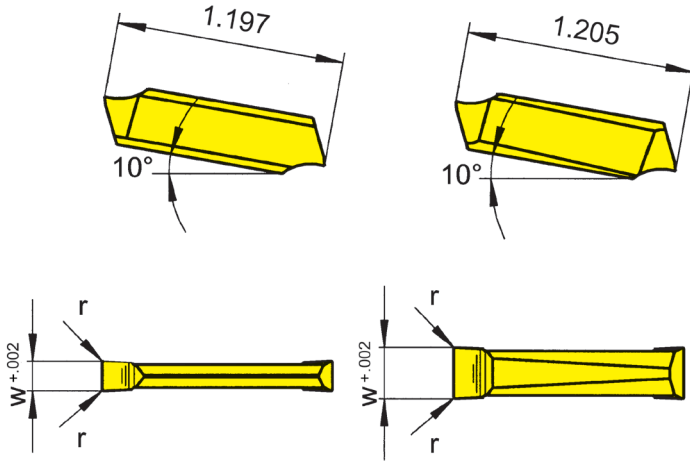

- Type
- 210/U210
 - 218/U218
 - 226/U226
 - 219/U219
 - 213/U213
 - 214/U214
 - R/LA210
 - R/LAU210
 - R/LA226
 - R/LAU226
 - 257

Indexability length $\pm .001''$

Width of groove .098 - .197"

Width of groove .201 - .409"

Part number	w	r	Size	K10	MG12	P20	AS62	TC92	TN32	TN35	H20	IG66
229.0250.10	.098	.008	02						▲	▲		▲
229.0300.10	.118	.008	03	▲	▲	▲	▲	△	▲	▲	▲	▲
229.0400.10	.157	.008	03/04	▲		▲	▲	△	▲	x		▲
229.0500.10	.197	.008	04	▲		▲	▲	△	▲	x		△
229.0600.10	.236	.016	05	x		x		x	x	x		△
229.0700.10	.276	.016	07	x		x		x	x	x		△
229.0800.10	.315	.016	07/08	x		x		x	x	x		△
229.0900.10	.354	.016	09	x		x		x	x	x		△
229.1000.10	.394	.016	09	x		x		x	x	x		△
				P	●	○	●	●	●	●	●	●
				M	○	-	-	-	-	●	○	●
				K	●	-	-	-	-	●	-	-
				N	●	-	-	-	-	●	-	-
				S	○	-	-	-	-	●	-	○
				H	-	-	-	-	-	-	-	-

▲ on stock Δ 4 weeks x upon request
● recommended
○ alternative recommendation
- not suitable
■ uncoated grades
■ coated grades
■ brazed/Cermet

Dimensions in inch

Carbide grades

Indexable inserts can be used in right and left hand toolholders.



Indexable Insert

229...20

Precision Ground



Geometry .20.

Geometry without chip forming for grey cast iron and materials with higher tensile strength

Characteristics

- Strong wedge angle
- For inserts with larger depth of profile
- Recommended for interrupted cut
- Suitable for low feeds

Applications

- Grooving:
Depth of groove up to 25 mm

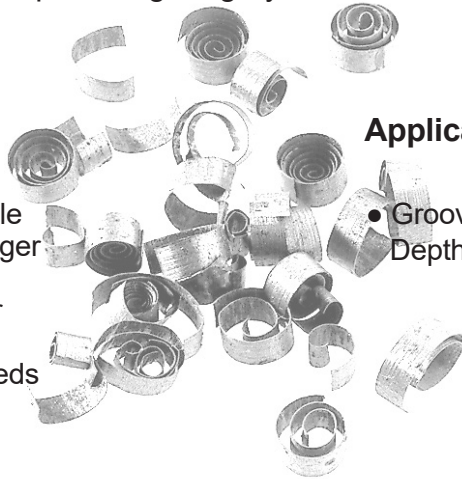

Feed Rate f

- Grooving: 0.07 up to 0.25 mm/rev

H

Profiling with a cutting depth of the edge radius is possible.
Indexable inserts with profiles, intermediate sizes or other edge radii are available upon request.
Indexable inserts can be used in **right and left hand** toolholders.

Indexable insert

229

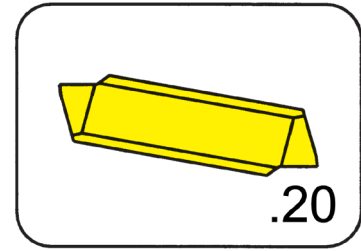

Depth of groove up to .984"
Width of groove .118 - .394"

precision ground

for Toolholder

- Type
- 210/U210
 - 218/U218
 - 226/U226
 - 219/U219
 - 213/U213
 - 214/U214
 - R/LA210
 - R/LAU210
 - R/LA226
 - R/LAU226
 - 257

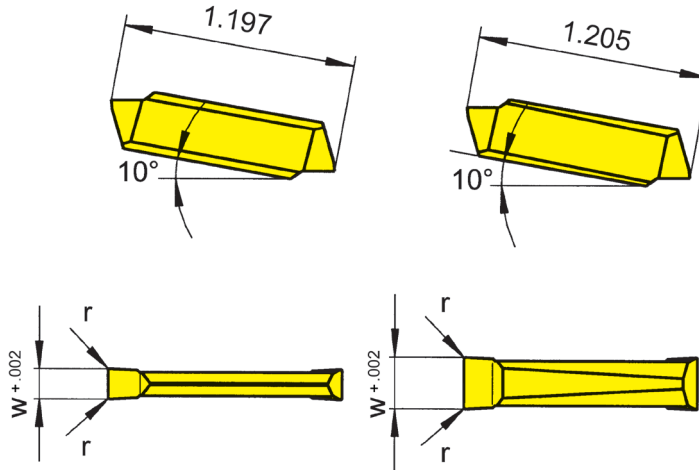

Width of groove = .118 - .197"

Width of groove .201 - .409"

Indexability length $\pm .001''$

Part number	w	r	Size	K10	AS62	TC92	TN32	H20	IG66
229.0300.20	.118	.008	03	▲	▲	▲		▲	▲
229.0400.20	.157	.008	03/04	▲	▲	▲	▲		▲
229.0500.20	.197	.008	04	▲	▲	▲			▲
229.0600.20	.236	.016	05	▲	▲	▲			▲
229.0700.20	.276	.016	07	▲					▲
229.0800.20	.315	.016	07/08	▲					▲
229.0900.20	.354	.016	09	x					▲
229.1000.20	.394	.016	09	x					▲
▲ on stock Δ 4 weeks x upon request				P	●	●	●	●	●
● recommended				M	○	-	-	○	●
○ alternative recommendation				K	●	-	-	-	-
- not suitable				N	●	-	-	-	-
■ uncoated grades				S	○	-	-	-	○
■ coated grades				H	-	-	-	-	-
■ brazed/Cermet				Carbide grades					

Dimensions in inch

Indexable inserts can be used in right and left hand toolholders.



Indexable insert

229...3.

Precision Ground

Geometry .3.



Geometry with chip forming for all materials.

Characteristics

- Excellent swarf control
- Suitable for high alloy- high strength steels
- Reduced swarf width gives high flank surface finish
- Excellent swarf control allows production security

Applications

- Grooving:
Depth of groove up to 25 mm
- Side turning:
Depth of cut a_p up to 4 mm*



Feed Rate f

- Grooving: 0.15 up to 0.25 mm/rev*
- Side turning: up to 0.4 mm/rev*

* dependent upon width of insert

Indexable inserts with profiles, intermediate sizes or other edge radii are available upon request. Indexable inserts can be used in **right and left hand** toolholders.

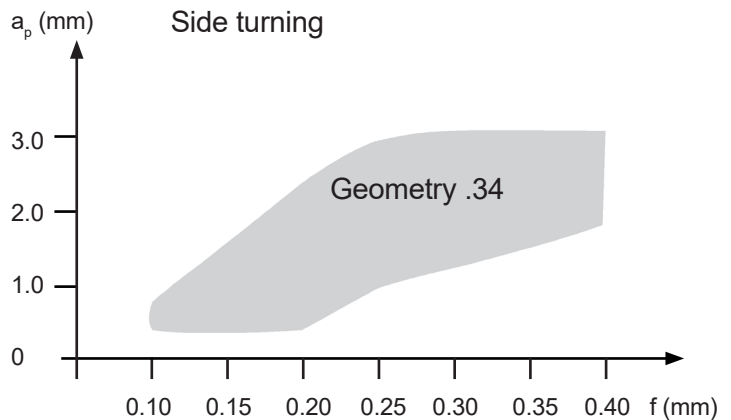

Chip control graph 229.0500.34 material 16MnCr5

Grooving and Side Turning



Indexable insert

229

with chip former

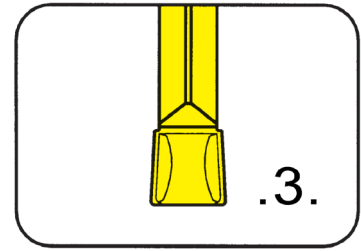

Depth of groove up to
Width of groove

.984"
.118 - .394"

precision ground

for Toolholder

Type 210/U210
218/U218
226/U226
219/U219
213/U213
214/U214
R/LA210
R/LAU210
R/LA226
R/LAU226
257

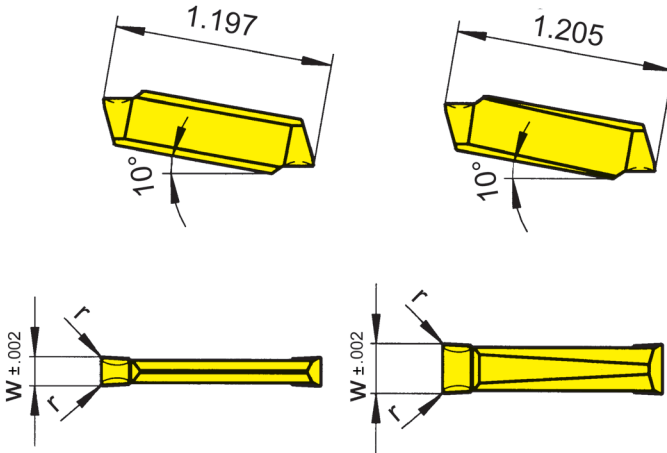

Width of groove = .118 - .197"

Width of groove .201 - .409"

Indexability length ± .001"

Part number	w	r	Size	K10	MG12	P20	AS62	TC92	TI22	TI25	TN32	TN35	IG66
229.0300.31	.118	.008	03	▲	▲	▲	▲	△		▲	▲	▲	▲
229.0300.34	.118	.016	03			x	▲	△			▲	▲	▲
229.0350.31	.138	.008	03					▲			▲		▲
229.0400.31	.157	.008	03/04	▲		▲	▲	△			▲		▲
229.0400.34	.157	.016	03/04			▲	▲	△			▲	▲	▲
229.0500.31	.197	.008	04	▲		▲	▲	△	▲		▲		▲
229.0500.34	.197	.016	04			x	▲	△			▲	▲	△
229.0500.36	.197	.024	04					x			x		△
229.0600.31	.236	.016	05			▲	▲	△			▲		△
229.0600.38	.236	.031	05				▲	△			x		△
229.0700.31	.276	.016	07			▲	▲	x			▲		△
229.0800.31	.315	.016	07/08			▲	▲	△			▲		△
229.0900.31	.354	.016	09			x	▲	△			▲		△
229.1000.31	.394	.016	09			x	▲	x			▲	▲	△
P	●	○	●	●	●	●	●	●	●	●	●	●	●
M	○	-	-	-	-	-	-	-	-	●	-	-	●
K	●	-	-	-	-	-	-	-	-	●	-	●	-
N	●	-	-	-	-	-	-	-	-	●	-	●	-
S	○	-	-	-	-	-	-	-	-	●	-	●	○
H	-	-	-	-	-	-	-	-	-	-	-	-	-

▲ on stock △ 4 weeks x upon request
● recommended
○ alternative recommendation
- not suitable

uncoated grades
coated grades
brazed/Cermet

Dimensions in inch

Carbide grades

Indexable inserts can be used in right and left hand toolholders.



Indexable insert

229

with chip breaker

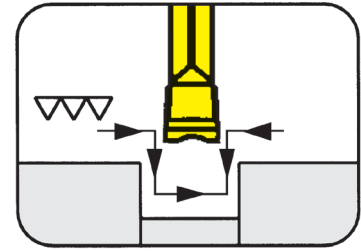

Depth of groove up to
Width of groove

.984"
.118 - .157"

precision ground

for Toolholder

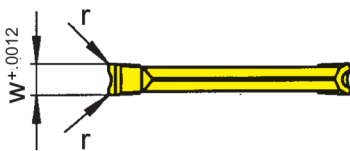
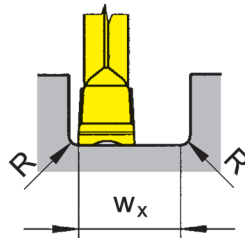
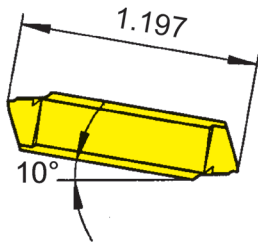

- Type
- 210/U210
 - 218/U218
 - 226/U226
 - 219/U219
 - 213/U213
 - 214/U214
 - R/LA210
 - R/LAU210
 - R/LA226
 - R/LAU226
 - 257

Indexability length \pm .001"

Part number	w	r	w _x	Size	H20
229.NC30.02	.118	.008	.177	03/04	▲
229.NC40.02	.157	.008	.252	03/04	▲

▲ on stock Δ 4 weeks x upon request

- recommended
- alternative recommendation
- not suitable

- uncoated grades
- coated grades
- brazed/Cermet

Dimensions in inch

P	●
M	○
K	-
N	-
S	-
H	-

Carbide grades

w_x = width of groove - R_(right) - R_(left)

Indexable inserts can be used in right and left hand toolholders.

Indexable insert

229

Depth of groove up to .984"
Width of groove .118 - .157"

precision ground

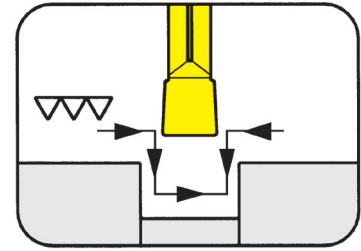

for Toolholder

- Type
- 210/U210
 - 218/U218
 - 226/U226
 - 219/U219
 - 213/U213
 - 214/U214
 - R/LA210
 - R/LAU210
 - R/LA226
 - R/LAU226
 - 257

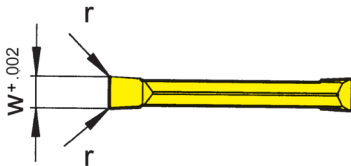
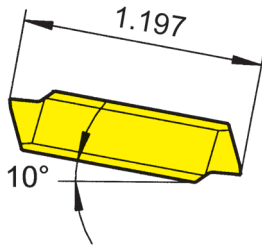

Indexability length \pm .001"

Part number	w	r	Size	Carbide grades	
				TN32	H20
229.0300.02	.118	.008	03/04	•	•
229.0400.02	.157	.008	03/04	x	•
				P	•
				M	o
				K	-
				N	-
				S	-
				H	-

- ▲ on stock Δ 4 weeks x upon request
- recommended
- o alternative recommendation
- not suitable
- uncoated grades
- coated grades
- brazed/Cermet

Dimensions in inch

Carbide grades

Indexable inserts can be used in right and left hand toolholders.



Grooving (external and internal)



Indexable insert

229

with surrounding chip breaker

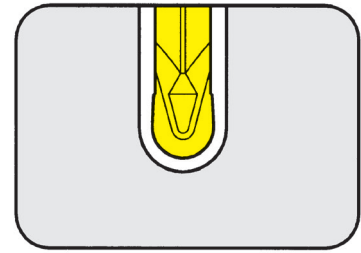

Depth of groove up to .984"
Full radius .059 - .118"

precision ground

for Toolholder

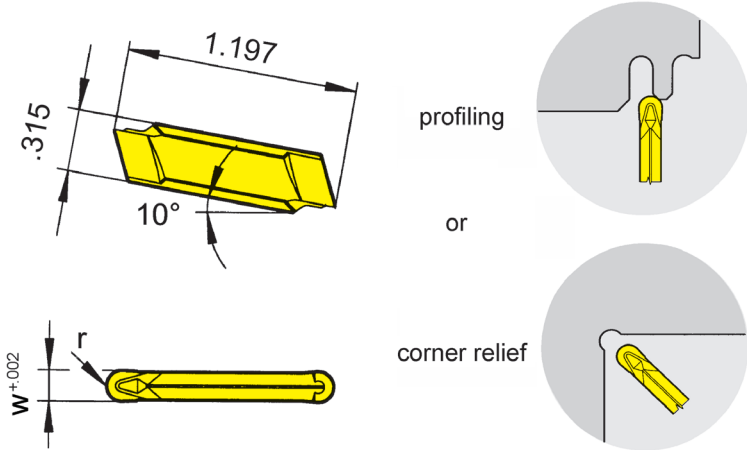

- Type
- 210/U210
 - 218/U218
 - 226/U226
 - 219/U219
 - 213/U213
 - 214/U214
 - R/LA210
 - R/LAU210
 - 225/U225
 - R/LA226
 - R/LAU226
 - 257

Indexability length ± .001"

H

Part number	w	r	Size	Clamping range	MG12	P20	AS62	AS66	TN32	H20
229.0015.30	.118	.059	225...04	03 - 05	▲	▲	▲		▲	▲
			...03	03 - 05						
229.0020.40	.157	.079	225...04	3.0 - 5.0	▲	▲	▲		▲	
			...03	3.0 - 4.0						
			...04	4.0 - 5.0						
229.0025.50	.197	.098	225...04	3.0 - 5.0	▲	▲	x	▲	▲	
			...04	3.0 - 4.0						
229.0030.60	.236	.118	...05	5.1 - 6.0		▲	▲	▲		

▲ on stock Δ 4 weeks x upon request

- recommended
- alternative recommendation
- not suitable

- uncoated grades
- coated grades
- brazed/Cermet

Dimensions in inch

	P	M	K	N	S	H
MG12	○	●	●	●	●	●
P20	-	-	-	○	-	○
AS62	-	-	-	●	-	-
AS66	-	-	○	-	-	-
TN32	-	-	-	-	-	-
H20	-	-	-	-	-	-

Carbide grades

Indexable inserts can be used in right and left hand toolholders.

Threading (external) Full profile



Indexable insert

229

Metric ISO-thread

Pitch	.039 - .098"
-------	--------------

precision ground

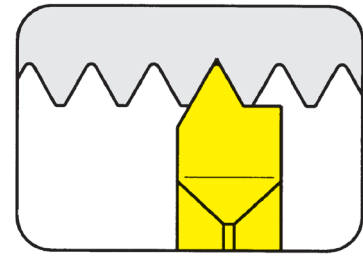

for Toolholder

- Type
- 210/U210
 - 218/U218
 - 226/U226
 - 219/U219
 - 213/U213
 - 214/U214
 - R/LA210
 - R/LAU210
 - R/LA226
 - R/LAU226
 - 257

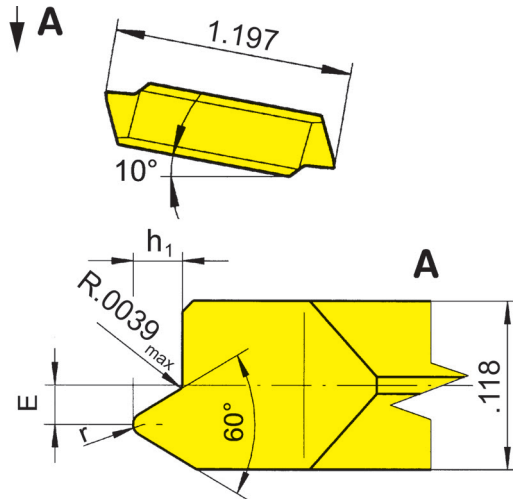

R = right hand version shown

L = left hand version

Indexability length $\pm .001''$

Part number	P mm	E	h ₁	Size	TN35
R/L229.0610.02	1.00	.031	.024	03/04	▲▲
R/L229.0712.02	1.25	.031	.031	03/04	▲▲
R/L229.0915.02	1.50	.028	.037	03/04	▲▲
R/L229.1017.02	1.75	.020	.043	03/04	▲▲
R/L229.1220.02	2.00	.020	.049	03/04	▲▲
R/L229.1525.02	2.50	.012	.061	03/04	▲▲

▲ on stock Δ 4 weeks x upon request

- recommended
- alternative recommendation
- not suitable

- uncoated grades
- coated grades
- brazed/Cermet

Dimensions in inch

P	•
M	•
K	•
N	•
S	•
H	-

Carbide grades

State R or L version

No shims necessary. All HORN thread profiles are manufactured with **fully ground radial clearance**.

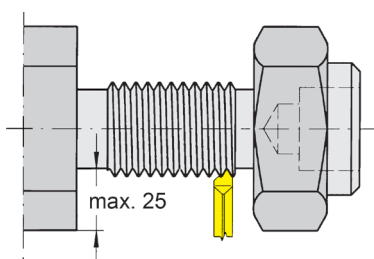

Suitable for threading behind a shoulder

Call Us Toll Free (888) 818-4676

H85



Threading (external) Partial profile



Indexable insert

229

Metric ISO-thread

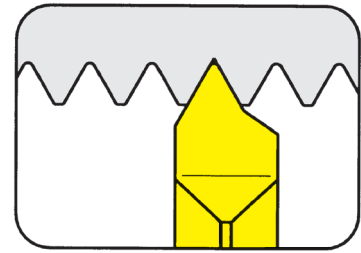

Pitch	.039 - .098"
-------	--------------

precision ground

for Toolholder

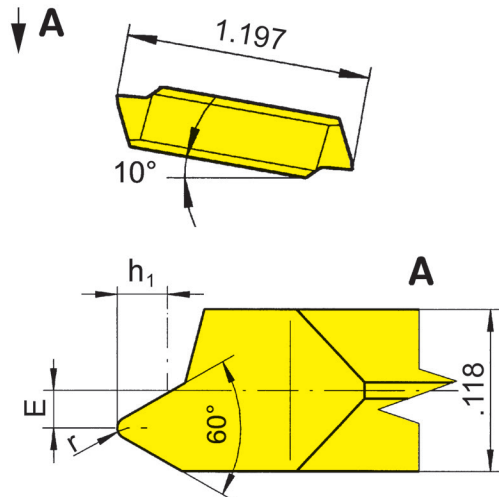

- Type
- 210/U210
 - 218/U218
 - 226/U226
 - 219/U219
 - 213/U213
 - 214/U214
 - R/LA210
 - R/LAU210
 - R/LA226
 - R/LAU226
 - 257

Indexability length $\pm .001''$

R = right hand version shown

L = left hand version

Part number	P mm	E	h ₁	Size	TN35
R/L229.0610.01	1.00	.031	.024	03/04	▲/▲
R/L229.0712.01	1.25	.031	.030	03/04	▲/△
R/L229.0915.01	1.50	.028	.036	03/04	▲/▲
R/L229.1017.01	1.75	.020	.042	03/04	▲/▲
R/L229.1220.01	2.00	.020	.048	03/04	▲/▲
R/L229.1525.01	2.50	.012	.060	03/04	▲/△

▲ on stock Δ 4 weeks x upon request

- recommended
- alternative recommendation
- not suitable

- uncoated grades
- coated grades
- brazed/Cermet

Dimensions in inch

P	•
M	•
K	•
N	•
S	•
H	-

Carbide grades

State R or L version

No shims necessary. All HORN thread profiles are manufactured with **full ground radial clearance**.

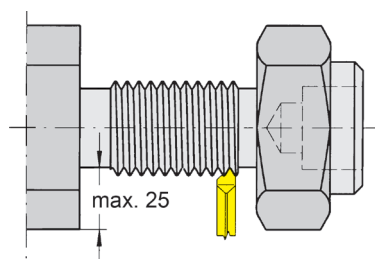

Suitable for threading behind a shoulder

Threading (external) Full profile



Indexable insert

N229

Whitworth pipe thread

Threads per inch	11 - 28
------------------	---------

precision ground

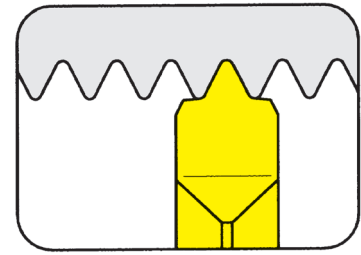

for Toolholder

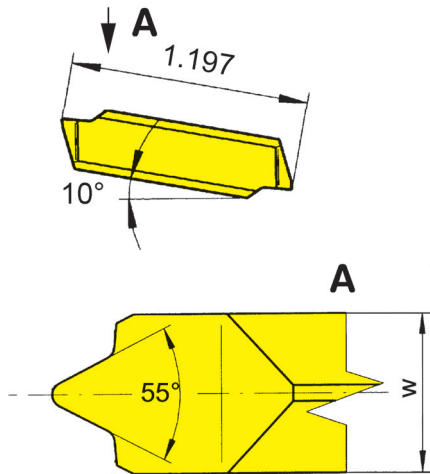

- Type
- 210/U210
 - 218/U218
 - 226/U226
 - 219/U219
 - 213/U213
 - 214/U214
 - R/LA210
 - R/LAU210
 - R/LA226
 - R/LAU226
 - 257

Indexability length $\pm .001''$

Part number	TPI	s	Size	Carbide grades			
				K10	MG12	TA45	TN35
N229.5511.02	11	.138	03/04		x	Δ	▲
N229.5514.02	14	.118	03/04	x	x	▲	▲
N229.5519.02	19	.118	03/04		x	x	▲
N229.5528.02	28	.118	03/04		x		▲
				P	o	•	•
				M	o	-	•
				K	•	-	•
				N	•	-	•
				S	o	-	•
				H	-	-	-

▲ on stock Δ 4 weeks x upon request

- recommended
- o alternative recommendation
- not suitable

- uncoated grades
- coated grades
- brazed/Cermet

Dimensions in inch

Carbide grades

No shims necessary. All HORN thread profiles are manufactured with **full ground radial clearance**.

Indexable inserts can be used in right and left hand toolholders.

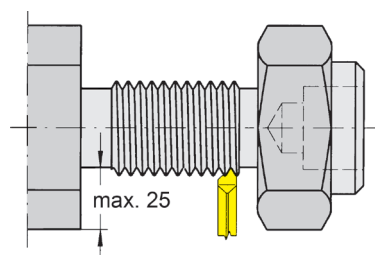

Suitable for threading behind a shoulder

Indexable insert

229

with chip former

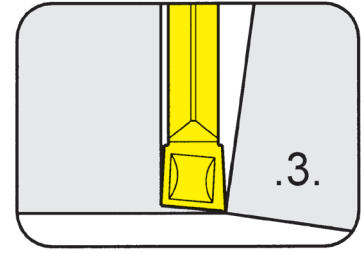

Depth of groove up to .984"
Width of groove .118 - .157"

precision sintered

for Toolholder

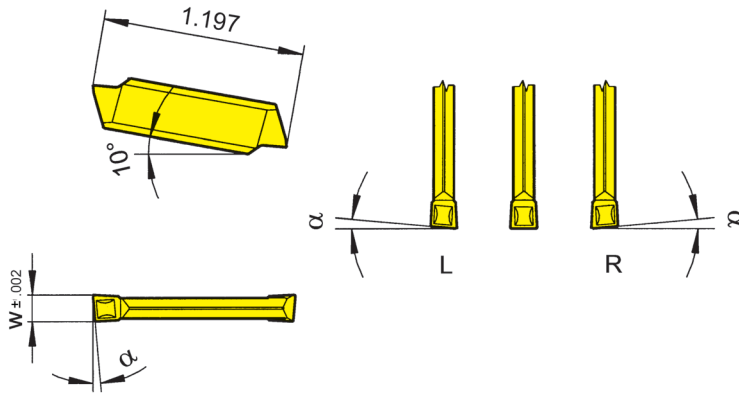

- Type
- 210/U210
 - 218/U218
 - 226/U226
 - 219/U219
 - 213/U213
 - 214/U214
 - R/LA210
 - R/LAU210
 - R/LA226
 - R/LAU226
 - 257

Indexability length ± .002"

R = right hand version shown

L = left hand version

H

Part number	w	r	α	Size	Carbide grades													
					MG12	P20	AL96	AS62	AS66	H54	TA45	TC92	TF45	TI22	TI25	TN32	TN35	
R/L229.5300.31	.118	.008	5°	03	▲/▲				▲/▲				Δ/Δ			▲/▲	▲/▲	▲/▲
R/LS229.0530.32	.118	.008	5°	03				▲/▲				x/x	Δ/Δ	▲/▲		▲/▲	▲/▲	▲/▲
S229.0300.32	.118	.008	-	03	▲	x	▲	▲	▲	▲	x	Δ	▲	▲	▲	▲	▲	▲
R/LS229.0540.32	.157	.008	5°	03/04				▲/▲			x/x	x/x	▲/▲		▲/▲	▲/▲	▲/▲	x/x
S229.0400.32	.157	.008	-	03/04	x	x	▲	▲	▲	▲	x	Δ	▲	x	▲	▲	▲	▲
					P	o	•	•	•	•	•	•	•	•	•	•	•	•
					M	-	-	-	-	o	•	•	-	-	-	•	-	•
					K	-	-	•	-	•	-	•	-	•	-	•	-	•
					N	-	-	•	-	•	-	•	-	•	-	•	-	•
					S	-	-	-	-	o	-	•	-	•	-	•	-	•
					H	-	-	-	-	-	-	-	-	-	-	-	-	-

▲ on stock Δ 4 weeks x upon request
 • recommended
 o alternative recommendation
 - not suitable
 uncoated grades
 coated grades
 brazed/Cermet

Dimensions in inch

Carbide grades

State R or L version

Note:

R/L229.5300.31 precision ground, length 1.181"

Indexable inserts can be used in right and left hand toolholders.

Indexable insert

S229

with chip forming

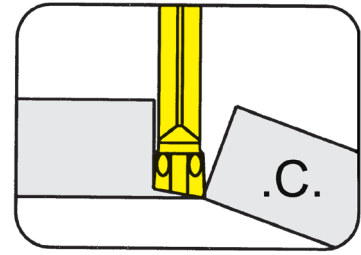

Depth of groove up to
Width of groove

.984"
.118 - .157"

precision sintered

for Toolholder

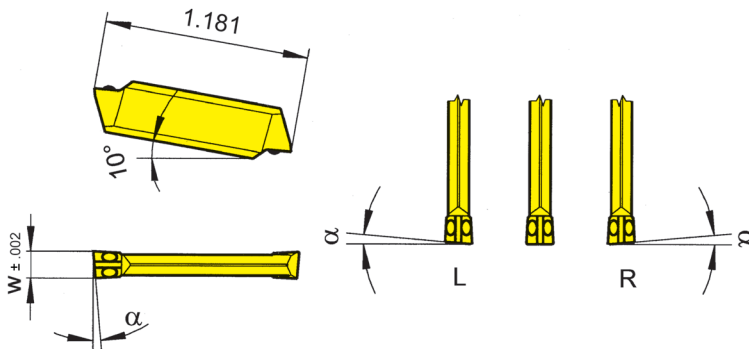

Type 210/U210
218/U218
226/U226
219/U219
213/U213
214/U214
R/LA210
R/LAU210
R/LA226
R/LAU226
257

Indexability length \pm .001"

R = right hand version shown

L = left hand version

Part number	w	α	Size	TC92	TF45	TI25	TN35
R/LS229.0530.C0	.118	5°	03	x/x	▲/▲	▲/▲	▲/▲
R/LS229.0830.C0	.118	8°	03	▲/▲	▲/▲	▲/▲	▲/▲
S229.0030.C0	.118	0°	03	x	▲	▲	▲
R/LS229.0540.C0	.157	5°	03/04	x/x	x/x	Δ/x	▲/x
R/LS229.0840.C0	.157	8°	03/04	x/x	x/x	▲/x	▲/Δ
S229.0040.C0	.157	0°	03/04	x	x	▲	▲
				P	•	•	•
				M	-	•	•
				K	-	•	•
				N	-	•	•
				S	-	•	•
				H	-	-	-

▲ on stock Δ 4 weeks x upon request

• recommended

o alternative recommendation

- not suitable

uncoated grades

coated grades

brazed/Cermet

Dimensions in inch

State R or L version

Indexable inserts can be used in right and left hand toolholders.

Carbide grades



Indexable insert

S229

with chip forming

Depth of groove up to
Width of groove

.984"
.118 - .157"

precision sintered

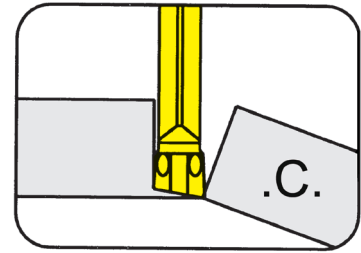

for Toolholder

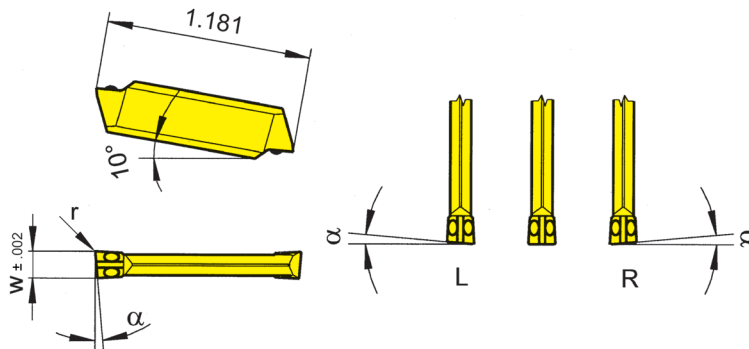

Type 210/U210
218/U218
226/U226
219/U219
213/U213
214/U214
R/LA210
R/LAU210
R/LA226
R/LAU226
257

Indexability length ± .001"

R = right hand version shown

L = left hand version

Part number	w	r	α	Size	Carbide grades			
					TC92	TF45	TI25	TN35
R/LS229.0530.C1	.118	.006	5°	03	x/x	x/x	▲/▲	▲/▲
R/LS229.0830.C1	.118	.006	8°	03	x/x	▲/▲	▲/Δ	▲/▲
S229.0030.C1	.118	.006	0°	03	x	▲	▲	▲
R/LS229.0540.C1	.157	.006	5°	03/04	x/x	x/x	Δ/x	Δ/x
R/LS229.0840.C1	.157	.006	8°	03/04	x/x	x/x	x/x	▲/Δ
S229.0040.C1	.157	.006	0°	03/04	x	Δ	Δ	x
					P	•	•	•
					M	-	•	•
					K	-	•	•
					N	-	•	•
					S	-	•	•
					H	-	-	-

▲ on stock Δ 4 weeks x upon request

• recommended
o alternative recommendation
- not suitable

□ uncoated grades
■ coated grades
■ brazed/Cermet

Dimensions in inch

State R or L version

Indexable inserts can be used in right and left hand toolholders.

Grooving and Parting Off



Toolholder

H259

Machining brass

Depth of groove up to
Width of groove

18 mm
3 - 4 mm

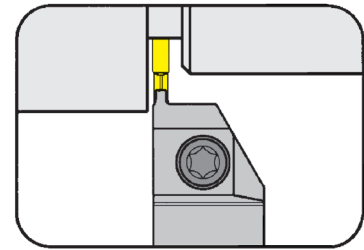

for Indexable insert

Type 259

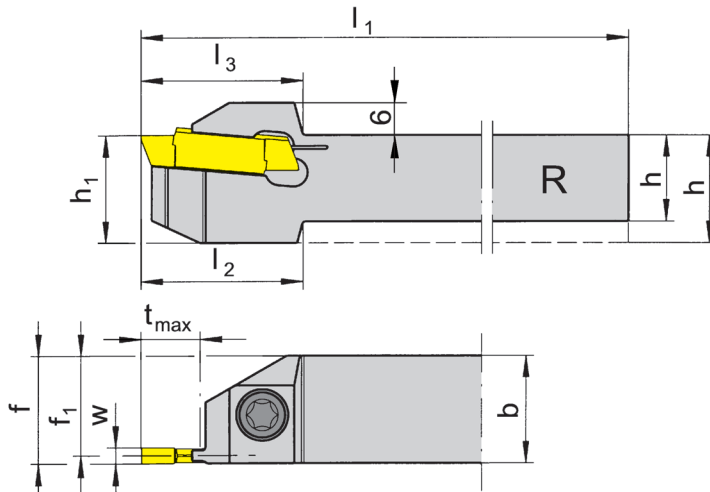

R = right hand version shown

L = left hand version

Part number	h	b	l_1	l_2	l_3	h_1	f	f_1	t_{max}	Size
R/LH259.1616.03	16	16	135	30	30	20	$f_1+w/2$	14.55	11	03
R/LH259.2020.03	20	20	135	-	30	20	$f_1+w/2$	18.55	11	03
R/LH259.2525.03	25	25	135	-	30	25	$f_1+w/2$	23.55	11	03
R/LH259.1616.13	16	16	135	33	33	20	$f_1+w/2$	14.55	18	03
R/LH259.2020.13	20	20	135	-	33	20	$f_1+w/2$	18.55	18	03
R/LH259.2525.13	25	25	135	-	33	25	$f_1+w/2$	23.55	18	03

State R or L version

w see indexable inserts

Dimensions in mm

Further sizes upon request

For torque specification of the screw, please see Technical Instructions.

Spare Parts

Toolholder	Clamping Screw	TORX PLUS® Wrench
R/LH259...	6.23T25P	T25PQ



Indexable insert

259

Machining Brass

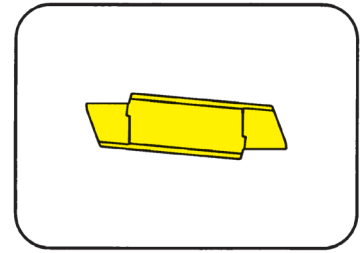

Depth of groove up to	.709"
Width of groove	.118 - .157"

precision ground

for Toolholder

Type H259

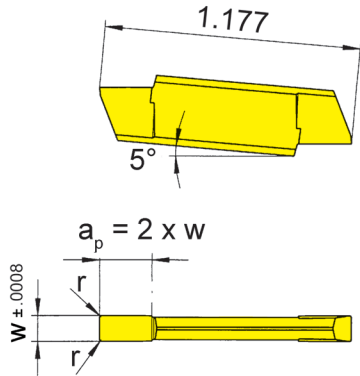

Indexability length ± .0006"

Usable length of secondary cutting edge $a_p = 2 \times w$ for machining brass (Ms58)

Part number	w	r	Size	MG12
259.0300.M1	.118	.006	03	▲
259.0300.M2	.118	.008	03	▲
259.0400.M1	.157	.006	03	▲
259.0400.M2	.157	.008	03	▲

▲ on stock Δ 4 weeks x upon request

- recommended
- alternative recommendation
- not suitable

- uncoated grades
- coated grades
- brazed/Cermet

Dimensions in inch

P	○
M	-
K	-
N	-
S	-
H	-

Carbide grades

Indexable inserts can be used in right and left hand toolholders.

H

231



Toolholder with Inserts

Width of groove .098 - .394"

I

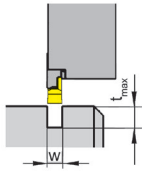

$w = .098 - .394"$
 (2.5 - 10 mm)
 $t_{max} = .433$ (11 mm)

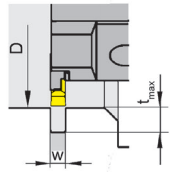

$w = .157 - .394"$ (4-10 mm)
 $t_{max} = .197 - .354"$ (5 - 9 mm)
 $D = 2.953 - 7.874"$
 (75 - 200 mm)

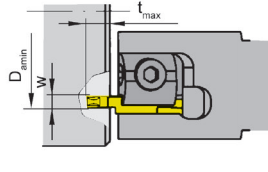

$w = .118 - .394"$
 (3 - 10 mm)
 $t_{max} = .315"$ (8 mm)
 $D_{a\ min} \geq 1.181"$ (30 mm)

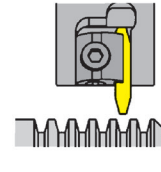

Metric trapezoidal thread

Toolholder
211/221/228

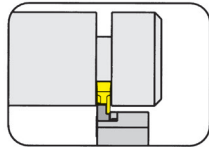

Page
13-14

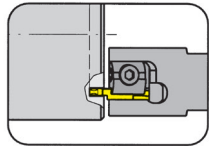

Page
111-112

Cartridge
208

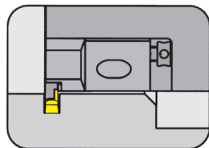

Page
15-16

Indexable Insert
231

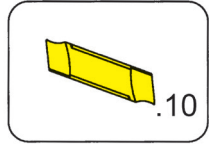

Page
17-18

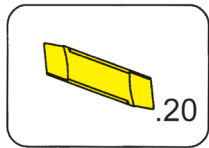

Page
19-110

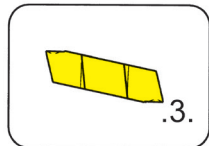

Page
113

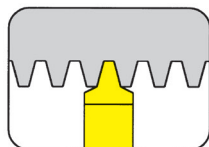

Page
114

Toolholder

211

Depth of groove up to
Clamping range

11 mm
2.5 - 5.0 mm

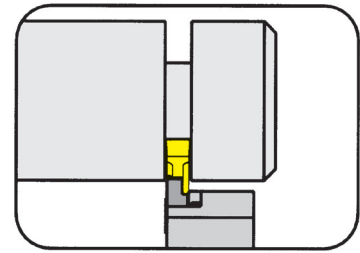

for Indexable insert

Type 231
N231

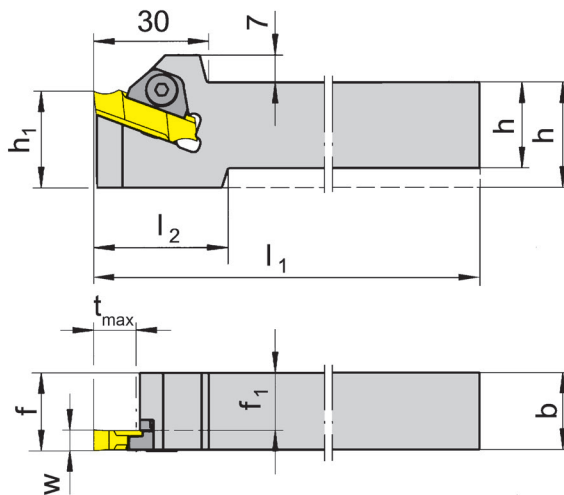

R = right hand version shown

L = left hand version

Part number	h	b	l ₁	l ₂	h ₁	f ₁	f	t _{max}	Size	Clamping range
R/L211.2020.02	20	20	125	35	25	17.5	f ₁ +w-a ₁	11	02	2.5 - 3.0
R/L211.2525.02	25	25	150	-	25	22.5	f ₁ +w-a ₁	11	02	2.5 - 3.0
R/L211.3232.02	32	32	170	-	32	29.5	f ₁ +w-a ₁	11	02	2.5 - 3.0
R/L211.2020.03	20	20	125	35	25	17.0	f ₁ +w-a ₁	11	03	3.0 - 4.0
R/L211.2525.03	25	25	150	-	25	22.0	f ₁ +w-a ₁	11	03	3.0 - 4.0
R/L211.3232.03	32	32	170	-	32	29.0	f ₁ +w-a ₁	11	03	3.0 - 4.0
R/L211.2020.04	20	20	125	35	25	16.0	f ₁ +w-a ₁	11	04	4.0 - 5.0
R/L211.2525.04	25	25	150	-	25	21.0	f ₁ +w-a ₁	11	04	4.0 - 5.0
R/L211.3232.04	32	32	170	-	32	28.0	f ₁ +w-a ₁	11	04	4.0 - 5.0

State R or L version

w, a₁ see indexable inserts

Dimensions in mm

Further sizes upon request

For torque specification of the screw, please see Technical Instructions.

Spare Parts

Toolholder	Allen wrench	Clamping element
R/L211...02	SW3,0 DIN911	2.16.2
R/L211...03	SW3,0 DIN911	2.16.3
R/L211...04	SW3,0 DIN911	2.16.7

Toolholder

211

Depth of groove up to
Clamping range

11 mm
5.0 - 10.0 mm

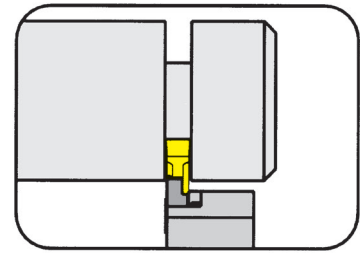

for Indexable insert

Type 231
N231

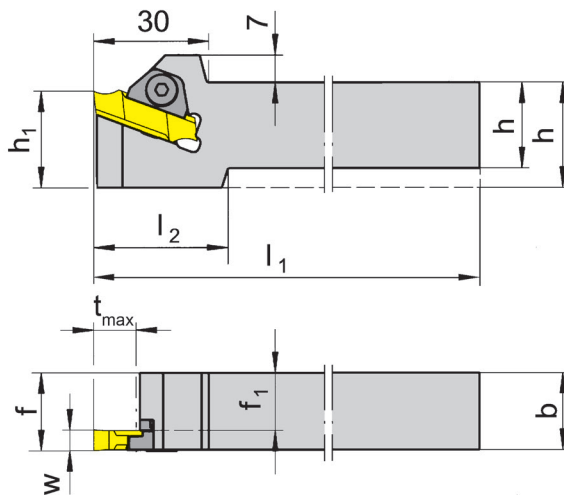

R = right hand version shown

L = left hand version

Part number	h	b	l_1	l_2	h_1	f_1	f	t_{max}	Size	Clamping range
R/L211.2020.05	20	20	125	35	25	15	f_1+w-a_1	11	05	5.0 - 6.5
R/L211.2525.05	25	25	150	-	25	20	f_1+w-a_1	11	05	5.0 - 6.5
R/L211.3232.05	32	32	170	-	32	27	f_1+w-a_1	11	05	5.0 - 6.5
R/L211.2020.07	20	20	125	35	25	13	f_1+w-a_1	11	07	6.5 - 8.5
R/L211.2525.07	25	25	150	-	25	18	f_1+w-a_1	11	07	6.5 - 8.5
R/L211.3232.07	32	32	170	-	32	25	f_1+w-a_1	11	07	6.5 - 8.5
R/L211.2020.09	20	20	125	35	25	11	f_1+w-a_1	11	09	8.5 - 10.0
R/L211.2525.09	25	25	150	-	25	16	f_1+w-a_1	11	09	8.5 - 10.0
R/L211.3232.09	32	32	170	-	32	23	f_1+w-a_1	11	09	8.5 - 10.0

State R or L version

w, a_1 see indexable inserts

Dimensions in mm

Further sizes upon request

For torque specification of the screw, please see Technical Instructions.

Spare Parts

Toolholder	Allen wrench	Clamping element
R/L211...	SW3,0 DIN911	2.16.7

Cartridge

208

Bore \varnothing from
Clamping range

75 mm
4.0 - 10.0 mm

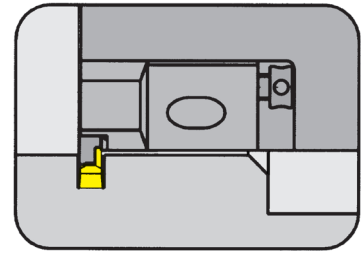

for Indexable insert

Type 231
N231

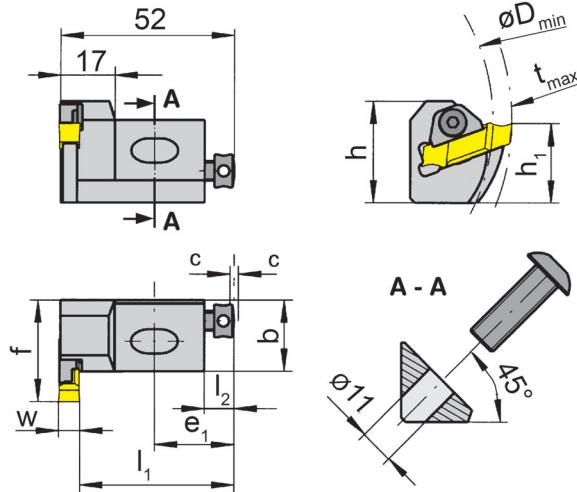

R = right hand version shown

L = left hand version

Depth of groove in relation to bore \varnothing

D_{min}	t_{max}
75	5.0
85	6.0
95	6.5
110	7.0
140	8.0
200	9.0

Part number	h	b	h_1	f	l_1	E_1	l_2	C	D_{min}	t_{max}	Size	Clamping range
R/L208.2520.04	32	20	25	32	47.8	25	9	2	75	5	04	4.0 - 5.0
R/L208.2520.05	32	20	25	32	46.8	25	9	2	75	5	05	5.0 - 6.5
R/L208.2520.07	32	20	25	32	44.8	25	9	2	75	5	07	6.5 - 8.5
R/L208.2520.09	32	20	25	32	42.8	25	9	2	75	5	09	8.5 - 10.0

State R or L version

Dimensions in mm

Further sizes upon request

For torque specification of the screw, please see Technical Instructions.

Spare Parts

Cartridge	Clamping Screw	Allen wrench	Screw	Clamping element
R/L208...	4.08.913	SW3,0 DIN911	6.12.020	2.16.7 K

Cartridge Seating Dimensions

208

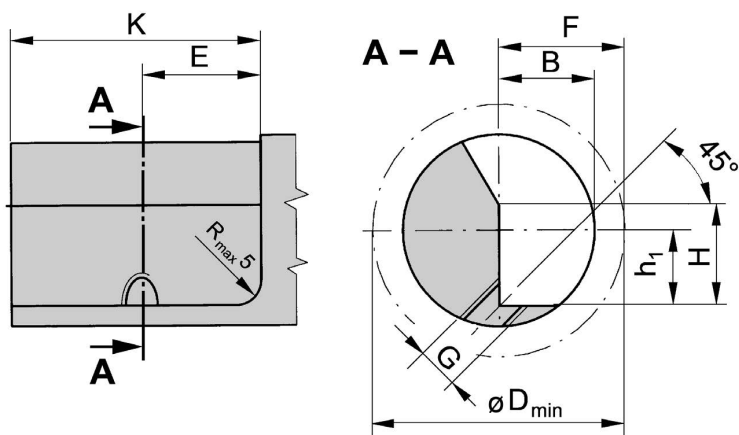
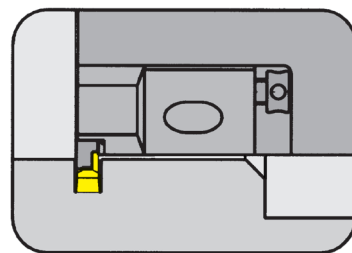

Part number	F	G	H	K	E	B	h_1	D_{min}	Fastening Screw
R/L208.2520...	32	M10	32	50	25	20	25	75	0.30.208

Dimensions in mm

Grooving (external)



Indexable insert

231

with round chip breaker

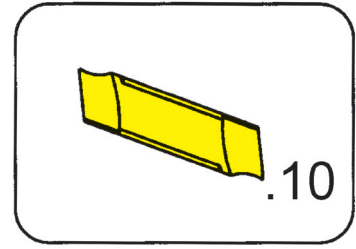

Depth of groove up to	.433"
Width of groove	.098 - .138"

precision ground

for Toolholder

Type 208
211

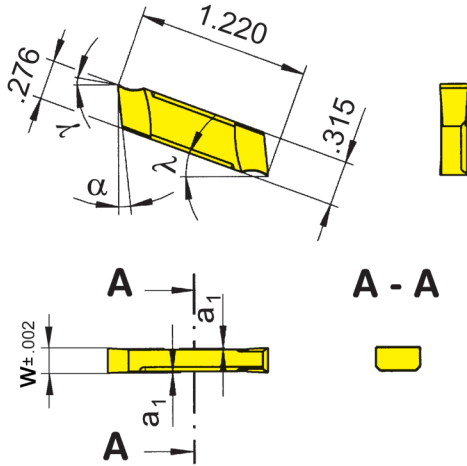

R = right hand version shown

L = left hand version

Indexability length ± .001"

Part number	w	a ₁	Size	K10	P20	TN32
R/L231.0250.10	.098	.008	02	x/x	▲/▲	▲/▲
R/L231.0300.10	.118	.008	03		▲/▲	
R/L231.0350.10	.138	.008	03	x/x	x/x	x/x

▲ on stock Δ 4 weeks x upon request

- recommended
- alternative recommendation
- not suitable

- uncoated grades
- coated grades
- brazed/Cermet

Dimensions in inch

	P	M	K	N	S	H
K10	●	○	●	●	○	-
P20	●	-	-	-	-	-
TN32	●	-	-	-	-	-

Carbide grades

State R or L version

Use right hand inserts in right hand toolholders and left hand inserts in left hand toolholders

Grooving (external and internal)



Indexable insert

231

with round chip breaker

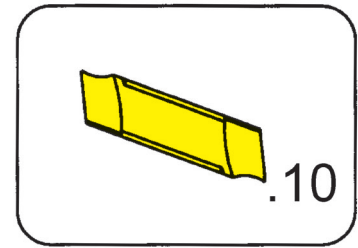

Depth of groove up to
Width of groove

.433"
.157 - .394"

precision ground

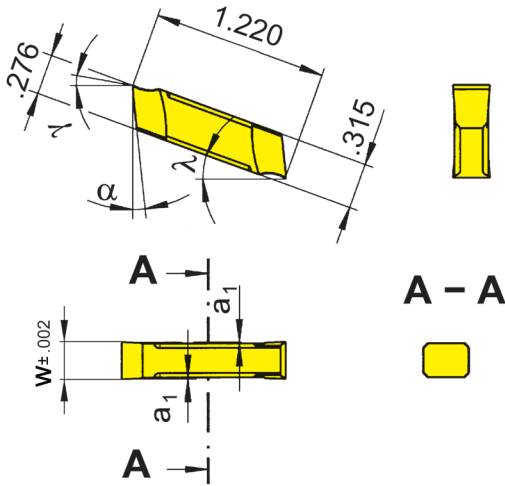

for Toolholder

Type 208
211

Indexability length ± .001"

Part number	w	a ₁	Size	Carbide grades			
				K10	P20	TC92	TN32
231.0400.10	.157	.008	04	▲	▲	▲	▲
231.0500.10	.197	.008	05		▲	▲	
231.0600.10	.236	.008	05	x	▲	▲	
231.0700.10	.276	.008	07		▲	▲	x
231.0800.10	.315	.008	07	▲	▲		▲
231.0900.10	.354	.008	09	x	x		
231.1000.10	.394	.008	09	▲	x	x	▲
				P	●	●	●
				M	○	-	-
				K	●	-	-
				N	●	-	-
				S	○	-	-
				H	-	-	-

▲ on stock Δ 4 weeks x upon request

● recommended

○ alternative recommendation

- not suitable

□ uncoated grades

■ coated grades

■ brazed/Cermet

Dimensions in inch

Carbide grades

Indexable inserts can be used in right and left hand toolholders.

Grooving (external)



Indexable insert

231

with straight chip breaker

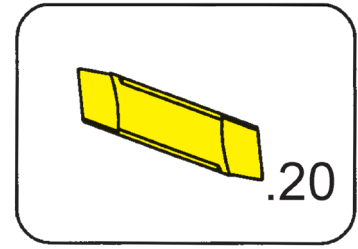

Depth of groove up to	.433"
Width of groove	.098 - .138"

precision ground

for Toolholder

Type 208
211

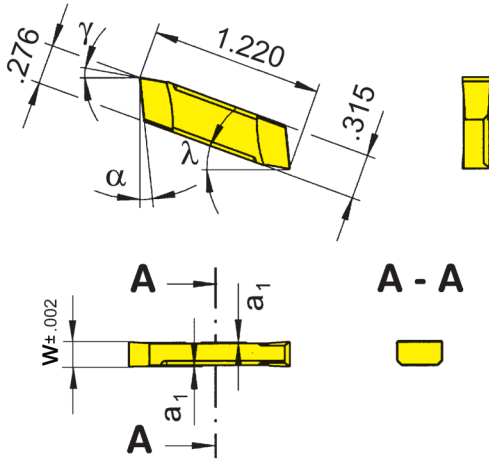

R = right hand version shown

L = left hand version

Indexability length ± .001"

Part number	w	a ₁	Size	TC92
R/L231.0250.20	.098	.008	02	x/x
R/L231.0300.20	.118	.008	03	x/x
R/L231.0350.20	.138	.008	03	x/x

▲ on stock Δ 4 weeks x upon request

- recommended
- alternative recommendation
- not suitable

- uncoated grades
- coated grades
- brazed/Cermet

Dimensions in inch

P	●
M	-
K	-
N	-
S	-
H	-

Carbide grades

State R or L version

Use right hand inserts in right hand toolholders and left hand inserts in left hand toolholders

Indexable inserts can be used in right and left hand toolholders.

Indexable insert

231

with straight chip breaker

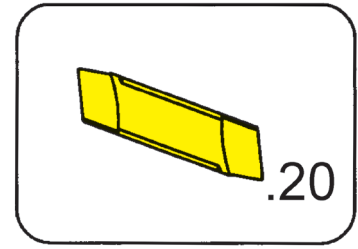

Depth of groove up to
Width of groove

.433"
.157 - .354"

precision ground

for Toolholder

Type 208
211

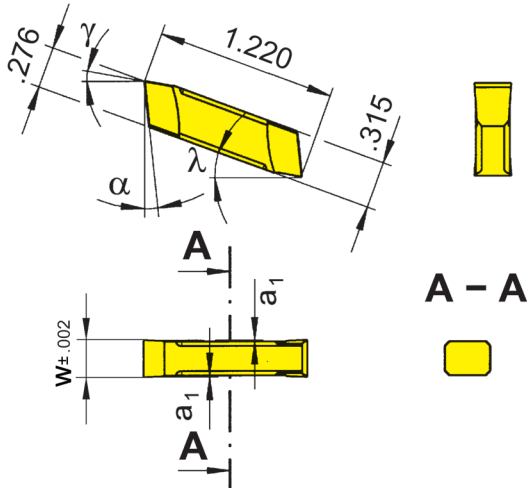

Indexability length $\pm .001''$

Part number	w	a ₁	Size	Carbide grades			
				K10	AS46	TC92	TF45
231.0400.20	.157	.008	04			Δ	x
231.0500.20	.197	.008	05			Δ	x
231.0600.20	.236	.008	05			Δ	x
231.0700.20	.276	.008	07			Δ	x
231.0800.20	.315	.008	07			Δ	x
231.0900.20	.354	.008	09	Δ	Δ	Δ	x
231.1000.20	.394	.008	09				

▲ on stock Δ 4 weeks x upon request

- recommended
- alternative recommendation
- not suitable

- uncoated grades
- coated grades
- brazed/Cermet

Dimensions in inch
State R or L version

Indexable inserts can be used in right and left hand toolholders.

	P	M	K	N	S	H
●	●	●	●	●	●	●
○	○	○	○	○	○	○
-	-	-	-	-	-	-
-	-	-	-	-	-	-
-	-	-	-	-	-	-

Carbide grades

Toolholder

221

from outer groove \varnothing
Depth of groove up to
Clamping range

40 mm
8 mm
3 - 10 mm

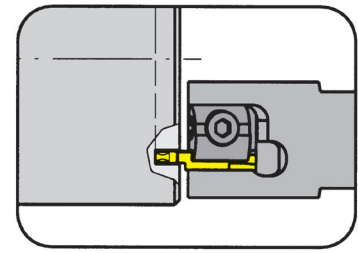

for Indexable insert

Type 231
N231

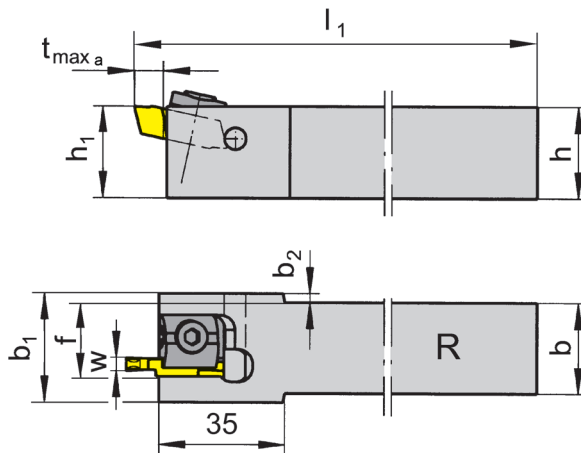

R = right hand version shown

L = left hand version

Part number	h	b	l_1	h_1	b_1	f	$t_{max a}$	b_2	$D_{a min}$	Size	Clamping range
R/L221.2020.04	20	20	125	20	28	17.9	8	4.0	40	04	3.0 - 4.0
R/L221.2525.04	25	25	150	25	28	20.4	8	1.5	40	04	3.0 - 4.0
R/L221.2020.05	20	20	125	20	30	18.9	8	5.0	40	05	4.1 - 6.0
R/L221.2525.05	25	25	150	25	30	21.4	8	2.5	40	05	4.1 - 6.0
R/L221.2020.07	20	20	125	20	32	19.9	8	6.0	40	07	6.1 - 8.0
R/L221.2525.07	25	25	150	25	32	22.4	8	3.5	40	07	6.1 - 8.0
R/L221.2020.09	20	20	125	20	34	20.9	8	7.0	40	09	8.1 - 10.0
R/L221.2525.09	25	25	150	25	34	23.4	8	4.5	40	09	8.1 - 10.0

State R or L version

w see indexable inserts

Dimensions in mm

Further sizes upon request

This toolholder can be used from $D_{a min} \geq 40$ mm depending on grooving depth.

For torque specification of the screw, please see Technical Instructions.

Spare Parts

Toolholder	Stop Pin	Clamping element	TORX PLUS® Wrench
R/L221...	3.6.28	01.60.12	T20PQ

Toolholder

228

from outer groove \varnothing
Depth of groove up to
Clamping range

40 mm
8 mm
3 - 10 mm

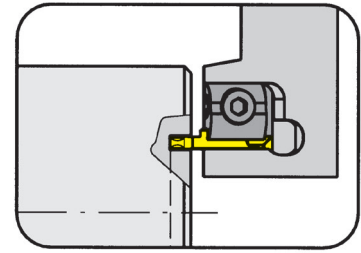

for Indexable insert

Type 231
N231

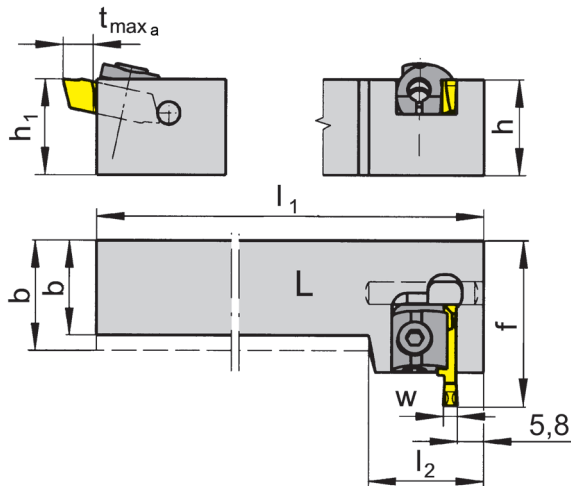

L = left hand version shown

R = right hand version

Part number	h	b	h ₁	f	t _{max a}	D _{a min}	l ₁	l ₂	Size	Clamping range
R/L228.2020.04	20	20	20	38.5	8	40	125	35.5	04	3.0 - 4.0
R/L228.2525.04	25	25	25	38.5	8	40	150	35.5	04	3.0 - 4.0
R/L228.2020.05	20	20	20	38.5	8	40	125	35.5	05	4.1 - 6.0
R/L228.2525.05	25	25	25	38.5	8	40	150	35.5	05	4.1 - 6.0
R/L228.2020.07	20	20	20	38.5	8	40	125	35.5	07	6.1 - 8.0
R/L228.2525.07	25	25	25	38.5	8	40	150	35.5	07	6.1 - 8.0
R/L228.2020.09	20	20	20	38.5	8	40	125	35.5	09	8.1 - 10.0
R/L228.2525.09	25	25	25	38.5	8	40	150	35.5	09	8.1 - 10.0

State R or L version

w see indexable inserts

Dimensions in mm

Further sizes upon request

This toolholder can be used from $D_{a min} \geq 40$ mm depending on grooving depth.

For torque specification of the screw, please see Technical Instructions.

Spare Parts

Toolholder	Stop Pin	Clamping element	TORX PLUS® Wrench
R/L228...	3.6.28	01.60.12	T20PQ

Indexable insert

231

with chip former

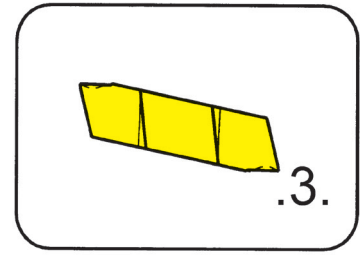

from outer groove \varnothing 1.575"
 Depth of groove up to .315"
 Width of groove .118 - .394"

precision sintered

for Toolholder

Type 221
 228

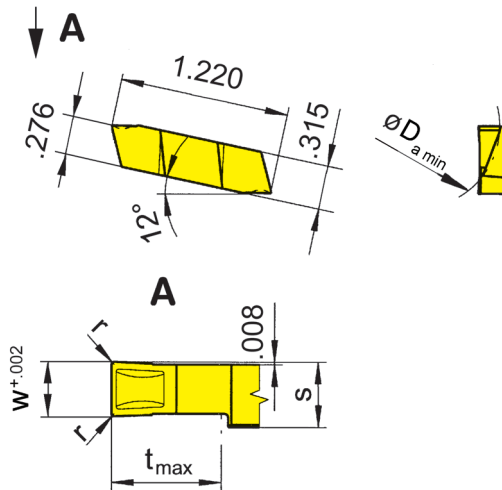

Indexability length $\pm .001''$

Part number	w	r	t _{max}	s	D _{a min}	Size	TN35
R/L231.4030.32	.118	.008	.315	.150	1.575	04	▲▲
R/L231.4040.32	.157	.008	.315	.150	1.575	04	▲▲
R/L231.4050.34	.197	.016	.315	.228	1.575	05	▲▲
N231.4060.34	.236	.016	.315	.228	1.575	05	▲
N231.4070.36	.276	.024	.315	.307	1.575	07	▲
N231.4080.36	.315	.024	.315	.307	1.575	07	▲
N231.4090.38	.354	.031	.315	.386	1.575	09	▲
N231.4100.38	.394	.031	.315	.386	1.575	09	▲

▲ on stock Δ 4 weeks x upon request
 ● recommended
 ○ alternative recommendation
 - not suitable
 □ uncoated grades
 ■ coated grades
 ■ brazed/Cermet

P	●
M	●
K	●
N	●
S	●
H	-

Dimensions in inch

Carbide grades

State R, L or N version

Outer- \varnothing of groove < 1.575" upon request.

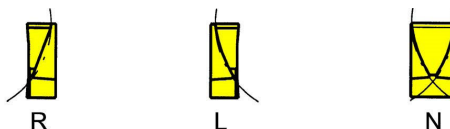

R = Right Hand Version L = Left Hand Version N = Right and Left Hand Version

Threading (external) Full profile



Indexable insert

231

Pitch	7 - 12mm
-------	----------

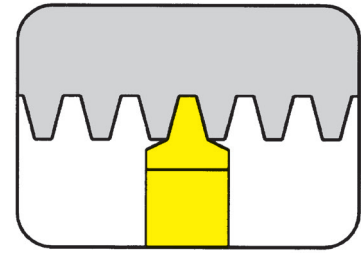

precision ground

for Toolholder

Type 221
228

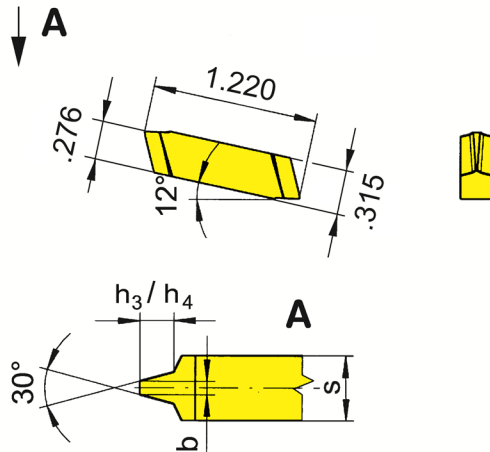

Metric ISO trapezoidal
thread DIN 103

Part number	P	h_1	b	s	Size	TN35
231.4070.02	.276	.157	.090	.228	05	▲
231.4580.02	.315	.177	.105	.228	05	▲
231.5090.02	.354	.197	.119	.307	07	▲
231.5500.02	.394	.217	.133	.307	07	▲
231.6020.02	.472	.256	.162	.386	09	▲

▲ on stock Δ 4 weeks x upon request

● recommended

○ alternative recommendation

- not suitable

□ uncoated grades

■ coated grades

■ brazed/Cermet

Dimensions in inch

P	•
M	•
K	•
N	•
S	•
H	-

Carbide grades

No shims necessary. All HORN thread profiles are manufactured with **fully ground radial clearance**.

262



Toolholder with Inserts

Width of groove .001 - .236"

J

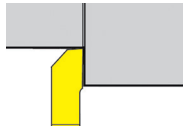

Grooving and Side Turning

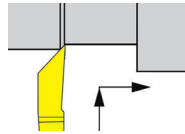

Copy Turning (Finishing)

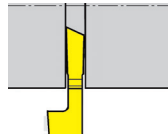

Parting off

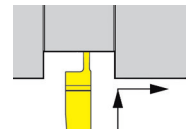

Grooving and Back Turning

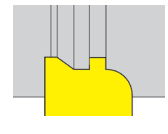

Semi-finished Insert

Toolholder
262

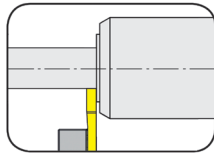

Page
J3

Indexable Insert
S262

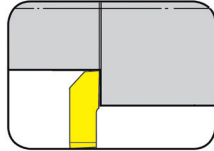

Page
J4

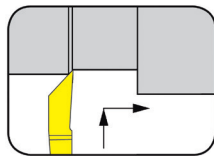

Page
J5

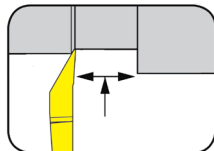

Page
J6

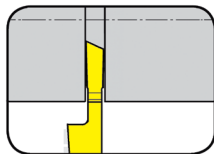

Page
J7

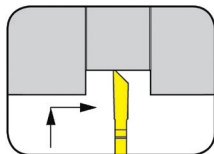

Page
J8-J9

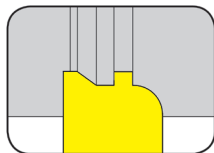

Page
J10

J

Toolholder

H262

Depth of groove up to
Width of groove up to

7.5 mm
0.025 - 6 mm

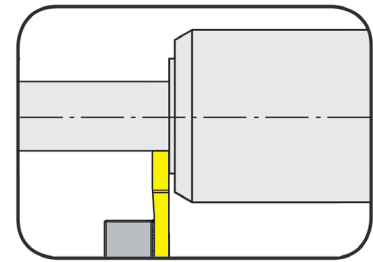

for Indexable insert

Type LS262

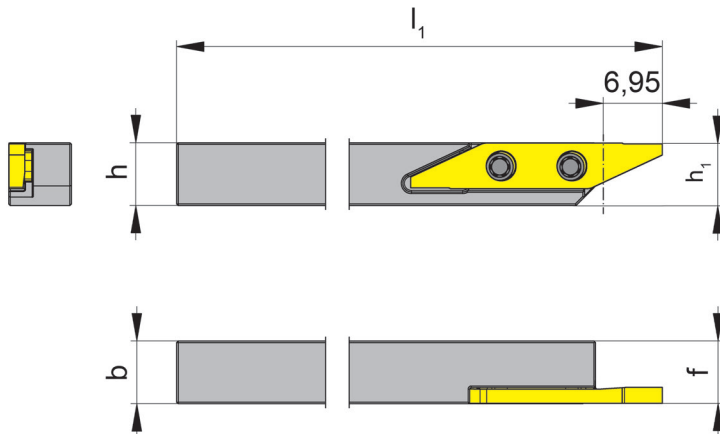

L = left hand version shown

Part number	h	b	l_1	h_1	f	t_{max}	Size
LH262.0606.04	6	6	100	5.83	5.95	7.5	04
LH262.0707.04	7	7	100	6.83	6.95	7.5	04
LH262.0808.04	8	8	100	7.83	7.95	7.5	04
LH262.0808.2.04	8	8	150	7.83	7.95	7.5	04
LH262.1010.04	10	10	100	9.83	9.95	7.5	04

Further sizes upon request

Dimensions in mm

Torque specification of the screw 030.2557.T8P = 1,0 Nm.

Spare Parts

Toolholder	Clamping Screw	TORX PLUS® Wrench
LH262...	030.2557.T8P	T8PL

Indexable insert

S262

precision ground

Width of groove	.002 - .079"
-----------------	--------------

precision ground

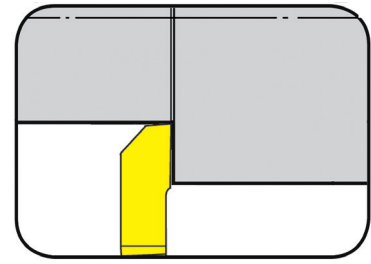

for Toolholder

Type LH262

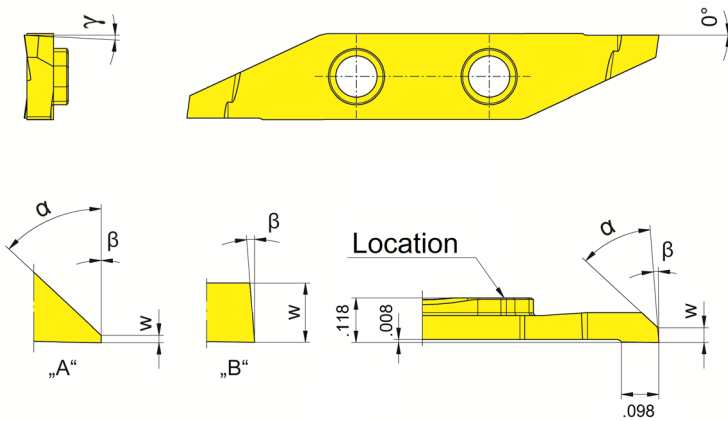

L = left hand version shown

Part number	w	γ	α	Form	β	EG35
LS262.0547.04	.002	0°	47°	A	0°	▲
LS262.2047.03	.079	3°	0°	B	4°	Δ

▲ on stock Δ 4 weeks x upon request

- recommended
- alternative recommendation
- not suitable

- uncoated grades
- coated grades
- brazed/Cermet

Dimensions in inch

P	●
M	●
K	○
N	-
S	-
H	-

Carbide grades



Indexable insert

S262

precision ground

Width of groove	.001"
Depth of cut up to	.071"

precision ground

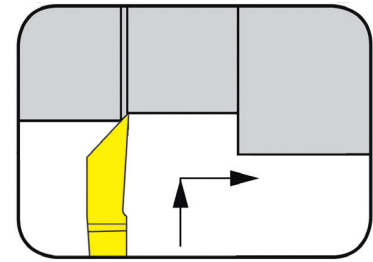

for Toolholder

Type LH262

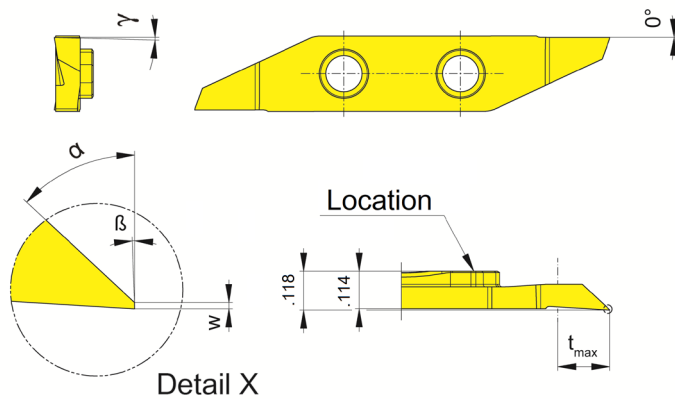

L = left hand version shown

Part number	w	t _{max}	γ	α	β	EG35
LS262.0247.04	.001	.071	1.5°	47°	2°	▲
						P ●
						M ●
						K ○
						N -
						S -
						H -

- ▲ on stock Δ 4 weeks x upon request
- recommended
- alternative recommendation
- not suitable

- uncoated grades
- coated grades
- brazed/Cermet

Dimensions in inch

Carbide grades



Indexable insert

S262

precision ground

Width of groove
Depth of cut up to

.001 - .004"
.118"

precision ground

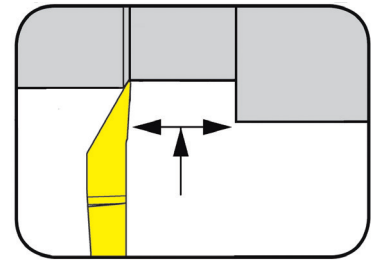

for Toolholder

Type LH262

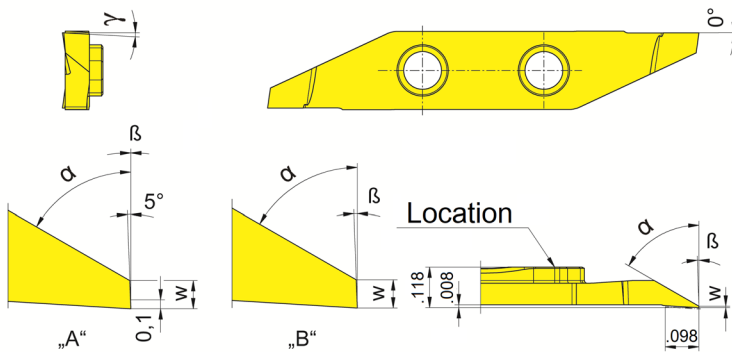

L = left hand version shown

Part number	w	t _{max}	γ	α	Form	β	EG35
LS262.0147.04	.001	.071	0°	47°	A	0°	▲
LS262.0160.03	.004	.118	3°	60°	B	2°	▲

P	•
M	•
K	○
N	-
S	-
H	-

Carbide grades

- ▲ on stock Δ 4 weeks x upon request
- recommended
- alternative recommendation
- not suitable
- uncoated grades
- coated grades
- brazed/Cermet

Dimensions in inch

Indexable insert

S262

precision ground

Width of groove
Depth of cut up to

.028 - .039"
.197"

precision ground

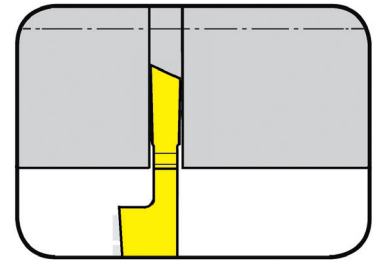

for Toolholder

Type LH262

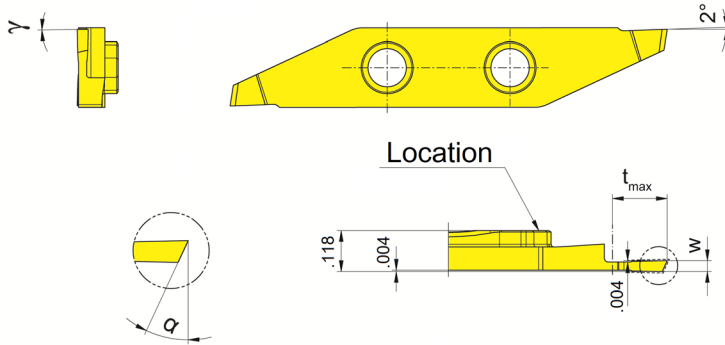

L = left hand version shown

Part number	w	t _{max}	γ	α	EG35
LS262.2007.02	.028	.079	0°	20°	▲
LS262.2508.03	.031	.118	0°	25°	▲
LS262.2509.04	.035	.157	0°	25°	▲
LS262.2510.05	.039	.197	0°	25°	▲

▲ on stock Δ 4 weeks x upon request

● recommended
○ alternative recommendation
- not suitable

□ uncoated grades
■ coated grades
■ brazed/Cermet

Dimensions in inch

P	●
M	●
K	○
N	-
S	-
H	-

Carbide grades

J

Indexable insert

S262

precision ground

Width of groove
Depth of cut up to

.031 - .071"
.236"

precision ground

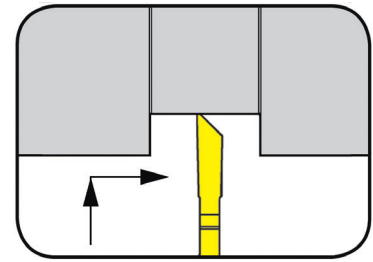

for Toolholder

Type LH262

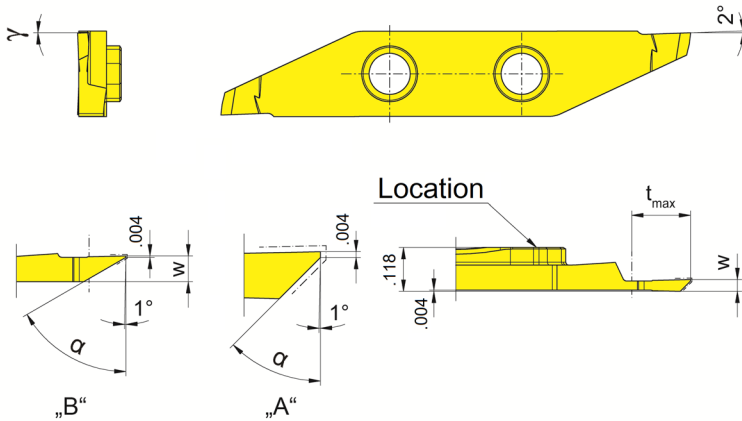

L = left hand version shown

Part number	w	t _{max}	γ	α	Form	EG35
LS262.4508.04	.031	.079	0°	45°	A	▲
LS262.4509.04	.035	.157	0°	45°	A	▲
LS262.4510.06	.039	.236	0°	45°	A	▲
LS262.4512.06	.047	.236	0°	45°	A	▲
LS262.6015.02	.071	.098	0°	60°	B	▲
LS262.7010.02	.047	.098	0°	70°	B	▲

▲ on stock Δ 4 weeks x upon request

● recommended
○ alternative recommendation
- not suitable

□ uncoated grades

■ coated grades

■ brazed/Cermet

Dimensions in inch

P	●
M	●
K	○
N	-
S	-
H	-

Carbide grades

Indexable insert

S262

precision ground

Width of groove	.020 - .079"
Depth of cut up to	.118"

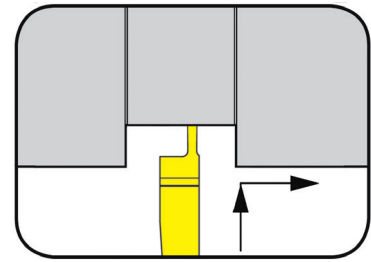

precision ground

for Toolholder

Type LH262

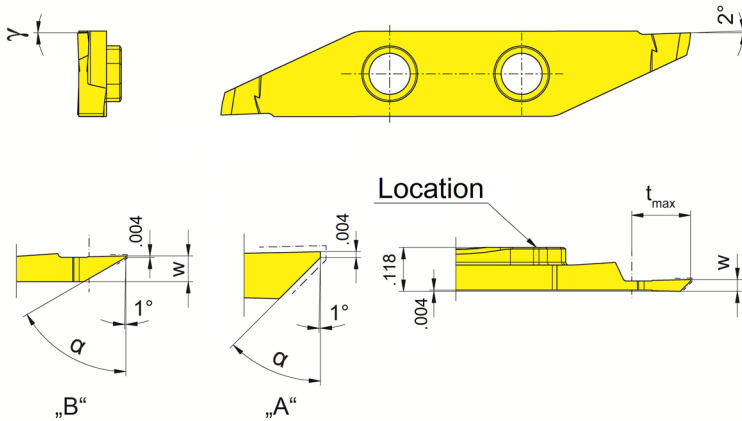

L = left hand version shown

Part number	w	t _{max}	γ	α	EG35
LS262.0005.01	.020	.039	0°	90°	▲
LS262.0010.02	.039	.079	0°	90°	▲
LS262.0012.02	.047	.079	0°	90°	▲
LS262.0015.03	.059	.118	0°	90°	▲
LS262.0020.03	.079	.118	0°	90°	▲

▲ on stock Δ 4 weeks x upon request

● recommended

o alternative recommendation

- not suitable

□ uncoated grades

■ coated grades

■ brazed/Cermet

Dimensions in inch

P	●
M	●
K	○
N	-
S	-
H	-

Carbide grades



Indexable insert

S262

Width of groove	.079"
Depth of cut up to	.295"

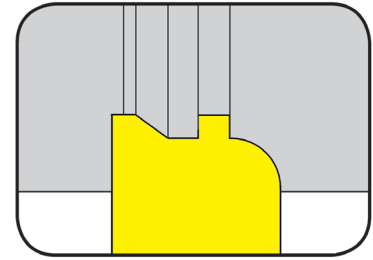

for Toolholder

Type LH262

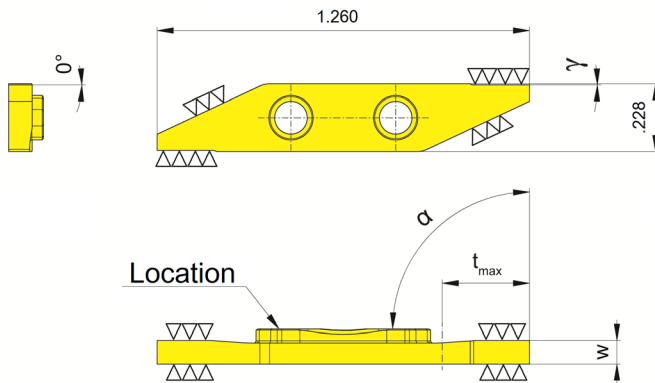

L = left hand version shown

Part number	w	t _{max}	γ	α	MG12
LS262.8520.06	.079	.295	0°	90°	▲
					P ○
					M -
					K -
					N -
					S -
					H -

▲ on stock Δ 4 weeks x upon request
 ● recommended
 ○ alternative recommendation
 - not suitable

■ uncoated grades
 ■ coated grades
 ■ brazed/Cermet

Dimensions in inch

Carbide grades



264

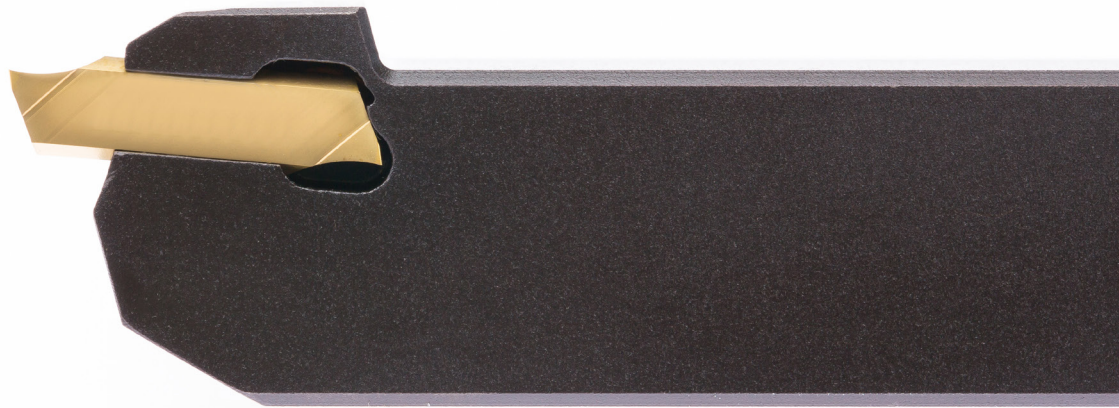

Toolholder with Inserts

Width of groove .059 - .118"

K

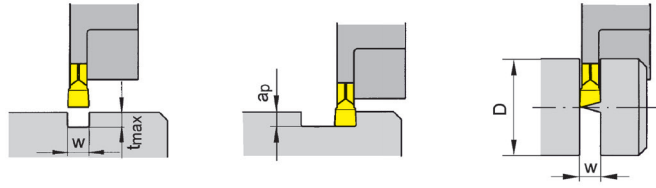

$w = .059 - .118''$ (1.5 - 3 mm)
 $t_{max} = .630''$ (16 mm)

$w = .059''$ (1.5 mm)
 $a_p = .089''$ (2.25 mm)

$w = .059 - .118''$ (1.5 - 3 mm)
 $D = .787 - 1.260''$ (20 - 32 mm)

Toolholder
HU264/H264

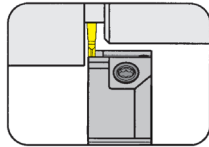

Page
K3-K7

Indexable Insert
264

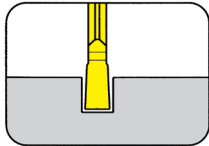

Page
K8, K10, K12

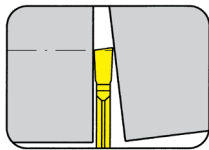

Page
K9, K11

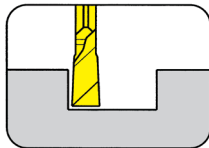

Page
K13-K14

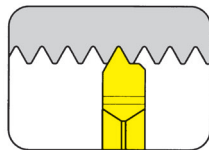

Page
K15

K

Grooving and Parting Off



Toolholder

HU264

with screwed clamping

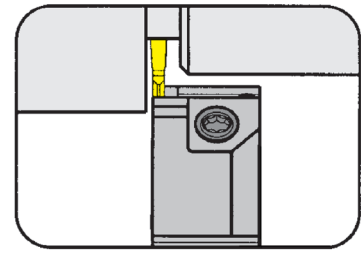

Depth of groove up to
Width of groove

.157"
.079"

for Indexable insert

Type 264
S264

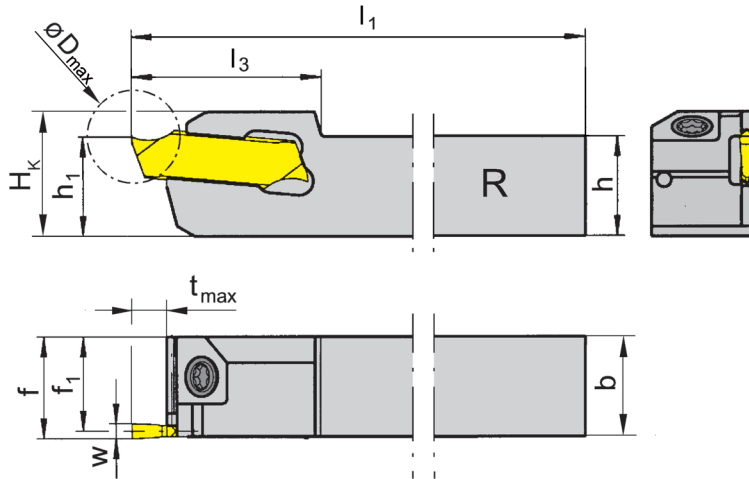

R = right hand version shown

L = left hand version

Part number	h	b	l ₁	l ₃	h ₁	f ₁	f	t _{max}	D _{max}	H _k	Size
LHU264.0750.01	.750	.750	4.724	.689	.750	.720	.750	.157	1.260	.848	01

State R or L version

w see inserts

Dimensions in inch

Further sizes upon request

For torque specification of the screw, please see Technical Instructions.

Spare Parts

Toolholder	Clamping Screw	TORX PLUS® Wrench
LHU264.0750.01	3.5.12T10EP	T10PL

Toolholder

H264

with screwed clamping

Depth of groove up to
Width of groove

16 mm
1.5 - 2 mm

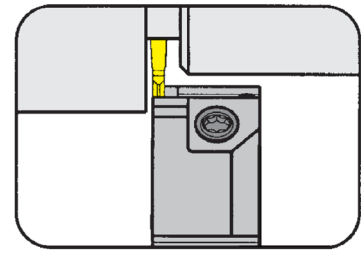

for Indexable insert

Type 264
S264

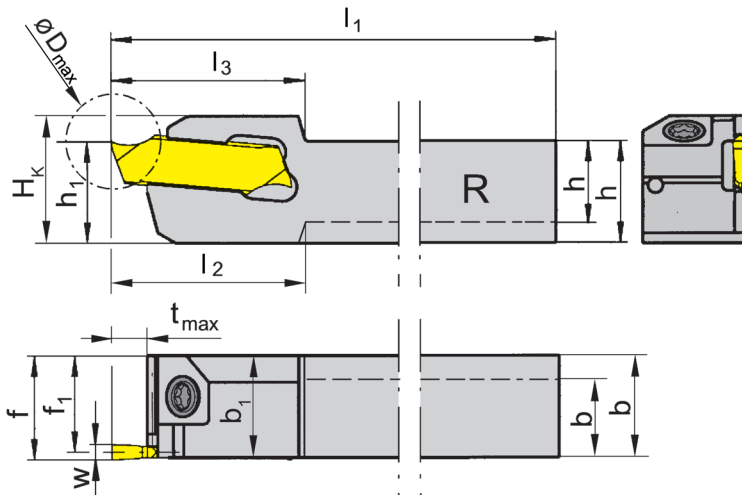

R = right hand version shown

L = left hand version

Part number	h	b	l ₁	l ₂	l ₃	h ₁	b ₁	f ₁	f	t _{max}	D _{max}	H _K	Size
R/LH264.0808.01	8	10	120	17.5	17.5	8	10	9.25	10	4	22	12.5	01
R/LH264.1010.01	10	10	120	-	17.5	10	-	9.25	10	4	22	12.5	01
R/LH264.1212.01	12	12	120	-	17.5	12	-	11.25	12	4	22	14.5	01
R/LH264.1616.01	16	16	120	-	17.5	16	-	15.25	16	4	32	18.5	01
R/LH264.1010.11	10	10	120	-	19.0	10	-	9.25	10	10	20	12.5	01
R/LH264.1212.11	12	12	120	-	19.0	12	-	11.25	12	10	20	14.5	01
R/LH264.1616.11	16	16	120	-	19.0	16	-	15.25	16	10	32	18.5	01
R/LH264.1212.21	12	12	120	-	22.0	12	-	11.25	12	13	26	15.5	01
R/LH264.1616.21	16	16	120	-	22.0	16	-	15.25	16	13	32	19.5	01
R/LH264.1010.02	10	10	120	-	17.5	10	-	9.00	10	4	32	12.5	02
R/LH264.1212.02	12	12	120	-	17.5	12	-	11.00	12	4	32	14.5	02
R/LH264.1616.02	16	16	120	-	17.5	16	-	15.00	16	4	32	18.5	02
R/LH264.1010.12	10	10	120	-	19.0	10	-	9.00	10	10	32	12.5	02
R/LH264.1212.12	12	12	120	-	19.0	12	-	11.00	12	10	32	14.5	02
R/LH264.1616.12	16	16	120	-	19.0	16	-	15.00	16	10	32	18.5	02
R/LH264.1212.22	12	12	120	-	25.0	12	-	11.00	12	16	32	14.5	02
R/LH264.1616.22	16	16	120	-	25.0	16	-	15.00	16	16	32	19.5	02

State R or L version

w see inserts

Dimensions in mm

Further sizes upon request

For torque specification of the screw, please see Technical Instructions.

Spare Parts

Toolholder	Clamping Screw	TORX PLUS® Wrench
R/LH264...	3.5.12T10EP	T10PL

Toolholder

H264

with screwed clamping

Depth of groove up to
Width of groove

16 mm
2.5 mm

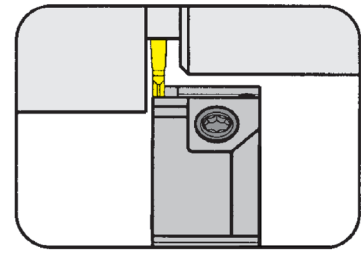

for Indexable insert

Type 264
S264

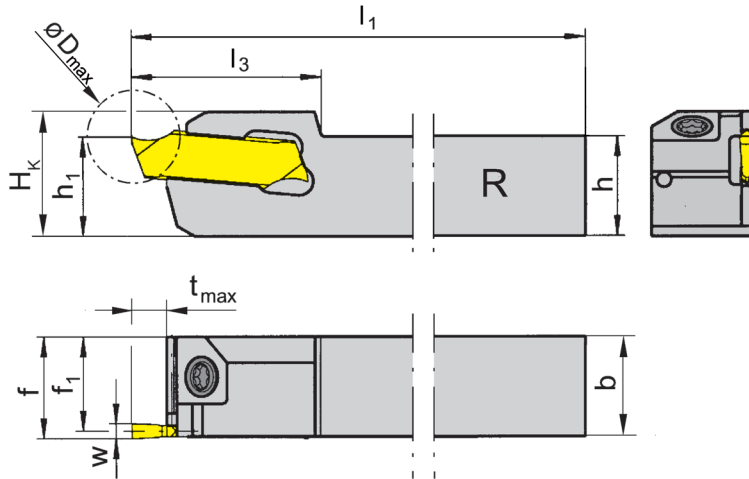

R = right hand version shown

L = left hand version

Part number	h	b	l ₁	l ₃	h ₁	f ₁	f	t _{max}	D _{max}	H _k	Size
R/LH264.1212.03	12	12	120	17.5	12	10.75	12	4	32	14.5	03
R/LH264.1616.03	16	16	120	17.5	16	14.75	16	4	32	18.5	03
R/LH264.1212.13	12	12	120	19.0	12	10.75	12	10	32	14.5	03
R/LH264.1616.13	16	16	120	19.0	16	14.75	16	10	32	18.5	03
R/LH264.1212.23	12	12	120	25.0	12	10.75	12	16	32	14.5	03
R/LH264.1616.23	16	16	120	25.0	16	14.75	16	16	32	18.5	03

State R or L version

w see inserts

Dimensions in mm

Further sizes upon request

For torque specification of the screw, please see Technical Instructions.

Spare Parts

Toolholder	Clamping Screw	TORX PLUS® Wrench
R/LH264...	3.5.12T10EP	T10PL

Toolholder

H264

with screwed clamping

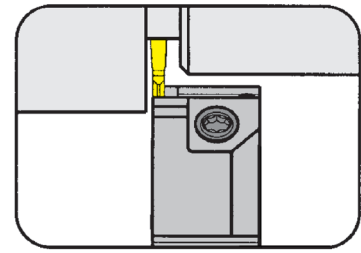

Depth of groove up to
Width of groove

16 mm
3 mm

for Indexable insert

Type 264
S264

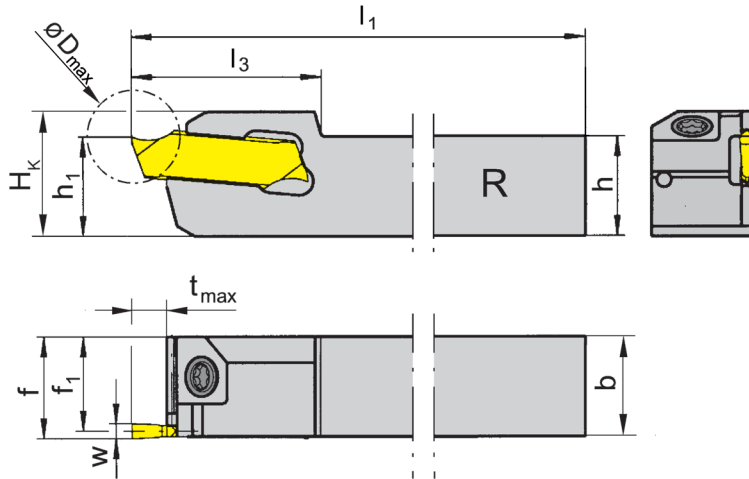

R = right hand version shown

L = left hand version

Part number	h	b	l_1	l_3	h_1	f_1	f	t_{max}	D_{max}	H_K	Size
R/LH264.1212.04	12	12	120	17.5	12	10.5	12	5	32	15	04
R/LH264.1616.04	16	16	120	17.5	16	14.5	16	5	32	19	04
R/LH264.1212.14	12	12	120	19.0	12	10.5	12	10	32	15	04
R/LH264.1616.14	16	16	120	19.0	16	14.5	16	10	32	19	04
R/LH264.1212.24	12	12	120	25.0	12	10.5	12	16	32	15	04
R/LH264.1616.24	16	16	120	25.0	16	14.5	16	16	32	19	04

State R or L version

w see inserts

Dimensions in mm

Further sizes upon request

For torque specification of the screw, please see Technical Instructions.

K

Spare Parts

Toolholder	Clamping Screw	TORX PLUS® Wrench
R/LH264...	3.5.12T10EP	T10PL

K6

Call Us Toll Free (888) 818-4676

Toolholder

H264

with self clamping

Depth of groove up to
Width of groove

10 mm
1.5 - 3 mm

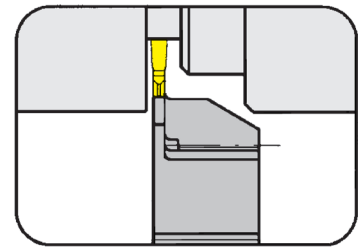

for Indexable insert

Type 264
S264

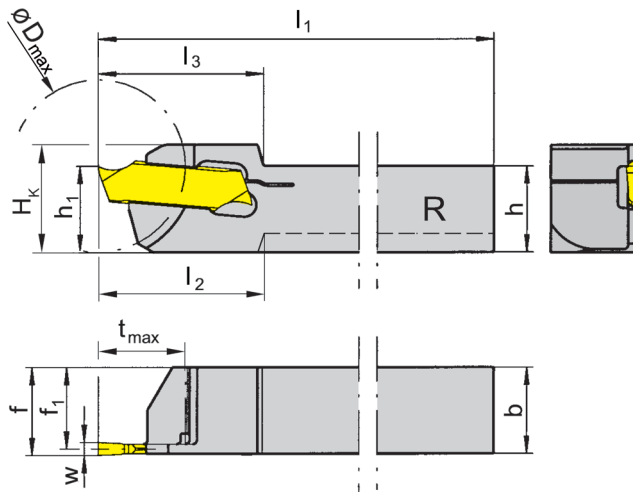

R = right hand version shown

L = left hand version

Part number	h	b	l ₁	l ₂	l ₃	h ₁	f ₁	f	t _{max}	D _{max}	H _K	Size
R/LH264.0808.51	8	8	120	18	18	10	7.25	8	7	20	12.5	01
R/LH264.1010.61	10	10	120	-	19	10	9.25	10	10	20	12.5	01
R/LH264.1010.62	10	10	120	-	19	10	9.00	10	10	20	12.5	02
R/LH264.1212.62	12	12	120	-	19	12	11.00	12	10	20	14.5	02
R/LH264.1212.63	12	12	120	-	19	12	10.75	12	10	32	14.5	03
R/LH264.1212.64	12	12	120	-	19	12	10.50	12	10	32	14.5	04

State R or L version

w see inserts

Dimensions in mm

Further sizes upon request

Note:

Wrench **P39L** is not combined with blade - separate order required!

Spare Parts

Toolholder	Wrench
R/LH264...51/.61/.62/.63	P39L

Indexable insert

264

Depth of groove up to .630"
Width of groove .059 - .118"

precision ground

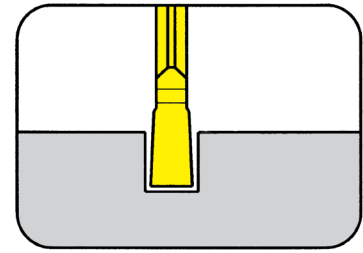

for Toolholder

Type H264

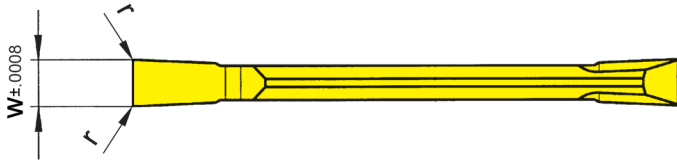
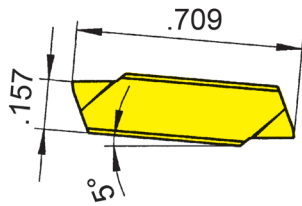

Indexability length ± .0006"

Part number	w	r	Size	MG12	TH35	TN35
264.0150.M0	.059	.002	01	▲	▲	▲
264.0200.M0	.079	.002	02	▲	▲	▲
264.0250.M0	.098	.004	03	▲	▲	▲
264.0300.M0	.118	.004	04	▲	▲	▲
				P	○	●
				M	-	●
				K	-	●
				N	-	●
				S	-	●
				H	-	-

▲ on stock Δ 4 weeks x upon request
 ● recommended
 ○ alternative recommendation
 - not suitable
 □ uncoated grades
 ■ coated grades
 ■ brazed/Cermet

Dimensions in inch

Carbide grades

Indexable inserts can be used in right and left hand toolholders.

K

Indexable insert

264

Depth of groove up to .630"
Width of groove .059 - .118"

precision ground

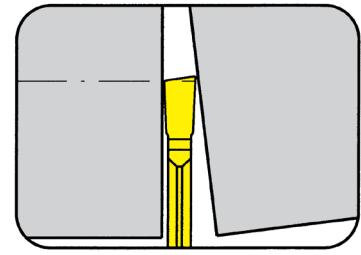

for Toolholder

Type H264

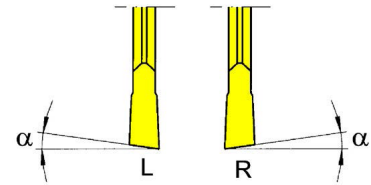
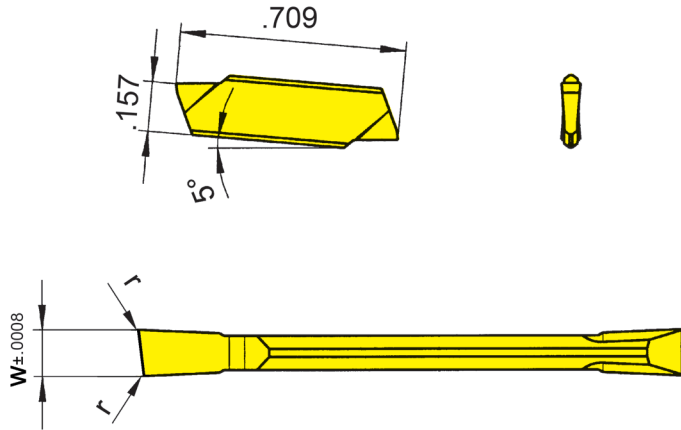

Indexability length ± .0006"

R = right hand version shown

L = left hand version

Part number	w	r	α	Size	MG12	TH35	TN35
R/L264.0815.M0	.059	.002	8°	01	▲/▲	▲/▲	▲/▲
R/L264.1515.M0	.059	.002	15°	01	▲/▲	▲/▲	▲/▲
R/L264.0820.M0	.079	.002	8°	02	▲/▲	▲/▲	▲/▲
R/L264.1520.M0	.079	.002	15°	02	Δ/Δ	▲/▲	▲/▲
R/L264.0825.M0	.098	.004	8°	03	x/x	▲/▲	▲/▲
R/L264.1525.M0	.098	.004	15°	03	Δ/Δ	▲/x	▲/x
R/L264.0830.M0	.118	.004	8°	04	x/x	▲/▲	▲/▲
R/L264.1530.M0	.118	.004	15°	04	x/Δ	▲/▲	▲/▲

- ▲ on stock Δ 4 weeks x upon request
- recommended
- alternative recommendation
- not suitable
- uncoated grades
- coated grades
- brazed/Cermet

Dimensions in inch

State R or L version

Indexable inserts can be used in right and left hand toolholders.

P	○	●	●
M	-	●	●
K	-	●	●
N	-	●	●
S	-	●	●
H	-	-	-

Carbide grades

K

Indexable insert

264

Depth of groove up to
Width of groove

.630"
.059 - .118"

precision ground

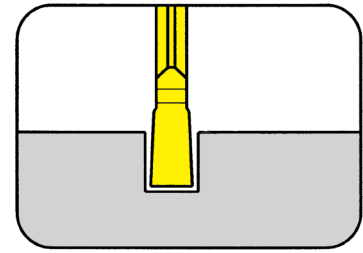

for Toolholder

Type H264

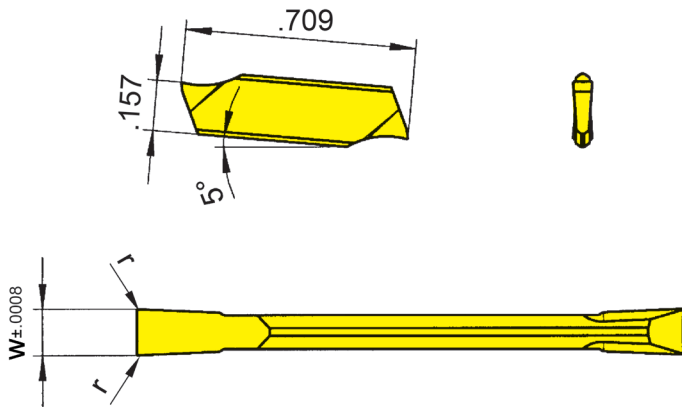

Indexability length ±
.0006"

Part number	w	r	Size	MG12	TH35	TI25	TN35
264.0150.10	.059	.002	01	▲	▲	x	▲
264.0200.10	.079	.002	02	▲	▲	x	▲
264.0250.10	.098	.004	03	△	▲	x	▲
264.0300.10	.118	.004	04	▲	▲	x	▲
				P	o	•	•
				M	-	•	•
				K	-	•	•
				N	-	•	•
				S	-	•	•
				H	-	-	-

Carbide grades

▲ on stock Δ 4 weeks x upon request
 ● recommended
 ○ alternative recommendation
 - not suitable
 □ uncoated grades
 ■ coated grades
 ■ brazed/Cermet
 Dimensions in inch

Indexable inserts can be used in right and left hand toolholders.

K

Indexable insert

264

Depth of groove up to
Width of groove

.630"
.059 - .118"

precision ground

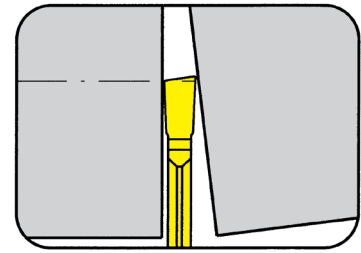

for Toolholder

Type H264

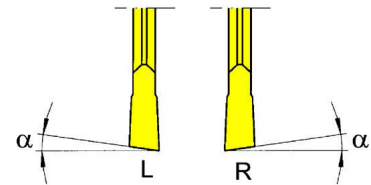
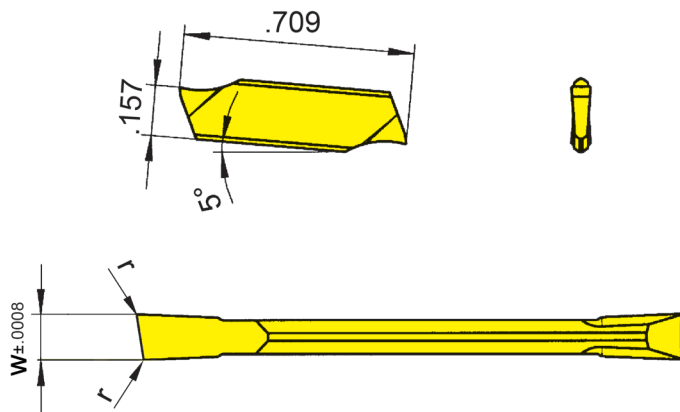

Indexability length ±
.0006"

R = right hand version shown

L = left hand version

Part number	w	r	α	Size	MG12	TH35	T125	TN35
					MG12	TH35	T125	TN35
R/L264.0815.10	.059	.002	8°	01	Δ/▲	▲/▲	x/x	▲/▲
R/L264.1515.10	.059	.002	15°	01	▲/▲	▲/▲		▲/▲
R/L264.0820.10	.079	.002	8°	02	▲/▲	▲/▲		▲/▲
R/L264.1520.10	.079	.002	15°	02	▲/▲	▲/▲		▲/▲
R/L264.0825.10	.098	.004	8°	03	x/x	▲/▲		▲/▲
R/L264.1525.10	.098	.004	15°	03	x/x	▲/▲		▲/▲
R/L264.0830.10	.118	.004	8°	04	x/x	▲/▲		▲/▲
R/L264.1530.10	.118	.004	15°	04	x/x	▲/▲		▲/▲

▲ on stock Δ 4 weeks x upon request

● recommended

○ alternative recommendation

- not suitable

□ uncoated grades

■ coated grades

■ brazed/Cermet

Dimensions in inch

State R or L version

Indexable inserts can be used in right and left hand toolholders.

P	○	●	●	●
M	-	●	●	●
K	-	●	●	●
N	-	●	●	●
S	-	●	●	●
H	-	-	-	-

Carbide grades

K

Indexable insert

264

Depth of groove up to .630"
Width of groove .059 - .118"

precision ground

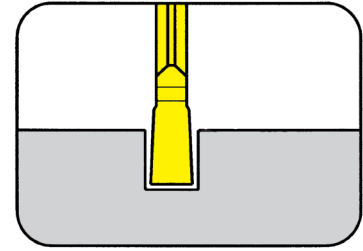

for Toolholder

Type H264

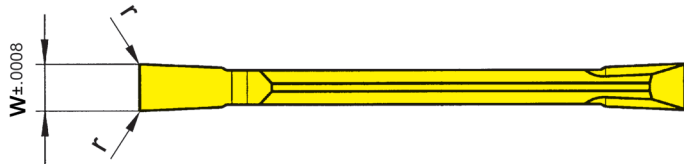
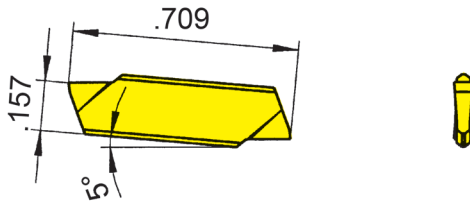

Indexability length ± .0006"

Part number	w	r	Size	Carbide grades			
				MG12	TH35	TI25	TN35
264.0150.20	.059	.002	01	x	▲	x	▲
264.0200.20	.079	.002	02	x	▲		▲
264.0250.20	.098	.004	03	x	▲		▲
264.0300.20	.118	.004	04	x	▲		▲
				P	o	•	•
				M	-	•	•
				K	-	•	•
				N	-	•	•
				S	-	•	•
				H	-	-	-

▲ on stock Δ 4 weeks x upon request
● recommended
o alternative recommendation
- not suitable
□ uncoated grades
■ coated grades
■ brazed/Cermet

Dimensions in inch

Indexable inserts can be used in right and left hand toolholders.



Indexable insert

264

Depth of groove up to .630"
Width of groove .059 - .118"

precision ground

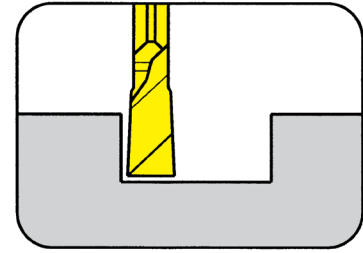

for Toolholder

Type H264

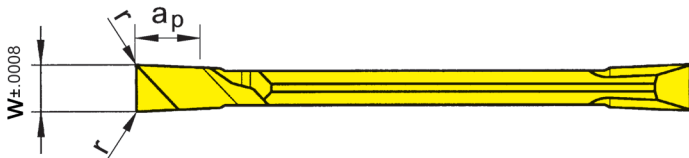
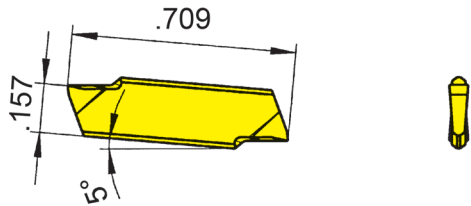

L = left hand version shown

R = right hand version

Indexability length ± .0006"

Part number	w	r	Size	MG12	TH35	T125	TN35
R/L264.0150.P0	.059	.002	01	x/x	▲/▲	▲/▲	▲/▲
R/L264.0200.P0	.079	.002	02	▲/▲	▲/▲	▲/▲	▲/▲
R/L264.0200.P2	.079	.008	02				Δ/Δ
R/L264.0250.P0	.098	.004	03	▲/x	▲/▲	▲/x	▲/x
R/L264.0250.P2	.098	.008	03				Δ/x
R/L264.0300.P0	.118	.004	04	▲/x	▲/▲	▲/▲	▲/▲
R/L264.0300.P2	.118	.008	04				Δ/x

▲ on stock Δ 4 weeks x upon request

● recommended
○ alternative recommendation
- not suitable

□ uncoated grades
■ coated grades
■ brazed/Cermet

Dimensions in inch

$$a_p = 1.5 \times w$$

	P	M	K	N	S	H
MG12	○	-	-	-	-	-
TH35	●	●	●	●	●	-
T125	●	●	●	●	●	-
TN35	●	●	●	●	●	-

Carbide grades

State R or L version

Indexable inserts can be used in right and left hand toolholders.



Indexable insert

264

Depth of groove up to .630"
Width of groove .059 - .118"

precision sintered

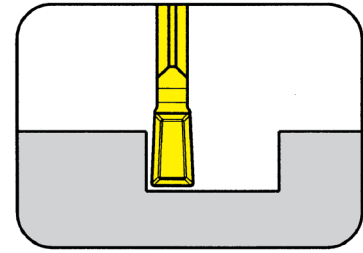

for Toolholder

Type H264

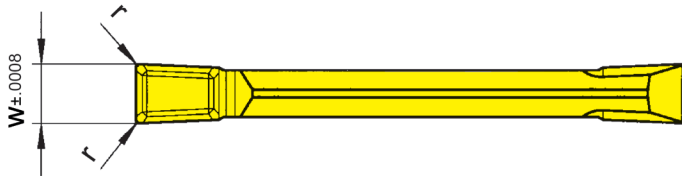
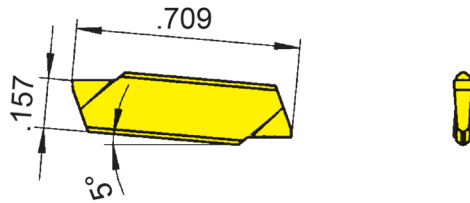

Indexability length ± .0006"

Part number	w	r	Size	Carbide grades	
				MG12	TN35
S264.0150.D1	.059	.002	01	Δ	▲
S264.0200.D1	.079	.002	02	Δ	▲
S264.0250.D1	.098	.004	03	x	▲
S264.0300.D1	.118	.004	04	x	▲

▲ on stock Δ 4 weeks x upon request

- recommended
- alternative recommendation
- not suitable

- uncoated grades
- coated grades
- brazed/Cermet

Dimensions in inch

	MG12	TN35
P	○	●
M	-	●
K	-	●
N	-	●
S	-	●
H	-	-

Carbide grades

Indexable inserts can be used in right and left hand toolholders.



Threading (external) Full profile



Indexable insert

264

Metric ISO-thread

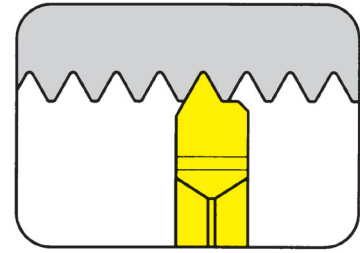

Pitch	.020 - .059"
-------	--------------

precision ground

for Toolholder

Type H264

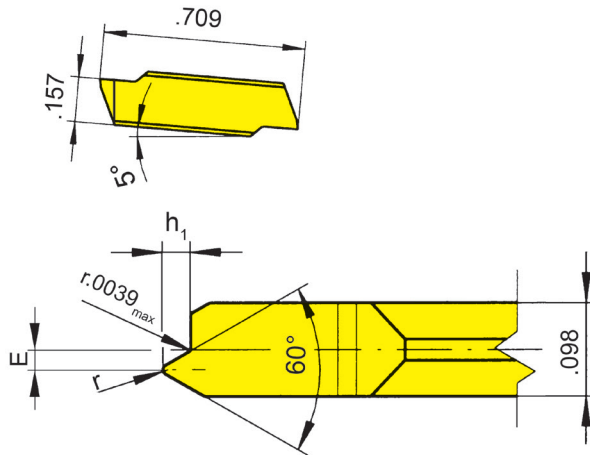

R = right hand version shown

L = left hand version

Indexability length \pm .0006"

Part number	P mm	E	r	h ₁	Size	TF45
R/L264.0305.02	0.50	.035	.0028	.012	03	▲▲
R/L264.0306.02	0.60	.035	.0035	.015	03	▲▲
R/L264.0307.02	0.70	.031	.0039	.017	03	▲▲
R/L264.0407.02	0.75	.030	.0043	.018	03	▲▲
R/L264.0408.02	0.80	.028	.0047	.019	03	▲▲
R/L264.0610.02	1.00	.024	.0047	.024	03	▲▲
R/L264.0712.02	1.25	.020	.0059	.030	03	▲▲
R/L264.0915.02	1.50	.016	.0079	.036	03	▲▲

▲ on stock Δ 4 weeks x upon request

● recommended

o alternative recommendation

- not suitable

□ uncoated grades

■ coated grades

■ brazed/Cermet

Dimensions in inch

P	•
M	•
K	•
N	•
S	•
H	-

Carbide grades

State R or L version

No shims necessary. All HORN thread profiles are manufactured with **fully ground radial clearance**.





K

274

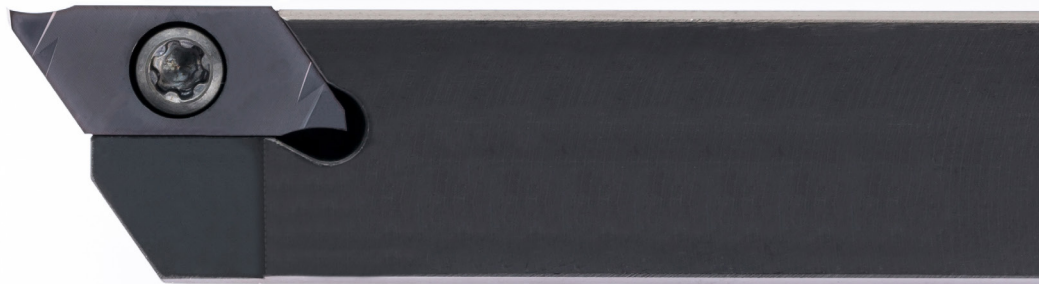

Toolholder with Inserts

Width of groove .020 - .276"

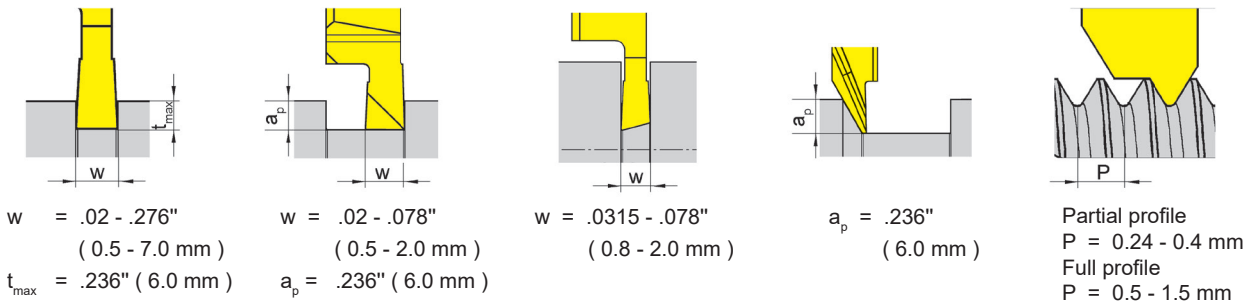

Toolholder
HU274/H274/
H274...E

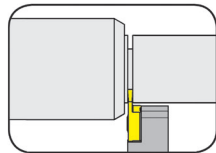

Indexable Insert
S274/S274...E/
S274...SF

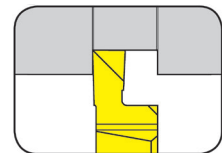

Page
L3-L4, L7-L8, L33

Page
L15-L16, L35-L36

Toolholder
HU274/H274

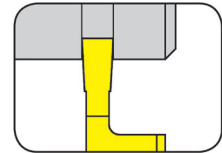
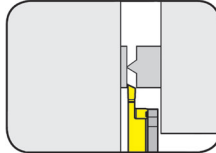

Page
L5,L6

Page
L17-L19, L37-L39

Toolholder
HC274

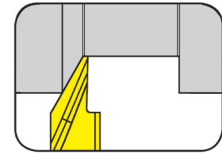
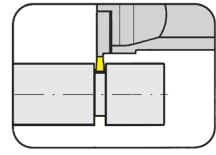

Page
L10

Page
L20, L40

Toolholder
H274

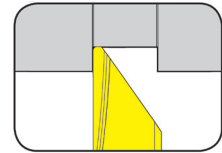
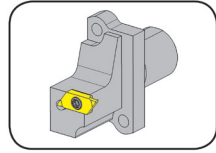

Page
L11

Page
L21-L22, L41

Toolholder Graf
974

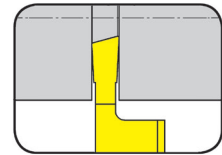
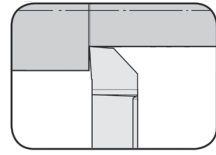
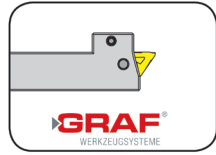

Page
L9

Page
L54

Page
L23-L28, L42-L47

Cartridge
KT274/KTC274

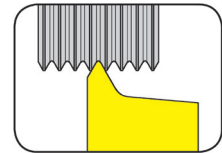
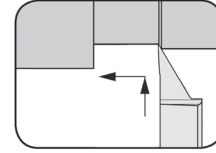
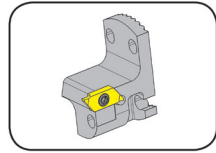

Page
L12-L13

Page
L55-L56

Page
L29-L30, L48-L49

Graf Cartridge
76

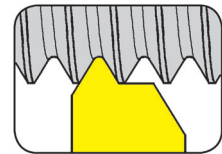
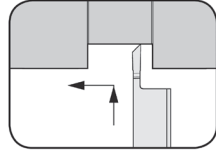
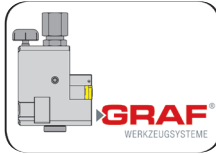

Page
L14

Page
L57-L60

Page
L31-L32, L50-L51



Toolholder

HU274

Depth of groove	.236"
Width of groove	.020 - .118"

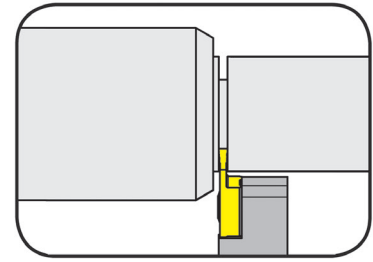

for Indexable insert

Type S274
274

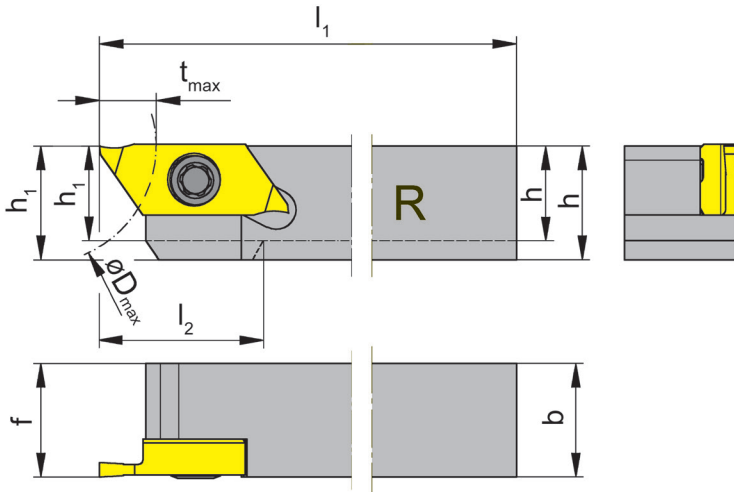

R = right hand version shown

L = left hand version

Part number	h	b	l ₁	l ₂	h ₁	f	t _{max}	D _{max}	Size
R/LHU274.0312.04	.312	.312	3.996	.630	.400	.312	.236	.984	04
R/LHU274.0375.04	.375	.375	3.996	-	.375	.375	.236	.984	04
R/LHU274.0500.04	.500	.500	3.996	-	.500	.500	.236	.984	04
R/LHU274.0625.04	.625	.625	5.118	-	.625	.625	.236	.984	04
R/LHU274.0750.04	.750	.750	5.000	-	.750	.750	.236	.984	04

State R or L version

Dimensions in inch

Further sizes upon request

For torque specification of the screw, please see Technical Instructions.

Spare Parts

Toolholder	Clamping Screw	TORX PLUS® Wrench
R/LHU274.0312.04	030.350P.0744	T15PQ
R/LHU274....	030.3509.T15P	T15PQ



Toolholder

H274

Depth of groove
Width of groove

6 mm
0.5 - 3 mm

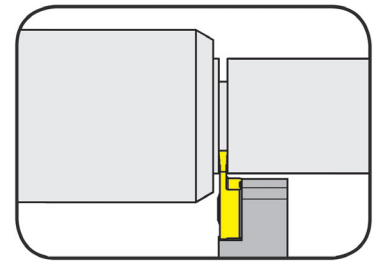

for Indexable insert

Type S274
274

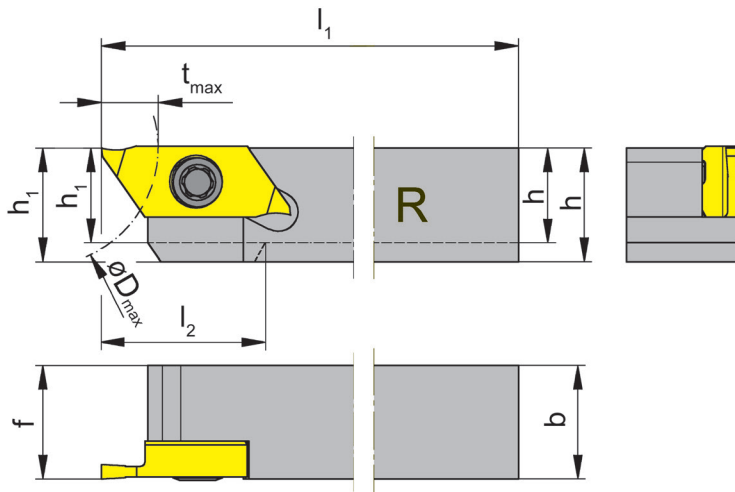

R = right hand version shown

L = left hand version

Part number	h	b	l ₁	l ₂	h ₁	f	t _{max}	D _{max}	Size
R/LH274.0808.04	8	8	100	16	8	8	6	25	04
R/LH274.1010.04	10	10	100	-	10	10	6	25	04
R/LH274.1212.04	12	12	100	-	12	12	6	25	04
R/LH274.1414.04	14	14	100	-	14	14	6	25	04
R/LH274.1616.04	16	16	125	-	16	16	6	25	04
R/LH274.2020.04	20	20	125	-	20	20	6	25	04

State R or L version

Dimensions in mm

Further sizes upon request

For torque specification of the screw, please see Technical Instructions.

Spare Parts

Toolholder	Clamping Screw	TORX PLUS® Wrench
R/LH274.0808.04	030.350P.0744	T15PQ
R/LH274...	030.3509.T15P	T15PQ

Toolholder

H274

Depth of groove 6 mm
Width of groove 0.5 - 3 mm

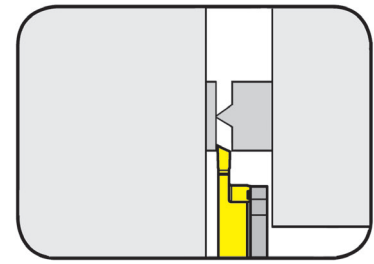

for Indexable insert

Type S274
274

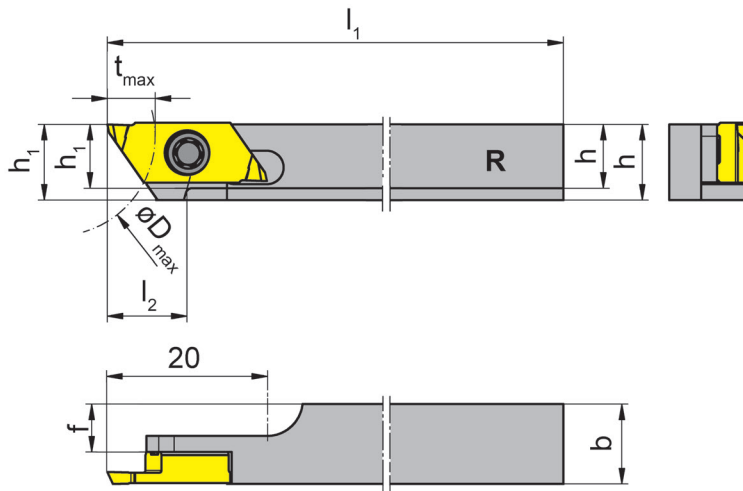

R = right hand version shown

Part number	h	b	l ₁	l ₂	h ₁	f	t _{max}	D _{max}	Size
RH274.0808.6.04	8	8	100	10	9.5	4	6	25	04
RH274.1010.6.04	10	10	100	10	9.5	6	6	25	04
RH274.1212.6.04	12	12	100	10	9.5	8	6	25	04

Dimensions in mm

Further sizes upon request

For torque specification of the screw, please see Technical Instructions.

Spare Parts

Toolholder	Clamping Screw	TORX PLUS® Wrench
RH274...	030.350P.0981	T15PQ

Toolholder

H274

Depth of groove
Width of groove

6 mm
0.5 - 3 mm

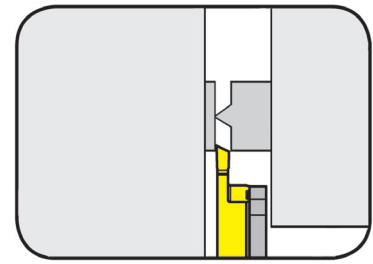

for Indexable insert

Type S274
274

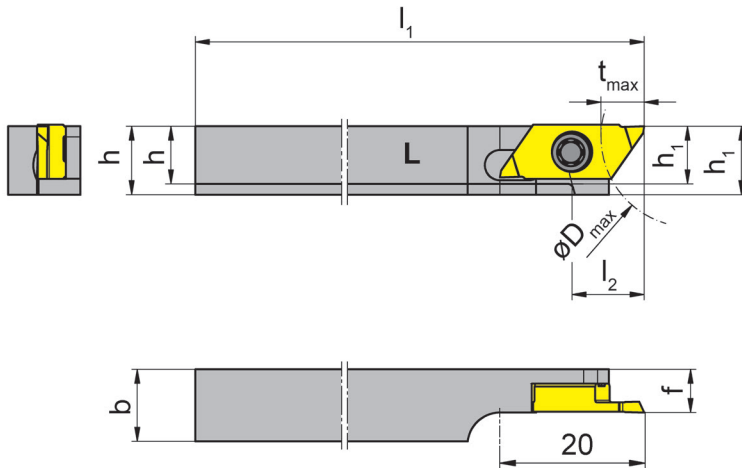

L = left hand version shown

Part number	h	b	l ₁	l ₂	h ₁	f	t _{max}	D _{max}	Size
LH274.0808.6.04.M	8	8	100	10	9.5	6	6	25	04
LH274.1010.6.04.M	10	10	100	10	9.5	6	6	25	04
LH274.1212.6.04.M	12	12	100	10	9.5	6	6	25	04

Dimensions in mm

Further sizes upon request

For torque specification of the screw, please see Technical Instructions.

L

Spare Parts

Toolholder	Clamping Screw	TORX PLUS® Wrench
LH274...	030.350P.0981	T15PQ

Toolholder

HU274

Depth of groove	.236"
Width of groove up to	.280"

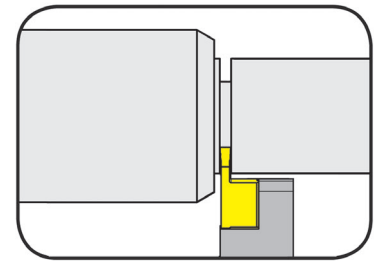

for Indexable insert

Type S274
274

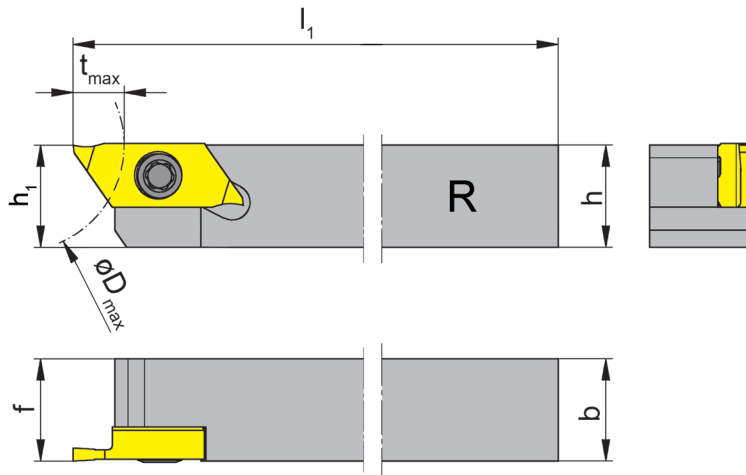

R = right hand version shown

L = left hand version

for special widths

Part number	h	b	l ₁	h ₁	f	t _{max}	D _{max}	Size
R/LHU274.0500.07	.500	.551	3.996	.500	.551	.236	.984	07

State R or L version

Dimensions in inch

Further sizes upon request

For torque specification of the screw, please see Technical Instructions.

Spare Parts

Toolholder	Clamping Screw	TORX PLUS® Wrench
R/LHU274.0500.07	030.3513.T15P	T15PQ



Toolholder

H274

Depth of groove
Width of groove up to

6 mm
7 mm

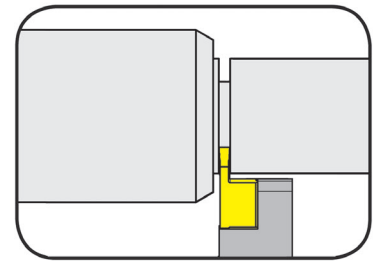

for Indexable insert

Type S274
274

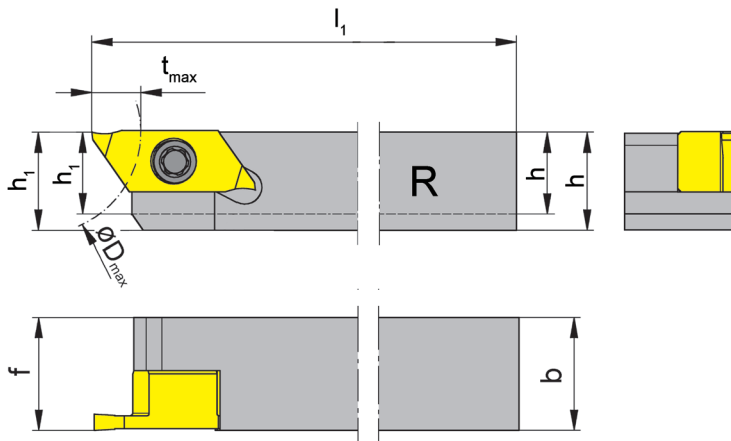

R = right hand version shown

L = left hand version

for special widths

Part number	h	b	l ₁	h ₁	f	t _{max}	D _{max}	Size
R/LH274.1214.07	12	14	100	12	14	6	25	07
R/LH274.1616.07	16	16	125	16	16	6	25	07

State R or L version

Dimensions in mm

Further sizes upon request

For torque specification of the screw, please see Technical Instructions.

L

Spare Parts

Toolholder	Clamping Screw	TORX PLUS® Wrench
R/LH274...	030.3513.T15P	T15PQ

L8

Call Us Toll Free (888) 818-4676

Toolholder Graf

974

with through coolant supply



Depth of groove 6 mm
Width of groove 0.5 - 3 mm

for Indexable insert

Type S274
274

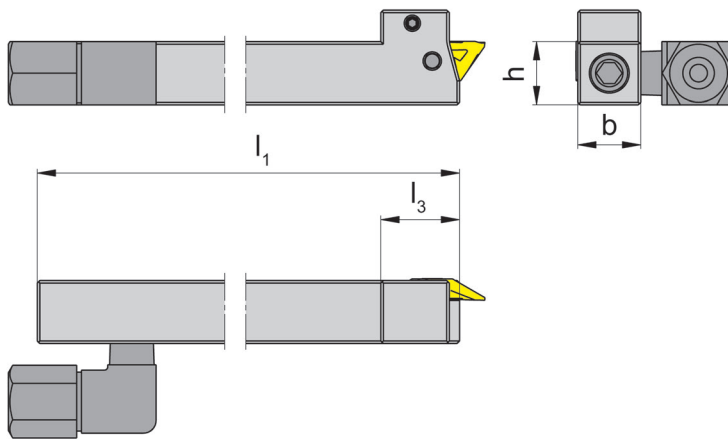

R = right hand version shown

L = left hand version

Part number	h	b	l ₁	l ₃	Size
974.L.1012.04.IK	10	12	100	15	04
974.R.1012.04.IK	10	12	100	15	04
974.L.1212.04.IK	12	12	100	15	04
974.R.1212.04.IK	12	12	100	15	04
974.L.1616.04.IK	16	16	100	15	04
974.R.1616.04.IK	16	16	100	15	04
974.L.2020.04.IK	20	20	100	15	04
974.R.2020.04.IK	20	20	100	15	04

Further sizes upon request

Dimensions in mm

For torque specification of the screw, please see Technical Instructions.



Grooving and Side Turning (external)



Toolholder

HC274

Depth of groove up to
Width of groove up to

4 mm
3 mm

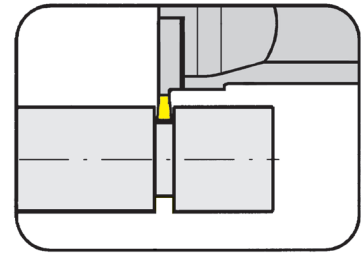

for Indexable insert

Type LS274
L274

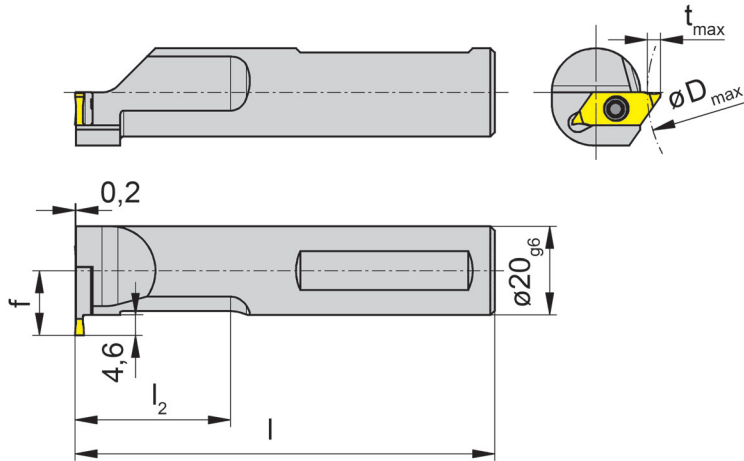

Depth of groove in relation to bore \varnothing

D_{max}	t_{max}
40	2,0
60	3,0
120	3,5

TRAUB TNL18 / 32

R = right hand version shown

Part number	l	l ₂	f	t _{max}	Size
RHC274.0020.1.04	95	35	14.6	4	04

Further sizes upon request

Dimensions in mm

Ordering note:

Use left hand insert in right hand toolholder.

For torque specification of the screw, please see Technical Instructions.

Spare Parts

Toolholder	Clamping Screw	TORX PLUS® Wrench
RHC274.0020.1.04	030.3509.T15P	T15PQ

L10

Call Us Toll Free (888) 818-4676

Toolholder

H274

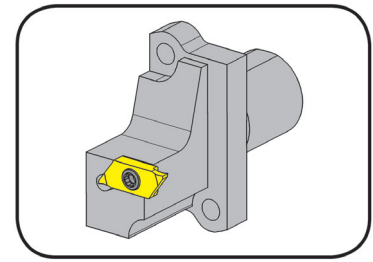

Depth of groove up to
Width of groove up to

6 mm
7 mm

Hole pattern 13,7 x 37,6 mm

for Indexable insert

Type S274
274

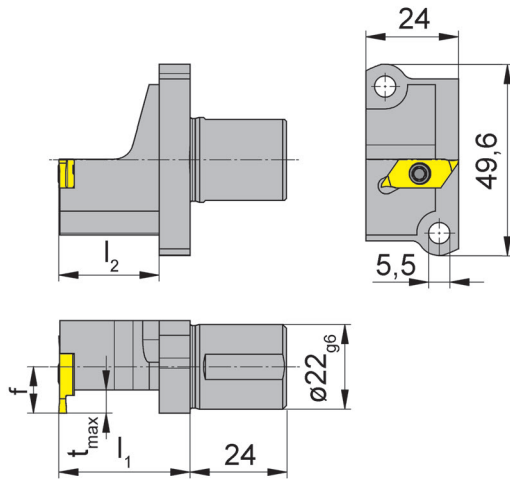

R = right hand version shown

L = left hand version

for Swiss type machines
Star

Part number	f	l_1	t_{max}	l_2	Size
R/LH274.A022.09.04	9	34	6	26	04
R/LH274.A022.12.04	12	34	6	26	04
R/LH274.A022.16.04	16	34	6	26	04
R/LH274.A022.09.07	9	34	6	26	07
R/LH274.A022.12.07	12	34	6	26	07

State R or L version

Dimensions in mm

Further sizes upon request

Ordering note:

Use right hand inserts in left hand toolholders and left hand inserts in right hand toolholders

For torque specification of the screw, please see Technical Instructions.

Spare Parts

Toolholder	Clamping Screw	TORX PLUS® Wrench
R/LH274...	030.3513.T15P	T15PQ



Cartridge

KT274

Depth of groove up to
Width of groove

6 mm
0.5 - 3 mm

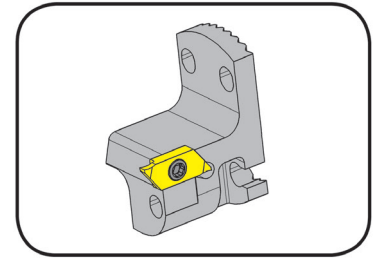

for Indexable insert

Type S274
274

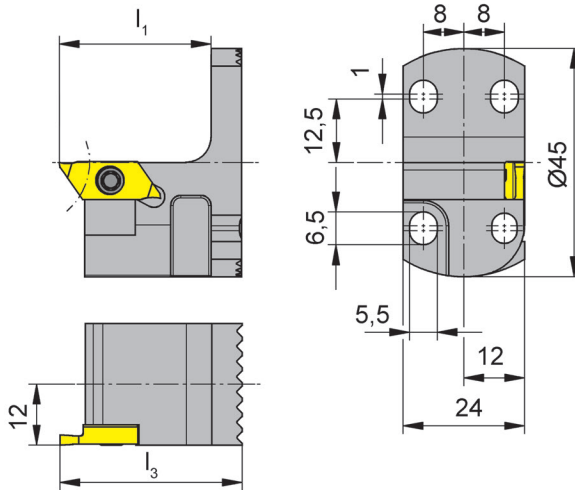

R = right hand version shown

L = left hand version

Part number	l_3	l_1	Size
R/LKT274.2445.04	36	30	04

State R or L version

Dimensions in mm

Further sizes upon request

For torque specification of the screw, please see Technical Instructions.

L

Spare Parts

Cartridge	Clamping Screw	TORX PLUS® Wrench
R/LKT274.2445.04	030.3509.T15P	T15PQ

L12

Call Us Toll Free (888) 818-4676

Cartridge

KTC274

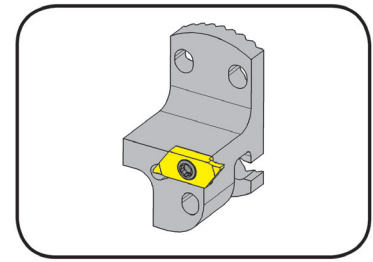

Depth of groove up to
Width of groove

6 mm
0.5 - 3 mm

for Indexable insert

Type LS274
L274

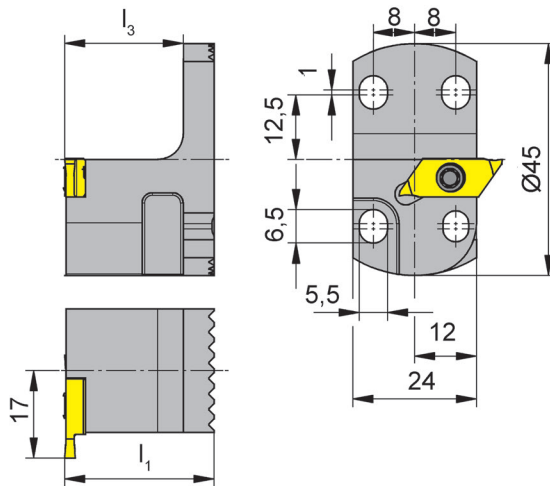

R = right hand version shown

Part number	l_1	l_3	Size
RKTC274.2445.04	29	23	04

Further sizes upon request

Dimensions in mm

Ordering note:

Use left hand insert in right hand toolholder.

For torque specification of the screw, please see Technical Instructions.

Spare Parts

Cartridge	Clamping Screw	TORX PLUS® Wrench
RKTC274.2445.04	030.3509.T15P	T15PQ



Cartridge Graf

76

with through coolant supply



Depth of groove 6 mm
Width of groove 0.5 - 3 mm

for Indexable insert

Type S274
274

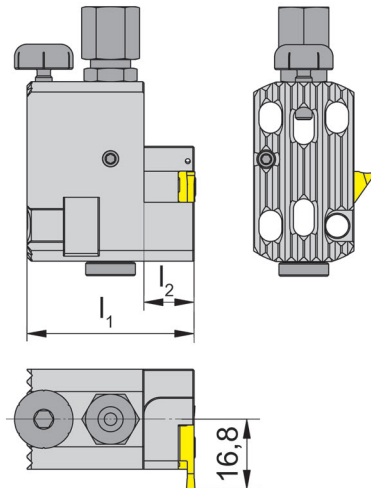

R = right hand version shown

Part number	l_1	l_2	Size
R.76.IK	40	12	04

Further sizes upon request

Dimensions in mm

Ordering note:

Use right hand insert in right hand toolholder.

For torque specification of the screw, please see Technical Instructions.

Spare Parts

Cartridge Graf	Screw to adjust the height	Coolant supply	Clamping Screw	TORX PLUS® Wrench
R.76.IK	002.00.69	004.00.19	030.3509.T15P	T15PQ

L14

Call Us Toll Free (888) 818-4676

Indexable insert

S274

Depth of groove up to .177"
Width of groove .020 - .118"

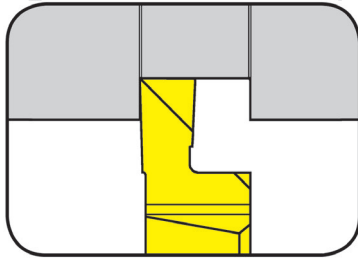

precision ground

for Toolholder

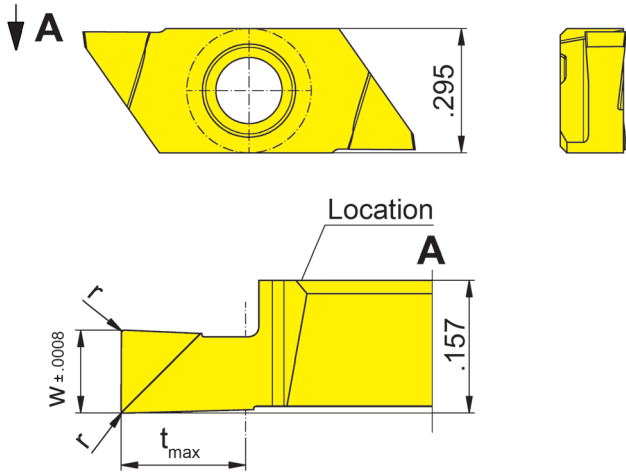

Type H274/HU274
KT274
KTC274
974
76
H274KM
HC274KM

Indexability length ± .0006"

R = right hand version shown

L = left hand version

Part number	w	r	t _{max}	Size	AN25	IG35	TH35	
R/LS274.0050.P0	.020	-	.039	04	▲/▲	▲/▲	×/▲	
R/LS274.0100.P0	.039	-	.079	04	▲/▲	▲/▲	▲/▲	
R/LS274.0150.P0	.059	.002	.089	04		▲/▲	▲/▲	
R/LS274.0200.P0	.079	.002	.118	04		▲/Δ	▲/▲	
R/LS274.0250.P0	.098	.004	.148	04		▲/▲	▲/▲	
R/LS274.0300.P0	.118	.004	.177	04		▲/Δ	▲/▲	
					P	•	-	•
					M	o	•	•
					K	-	-	•
					N	-	-	•
					S	-	•	•
					H	-	-	-

▲ on stock Δ 4 weeks x upon request

• recommended

o alternative recommendation

- not suitable

□ uncoated grades

■ coated grades

■ brazed/Cermet

Dimensions in inch

State R or L version

Carbide grades



Indexable insert

S274

Depth of groove up to Full radius .157"
.010 - .039"

precision ground

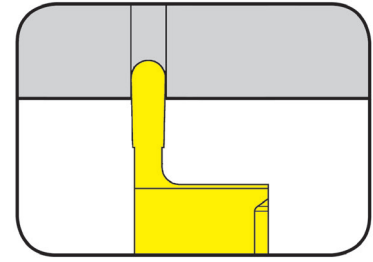

for Toolholder

Type H274/HU274
KT274
KTC274
974
76
H274KM
HC274KM

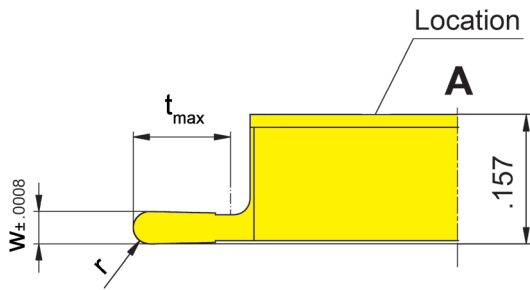
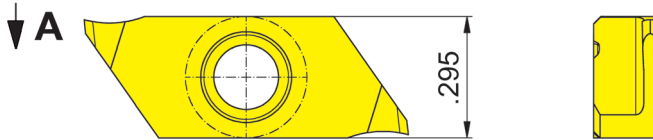

R = right hand version shown

L = left hand version

Indexability length ± .0006"

Part number	w	t _{max}	r	Size	IG35	TH35
R/LS274.0205.01.10	.020	.059	.010	04	▲/▲	▲/▲
R/LS274.0510.03.10	.039	.118	.020	04	▲/▲	▲/▲
R/LS274.1020.04.10	.079	.157	.039	04	▲/▲	▲/▲

▲ on stock Δ 4 weeks x upon request

- recommended
- alternative recommendation
- not suitable

- uncoated grades
- coated grades
- brazed/Cermet

Dimensions in inch

State R or L version

	IG35	TH35
P	-	●
M	●	●
K	-	●
N	-	●
S	●	●
H	-	-

Carbide grades



Indexable insert

S274

Depth of groove up to	.236"
Width of groove	.020 - .079"

precision ground

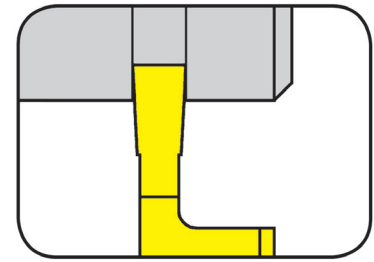

for Toolholder

Type H274/HU274
KT274
KTC274
974
76
H274KM
HC274KM

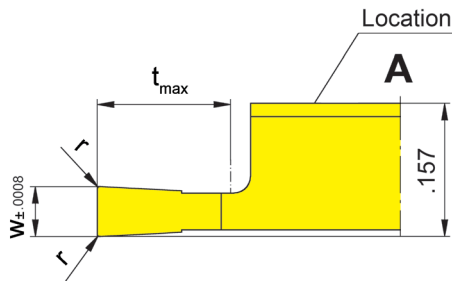
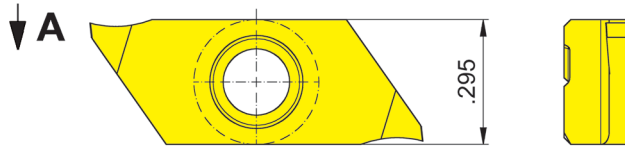

R = right hand version shown

L = left hand version

Indexability length ± .0006"

Part number	w	r	t _{max}	Size	IG35	TH35
R/LS274.0050.01.10	.020	.002	.059	04	▲/▲	▲/▲
R/LS274.0070.02.10	.028	.002	.079	04	x/Δ	▲/▲
R/LS274.0080.03.10	.031	.002	.118	04	▲/▲	▲/▲
R/LS274.0100.03.10	.039	.002	.118	04	▲/▲	▲/▲
R/LS274.0120.03.10	.047	.002	.118	04	▲/▲	▲/▲
R/LS274.0150.04.10	.059	.002	.157	04	▲/▲	▲/▲
R/LS274.0150.06.10	.059	.002	.236	04	▲/▲	▲/▲
R/LS274.0200.04.10	.079	.002	.157	04	▲/▲	▲/▲
R/LS274.0200.06.10	.079	.002	.236	04	▲/▲	▲/▲

▲ on stock Δ 4 weeks x upon request

● recommended
o alternative recommendation
- not suitable

□ uncoated grades
■ coated grades
■ brazed/Cermet

Dimensions in inch

State R or L version

P	-	•
M	•	•
K	-	•
N	-	•
S	•	•
H	-	-

Carbide grades



Indexable insert

S274

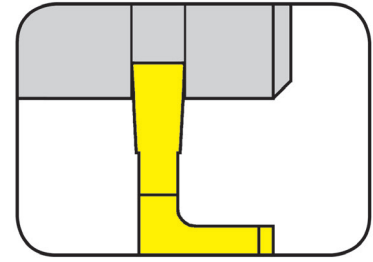

Depth of groove up to .236"
 Width of groove .020 - .079"

precision ground

for Toolholder

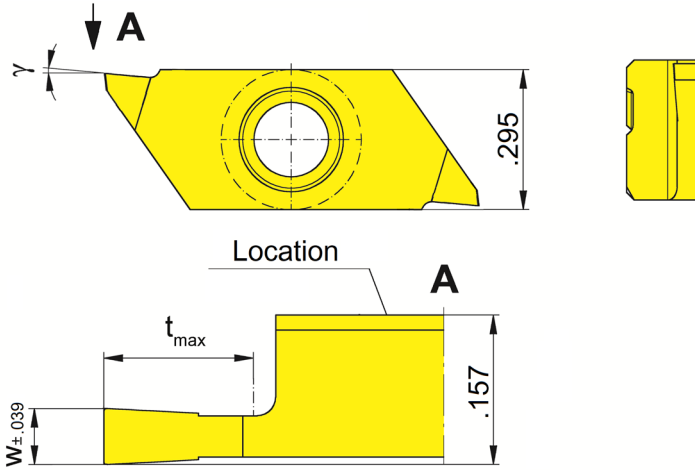

Type H274/HU274
 KT274
 KTC274
 974
 76
 H274KM
 HC274KM

Indexability length \pm
 .0006"

R = right hand version shown

L = left hand version

Part number	w	t _{max}	γ	Size	IG35	TH35
R/LS274.0050.01.20	.020	.059	5°	04	▲/▲	▲/▲
R/LS274.0070.02.20	.028	.079	5°	04	△/△	▲/▲
R/LS274.0080.03.20	.031	.118	5°	04	△/△	▲/▲
R/LS274.0100.03.20	.039	.118	5°	04	▲/△	▲/▲
R/LS274.0120.03.20	.047	.118	5°	04	△/△	▲/▲
R/LS274.0150.04.20	.059	.157	5°	04	▲/▲	▲/▲
R/LS274.0150.06.20	.059	.236	5°	04	△/△	▲/▲
R/LS274.0200.04.20	.079	.157	5°	04	△/△	▲/▲
R/LS274.0200.06.20	.079	.236	5°	04	△/△	▲/▲

▲ on stock △ 4 weeks x upon request

- recommended
- alternative recommendation
- not suitable

- uncoated grades
- coated grades
- brazed/Cermet

Dimensions in inch

State R or L version

	IG35	TH35
P	-	●
M	●	●
K	-	●
N	-	●
S	●	●
H	-	-

Carbide grades



Indexable insert

S274

Depth of groove up to .236"
 Width of groove .020 - .079"

precision ground

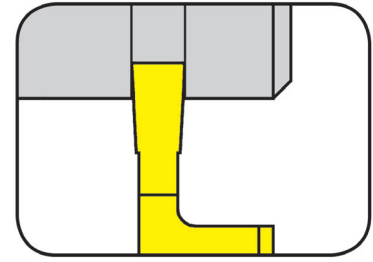

for Toolholder

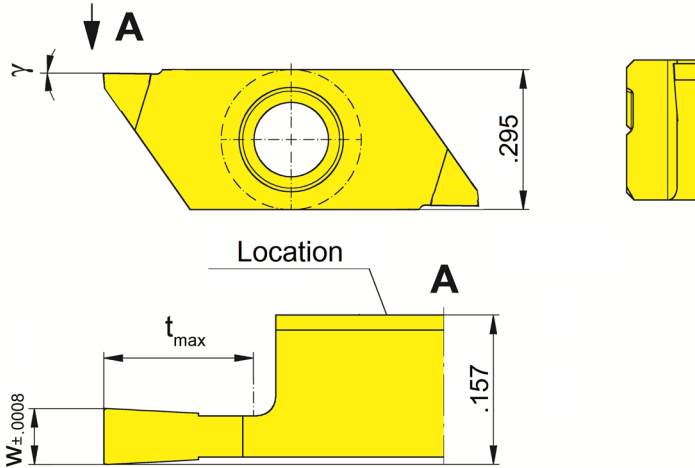

Type H274/HU274
 KT274
 KTC274
 974
 76
 H274KM
 HC274KM

Indexability length \pm
 .0006"

R = right hand version shown

L = left hand version

Part number	w	t _{max}	γ	Size	IG35	TH35
R/LS274.0050.01.M0	.020	.059	0°	04	ΔΔ	▲▲
R/LS274.0070.02.M0	.028	.079	0°	04	Δ▲	▲▲
R/LS274.0080.03.M0	.031	.118	0°	04	ΔΔ	▲▲
R/LS274.0100.03.M0	.039	.118	0°	04	ΔΔ	▲▲
R/LS274.0120.03.M0	.047	.118	0°	04	ΔΔ	▲▲
R/LS274.0150.04.M0	.059	.157	0°	04	ΔΔ	▲▲
R/LS274.0150.06.M0	.059	.236	0°	04	ΔΔ	▲▲
R/LS274.0200.04.M0	.079	.157	0°	04	ΔΔ	▲▲
R/LS274.0200.06.M0	.079	.236	0°	04	ΔΔ	▲▲

▲ on stock Δ 4 weeks x upon request

● recommended
 ○ alternative recommendation
 - not suitable

□ uncoated grades
 ■ coated grades
 ■ brazed/Cermet

Dimensions in inch

State R or L version

	IG35	TH35
P	-	●
M	●	●
K	-	●
N	-	●
S	●	●
H	-	-

Carbide grades



Backturning (external)



Indexable insert

S274

Depth of cut up to .236"

precision ground

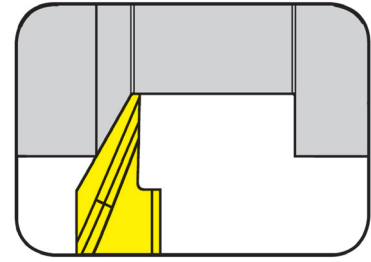

for Toolholder

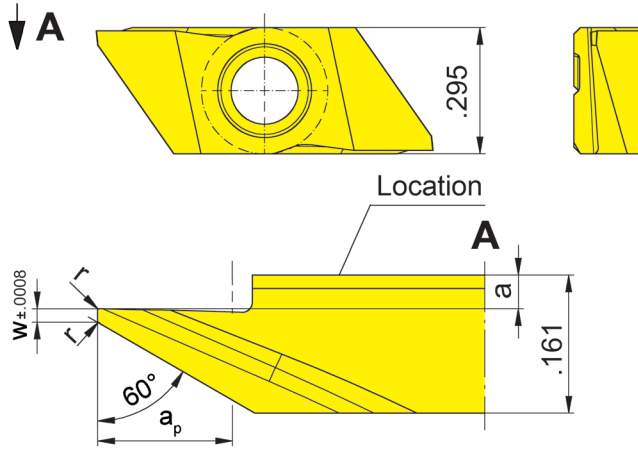

Type H274/HU274
KT274
KTC274
974
76
H274KM
HC274KM

Indexability length ± .0006"

R = right hand version shown

L = left hand version

Part number	w	r	a	γ	a _p	Size	K10	IG35	TH35
R/LS274.0060.04.10	.039	.002	.039	15°	.157	04		▲/Δ	▲/▲
R/LS274.0460.04.10	.016	.002	.039	15°	.157	04		▲/▲	▲/▲
R/LS274.0460.04.M0	.016	.002	.039	0°	.157	04	▲/▲	Δ/Δ	x/x
R/LS274.0560.06.11	.020	.004	.002	15°	.236	04		▲/▲	▲/▲

▲ on stock Δ 4 weeks x upon request

● recommended
○ alternative recommendation
- not suitable

□ uncoated grades
■ coated grades
■ brazed/Cermet

Dimensions in inch

State R or L version

γ = rake angle

	P	M	K	N	S	H
K10	●	○	●	●	○	-
IG35	-	●	-	-	●	-
TH35	●	●	●	●	●	-

Carbide grades



Indexable insert

S274

Depth of cut up to .236"

precision ground

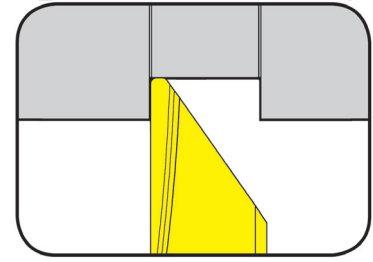

for Toolholder

Type H274/HU274
KT274
KTC274
974
76
H274KM
HC274KM

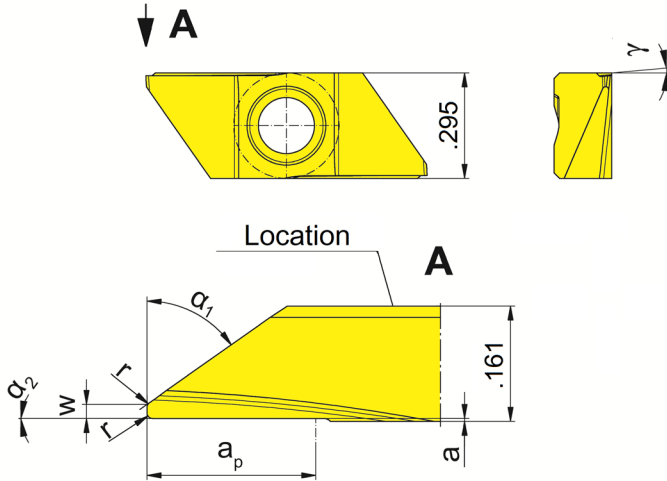

R = right hand version shown

L = left hand version

Indexability length ± .0006"

Part number	w	r	α_1	a	γ	a_p	α_2	Size	IG35	TH35
R/LS274.0035.04.20	-	.002	35°	.004	5°	.157	0°	04	▲/△	▲/▲
R/LS274.0055.04.20	-	.002	55°	.004	5°	.157	0°	04	△/△	▲/▲
R/LS274.0235.04.20	.008	-	35°	.004	5°	.157	0°	04	▲/△	▲/▲
R/LS274.0255.04.20	.008	-	55°	.004	5°	.157	0°	04	△/△	▲/▲
R/LS274.0535.06.20	.020	.008	35°	.004	5°	.236	0°	04	▲/△	▲/▲
R/LS274.0555.06.20	.020	.008	55°	.004	5°	.236	0°	04	▲/▲	▲/▲

▲ on stock △ 4 weeks x upon request
● recommended
o alternative recommendation
- not suitable
■ uncoated grades
■ coated grades
■ brazed/Cermet
Dimensions in inch

	P	M	K	N	S	H
IG35	-	●	-	-	●	-
TH35	●	●	●	●	●	-

Carbide grades

State R or L version



Indexable insert

S274

Depth of cut up to .236"

precision ground

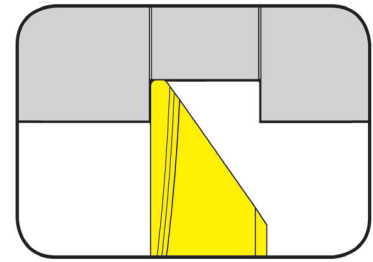

for Toolholder

Type H274/HU274
KT274
KTC274
974
76
H274KM
HC274KM

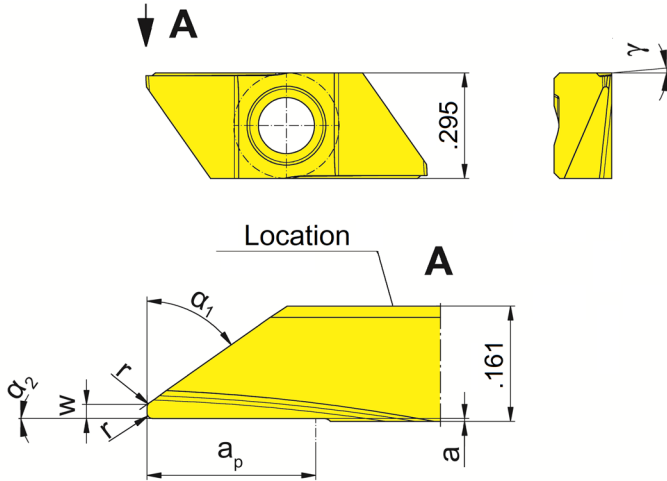

R = right hand version shown

L = left hand version

Indexability length ± .0006"

Part number	w	r	α_1	a	γ	a_p	α_2	Size	IG35	TH35
R/LS274.0035.24.20	-	.002	35°	.004	5°	.157	2°	04	▲/▲	▲/▲
R/LS274.0235.24.20	.008	-	35°	.004	5°	.157	2°	04	△/▲	▲/△
R/LS274.0535.26.20	.020	.008	35°	.004	5°	.236	2°	04	▲/▲	▲/▲
R/LS274.0055.24.20	-	.002	55°	.004	5°	.157	2°	04	△/▲	▲/▲
R/LS274.0255.24.20	.008	-	55°	.004	5°	.157	2°	04	△/△	▲/△
R/LS274.0555.26.20	.020	.008	55°	.004	5°	.236	2°	04	△/△	▲/△

▲ on stock △ 4 weeks x upon request

● recommended

o alternative recommendation

- not suitable

□ uncoated grades

■ coated grades

■ brazed/Cermet

Dimensions in inch

State R or L version

	IG35	TH35
P	-	•
M	•	•
K	-	•
N	-	•
S	•	•
H	-	-

Carbide grades



Indexable insert

S274

Depth of groove up to .236"
Width of groove .031 - .079"

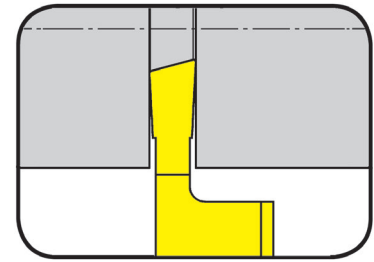

precision ground

for Toolholder

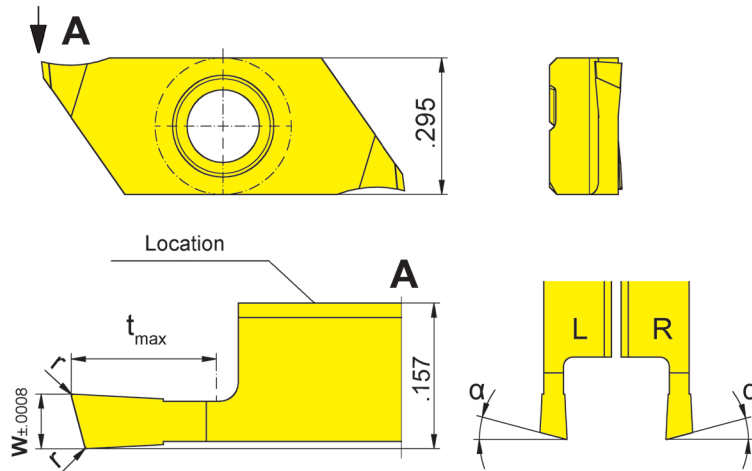

Type H274/HU274
KT274
KTC274
974
76
H274KM
HC274KM

Indexability length \pm .0006"

R = right hand version shown

L = left hand version

Part number	w	r	t _{max}	α	Size	Carbide grades	
						IG35	TH35
R/LS274.1508.03.10	.031	.002	.118	15°	04	▲/▲	▲/▲
R/LS274.1510.03.10	.039	.002	.118	15°	04	▲/▲	▲/▲
R/LS274.1515.04.10	.059	.002	.157	15°	04	▲/▲	▲/▲
R/LS274.1520.06.10	.079	.002	.236	15°	04	▲/▲	▲/▲

▲ on stock Δ 4 weeks x upon request

● recommended
○ alternative recommendation
- not suitable

□ uncoated grades
■ coated grades
■ brazed/Cermet

Dimensions in inch

State R or L version

Note:

t_{max} = .236" can be reached only with workpiece $\varnothing \leq .984$ "

	IG35	TH35
P	-	●
M	●	●
K	-	●
N	-	●
S	●	●
H	-	-

Carbide grades



Indexable insert

S274

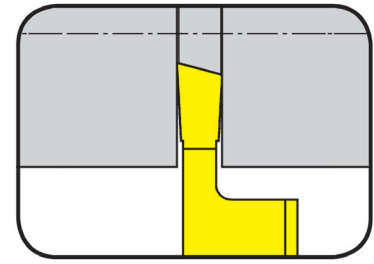

Depth of groove up to
Width of groove

.236"
.031 - .079"

precision ground

for Toolholder

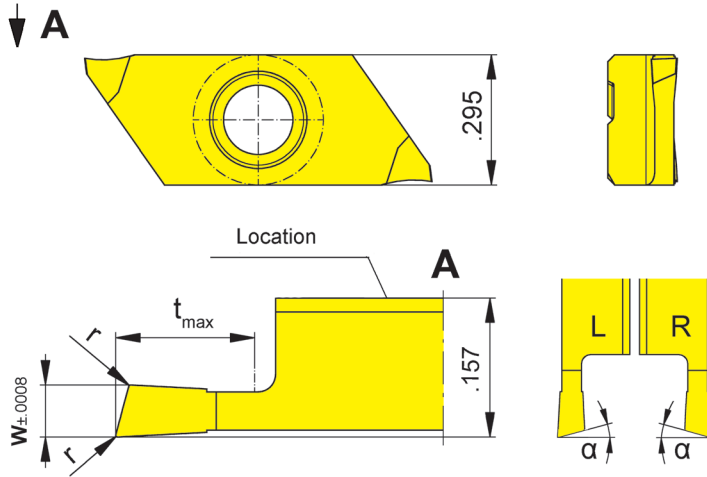

Type H274/HU274
KT274
KTC274
974
76
H274KM
HC274KM

Indexability length ±
.0006"

R = right hand version shown

L = left hand version

Part number	w	r	t _{max}	α	Size	Carbide grades	
						IG35	TH35
LS274.1508.03.10R	.031	.002	.118	15°	04	▲	▲
LS274.1510.03.10R	.039	.002	.118	15°	04	▲	▲
LS274.1515.04.10R	.059	.002	.157	15°	04	▲	▲
LS274.1520.06.10R	.079	.002	.236	15°	04	▲	▲
RS274.1508.03.10L	.031	.002	.118	15°	04	△	▲
RS274.1510.03.10L	.039	.002	.118	15°	04	△	▲
RS274.1515.04.10L	.059	.002	.157	15°	04	△	▲
RS274.1520.06.10L	.079	.002	.236	15°	04	△	▲

▲ on stock △ 4 weeks x upon request

● recommended

○ alternative recommendation

- not suitable

□ uncoated grades

■ coated grades

■ brazed/Cermet

Dimensions in inch

	IG35	TH35
P	-	•
M	•	•
K	-	•
N	-	•
S	•	•
H	-	-

Carbide grades

Note:

t_{max} .236" can be reached only with workpiece Ø ≤ .984".

Indexable insert

S274

Depth of groove up to	.236"
Width of groove	.059 - .079"

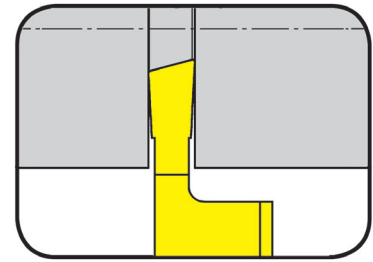

precision ground

for Toolholder

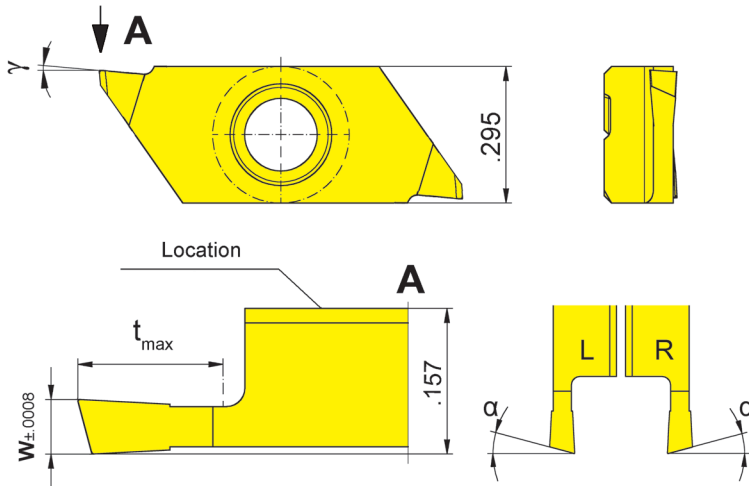

Type H274/HU274
KT274
KTC274
974
76
H274KM
HC274KM

Indexability length ± .0006"

R = right hand version shown

L = left hand version

Part number	w	t _{max}	α	γ	Size	Carbide grades	
						IG35	TH35
R/LS274.1515.04.20	.059	.157	15°	5°	04	Δ/Δ	▲/▲
R/LS274.1520.06.20	.079	.236	15°	5°	04	Δ/Δ	▲/▲

▲ on stock Δ 4 weeks x upon request

- recommended
- alternative recommendation
- not suitable

- uncoated grades
- coated grades
- brazed/Cermet

Dimensions in inch

State R or L version

Note:

t_{max} .236" can be reached only with workpiece Ø ≤ .984".

	IG35	TH35
P	-	●
M	●	●
K	-	●
N	-	●
S	●	●
H	-	-

Carbide grades



Indexable insert

S274

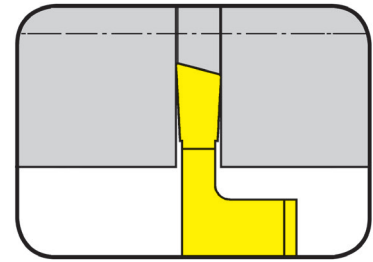

Depth of groove up to
Width of groove

.236"
.059 - .079"

precision ground

for Toolholder

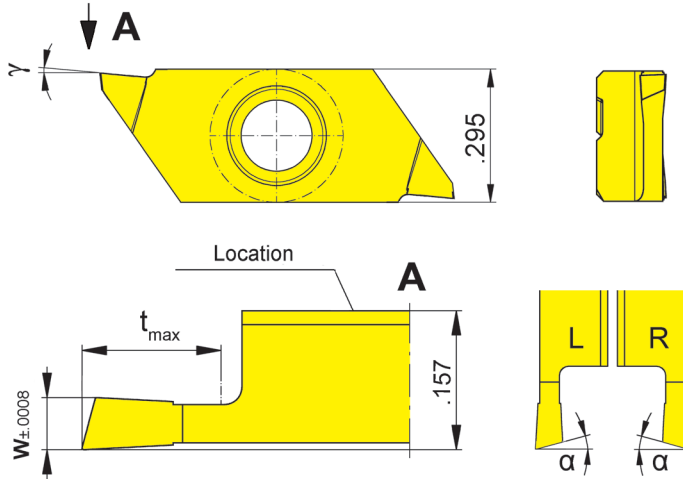

Type H274/HU274
KT274
KTC274
974
76
H274KM
HC274KM

Indexability length ±
.0006"

R = right hand version shown

L = left hand version

Part number	w	t _{max}	α	γ	Size	Carbide grades	
						IG35	TH35
LS274.1515.04.20R	.059	.157	15°	5°	04	Δ	Δ
LS274.1520.06.20R	.079	.236	15°	5°	04	Δ	Δ
RS274.1515.04.20L	.059	.157	15°	5°	04	Δ	Δ
RS274.1520.06.20L	.079	.236	15°	5°	04	Δ	Δ

▲ on stock Δ 4 weeks x upon request

- recommended
- alternative recommendation
- not suitable

- uncoated grades
- coated grades
- brazed/Cermet

Dimensions in inch

	IG35	TH35
P	-	●
M	●	●
K	-	●
N	-	●
S	●	●
H	-	-

Carbide grades

Note:

t_{max} .236" can be reached only with workpiece Ø ≤ .984".

Indexable insert

S274

Depth of groove up to $.236''$
 Width of groove $.031 - .079''$

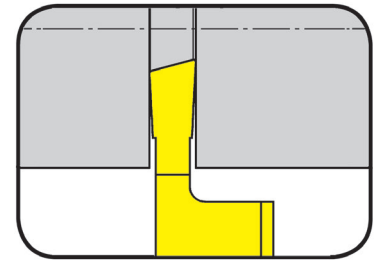

precision ground

for Toolholder

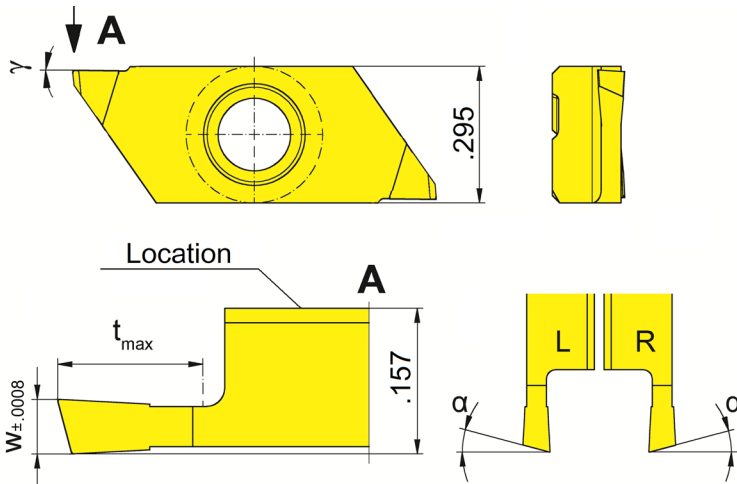

Type H274/HU274
 KT274
 KTC274
 974
 76
 H274KM
 HC274KM

Indexability length $\pm .0006''$

R = right hand version shown

L = left hand version

Part number	w	t _{max}	α	γ	Size	IG35	TH35
R/LS274.1508.03.M0	.031	.118	15°	0°	04	Δ/Δ	Δ/Δ
R/LS274.1510.03.M0	.039	.118	15°	0°	04	Δ/Δ	▲/Δ
R/LS274.1515.04.M0	.059	.157	15°	0°	04	Δ/Δ	Δ/Δ
R/LS274.1520.06.M0	.079	.236	15°	0°	04	Δ/Δ	Δ/Δ

▲ on stock Δ 4 weeks x upon request

- recommended
- alternative recommendation
- not suitable

- uncoated grades
- coated grades
- brazed/Cermet

Dimensions in inch

State R or L version

Note:

t_{max} .236" can be reached only with workpiece $\varnothing \leq .984''$.

	IG35	TH35
P	-	●
M	●	●
K	-	●
N	-	●
S	●	●
H	-	-

Carbide grades



Indexable insert

S274

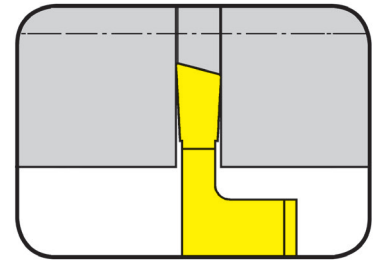

Depth of groove up to
Width of groove

.236"
.031 - .079"

precision ground

for Toolholder

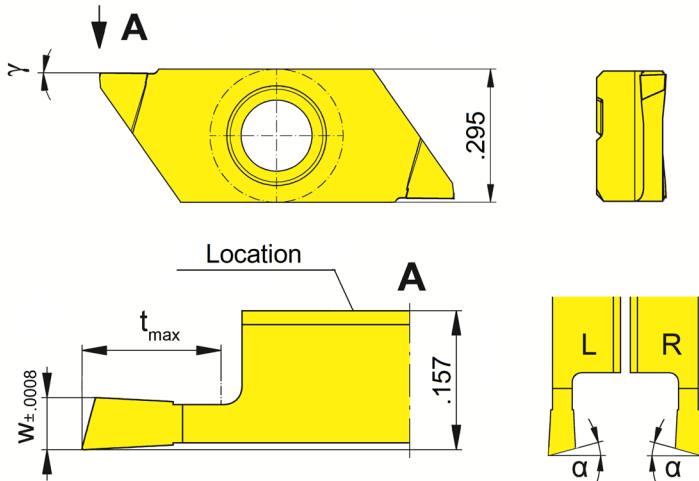

Type H274/HU274
KT274
KTC274
974
76
H274KM
HC274KM

Indexability length ±
.0006"

R = right hand version shown

L = left hand version

Part number	w	t _{max}	α	γ	Size	Carbide grades	
						IG35	TH35
LS274.1508.03.M0R	.031	.118	15°	0°	04	Δ	▲
LS274.1510.03.M0R	.039	.118	15°	0°	04	Δ	Δ
LS274.1515.04.M0R	.059	.157	15°	0°	04	Δ	Δ
LS274.1520.06.M0R	.079	.236	15°	0°	04	Δ	Δ
RS274.1508.03.M0L	.031	.118	15°	0°	04	Δ	Δ
RS274.1510.03.M0L	.039	.118	15°	0°	04	Δ	Δ
RS274.1515.04.M0L	.059	.157	15°	0°	04	Δ	Δ
RS274.1520.06.M0L	.079	.236	15°	0°	04	Δ	Δ

▲ on stock Δ 4 weeks x upon request
● recommended
○ alternative recommendation
- not suitable
■ uncoated grades
■ coated grades
■ brazed/Cermet

Dimensions in inch

	IG35	TH35
P	-	•
M	•	•
K	-	•
N	-	•
S	•	•
H	-	-

Carbide grades

Note:

t_{max} .236" can be reached only with workpiece Ø ≤ .984".

Threading (external) Partial profile



Indexable insert

S274

Pitch	12 - 64 TPI
-------	-------------

precision ground

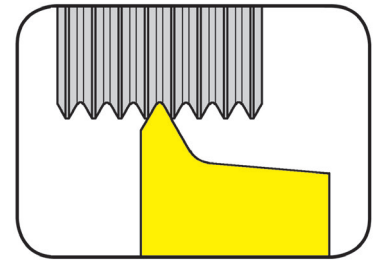

for Toolholder

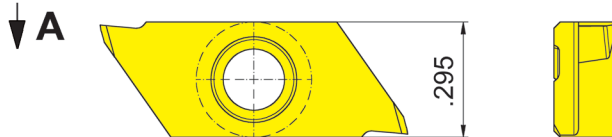

Type H274/HU274
KT274
KTC274
974
76
H274KM
HC274KM

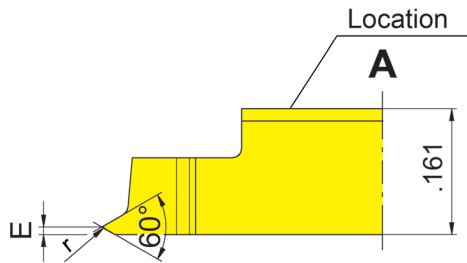

R = right hand version shown

Indexability length ± .0006"

Part number	P TPI	E	r	Size	IG35
RSU274.1220.01	12 - 20	.052	.007	04	x
RSU274.1832.01	18 - 32	.039	.005	04	x
RSU274.2864.01	28 - 64	.028	.002	04	x

▲ on stock Δ 4 weeks x upon request

- recommended
- alternative recommendation
- not suitable

- uncoated grades
- coated grades
- brazed/Cermet

Dimensions in inch

P	-
M	•
K	-
N	-
S	•
H	-

Carbide grades

No shims necessary. All HORN thread profiles are manufactured with **fully ground radial clearance**.



Threading (external) Partial profile



Indexable insert

S274

Metric ISO - thread

Pitch	0.25 - 0.40 mm
-------	----------------

precision ground

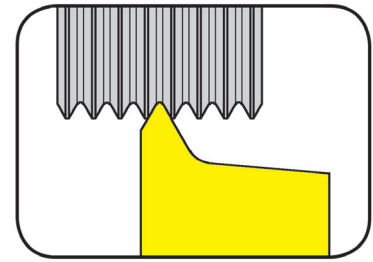

for Toolholder

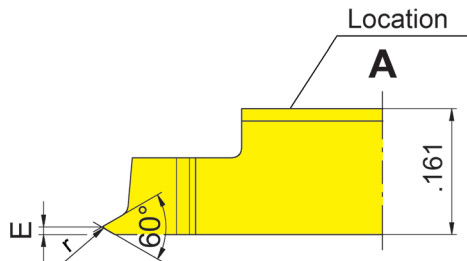
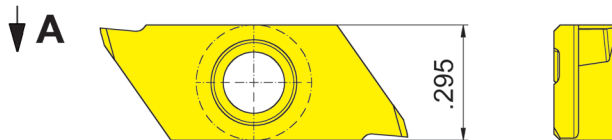

Type H274/HU274
KT274
KTC274
974
76
H274KM
HC274KM

Indexability length \pm
.0006"

R = right hand version shown

Part number	P mm	E	r	Size	Carbide grades	
					IG35	TH35
RS274.0102.01	0.25	.008	.002	04	▲	▲
RS274.0203.01	0.35	.010	.002	04	▲	▲
RS274.0204.01	0.40	.012	.002	04	▲	▲
					P	•
					M	•
					K	•
					N	•
					S	•
					H	-

▲ on stock Δ 4 weeks x upon request

- recommended
- alternative recommendation
- not suitable

- uncoated grades
- coated grades
- brazed/Cermet

Dimensions in inch

Carbide grades

No shims necessary. All HORN thread profiles are manufactured with **fully ground radial clearance**.



Threading (external) Full profile



Indexable insert

S274

Metric ISO - thread

Pitch	0.50 - 1.5 mm
-------	---------------

precision ground

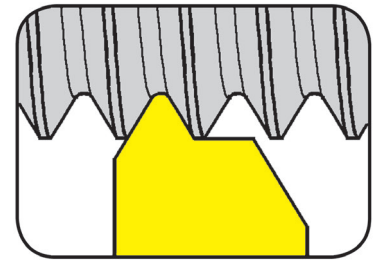

for Toolholder

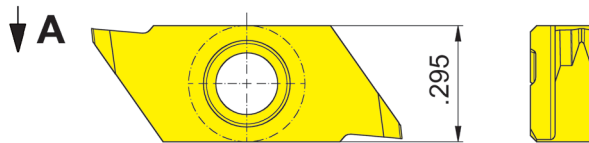

Type H274/HU274
KT274
KTC274
974
76
H274KM
HC274KM

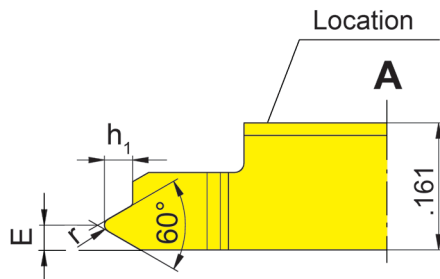

R = right hand version shown

L = left hand version

Indexability length ± .0006"

Part number	P mm	E	r	h ₁	Size	IG35	TH35
R/LS274.0305.02	0.50	.016	.003	.012	04	▲/▲	▲/▲
R/LS274.0306.02	0.60	.018	.004	.015	04	▲/▲	▲/▲
R/LS274.0307.02	0.70	.020	.004	.017	04	▲/▲	▲/▲
R/LS274.0407.02	0.75	.020	.004	.018	04	▲/▲	▲/▲
R/LS274.0408.02	0.80	.022	.005	.019	04	▲/▲	▲/▲
R/LS274.0610.02	1.00	.024	.006	.024	04	▲/▲	▲/▲
R/LS274.0712.02	1.25	.028	.006	.030	04	▲/▲	▲/▲
R/LS274.0915.02	1.50	.031	.008	.036	04	▲/▲	▲/▲

- ▲ on stock Δ 4 weeks x upon request
- recommended
- o alternative recommendation
- not suitable
- uncoated grades
- coated grades
- brazed/Cermet

Dimensions in inch

State R or L version

No shims necessary. All HORN thread profiles are manufactured with **fully ground radial clearance**.

	P	M	K	N	S	H
IG35	-	●	-	-	-	-
TH35	●	●	●	●	●	●

Carbide grades



Threading (external) Full profile



Indexable insert

S274

Metric ISO - thread

Pitch	0.5 - 1.5 mm
-------	--------------

precision ground

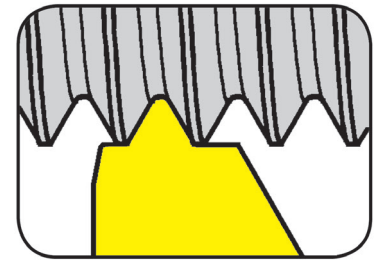

for Toolholder

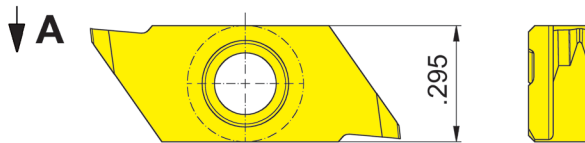

Type H274/HU274
KT274
KTC274
974
76
H274KM
HC274KM

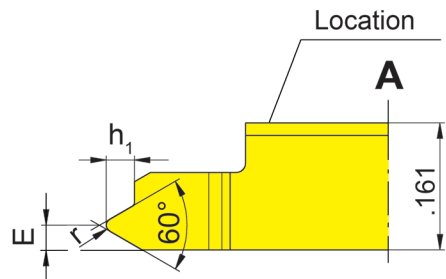

R = right hand version shown

L = left hand version

Indexability length \pm .0006"

Part number	P mm	E	r	h ₁	Size	IG35	TH35
R/LS274.0305.03	0.50	.016	.003	.012	04	Δ/Δ	▲/▲
R/LS274.0306.03	0.60	.018	.004	.015	04	Δ/Δ	Δ/Δ
R/LS274.0307.03	0.70	.020	.004	.017	04	Δ/Δ	▲/Δ
R/LS274.0407.03	0.75	.020	.004	.018	04	Δ/Δ	Δ/Δ
R/LS274.0408.03	0.80	.022	.005	.019	04	Δ/Δ	Δ/Δ
R/LS274.0610.03	1.00	.024	.006	.024	04	▲/Δ	▲/Δ
R/LS274.0712.03	1.25	.028	.006	.030	04	Δ/Δ	Δ/Δ
R/LS274.0915.03	1.50	.031	.008	.036	04	Δ/Δ	▲/Δ

- ▲ on stock Δ 4 weeks x upon request
- recommended
- alternative recommendation
- not suitable
- uncoated grades
- coated grades
- brazed/Cermet

Dimensions in inch

State R or L version

No shims necessary. All HORN thread profiles are manufactured with **fully ground radial clearance**.

	IG35	TH35
P	-	●
M	●	●
K	-	●
N	-	●
S	●	●
H	-	-

Carbide grades



Toolholder

HU274...E

Depth of groove	.236"
Width of groove	.020 - .118"

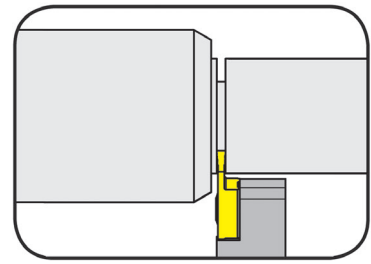

for Indexable insert

Type S274...E

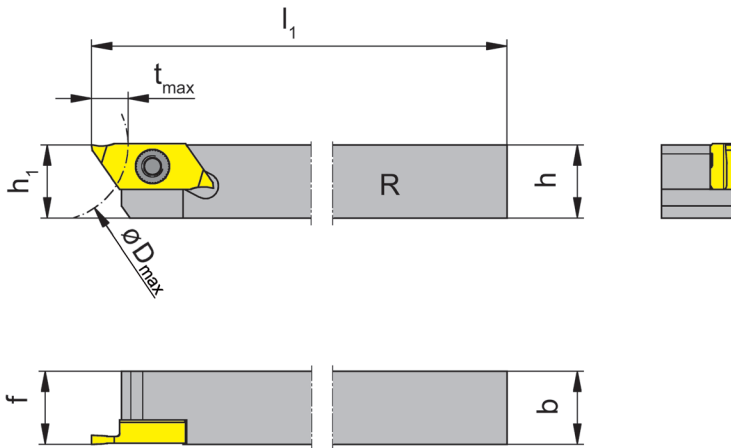

R = right hand version shown

L = left hand version

Part number	h	b	l ₁	h ₁	f	t _{max}	D _{max}	Size
RHU274.0500.04.E	.500	.500	3.996	.500	.500	.236	.984	04

State R or L version

Dimensions in inch

Further sizes upon request

For torque specification of the screw, please see Technical Instructions.

Spare Parts

Toolholder	Clamping Screw	TORX PLUS® Wrench
RHU274.0500.04.E	030.3509.T15P	T15PQ



Toolholder

H274...E

Depth of groove
Width of groove

6 mm
0.5 - 3 mm

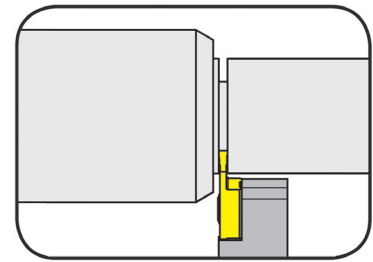

for Indexable insert

Type S274...E

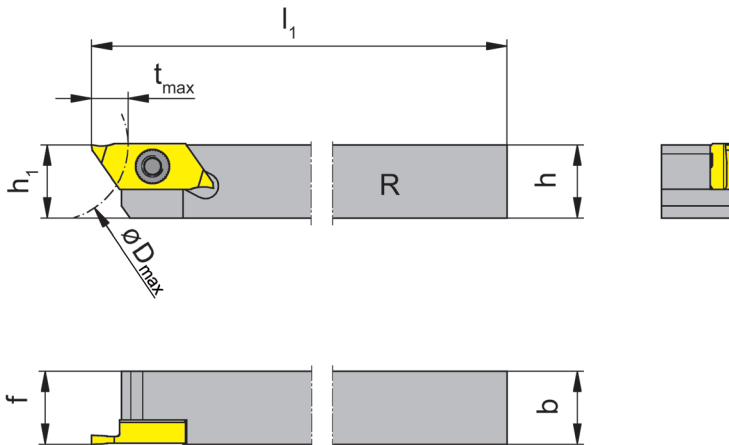

R = right hand version shown

L = left hand version

Part number	h	b	l ₁	h ₁	f	t _{max}	D _{max}	Size
R/LH274.1010.04.E	10	10	100	10	10	6	25	04
R/LH274.1212.04.E	12	12	100	12	12	6	25	04
R/LH274.1616.04.E	16	16	125	16	16	6	25	04
R/LH274.2020.04.E	20	20	125	20	20	6	25	04

State R or L version

Dimensions in mm

Further sizes upon request

For torque specification of the screw, please see Technical Instructions.

L

Spare Parts

Toolholder	Clamping Screw	TORX PLUS® Wrench
R/LH274...	030.3509.T15P	T15PQ

Indexable insert

S274...E

Depth of groove up to .177"
Width of groove .059 - .118"

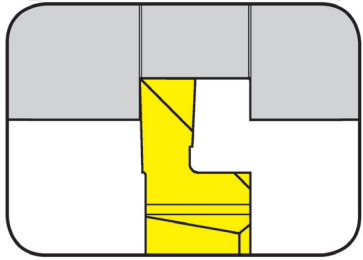

precision ground

for Toolholder

Type H274...E

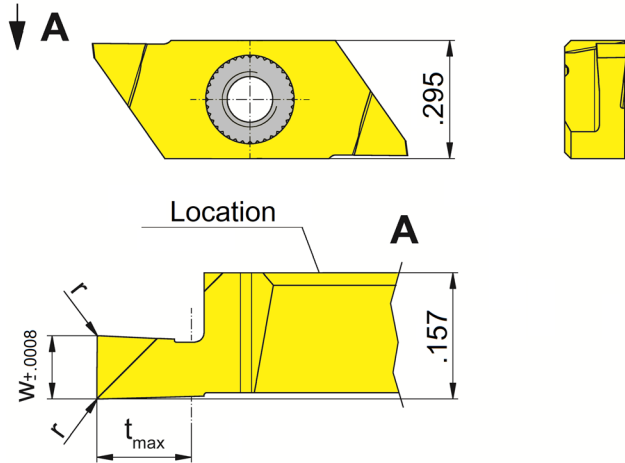

R = right hand version shown

L = left hand version

Indexability length ± .0006"

Part number	w	r	t _{max}	Size	IG35	TH35
R/LS274.0150.P0.E	.059	.002	.089	04	ΔΔ	ΔΔ
R/LS274.0200.P0.E	.079	.002	.118	04	ΔΔ	ΔΔ
R/LS274.0250.P0.E	.098	.004	.148	04	ΔΔ	ΔΔ
R/LS274.0300.P0.E	.118	.004	.177	04	ΔΔ	ΔΔ

▲ on stock Δ 4 weeks x upon request

- recommended
- alternative recommendation
- not suitable

- uncoated grades
- coated grades
- brazed/Cermet

Dimensions in inch

State R or L version

	IG35	TH35
P	-	●
M	●	●
K	-	●
N	-	●
S	●	●
H	-	-

Carbide grades



Indexable insert

S274...E

Depth of groove up to $.157''$
Full radius $.010 - .039''$

precision ground

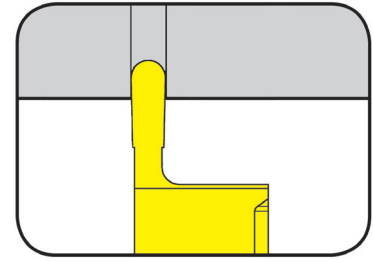

for Toolholder

Type H274...E

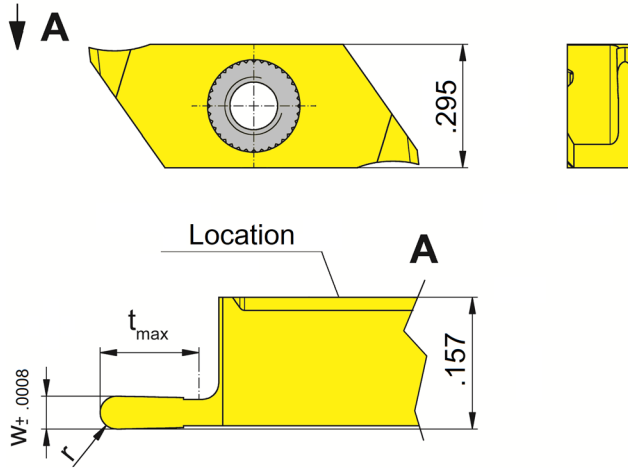

R = right hand version shown

L = left hand version

Indexability length $\pm .0006''$

Part number	w	t _{max}	r	Size	IG35	TH35
R/LS274.0205.01.10.E	.020	.059	.010	04	Δ/Δ	Δ/Δ
R/LS274.0510.03.10.E	.039	.118	.020	04	Δ/Δ	Δ/▲
R/LS274.1020.04.10.E	.079	.157	.039	04	Δ/Δ	Δ/Δ

▲ on stock Δ 4 weeks x upon request

- recommended
- alternative recommendation
- not suitable

- uncoated grades
- coated grades
- brazed/Cermet

Dimensions in inch

State R or L version

	IG35	TH35
P	-	●
M	●	●
K	-	●
N	-	●
S	●	●
H	-	-

Carbide grades



Indexable insert

S274...E

Depth of groove up to $.236''$
 Width of groove $.020 - .079''$

precision ground

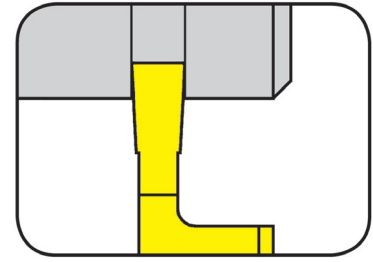

for Toolholder

Type H274...E

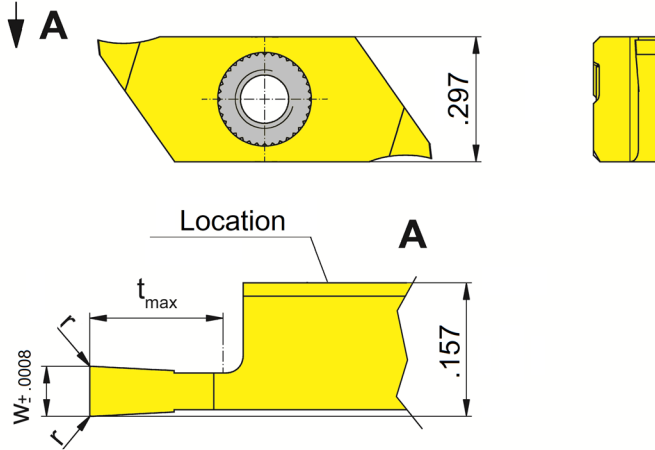

R = right hand version shown

L = left hand version

Indexability length $\pm .0006''$

Part number	w	r	t _{max}	Size	IG35	TH35
R/LS274.0120.03.10.E	.047	.002	.118	04	ΔΔ	ΔΔ
R/LS274.0050.01.10.E	.020	.002	.059	04	ΔΔ	ΔΔ
R/LS274.0070.02.10.E	.028	.002	.079	04	ΔΔ	ΔΔ
R/LS274.0080.03.10.E	.031	.002	.118	04	ΔΔ	ΔΔ
R/LS274.0100.03.10.E	.039	.002	.118	04	Δx	ΔΔ
R/LS274.0150.04.10.E	.059	.002	.157	04	ΔΔ	ΔΔ
R/LS274.0150.06.10.E	.059	.002	.236	04	ΔΔ	ΔΔ
R/LS274.0200.04.10.E	.079	.002	.157	04	ΔΔ	ΔΔ
R/LS274.0200.06.10.E	.079	.002	.236	04	ΔΔ	ΔΔ

▲ on stock Δ 4 weeks x upon request

- recommended
- alternative recommendation
- not suitable

- uncoated grades
- coated grades
- brazed/Cermet

Dimensions in inch

State R or L version

	IG35	TH35
P	-	•
M	•	•
K	-	•
N	-	•
S	•	•
H	-	-

Carbide grades



Indexable insert

S274...E

Depth of groove up to	.236"
Width of groove	.020 - .079"

precision ground

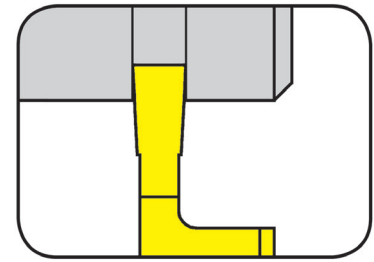

for Toolholder

Type H274...E

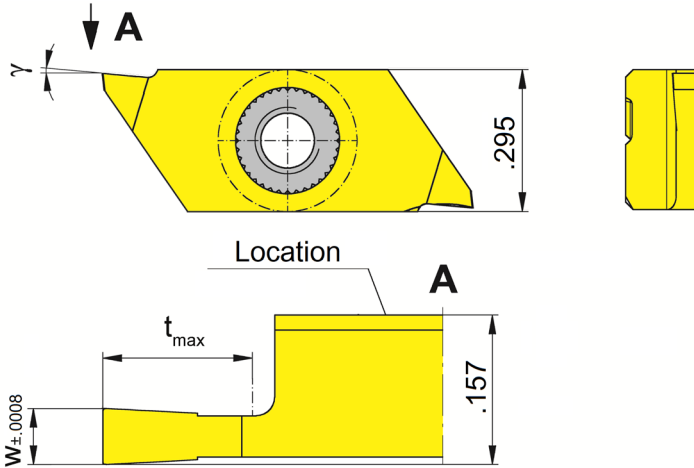

R = right hand version shown

L = left hand version

Indexability length ± .0006"

Part number	w	t _{max}	γ	Size	IG35	TH35
R/LS274.0050.01.20.E	.020	.059	5°	04	ΔΔ	ΔΔ
R/LS274.0070.02.20.E	.028	.079	5°	04	ΔΔ	ΔΔ
R/LS274.0080.03.20.E	.031	.118	5°	04	ΔΔ	ΔΔ
R/LS274.0100.03.20.E	.039	.118	5°	04	ΔΔ	ΔΔ
R/LS274.0120.03.20.E	.047	.118	5°	04	ΔΔ	ΔΔ
R/LS274.0150.04.20.E	.059	.157	5°	04	ΔΔ	ΔΔ
R/LS274.0150.06.20.E	.059	.236	5°	04	ΔΔ	ΔΔ
R/LS274.0200.04.20.E	.079	.157	5°	04	ΔΔ	ΔΔ
R/LS274.0200.06.20.E	.079	.236	5°	04	ΔΔ	ΔΔ

▲ on stock Δ 4 weeks x upon request

- recommended
- alternative recommendation
- not suitable

- uncoated grades
- coated grades
- brazed/Cermet

Dimensions in inch

State R or L version

	IG35	TH35
P	-	•
M	•	•
K	-	•
N	-	•
S	•	•
H	-	-

Carbide grades



Indexable insert

S274...E

Depth of groove up to	.236"
Width of groove	.020 - .079"

precision ground

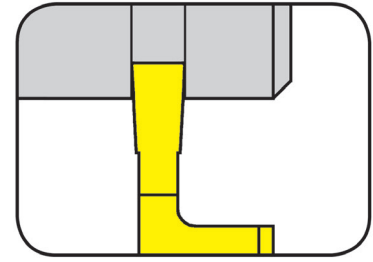

for Toolholder

Type H274...E

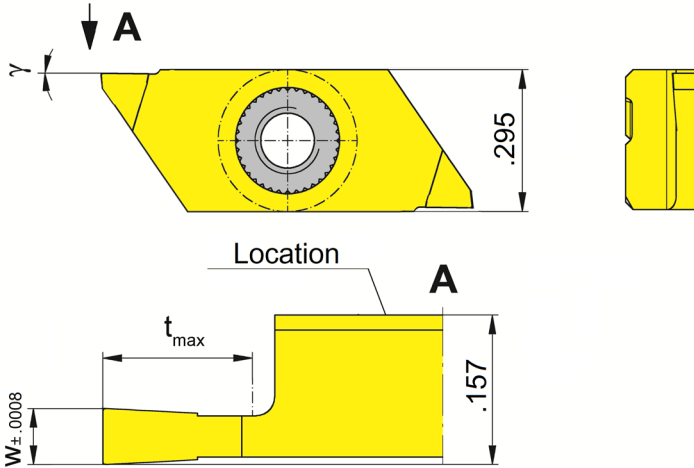

R = right hand version shown

L = left hand version

Indexability length \pm .0006"

Part number	w	t _{max}	γ	Size	IG35	TH35
R/LS274.0050.01.M0.E	.020	.059	0°	04	ΔΔ	ΔΔ
R/LS274.0070.02.M0.E	.028	.079	0°	04	ΔΔ	ΔΔ
R/LS274.0080.03.M0.E	.031	.118	0°	04	ΔΔ	ΔΔ
R/LS274.0100.03.M0.E	.039	.118	0°	04	ΔΔ	ΔΔ
R/LS274.0120.03.M0.E	.047	.118	0°	04	ΔΔ	ΔΔ
R/LS274.0150.04.M0.E	.059	.157	0°	04	ΔΔ	ΔΔ
R/LS274.0150.06.M0.E	.059	.236	0°	04	ΔΔ	ΔΔ
R/LS274.0200.04.M0.E	.079	.157	0°	04	ΔΔ	ΔΔ
R/LS274.0200.06.M0.E	.079	.236	0°	04	ΔΔ	ΔΔ

▲ on stock Δ 4 weeks x upon request

- recommended
- alternative recommendation
- not suitable

- uncoated grades
- coated grades
- brazed/Cermet

Dimensions in inch

State R or L version

	IG35	TH35
P	-	•
M	•	•
K	-	•
N	-	•
S	•	•
H	-	-

Carbide grades



Indexable insert

S274...E

Depth of cut up to .236"

precision ground

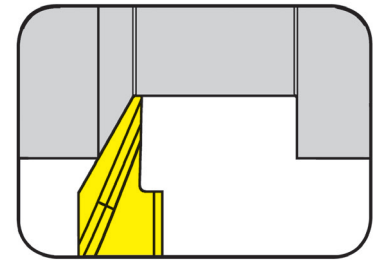

for Toolholder

Type H274...E

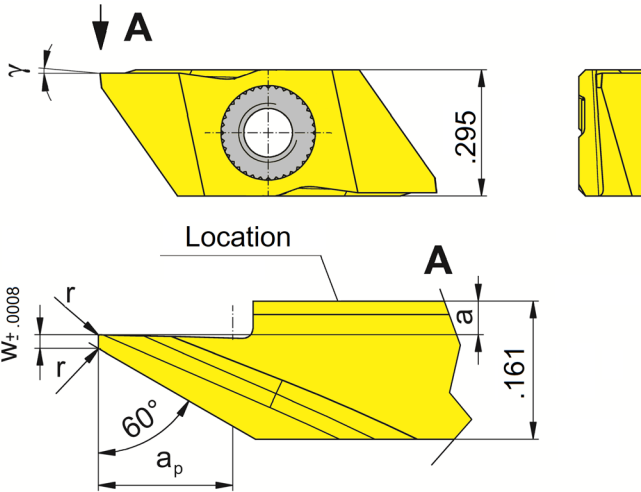

R = right hand version shown

L = left hand version

Indexability length \pm .0006"

Part number	w	r	a	γ	a_p	Size	K10	IG35	TH35
R/LS274.0060.04.10.E	-	.002	.039	15°	.157	04		Δ/Δ	Δ/Δ
R/LS274.0460.04.10.E	.016	.002	.039	15°	.157	04		Δ/Δ	Δ/Δ
R/LS274.0460.04.M0.E	.016	.002	.039	0°	.157	04	Δ/Δ	Δ/Δ	x/x
R/LS274.0560.06.11.E	.020	.004	.002	15°	.236	04		Δ/Δ	Δ/Δ

▲ on stock Δ 4 weeks x upon request
 ● recommended
 ○ alternative recommendation
 - not suitable

□ uncoated grades
 ■ coated grades
 ■ brazed/Cermet

Dimensions in inch

State R or L version

	P	M	K	N	S	H
K10	●	○	●	●	○	-
IG35	-	●	-	-	●	-
TH35	●	●	●	●	●	-

Carbide grades



Indexable insert

S274...E

Depth of cut up to .236"

precision ground

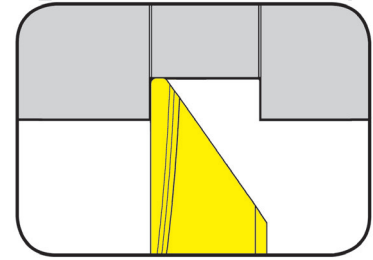

for Toolholder

Type H274...E

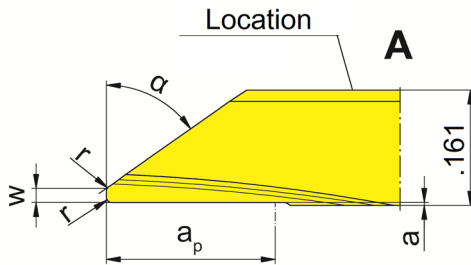
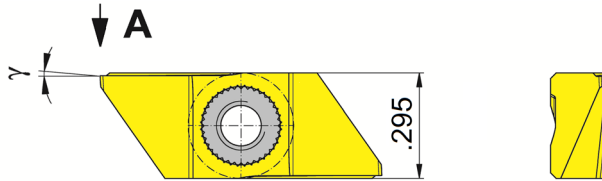

R = right hand version shown

L = left hand version

Indexability length ± .0006"

Part number	w	r	a	γ	a _p	α	Size	IG35	TH35
R/LS274.0035.04.20.E	-	.002	.004	5°	.157	35°	04	Δ/Δ	Δ/Δ
R/LS274.0235.04.20.E	.008	-	.004	5°	.157	35°	04	Δ/Δ	Δ/Δ
R/LS274.0535.06.20.E	.020	.008	.004	5°	.236	35°	04	Δ/Δ	Δ/Δ
R/LS274.0055.04.20.E	-	.002	.004	5°	.157	55°	04	Δ/Δ	Δ/Δ
R/LS274.0255.04.20.E	.008	-	.004	5°	.157	55°	04	Δ/Δ	Δ/Δ
R/LS274.0555.06.20.E	.020	.008	.004	5°	.236	55°	04	Δ/Δ	Δ/Δ

▲ on stock Δ 4 weeks x upon request

- recommended
- alternative recommendation
- not suitable

- uncoated grades
- coated grades
- brazed/Cermet

Dimensions in inch

State R or L version

	P	M	K	N	S	H
IG35	-	●	-	-	●	-
TH35	●	●	●	●	●	-

Carbide grades



Indexable insert

S274...E

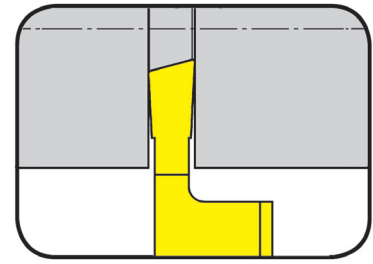

Depth of groove up to $.236''$
 Width of groove $.031 - .079''$

precision ground

for Toolholder

Type H274...E

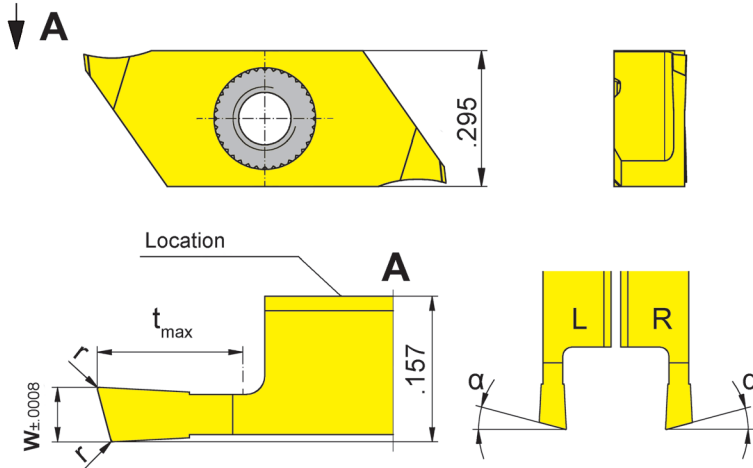

R = right hand version shown

L = left hand version

Indexability length $\pm .0006''$

Part number	w	r	t _{max}	α	Size	IG35	TH35
R/LS274.1508.03.10.E	.031	.002	.118	15°	04	ΔΔ	ΔΔ
R/LS274.1510.03.10.E	.039	.002	.118	15°	04	ΔΔ	ΔΔ
R/LS274.1515.04.10.E	.059	.002	.157	15°	04	ΔΔ	ΔΔ
R/LS274.1520.06.10.E	.079	.002	.236	15°	04	ΔΔ	ΔΔ

▲ on stock Δ 4 weeks x upon request

- recommended
- alternative recommendation
- not suitable

- uncoated grades
- coated grades
- brazed/Cermet

Dimensions in inch

State R or L version

Note:

t_{max} .236" can be reached only with workpiece $\varnothing \leq .984''$.

	IG35	TH35
P	-	•
M	•	•
K	-	•
N	-	•
S	•	•
H	-	-

Carbide grades



Indexable insert

S274...E

Depth of groove up to $.236''$
 Width of groove $.031 - .079''$

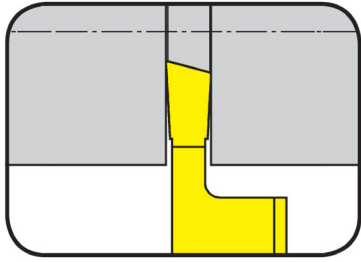

precision ground

for Toolholder

Type H274...E

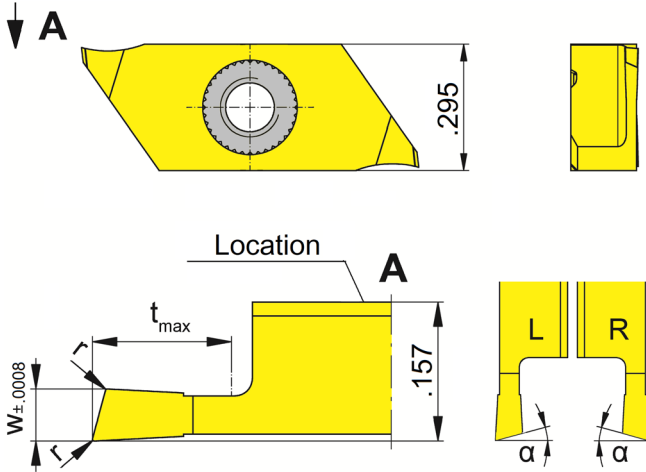

R = right hand version shown

L = left hand version

Indexability length $\pm .0006''$

Part number	w	r	t _{max}	α	Size	IG35	TH35
LS274.1508.03.1R.E	.031	.002	.118	15°	04	Δ	Δ
LS274.1510.03.1R.E	.039	.002	.118	15°	04	Δ	Δ
LS274.1515.04.1R.E	.059	.002	.157	15°	04	Δ	Δ
LS274.1520.06.1R.E	.079	.002	.236	15°	04	Δ	Δ
RS274.1508.03.1L.E	.031	.002	.118	15°	04	Δ	Δ
RS274.1510.03.1L.E	.039	.002	.118	15°	04	Δ	Δ
RS274.1515.04.1L.E	.059	.002	.157	15°	04	Δ	Δ
RS274.1520.06.1L.E	.079	.002	.236	15°	04	Δ	Δ

- ▲ on stock Δ 4 weeks x upon request
- recommended
- o alternative recommendation
- not suitable
- uncoated grades
- coated grades
- brazed/Cermet

Dimensions in inch

	P	M	K	N	S	H
IG35	-	●	-	-	●	-
TH35	●	●	●	●	●	-

Carbide grades

Note:

t_{max} $.236''$ can be reached only with workpiece $\varnothing \leq .984''$.



Indexable insert

S274...E

Depth of groove up to $.236''$
 Width of groove $.059 - .079''$

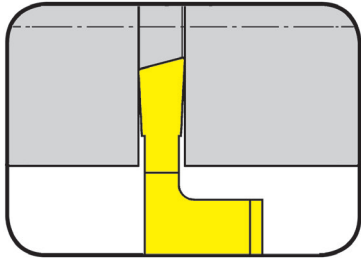

precision ground

for Toolholder

Type H274...E

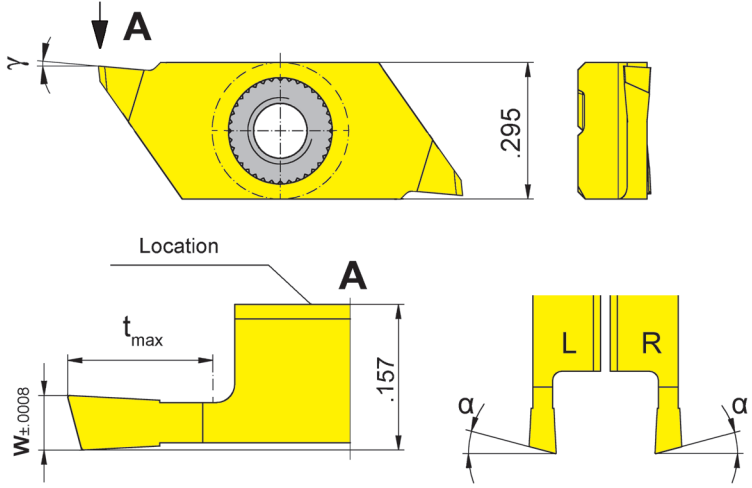

R = right hand version shown

L = left hand version

Indexability length $\pm .0006''$

Part number	w	t _{max}	α	γ	Size	IG35	TH35
R/LS274.1515.04.20.E	.059	.157	15°	5°	04	Δ/Δ	Δ/Δ
R/LS274.1520.06.20.E	.079	.236	15°	5°	04	Δ/Δ	Δ/Δ

- ▲ on stock Δ 4 weeks x upon request
 - recommended
 - o alternative recommendation
 - not suitable
 - uncoated grades
 - coated grades
 - brazed/Cermet
- Dimensions in inch

	IG35	TH35
P	-	●
M	●	●
K	-	●
N	-	●
S	●	●
H	-	-

Carbide grades

State R or L version

Note:

t_{max} .236'' can be reached only with workpiece $\varnothing \leq .984''$.



Indexable insert

S274...E

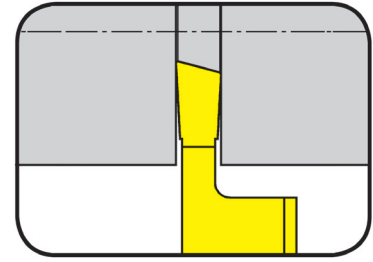

Depth of groove up to $.236''$
 Width of groove $.059 - .079''$

precision ground

for Toolholder

Type H274...E

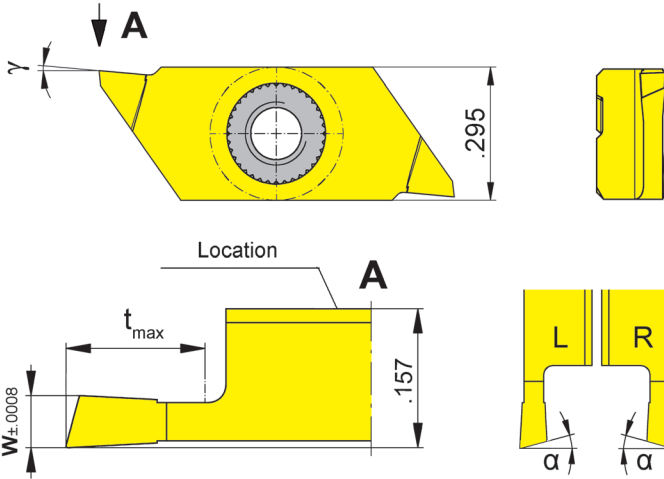

R = right hand version shown

L = left hand version

Indexability length $\pm .0006''$

Part number	w	t _{max}	α	γ	Size	IG35	TH35
LS274.1515.04.2R.E	.059	.157	15°	5°	04	Δ	Δ
LS274.1520.06.2R.E	.079	.236	15°	5°	04	Δ	Δ
RS274.1515.04.2L.E	.059	.157	15°	5°	04	Δ	Δ
RS274.1520.06.2L.E	.079	.236	15°	5°	04	Δ	Δ

▲ on stock Δ 4 weeks x upon request

- recommended
- alternative recommendation
- not suitable

- uncoated grades
- coated grades
- brazed/Cermet

Dimensions in inch

	IG35	TH35
P	-	●
M	●	●
K	-	●
N	-	●
S	●	●
H	-	-

Carbide grades

Note:

t_{max} .236'' can be reached only with workpiece $\varnothing \leq .984''$.



Indexable insert

S274...E

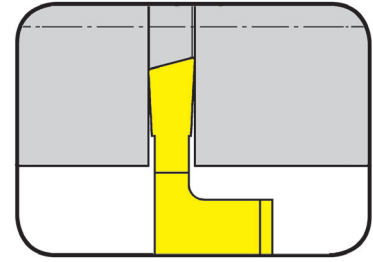

Depth of groove up to $.236''$
 Width of groove $.031 - .079''$

precision ground

for Toolholder

Type H274...E

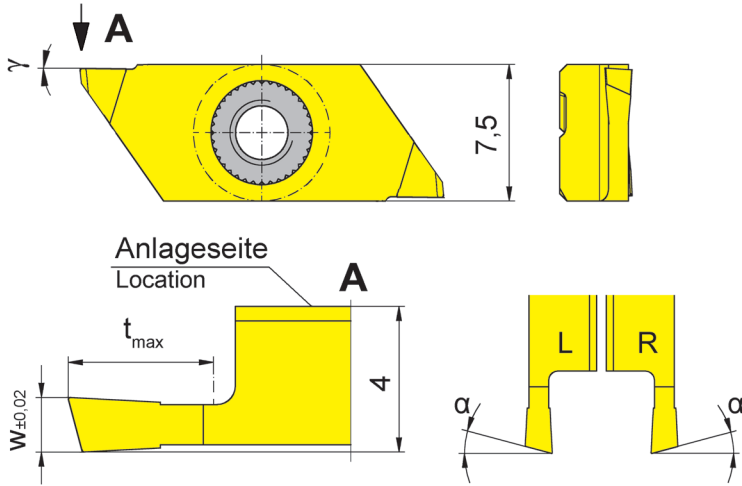

R = right hand version shown

L = left hand version

Indexability length $\pm .0006''$

Part number	w	t _{max}	α	γ	Size	IG35	TH35
R/LS274.1508.03.M0.E	.031	.118	15°	0°	04	ΔΔ	ΔΔ
R/LS274.1510.03.M0.E	.039	.118	15°	0°	04	ΔΔ	ΔΔ
R/LS274.1515.04.M0.E	.059	.157	15°	0°	04	ΔΔ	ΔΔ
R/LS274.1520.06.M0.E	.079	.236	15°	0°	04	ΔΔ	ΔΔ

▲ on stock Δ 4 weeks x upon request

- recommended
- alternative recommendation
- not suitable

- uncoated grades
- coated grades
- brazed/Cermet

Dimensions in inch

State R or L version

Note:

t_{max} $.236''$ can be reached only with workpiece $\varnothing \leq .984''$.

	IG35	TH35
P	-	●
M	●	●
K	-	●
N	-	●
S	●	●
H	-	-

Carbide grades



Indexable insert

S274...E

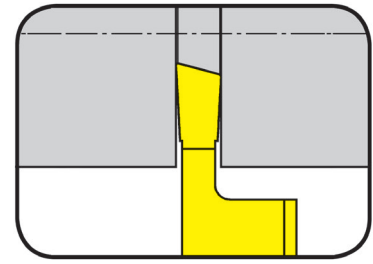

Depth of groove up to $.236''$
 Width of groove $.031 - .079''$

precision ground

for Toolholder

Type H274...E

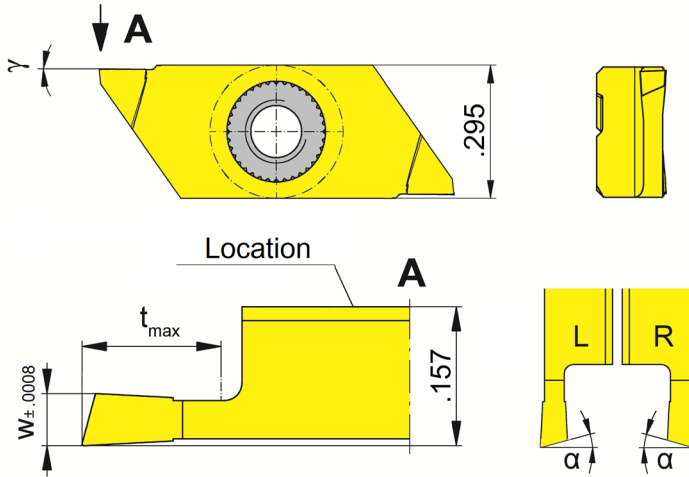

R = right hand version shown

L = left hand version

Indexability length $\pm .0006''$

Part number	w	t _{max}	α	γ	Size	Carbide grades	
						IG35	TH35
LS274.1508.03.MR.E	.031	.118	15°	0°	04	Δ	Δ
LS274.1510.03.MR.E	.039	.118	15°	0°	04	Δ	Δ
LS274.1515.04.MR.E	.059	.157	15°	0°	04	Δ	Δ
LS274.1520.06.MR.E	.079	.236	15°	0°	04	Δ	Δ
RS274.1508.03.ML.E	.031	.118	15°	0°	04	Δ	Δ
RS274.1510.03.ML.E	.039	.118	15°	0°	04	Δ	Δ
RS274.1515.04.ML.E	.059	.157	15°	0°	04	Δ	Δ
RS274.1520.06.ML.E	.079	.236	15°	0°	04	Δ	Δ

- ▲ on stock Δ 4 weeks x upon request
- recommended
- alternative recommendation
- not suitable
- uncoated grades
- coated grades
- brazed/Cermet

Dimensions in inch

	IG35	TH35
P	-	●
M	●	●
K	-	●
N	-	●
S	●	●
H	-	-

Carbide grades

Note:

t_{max} .236'' can be reached only with workpiece Ø ≤ .984''.



Threading (external) Partial profile



Indexable insert

SU274...E

Pitch	12 - 64 TPI
-------	-------------

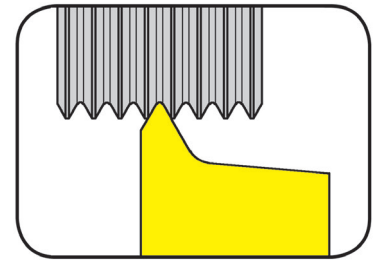

precision ground

for Toolholder

Type H274...E

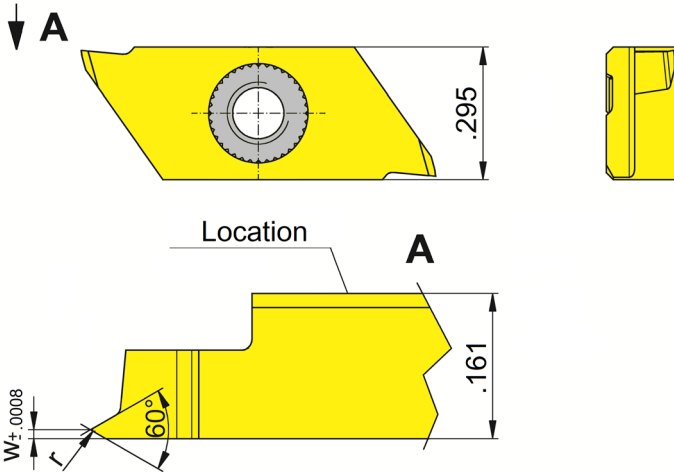

R = right hand version shown

Indexability length ± .0006"

Part number	P TPI	E	r	Size	IG35
RSU274.1220.01.E	12 - 20	.052	.007	04	x
RSU274.1832.01.E	18 - 32	.039	.005	04	x
RSU274.2864.01.E	28 - 64	.028	.002	04	x

▲ on stock Δ 4 weeks x upon request

- recommended
- alternative recommendation
- not suitable

- uncoated grades
- coated grades
- brazed/Cermet

Dimensions in inch

P	-
M	•
K	-
N	-
S	•
H	-

Carbide grades

No shims necessary. All HORN thread profiles are manufactured with **full ground radial clearance**.



Threading (external) Partial profile



Indexable insert

S274...E

Metric ISO - thread

Pitch	0.25 - 0.40 mm
-------	----------------

precision ground

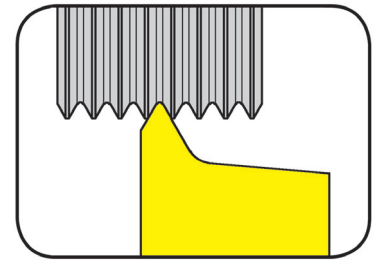

for Toolholder

Type H274...E

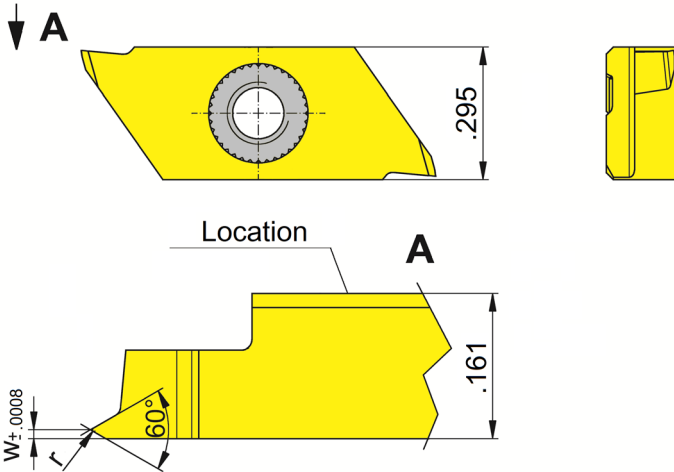

R = right hand version shown

Indexability length \pm .0006"

Part number	P mm	E	r	Size	Carbide grades	
					IG35	TH35
RS274.0102.01.E	0.25	.008	.002	04	Δ	Δ
RS274.0203.01.E	0.35	.010	.002	04	Δ	Δ
RS274.0204.01.E	0.40	.012	.002	04	Δ	Δ
					P	•
					M	•
					K	•
					N	•
					S	•
					H	-

▲ on stock Δ 4 weeks x upon request

- recommended
- alternative recommendation
- not suitable

- uncoated grades
- coated grades
- brazed/Cermet

Dimensions in inch

Carbide grades

No shims necessary. All HORN thread profiles are manufactured with **full ground radial clearance**.



Threading (external) Full profile



Indexable insert

S274...E

Metric ISO - thread

Pitch	0.50 - 1.5 mm
-------	---------------

precision ground

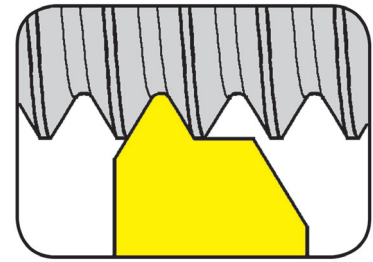

for Toolholder

Type H274...E

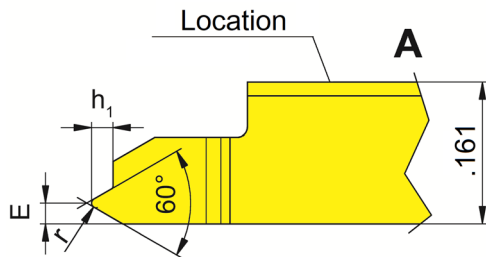
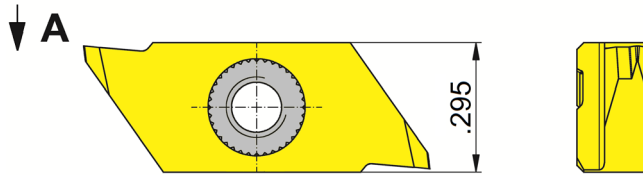

R = right hand version shown

L = left hand version

Indexability length \pm .0006"

Part number	P mm	E	r	h ₁	Size	IG35	TH35
R/LS274.0305.02.E	0.50	.016	.003	.012	04	ΔΔ	ΔΔ
R/LS274.0306.02.E	0.60	.018	.004	.015	04	ΔΔ	ΔΔ
R/LS274.0307.02.E	0.70	.020	.004	.017	04	ΔΔ	ΔΔ
R/LS274.0407.02.E	0.75	.020	.004	.018	04	ΔΔ	ΔΔ
R/LS274.0408.02.E	0.80	.022	.005	.019	04	ΔΔ	ΔΔ
R/LS274.0610.02.E	1.00	.024	.006	.024	04	ΔΔ	ΔΔ
R/LS274.0712.02.E	1.25	.028	.006	.030	04	ΔΔ	ΔΔ
R/LS274.0915.02.E	1.50	.031	.008	.036	04	ΔΔ	ΔΔ

- ▲ on stock Δ 4 weeks x upon request
- recommended
- o alternative recommendation
- not suitable
- uncoated grades
- coated grades
- brazed/Cermet

Dimensions in inch

State R or L version

No shims necessary. All HORN thread profiles are manufactured with **full ground radial clearance**.

	P	M	K	N	S	H
IG35	-	●	-	-	●	-
TH35	●	●	●	●	●	-

Carbide grades



Threading (external) Full profile



Indexable insert

S274...E

Metric ISO - thread

Pitch	0.50 - 1.5 mm
-------	---------------

precision ground

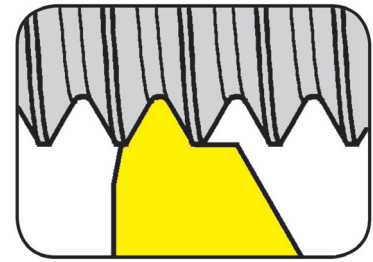

for Toolholder

Type H274...E

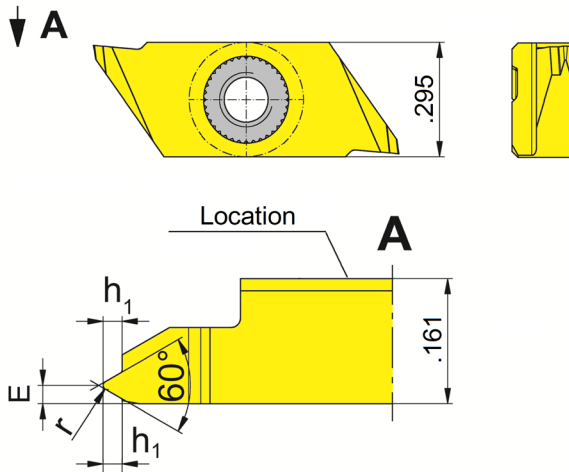

R = right hand version shown

L = left hand version

Indexability length \pm .0006"

Part number	P mm	E	r	h ₁	Size	IG35	TH35
R/LS274.0305.03.E	0.50	.016	.003	.012	04	ΔΔ	ΔΔ
R/LS274.0306.03.E	0.60	.018	.004	.015	04	ΔΔ	ΔΔ
R/LS274.0307.03.E	0.70	.020	.004	.017	04	ΔΔ	ΔΔ
R/LS274.0407.03.E	0.75	.020	.004	.018	04	ΔΔ	ΔΔ
R/LS274.0408.03.E	0.80	.022	.005	.019	04	ΔΔ	ΔΔ
R/LS274.0610.03.E	1.00	.024	.006	.024	04	ΔΔ	ΔΔ
R/LS274.0712.03.E	1.25	.028	.006	.030	04	ΔΔ	ΔΔ
R/LS274.0915.03.E	1.50	.031	.008	.036	04	ΔΔ	ΔΔ

- ▲ on stock Δ 4 weeks x upon request
- recommended
- alternative recommendation
- not suitable
- uncoated grades
- coated grades
- brazed/Cermet

Dimensions in inch

State R or L version

No shims necessary. All HORN thread profiles are manufactured with **full ground radial clearance**.

	P	M	K	N	S	H
IG35	-	•	-	-	•	-
TH35	•	•	•	•	•	-

Carbide grades



Toolholder

H274...SF

Depth of groove up to
Width of groove

6 mm
0.5 - 2 mm

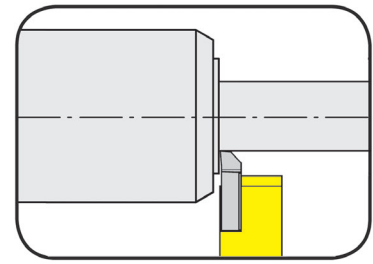

for Toolholder

Type S274...SF

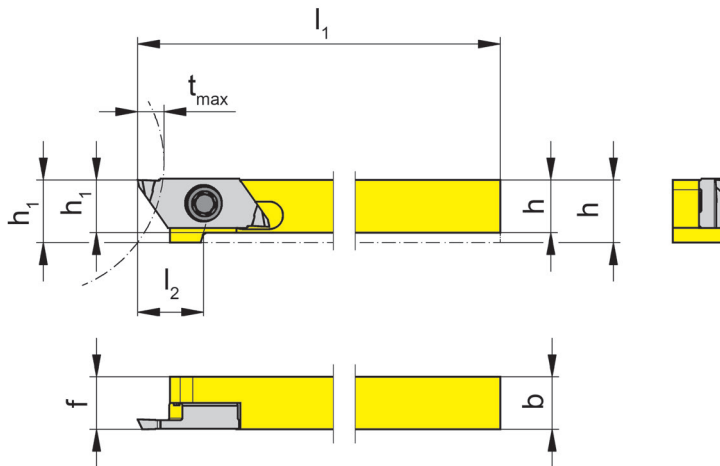

R = right hand version shown

L = left hand version

Part number	h	b	l ₁	l ₂	h ₁	f	t _{max}	Size
R/LH274.0808.SF.04	8	8	100	10	9.5	8	6	04
R/LH274.1010.SF.04	10	10	100	-	10.0	10	6	04
R/LH274.1212.SF.04	12	12	100	-	12.0	12	6	04

Further sizes upon request

Dimensions in mm

t_{max} 6 mm can be reached only with workpiece Ø ≤ 25 mm.

For torque specification of the screw, please see Technical Instructions.

L

Spare Parts

Toolholder	Clamping Screw	TORX PLUS® Wrench
RH274...	030.350P.0852	T15PQ

Toolholder

H274...SF

Depth of groove 6 mm
Width of groove 0.5 - 2 mm

Material of shank: tungsten alloy (giving good vibration resistance)

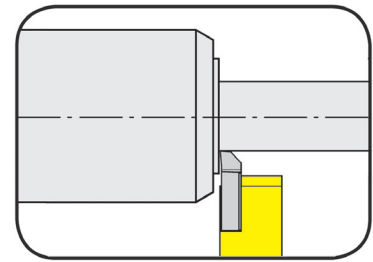

for Toolholder

Type S274...SF

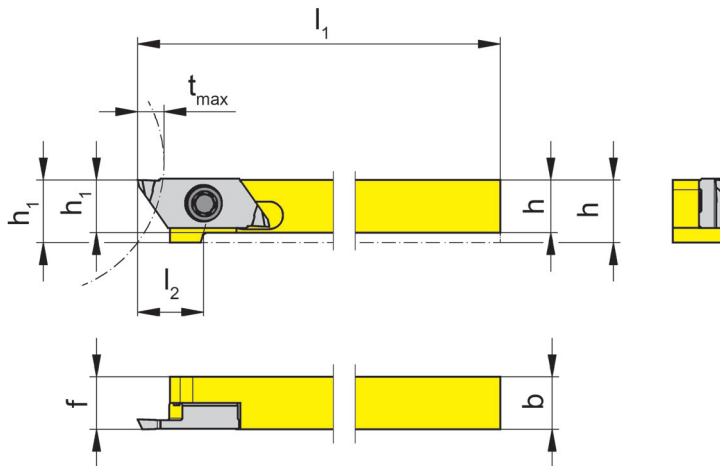

R = right hand version shown

L = left hand version

Part number	h	b	l ₁	l ₂	h ₁	f	t _{max}	Size
R/LH274.0808.SF.S4	8	8	100	10	9.5	8	6	04
R/LH274.1010.SF.S4	10	10	100	-	10.0	10	6	04
R/LH274.1212.SF.S4	12	12	100	-	12.0	12	6	04

Further sizes upon request

Dimensions in mm

t_{max} 6 mm can be reached only with workpiece Ø ≤ 25 mm.

For torque specification of the screw, please see Technical Instructions.

Spare Parts

Toolholder	Clamping Screw	TORX PLUS® Wrench
RH274...	030.350P.0852	T15PQ



Indexable insert

S274...SF

Depth of cut up to .098"

precision ground

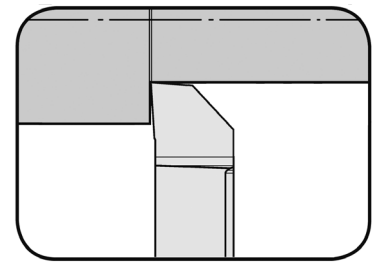

for Toolholder

Type H274...SF

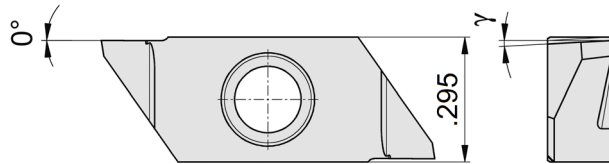

Location

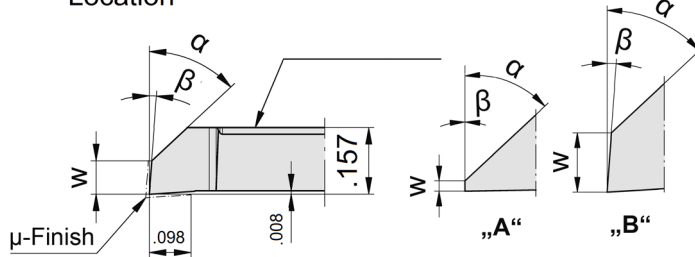

R = right hand version shown

L = left hand version

Indexability length ± .0006"

Part number	w	γ	α	Form	β	Size	Carbide grades					
							MG12	AC25	AC2P	ES15	ES1P	
RS274.0547.04.SF	.002	0°	47°	A	0°	04	○	●	●	●	●	
R/LS274.2047.03.SF	.079	3°	47°	B	4°	04	△/△	△/△	△/△	▲/△	△/△	
▲ on stock Δ 4 weeks x upon request ● recommended ○ alternative recommendation - not suitable							P	○	●	●	●	●
							M	-	○	○	○	○
							K	-	-	-	●	-
							N	-	-	-	-	-
							S	-	-	-	-	-
							H	-	-	-	-	-

Legend:
 □ uncoated grades
 ■ coated grades
 ■ brazed/Cermet

Dimensions in inch

State R or L version



Indexable insert

S274...SF

Depth of cut up to .098"

precision ground

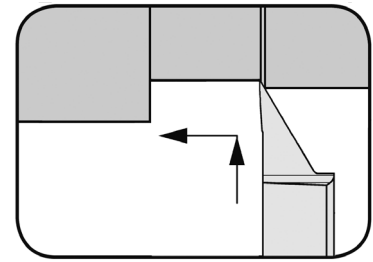

for Toolholder

Type H274...SF

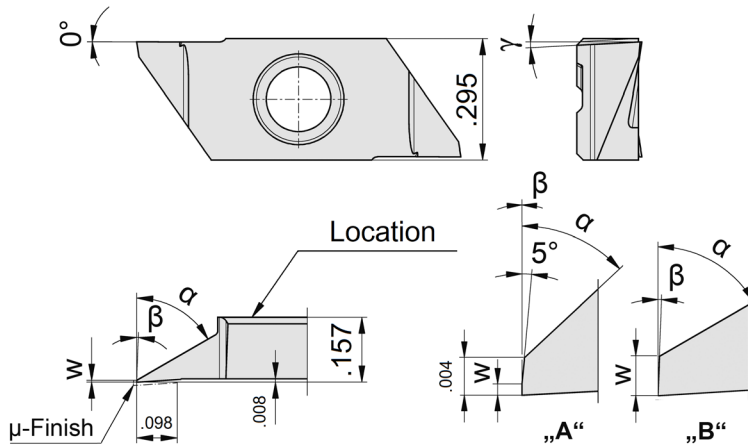

R = right hand version shown

L = left hand version

Indexability length ± .0006"

Part number	w	γ	α	Form	β	Size	Carbide grades				
							MG12	AC25	AC2P	ES15	ES1P
RS274.0147.04.SF	.001	0°	47°	A	0°	04	o	•	•	•	•
R/LS274.0160.03.SF	.004	3°	60°	B	2°	04	Δ/Δ	Δ/Δ	Δ/Δ	Δ/Δ	Δ/Δ
▲ on stock Δ 4 weeks x upon request							P	o	•	•	•
● recommended							M	-	o	o	o
o alternative recommendation							K	-	-	-	•
- not suitable							N	-	-	-	-
■ uncoated grades							S	-	-	-	-
■ coated grades							H	-	-	-	-
■ brazed/Cermet											

Dimensions in inch

State R or L version



Indexable insert

S274...SF

Depth of cut up to .157"

precision ground

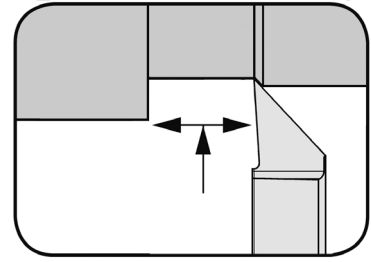

for Toolholder

Type H274...SF

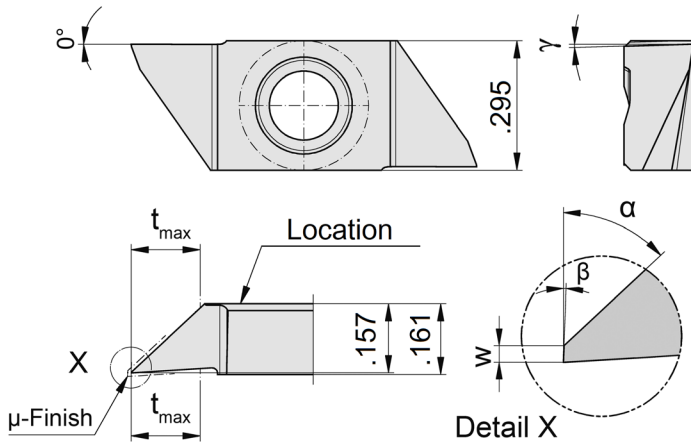

R = right hand version shown

Indexability length ± .0006"

Part number	w	t _{max}	γ	α	β	Size	AC25	AC2P	ES15	ES1P
RS274.0247.04.SF	.001	.157	1.5°	47°	2°	04	Δ	Δ	▲	Δ
							P	•	•	•
							M	○	○	○
							K	-	-	-
							N	-	-	-
							S	-	-	-
							H	-	-	-

▲ on stock Δ 4 weeks x upon request
 • recommended
 ○ alternative recommendation
 - not suitable

□ uncoated grades
 ■ coated grades
 ■ brazed/Cermet

Dimensions in inch

Carbide grades



Indexable insert

S274...SF

Depth of groove up to $.236''$
 Width of groove $.031 - .059''$

precision ground

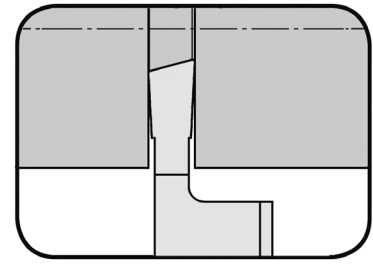

for Toolholder

Type H274...SF

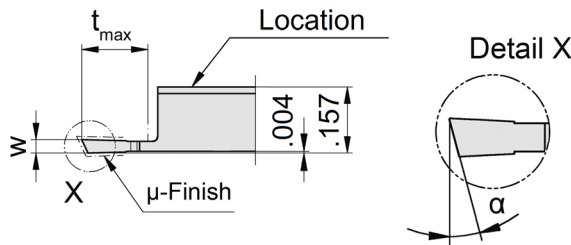
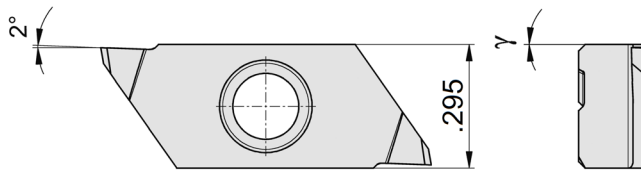

R = right hand version shown

L = left hand version

Indexability length $\pm .0006''$

Part number	w	t _{max}	α	γ	Size	Carbide grades				
						MG12	AC25	AC2P	ES15	ES1P
R/LS274.2508.04.SF	.031	.157	25°	0°	04	ΔΔ	ΔΔ	ΔΔ	ΔΔ	ΔΔ
RS274.2509.04.SF	.035	.157	25°	0°	04		Δ	Δ	Δ	Δ
RS274.2510.04.SF	.039	.157	25°	0°	04		Δ	Δ	▲	Δ
RS274.2510.06.SF	.039	.236	25°	0°	04		Δ	Δ	Δ	Δ
RS274.2512.06.SF	.047	.236	25°	0°	04		Δ	Δ	Δ	Δ

▲ on stock Δ 4 weeks x upon request

- recommended
- alternative recommendation
- not suitable

- uncoated grades
- coated grades
- brazed/Cermet

Dimensions in inch

State R or L version

t_{max} .236'' can be reached only with workpiece $\varnothing \leq .984''$.

	P	M	K	N	S	H
P	○	●	●	●	●	●
M	-	○	○	○	○	○
K	-	-	-	●	-	-
N	-	-	-	-	-	-
S	-	-	-	-	-	-
H	-	-	-	-	-	-

Carbide grades



Indexable insert

S274...SF

Depth of groove up to $.236''$
 Width of groove $.031 - .059''$

precision ground

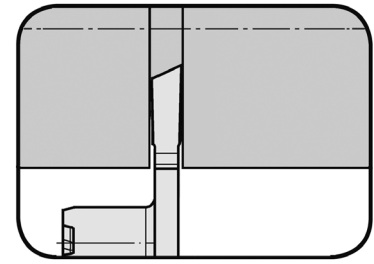

for Toolholder

Type H274...SF

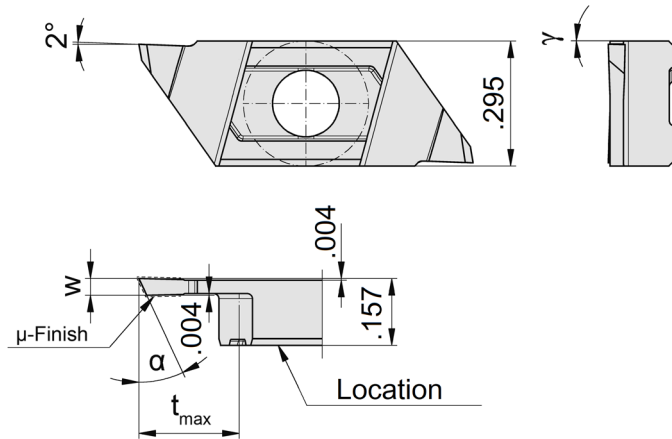

Indexability length $\pm .0006''$

L = left hand version shown

Part number	w	t_{max}	α	γ	Size	Carbide grades			
						AC25	AC2P	ES15	ES1P
LS274.2508.04.SF.R	.031	.157	25°	0°	04	▲	▲	▲	▲
LS274.2509.04.SF.R	.035	.157	25°	0°	04	▲	▲	▲	▲
LS274.2510.06.SF.R	.039	.236	25°	0°	04	▲	▲	▲	▲
LS274.2512.06.SF.R	.047	.236	25°	0°	04	▲	▲	▲	▲
LS274.2515.06.SF.R	.059	.236	25°	0°	04	▲	▲	▲	▲
						P	●	●	●
						M	○	○	○
						K	-	-	-
						N	-	-	-
						S	-	-	-
						H	-	-	-

▲ on stock Δ 4 weeks x upon request

● recommended

○ alternative recommendation

- not suitable

□ uncoated grades

■ coated grades

■ brazed/Cermet

Dimensions in inch

Carbide grades

t_{max} $.236''$ can be reached only with workpiece $\varnothing \leq .984''$.



Indexable insert

S274...SF

Depth of groove up to $.236''$
 Width of groove $.031 - .071''$

precision ground

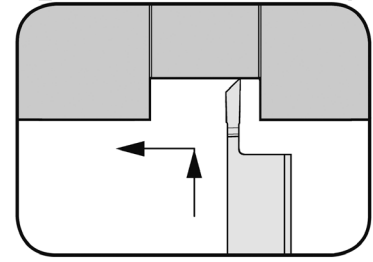

for Toolholder

Type H274...SF

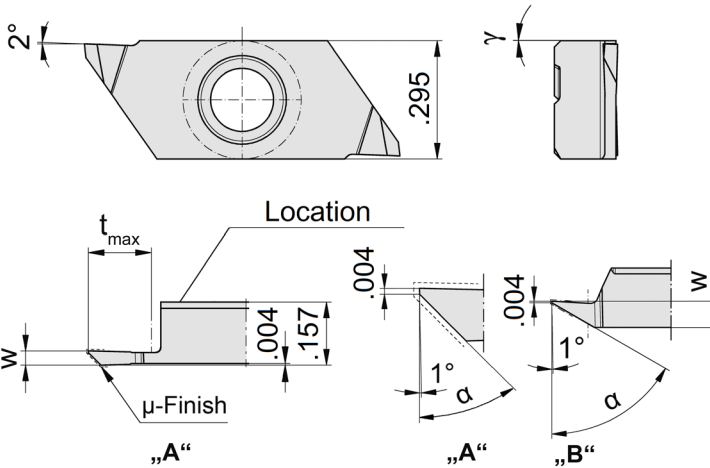

R = right hand version shown

L = left hand version

Indexability length $\pm .0006''$

Part number	w	t _{max}	α	γ	Form	Size	Carbide grades				
							MG12	AC25	AC2P	ES15	ES1P
RS274.4508.04.SF	.031	.157	45°	0°	A	04		Δ	Δ	Δ	Δ
R/LS274.4509.04.SF	.035	.157	45°	0°	A	04	Δ/Δ	Δ/Δ	Δ/Δ	▲/Δ	Δ/Δ
RS274.4510.06.SF	.039	.236	45°	0°	A	04		Δ	Δ	▲	▲
RS274.4512.06.SF	.047	.236	45°	0°	A	04		Δ	Δ	Δ	▲
RS274.6015.02.SF	.071	.098	60°	0°	B	04		Δ	Δ	▲	▲
RS274.7010.02.SF	.047	.098	70°	0°	B	04		Δ	Δ	Δ	▲

▲ on stock Δ 4 weeks x upon request

- recommended
- alternative recommendation
- not suitable

- uncoated grades
- coated grades
- brazed/Cermet

Dimensions in inch

State R or L version

t_{max} .236'' can be reached only with workpiece $\varnothing \leq .984''$.

P	○	●	●	●	●
M	-	○	○	○	○
K	-	-	-	●	-
N	-	-	-	-	-
S	-	-	-	-	-
H	-	-	-	-	-

Carbide grades



Indexable insert

S274...SF

Depth of groove up to .118"
Width of groove .020 - .079"

precision ground

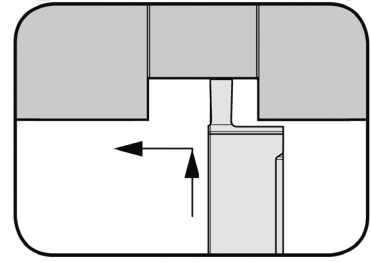

for Toolholder

Type H274...SF

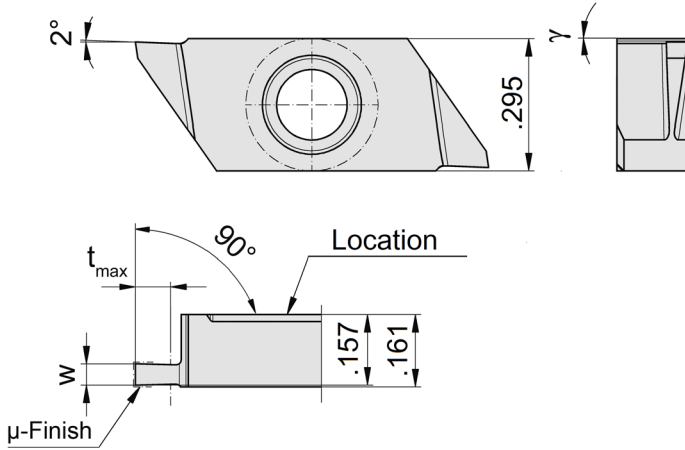

R = right hand version shown

Indexability length ± .0006"

Part number	w	t _{max}	γ	Size	AC25	AC2P	ES15	ES1P
					AC25	AC2P	ES15	ES1P
RS274.0005.01.SF	.020	.039	0°	04	Δ	Δ	▲	Δ
RS274.0010.02.SF	.039	.079	0°	04	Δ	Δ	▲	Δ
RS274.0012.02.SF	.047	.079	0°	04	Δ	Δ	Δ	Δ
RS274.0015.03.SF	.059	.118	0°	04	Δ	Δ	Δ	Δ
RS274.0020.03.SF	.079	.118	0°	04	Δ	Δ	Δ	Δ

▲ on stock Δ 4 weeks x upon request

● recommended

○ alternative recommendation

- not suitable

□ uncoated grades

■ coated grades

■ brazed/Cermet

Dimensions in inch

	P	M	K	N	S	H
AC25	●	○	-	-	-	-
AC2P	●	○	-	-	-	-
ES15	●	○	●	-	-	-
ES1P	●	○	-	-	-	-

Carbide grades

32T

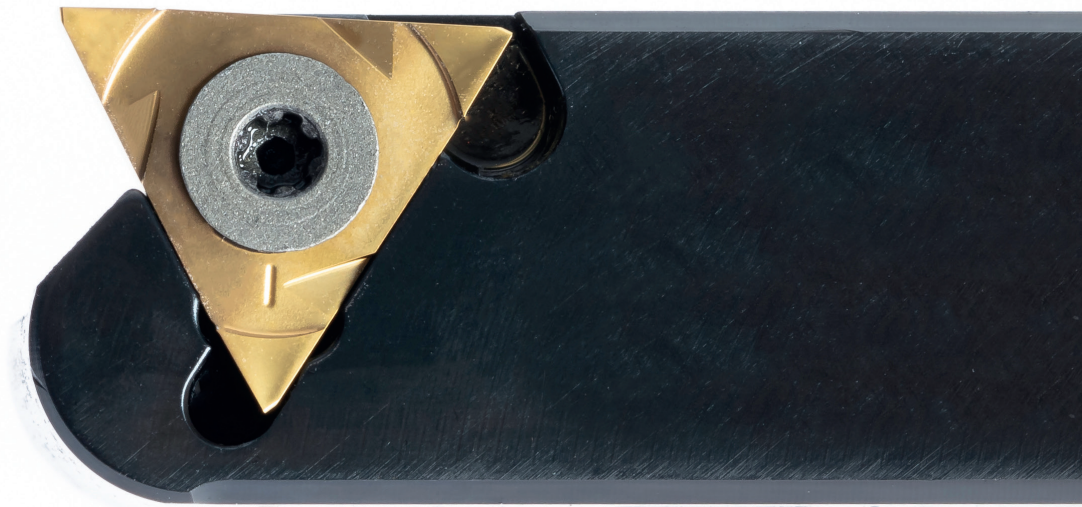

Toolholder with Inserts

Width of groove .02 - .098"

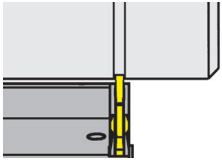

w = .02 - .098
(0.5 - 2.5 mm)
t_{max} = .138 (3.50 mm)

Toolholder
H32T

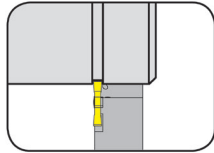

Page
M3-M4

Indexable Insert
S32T

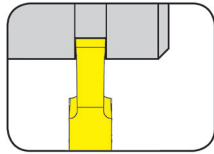

Page
M5-M6

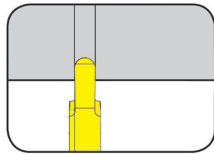

Page
M7

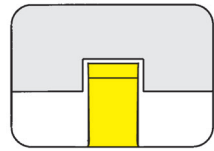

Page
M8

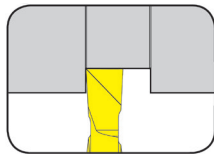

Page
M9

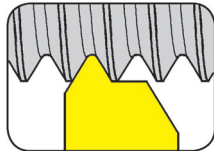

Page
M10

Grooving and Parting off (external)



Toolholder

HU32T

with through coolant supply

Depth of groove up to

.138"

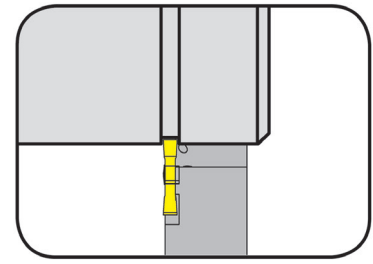

for Indexable insert

Type S32T

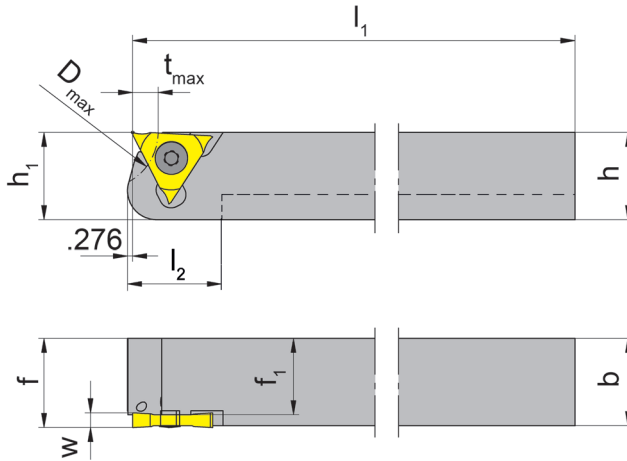

R = right hand version shown

L = left hand version

Part number	h	b	l_1	l_2	h_1	f_1	f	D_{max}	t_{max}	Size
R/LHU32T.0375.6.10.IK	.375	.375	3.996	.512	.375	.385	f_1+s_1	.610	.138	01
R/LHU32T.0375.6.20.IK	.375	.375	3.996	.512	.375	.385	f_1+s_1	.610	.138	02
R/LHU32T.0500.6.10.IK	.500	.500	3.996	-	.500	.510	f_1+s_1	.610	.138	01
R/LHU32T.0500.6.20.IK	.500	.500	3.996	-	.500	.510	f_1+s_1	.610	.138	02
R/LHU32T.0625.6.10.IK	.625	.625	5.118	-	.625	.635	f_1+s_1	.610	.138	01
R/LHU32T.0625.6.20.IK	.625	.625	5.118	-	.625	.635	f_1+s_1	.610	.138	02

State R or L version

w, s_1 see indexable inserts

Dimensions in inch

For torque specification of the screw, please see Technical Instructions.

Spare Parts

Toolholder	Threaded Pin	Coolant supply	Clamping Screw	TORX PLUS® Wrench	Screw Plug
R/LHU32T...	3.03.913	004.00.22	030.2507.T7P	T7PL	
R/LHU32T.0625.6...	18.05.913	004.00.16	030.2507.T7P	T7PL	18.908

Grooving and Parting off (external)



Toolholder

H32T

with through coolant supply

Depth of groove

3.5 mm

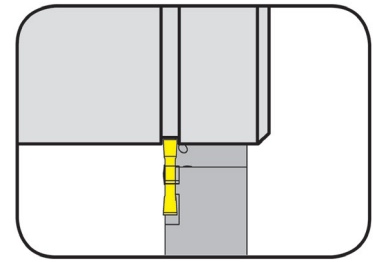

for Indexable insert

Type S32T

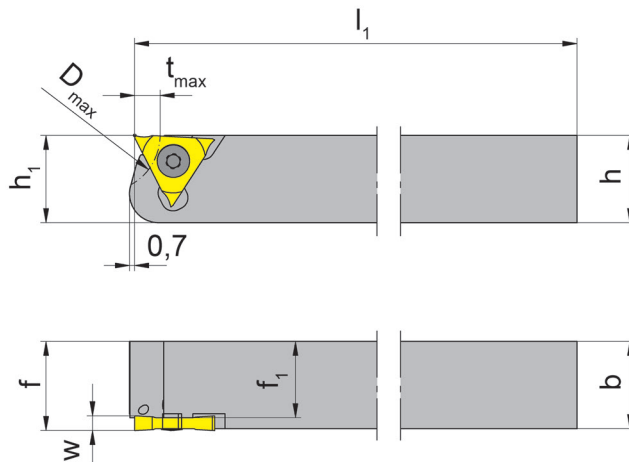

R = right hand version shown

L = left hand version

Part number	h	b	l ₁	l ₂	h ₁	f ₁	f	D _{max}	t _{max}	Size
R/LH32T.0808.6.10.IK	8	8	100	13	8	6.5	f ₁ +s ₁	15.5	3.5	01
R/LH32T.0808.6.20.IK	8	8	100	13	8	6.0	f ₁ +s ₁	15.5	3.5	02
R/LH32T.1010.6.10.IK	10	10	100	-	10	8.5	f ₁ +s ₁	15.5	3.5	01
R/LH32T.1010.6.20.IK	10	10	100	-	10	8.0	f ₁ +s ₁	15.5	3.5	02
R/LH32T.1212.6.10.IK	12	12	100	-	12	10.5	f ₁ +s ₁	15.5	3.5	01
R/LH32T.1212.6.20.IK	12	12	100	-	12	10.0	f ₁ +s ₁	15.5	3.5	02
R/LH32T.1616.6.10.IK	16	16	125	-	16	14.5	f ₁ +s ₁	15.5	3.5	01
R/LH32T.1616.6.20.IK	16	16	125	-	16	14.0	f ₁ +s ₁	15.5	3.5	02

State R or L version

w, s₁ see indexable inserts

Dimensions in mm

Torque specification of the screw 030.2507.T7P = 1,5 Nm.

Spare Parts

Toolholder	Threaded Pin	Clamping Screw	TORX PLUS® Wrench	Coolant supply	Screw Plug
R/LH32T.0808.6...	3.03.913	030.2507.T7P	T7PL	004.00.37	
R/LH32T.1010.6...	3.03.913	030.2507.T7P	T7PL	004.00.22	
R/LH32T.1212.6...	3.03.913	030.2507.T7P	T7PL	004.00.22	
R/LH32T.1616.6...	18.05.913	030.2507.T7P	T7PL	004.00.16	18.908

M4

Call Us Toll Free (888) 818-4676

Grooving and Parting off (external)



Indexable insert

S32T

Depth of groove up to	.138"
Width of groove	.020 - .098"

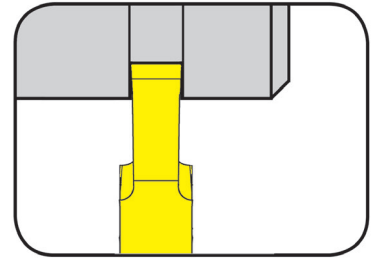

for Toolholder

Type H32T
HU32T

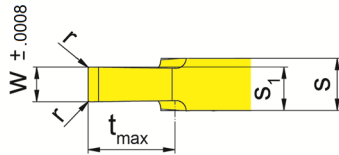
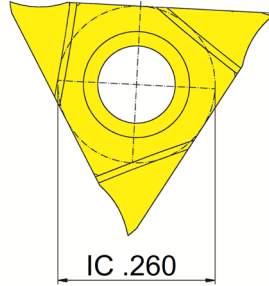

Part number	w	r	s	s ₁	t _{max}	Size	EG35	EG55
S32T.0050.00	.020	.002	.059	.039	.059	01	▲	
S32T.0070.00	.028	.002	.059	.043	.079	01	▲	
S32T.0080.00	.031	.002	.059	.045	.098	01	▲	
S32T.0100.00	.039	.002	.059	.049	.098	01		▲
S32T.0120.00	.047	.002	.059	.053	.098	01		▲
S32T.0150.00	.059	.002	.059	.059	.098	01		▲
S32T.0200.00	.079	.002	.059	.069	.138	01		▲
S32T.0250.00	.098	.002	.079	.089	.138	02		▲

- ▲ on stock Δ 4 weeks x upon request
- recommended
- alternative recommendation
- not suitable
- uncoated grades
- coated grades
- brazed/Cermet

Dimensions in inch

	EG35	EG55
P	●	●
M	●	○
K	○	○
N	-	-
S	-	-
H	-	-

Carbide grades

Indexable inserts can be used in right and left hand toolholders.

Grooving and Parting off (external)



Indexable insert

S32T

Depth of groove up to	.138"
Width of groove	.079"

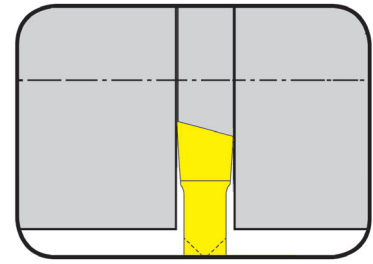

for Toolholder

Type H32T
HU32T

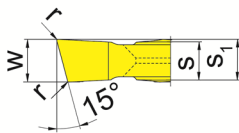
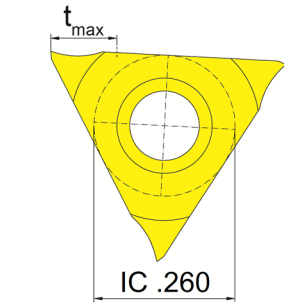

R = right hand version shown

L = left hand version

Part number	w	r	s	s ₁	t _{max}	Size	EG55
R/LS32T.1520.10	.079	.002	.059	.069	.138	01	▲/▲
							P ●
							M ○
							K ○
							N -
							S -
							H -

- ▲ on stock Δ 4 weeks x upon request
- recommended
- alternative recommendation
- not suitable

- uncoated grades
- coated grades
- brazed/Cermet

Dimensions in inch

Carbide grades

State R or L version

Use right hand inserts in right hand toolholders and left hand inserts in left hand toolholders

Indexable insert

S32T

Width of groove	.020 - .079"
Full radius	.010 - .039"

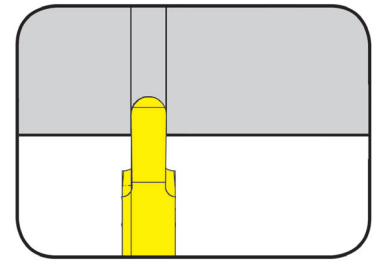

for Toolholder

Type H32T
HU32T

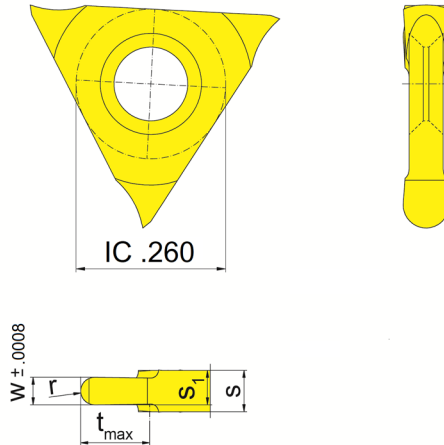

Part number	w	s	s ₁	t _{max}	r	Size	Carbide grades	
							EG35	EG55
S32T.0050.25	.020	.059	.039	.059	.010	01	▲	●
S32T.0100.50	.039	.059	.049	.098	.020	01		▲
S32T.0200.10	.079	.059	.069	.138	.039	01		▲
							P	●
							M	●
							K	○
							N	-
							S	-
							H	-

▲ on stock Δ 4 weeks x upon request

- recommended
- alternative recommendation
- not suitable

- uncoated grades
- coated grades
- brazed/Cermet

Dimensions in inch

Carbide grades

Indexable inserts can be used in right and left hand toolholders.

Indexable insert

S32T

Circlip grooves
Width of circlip Nw

DIN471/472
.013 - .085"

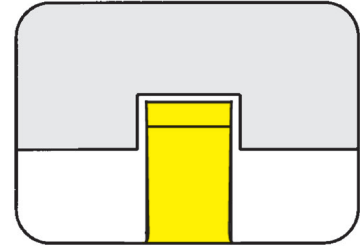

for Toolholder

Type H32T
HU32T

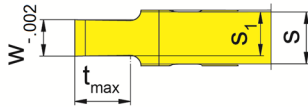
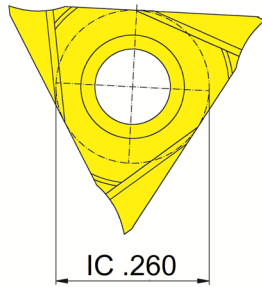

Part number	w	Nw	s	s ₁	t _{max}	Size	EG35	EG55
S32T.0034.01.00	.016	.013	.059	.037	.024	01	▲	
S32T.0044.01.00	.020	.017	.059	.039	.028	01	▲	
S32T.0050.01.00	.022	.020	.059	.040	.028	01	▲	
S32T.0060.01.00	.026	.024	.059	.042	.031	01	▲	
S32T.0070.01.00	.030	.028	.059	.044	.043	01	▲	
S32T.0080.01.00	.034	.031	.059	.046	.047	01	▲	
S32T.0090.01.00	.038	.035	.059	.048	.055	01	▲	
S32T.0100.01.00	.042	.039	.059	.050	.063	01		▲
S32T.0110.01.00	.049	.043	.059	.054	.063	01		▲
S32T.0130.01.00	.057	.051	.059	.057	.079	01		▲
S32T.0160.01.00	.069	.063	.059	.063	.118	01		▲
S32T.0185.01.00	.078	.073	.059	.068	.118	01		▲
S32T.0215.01.00	.090	.085	.079	.084	.118	02		▲

▲ on stock Δ 4 weeks x upon request
● recommended
○ alternative recommendation
- not suitable

■ uncoated grades
■ coated grades
■ brazed/Cermet

Dimensions in inch

	P	M	K	N	S	H
EG35	●	●	○	-	-	-
EG55	●	○	○	-	-	-

Carbide grades

Indexable inserts can be used in right and left hand toolholders.

Indexable insert

S32T

Metric ISO-thread

Depth of groove up to
Width of groove

.079"
.059 - .098"

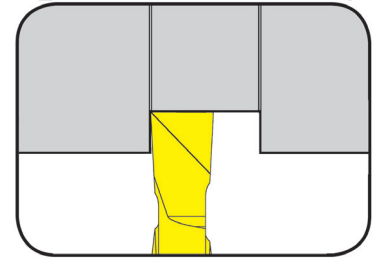

for Toolholder

Type H32T
HU32T

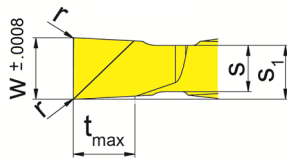
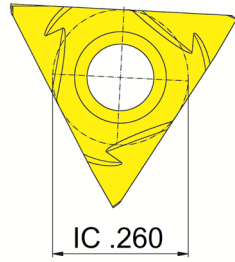

R = right hand version shown

L = left hand version

Part number	w	r	s	s ₁	t _{max}	Size	EG55
R/LS32T.0150.P0	.059	.002	.059	.067	.079	01	▲▲
R/LS32T.0200.P0	.079	.002	.059	.069	.079	01	▲▲
R/LS32T.0250.P0	.098	.004	.079	.089	.079	02	▲▲

▲	on stock	Δ 4 weeks	x upon request
●	recommended		
○	alternative recommendation		
-	not suitable		
□	uncoated grades		
■	coated grades		
■	brazed/Cermet		

P	•
M	○
K	○
N	-
S	-
H	-

Dimensions in inch

Carbide grades

State R or L version

Threading (external) Full profile



Indexable insert

S32T

Pitch	0.50 - 1.50 mm
-------	----------------

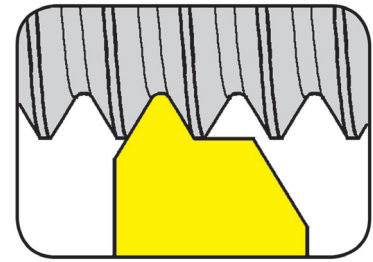

for Toolholder

Type H32T
HU32T

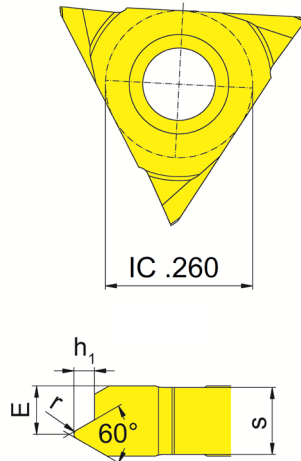

R = right hand version shown

L = left hand version

Part number	P mm	E	r	h ₁	s	Size	EG55
R/LS32T.0305.02	0.50	.063	.003	.013	.079	02	▲▲
R/LS32T.0306.02	0.60	.059	.004	.015	.079	02	▲▲
R/LS32T.0307.02	0.70	.059	.004	.017	.079	02	▲▲
R/LS32T.0407.02	0.75	.059	.004	.019	.079	02	▲▲
R/LS32T.0408.02	0.80	.055	.005	.020	.079	02	▲▲
R/LS32T.0610.02	1.00	.055	.006	.024	.079	02	▲▲
R/LS32T.0712.02	1.25	.055	.007	.031	.079	02	▲▲
R/LS32T.0915.02	1.50	.051	.009	.037	.079	02	▲▲

▲ on stock Δ 4 weeks x upon request

● recommended

○ alternative recommendation

- not suitable

■ uncoated grades

■ coated grades

■ brazed/Cermet

Dimensions in inch

State R or L version

P	●
M	○
K	○
N	-
S	-
H	-

Carbide grades

34T



Toolholder with Inserts

Width of groove .041 - .197"

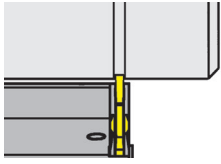

w = .041 - .197"
 (1.03 - 5.0 mm)
 t_{max} = .256 (6.50 mm)

Toolholder
 H34T

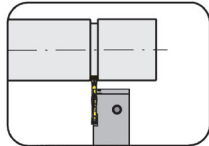

Page
 N3-N5

Indexable Insert
 S34T

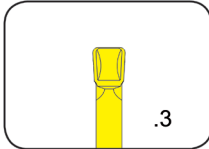

Page
 N6

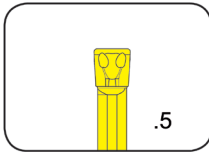

Page
 N7

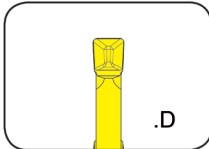

Page
 N8

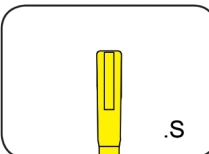

Page
 N9

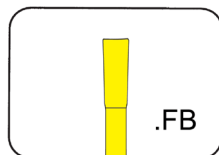

Page
 N10

Toolholder

H34T

Depth of groove up to
Clamping range

6.5 mm
2 - 4.01 mm

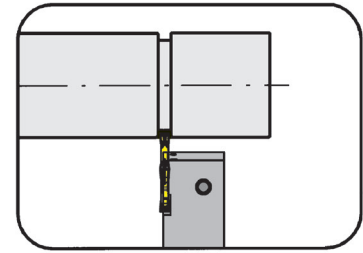

for Indexable insert

Type S34T...3S

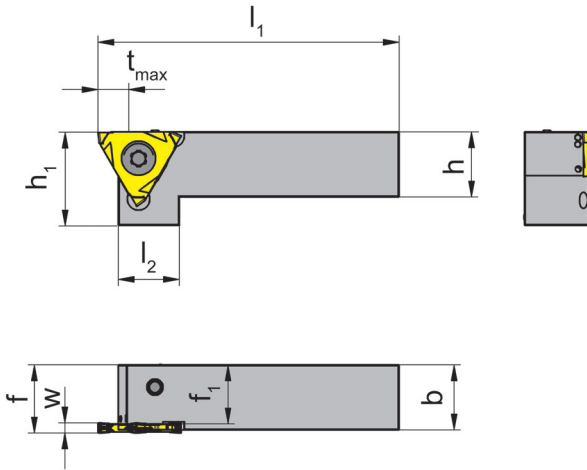

R = right hand version shown

L = left hand version

with through coolant supply

Part number	h	b	l ₁	l ₂	h ₁	f ₁	f	t _{max}	Size	Clamping range
R/LH34T.1616.6.00.IK	16	16	74	16.2	16	15.1	f ₁ +w - a ₁	6.5	01	1.03 - 1.03
R/LH34T.2020.4.00.IK	20	20	89	-	20	19.1	f ₁ +w - a ₁	6.5	01	1.03 - 1.03

State R or L version

w see indexable inserts

Dimensions in mm

For torque specification of the screw, please see Technical Instructions.

Spare Parts

Toolholder	Sealing plug	Threaded Pin	Coolant supply	Clamping Screw	TORX PLUS® Wrench	O - ring
R/LH34T.1616.6.00.IK	004.00.26	18.05.913	004.00.16	030.4093.T15P	T15PQ	
R/LH34T.2020.4.00.IK				030.4093.T15P	T15PQ	12.37.2.62.3601

Toolholder

H34T

Depth of groove up to
Clamping range

6.5 mm
2 - 4.01 mm

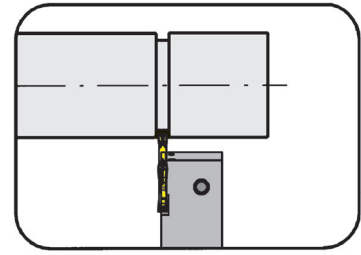

for Indexable insert

Type S34T

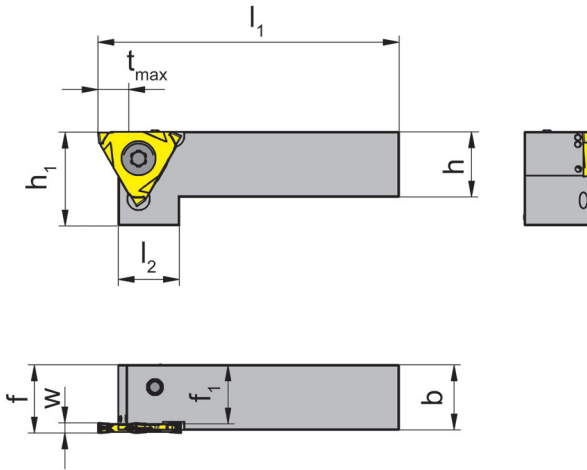

R = right hand version shown

L = left hand version

with through coolant supply

Part number	h	b	l_1	l_2	h_1	f_1	f	t_{max}	Size	Clamping range
R/LH34T.1212.6.10.IK	12	12	74	16.2	21	10.50	$f_1 + w - a_1$	6.5	01	2.00 - 2.00
R/LH34T.1212.6.20.IK	12	12	74	16.2	21	11.76	$f_1 + w - a_1$	6.5	02	2.00 - 2.00
R/LH34T.1212.6.30.IK	12	12	74	20.0	21	12.26	$f_1 + w - a_1$	6.5	03	3.01 - 4.00

State R or L version

w see indexable inserts

Dimensions in mm

For torque specification of the screw, please see Technical Instructions.

Spare Parts

Toolholder	Coolant supply	Clamping Screw	TORX PLUS® Wrench
R/LH34T.1212.6.10.IK	004.00.61	030.4093.T15P	T15PQ
R/LH34T.1212.6.20.IK	004.00.61	030.4010.T15P	T15PQ
R/LH34T.1212.6.30.IK	004.00.61	030.5012.T15P	T15PQ

Toolholder

H34T

Depth of groove up to 6.5 mm
Clamping range 2 - 5 mm

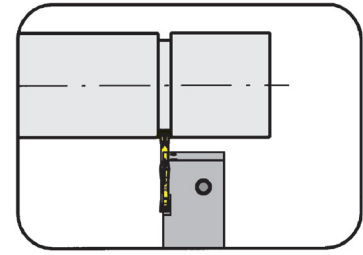

for Indexable insert

Type S34T

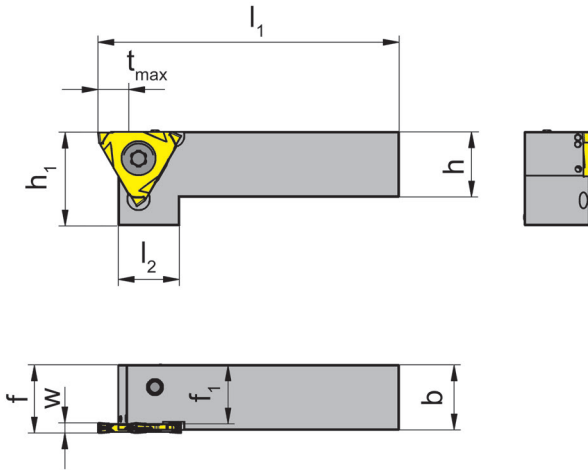

R = right hand version shown

L = left hand version

with through coolant supply

Part number	h	b	l ₁	l ₂	h ₁	f ₁	f	t _{max}	Size	Clamping range
R/LH34T.1616.4.10.IK	16	16	69	15	21	14.5	f ₁ +w - a ₁	6.5	01	2.00 - 2.00
R/LH34T.2020.4.10.IK	20	20	84	15	25	18.5	f ₁ +w - a ₁	6.5	01	2.00 - 2.00
R/LH34T.2525.4.10.IK	25	25	99	15	30	23.5	f ₁ +w - a ₁	6.5	01	2.00 - 2.00
R/LH34T.1616.4.20.IK	16	16	69	15	21	13.5	f ₁ +w - a ₁	6.5	02	2.01 - 3.00
R/LH34T.2020.4.20.IK	20	20	84	15	25	17.5	f ₁ +w - a ₁	6.5	02	2.01 - 3.00
R/LH34T.2525.4.20.IK	25	25	99	15	30	22.5	f ₁ +w - a ₁	6.5	02	2.01 - 3.00
R/LH34T.2020.4.30.IK	20	20	84	15	25	16.5	f ₁ +w - a ₁	6.5	03	3.01 - 4.00
R/LH34T.2525.4.30.IK	25	25	99	15	30	21.5	f ₁ +w - a ₁	6.5	03	3.01 - 4.00
R/LH34T.2020.4.40.IK	20	20	84	15	25	15.5	f ₁ +w - a ₁	6.5	04	4.01 - 5.00
R/LH34T.2525.4.40.IK	25	25	99	15	30	20.5	f ₁ +w - a ₁	6.5	04	4.01 - 5.00

State R or L version

w see indexable inserts

Dimensions in mm

For torque specification of the screw, please see Technical Instructions.

Spare Parts

Toolholder	O - ring	Clamping Screw	TORX PLUS® Wrench
R/LH34T...4.10.IK	12.37.2.62.3601	030.4093.T15P	T15PQ
R/LH34T...4.20.IK	12.37.2.62.3601	030.4010.T15P	T15PQ
R/LH34T...4.30.IK	12.37.2.62.3601	030.5012.T15P	T15PQ
R/LH34T...4.40.IK	12.37.2.62.3601	030.5012.T15P	T15PQ

Indexable insert

S34T

with sintered geometries

Width of groove	.079 - .197"
-----------------	--------------

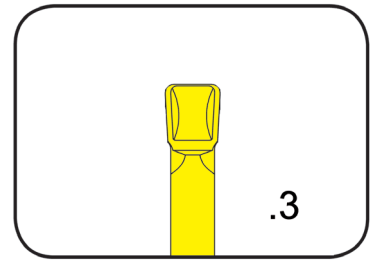

for Toolholder

Type H34T

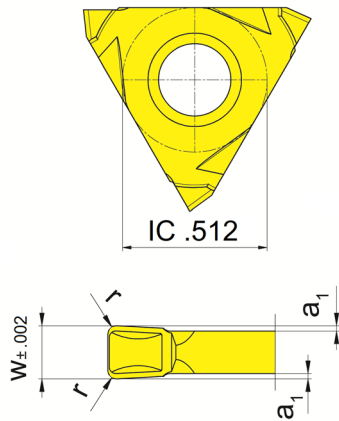

Geometry .3

Part number	w	r	a ₁	Size	Carbide grades	
					AS45	EG55
S34T.0200.32	.079	.008	.01	01	▲	▲
S34T.0200.34	.079	.016	.01	01	▲	▲
S34T.0250.32	.098	.008	.01	02	△	▲
S34T.0250.34	.098	.016	.01	02	△	▲
S34T.0300.32	.118	.008	.01	02	▲	▲
S34T.0300.34	.118	.016	.01	02	△	▲
S34T.0400.32	.157	.008	.01	03	▲	▲
S34T.0500.32	.197	.008	.01	04	▲	▲
S34T.0500.34	.197	.016	.01	04	△	▲

▲ on stock △ 4 weeks x upon request

- recommended
- alternative recommendation
- not suitable

- uncoated grades
- coated grades
- brazed/Cermet

Dimensions in inch

	AS45	EG55
P	●	●
M	●	○
K	●	○
N	○	-
S	●	-
H	-	-

Carbide grades

Indexable inserts can be used in right and left hand toolholders.

Indexable insert

S34T

with sintered geometries

Width of groove .098 - .197"

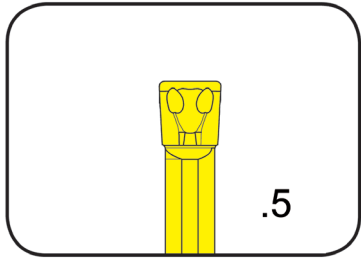

for Toolholder

Type H34T

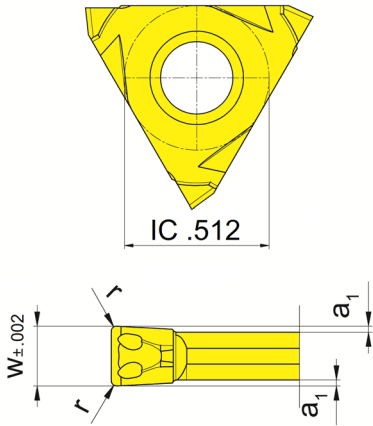

Geometry .5

Part number	w	r	a ₁	Size	Carbide grades	
					AS45	EG55
S34T.0250.52	.098	.008	.01	02	▲	▲
S34T.0250.54	.098	.016	.01	02	▲	▲
S34T.0300.52	.118	.008	.01	02	△	▲
S34T.0300.54	.118	.016	.01	02	△	▲
S34T.0400.52	.157	.008	.01	03	▲	▲
S34T.0400.54	.157	.016	.01	03	▲	▲
S34T.0500.52	.197	.008	.01	04	▲	▲
S34T.0500.54	.197	.016	.01	04	△	▲

▲ on stock Δ 4 weeks x upon request
 ● recommended
 ○ alternative recommendation
 - not suitable
 □ uncoated grades
 ■ coated grades
 ■ brazed/Cermet
 Dimensions in inch

	AS45	EG55
P	●	●
M	●	○
K	●	○
N	○	-
S	●	-
H	-	-

Carbide grades

Indexable inserts can be used in right and left hand toolholders.

Indexable insert

S34T

with sintered geometries

Width of groove	.079 - .118"
-----------------	--------------

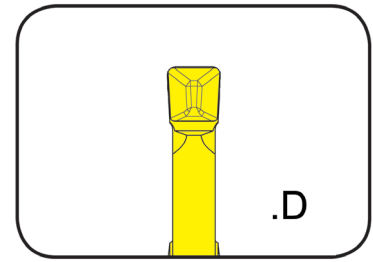

for Toolholder

Type H34T

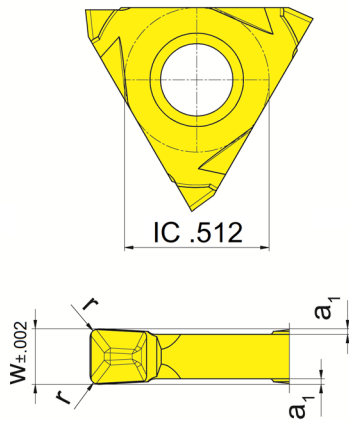

Geometry .D

Part number	w	r	a ₁	Size	Carbide grades	
					AS45	EG55
S34T.0200.D2	.079	.008	.01	01	▲	▲
S34T.0200.D4	.079	.016	.01	01	△	▲
S34T.0250.D2	.098	.008	.01	02	△	▲
S34T.0250.D4	.098	.016	.01	02	▲	▲
S34T.0300.D2	.118	.008	.01	02	△	▲
S34T.0300.D4	.118	.016	.01	02	△	▲

▲ on stock Δ 4 weeks x upon request

- recommended
- alternative recommendation
- not suitable

- uncoated grades
- coated grades
- brazed/Cermet

Dimensions in inch

	AS45	EG55
P	●	●
M	●	○
K	●	○
N	○	-
S	●	-
H	-	-

Carbide grades

Indexable inserts can be used in right and left hand toolholders.

Indexable insert

S34T

Width of groove	.041"
-----------------	-------

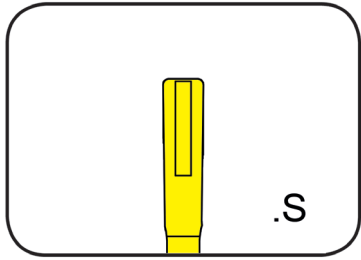

for Toolholder

Type H34T...00.IK

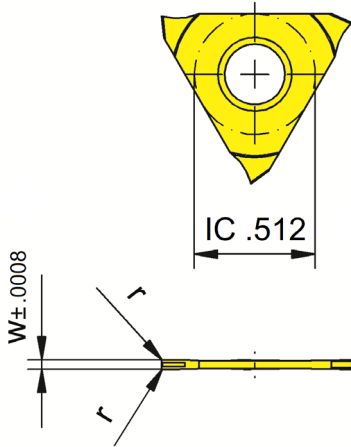

R = right hand version shown

L = left hand version

Geometry .S

Part number	w	r	Size	IG35
R/LS34T.0100.3S	.041	.006	01	▲/▲
				P -
				M •
				K -
				N -
				S •
				H -

- ▲ on stock Δ 4 weeks x upon request
- recommended
- o alternative recommendation
- not suitable

- uncoated grades
- coated grades
- brazed/Cermet

Dimensions in inch

Carbide grades

State R or L version

Indexable inserts can be used in right and left hand toolholders.

Indexable insert

S34T

Width of groove .039-.059"

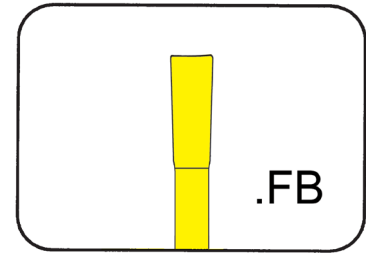

for Toolholder

Type H34T...00.IK

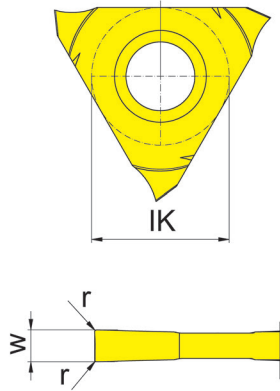

R = right hand version shown

L = left hand version

Geometry .FB

Part number	w	r	Size	EG35
R/LS34T.FB10.01	.039	.004	01	▲
R/LS34T.FB15.01	.059	.004	01	▲

▲ on stock Δ 4 weeks x upon request

- recommended
- alternative recommendation
- not suitable

- uncoated grades
- coated grades
- brazed/Cermet

Dimensions in inch

P	-
M	•
K	-
N	-
S	•
H	-

Carbide grades

State R or L version

Use right hand inserts in right hand toolholders and left hand inserts in left hand toolholders..

312



Toolholder with Inserts

Width of groove .020 - .248"

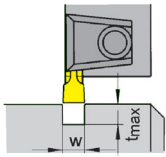

$w = .02 - .248"$
(0.5 - 6.3 mm)
 $t_{max} = .315$ (8.0 mm)



$w = .02 - .248"$
(0.5 - 6.3 mm)
 $t_{max} = .217"$ (5.5 mm)
 $D \geq 1.811"$ (46 mm)

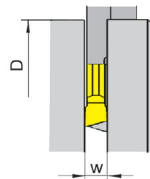

$w = .02 - .248"$
0.5 - 6.3 mm
 $D = .472"$ (12 mm)
 $t_{max} = .315"$ (8 mm)

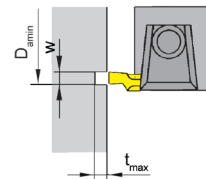

$w = .059 - .118"$
(1.5 - 3 mm)
 $t_{max} = .118"$ (3 mm)
 $D_{amin} = .787"$ (20 mm)

Toolholder
360/361/368/369

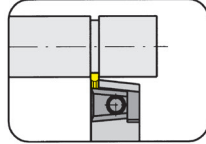

Page
O3-O10, O20-O22

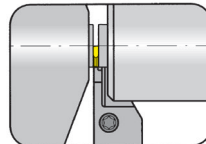

Page
O11-O13

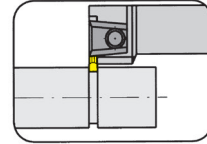

Page
O14-O15

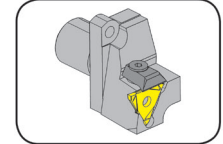

Page
O16

Toolholder
64/65/99
N67/N68/N98/390/391
309/340

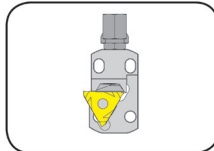

Page
O17-O18

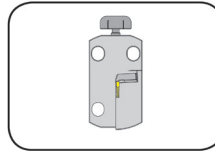

Page
O19

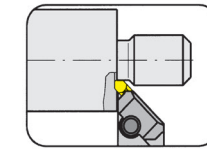

Page
O23-O24

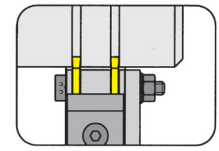

Page
O25-O26

Toolholder
340/330

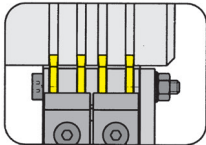

Page
O27-O28

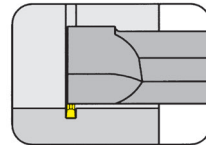

Page
O29-O30

Indexable Insert
S312



Page
O31

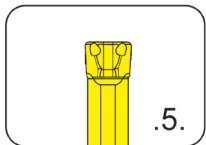

Page
O32-O33

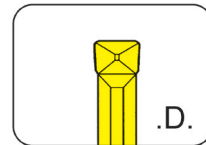

Page
O34-O35

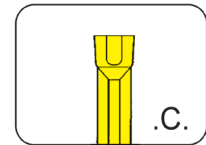

Page
O36

Indexable Insert
312

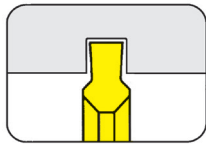

Page
O37

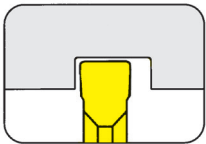

Page
O38-O46

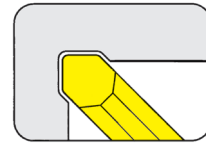

Page
O47-O48

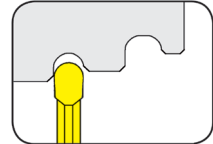

Page
O49-O50

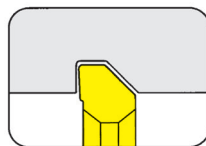

Page
O51-O52

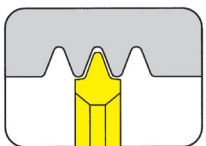

Page
O53

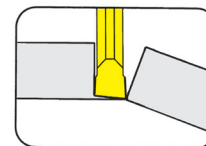

Page
O55-O57

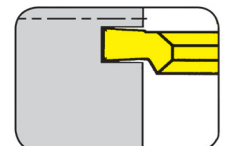

Page
O58-O59

Toolholder

U360

Depth of groove up to $.236''$
Clamping range $.020 - .114''$

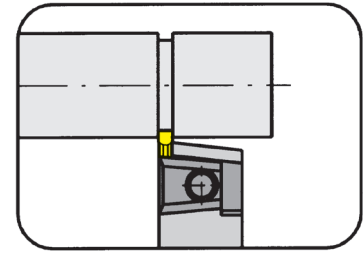

for Indexable insert

- Type 312
N312
S312
U312
US312

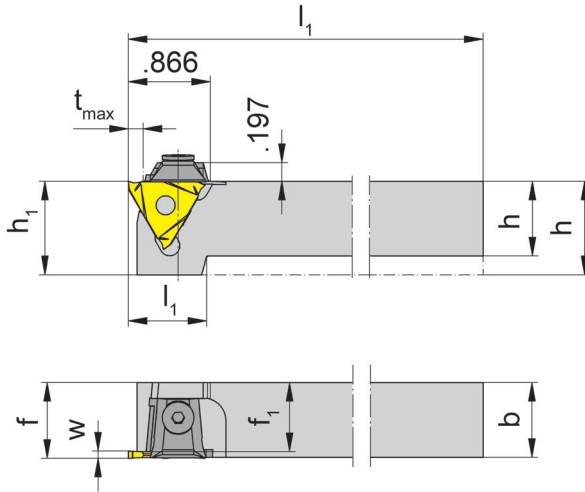

R = right hand version shown

L = left hand version

Part number	h	b	l_1	l_2	h_1	f_1	f	Size	Clamping range
R/LU360.0500.01	.500	.500	3.996	.945	.984	.441	f_1+w-a_1	01	.020 - .075
R/LU360.0625.01	.625	.625	5.118	.866	.984	.566	f_1+w-a_1	01	.020 - .075
R/LU360.0750.01	.750	.750	5.118	.827	.984	.691	f_1+w-a_1	01	.020 - .075
R/LU360.1000.01	1.000	1.000	6.004	-	1.000	.941	f_1+w-a_1	01	.020 - .075
R/LU360.1250.01	1.250	1.250	6.693	-	1.250	1.191	f_1+w-a_1	01	.020 - .075
R/LU360.0500.02	.500	.500	3.996	.945	.984	.402	f_1+w-a_1	02	.075 - .114
R/LU360.0625.02	.625	.625	5.118	.866	.984	.527	f_1+w-a_1	02	.075 - .114
R/LU360.0750.02	.750	.750	5.118	.827	.984	.652	f_1+w-a_1	02	.075 - .114
R/LU360.1000.02	1.000	1.000	6.004	-	1.000	.902	f_1+w-a_1	02	.075 - .114
R/LU360.1250.02	1.250	1.250	6.693	-	1.250	1.152	f_1+w-a_1	02	.075 - .114

State R or L version

w, a_1 see indexable inserts

Dimensions in inch

Further sizes upon request

t_{max} can be reached only with workpiece $\varnothing \leq 1.575''$

For torque specification of the screw, please see Technical Instructions.

Spare Parts

Toolholder	Allen wrench	Clamping element
R/LU360.0500/.0625...	SW3,0 DIN911	11.3
R/LU360...01/.02	SW3,0 DIN911	16.4

O

Toolholder

360

Depth of groove up to
Clamping range

6 mm
0.5 - 2.9 mm

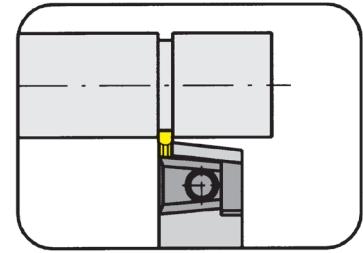

for Indexable insert

Type 312
N312
S312
U312
US312

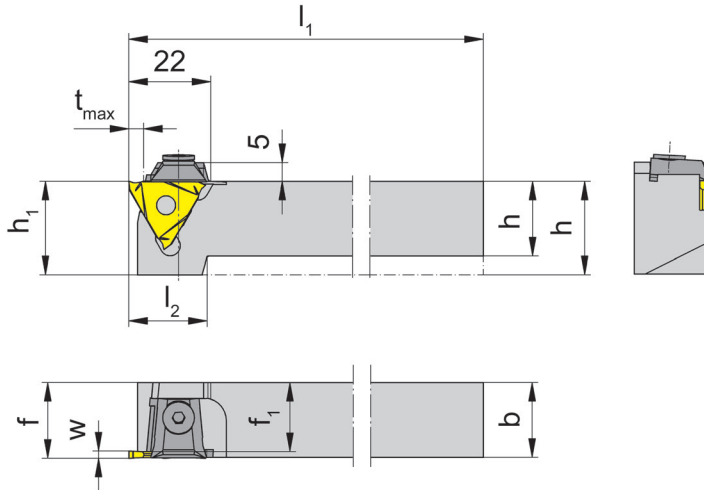

R = right hand version shown

L = left hand version

Part number	h	b	l ₁	l ₂	h ₁	f ₁	f	t _{max}	Size	Clamping range
R/L360.1212.01	12	12	100	24	25	10.5	f ₁ +w-a ₁	4	01	.5-1.9
R/L360.1616.01	16	16	125	22	25	14.5	f ₁ +w-a ₁	4	01	.5-1.9
R/L360.2020.01	20	20	125	21	25	18.5	f ₁ +w-a ₁	4	01	.5-1.9
R/L360.2525.01	25	25	150	-	25	23.5	f ₁ +w-a ₁	4	01	.5-1.9
R/L360.3232.01	32	32	170	-	32	30.5	f ₁ +w-a ₁	4	01	.5-1.9
R/L360.1212.02	12	12	100	24	25	9.5	f ₁ +w-a ₁	6	02	1.9-2.9
R/L360.1616.02	16	16	125	22	25	13.5	f ₁ +w-a ₁	6	02	1.9-2.9
R/L360.2020.02	20	20	125	21	25	17.5	f ₁ +w-a ₁	6	02	1.9-2.9
R/L360.2525.02	25	25	150	-	25	22.5	f ₁ +w-a ₁	6	02	1.9-2.9
R/L360.3232.02	32	32	170	-	32	29.5	f ₁ +w-a ₁	6	02	1.9-2.9

State R or L version

w, a₁ see indexable inserts

Dimensions in mm

Further sizes upon request

t_{max} can be reached only with workpiece Ø ≤ 40 mm

For torque specification of the screw, please see Technical Instructions.

Spare Parts

Toolholder	Allen wrench	Clamping element
R/L360.1212/1616...	SW3,0 DIN911	11.3
R/L360...01/02	SW3,0 DIN911	16.4

O4

Call Us Toll Free (888) 818-4676

Toolholder

U360

Depth of groove up to $.236''$
Clamping range $.114 - .248''$

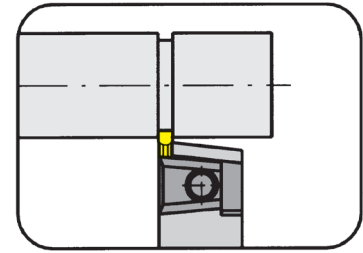

for Indexable insert

- Type 312
N312
S312
U312
US312

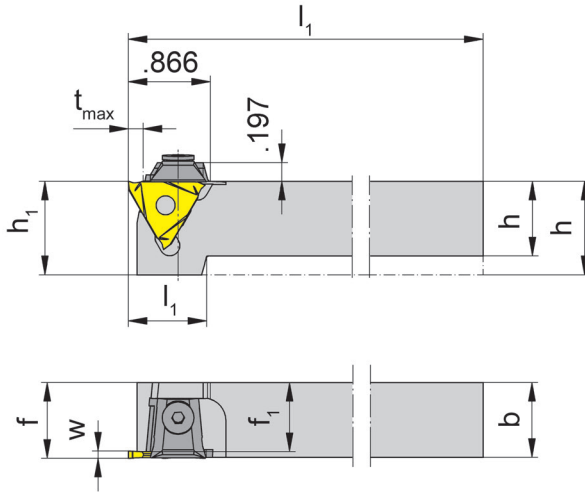

R = right hand version shown

L = left hand version

Part number	h	b	l_1	l_2	h_1	f_1	f	t_{max}	Size	Clamping range
R/LU360.0500.03	.500	.500	3.996	.945	.984	.362	$f_1 + w - a_1$.236	03	.114 - .154
R/LU360.0625.03	.625	.625	5.118	.866	.984	.487	$f_1 + w - a_1$.236	03	.114 - .154
R/LU360.0750.03	.750	.750	5.118	.827	.984	.612	$f_1 + w - a_1$.236	03	.114 - .154
R/LU360.1000.03	1.000	1.000	6.004	-	1.000	.862	$f_1 + w - a_1$.236	03	.114 - .154
R/LU360.1250.03	1.250	1.250	6.693	-	1.250	1.112	$f_1 + w - a_1$.236	03	.114 - .154
R/LU360.0625.04	.625	.625	5.000	.866	.984	.420	$f_1 + w - a_1$.236	04	.154 - .248
R/LU360.0750.04	.750	.750	5.118	.827	.984	.545	$f_1 + w - a_1$.236	04	.154 - .248
R/LU360.1000.04	1.000	1.000	6.000	-	1.000	.795	$f_1 + w - a_1$.236	04	.154 - .248
R/LU360.1250.04	1.250	1.250	6.693	-	1.250	1.045	$f_1 + w - a_1$.236	04	.154 - .248

State R or L version

w, a_1 see indexable inserts

Dimensions in inch

Further sizes upon request

t_{max} can be reached only with workpiece $\varnothing \leq 1.575''$

For torque specification of the screw, please see Technical Instructions.

Spare Parts

Toolholder	Allen wrench	Clamping element
R/LU360.0500/.0625.03	SW3,0 DIN911	11.3
R/LU360.0625.04	SW3,0 DIN911	13.4
R/LU360...03/.04	SW3,0 DIN911	16.4

Toolholder

360

Depth of groove up to
Clamping range

6 mm
0.5 - 2.9 mm

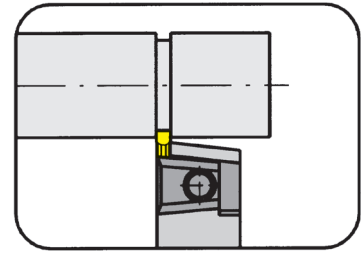

for Indexable insert

Type 312
N312
S312
U312
US312

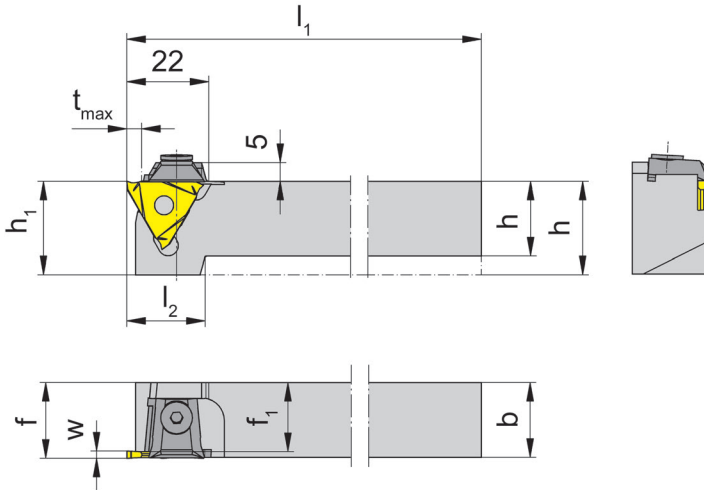

R = right hand version shown

L = left hand version

Part number	h	b	l ₁	l ₂	h ₁	f ₁	f	t _{max}	Size	Clamping range
R/L360.1212.03	12	12	100	24	25	8.5	f ₁ +w-a ₁	6	03	2.9-3.9
R/L360.1616.03	16	16	125	22	25	12.5	f ₁ +w-a ₁	6	03	2.9-3.9
R/L360.2020.03	20	20	125	21	25	16.5	f ₁ +w-a ₁	6	03	2.9-3.9
R/L360.2525.03	25	25	150	-	25	21.5	f ₁ +w-a ₁	6	03	2.9-3.9
R/L360.3232.03	32	32	170	-	32	28.5	f ₁ +w-a ₁	6	03	2.9-3.9
R/L360.1616.04	16	16	125	22	25	10.8	f ₁ +w-a ₁	6	04	3.9-6.3
R/L360.2020.04	20	20	125	21	25	14.8	f ₁ +w-a ₁	6	04	3.9-6.3
R/L360.2525.04	25	25	150	-	25	19.8	f ₁ +w-a ₁	6	04	3.9-6.3
R/L360.3232.04	32	32	170	-	32	26.8	f ₁ +w-a ₁	6	04	3.9-6.3

State R or L version

w, a₁ see indexable inserts

Dimensions in mm

Further sizes upon request

t_{max} can be reached only with workpiece Ø ≤ 40 mm

For torque specification of the screw, please see Technical Instructions.

Spare Parts

Toolholder	Allen wrench	Clamping element
R/L360.1212/.1616...	SW3,0 DIN911	11.3
R/L360.1616.04	SW3,0 DIN911	13.4
R/L360...03/.04	SW3,0 DIN911	16.4

Toolholder

360

Depth of groove up to 6 mm
Clamping range 2.9 - 6.3 mm

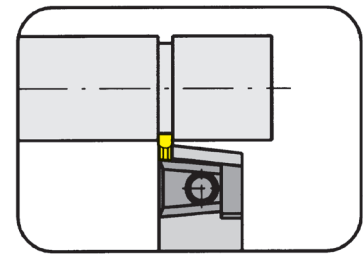

for Indexable insert

Type 312
N312
S312
U312
US312

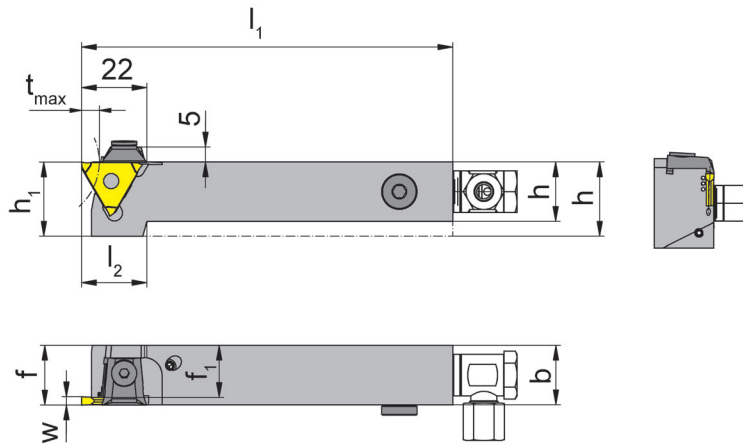

with through coolant supply

R = right hand version shown

L = left hand version

Part number	h	b	l ₁	l ₂	h ₁	f ₁	f	t _{max}	Size	Clamping range
R/L360.1212.01.IK	12	12	100	24	25	10.5	f ₁ +w-a ₁	4	01	.5-1.9
R/L360.1616.01.IK	16	16	125	22	25	14.5	f ₁ +w-a ₁	4	01	.5-1.9
R/L360.2020.01.IK	20	20	125	21	25	18.5	f ₁ +w-a ₁	4	01	.5-1.9
R/L360.2525.01.IK	25	25	150	-	25	23.5	f ₁ +w-a ₁	4	01	.5-1.9
R/L360.1212.02.IK	12	12	100	24	25	9.5	f ₁ +w-a ₁	6	02	1.9-2.9
R/L360.1616.02.IK	16	16	125	22	25	13.5	f ₁ +w-a ₁	6	02	1.9-2.9
R/L360.2020.02.IK	20	20	125	21	25	17.5	f ₁ +w-a ₁	6	02	1.9-2.9
R/L360.2525.02.IK	25	25	150	-	25	22.5	f ₁ +w-a ₁	6	02	1.9-2.9

State R or L version

w, a₁ see indexable inserts

Dimensions in mm

Further sizes upon request

t_{max} can be reached only with workpiece Ø ≤ 40 mm

For torque specification of the screw, please see Technical Instructions.

Spare Parts

Toolholder	Threaded Pin	Allen wrench	Coolant supply	Clamping element	Sealing plug
R/L360.1212.01/.02.IK	3.03.913	SW2,0 DIN911	004.00.61	11.3	
R/L360.1616...	18.05.913	SW3,0 DIN911	004.00.16	11.3	004.00.26
R/L360.2020/.2525...	18.05.913	SW3,0 DIN911	004.00.16	16.4	004.00.26

O

Toolholder

U360

Depth of groove up to
Clamping range

.236"
.114 - .248"

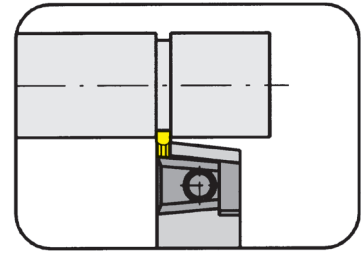

for Indexable insert

Type 312
N312
S312
U312
US312

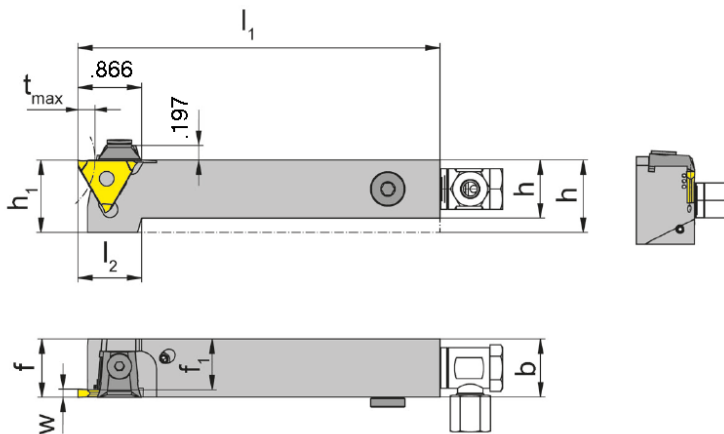

R = right hand version shown

L = left hand version

with through coolant supply

Part number	h	b	l_1	h_1	f_1	f	Size	Clamping range
R/LU360.1000.03.IK	1.000	1.000	6.004	1.000	.862	f_1+w-a_1	03	.114 - .154
R/LU360.1000.04.IK	1.000	1.000	6.004	1.000	.795	f_1+w-a_1	04	.154 - .248

State R or L version

w, a_1 see indexable inserts

Dimensions in inch

Further sizes upon request

t_{max} can be reached only with workpiece $\varnothing \leq 1.575''$

For torque specification of the screw, please see Technical Instructions.

Spare Parts

Toolholder	Sealing plug	Threaded Pin	Allen wrench	Coolant supply	Screw	Clamping element
R/LU360...	004.00.26	3.03.913	SW3,0 DIN911	004.00.16	004.00.21	16.4

Toolholder

360

Depth of groove up to 6 mm
Clamping range 2.9 - 3.9 mm

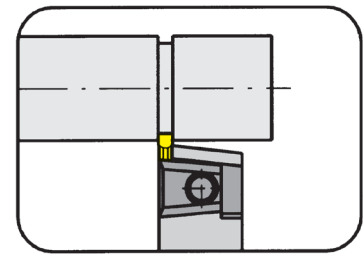

for Indexable insert

Type 312
N312
S312
U312
US312

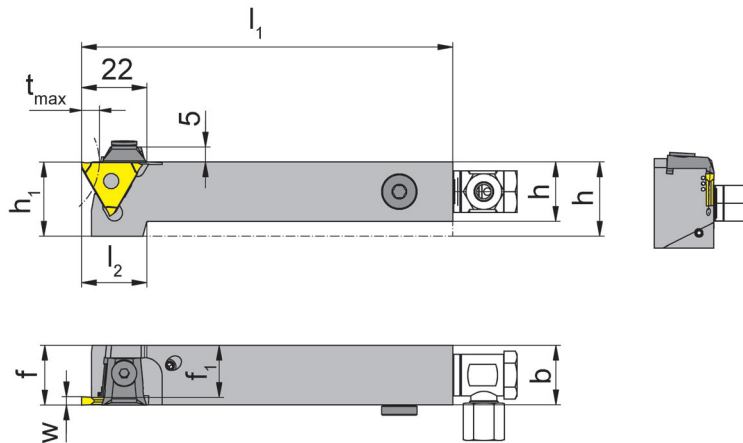

R = right hand version shown

L = left hand version

with through coolant supply

Part number	h	b	l ₁	l ₂	h ₁	f ₁	f	t _{max}	Size	Clamping range
R/L360.1212.03.IK	12	12	100	24	25	8.5	f ₁ +w-a ₁	6	03	2.9-3.9
R/L360.1616.03.IK	16	16	125	22	25	12.5	f ₁ +w-a ₁	6	03	2.9-3.9
R/L360.2020.03.IK	20	20	125	21	25	16.5	f ₁ +w-a ₁	6	03	2.9-3.9
R/L360.2525.03.IK	25	25	150	-	25	21.5	f ₁ +w-a ₁	6	03	2.9-3.9

State R or L version

w, a₁ see indexable inserts

Dimensions in mm

Further sizes upon request

t_{max} can be reached only with workpiece Ø ≤ 40 mm

For torque specification of the screw, please see Technical Instructions.

Spare Parts

Toolholder	Threaded Pin	Allen wrench	Coolant supply	Clamping element	Sealing plug	Screw Plug
R/L360.1212.03.IK	3.03.913	SW2,0 DIN911	004.00.61	11.3		
R/L360.1616.03.IK	18.05.913	SW3,0 DIN911	004.00.16	11.3	004.00.26	
R/L360.2020/.2525...	18.05.913	SW3,0 DIN911	004.00.16	16.4	004.00.26	18.908

Grooving (external)



O

Toolholder

361

reduced head size

Depth of groove up to
Clamping range

6 mm
0.5 - 3.9 mm

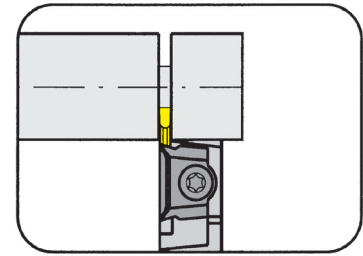

for Indexable insert

Type 312
N312
S312
U312
US312

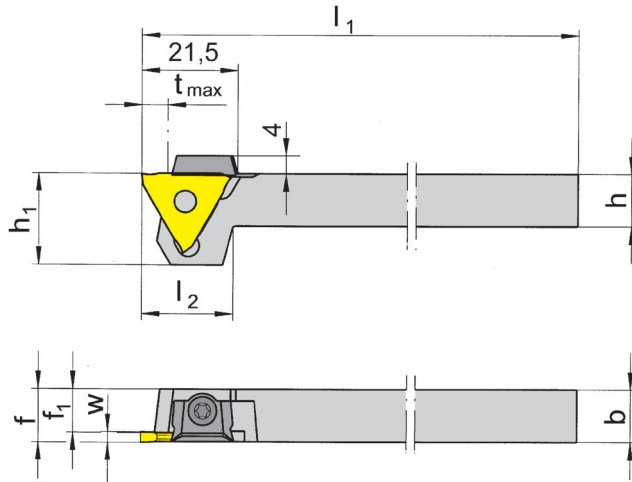

R = right hand version shown

L = left hand version

Part number	h	b	l ₁	l ₂	h ₁	f ₁	f	t _{max}	Size	Clamping range
R/L361.1212.01	12	12	100	17	19	10.5	f ₁ +w-a ₁	4	01	.5-1.9
R/L361.1212.02	12	12	100	17	19	9.5	f ₁ +w-a ₁	6	02	1.9-2.9
R/L361.1212.03	12	12	100	21	21	8.5	f ₁ +w-a ₁	6	03	2.9-3.9

State R or L version

w, a₁ see indexable inserts

Dimensions in mm

Further sizes upon request

t_{max} can be reached only with workpiece Ø ≤ 40 mm

For torque specification of the screw, please see Technical Instructions.

Spare Parts

Toolholder	Clamping element	Clamping Screw	TORX PLUS® Wrench
R/L361...	12.3	030.0422.T10P	T10PL

O10

Call Us Toll Free (888) 818-4676

Toolholder

U368

Depth of groove up to	.315"
Width of groove	.059"

for machines TRAUB (TNL12/7)

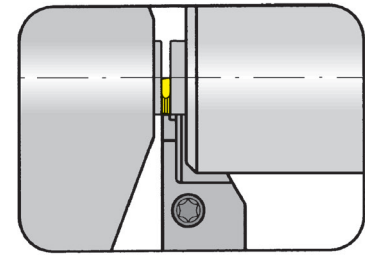

for Indexable insert

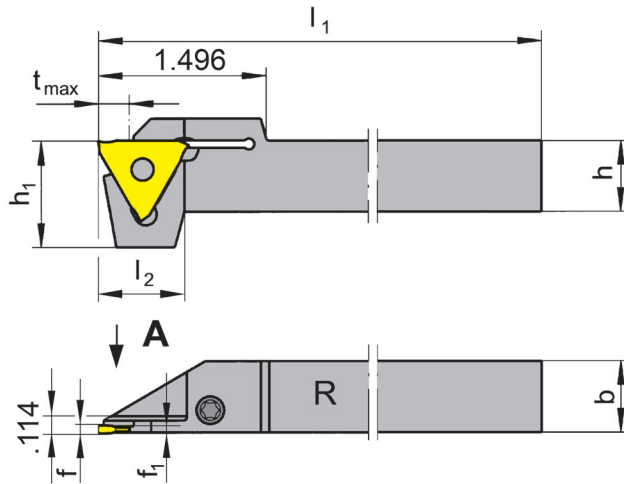

R = right hand version shown

L = left hand version

Type 312
U312

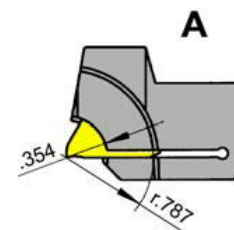

only for peripheral ground profiled inserts

Part number	h	b	l ₁	l ₂	h ₁	f	t _{max}	Size
R/LU368.0500.08	.500	.500	3.996	.768	.945	f ₁ +a ₁	.315	01
R/LU368.0500.11	.500	.500	3.996	.768	.947	f ₁ +a ₁	.315	01
R/LU368.0625.08	.625	.625	5.118	.768	.945	f ₁ +a ₁	.315	01
R/LU368.0625.11	.625	.625	5.118	.768	.947	f ₁ +a ₁	.315	01

State R or L version

a1 see indexable inserts

Dimensions in inch

Toolholder R/L368...08 for indexable inserts:

R/L312.0805... / R/L312.0808... / R/L312.0510... R/L312.0512... / R/L312.1210.../ R/L312.0012...

Toolholder R/L368...11 for indexable inserts:

R/L312.0515... / R/L312.0015...V1

For torque specification of the screw, please see Technical Instructions.

Spare Parts

Toolholder	Clamping Screw	TORX PLUS® Wrench
R/LU368...	4.15T15P	T15PQ

O

Toolholder

368

Depth of groove up to
Width of groove

8 mm
0.5 - 1.5 mm

for machines TRAUB (TNL12/7)

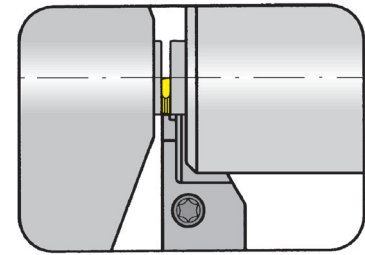

for Indexable insert

Type 312 w<1.5 mm

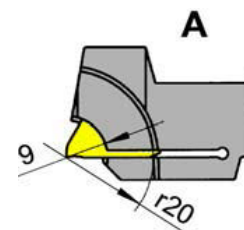
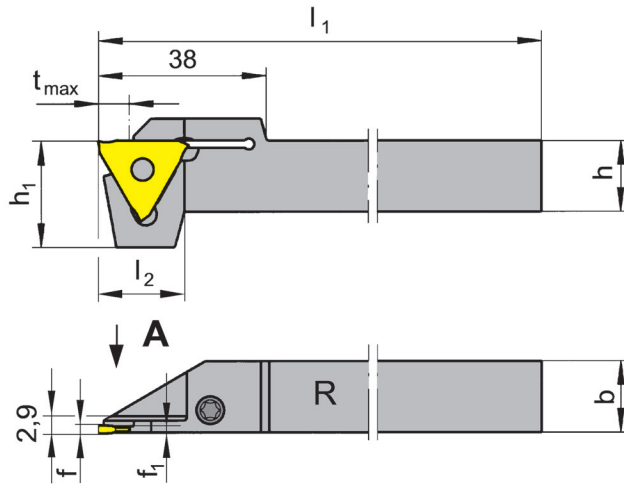

only for peripheral ground
profiled inserts

R = right hand version shown

L = left hand version

Part number	h	b	l ₁	l ₂	h ₁	f ₁	f	t _{max}
R/L368.1212.08	12	12	95	19.5	24	1.0	f ₁ +a ₁	8
R/L368.1616.08	16	16	95	19.5	24	1.0	f ₁ +a ₁	8
R/L368.1212.11	12	12	95	19.5	24	1.3	f ₁ +a ₁	8
R/L368.1616.11	16	16	95	19.5	24	1.3	f ₁ +a ₁	8

State R or L version

a1 see indexable inserts

Dimensions in mm

Toolholder R/L368...08 for indexable inserts:

R/L312.0805... / R/L312.0808... / R/L312.0510... R/L312.0512... / R/L312.1210.../ R/L312.0012...

Toolholder R/L368...11 for indexable inserts:

R/L312.0515... / R/L312.0015...V1

For torque specification of the screw, please see Technical Instructions.

Spare Parts

Toolholder	Clamping Screw	TORX PLUS® Wrench
R/L368...	4.15T15P	T15PQ

O12

Call Us Toll Free (888) 818-4676

Toolholder

368

with through coolant supply

Depth of groove up to
Width of groove

8 mm
0.5 - 1.5 mm

for machines TRAUB (TNL12/7)

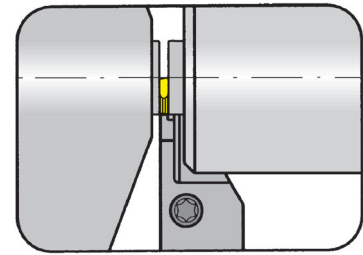

for Indexable insert

Type 312 w<1.5 mm

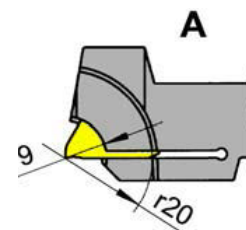
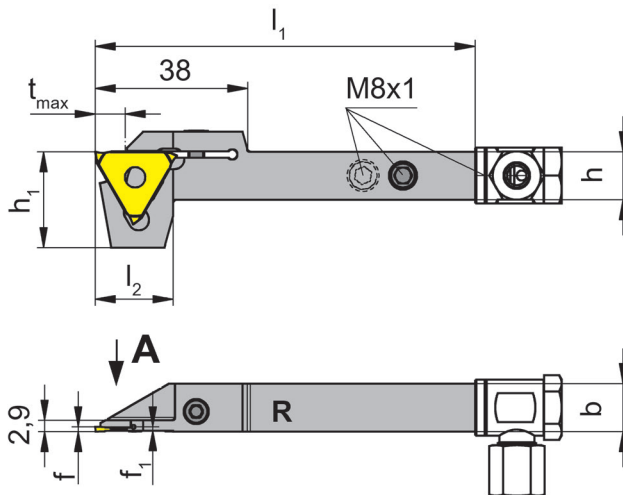

only for periphery ground
profiled inserts

R = right hand version shown

L = left hand version

Part number	h	b	l ₁	l ₂	h ₁	f ₁	f	t _{max}
R/L368.1212.08.IK	12	12	95	19.5	24	1.0	f ₁ +a ₁	8
R/L368.1616.08.IK	16	16	95	19.5	24	1.0	f ₁ +a ₁	8
R/L368.1212.11.IK	12	12	95	19.5	24	1.3	f ₁ +a ₁	8
R/L368.1616.11.IK	16	16	95	19.5	24	1.3	f ₁ +a ₁	8

State R or L version

a1 see indexable inserts

Dimensions in mm

Toolholder R/L368...08.IK for indexable inserts:

R/L312.0805... / R/L312.0808... / R/L312.0510... R/L312.0512... / R/L312.1210... / R/L312.0012...

Toolholder R/L368...11.IK for indexable inserts

R/L312.0515... / R/L312.0015...V1

For torque specification of the screw, please see Technical Instructions.

Spare Parts

Toolholder	Clamping Screw	Threaded Pin	Coolant supply	TORX PLUS® Wrench
R/L368.1212.08/.11.IK	4.15T15P	3.03.913	004.00.61	T15PQ
R/L368.1616.08/.11.IK	4.15T15P	18.05.913	004.00.16	T15PQ

Grooving (external)



O

Toolholder

U369

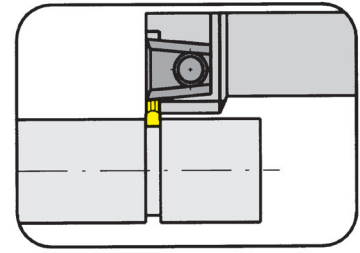

Depth of groove up to .25"
Clamping range .020 - .248"

for Indexable insert

- Type 312
N312
S312
U312
US312

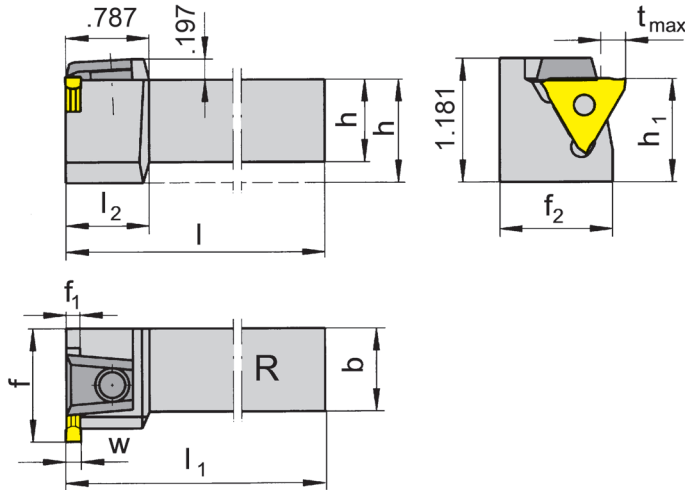

R = right hand version shown

L = left hand version

Part number	h	b	l ₁	h ₁	f	t _{max}	f ₁	f ₂	Size	Clamping range
R/LU369.0750.01	.750	.750	l-f ₁ +w-a ₁	1	1.063	.171	.059	.959	01	.020 - .075
R/LU369.1000.01	1.00	1.00	l-f ₁ +w-a ₁	1	1.260	.171	.059	1.156	01	.020 - .075
R/LU369.0750.02	.750	.750	l-f ₁ +w-a ₁	1	1.063	.250	.098	.919	02	.075 - .114
R/LU369.1000.02	1.00	1.00	l-f ₁ +w-a ₁	1	1.260	.250	.098	1.116	02	.075 - .114
R/LU369.0750.03	.750	.750	l-f ₁ +w-a ₁	1	1.063	.250	.138	.919	03	.114 - .154
R/LU369.1000.03	1.00	1.00	l-f ₁ +w-a ₁	1	1.260	.250	.138	1.116	03	.114 - .154
R/LU369.0750.04	.750	.750	l-f ₁ +w-a ₁	1	1.063	.250	.205	.919	04	.154 - .248
R/LU369.1000.04	1.00	1.00	l-f ₁ +w-a ₁	1	1.260	.250	.205	1.116	04	.154 - .248

State R or L version

w, a₁ see indexable inserts

Dimensions in inch

Further sizes upon request

t_{max} can be reached only with workpiece Ø ≤ 1.575"

For torque specification of the screw, please see Technical Instructions.

Spare Parts

Toolholder	Allen wrench	Clamping element
R/LU369...	SW3,0 DIN911	16.4

Grooving (external)



Toolholder

369

Depth of groove up to 6 mm
Clamping range 0.5 - 6.3 mm

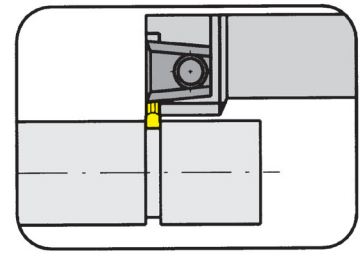

for Indexable insert

- Type 312
N312
S312
U312
US312

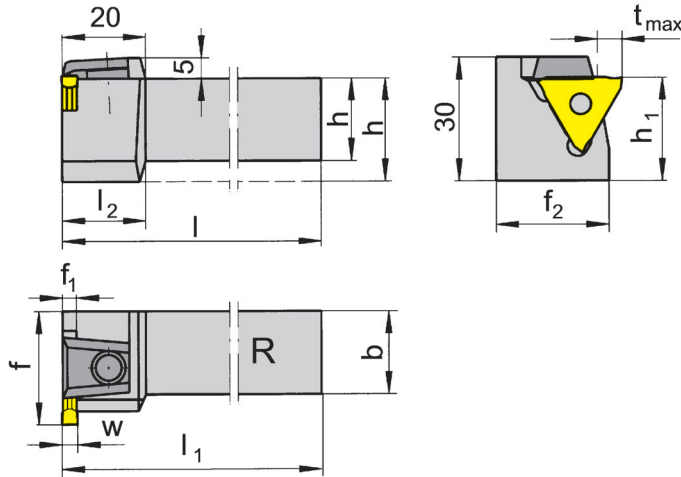

R = right hand version shown

L = left hand version

Part number	h	b	l	l_1	l_2	h_1	f	t_{max}	f_1	f_2	Size	Clamping range
R/L369.2020.01	20	20	125	$l-f_1+w-a_1$	20	25	27	4	1.5	23.5	01	.5-1.9
R/L369.2525.01	25	25	150	$l-f_1+w-a_1$	-	25	32	4	1.5	28.5	01	.5-1.9
R/L369.2020.02	20	20	125	$l-f_1+w-a_1$	20	25	27	6	2.5	23.5	02	1.9-2.9
R/L369.2525.02	25	25	150	$l-f_1+w-a_1$	-	25	32	6	2.5	28.5	02	1.9-2.9
R/L369.2020.03	20	20	125	$l-f_1+w-a_1$	20	25	27	6	3.5	23.5	03	2.9-3.9
R/L369.2525.03	25	25	150	$l-f_1+w-a_1$	-	25	32	6	3.5	28.5	03	2.9-3.9
R/L369.2020.04	20	20	125	$l-f_1+w-a_1$	20	25	27	6	4.5	23.5	04	3.9-6.3
R/L369.2525.04	25	25	150	$l-f_1+w-a_1$	-	25	32	6	4.5	28.5	04	3.9-6.3

State R or L version

w, a_1 see indexable inserts

Dimensions in mm

Further sizes upon request

t_{max} can be reached only with workpiece $\varnothing \leq 40$ mm

For torque specification of the screw, please see Technical Instructions.

Spare Parts

Toolholder	Allen wrench	Clamping element
R/L369...	SW3,0 DIN911	16.4

O

Toolholder

369

Depth of groove
Clamping range

4 - 6 mm
0.5 - 2.9 mm

Hole pattern 13.7 x 37.6 mm

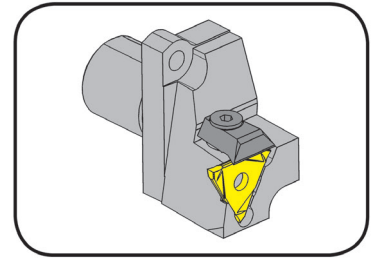

for Indexable insert

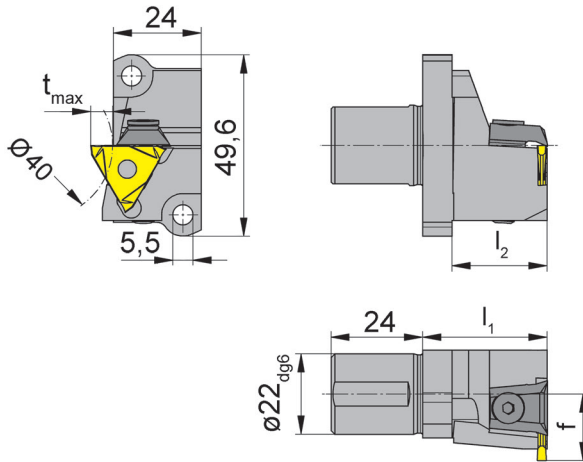

Type 312
N312
S312
U312
US312

for Swiss type machines
Star

L = left hand version shown

Part number	l_2	f	t_{max}	l_1	Size	Clamping range
L369.A022.18.01	26	18.2	4	34	01	.5-1.9
L369.A022.18.02	26	18.2	6	34	02	1.9-2.9

Further sizes upon request

Dimensions in mm

For torque specification of the screw, please see Technical Instructions.

Swiss Type Machines Star: ECAS-12/20, SB16D/E, SR-20, SR20J/JN, RS-20RII, RS-20RIII, RS-20RIV, RS-32J/JN, SW-12RII

Spare Parts

Toolholder	Allen wrench	Clamping element
L369...	SW3,0 DIN911	16.4

Cartridge Graf

64/65

with through coolant supply

Depth of groove
Clamping range

4 mm
0.5 - 2.9 mm

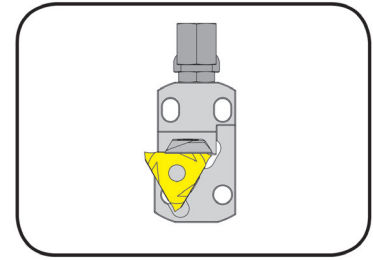

for Indexable insert

Type 312
N312
S312
U312
US312

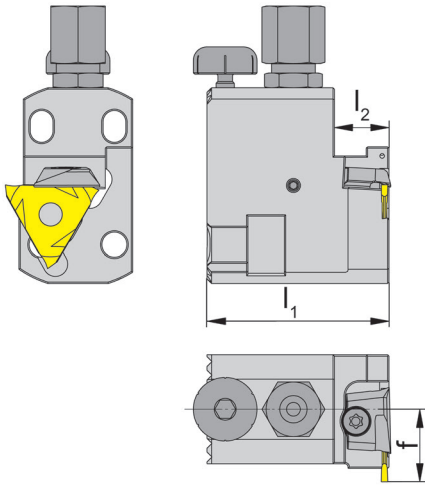

R = right hand version shown

L = left hand version

with through coolant supply

Part number	l_1	l_2	f	Size	Clamping range
R/L64.IK	40	12	16	01	.5-1.9
R/L65.IK	40	12	16	02	1.9-2.9

State R or L version

Dimensions in mm

Further sizes upon request

Coolant tube is not included - separate required!

Spare Parts

Cartridge Graf	Screw to adjust the height	Coolant supply	Clamping element
L6...	002.00.69	004.00.19	4.082L
R6...	002.00.69	004.00.19	4.081R

O

Cartridge Graf

64/65/99

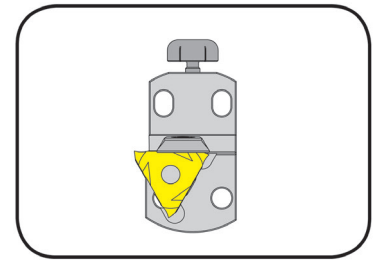

Depth of groove	4 mm
Clamping range	0.5 - 3.9 mm

for Indexable insert

- Type
- 312
 - N312
 - S312
 - U312
 - US312

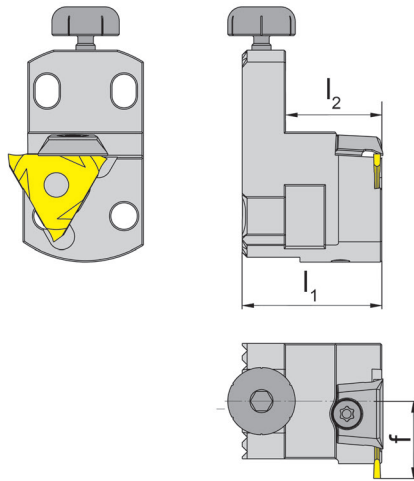

R = right hand version shown

L = left hand version

Part number	l_1	l_2	f	Size	Clamping range
R/L64	29	20	16	01	.5-1.9
R/L65	29	20	16	02	1.9-2.9
R/L99	29	20	16	03	2.9-3.9

State R or L version

Dimensions in mm

Further sizes upon request

Spare Parts

Cartridge Graf	Screw to adjust the height	Clamping element
R/L....	002.00.69	12.3



Adjustable holder

N67/N68/N98

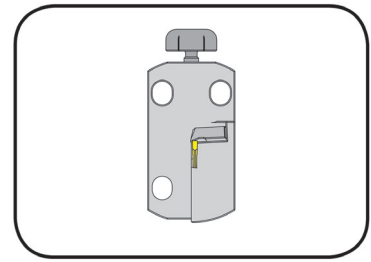

Depth of groove	4 mm
Clamping range	0.5 - 3.9 mm

for Indexable insert

- Type
- 312
 - N312
 - S312
 - U312
 - US312

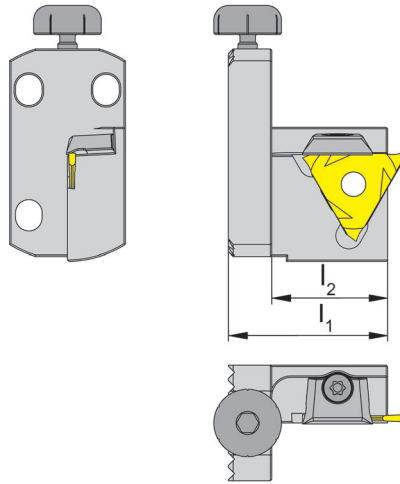

Part number	l_1	l_2	Size	Clamping range
N67	33	29	01	.5-1.9
N68	33	29	02	1.9-2.9
N98	33	29	02	2.9-3.9

Further sizes upon request

Dimensions in mm

Spare Parts

Adjustable holder	Screw to adjust the height	Clamping element
N...	002.00.69	12.3

Grooving (external)



O

Toolholder

U390

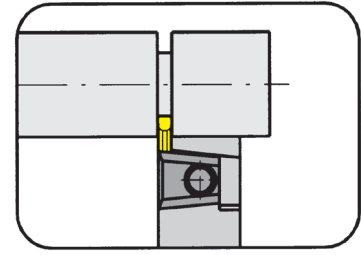

Depth of groove up to $.315''$
Clamping range $.075 - .209''$

for Indexable insert

- Type 312
N312
S312
U312
US312

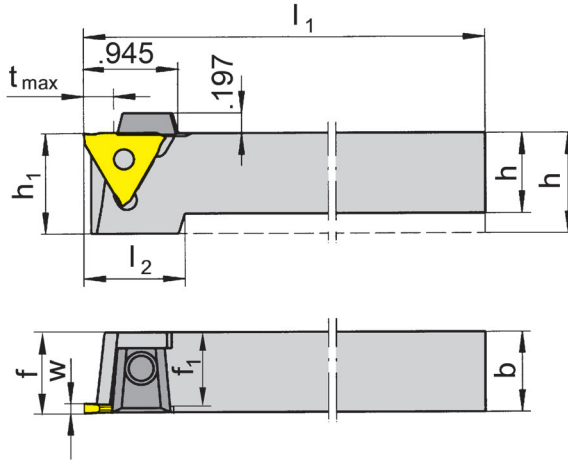

R = right hand version shown

L = left hand version

Part number	h	b	l_1	l_2	h_1	h_1	f	t_{max}	Size	Clamping range
R/LU390.0750.02	.750	.750	5.118	.945	1.000	.652	f_1+w-a_1	.315	02	.075 - .114
R/LU390.1000.02	1.000	1.000	6.004	-	1.000	.902	f_1+w-a_1	.315	02	.075 - .114
R/LU390.1250.02	1.250	1.250	6.004	-	1.250	1.152	f_1+w-a_1	.315	02	.075 - .114
R/LU390.0750.03	.750	.750	5.118	.866	1.000	.612	f_1+w-a_1	.315	03	.114 - .154
R/LU390.1000.03	1.000	1.000	6.004	-	1.000	.862	f_1+w-a_1	.315	03	.114 - .154
R/LU390.1250.03	1.250	1.250	6.693	-	1.250	1.112	f_1+w-a_1	.315	03	.114 - .154
R/LU390.0750.04	.750	.750	5.118	.866	1.000	.545	f_1+w-a_1	.315	04	.154 - .209
R/LU390.1000.04	1.000	1.000	6.004	-	1.000	.795	f_1+w-a_1	.315	04	.154 - .209
R/LU390.1250.04	1.250	1.250	6.693	-	1.25	1.045	f_1+w-a_1	.315	04	.154 - .209

State R or L version

w, a_1 see indexable inserts

Dimensions in inch

Further sizes upon request

$t_{max} = .315''$ can be reached only with workpiece $\varnothing \leq 4.921''$

For torque specification of the screw, please see Technical Instructions.

Spare Parts

Toolholder	Allen wrench	Clamping element
R/LU390...	SW3,0 DIN911	16.4

Grooving (external)



Toolholder

390

Depth of groove up to 8 mm
Clamping range 1.4 - 5.3 mm

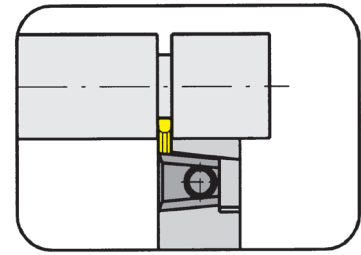

for Indexable insert

Type 312
N312
S312
U312
US312

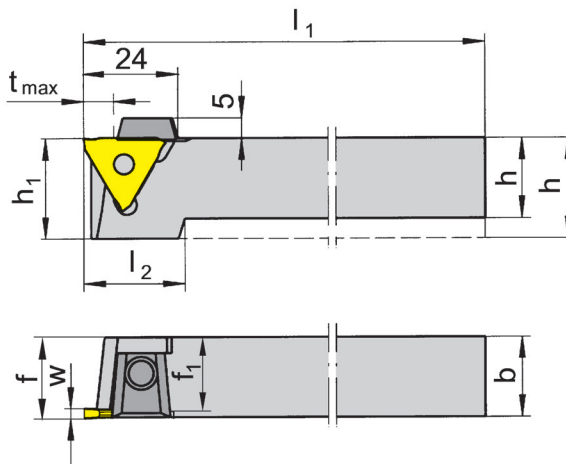

R = right hand version shown

L = left hand version

Part number	h	b	l ₁	l ₂	h ₁	f ₁	f	t _{max}	Size	Clamping range
R/L390.2020.01	20	20	125	22	25	18.5	f ₁ +w-a ₁	8	01	1.4-1.9
R/L390.2525.01	25	25	150	-	25	23.5	f ₁ +w-a ₁	8	01	1.4-1.9
R/L390.2020.02	20	20	125	22	25	17.5	f ₁ +w-a ₁	8	02	1.9-2.9
R/L390.2525.02	25	25	150	-	25	22.5	f ₁ +w-a ₁	8	02	1.9-2.9
R/L390.3232.02	32	32	170	-	32	29.5	f ₁ +w-a ₁	8	02	1.9-2.9
R/L390.2020.03	20	20	125	22	25	16.5	f ₁ +w-a ₁	8	03	2.9-3.9
R/L390.2525.03	25	25	150	-	25	21.5	f ₁ +w-a ₁	8	03	2.9-3.9
R/L390.3232.03	32	32	170	-	32	28.5	f ₁ +w-a ₁	8	03	2.9-3.9
R/L390.2020.04	20	20	125	22	25	14.8	f ₁ +w-a ₁	8	04	3.9-5.3
R/L390.2525.04	25	25	150	-	25	19.8	f ₁ +w-a ₁	8	04	3.9-5.3
R/L390.3232.04	32	32	170	-	32	26.8	f ₁ +w-a ₁	8	04	3.9-5.3

State R or L version

w, a₁ see indexable inserts

Dimensions in mm

Further sizes upon request

t_{max} can be reached only with workpiece Ø ≤ 125 mm

For torque specification of the screw, please see Technical Instructions.

Spare Parts

Toolholder	Allen wrench	Clamping element
R/L390...	SW3,0 DIN911	16.4

Grooving (external)



O

Toolholder

391

Depth of groove up to
Clamping range

8 mm
0.5 - 1.9 mm

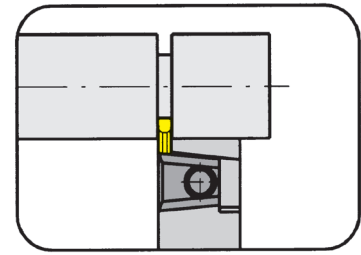

for Indexable insert

Type 312
N312
S312
U312
US312

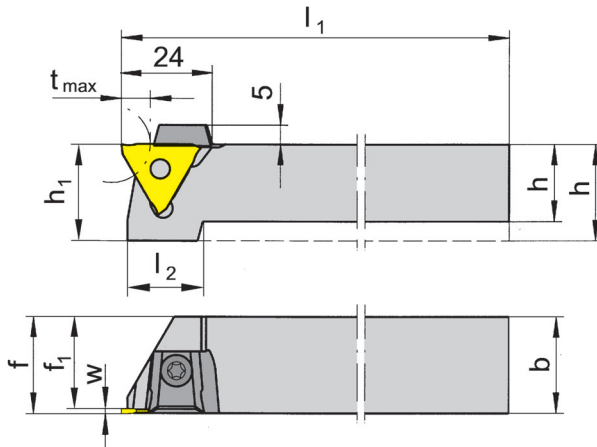

R = right hand version shown

L = left hand version

Part number	h	b	l ₁	l ₂	h ₁	f ₁	f	t _{max}	Size	Clamping range
R/L391.1212.01	12	12	100	21	21	10.5	f ₁ +w-a ₁	8	01	.5-1.9
R/L391.1616.01	16	16	125	21	21	14.5	f ₁ +w-a ₁	8	01	.5-1.9
R/L391.2020.01	20	20	125	21	21	18.5	f ₁ +w-a ₁	8	01	.5-1.9
R/L391.2525.01	25	25	150	-	25	23.8	f ₁ +w-a ₁	8	01	.5-1.9

State R or L version

w, a₁ see indexable inserts

Dimensions in mm

Further sizes upon request

t_{max} can be reached only with workpiece Ø ≤ 20 mm

For torque specification of the screw, please see Technical Instructions.

Spare Parts

Toolholder	Clamping element	TORX PLUS® Wrench	Allen wrench
R/L391.1212.01	12.3	T10PL	
R/L391.1616.01	14.4	T15PQ	
R/L3912020/.2525....	16.4		SW3,0 DIN911

O22

Call Us Toll Free (888) 818-4676

Grooving Corner Reliefs (external)



Toolholder

U309

Corner reliefs similar to DIN 509 form "F"

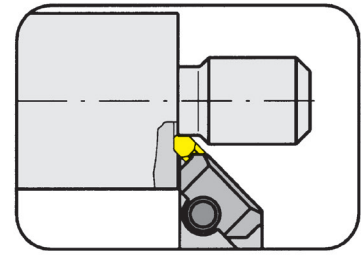

for Indexable insert

Type 312
N312
S312
U312
US312

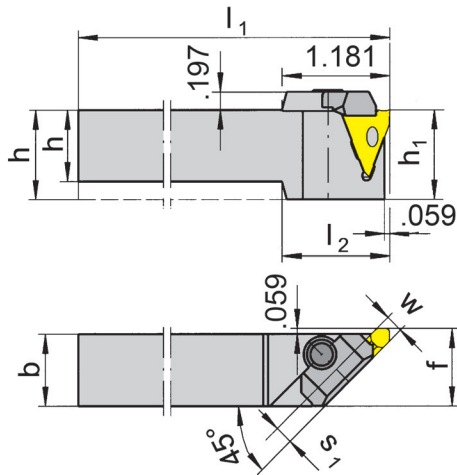

R = right hand version shown

L = left hand version

Part number	h	b	l ₁	l ₂	h ₁	f	s ₁	Size	Clamping range
R/LU309.0750.02	.750	.750	5.118	1.181	1.000	.809	.098	02	.075 - .114
R/LU309.1000.02	1.000	1.000	6.004	-	1.000	1.059	.098	02	.075 - .114
R/LU309.1250.02	1.250	1.250	6.693	-	1.250	1.309	.098	02	.075 - .114
R/LU309.0750.03	.750	.750	5.118	1.181	1.004	.809	.138	03	.114 - .154
R/LU309.1000.03	1.000	1.000	6.004	-	1.001	1.059	.138	03	.114 - .154
R/LU309.1250.03	1.250	1.250	6.693	-	1.251	1.309	.138	03	.114 - .154
R/LU309.0750.04	.750	.750	5.118	1.181	1.001	.809	.205	04	.154 - .209
R/LU309.1000.04	1.000	1.000	6.004	-	1.001	1.059	.205	04	.154 - .209
R/LU309.1250.04	1.250	1.250	6.693	-	1.251	1.309	.205	04	.154 - .209

State R or L version

w see indexable inserts

Dimensions in inch

For torque specification of the screw, please see Technical Instructions.

Spare Parts

Toolholder	Allen wrench	Clamping element
R/LU309...	SW3,0 DIN911	21.4

Grooving Corner Reliefs (external)



O

Toolholder

309

Corner reliefs similar to DIN 509 form "F"

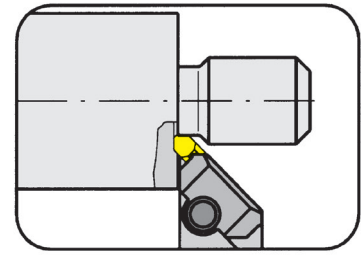

for Indexable insert

Type 312
N312
S312
U312
US312

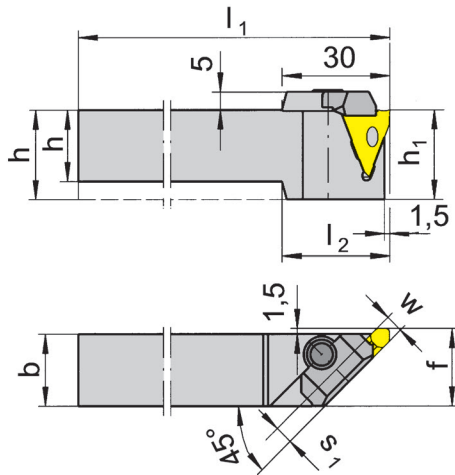

R = right hand version shown

L = left hand version

Part number	h	b	l ₁	l ₂	h ₁	f	s ₁	Size	Clamping range
R/L309.1616.01	16	16	125	30	25	21.5	1.5	01	.5-1.9
R/L309.2020.02	20	20	125	30	25	21.5	2.5	02	1.9-2.9
R/L309.2525.02	25	25	150	-	25	26.5	2.5	02	1.9-2.9
R/L309.3232.02	32	32	170	-	32	33.5	2.5	02	1.9-2.9
R/L309.2020.03	20	20	125	30	25	21.5	3.5	03	2.9-3.9
R/L309.2525.03	25	25	150	-	25	26.5	3.5	03	2.9-3.9
R/L309.3232.03	32	32	170	-	32	33.5	3.5	03	2.9-3.9
R/L309.2020.04	20	20	125	30	25	21.5	5.2	04	3.9-5.3
R/L309.2525.04	25	25	150	-	25	26.5	5.2	04	3.9-5.3
R/L309.3232.04	32	32	170	-	32	33.5	5.2	04	3.9-5.3

State R or L version

w see indexable inserts

Dimensions in mm

For torque specification of the screw, please see Technical Instructions.

Spare Parts

Toolholder	Allen wrench	Clamping element
R/L309...	SW3,0 DIN911	21.4

Grooving (external)



Toolholder

U340

Multi grooving

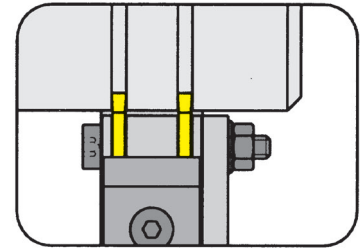

for Indexable insert

Type 312 "G"

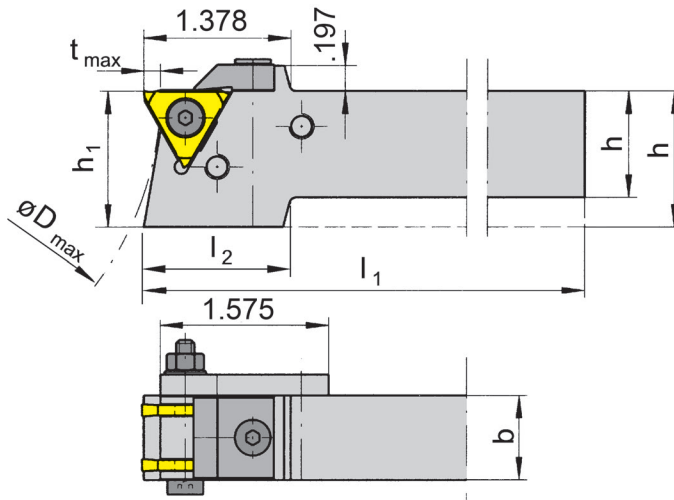

use only with special inserts ground periphery type "G"

Part number	h	b	l ₁	l ₂	h ₁	D _{max}	Size
U340.0750.01	.750	.750	6.693	1.378	1.260	6.299	01
U340.1000.01	1.000	.750	6.693	1.378	1.260	6.299	01
U340.1250.01	1.250	.750	6.693	-	1.250	6.299	01

Further sizes upon request

Dimensions in inch

For torque specification of the screw, please see Technical Instructions.

Tube for producing spacing rings Part number 340.0012.50 separate order required

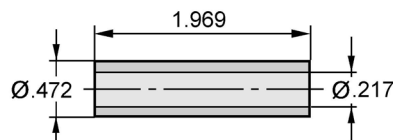

Spare Parts

Toolholder	Clamping Screw	Spring plate	Flange	Thread-Ring	Clamping element	Washer
U340...	5.30.7984	5.12.03	24.40	12.3.8.5	340.0200	B5.3 DIN 125-St

Call Us Toll Free (888) 818-4676

Grooving (external)



O

Toolholder

340

Multi grooving

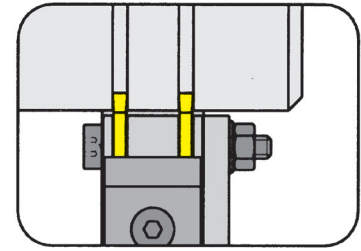

for Indexable insert

Type 312 "G"

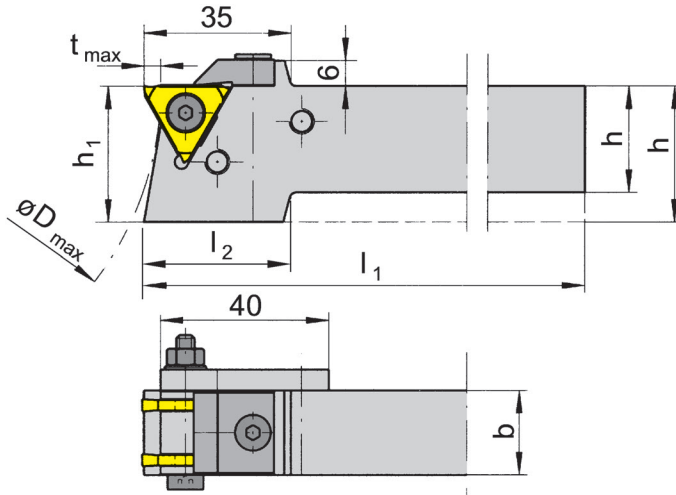

use only with special inserts ground periphery type "G"

Part number	h	b	l ₁	l ₂	h ₁	D _{max}	t _{max}	Size
340.2020.01	20	20	170	35	32	160	4	01
340.2520.01	25	20	170	35	32	160	4	01
340.3220.01	32	20	170	-	32	160	4	01

Further sizes upon request

Dimensions in mm

For torque specification of the screw, please see Technical Instructions.

Tube for producing spacing rings Part number 340.0012.50 separate order required

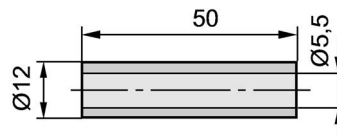

Spare Parts

Toolholder	Clamping Screw	Spring plate	Flange	Thread-Ring	Clamping element	Washer
340...	5.30.7984	5.12.03	24.40	12.3.8.5	340.0200	B5.3 DIN 125-St

Grooving (external)



Toolholder

U340

Multi grooving

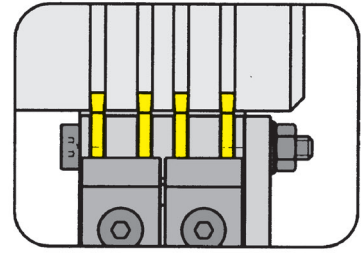

for Indexable insert

Type 312 "G"

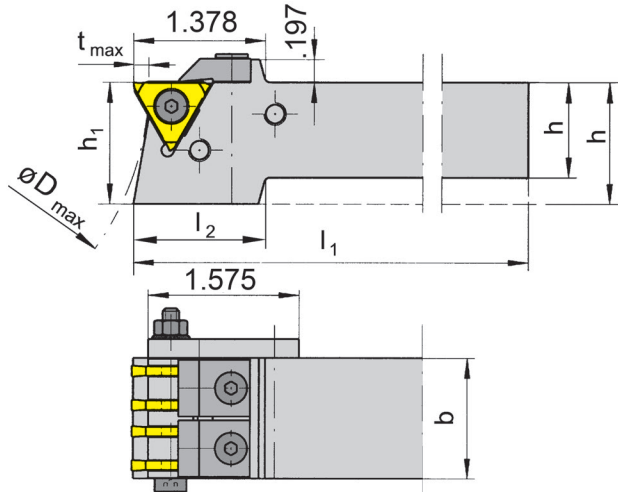

Right hand mounted

use only with special inserts ground periphery type "G"

Part number	h	b	l ₁	l ₂	h ₁	D _{max}	Size
U340.1000.02	1.000	1.250	6.693	1.378	1.250	6.299	02
U340.1250.02	1.250	1.250	6.693	-	1.250	6.299	02

Further sizes upon request

Dimensions in inch

For torque specification of the screw, please see Technical Instructions.

Tube for producing spacing rings Part number 340.0012.50 separate order required

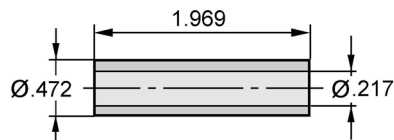

Spare Parts

Toolholder	Wrench	Clamping Screw	Spring plate	Flange	Thread-Ring	Package screw	Clamping Element	Washer
U340...	SW3,0 DIN911	6.16.7991	5.12.03	24.40	12.3.8.5	5.40.7984	22.16	B5.3 DIN 125-St

Grooving (external)



O

Toolholder

340

Multi grooving

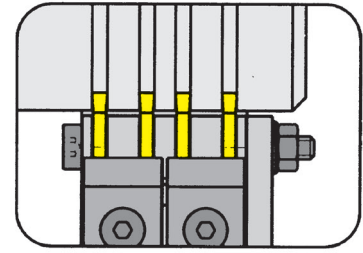

for Indexable insert

Type 312 "G"

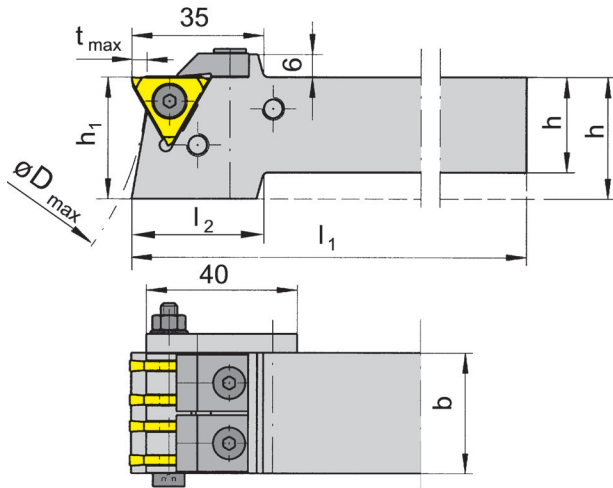

Right hand mounted

use only with special inserts ground periphery type "G"

Part number	h	b	l ₁	l ₂	h ₁	D _{max}	t _{max}	Size
340.2532.02	25	32	170	35	32	160	4	02
340.3232.02	32	32	170	-	32	160	4	02

Further sizes upon request

Dimensions in mm

For torque specification of the screw, please see Technical Instructions.

Tube for producing spacing rings Part number 340.0012.50 separate order required

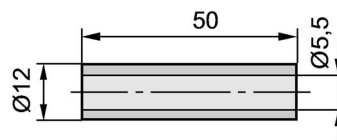

Spare Parts

Toolholder	Wrench	Clamping Screw	Spring Plate	Flange	Thread-Ring	Package Screw	Clamping Element	Washer
340...	SW3,0 DIN911	6.16.7991	5.12.03	24.40	12.3.8.5	5.40.7984	22.16	B5.3 DIN 125-St

Grooving (internal)



Basic toolholder

U330

Bore Ø from Clamping range 1.811" .020 - .248"

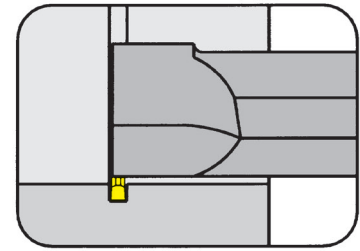

for Indexable insert

Type 312
N312
S312
U312
US312

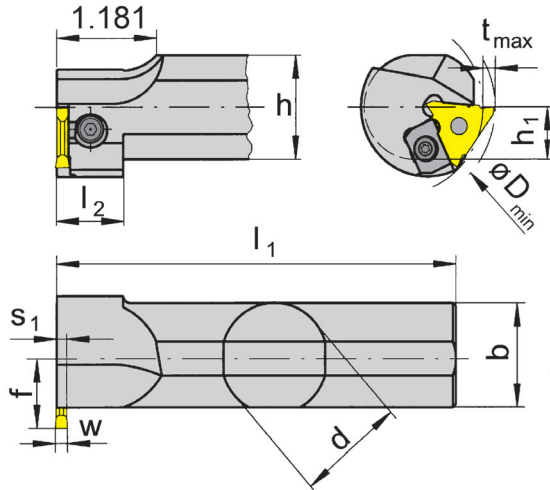

Depth of groove in relation to bore Ø

D _{min}	t _{max}
1.811	.079
1.968	.118
2.362	.157
3.149	.177
3.937	.197

R = right hand version shown

L = left hand version

Part number	d	l ₁	l ₂	h	s ₁	h ₁	f	D _{min}	b	Size	Clamping range
R/LU330.1000.01	1.000	11.732	.787	.921	.059	.461	.787	1.811	1.000	01	.020 - .075
R/LU330.1250.01	1.250	14.016	.787	1.173	.059	.587	.787	1.811	1.176	01	.020 - .075
R/LU330.1500.01	1.500	15.748	.787	1.425	.059	.713	.945	1.811	1.459	01	.020 - .075
R/LU330.1000.K2	1.000	6.614	.787	.921	.098	.461	.787	1.811	1.000	02	.075 - .114
R/LU330.1250.K2	1.250	7.992	.787	1.173	.098	.586	.787	1.811	1.176	02	.075 - .114
R/LU330.1500.K2	1.500	10.000	.787	1.421	.098	.711	.945	1.811	1.459	02	.075 - .114
R/LU330.1000.K3	1.000	6.614	.787	.921	.138	.461	.787	1.811	1.000	03	.114 - .154
R/LU330.1250.K3	1.250	7.992	.787	1.171	.137	.586	.787	1.811	1.171	03	.114 - .154
R/LU330.1500.K3	1.500	10.000	.787	1.425	.138	.713	.945	1.811	1.459	03	.114 - .154
R/LU330.1000.K4	1.000	6.614	.787	.921	.217	.461	.787	1.811	1.000	04	.154 - .248
R/LU330.1250.K4	1.250	7.992	.787	1.173	.217	.587	.787	1.811	1.176	04	.154 - .248
R/LU330.1500.K4	1.500	10.000	.787	1.425	.217	.713	.945	1.811	1.459	04	.154 - .248

State R or L version

w see indexable inserts

Dimensions in inch

Further sizes upon request

For torque specification of the screw, please see Technical Instructions.

Spare Parts

Basic toolholder	Attachment bar	Clamping Screw	Allen wrench	Clamping element	TORX PLUS® Wrench
R/LU330.1...	020.1025.0170	5.12T20P	SW3,0 DIN911	15.4	T20PQ

Grooving (internal)



O

Basic toolholder

330

Bore Ø from
Clamping range

46 mm
1.9 - 6.3 mm

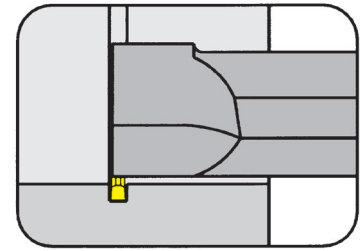

for Indexable insert

Type 312
N312
S312
U312
US312

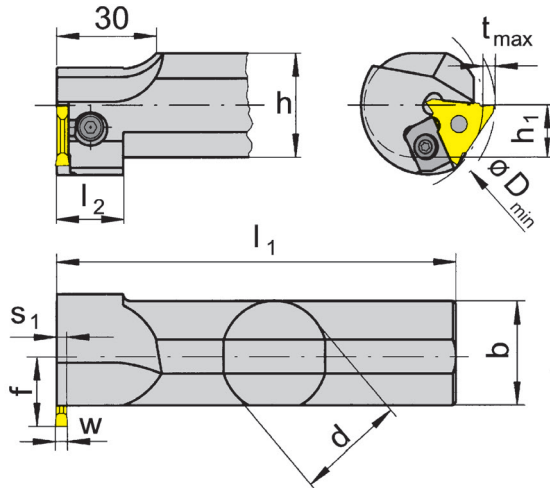

Depth of groove in relation to bore Ø

D _{min}	t _{max}
46	2,0
50	3,0
60	4,0
80	4,5
100	5,0

R = right hand version shown

L = left hand version

Part number	d	l ₁	l ₂	h	s ₁	h ₁	f	D _{min}	b	Size	Clamping range
R/L330.0025.K2	25	170	20	23	2.5	11.5	20	46	25	02	1.9 - 2.9
R/L330.0032.K2	32	200	20	30	2.5	15.0	20	46	30	02	1.9 - 2.9
R/L330.0040.K2	40	250	-	38	2.5	19.0	24	46	38	02	1.9 - 2.9
R/L330.0025.K3	25	170	20	23	3.5	11.5	20	46	25	03	2.9 - 3.9
R/L330.0032.K3	32	200	20	30	3.5	15.0	20	46	30	03	2.9 - 3.9
R/L330.0040.K3	40	250	-	38	3.5	19.0	24	46	38	03	2.9 - 3.9
R/L330.0025.K4	25	170	20	23	5.5	11.5	20	46	25	04	3.9 - 6.3
R/L330.0032.K4	32	200	20	30	5.5	15.0	20	46	30	04	3.9 - 6.3
R/L330.0040.K4	40	250	20	38	5.5	19.0	24	46	38	04	3.9 - 6.3

State R or L version

w see indexable inserts

Dimensions in mm

Further sizes upon request

For torque specification of the screw, please see Technical Instructions.

Spare Parts

Toolholder	Attachment bar	Clamping Screw	Allen wrench	Clamping element	TORX PLUS® Wrench
R/L330...	020.1025.0170	5.12T20P	SW3,0 DIN911	15.4	T20PQ

O30

Call Us Toll Free (888) 818-4676

Indexable insert

S312

with sintered geometries

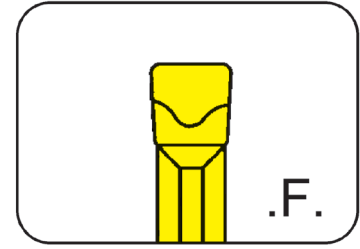

Width of groove .079 - .197"

for Toolholder

- Type
- 309/U309
 - 340/U340
 - 360/U360
 - 361
 - 368/U368
 - 390/U390
 - 391
 - 369/U369
 - 330/U330
 - 360C/360TS
 - 64/65/99
 - N67/N68/N98

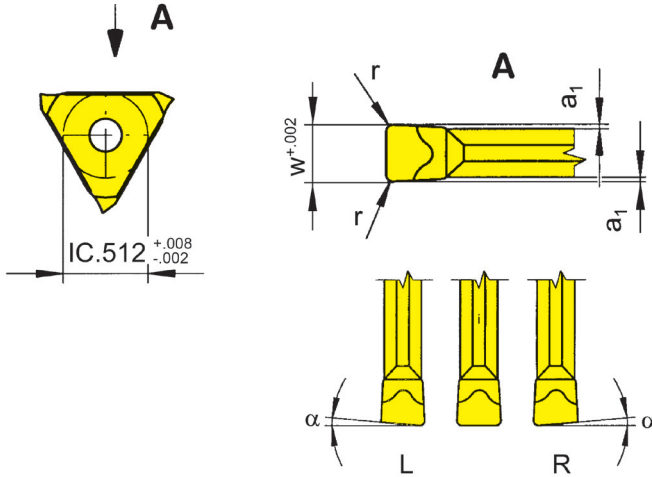

R = right hand version shown

L = left hand version

Geometry .F

Part number	w	r	α	a ₁	Size	Carbide grades					
						AL96	EG56	TC92	TF45	TF46	TI25
R/LS312.0520.F2	.079	.008	5°	.010	02		Δ/Δ			▲/▲	▲/▲
S312.0200.F2	.079	.008	0°	.010	02	x	▲	x	x	▲	▲
R/LS312.0525.F2	.098	.008	5°	.010	02		▲/Δ			▲/x	▲/▲
S312.0250.F2	.098	.008	0°	.010	02	x	Δ	x	x	▲	▲
S312.0400.F2	.157	.008	0°	.010	04		Δ			▲	x
S312.0400.F4	.157	.016	0°	.010	04		▲			▲	▲
S312.0500.F2	.197	.008	0°	.010	04		▲			▲	▲
S312.0500.F4	.197	.016	0°	.010	04		Δ			▲	▲
						P	•	•	•	•	•
						M	-	o	-	o	•
						K	•	o	-	•	•
						N	•	-	-	•	•
						S	-	-	-	o	•
						H	-	-	-	-	-

▲ on stock Δ 4 weeks x upon request
 • recommended
 o alternative recommendation
 - not suitable
 □ uncoated grades
 ■ coated grades
 ■ brazed/Cermet

Dimensions in inch

State R or L version

Indexable inserts can be used in right and left hand toolholders.

Grooving (external and internal)



O

Indexable insert

US312

with sintered geometries

Width of groove .094 - .125"

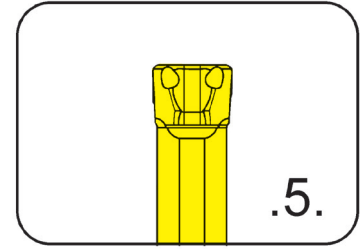

for Toolholder

- Type
- 309/U309
 - 340/U340
 - 360/U360
 - 361
 - 368/U368
 - 390/U390
 - 391
 - 369/U369
 - 330/U330
 - 360C/360TS
 - 64/65/99
 - N67/N68/N98

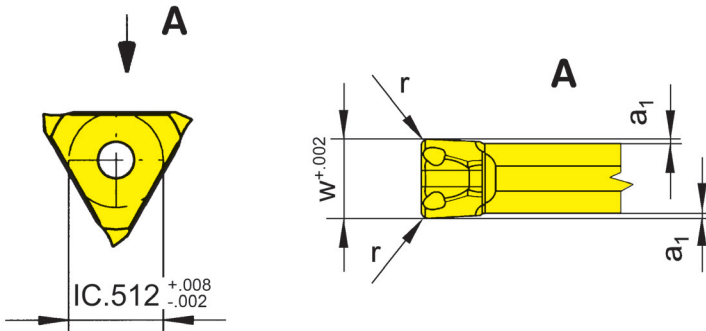

Geometry .5

Part number	w	r	a ₁	Size	TF46
US312.0094.58	.094	.008	.010	02	▲
US312.0125.58	.125	.008	.010	03	▲

- ▲ on stock Δ 4 weeks x upon request
 - recommended
 - alternative recommendation
 - not suitable
 - uncoated grades
 - coated grades
 - brazed/Cermet
- Dimensions in inch

P	●
M	○
K	●
N	●
S	○
H	-

Carbide grades

Indexable inserts can be used in right and left hand toolholders.

Grooving (external and internal)



Indexable insert

S312

with sintered geometries

Width of groove

.098 - .197"

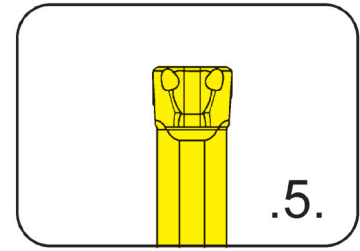

for Toolholder

Type 309/U309
340/U340
360/U360
361
368/U368
390/U390
391
369/U369
330/U330
360C/360TS
64/65/99
N67/N68/N98

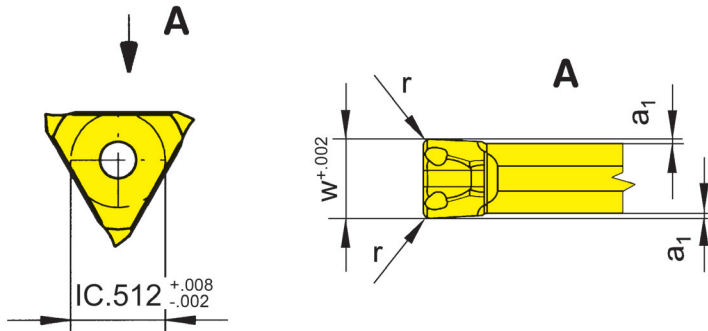

Geometry .5

Part number	w	r	a ₁	Size	AL96	AS62	AS66	EG56	TC92	TF45	TF46	TI25	TN32	TN35
S312.0250.52	.098	.008	.010	02	▲	▲	▲	▲	x	▲	▲	▲	▲	
S312.0250.54	.098	.016	.010	02	x	▲	▲	▲	x	▲	▲	▲	▲	▲
S312.0300.52	.118	.008	.010	03	x	▲	▲	▲	▲	▲	▲	▲	▲	
S312.0300.54	.118	.016	.010	03	x	▲	▲	▲	x	x	▲	▲	▲	
S312.0400.52	.157	.008	.010	04		▲	▲	▲			▲	▲		x
S312.0400.54	.157	.016	.010	04		▲	▲	▲			▲	▲	▲	
S312.0500.52	.197	.008	.010	04		▲	▲	▲			▲	x	▲	
S312.0500.54	.197	.016	.010	04		▲	▲	Δ			▲	▲	x	
					P	●	●	●	●	●	●	●	●	●
					M	-	-	o	o	-	o	o	-	o
					K	●	-	●	o	-	●	●	-	●
					N	●	-	●	-	-	●	●	-	●
					S	-	-	o	-	-	o	o	-	o
					H	-	-	-	-	-	-	-	-	-

▲ on stock Δ 4 weeks x upon request
● recommended
o alternative recommendation
- not suitable
■ uncoated grades
■ coated grades
■ brazed/Cermet

Dimensions in inch

Carbide grades

Indexable inserts can be used in right and left hand toolholders.

O

Indexable insert

US312

with sintered geometries

Width of groove .094 - .125"

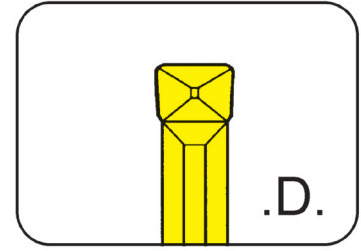

for Toolholder

- Type
- 309/U309
 - 340/U340
 - 360/U360
 - 361
 - 368/U368
 - 390/U390
 - 391
 - 369/U369
 - 330/U330
 - 360C/360TS
 - 64/65/99
 - N67/N68/N98

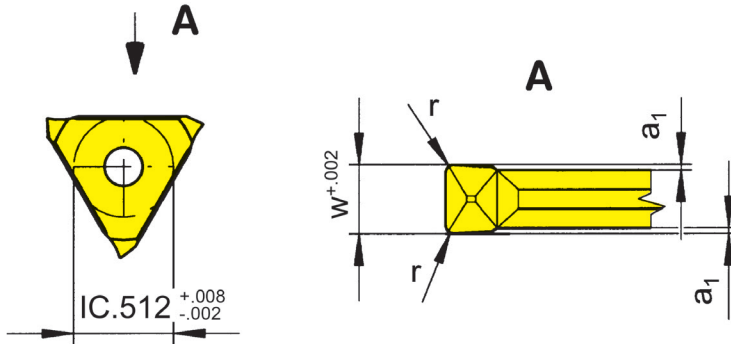

Geometry .D

Part number	w	r	a ₁	Size	Carbide grades		
					TF45	TF46	TI25
US312.0094.D16	.094	.016	.010	02			▲
US312.0094.D8	.094	.008	.010	02		▲	
US312.0125.D8	.125	.008	.014	03	▲	▲	
US312.0125.D8	.125	.008	.014	03	▲	▲	
					P	•	•
					M	•	○
					K	•	•
					N	•	•
					S	•	○
					H	-	-

▲ on stock Δ 4 weeks x upon request
 ● recommended
 ○ alternative recommendation
 - not suitable
 □ uncoated grades
 ■ coated grades
 ■ brazed/Cermet

Dimensions in inch

Indexable inserts can be used in right and left hand toolholders.

Indexable insert

S312

with sintered geometries

Width of groove

.079 - .118"

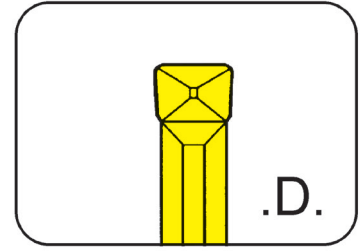

for Toolholder

Type 309/U309
340/U340
360/U360
361
368/U368
390/U390
391
369/U369
330/U330
360C/360TS
64/65/99
N67/N68/N98

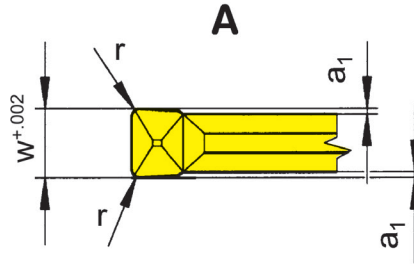
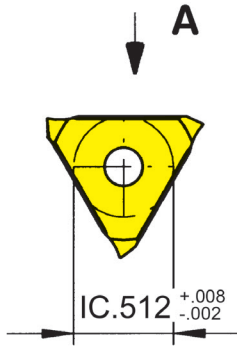

Geometry .D

Part number	w	r	a ₁	Size	Carbide grades								
					AL96	AS62	AS66	EG56	TC92	TF45	TF46	TI25	TN32
S312.0200.D2	.079	.008	.010	02	x	▲	▲	▲	x	Δ	▲	▲	▲
S312.0200.D4	.079	.016	.010	02	x	▲	▲	▲	x	x	x	▲	▲
S312.0250.D2	.098	.008	.010	02	x	▲	▲	▲	▲	▲	▲	▲	▲
S312.0250.D4	.098	.016	.010	02	x	▲	▲	▲	▲	▲	▲	▲	▲
S312.0300.D2	.118	.008	.010	03	x	▲	▲	▲	x	▲	▲	▲	▲
S312.0300.D4	.118	.016	.010	03	x	▲	▲	▲	x	x	x	x	▲
P	●	●	●	●	●	●	●	●	●	●	●	●	●
M	-	-	o	o	-	●	o	●	-	●	o	●	-
K	●	-	●	o	-	●	●	●	-	●	●	●	-
N	●	-	●	-	-	●	●	●	-	●	●	●	-
S	-	-	o	-	-	-	o	-	-	o	o	●	-
H	-	-	-	-	-	-	-	-	-	-	-	-	-

▲ on stock Δ 4 weeks x upon request
● recommended
o alternative recommendation
- not suitable
■ uncoated grades
■ coated grades
■ brazed/Cermet
Dimensions in inch

Carbide grades

Indexable inserts can be used in right and left hand toolholders.

O

Indexable insert

S312

with sintered geometries

Depth of groove up to
Width of groove

.197"
.079 - .118"

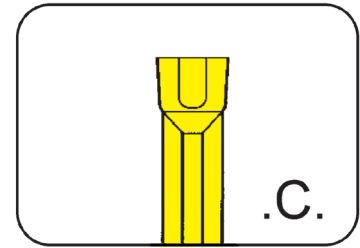

for Toolholder

- Type
- 309/U309
 - 340/U340
 - 360/U360
 - 361
 - 368/U368
 - 390/U390
 - 391
 - 369/U369
 - 330/U330
 - 360C/360TS
 - 64/65/99
 - N67/N68/N98

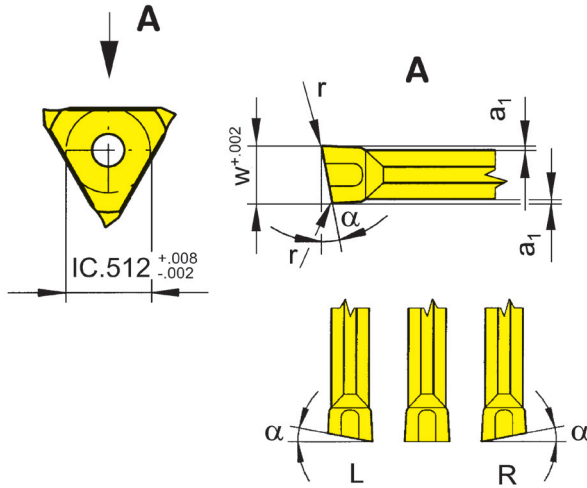

R = right hand version shown

L = left hand version

Geometry .C

Part number	w	r	α	a ₁	Size	Carbide grades		
						EG55	TF46	TI25
S312.0200.C2	.079	.008	0°	.010	02	▲	▲	▲
R/LS312.0520.C2	.079	.008	5°	.010	02	▲/▲	▲/▲	▲/▲
S312.0250.C2	.098	.008	0°	.010	02	▲	▲	▲
R/LS312.0525.C2	.098	.008	5°	.010	02	▲/▲	▲/▲	▲/▲
S312.0300.C2	.118	.008	0°	.010	03	▲	▲	▲
R/LS312.0530.C2	.118	.008	5°	.010	03	▲/▲	▲/x	▲/▲
▲ on stock Δ 4 weeks x upon request						P	•	•
● recommended						M	○	○
○ alternative recommendation						K	○	○
- not suitable						N	-	•
■ uncoated grades						S	-	○
■ coated grades						H	-	-
■ brazed/Cermet								

Dimensions in inch

State R or L version

Indexable inserts can be used in right and left hand toolholders.

Grooving (external)



Indexable insert

312

with round chip breaker

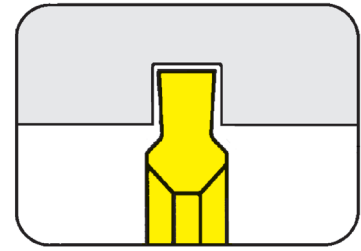

Circlip grooves
Width of circlip Nw

DIN 471/472
.013 - .039"

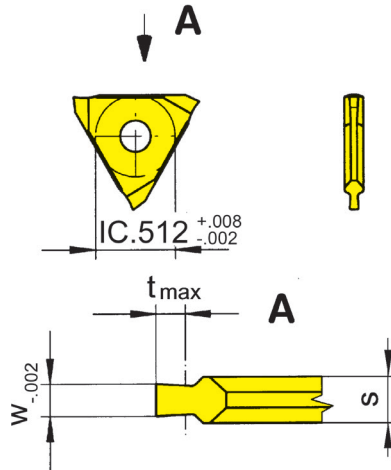

for Toolholder

Type 309/U309
340/U340
360/U360
361
368/U368
390/U390
391
369/U369
330/U330
360C/360TS
64/65/99
N67/N68/N98

Indexability length
± .0008"

Part number	w	Nw	t _{max}	s	Size	Carbide grades			
						EG35	EG52	TN32	
312.0034.15	.015	.013	.024	.059	01	Δ			
312.0044.15	.017	.016	.028	.059	01	Δ			
312.0050.15	.022	.020	.028	.059	01		▲	▲	
312.0060.15	.026	.024	.031	.059	01		▲	▲	
312.0070.15	.030	.028	.043	.059	01		▲	▲	
312.0080.15	.034	.031	.047	.059	01		▲	▲	
312.0090.15	.038	.035	.055	.059	01		▲	▲	
312.0100.15	.042	.039	.063	.059	01		▲	▲	
						P	●	●	●
						M	●	○	-
						K	○	-	-
						N	-	-	-
						S	-	-	-
						H	-	-	-

▲ on stock Δ 4 weeks x upon request
● recommended
○ alternative recommendation
- not suitable
■ uncoated grades
■ coated grades
■ brazed/Cermet

Dimensions in inch

Indexable inserts can be used in right and left hand toolholders.

Further sizes upon request

Grooving (external and internal)



O

Indexable insert

U312

with round chip breaker

Circlip grooves
Width of groove

DIN 471/472
.026 - .250"

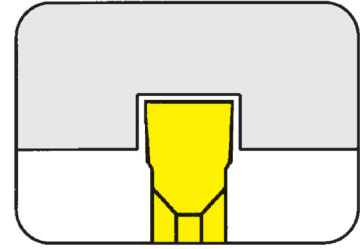

for Toolholder

- Type
- 309/U309
 - 340/U340
 - 360/U360
 - 361
 - 368/U368
 - 390/U390
 - 391
 - 369/U369
 - 330/U330
 - 360C/360TS
 - 64/65/99
 - N67/N68/N98

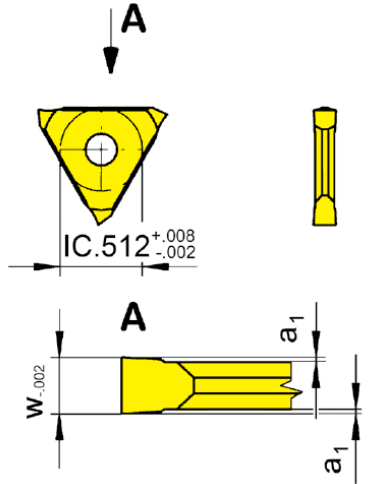

Form A = completely ground

Form B = partially ground

Indexability length
± .0008"

Part number	w	a ₁	Size	MG12	TF45	TF46	T125	TN32	TN35
U312.0026.00	.026	.003	01			▲	▲		
U312.0031.00	.031	.003	01	▲	▲	▲	▲	▲	
U312.0034.00	.034	.003	01			▲			
U312.0040.00	.040	.003	01	▲		▲	▲	▲	
U312.0046.00	.046	.008	01		▲	▲	▲		
U312.0056.00	.056	.008	01	▲		▲	▲		
U312.0062.00	.062	.008	01		▲	▲	▲	▲	▲
U312.0078.00	.078	.008	02	▲	▲	▲	▲	▲	
U312.0088.00	.088	.008	02		▲	▲	▲		
U312.0094.00	.094	.008	02		▲	▲			
U312.0125.00	.125	.008	03	▲	▲	▲		▲	
U312.0157.00	.157	.008	03			▲	▲		
U312.0188.00	.188	.008	04			▲			
U312.0250.00	.250	.008	04				▲		

- ▲ on stock Δ 4 weeks x upon request
- recommended
- alternative recommendation
- not suitable
- uncoated grades
- coated grades
- brazed/Cermet

	P	M	K	N	S	H
MG12	○	●	●	●	●	●
TF45	-	●	○	●	-	●
TF46	-	●	●	●	-	●
T125	-	●	●	●	-	●
TN32	-	●	○	●	-	●
TN35	-	-	-	-	-	-

Dimensions in inch

Carbide grades

Indexable inserts can be used in right and left hand toolholders.

Grooving (external and internal)



Indexable insert

312

with round chip breaker

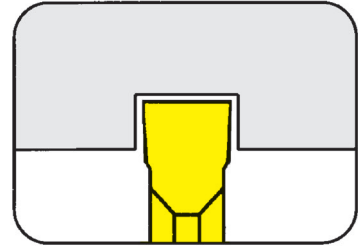

Circlip grooves
Width of circlip Nw

DIN 471/472
.020 - .203"

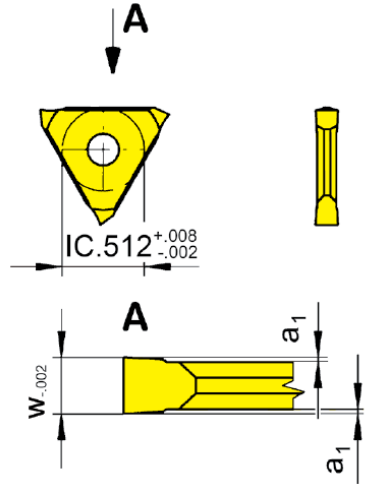

Form A = completely ground

Form B = partially ground

for Toolholder

- Type
- 309/U309
 - 340/U340
 - 360/U360
 - 361
 - 368/U368
 - 390/U390
 - 391
 - 369/U369
 - 330/U330
 - 360C/360TS
 - 64/65/99
 - N67/N68/N98

Indexability length
± .0008"

Part number	w	Nw	a ₁	Size	K10	MG12	P20	EG35	EG55	EG56	HS32	HS36	TA45	TC92	TF45	TF46	TI25	TN32	TN35	H20
312.0050.00	.022	.020	.003	01	▲		▲		▲						▲	▲		▲		
312.0100.00	.042	.039	.004	01	▲		▲		▲						▲	▲		▲	▲	x
312.0060.00	.026	.024	.003	01	▲		▲		▲						▲	▲		▲		
312.0130.00	.057	.051	.008	01	▲		▲		▲					▲	▲	▲		▲	▲	
312.0070.00	.030	.028	.003	01	▲		▲		▲						▲	▲		▲		
312.0080.00	.034	.031	.003	01	▲		▲		▲						▲	▲		▲		
312.0090.00	.038	.035	.003	01	▲		▲		▲						▲	▲		▲	▲	
312.0110.00	.049	.043	.008	01	▲		▲		▲		Δ	Δ			▲	▲		▲		
312.0160.00	.069	.063	.008	01	▲		▲		▲						▲	▲		▲	▲	
312.0185.00	.078	.073	.008	01	▲	▲	▲		▲	Δ					▲	▲	▲	▲	▲	▲
312.0215.00	.090	.085	.008	02	▲	▲	▲		▲				▲		▲	▲		▲	▲	▲
312.0265.00	.110	.104	.008	02	▲	▲	▲		▲				x		▲	▲		▲	▲	▲
312.0315.00	.130	.124	.008	03	▲		▲		▲						▲	▲		▲	▲	▲
312.0415.00	.169	.163	.008	04	▲		▲		▲						▲	▲		▲	▲	▲
312.0515.00	.208	.203	.008	04	▲		▲	▲	▲					Δ	▲	▲		▲	▲	▲

▲ on stock Δ 4 weeks x upon request

- recommended
- alternative recommendation
- not suitable

- uncoated grades
- coated grades
- brazed/Cermet

Dimensions in inch

	P	M	K	N	S	H
●	●	○	●	●	●	●
○	○	-	-	○	○	○
●	●	-	-	○	○	○
○	○	-	-	○	○	○
○	○	-	-	○	○	○
○	○	-	-	○	○	○
○	○	-	-	○	○	○

Carbide grades

Indexable inserts can be used in right and left hand toolholders.

Grooving (external and internal)



O

Indexable insert

312

with round chip breaker

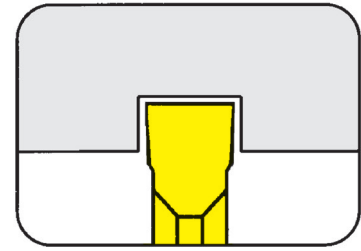

Circlip grooves
Width of circlip Nw

DIN 471/472
.073 - .203"

for Toolholder

- Type
- 309/U309
 - 340/U340
 - 360/U360
 - 361
 - 368/U368
 - 390/U390
 - 391
 - 369/U369
 - 330/U330
 - 360C/360TS
 - 64/65/99
 - N67/N68/N98

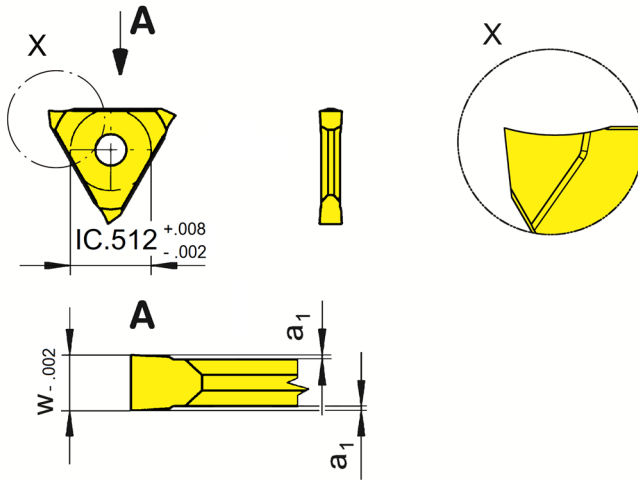

completely ground

Indexability length
± .0008"

Part number	w	Nw	a ₁	Size	Carbide grades				
					K10	P20	EG56	TN32	
312.0185.10	.078	.073	.008	01	▲	▲	▲	▲	
312.0215.10	.090	.085	.008	02	▲	▲	▲	▲	
312.0265.10	.110	.104	.008	02	▲	▲	▲	▲	
312.0315.10	.130	.124	.008	03	▲	x	▲	▲	
312.0415.10	.169	.163	.008	04	▲	▲	▲	▲	
312.0515.10	.208	.203	.008	04	▲	▲	▲	▲	
					P	●	●	●	●
					M	○	-	○	-
					K	●	-	○	-
					N	●	-	-	-
					S	○	-	-	-
					H	-	-	-	-

▲ on stock Δ 4 weeks x upon request

● recommended

○ alternative recommendation

- not suitable

□ uncoated grades

■ coated grades

■ brazed/Cermet

Dimensions in inch

Carbide grades

Indexable inserts can be used in right and left hand toolholders.

Indexable insert

U312

with round chip breaker

Circlip grooves
Width of groove

DIN 471/472
.062"

recommended for interrupted cut

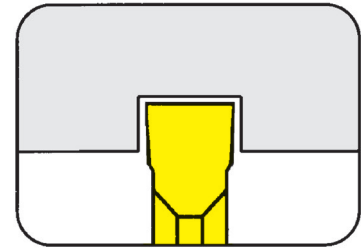

for Toolholder

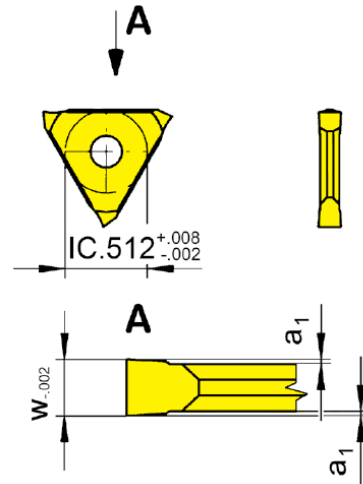

Type 309/U309
340/U340
360/U360
361
368/U368
390/U390
391
369/U369
330/U330
360C/360TS
64/65/99
N67/N68/N98

Indexability length
 $\pm .0008''$

Part number	w	a ₁	Size	TN35
U312.0062.80	.062	.008	01	▲
				P ●
				M ●
				K ●
				N ●
				S ●
				H -

▲ on stock Δ 4 weeks x upon request
● recommended
○ alternative recommendation
- not suitable
□ uncoated grades
■ coated grades
■ brazed/Cermet
Dimensions in inch

Carbide grades

Indexable inserts can be used in right and left hand toolholders.

O

Indexable insert

312

with round chip breaker

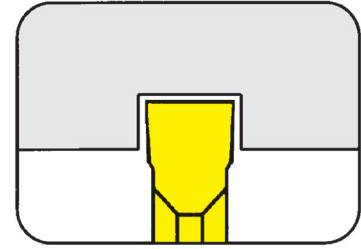

Circlip grooves
Width of circlip Nw

DIN 471/472
.043 - .203"

recommended for interrupted cut

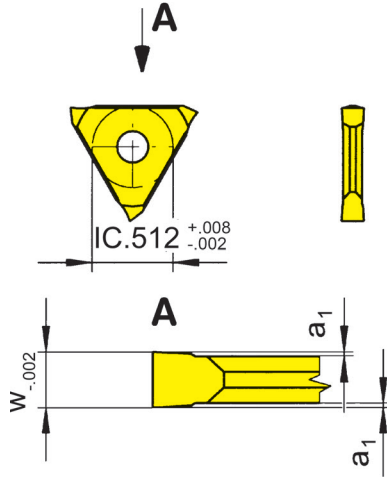

for Toolholder

- Type
- 309/U309
 - 340/U340
 - 360/U360
 - 361
 - 368/U368
 - 390/U390
 - 391
 - 369/U369
 - 330/U330
 - 360C/360TS
 - 64/65/99
 - N67/N68/N98

Indexability length
± .0008"

Part number	w	Nw	a ₁	Size	Carbide grades		
					EG55	TN35	
312.0110.80	.049	.043	.008	01	▲	▲	
312.0130.80	.057	.051	.008	01	▲	▲	
312.0160.80	.069	.063	.008	01	▲	▲	
312.0185.80	.078	.073	.008	01	▲	▲	
312.0215.80	.090	.085	.008	02	▲	▲	
312.0265.80	.110	.104	.008	02	▲	▲	
312.0315.80	.130	.124	.008	03	▲	▲	
312.0415.80	.169	.163	.008	04	▲	▲	
312.0515.80	.208	.203	.008	04	▲	▲	
					P	•	•
					M	○	•
					K	○	•
					N	-	•
					S	-	•
					H	-	-

▲ on stock Δ 4 weeks x upon request

- recommended
- alternative recommendation
- not suitable

- uncoated grades
- coated grades
- brazed/Cermet

Dimensions in inch

Carbide grades

Indexable inserts can be used in right and left hand toolholders.

Grooving (external and internal)



Indexable insert

312

with round chip breaker

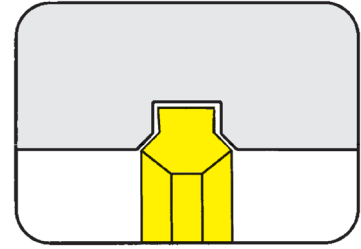

Circlip grooves
Width of circlip Nw

DIN 471/472
.043 - .203"

with chamfer

for Toolholder

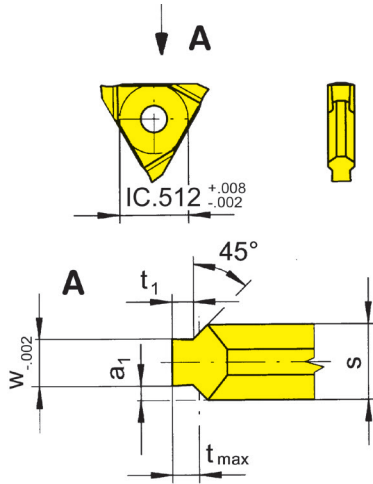

Type 309/U309
340/U340
360/U360
361
368/U368
390/U390
391
369/U369
330/U330
360C/360TS
64/65/99
N67/N68/N98

Indexability length
± .0008"

Part number	w	Nw	t _{max}	a ₁	s	t ₁	Size	P20	EG52	TN32	TN35	
312.1101.25	.049	.043	.008	.025	.098	.007	02		Δ	Δ		
312.1102.25	.049	.043	.010	.025	.098	.009	02		▲	▲		
312.1103.25	.049	.043	.012	.025	.098	.011	02		▲	▲		
312.1104.25	.049	.043	.014	.025	.098	.013	02		Δ	▲		
312.1105.25	.049	.043	.016	.025	.098	.014	02	▲	▲	▲	x	
312.1306.25	.057	.051	.022	.021	.098	.018	02	x	▲	▲		
312.1607.33	.069	.063	.028	.031	.130	.024	03		▲	▲		
312.1608.33	.069	.063	.033	.031	.130	.030	03	x	▲	▲		
312.1609.33	.069	.063	.039	.031	.130	.033	03		▲	▲		
312.1810.33	.078	.073	.039	.026	.130	.033	03		▲	▲		
312.1812.33	.078	.073	.049	.026	.130	.043	03	x	x	▲		
312.2115.43	.090	.085	.059	.040	.169	.053	04	▲	x	▲		
312.2616.43	.110	.104	.059	.030	.169	.053	04	▲	x	▲		
312.2617.43	.110	.104	.069	.030	.169	.063	04	x	x	▲		
312.3118.53	.130	.124	.069	.040	.209	.063	04	x	x	▲		
312.4120.53	.169	.163	.079	.020	.209	.073	04		x	▲		
312.4125.53	.169	.163	.098	.020	.209	.093	04		Δ	▲		
312.5130.63	.208	.203	.118	.020	.248	.112	04		Δ	▲		
								P	•	•	•	•
								M	-	o	-	•
								K	-	-	-	•
								N	-	-	-	•
								S	-	-	-	•
								H	-	-	-	-

▲ on stock Δ 4 weeks x upon request
 ● recommended
 o alternative recommendation
 - not suitable
 ■ uncoated grades
 ■ coated grades
 ■ brazed/Cermet

P	•	•	•	•
M	-	o	-	•
K	-	-	-	•
N	-	-	-	•
S	-	-	-	•
H	-	-	-	-

Dimensions in inch

Carbide grades

Indexable inserts can be used in right and left hand toolholders.

O

Indexable insert

U312

with round chip breaker

Depth of groove up to
Width of groove

.315"
.062 - .250"

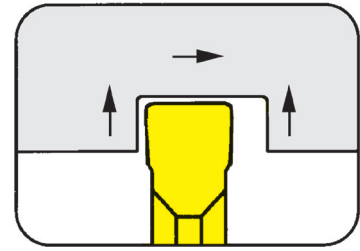

for Toolholder

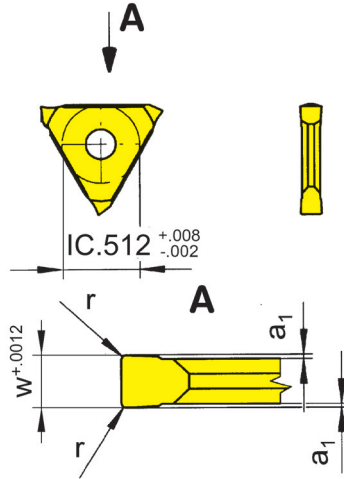

- Type
- 309/U309
 - 340/U340
 - 360/U360
 - 361
 - 368/U368
 - 390/U390
 - 391
 - 369/U369
 - 330/U330
 - 360C/360TS
 - 64/65/99
 - N67/N68/N98

Indexability length
± .0008"

Part number	w	r	a ₁	Size	Carbide grades						
					MG12	TF46	T122	T125	TN32	TN35	
U312.0062.04	.062	.004	.010	01		▲		▲		▲	
U312.0062.08	.062	.008	.010	01		▲		▲		▲	
U312.0094.08	.094	.008	.010	02	▲	▲		▲		▲	
U312.0094.16	.094	.016	.010	02		▲		▲		▲	
U312.0094.32	.094	.031	.010	02		▲		▲		▲	
U312.0125.08	.125	.008	.010	03		▲		▲		▲	
U312.0125.16	.125	.016	.010	03		▲		▲		▲	
U312.0250.08	.250	.008	.010	04		▲		▲		▲	
▲ on stock Δ 4 weeks x upon request ● recommended ○ alternative recommendation - not suitable □ uncoated grades ■ coated grades ■ brazed/Cermet					P	○	●	●	●	●	●
					M	-	○	-	●	-	●
					K	-	●	-	●	-	●
					N	-	●	-	●	-	●
					S	-	○	-	●	-	●
					H	-	-	-	-	-	-

Dimensions in inch

Indexable inserts can be used in right and left hand toolholders.

Indexable insert

312

with round chip breaker

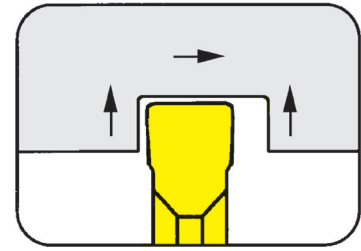

Depth of groove up to $.236''$
Width of groove $.039 - .157''$

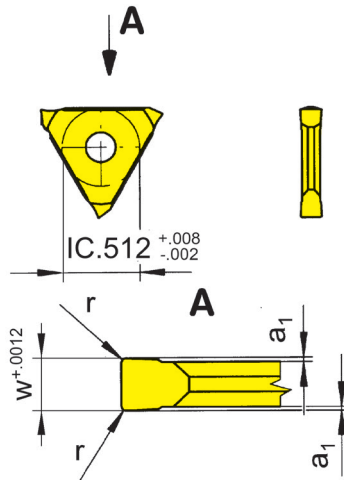

for Toolholder

- Type
- 309/U309
 - 340/U340
 - 360/U360
 - 361
 - 368/U368
 - 390/U390
 - 391
 - 369/U369
 - 330/U330
 - 360C/360TS
 - 64/65/99
 - N67/N68/N98

Indexability length
 $\pm .0008''$

Part number	w	r	a ₁	Size	K10	P20	AS62	EG52	TF45	T122	T125	TN32	TN35	TN38	H20
312.0100.02	.039	.008	.004	01				x			▲	▲			
312.0150.02	.059	.008	.010	01	x	▲		▲			▲	▲	▲		
312.0200.02	.079	.008	.010	02	▲	▲		▲		▲	▲	▲	▲		▲
312.0200.04	.079	.016	.010	02		▲	▲	▲			▲	▲	▲		▲
312.0300.02	.118	.008	.010	03	x	▲		▲			▲	▲	▲		▲
312.0300.06	.118	.024	.010	03		▲		▲			▲	▲	▲		▲
312.0300.08	.118	.031	.010	03		▲		▲			▲	▲	▲	x	▲
312.0400.02	.157	.008	.010	04		▲		▲			▲	▲	▲		▲
312.0400.08	.157	.031	.010	04		x		▲			▲	▲	▲		▲
312.0400.12	.157	.047	.010	04		Δ		Δ							
▲ on stock Δ 4 weeks x upon request					P	●	●	●	●	●	●	●	●	●	●
● recommended					M	○	-	-	○	●	-	●	●	●	○
○ alternative recommendation					K	●	-	-	-	●	-	-	●	-	-
- not suitable					N	●	-	-	-	●	-	●	-	-	-
uncoated grades					S	○	-	-	-	●	-	●	-	-	-
coated grades					H	-	-	-	-	-	-	-	-	-	-
brazed/Cermet															

Dimensions in inch

Carbide grades

Indexable inserts can be used in right and left hand toolholders.

O

Indexable insert

312

Depth of cut up to .138"

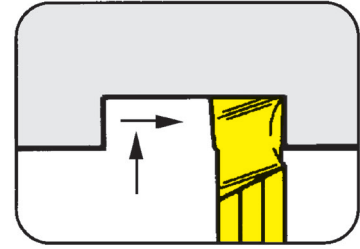

for Toolholder

- Type
- 309/U309
 - 340/U340
 - 360/U360
 - 361
 - 368/U368
 - 390/U390
 - 391
 - 369/U369
 - 330/U330
 - 360C/360TS
 - 64/65/99
 - N67/N68/N98

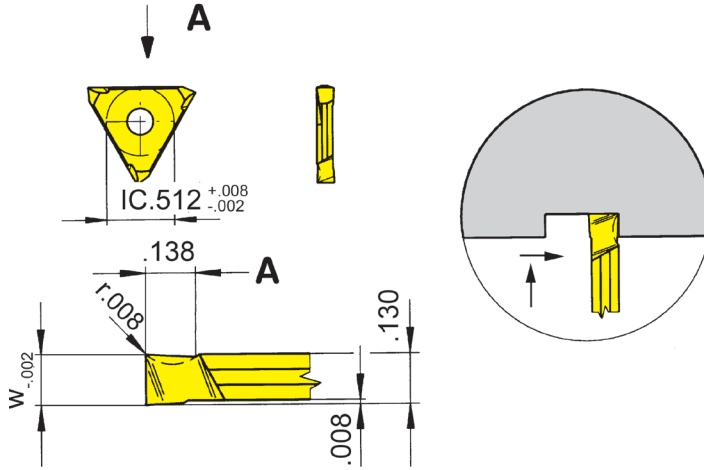

L = left hand version shown

R = right hand version

Indexability length
± .0008"

Part number	w	Size	Carbide grades			
			P20	EG52	TC92	TN32
R/L312.3031.33	.13	03	▲/▲	▲/▲	x/▲	▲/▲
▲ on stock Δ 4 weeks x upon request ● recommended ○ alternative recommendation - not suitable □ uncoated grades ■ coated grades ■ brazed/Cermet			P	●	●	●
			M	-	○	-
			K	-	-	-
			N	-	-	-
			S	-	-	-
			H	-	-	-

State R or L version

Indexable inserts can be used in right and left hand toolholders.

The special cutting geometry permits a positive chip breaking angle when keeping a straight and right angled cutting edge.

Grooving Corner Reliefs (external)



Indexable insert

312

with round chip breaker

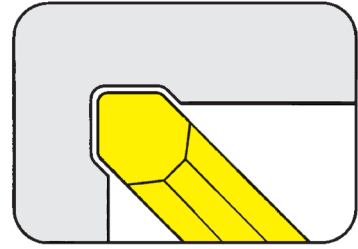

Corner reliefs similar to DIN 509 form "F"

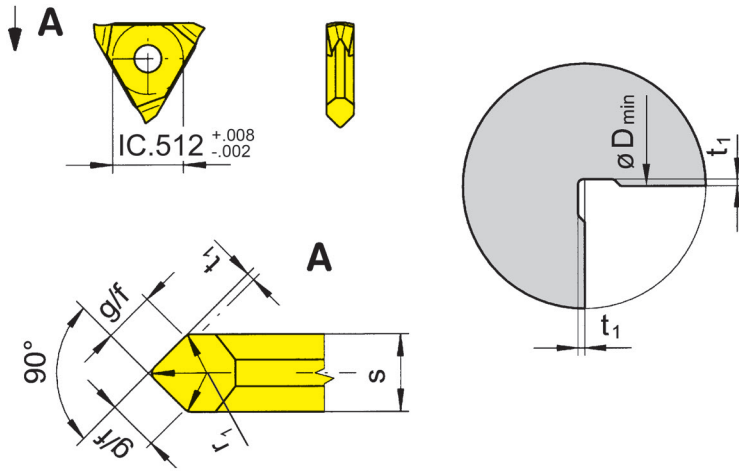

for Toolholder

- Type
- 309/U309
 - 340/U340
 - 360/U360
 - 361
 - 368/U368
 - 390/U390
 - 391
 - 369/U369
 - 330/U330
 - 360C/360TS
 - 64/65/99
 - N67/N68/N98

Indexability length
± .0008"

Part number	D _{min}	t ₁	s	g/f	r ₁	Size	Carbide grades				
							P20	AS62	EG52	TC92	
312.0602.24	.748	.008	.094	.067	.024	02	▲	▲	▲	▲	
312.0603.33	.906	.012	.130	.091	.024	03	▲		▲		
312.1002.30	.787	.008	.118	.083	.039	03	▲		△		
312.1004.50	1.142	.016	.197	.142	.039	04	▲		▲		
312.1603.50	.984	.012	.197	.142	.063	04	▲		△		
							P	●	●	●	●
							M	-	-	○	-
							K	-	-	-	-
							N	-	-	-	-
							S	-	-	-	-
							H	-	-	-	-

▲ on stock Δ 4 weeks x upon request

● recommended
○ alternative recommendation

- not suitable

uncoated grades

coated grades

brazed/Cermet

Dimensions in inch

Indexable inserts can be used in right and left hand toolholders.

Grooving Corner Reliefs (external)



O

Indexable insert

312

with round chip breaker

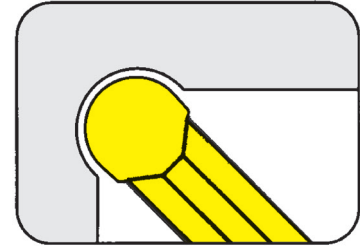

Full radius .039 - .098"

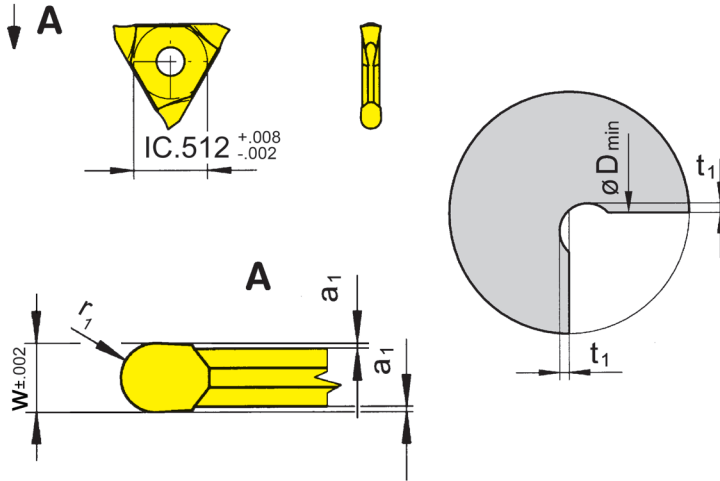

for Toolholder

- Type
- 309/U309
 - 340/U340
 - 360/U360
 - 361
 - 368/U368
 - 390/U390
 - 391
 - 369/U369
 - 330/U330
 - 360C/360TS
 - 64/65/99
 - N67/N68/N98

Indexability length
± .0008"

Part number	w	a ₁	r ₁	D _{min}	t ₁	Size	Carbide grades						
							K10	P20	EG52	TC92	TF45	TN32	TN35
312.0010.20	.079	.008	.039	.866	.028	02	▲	▲	▲	▲	x	▲	▲
312.0015.30	.118	.008	.059	1.063	.039	02	▲	▲	▲	▲		▲	▲
312.0020.40	.157	.008	.079	1.181	.047	04	▲	▲	▲	▲		▲	▲
312.0025.50	.197	.008	.098	1.378	.059	04	x	▲	▲	▲		▲	▲
P	●	●	●	●	●	●	●	●	●	●	●	●	●
M	○	-	○	-	●	-	●	-	●	-	●	●	●
K	●	-	-	-	●	-	●	-	●	-	●	●	●
N	●	-	-	-	●	-	●	-	●	-	●	●	●
S	○	-	-	-	●	-	●	-	●	-	●	●	●
H	-	-	-	-	-	-	-	-	-	-	-	-	-

▲ on stock Δ 4 weeks x upon request
 ● recommended
 ○ alternative recommendation
 - not suitable
 □ uncoated grades
 ■ coated grades
 ■ brazed/Cermet
 Dimensions in inch

Carbide grades

Indexable inserts can be used in right and left hand toolholders.

Grooving Corner Reliefs (external)



Indexable insert

U312

with round chip breaker

Depth of groove up to
Full radius

.236"
.031 - .062"

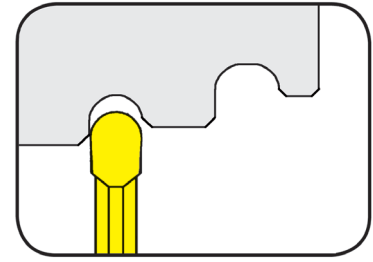

for Toolholder

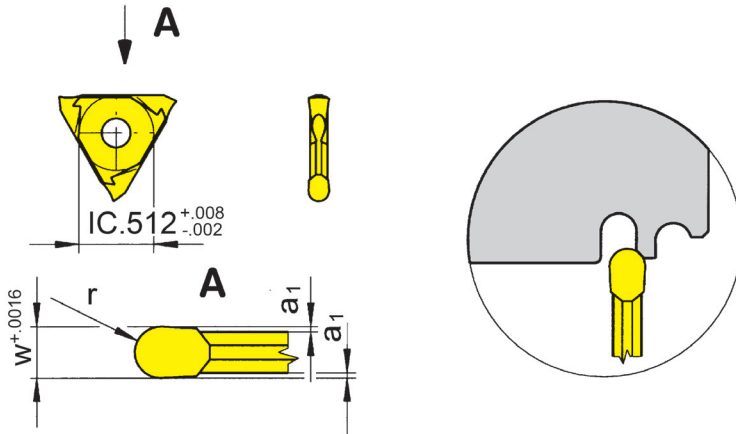

Type 309/U309
340/U340
360/U360
361
368/U368
390/U390
391
369/U369
330/U330
360C/360TS
64/65/99
N67/N68/N98

Indexability length
± .0008"

Part number	w	a ₁	r	Size	Carbide grades		
					TF46	TI22	TN32
U312.0031.62	.062	.010	.031	01	▲	▲	▲
U312.0039.78	.078	.010	.039	02	▲	▲	▲
U312.0047.94	.094	.010	.047	02	▲	▲	▲
U312.0062.12	.125	.010	.063	03	▲	▲	▲
					P	•	•
					M	○	-
					K	•	-
					N	•	-
					S	○	-
					H	-	-

▲ on stock Δ 4 weeks x upon request

● recommended
○ alternative recommendation
- not suitable

□ uncoated grades
■ coated grades
■ brazed/Cermet

Dimensions in inch

Width of groove .062" recommended only for grooving

Note:

Indexable inserts can be used in **right and left** hand toolholders.

Grooving and Profiling (Full radius)



O

Indexable insert

312

with round chip breaker

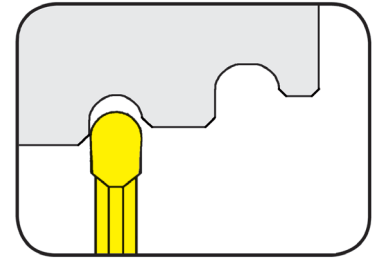

Depth of groove up to $.236''$
Full radius $.010 - .079''$

for Toolholder

- Type
- 309/U309
 - 340/U340
 - 360/U360
 - 361
 - 368/U368
 - 390/U390
 - 391
 - 369/U369
 - 330/U330
 - 360C/360TS
 - 64/65/99
 - N67/N68/N98

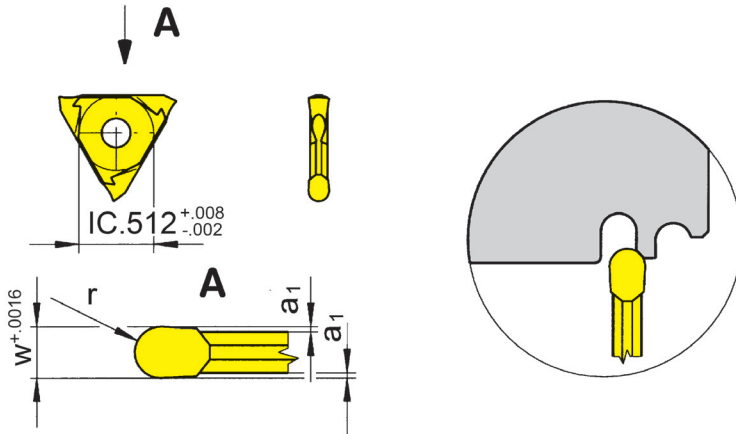

Indexability length
 $\pm .0008''$

Part number	w	a ₁	r	Size	Carbide grades								
					P20	AS45	EG35	EG55	TF45	TH35	TI25	TN32	TN35
312.0050.02	.020	.003	.010	01	▲	▲	▲					▲	
312.0100.05	.039	.004	.020	01	▲	▲	▲			x		▲	x
312.0110.05	.043	.004	.022	01		▲		Δ					
312.0120.06	.047	.008	.024	01	▲	▲		▲				▲	
312.0140.07	.055	.008	.028	01		▲		▲					
312.0160.08	.063	.010	.031	01	▲	▲		▲				▲	
312.0180.09	.071	.010	.035	01		▲		▲					
312.0200.10	.079	.010	.039	01	▲	▲		▲	x		x	▲	
312.0220.11	.087	.010	.043	02		▲		▲					
312.0250.12	.098	.010	.049	02	▲	▲		Δ				▲	
312.0280.14	.110	.010	.055	02		▲		Δ					
312.0300.15	.118	.010	.059	02	▲	▲		▲				▲	
312.0360.18	.142	.010	.071	03		▲		Δ					
312.0400.20	.157	.010	.079	03	▲	▲		Δ				▲	
					P	•	•	•	•	•	•	•	•
					M	-	•	•	o	•	•	-	•
					K	-	•	o	o	•	•	-	•
					N	-	o	-	-	•	•	-	•
					S	-	•	-	-	•	•	-	•
					H	-	-	-	-	-	-	-	-

▲ on stock Δ 4 weeks x upon request
 ● recommended
 o alternative recommendation
 - not suitable
 ■ uncoated grades
 ■ coated grades
 ■ brazed/Cermet

Further radii upon request

Dimensions in inch

Carbide grades

Note:

Width of groove up to $.063''$ recommended only for grooving

Indexable inserts can be used in right and left hand toolholders.

Grooving (external)



Indexable insert

312

with round chip breaker

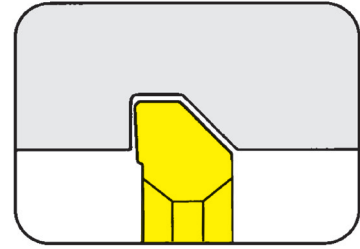

Thread relief DIN 76 "Short form"

for Toolholder

- Type
- 309/U309
 - 340/U340
 - 360/U360
 - 361
 - 368/U368
 - 390/U390
 - 391
 - 369/U369
 - 330/U330
 - 360C/360TS
 - 64/65/99
 - N67/N68/N98

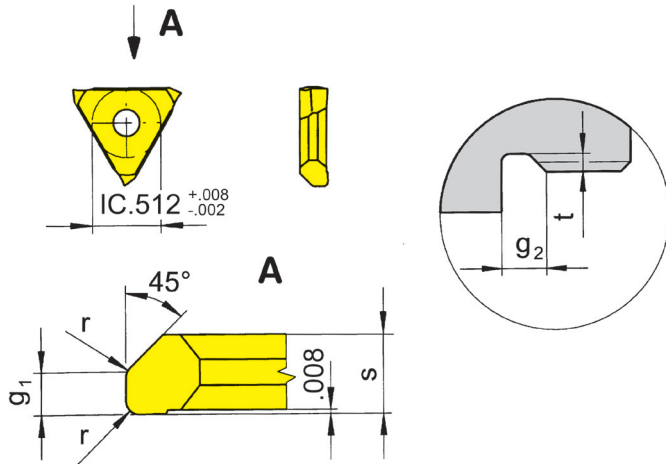

R = right hand version shown

L = left hand version

Indexability length
± .0008"

Part number	P	r	t ₁	s	g ₁	g ₂	Size	P20	EG55	TN35
R/L312.1050.17	.020	.008	.016	.067	.024	.039	01	x/x	▲/Δ	▲/x
R/L312.1060.17	.024	.016	.020	.067	.028	.047	01	x/x	Δ/Δ	x/x
R/L312.1070.17	.028	.016	.022	.067	.033	.055	01	x/x	Δ/Δ	x/x
R/L312.1080.27	.031	.016	.026	.106	.037	.063	02	x/x	▲/Δ	▲/▲
R/L312.1100.27	.039	.024	.031	.106	.047	.079	02	▲/x	▲/Δ	▲/x
R/L312.1125.27	.049	.024	.039	.106	.059	.098	02	x/x	▲/Δ	▲/▲
R/L312.1150.37	.059	.031	.045	.146	.073	.118	03	x/x	▲/Δ	▲/▲
R/L312.1175.37	.069	.039	.051	.146	.087	.138	03	x/x	Δ/Δ	x/x
R/L312.1200.53	.079	.039	.059	.209	.098	.157	04	▲/▲	Δ/Δ	x/x
R/L312.1250.53	.098	.047	.071	.209	.126	.197	04	x/x	Δ/Δ	x/x
R/L312.1300.63	.118	.063	.087	.248	.150	.236	04	x/x	Δ/Δ	x/x

▲ on stock Δ 4 weeks x upon request
● recommended
○ alternative recommendation
- not suitable

- uncoated grades
- coated grades
- brazed/Cermet

Dimensions in inch

State R or L version

Use right hand inserts in right hand toolholders and left hand inserts in left hand toolholders

	P	EG55	TN35
P	●	●	●
M	-	○	●
K	-	○	●
N	-	-	●
S	-	-	●
H	-	-	-

Carbide grades

Grooving (external)



O

Indexable insert

312

with round chip breaker

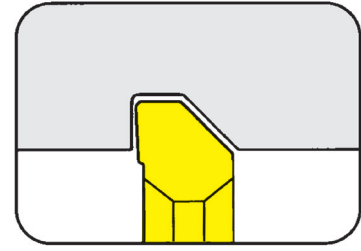

Thread relief DIN 76 "Standard form"

for Toolholder

- Type
- 309/U309
 - 340/U340
 - 360/U360
 - 361
 - 368/U368
 - 390/U390
 - 391
 - 369/U369
 - 330/U330
 - 360C/360TS
 - 64/65/99
 - N67/N68/N98

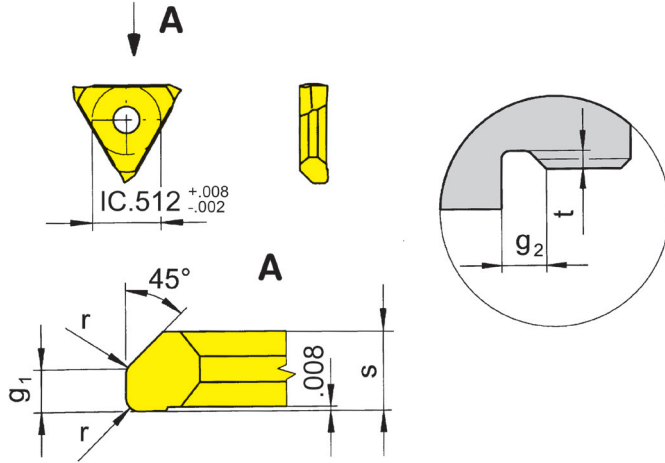

R = right hand version shown

L = left hand version

Indexability length
± .0008"

Part number	P	r	t ₁	s	g ₁	g ₂	Size	P20	EG55	TN35	
R/L312.3050.17	.020	.008	.016	.067	.043	.059	01	x/x	Δ/Δ	x/▲	
R/L312.3060.27	.024	.016	.020	.106	.051	.071	02	x/x	▲/▲	▲/x	
R/L312.3070.27	.028	.016	.022	.106	.061	.083	02	x/x	Δ/Δ	x/x	
R/L312.3080.27	.031	.016	.026	.106	.069	.094	02	x/x	Δ/Δ	x/x	
R/L312.3100.37	.039	.024	.031	.146	.087	.118	03	x/x	▲/Δ	▲/x	
R/L312.3125.53	.049	.024	.039	.209	.110	.150	04	x/x	Δ/Δ	Δ/x	
R/L312.3150.53	.059	.031	.045	.209	.132	.177	04	x/x	▲/Δ	▲/x	
R/L312.3175.56	.069	.039	.051	.220	.157	.209	04	x/x	Δ/Δ	Δ/x	
R/L312.3200.63	.079	.039	.059	.248	.177	.236	04	x/x	Δ/Δ	Δ/x	
	▲	●	○	■	■	■		P	•	•	•
		●	○	■	■	■		M	-	o	•
		●	○	■	■	■		K	-	o	•
		●	○	■	■	■		N	-	-	•
		●	○	■	■	■		S	-	-	•
		●	○	■	■	■		H	-	-	-

▲ on stock Δ 4 weeks x upon request

- recommended
- alternative recommendation
- not suitable

- uncoated grades
- coated grades
- brazed/Cermet

Dimensions in inch

State R or L version

Use right hand inserts in right hand toolholders and left hand inserts in left hand toolholders

Carbide grades

Grooving (external)



Indexable insert

312

Poly-V-belt grooves profile "J"

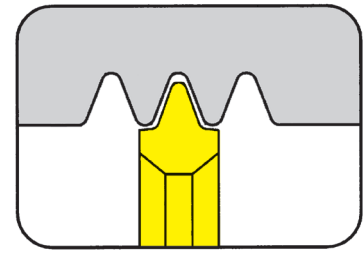

for Toolholder

- Type
- 309/U309
 - 340/U340
 - 360/U360
 - 361
 - 368/U368
 - 390/U390
 - 391
 - 369/U369
 - 330/U330
 - 360C/360TS
 - 64/65/99
 - N67/N68/N98

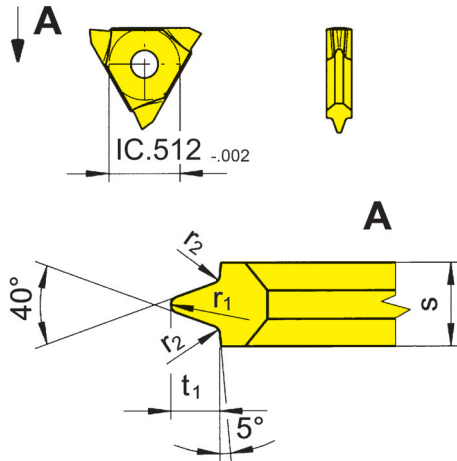

Indexability length
± .0008"

Part number	r ₂	t ₁	s	r ₁	Size	Carbide grades		
						P20	EG52	TN32
312.0223.23	.008	.091	.092	.01	02	x	▲	x
312.0223.30	.008	.091	.118	.01	03	▲	▲	▲
						P	•	•
						M	-	o
						K	-	-
						N	-	-
						S	-	-
						H	-	-

▲ on stock Δ 4 weeks x upon request

- recommended
- o alternative recommendation
- not suitable

uncoated grades
coated grades
brazed/Cermet

Dimensions in inch

Insert 312.0223.23 for multi grooving Insert 312.0223.30 for single grooving

Indexable inserts can be used in right and left hand toolholders.

Shape of groove:

Poly-V-belt grooves profile „J”

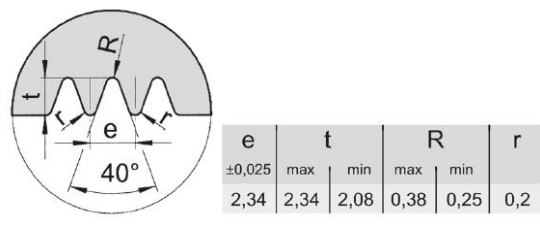



Indexable insert

312

with round chip breaker

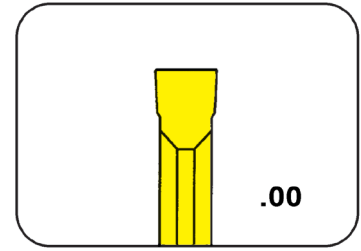

Depth of groove up to
Width of groove

.197"
.057"

for Toolholder

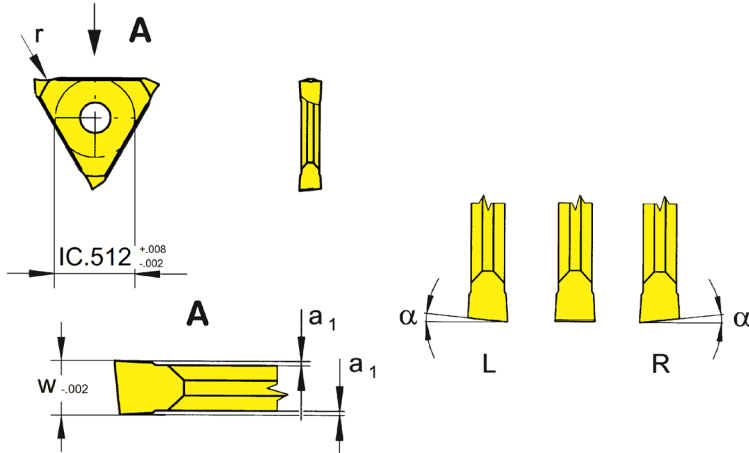

- Type
- 309/U309
 - 340/U340
 - 360/U360
 - 361
 - 368/U368
 - 390/U390
 - 391
 - 369/U369
 - 330/U330
 - 360C/360TS
 - 64/65/99
 - N67/N68/N98

R = right hand version shown

L = left hand version

Part number	w	α	a ₁	Size	Carbide grades				
					EG35	TF45	TF46	TI25	TN35
R/L312.0614.00	.057	6°	.008	01	▲/▲	▲/▲	▲/x	▲/▲	▲/▲
					P	•	•	•	•
					M	•	○	•	•
					K	○	•	•	•
					N	-	•	•	•
					S	-	•	○	•
					H	-	-	-	-

▲ on stock Δ 4 weeks x upon request
 ● recommended
 ○ alternative recommendation
 - not suitable
 ■ uncoated grades
 ■ coated grades
 ■ brazed/Cermet
 Dimensions in inch State R or L version

External machining:

for Toolholder type 360 use right hand inserts in left hand toolholders and left hand inserts in right hand toolholders

Parting off solid bars

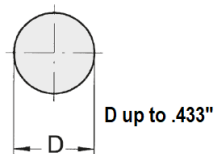

Parting off tubes

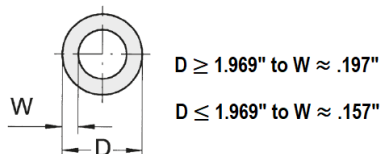

Indexable insert

312

with round chip breaker

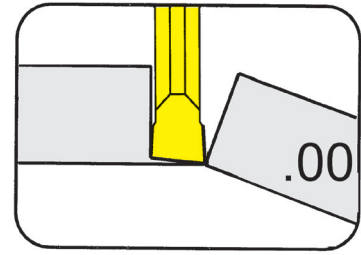

Depth of groove up to .315"
Width of groove .020 - .059"

for Toolholder

- Type
- 309/U309
 - 340/U340
 - 360/U360
 - 361
 - 368/U368
 - 390/U390
 - 391
 - 369/U369
 - 330/U330
 - 360C/360TS
 - 64/65/99
 - N67/N68/N98

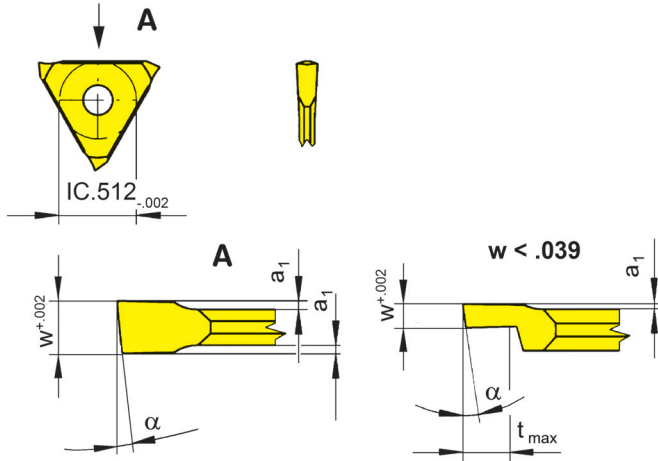

R = right hand version shown

L = left hand version

Part number	w	t _{max}	α	a ₁	Size	K10	P20	EG35	EG55	TC92	TF45	TF46	TI25	TN32	TN35	H20
R/L312.0805.00	.020	.039	8°	.004	01			▲/▲			▲/▲					
R/L312.0808.00	.031	.059	8°	.004	01			▲/▲			▲/▲					
R/L312.0510.00	.039	.315	5°	.004	01			▲/▲			▲/▲					
R/L312.1210.00	.039	.315	12°	.004	01			▲/▲			▲/▲		x/x		▲/▲	
R/L312.0512.00	.047	.315	5°	.008	01			▲/▲			▲/▲					
R/L/312.0515.00	.059	.315	5°	.008	01	▲/x	▲/x	▲/▲	▲/x	x/x	▲/▲/▲	▲/x		▲/x		▲/x

▲ on stock Δ 4 weeks x upon request

● recommended

○ alternative recommendation

- not suitable

□ uncoated grades

■ coated grades

■ brazed/Cermet

	P	M	K	N	S	H
P	●	●	●	●	●	●
M	○	-	○	-	○	○
K	●	-	○	-	○	-
N	●	-	-	-	●	-
S	○	-	-	-	○	-
H	-	-	-	-	-	-

Dimensions in inch

Carbide grades

State R or L version

O

Indexable insert

312

Depth of groove up to $.315''$
 Width of groove $.047 - .059''$

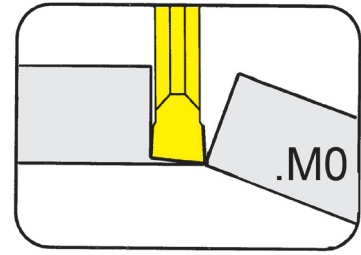

for Toolholder

- Type
- 309/U309
 - 340/U340
 - 360/U360
 - 361
 - 368/U368
 - 390/U390
 - 391
 - 369/U369
 - 330/U330
 - 360C/360TS
 - 64/65/99
 - N67/N68/N98

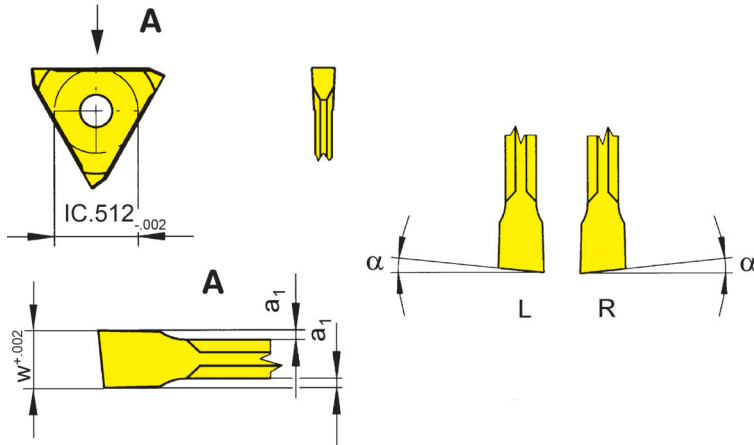

R = right hand version shown

L = left hand version

Part number	w	t _{max}	α	a ₁	Size	Carbide grades		
						K10	EG35	TF45
R/L312.0512.M0	.047	.315	5°	.008	01	x/Δ	▲/▲	▲/Δ
R/L312.0515.M0	.059	.315	5°	.008	01	▲/x	▲/▲	▲/Δ
						P	•	•
						M	○	•
						K	•	○
						N	•	-
						S	○	-
						H	-	-

▲ on stock Δ 4 weeks x upon request

- recommended
- alternative recommendation
- not suitable

- uncoated grades
- coated grades
- brazed/Cermet

Dimensions in inch

State R or L version

Grooving and Parting Off



Indexable insert

312

with round chip breaker

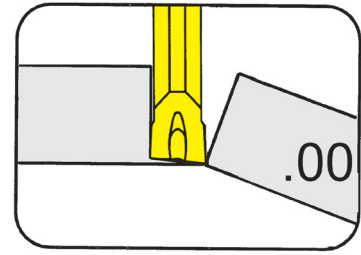

Depth of groove up to .197"
Width of groove .057 - .090"

for Toolholder

- Type
- 309/U309
 - 340/U340
 - 360/U360
 - 361
 - 368/U368
 - 390/U390
 - 391
 - 369/U369
 - 330/U330
 - 360C/360TS
 - 64/65/99
 - N67/N68/N98

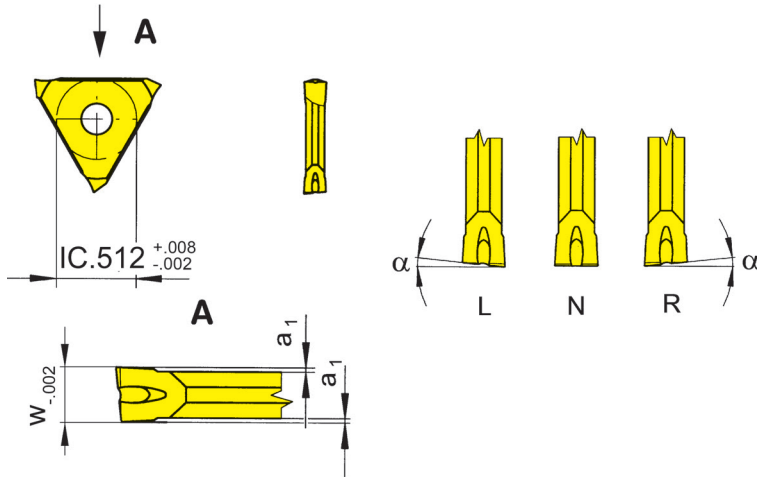

R = right hand version shown

L = left hand version

Part number	w	α	a ₁	Size	Carbide grades						
					MG12	P20	EG55	TC92	TF45	TN32	TN35
N312.0014.00	.057	0°	.008	02			▲	x	▲		
N312.0018.00	.078	0°	.008	02			▲	▲	▲	x	x
N312.0021.00	.090	0°	.008	02		x	▲	x			▲
R/L312.0514.00	.057	5°	.008	02		x/x	Δ/Δ		x/x		
R/L312.0518.00	.078	5°	.008	02		▲/▲	▲/▲	x/x		▲/▲	▲/▲
R/L312.0521.00	.090	5°	.008	02		x/x	▲/▲	x/x		▲/▲	▲/▲
					P	●	●	●	●	●	●
					M	-	-	○	-	-	●
					K	-	-	○	-	-	●
					N	-	-	-	-	●	●
					S	-	-	-	-	●	●
					H	-	-	-	-	-	-

▲ on stock Δ 4 weeks x upon request
● recommended
○ alternative recommendation
- not suitable

uncoated grades
coated grades
brazed/Cermet

Dimensions in inch

Carbide grades

State R or L version
External machining:

for Toolholder type 360 use right hand inserts in left hand toolholders and left hand inserts in right hand toolholders

Parting off solid bars

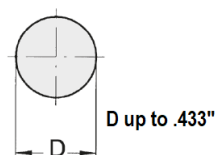

Parting off tubes

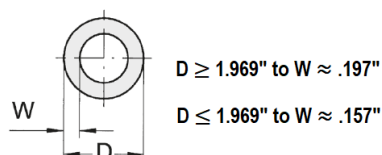

O

Indexable insert

U312

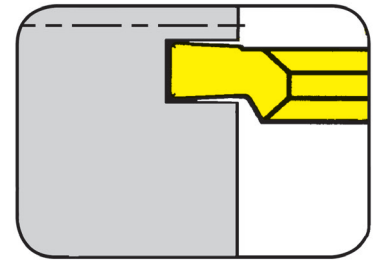

from outer groove \varnothing	.787"
Depth of groove up to	.118"
Width of groove	.062 - .125"

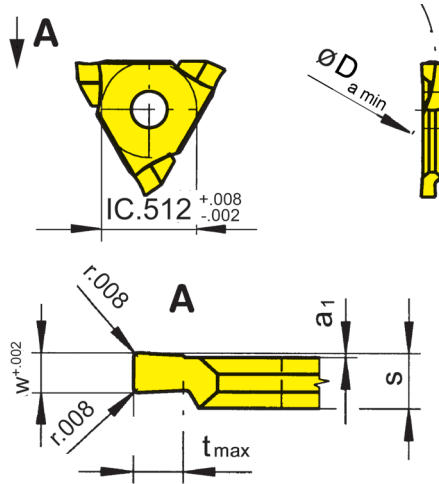

for Toolholder

- Type
- 309/U309
 - 340/U340
 - 360/U360
 - 361
 - 368/U368
 - 390/U390
 - 391
 - 369/U369
 - 330/U330
 - 360C/360TS
 - 64/65/99
 - N67/N68/N98

Indexability length
± .0008"

R = right hand version shown

L = left hand version

Part number	w	t _{max}	Da _{min}	a ₁	s	Size	TN35
R/LU312.2062.08	.062	.079	.787	.008	.106	02	▲/▲
R/LU312.3094.08	.094	.118	1.181	.008	.146	03	▲/▲
R/LU312.3125.08	.125	.118	1.181	.008	.146	03	▲/▲

▲ on stock Δ 4 weeks x upon request

- recommended
- alternative recommendation
- not suitable

- uncoated grades
- coated grades
- brazed/Cermet

Dimensions in inch

P	•
M	•
K	•
N	•
S	•
H	-

Carbide grades

State R or L version

Note for toolholder type 360

Use right hand inserts in left hand toolholders and left hand inserts in right hand toolholders

Note for toolholder type 369

Use right hand inserts in right hand toolholders and left hand inserts in left hand toolholders

Face Grooving



Indexable insert

312

from outer groove \emptyset	.787"
Depth of groove up to	.138"
Width of groove	.059 - .197"

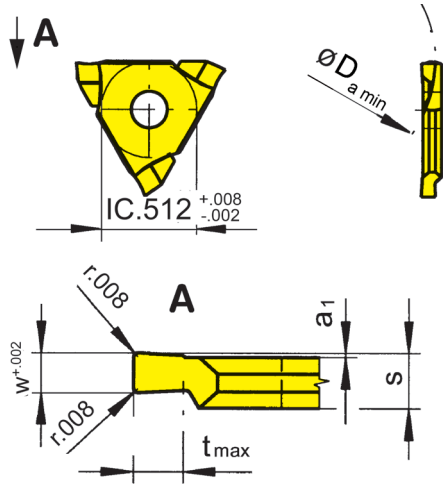
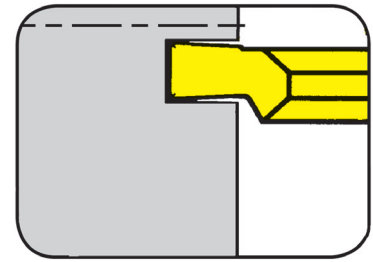

for Toolholder

- Type
- 309/U309
 - 340/U340
 - 360/U360
 - 361
 - 368/U368
 - 390/U390
 - 391
 - 369/U369
 - 330/U330
 - 360C/360TS
 - 64/65/99
 - N67/N68/N98

Indexability length \pm .0006"

R = right hand version shown

L = left hand version

Part number	w	t _{max}	a ₁	s	D _{a min}	Size	MG12	EG55	TN35
R/L312.2015.02	.059	.079	.008	.106	.787	02		▲/▲	▲/▲
R/L312.3020.02	.079	.118	.008	.106	1.181	02	x/x	▲/▲	▲/▲
R/L312.3030.02	.118	.118	.008	.146	1.181	03		▲/▲	▲/▲
R/L312.3040.02	.157	.138	.008	.169	1.181	04		Δ/Δ	
R/L312.3050.02	.197	.138	.008	.209	1.181	05		Δ/Δ	

▲ on stock Δ 4 weeks x upon request

● recommended

o alternative recommendation

- not suitable

□ uncoated grades

■ coated grades

■ brazed/Cermet

Dimensions in inch

	P	M	K	N	S	H
MG12	o	-	-	-	-	-
EG55	•	o	o	-	-	-
TN35	•	•	•	•	•	-

Carbide grades

State R or L version

Note for toolholder type 360

Use right hand inserts in left hand toolholders and left hand inserts in right hand toolholders

Note for toolholder type 369

Use right hand inserts in right hand toolholders and left hand inserts in left hand toolholders



315

P



Toolholder with Inserts

Width of groove .197 - .315"

P

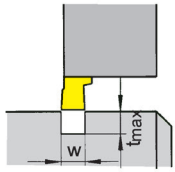

$w = .02 - .295"$
(0.5 - 7.5 mm)
 $t_{max} = .197"$ (5 mm)

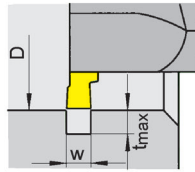

$w = .02 - .138"$
(0.5 - 3.5 mm)
 $t_{max} = .197"$ (5 mm)
 $D \geq 1.693"$ (43 mm)

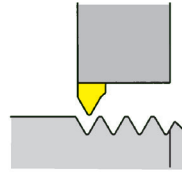

Metric trapezoidal thread
External

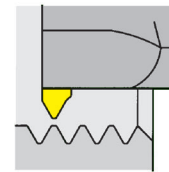

Metric trapezoidal thread
Internal

Toolholder
356

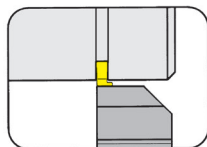

Page
P3-P7, P10

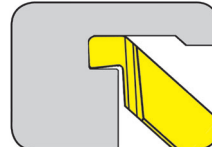

Page
P20

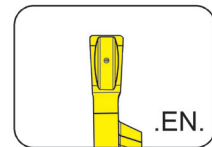

Page
P30

Toolholder
357

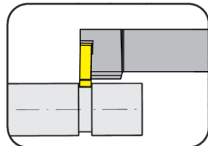

Page
P8-P9

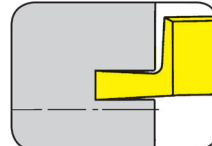

Page
P21-P22

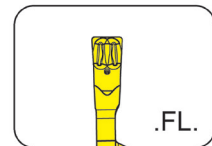

Page
P31

Toolholder
356

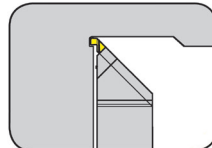

Page
P11

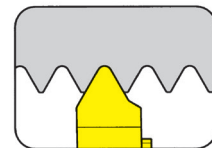

Page
P23

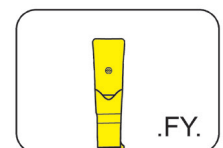

Page
P32

Toolholder
333

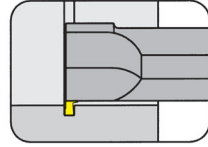

Page
P12-P13

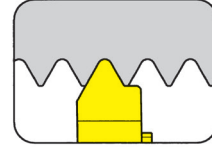

Page
P24, P27

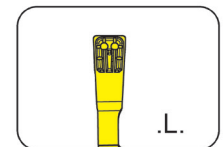

Page
P33

Cartridge
357

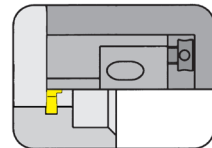

Page
P14-P15

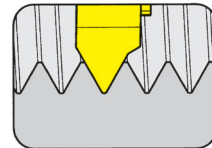

Page
P25

Indexable Insert
315/A315/S315

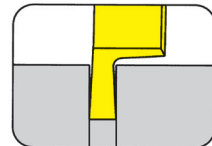

Page
P16-P18

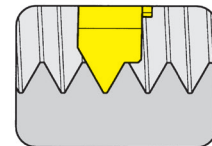

Page
P26

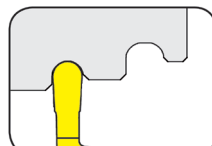

Page
P19

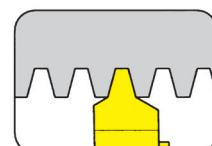

Page
P28

Grooving and Threading (external)



Toolholder

U356

Depth of groove up to	.236"
Width of groove	.209"

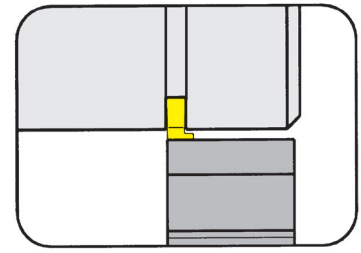

for Indexable insert

Type 315
A315

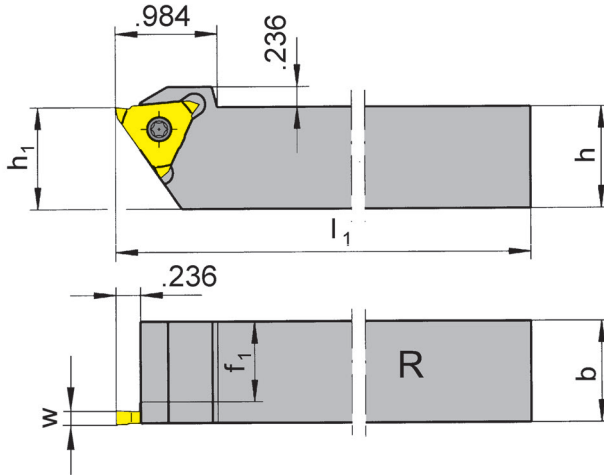

R = right hand version shown

L = left hand version

Part number	h	b	l ₁	h ₁	f ₁	Size
R/LU356.0750.05	.750	.750	5.118	.750	.545	05
R/LU356.1000.05	1.000	1.000	6.004	1.000	.795	05
R/LU356.1250.05	1.250	1.250	6.693	1.250	1.045	05

State R or L version

w see indexable inserts

Dimensions in inch

Further sizes upon request

For torque specification of the screw, please see Technical Instructions.

Spare Parts

Toolholder	Clamping Screw	TORX PLUS® Wrench
R/LU356...	5.12T20P	T20PQ

Grooving and Threading (external)



Toolholder

356

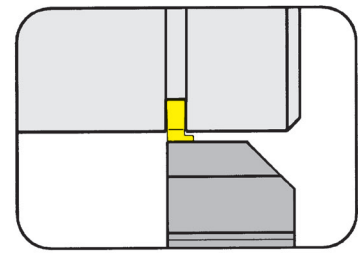

Depth of groove up to 5 mm
Width of groove 0.5 - 7.3 mm

for Indexable insert

Type 315
LA315
RA315

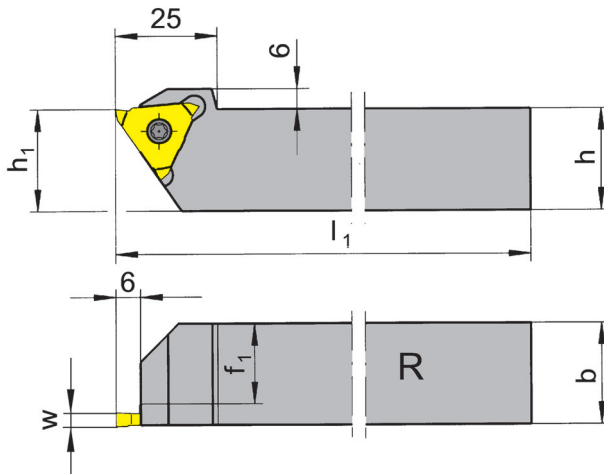

R = right hand version shown

L = left hand version

Part number	h	b	l ₁	h ₁	f ₁	Size
R/L356.1616.03	16	16	125	20	13.0	03
R/L356.2020.03	20	20	125	20	17.0	03
R/L356.2525.03	25	25	150	25	22.0	03
R/L356.3232.03	32	32	170	32	29.0	03
R/L356.1616.05	16	16	125	20	10.8	05
R/L356.2020.05	20	20	125	20	14.8	05
R/L356.2525.05	25	25	150	25	19.8	05
R/L356.3232.05	32	32	170	32	26.8	05
R/L356.2020.07	20	20	125	20	13.0	07
R/L356.2525.07	25	25	150	25	18.0	07
R/L356.3232.07	32	32	170	32	25.0	07

State R or L version

w see indexable inserts

Dimensions in mm

Further sizes upon request

For torque specification of the screw, please see Technical Instructions.

Spare Parts

Toolholder	Clamping Screw	TORX PLUS® Wrench
R/L356...	5.12T20P	T20PQ
R/L356...07	5.15T20P	T20PQ

Toolholder

356

Depth of groove up to
Width of groove

5 mm
0.5 - 5.3 mm

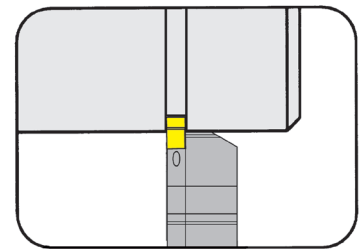

P

for Indexable insert

Type 315
LA315
RA315

Depth of groove in relation to outer- \emptyset

D_{max}	t_{max}
30	5,0
40	4,5
60	4,0
115	3,5
185	3,0

with integrated through
coolant supply

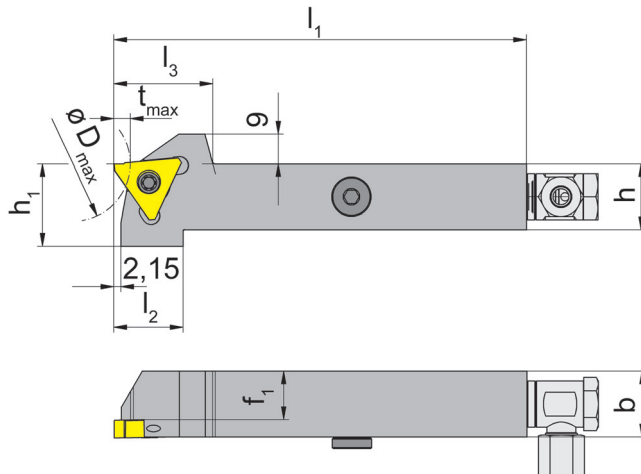

R = right hand version shown

L = left hand version

Part number	h	b	l_1	l_2	l_3	h_1	f_1	Size
R/L356.1616.0.13.IK	16	16	125	22	28	21	13.0	03
R/L356.2020.0.13.IK	20	20	125	21	30	25	17.0	03
R/L356.2525.0.13.IK	25	25	150	21	30	30	22.0	03
R/L356.1616.0.15.IK	16	16	125	22	28	21	10.8	05
R/L356.2020.0.15.IK	20	20	125	21	30	25	14.8	05
R/L356.2525.0.15.IK	25	25	150	21	30	30	19.8	05

State R or L version

Dimensions in mm

Further sizes upon request

For torque specification of the screw, please see Technical Instructions.

Spare Parts

Toolholder	Clamping Screw	Sealing plug	Threaded Pin	Coolant supply	TORX PLUS® Wrench
R/L356...	5.12T20P	004.00.26	18.05.913	004.00.16	T20PQ

Grooving and Threading (external)



Toolholder

356

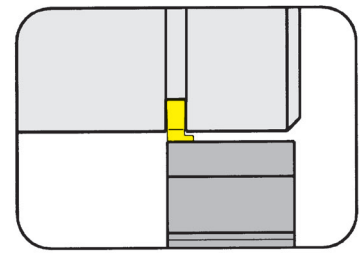

for Indexable insert

Type 315
LA315
RA315

Depth of groove in relation to outer- \emptyset

D_{max}	t_{max}
30	5,0
40	4,5
60	4,0
115	3,5
185	3,0

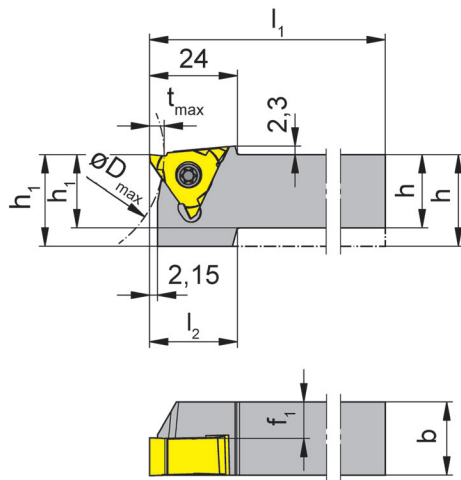

R = right hand version shown

L = left hand version

Part number	h	b	l_1	l_2	h_1	f_1	Size
R/L356.1616.13	16	16	125	21	20	13.0	03
R/L356.2020.13	20	20	125	-	20	17.1	03
R/L356.2525.13	25	25	150	-	25	22.1	03
R/L356.1616.15	16	16	125	21	20	10.8	05
R/L356.2020.15	20	20	125	21	20	14.8	05
R/L356.2525.15	25	25	150	-	25	19.8	05
R/L356.1616.16	16	16	125	-	20	10.0	06
R/L356.2020.16	20	20	125	21	25	14.0	06
R/L356.2525.16	25	25	150	-	25	19.0	06
R/L356.2020.17	20	20	125	21	25	13.0	07
R/L356.2525.17	25	25	150	-	25	18.1	07

State R or L version

Dimensions in mm

Further sizes upon request

For torque specification of the screw, please see Technical Instructions.

Spare Parts

Toolholder	Clamping Screw	TORX PLUS® Wrench
R/L356...	5.12T20P	T20PQ
R/L356...17	5.15T20P	T20PQ

Toolholder

356

Depth of groove up to
Width of groove

5 mm
10.3 - 13.3 mm

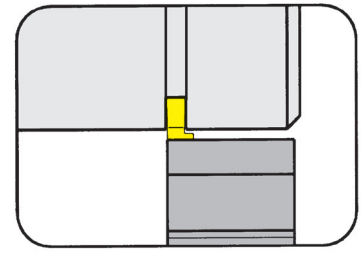

for Indexable insert

Type 315

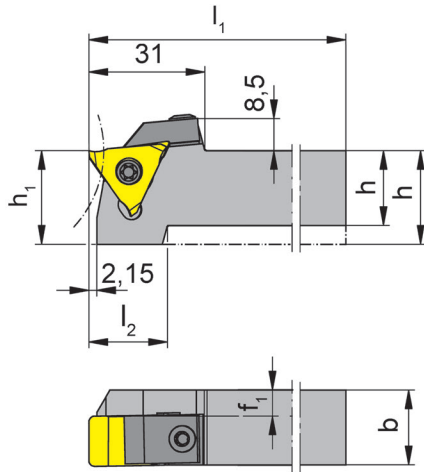

R = right hand version shown

L = left hand version

Depth of groove in relation to outer-Ø

D _{max}	t _{max}
30	5,0
40	4,5
60	4,0
115	3,5
185	3,0

Part number	h	b	l ₁	l ₂	h ₁	f ₁	Size
R/L356.2020.2.13	20	20	125	21	25	7	13
R/L356.2525.2.13	25	25	150	-	25	12	13

State R or L version

Dimensions in mm

Further sizes upon request

For torque specification of the screw, please see Technical Instructions.

Spare Parts

Toolholder	Clamping Screw	Clamping element	TORX PLUS® Wrench
R/L356...	5.12T20P	010.2013.0468	T20PQ

Toolholder

357

Depth of groove up to
Width of groove

5 mm
0.5 - 5.3 mm

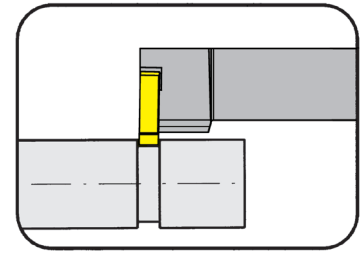

for Indexable insert

Type 315

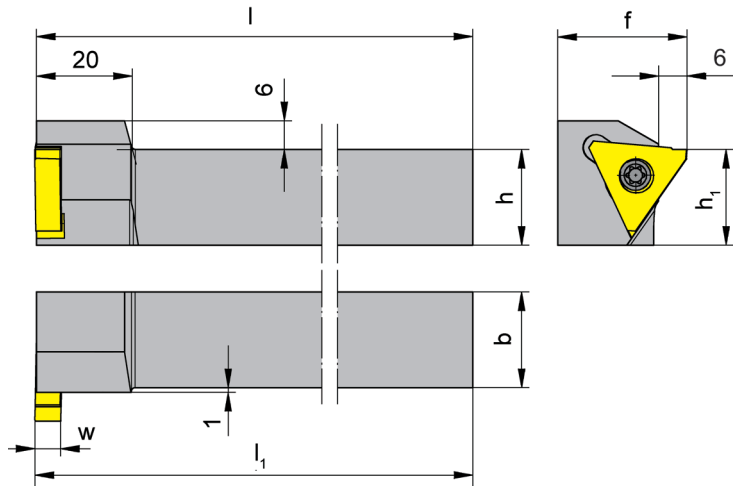

R = right hand version shown

L = left hand version

Part number	h	b	l ₁	l	h ₁	f	Size
R/L357.2020.05	20	20	125.3	125	20	27	05
R/L357.2525.05	25	25	150.3	150	25	32	05

State R or L version

w see indexable inserts

Dimensions in mm

Further sizes upon request

Ordering note:

Use right hand inserts in left hand toolholders and left hand inserts in right hand toolholders

For torque specification of the screw, please see Technical Instructions.

Spare Parts

Toolholder	Clamping Screw	TORX PLUS® Wrench
R/L357...	5.12T20P	T20PQ

Toolholder

357

Depth of groove up to
Width of groove

5 mm
0.5 - 5.3 mm

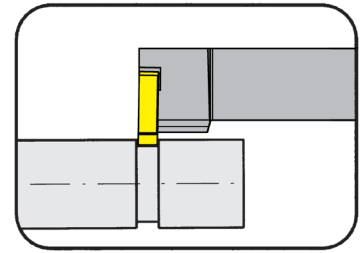

P

for Indexable insert

Type 315
A315

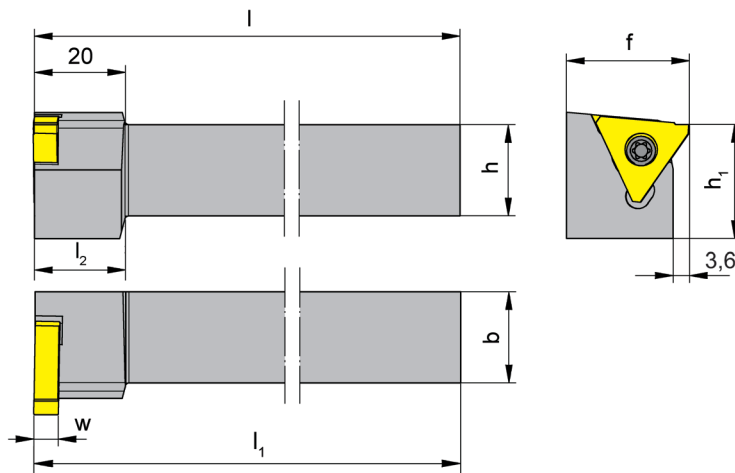

R = right hand version shown

L = left hand version

Part number	h	b	l_1	l	l_2	h_1	f	Size
R/L357.2020.15	20	20	125.3	125	20	25	27	05
R/L357.2525.15	25	25	150.3	150	-	25	32	05

State R or L version

w see indexable inserts

Dimensions in mm

Further sizes upon request

Ordering note:

Use right hand inserts in left hand toolholders and left hand inserts in right hand toolholders

For torque specification of the screw, please see Technical Instructions.

Spare Parts

Toolholder	Clamping Screw	TORX PLUS® Wrench
R/L357...	5.12T20P	T20PQ

Grooving (external)



Toolholder

356

Depth of groove up to
Width of groove

6 mm
1.1 - 2 mm

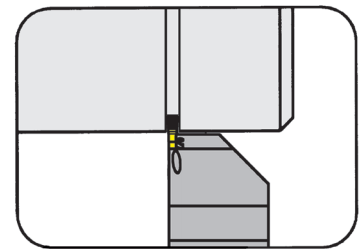

for Indexable insert

Type S315

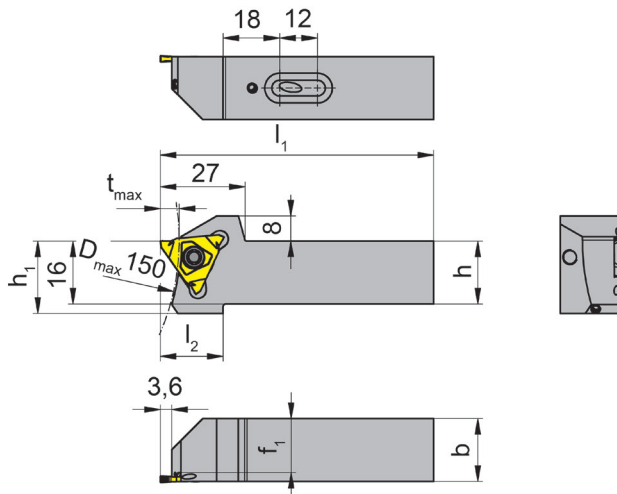

R = right hand version shown

L = left hand version

with integrated through
coolant supply

Part number	h	b	l ₁	l ₂	h ₁	f ₁	t _{max}	Size
R/L356.1616.S.4.03.IK	16	16	74	20	23	13.2	6	03
R/L356.2020.S.4.03.IK	20	20	87	20	23	17.2	6	03
R/L356.2525.S.4.03.IK	25	25	104	20	28	22.2	6	03

State R or L version

Dimensions in mm

Ordering note:

Use right hand inserts in left hand toolholders and left hand inserts in right hand toolholders

For torque specification of the screw, please see Technical Instructions.

Spare Parts

Toolholder	Clamping Screw	O - ring	TORX PLUS® Wrench
R/L356...	5.12T20P	12.37.2.62.3601	T20PQ

Grooving Corner Reliefs (external)



Toolholder

356

Corner reliefs (45°)

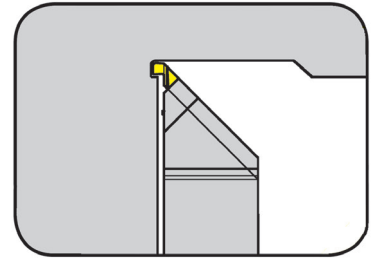

for Indexable insert

Type RA315
LA315

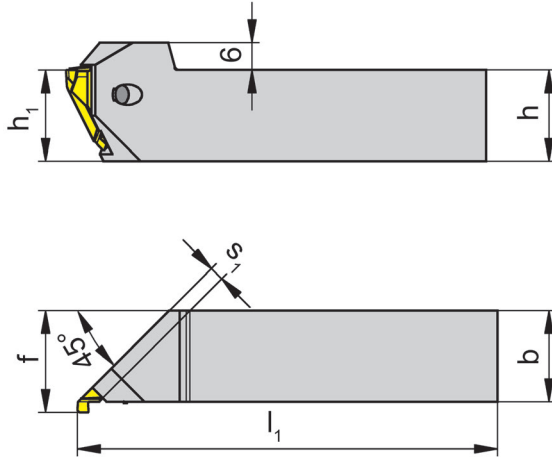

R = right hand version shown

L = left hand version

Part number	h	b	l ₁	h ₁	f	s ₁	Size
R/L356.2020.45.03	20	20	125	20	22.3	3.25	03
R/L356.2525.45.03	25	25	150	25	27.3	3.25	03

State R or L version

Dimensions in mm

Ordering note:

Use right hand inserts in left hand toolholders and left hand inserts in right hand toolholders

For torque specification of the screw, please see Technical Instructions.

Spare Parts

Toolholder	Clamping Screw	TORX PLUS® Wrench
R/L356...	5F.08T20P	T20PQ

Toolholder

U333

Bore Ø from
Width of groove

1.693"
.049 - .208"

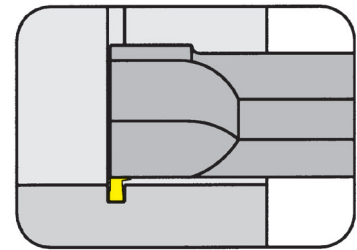

for Indexable insert

Type 315

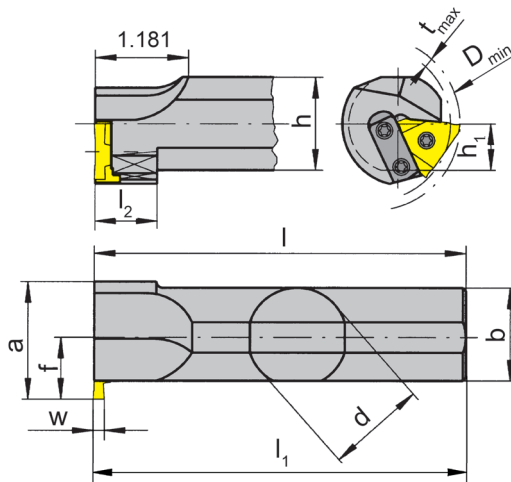

R = right hand version shown

L = left hand version

Depth of groove in relation to bore Ø

D _{min}	t _{max}
1.693	.070
1.811	.079
1.968	.118
2.362	.157
3.149	.177
4.000	.197

Part number	d	l ₁	l ₂	h	a	h ₁	f	D _{min}	b	Size
R/LU333.1000.05	1.000	6.705	.787	.921	1.654	.461	.945	1.693	1.000	05
R/LU333.1250.05	1.250	8.004	.787	1.171	1.496	.586	.787	1.693	1.174	05
R/LU333.1500.05	1.500	10.012	-	1.421	1.732	.711	.945	1.693	1.457	05

State R or L version

w see indexable inserts

Dimensions in inch

Further sizes upon request

Ordering note:

Use right hand inserts in left hand toolholders and left hand inserts in right hand toolholders

For torque specification of the screw, please see Technical Instructions.

Spare Parts

Toolholder	Attachment bar	Clamping Screw	TORX PLUS® Wrench
R/LU333...	020.7000.0193	5.12T20P	T20PQ

Grooving/Threading (internal)



Toolholder

333

Bore \varnothing from
Width of groove

43 mm
0.5 - 5.3 mm

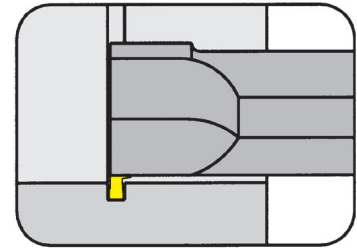

P

for Indexable insert

Type 315
LA315
RA315

Depth of groove in relation to bore \varnothing

D_{min}	t_{max}
43	1,8
46	2,0
50	3,0
60	4,0
80	4,5
100	5,0

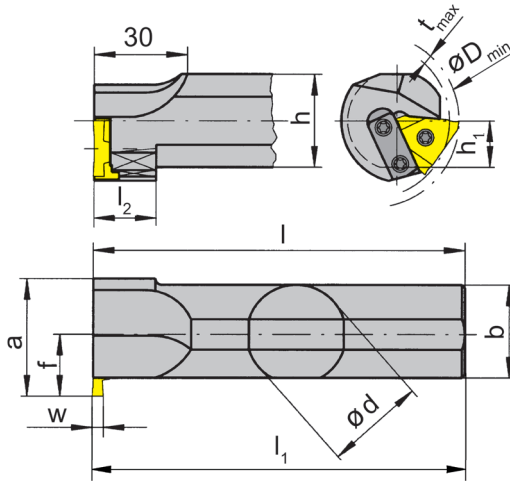

R = right hand version shown

L = left hand version

Part number	d	l	l_1	l_2	h	a	h_1	f	D_{min}	b	Size
R/L333.0025.03	25	170	170.3	20	23	38	11.5	20	43	25	03
R/L333.0032.03	32	200	200.3	20	30	38	15.0	20	43	30	03
R/L333.0025.05	25	170	170.3	20	23	38	11.5	20	43	25	05
R/L333.0032.05	32	200	200.3	20	30	38	15.0	20	43	30	05
R/L333.0040.05	40	250	250.3	-	38	44	19.0	24	45	38	05

State R or L version

w see indexable inserts

Dimensions in mm

Further sizes upon request

Ordering note:

Use right hand inserts in left hand toolholders and left hand inserts in right hand toolholders

For torque specification of the screw, please see Technical Instructions.

Spare Parts

Toolholder	Attachment bar	Clamping Screw	TORX PLUS® Wrench
R/L333...	020.7000.0193	5.12T20P	T20PQ

Cartridge

357

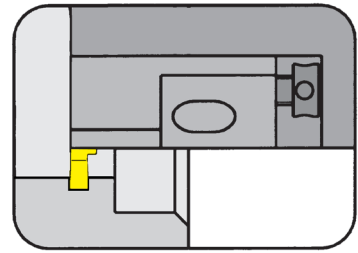

Bore \varnothing from 50 mm
Width of groove 0.5 - 5.3 mm

for Indexable insert

Type 315

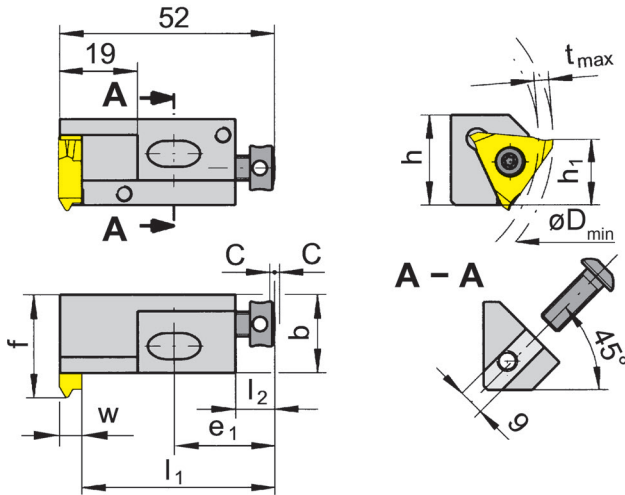

Depth of groove in relation to bore \varnothing	
D_{min}	t_{max}
50	3,0
60	4,0
80	4,5
100	5,0

R = right hand version shown

L = left hand version

Part number	h	b	h_1	f	l_1	E_1	l_2	C	Size
R/L357.1619.05	21	19	16	25	46.8	24	9	2	05

State R or L version

w see indexable inserts

Dimensions in mm

Dimensions of seating see following page

Ordering note:

Use right hand inserts in left hand toolholders and left hand inserts in right hand toolholders

For torque specification of the screw, please see Technical Instructions.

Spare Parts

Cartridge	Clamping Screw	Allen wrench	Screw	TORX PLUS® Wrench
R/L357.1619.05	4.08.913	SW2,0 DIN911	6.12.020	T20PQ

Seating Dimensions Cartridge

357

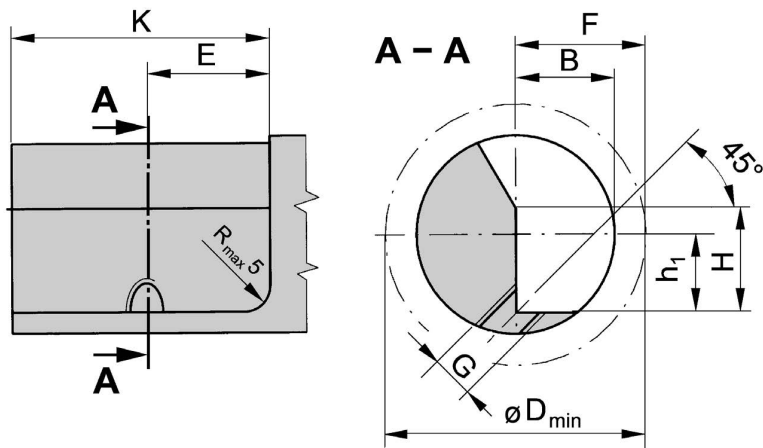
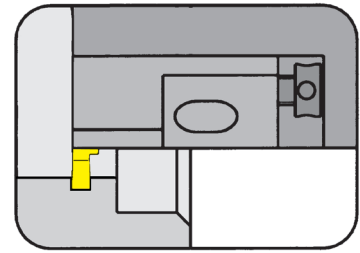

Part number	F	G	H	K	E	B	h_1	D_{min}	Fastening Screw
357.1619.05	25	M8	21	50	24	19	16	50	8.25.351

Dimensions in mm

Indexable insert

315

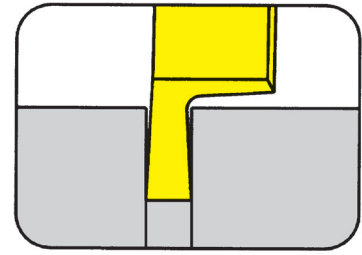

Circlip grooves
Width of circlip Nw

DIN471/472
.012 - .039"

for Toolholder

Type 356
357
333

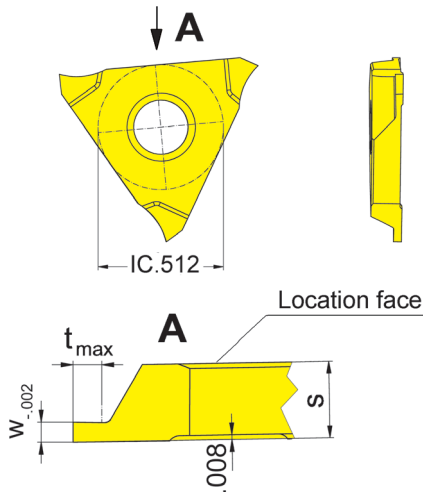

R = right hand version shown

L = left hand version

Part number	w	Nw	t _{max}	s	Size	TN32
R/L315.0034.32.00	.013	.012	.024	.126	03	Δ/Δ
R/L315.0044.32.00	.017	.016	.028	.126	03	Δ/Δ
R/L315.0050.32.00	.022	.020	.028	.126	03	▲/Δ
R/L315.0060.32.00	.026	.024	.031	.126	03	Δ/Δ
R/L315.0070.32.00	.030	.028	.043	.126	03	▲/Δ
R/L315.0080.32.00	.034	.031	.047	.126	03	▲/Δ
R/L315.0090.32.00	.038	.035	.055	.126	03	Δ/Δ
R/L315.0100.32.00	.042	.039	.063	.126	03	▲/Δ

- ▲ on stock Δ 4 weeks x upon request
- recommended
- o alternative recommendation
- not suitable
- uncoated grades
- coated grades
- brazed/Cermet

P	●
M	-
K	-
N	-
S	-
H	-

Dimensions in inch

State R or L version

Carbide grades

External machining:

Right hand insert in right hand toolholder 356, left hand insert in left hand toolholder 356.

Grooving (external and internal)



Indexable insert

315

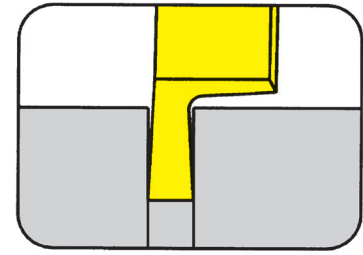

Circlip grooves
Width of circlip Nw

DIN471/472
.043 - .203"

for Toolholder

Type 356
357
333

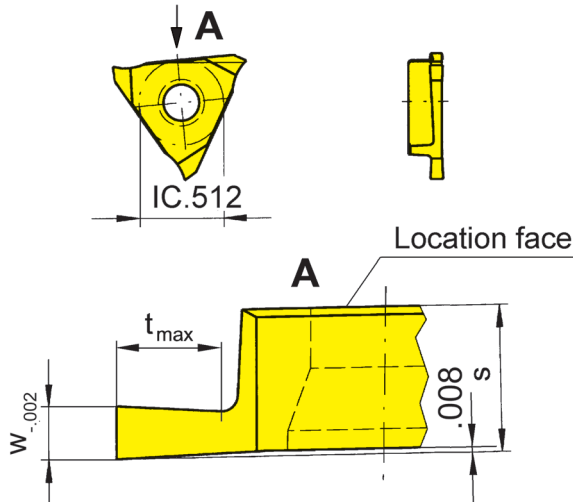

R = right hand version shown

L = left hand version

Part number	w	Nw	t _{max}	s	Size	Carbide grades					
						AL96	AS42	AS46	TC92	TF45	TN35
R/L315.0110.00	.049	.043	.079	.213	05	x/x	Δ/Δ	x/x	x/x	▲/Δ	▲/▲
R/L315.0130.00	.057	.051	.079	.213	05	x/x	Δ/Δ	x/x	x/x	▲/Δ	▲/▲
R/L315.0160.00	.069	.063	.118	.213	05	x/x	Δ/Δ	Δ/x	x/x	x/Δ	▲/▲
R/L315.0185.00	.078	.073	.118	.213	05	x/x	Δ/Δ	x/x	x/x	Δ/Δ	▲/▲
R/L315.0215.00	.090	.085	.157	.213	05	x/x	▲/Δ	x/x	x/x	x/Δ	▲/▲
R/L315.0265.00	.110	.104	.157	.213	05	x/x	Δ/Δ	x/x	x/x	Δ/Δ	▲/▲
R/L315.0315.00	.130	.124	.197	.213	05	x/x	Δ/Δ	x/x	x/x	▲/Δ	▲/▲
R/L315.0415.00	.169	.163	.197	.213	05	x/x	Δ/Δ	x/x	x/x	▲/x	▲/▲
L315.0515.00	.208	.203	.197	.213	05			x			

▲ on stock Δ 4 weeks x upon request

- recommended
- alternative recommendation
- not suitable

- uncoated grades
- coated grades
- brazed/Cermet

Dimensions in inch

State R or L version

Carbide grades

External machining:

Right hand insert in right hand toolholder 356, left hand insert in left hand toolholder 356.

Internal machining:

Right hand insert in left hand toolholder 333/357, left hand insert in right hand toolholder 333/357.

Indexable insert

315

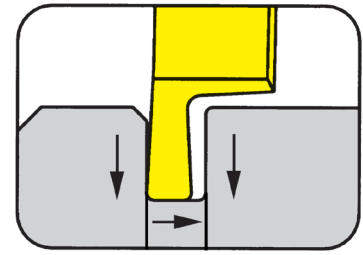

Depth of groove up to .197"
Width of groove .079 - .315"

for Toolholder

Type 356
357
333

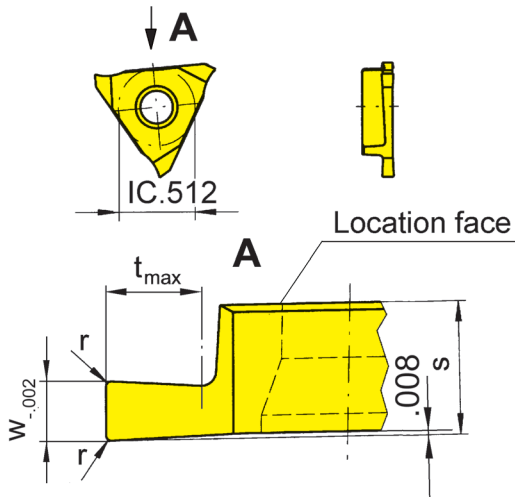

R = right hand version shown

L = left hand version

Indexability length
± .0008"

Part number	w	r	t _{max}	s	Size	Carbide grades						
						AL96	AS42	AS45	AS46	TC92	TF45	TN35
R/L315.0200.02	.079	.008	.118	.213	05	x/x	▲/▲		Δ/x	x/x	x/x	▲/▲
R/L315.0200.04	.079	.016	.118	.213	05	x/x	Δ/Δ		x/x	x/x	x/x	▲/Δ
R/L315.0300.02	.118	.008	.157	.213	05	x/x	▲/Δ		x/x	x/x	x/x	▲/▲
R/L315.0300.04	.118	.016	.157	.213	05	x/x	Δ/x		Δ/x	x/x	Δ/x	Δ/Δ
R/L315.0400.02	.157	.008	.197	.213	05		Δ/▲		x/x			▲/▲
R/L315.0400.04	.157	.016	.197	.213	05		Δ/Δ		x/x			▲/▲
R/L315.0500.02	.197	.008	.197	.213	05			Δ/Δ				
R/L315.0600.04	.236	.016	.197	.252	06			Δ/▲				
R/L315.0800.04	.315	.016	.197	.331	07			Δ/Δ				
						P	•	•	•	○	•	•
						M	-	•	•	○	-	•
						K	•	•	•	•	-	•
						N	•	•	○	○	-	•
						S	-	•	•	○	-	•
						H	-	-	-	-	-	-

▲ on stock Δ 4 weeks x upon request
 • recommended
 ○ alternative recommendation
 - not suitable
 uncoated grades
 coated grades
 brazed/Cermet

Dimensions in inch

State R or L version

Carbide grades

External machining:

Right hand insert in right hand toolholder 356, left hand insert in left hand toolholder 356.

Internal machining:

Right hand insert in left hand toolholder 333/357, left hand insert in right hand toolholder 333/357.

Grooving and Profiling (Full radius)



Indexable insert

315

with round chip breaker

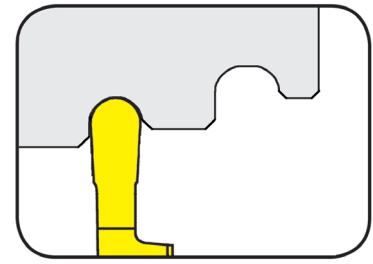

Depth of groove up to $.197''$
Full radius $.020 - .079''$

for Toolholder

Type 356
333
357

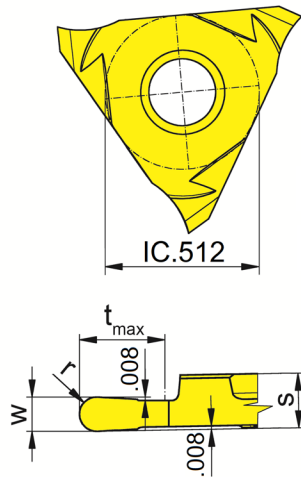

R = right hand version shown

L = left hand version

Indexability length
 $\pm .0008''$

Part number	w	t _{max}	r	s	Size	AS45
R/L315.0100.05	.039	.098	.020	.126	03	▲/▲
R/L315.0120.06	.047	.118	.024	.126	03	▲/▲
R/L315.0150.07	.059	.197	.030	.126	03	▲/▲
R/L315.0160.08	.063	.197	.031	.126	03	▲/△
R/L315.0180.09	.071	.197	.035	.126	03	△/△
R/L315.0200.10	.079	.197	.039	.126	03	▲/▲
R/L315.0220.11	.087	.197	.043	.126	03	△/△
R/L315.0250.12	.098	.197	.049	.126	03	▲/▲
R/L315.0280.14	.110	.197	.055	.126	03	▲/△
R/L315.0300.15	.118	.197	.059	.126	03	▲/△
R/L315.0360.18	.142	.197	.071	.213	05	△/△
R/L315.0400.20	.157	.197	.079	.213	05	△/△

▲ on stock △ 4 weeks x upon request

● recommended
○ alternative recommendation
- not suitable

□ uncoated grades
■ coated grades
■ brazed/Cermet

State R or L version

P	•
M	•
K	•
N	○
S	•
H	-

Carbide grades

Dimensions in inch

Further radii upon request

Note:

Width of groove up to $.063''$ recommended only for grooving

Indexable insert

A315

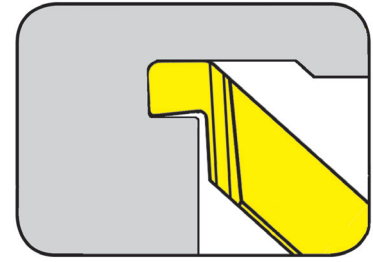

from outer groove \varnothing
Depth of groove up to
Width of groove

.315"
.079"
.059 - .094"

for Toolholder

Type 356...45.03

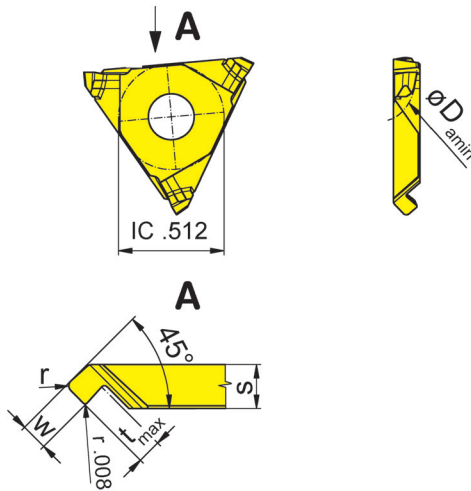

L = left hand version shown

R = right hand version

Indexability length
 $\pm .0008''$

Part number	w	r	t _{max}	D _{a min}	s	Size	TH35	TN35
LA315.0815.45.04R	.059	.016	.063	.315	.128	03	▲	▲
RA315.0815.45.04L	.059	.016	.063	.315	.128	03	▲	▲
LA315.1220.45.05R	.079	.020	.071	.472	.128	03	▲	▲
RA315.1220.45.05L	.079	.020	.071	.472	.128	03	▲	▲
LA315.2024.45.06R	.094	.024	.079	.787	.128	03	▲	▲
RA315.2024.45.06L	.094	.024	.079	.787	.128	03	▲	▲

▲ on stock Δ 4 weeks x upon request

● recommended
o alternative recommendation
- not suitable

□ uncoated grades
■ coated grades
■ brazed/Cermet

Dimensions in inch

	TH35	TN35
P	•	•
M	•	•
K	•	•
N	•	•
S	•	•
H	-	-

Carbide grades

Use right hand inserts in left hand toolholders and left hand inserts in right hand toolholders

The undercut must be placed BEFORE the axial machining!

Indexable insert

A315

Depth of groove up to .118"
Width of groove .059 - .118"

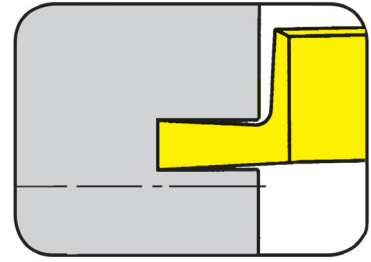

for Toolholder

Type 357
356...03-07

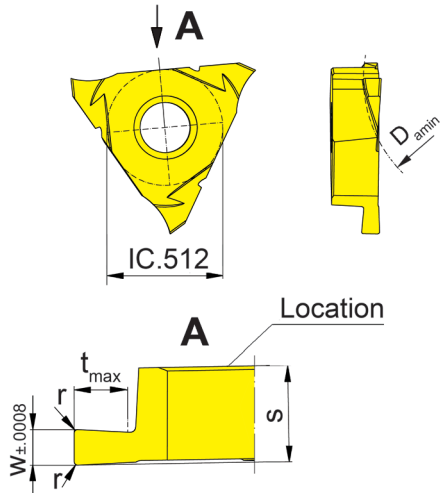

R = right hand version shown

Part number	w	r	t _{max}	D _{a min}	s	Size	TH35	TN35
LA315.2015.02R	.059	.008	.079	.787	.213	05		
RA315.2015.02L	.059	.008	.079	.787	.213	05	▲	
LA315.3020.02R	.079	.008	.118	1.181	.213	05		
RA315.3020.02L	.079	.008	.118	1.181	.213	05	▲	
LA315.3030.02R	.118	.008	.118	1.181	.213	05		
RA315.3030.02L	.118	.008	.118	1.181	.213	05	▲	

- ▲ on stock Δ 4 weeks x upon request
- recommended
- alternative recommendation
- not suitable
- uncoated grades
- coated grades
- brazed/Cermet

	TH35	TN35
P	●	●
M	●	●
K	●	●
N	●	●
S	●	●
H	-	-

Dimensions in inch

Carbide grades

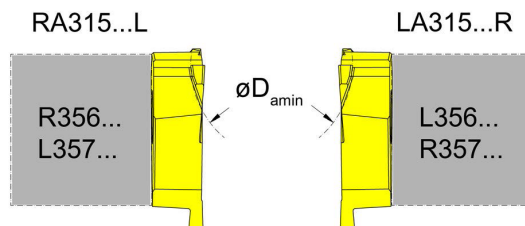

Indexable insert

A315

from outer groove \varnothing
Depth of groove up to
Width of groove

1.181"
.118"
.059 - .118"

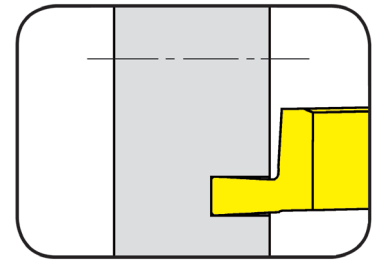

for Toolholder

Type 356
357

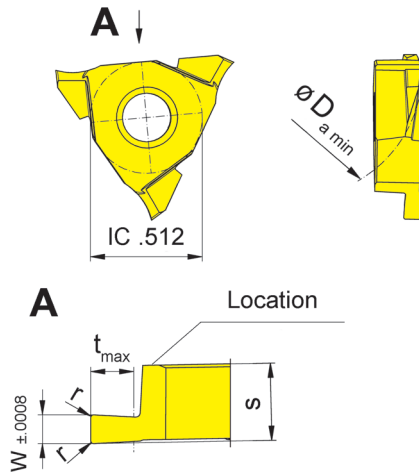

R = right hand version shown

L = left hand version

Indexability length
 $\pm .0008''$

Part number	w	r	t_{\max}	$D_{a \min}$	s	Size	TH35	TN35
RA315.2015.02R	.059	.008	.079	.787	.213	05	Δ/Δ	
RA315.3020.02R	.079	.008	.118	1.181	.213	05	Δ/Δ	x/x
RA315.3030.02R	.118	.008	.118	1.181	.213	05	Δ/Δ	

\blacktriangle on stock Δ 4 weeks x upon request

\bullet recommended

o alternative recommendation

- not suitable

□ uncoated grades

■ coated grades

■ brazed/Cermet

Dimensions in inch

	TH35	TN35
P	\bullet	\bullet
M	\bullet	\bullet
K	\bullet	\bullet
N	\bullet	\bullet
S	\bullet	\bullet
H	-	-

Carbide grades

Threading (external) Partial profile



Indexable insert

315

Metric ISO - thread

Pitch	1.0 - 6.0 mm
-------	--------------

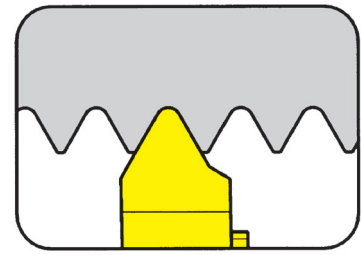

for Toolholder

Type 356
357
333

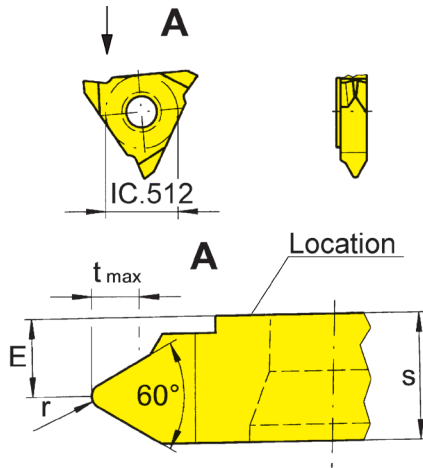

R = right hand version shown

L = left hand version

Part number	P, mm	P _{max} ¹ mm	E	r	t _{max}	s	Size	TN35
R/L315.0610.01	1.00	1.00	.177	.006	.024	.215	05	▲/Δ
R/L315.0712.01	1.25	1.25	.177	.006	.030	.215	05	▲/Δ
R/L315.0915.01	1.50	1.50	.163	.008	.036	.215	05	▲/▲
R/L315.1017.01	1.75	1.75	.163	.010	.042	.215	05	▲/Δ
R/L315.1220.01	2.00	2.00	.163	.010	.048	.215	05	▲/Δ
R/L315.1525.01	2.50	2.50	.150	.014	.060	.215	05	▲/Δ
R/L315.1830.01	3.00	3.00	.142	.016	.072	.215	05	▲/Δ
R/L315.3060.01	3.00	6.00	.118	.016	.163	.240	05	▲/▲
R/L315.2135.01	3.50	3.50	.134	.020	.085	.215	05	Δ/x

▲ on stock Δ 4 weeks x upon request

- recommended
- alternative recommendation
- not suitable

- uncoated grades
- coated grades
- brazed/Cermet

Dimensions in inch

State R or L version

Carbide grades

P	•
M	•
K	•
N	•
S	•
H	-

No shims necessary. All HORN thread profiles are manufactured with **fully ground radial clearance**.

External machining:

Right hand insert in right hand toolholder 356, left hand insert in left hand toolholder 356.

Threading (external) Full profile



Indexable insert

315

Metric ISO - thread

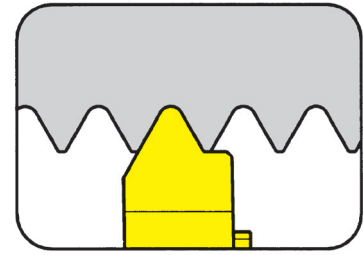

for Toolholder

Type 356

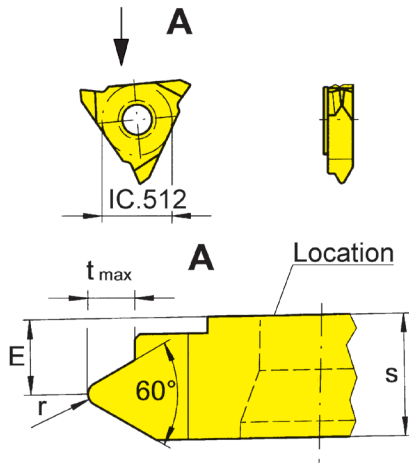

R = right hand version shown

L = left hand version

Part number	P mm	E	r	t _{max}	s	Size	TN35
R/L315.0610.02	1.0	.177	.006	.024	.215	05	▲/▲
R/L315.0712.02	1.25	.177	.006	.030	.215	05	▲/Δ
R/L315.0915.02	1.50	.163	.008	.036	.215	05	▲/▲
R/L315.1017.02	1.75	.163	.010	.042	.215	05	▲/Δ
R/L315.1220.02	2.00	.163	.010	.048	.215	05	▲/▲
R/L315.1525.02	2.50	.150	.014	.061	.215	05	▲/Δ
R/L315.1830.02	3.00	.142	.016	.072	.215	05	▲/▲
R/L315.2135.02	3.50	.134	.020	.085	.215	05	▲/Δ
R/L315.2440.02	4.00	.130	.022	.096	.215	05	▲/▲
R/L315.3050.02	5.00	.157	.028	.121	.256	06/07	▲/Δ
R/L315.3660.02	6.00	.161	.033	.145	.276	07	▲/Δ

▲ on stock Δ 4 weeks x upon request

- recommended
- alternative recommendation
- not suitable

- uncoated grades
- coated grades
- brazed/Cermet

P	•
M	•
K	•
N	•
S	•
H	-

Dimensions in inch

State R or L version

Carbide grades

No shims necessary. All HORN thread profiles are manufactured with **fully ground radial clearance**.

External machining:

Right hand insert in right hand toolholder 356, left hand insert in left hand toolholder 356.

Threading (internal) Partial profile



Indexable insert

315

Metric ISO - thread

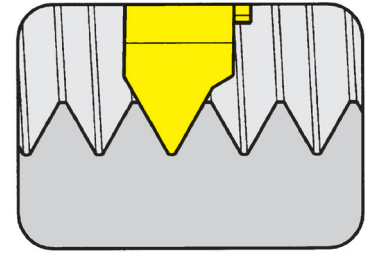

Pitch	1.0 - 3.5 mm
-------	--------------

for Toolholder

Type 357
333

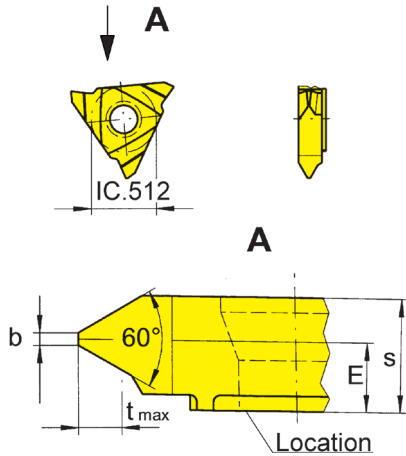

R = right hand version shown

L = left hand version

Part number	P mm	E	t _{max}	b	s	D _{min}	Size	TN35
R/L315.0510.01	1.00	.191	.022	.005	.215	1.575	05	Δx
R/L315.0815.01	1.50	.183	.032	.007	.215	1.575	05	ΔΔ
R/L315.1020.01	2.00	.175	.043	.010	.215	1.575	05	Δx
R/L315.1325.01	2.50	.167	.053	.012	.215	1.693	05	Δx
R/L315.1630.01	3.00	.159	.064	.015	.215	1.693	05	Δx
R/L315.1835.01	3.50	.154	.074	.017	.215	1.693	05	Δx

▲ on stock Δ 4 weeks x upon request

- recommended
- alternative recommendation
- not suitable

- uncoated grades
- coated grades
- brazed/Cermet

Dimensions in inch

State R or L version

Carbide grades

P	•
M	•
K	•
N	•
S	•
H	-

No shims necessary. All HORN thread profiles are manufactured with **full ground radial clearance**.

Internal machining:

Right hand insert in right hand toolholder 333/357, left hand insert in left hand toolholder 333/357

Threading (internal) Full profile



Indexable insert

315

Metric ISO - thread

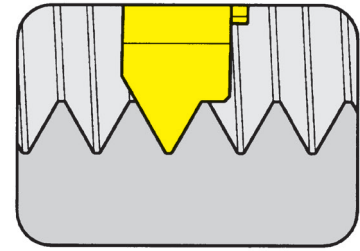

Pitch

1.0 - 3.50 mm

for Toolholder

Type 356
357
333

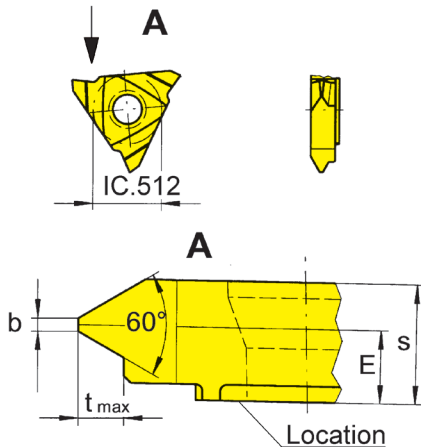

R = right hand version shown

L = left hand version

Part number	P mm	E	t _{max}	b	s	D _{min}	Size	TN35
R/L315.0510.02	1.00	.191	.022	.005	.215	1.575	05	Δ/x
R/L315.0815.02	1.50	.183	.032	.007	.215	1.575	05	▲/x
R/L315.1020.02	2.00	.175	.043	.010	.215	1.575	05	▲/Δ
R/L315.1325.02	2.50	.167	.053	.012	.215	1.693	05	▲/x
R/L315.1630.02	3.00	.159	.064	.015	.215	1.693	05	▲/Δ
R/L315.1835.02	3.50	.154	.074	.017	.215	1.693	05	Δ/x

▲ on stock Δ 4 weeks x upon request

- recommended
- alternative recommendation
- not suitable

- uncoated grades
- coated grades
- brazed/Cermet

Dimensions in inch

State R or L version

Carbide grades

P	•
M	•
K	•
N	•
S	•
H	-

No shims necessary. All HORN thread profiles are manufactured with **fully ground radial clearance**.

Internal machining:

Right hand insert in right hand toolholder 333/357, left hand insert in left hand toolholder 333/357

Threading (external) Full profile



Indexable insert

315

Whitworth pipe thread

Threads per inch	11 - 28
------------------	---------

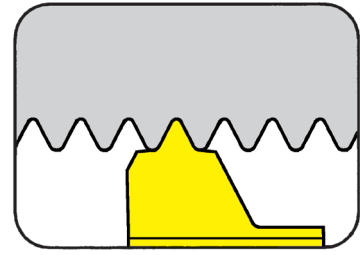

for Toolholder

Type 356

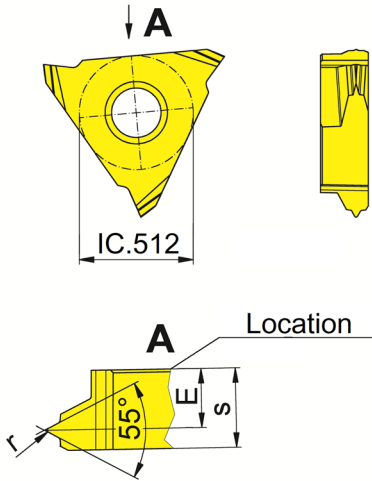

R = right hand version shown

L = left hand version

Part number	TPI	E	s	Size	TH35
R/L315.5528.02	28	.171	.215	05	▲▲▲
R/L315.5519.02	19	.159	.215	05	▲▲▲
R/L315.5514.02	14	.148	.215	05	▲▲▲
R/L315.5511.02	11	.140	.215	05	▲▲▲

▲ on stock Δ 4 weeks x upon request

- recommended
- alternative recommendation
- not suitable

- uncoated grades
- coated grades
- brazed/Cermet

Dimensions in inch

State R or L version

Carbide grades

P	•
M	•
K	•
N	•
S	•
H	-

No shims necessary. All HORN thread profiles are manufactured with **fully ground radial clearance**.

External machining:

Right hand insert in right hand toolholder 356, left hand insert in left hand toolholder 356.

Threading Full profile



Indexable insert

315

Pitch

1.50 - 6.00 mm

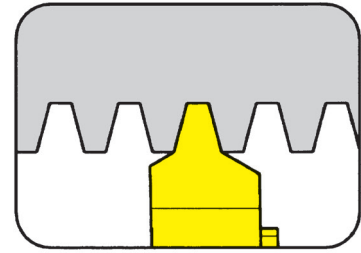

for Toolholder

Type 356
357
333

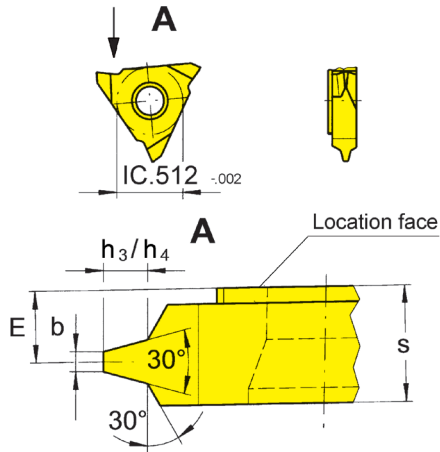

R = right hand version shown

L = left hand version

Metric ISO trapezoidal
thread DIN 103

Part number	P mm	E	b	s	D _{min}	Size	TN35
R/L315.1015.02	1.50	.177	.019	.215	1.693	05	▲/△
R/L315.1320.02	2.00	.169	.024	.215	1.693	05	▲/△
R/L315.1730.02	3.00	.157	.038	.215	1.693	05	▲/▲
R/L315.2240.02	4.00	.142	.052	.215	1.693	05	▲/▲
R/L315.2750.02	5.00	.130	.067	.215	1.693	05	▲/▲
R/L315.3560.02	6.00	.118	.076	.215	1.693	05	▲/▲

▲ on stock Δ 4 weeks x upon request

● recommended
o alternative recommendation
- not suitable

□ uncoated grades
■ coated grades
■ brazed/Cermet

Dimensions in inch

State R or L version

Carbide grades

P	•
M	•
K	•
N	•
S	•
H	-

No shims necessary. All HORN thread profiles are manufactured with **fully ground radial clearance**.

External machining:

Right hand insert in right hand toolholder 356, left hand insert in left hand toolholder 356.

Internal machining:

Right hand insert in left hand toolholder 333/357, left hand insert in right hand toolholder 333/357.

Indexable insert

315

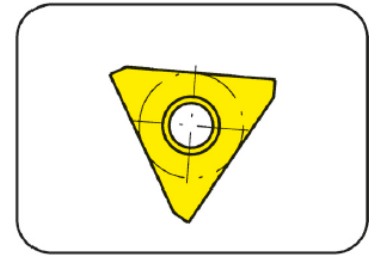

Basic sizes type 315

for Toolholder

Type 356

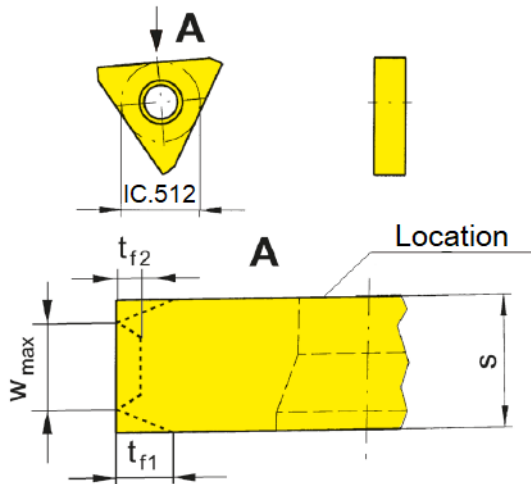

R = right hand version shown

L = left hand version

Part number	W _{max}	t _{f1}	t _{f2}	s	Size	TN35	TI25	TA45	TA46
						UPON REQUEST FOR ALL GRADES			
R/L315...	.120	.197	-	.128	03				
R/L315...	.207	.197	.079	.215	05				
R/L315...	.232	.197	.079	.240	05/06				
R/L315...	.252	.197	.079	.260	06/07				
R/L315...	.272	.197	.079	.280	07				
R/L315...	.287	.197	.079	.295	07				
R/L315...	.327	.197	.079	.335	07				
R/L315...	.366	.197	.079	.374	10				
R/L315...	.406	.197	.079	.413	10				
R/L315...	.524	.197	.079	.531	13				
R/L315...	.602	.197	.079	.610	13				

▲ on stock Δ 4 weeks x upon request

● recommended
o alternative recommendation
- not suitable

■ uncoated grades
■ coated grades
■ brazed/Cermet

P			
M			
K			
N			
S			
H			

Carbide grades

Dimensions in inch

State R or L version

Right hand insert in left hand toolholder 356, left hand insert in left hand toolholder 356 useable.

Grooving and Parting off (external)



Indexable insert

S315

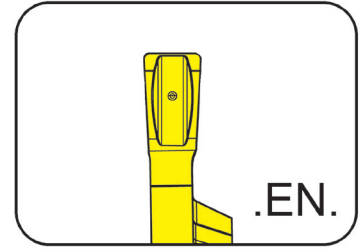

Depth of groove up to .217"
Width of groove up to .079"

precision sintered

for Toolholder

Type 356...S.4..

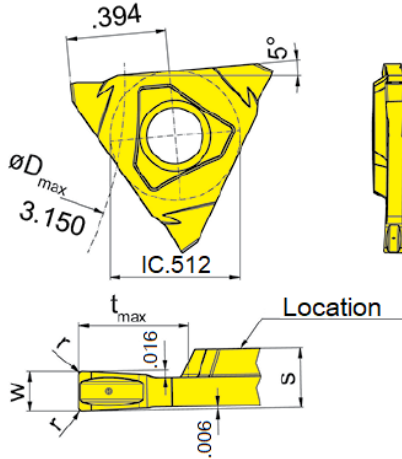

R = right hand version shown

L = left hand version

Part number	w	r	t _{max}	s	Size	EG5G
R/LS315.0200.EN2	.079	.008	.217	.118	03	▲/▲
						P ●
						M ○
						K ○
						N -
						S -
						H -

- ▲ on stock Δ 4 weeks x upon request
- recommended
- alternative recommendation
- not suitable

- uncoated grades
- coated grades
- brazed/Cermet

Dimensions in inch

Carbide grades

State R or L version

Indexable insert

S315

Depth of groove up to	.217"
Width of groove up to	.059"

precision sintered

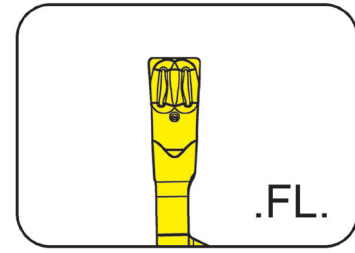

for Toolholder

Type 356...S.4..

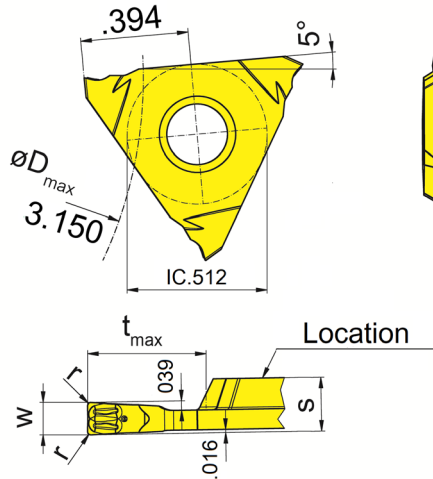

R = right hand version shown

L = left hand version

Part number	w	r	t _{max}	s	Size	EG55
R/LS315.0150.FL15	.059	.006	.217	.098	03	▲/▲
						P ●
						M ○
						K ○
						N -
						S -
						H -

- ▲ on stock Δ 4 weeks x upon request
- recommended
- alternative recommendation
- not suitable

- uncoated grades
- coated grades
- brazed/Cermet

Dimensions in inch

Carbide grades

State R or L version

Indexable insert

S315

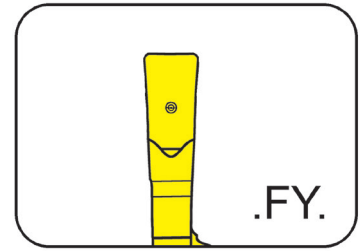

Depth of groove up to
Width of groove

.217"
.059 - .079"

precision sintered

for Toolholder

Type 356...S.4..

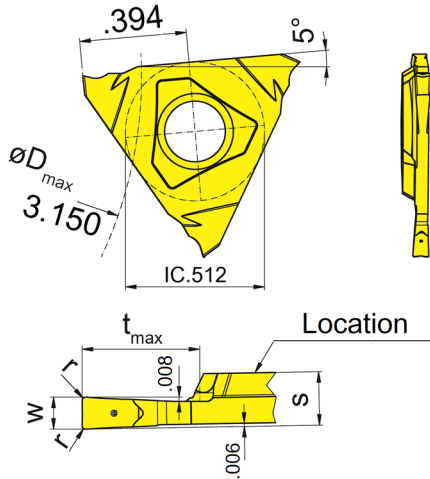

R = right hand version shown

L = left hand version

Part number	w	r	t _{max}	s	Size	EG55
R/LS315.0150.FY15	.059	.006	.217	.098	03	▲▲
R/LS315.0200.FY2	.079	.008	.217	.118	03	▲▲

▲ on stock Δ 4 weeks x upon request

- recommended
- alternative recommendation
- not suitable

- uncoated grades
- coated grades
- brazed/Cermet

Dimensions in inch

Carbide grades

State R or L version

Indexable insert

S315

Depth of groove up to .217"
Width of groove .043 - .079"

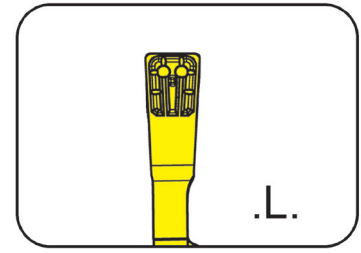

precision sintered

for Toolholder

Type 356...S.4..

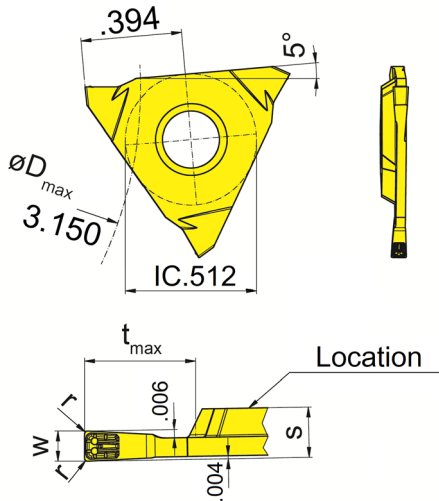

R = right hand version shown

L = left hand version

Part number	w	r	t _{max}	s	Size	EG55
R/LS315.0110.L1	.043	.004	.217	.098	03	▲▲
R/LS315.0130.L1	.051	.004	.217	.098	03	▲▲
R/LS315.0150.L15	.059	.006	.217	.098	03	▲▲
R/LS315.0200.L2	.079	.008	.217	.118	03	▲▲

▲ on stock Δ 4 weeks x upon request

- recommended
- alternative recommendation
- not suitable

- uncoated grades
- coated grades
- brazed/Cermet

Dimensions in inch

P	●
M	○
K	○
N	-
S	-
H	-

Carbide grades

State R or L version



P



316

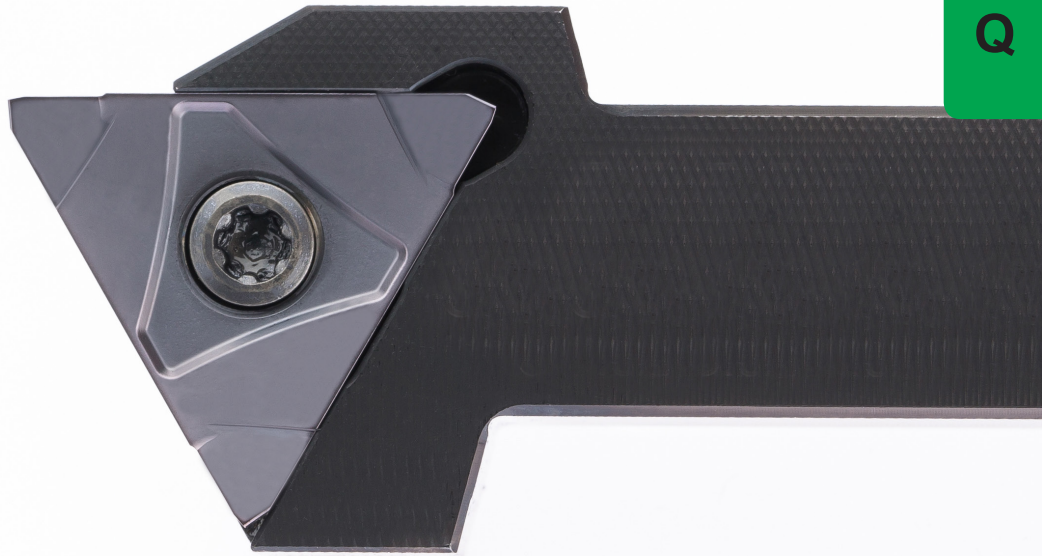

Toolholder with Inserts

Width of groove .059 - .118"

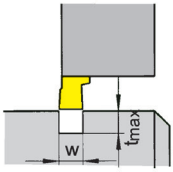

$w = .059 - .118"$
 (1.5 - 3.0 mm)
 $t_{max} = 0.315"$ (8.0 mm)



Toolholder
H316

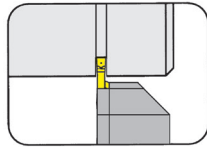

Page
Q3-Q5, Q10

Toolholder
HC316

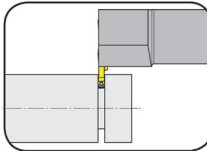

Page
Q6, Q11

Indexable Insert
S316

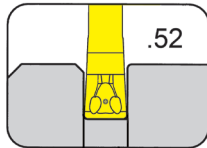

Page
Q7

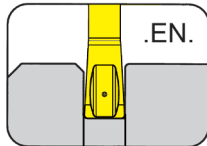

Page
Q8

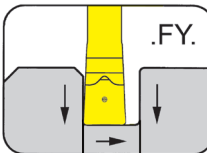

Page
Q9

Grooving (external)



Toolholder

HU316

Depth of groove up to .315"
Clamping range .059 - .118"

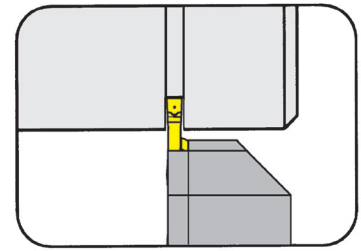

for Indexable insert

Type S316

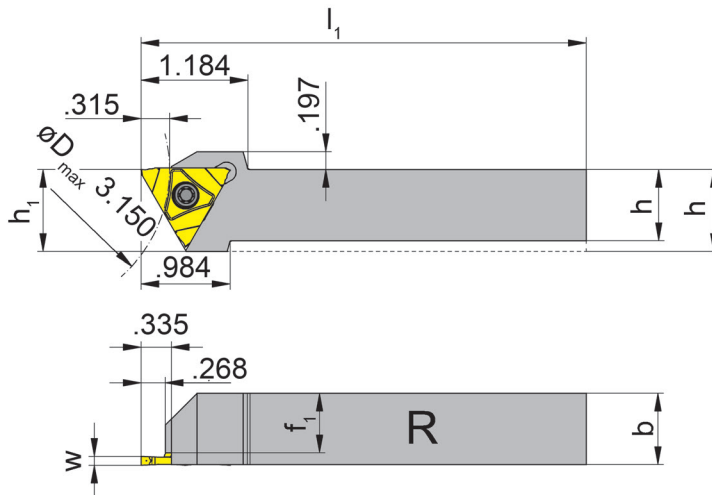

R = right hand version shown

L = left hand version

Part number	h	b	l ₁	h ₁	f ₁	Size
R/LHU316.0750.S3.03	.750	.750	5.000	.906	.620	03
R/LHU316.1000.S3.03	1.000	1.000	6.000	1.000	.870	03
R/LHU316.1250.S3.03	1.250	1.000	6.693	1.250	.870	03

State R or L version

w see indexable inserts

Dimensions in inch

Further sizes upon request

For torque specification of the screw, please see Technical Instructions.

Spare Parts

Toolholder	Clamping Screw	TORX PLUS® Wrench
R/LHU316...	5.12T20P	T20PQ

Grooving (external)



Toolholder

H316

Depth of groove up to
Clamping range

8 mm
1.5 - 3 mm

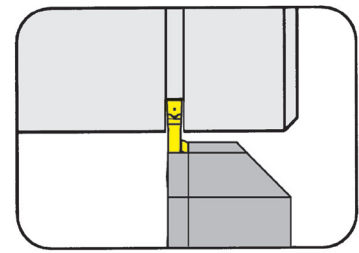

for Indexable insert

Type S316

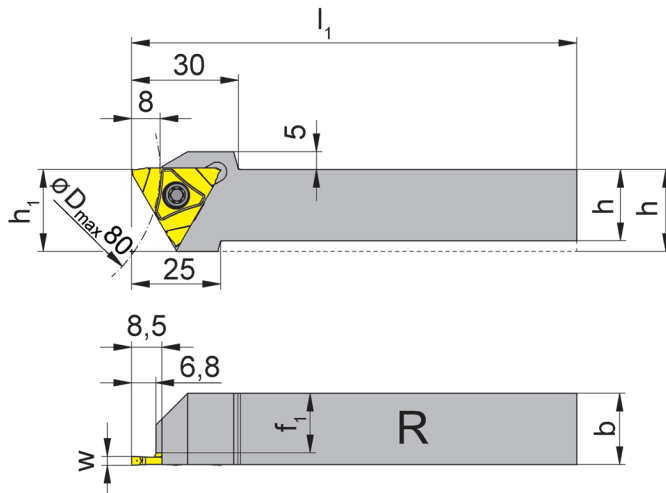

R = right hand version shown

L = left hand version

Part number	h	b	l_1	h_1	f_1	Size
R/LH316.1616.S3.03	16	16	125	23	12.7	03
R/LH316.2020.S3.03	20	20	125	23	16.7	03
R/LH316.2525.S3.03	25	25	150	25	21.7	03
R/LH316.3225.S3.03	32	25	150	32	21.7	03

State R or L version

w see indexable inserts

Dimensions in mm

Further sizes upon request

For torque specification of the screw, please see Technical Instructions.

Spare Parts

Toolholder	Clamping Screw	TORX PLUS® Wrench
R/LH316...	5.12T20P	T20PQ

Q4

Call Us Toll Free (888) 818-4676

Grooving (external)



Toolholder

H316

Depth of groove up to 8 mm
Clamping range 1.5 - 5 mm

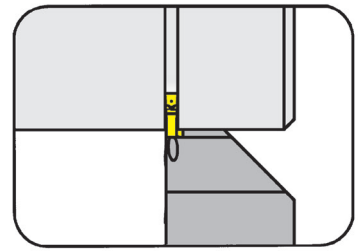

for Indexable insert

Type S316

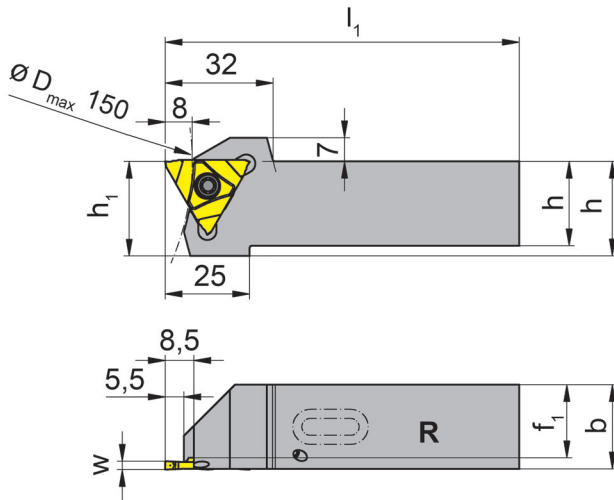

R = right hand version shown

L = left hand version

with integrated through coolant supply

Part number	h	b	l ₁	h ₁	f ₁	Size
R/LH316.2020.S3.03.IK	20	20	90	28	16.7	03
R/LH316.2525.S3.03.IK	25	25	105	28	21.7	03
R/LH316.2020.S5.05.IK	20	20	90	28	14.8	05
R/LH316.2525.S5.05.IK	25	25	105	28	19.8	05

State R or L version

w see indexable inserts

Dimensions in mm

Further sizes upon request

For torque specification of the screw, please see Technical Instructions.

Spare Parts

Toolholder	Clamping Screw	O-ring	TORX PLUS® Wrench
R/LH316...	5.12T20P	12.37.2.62.3601	T20PQ



Toolholder

HC316

Depth of groove up to
Width of groove

8 mm
1.5 - 3 mm

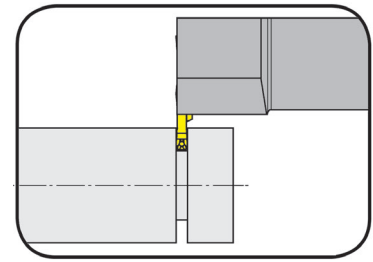

for Indexable insert

Type S316

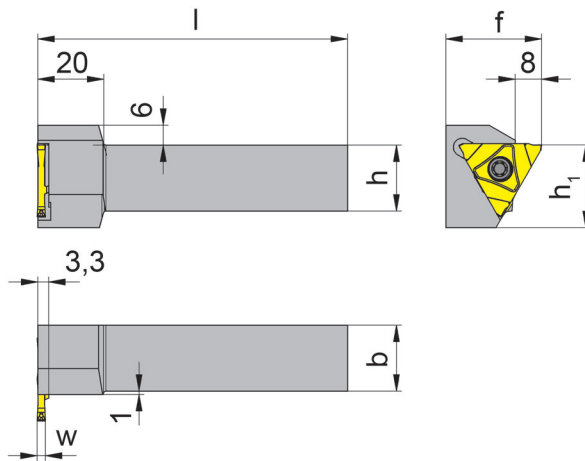

R = right hand version shown

L = left hand version

Part number	h	b	l	h ₁	f	Size
R/LHC316.1616.S3.03	16	16	125	25	29	03
R/LHC316.2020.S3.03	20	20	125	25	29	03
R/LHC316.2525.S3.03	25	25	150	25	34	03
R/LHC316.3225.S3.03	32	25	150	32	34	03

State R or L version

w see indexable inserts

Dimensions in mm

Further sizes upon request

For torque specification of the screw, please see Technical Instructions.

Spare Parts

Toolholder	Clamping Screw	TORX PLUS® Wrench
R/LHC316...	5.12T20P	T20PQ

Indexable insert

S316

Depth of groove up to	.315"
Width of groove	.079 - .118"

precision sintered

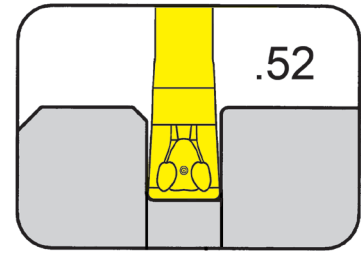

for Toolholder

Type H316/HU316
HC316
NK316

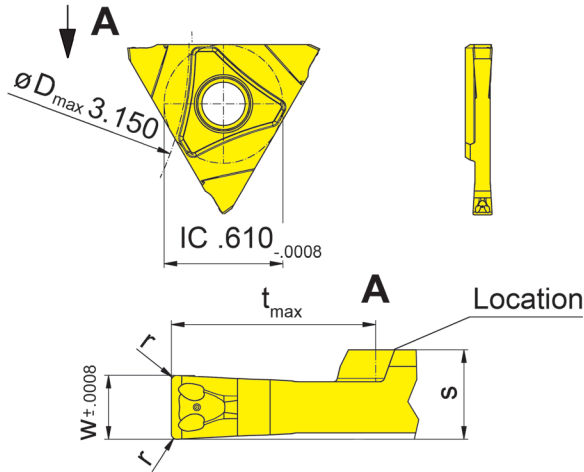

R = right hand version shown

L = left hand version

Indexability length
± .0008"

Part number	w	r	t _{max}	s	Size	AS45
R/LS316.0200.52	.079	.008	.315	.138	03	▲▲
R/LS316.0250.52	.098	.008	.315	.138	03	▲▲
R/LS316.0300.52	.118	.008	.315	.138	03	▲▲
						P ●
						M ●
						K ●
						N ○
						S ●
						H -

- ▲ on stock Δ 4 weeks x upon request
- recommended
- alternative recommendation
- not suitable
- uncoated grades
- coated grades
- brazed/Cermet

Dimensions in inch

State R or L version

Carbide grades

External machining:

Use right hand inserts in right hand toolholders and left hand inserts in left hand toolholders



Indexable insert

S316

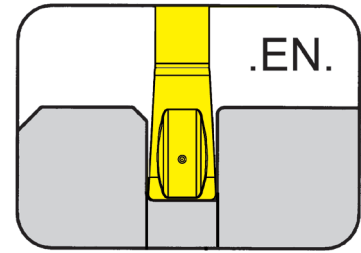

Depth of groove up to	.315"
Width of groove	.079 - .118"

precision sintered

for Toolholder

Type H316/HU316
HC316
NK316

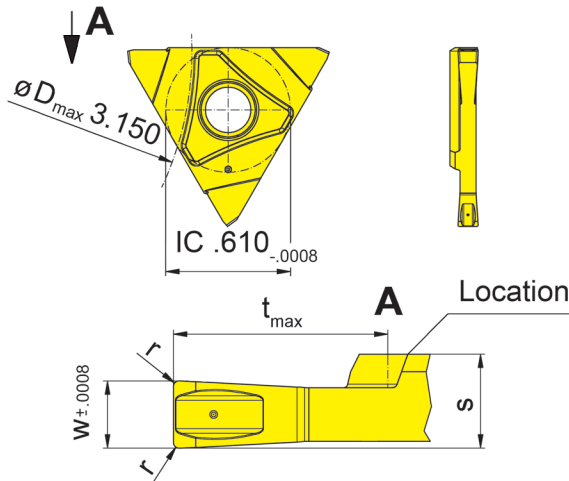

R = right hand version shown

L = left hand version

Indexability length
 $\pm .0008''$

Part number	w	r	t_{max}	s	Size	AS6G
R/LS316.0200.EN2	.079	.008	.315	.138	03	▲▲
R/LS316.0250.EN2	.098	.008	.315	.138	03	▲▲
R/LS316.0300.EN2	.118	.008	.315	.138	03	▲▲

- ▲ on stock Δ 4 weeks x upon request
- recommended
- alternative recommendation
- not suitable
- uncoated grades
- coated grades
- brazed/Cermet

P	•
M	•
K	•
N	•
S	•
H	-

Dimensions in inch

State R or L version

Carbide grades

External machining:

Use right hand inserts in right hand toolholders and left hand inserts in left hand toolholders

Indexable insert

S316

Depth of groove up to $.315''$
 Width of groove $.059 - .118''$

precision sintered

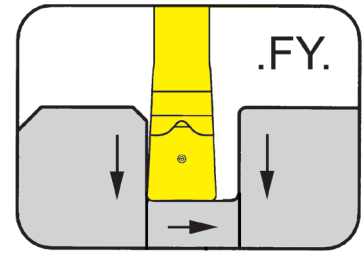

for Toolholder

Type H316/HU316
 HC316
 NK316

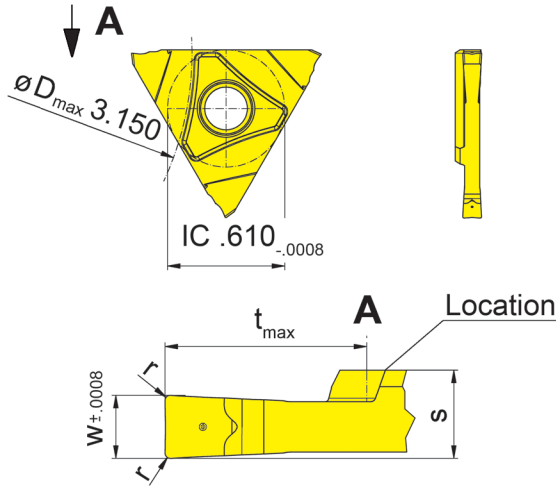

R = right hand version shown

L = left hand version

Indexability length
 $\pm .0008''$

Part number	w	r	t_{max}	s	Size	TI25
R/LS316.0150.FY1	.059	.004	.315	.130	03	▲▲
R/LS316.0200.FY2	.079	.008	.315	.138	03	▲▲
R/LS316.0250.FY2	.098	.008	.315	.138	03	▲▲
R/LS316.0300.FY2	.118	.008	.315	.138	03	▲▲

▲ on stock Δ 4 weeks x upon request

- recommended
- alternative recommendation
- not suitable

- uncoated grades
- coated grades
- brazed/Cermet

P	•
M	•
K	•
N	•
S	•
H	-

Dimensions in inch

State R or L version

Carbide grades

External machining:

Use right hand inserts in right hand toolholders and left hand inserts in left hand toolholders

Toolholder

H316

Depth of groove up to
Clamping range

8 mm
1.5 - 3 mm

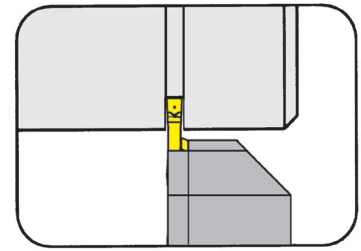

for Indexable insert

Type 316 Special

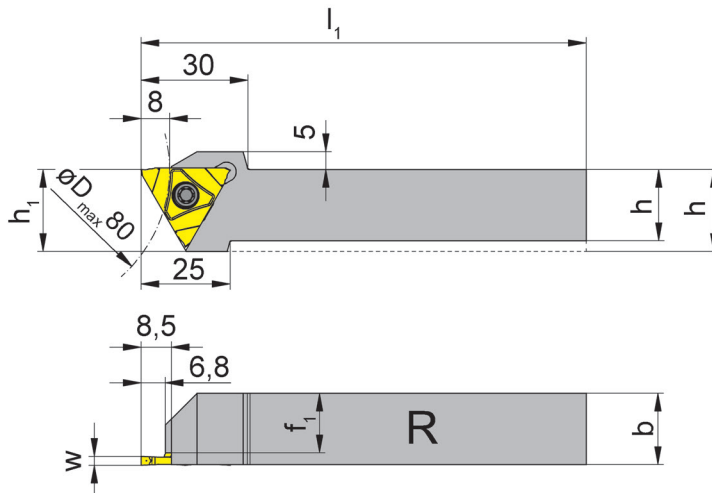

R = right hand version shown

L = left hand version

only for peripheral ground
profiled inserts

Part number	h	b	l ₁	h ₁	f ₁	Size
R/LH316.1616.03	16	16	125	23	12.7	03
R/LH316.2020.03	20	20	125	23	16.7	03
R/LH316.2525.03	25	25	150	25	21.7	03
R/LH316.3225.03	32	25	150	32	21.7	03

State R or L version

w see indexable inserts

Dimensions in mm

Further sizes upon request

For torque specification of the screw, please see Technical Instructions.

Spare Parts

Toolholder	Clamping Screw	TORX PLUS® Wrench
R/LH316...	5.12T20P	T20PQ

Toolholder

HC316

Depth of groove up to
Width of groove

8 mm
1.5 - 3 mm

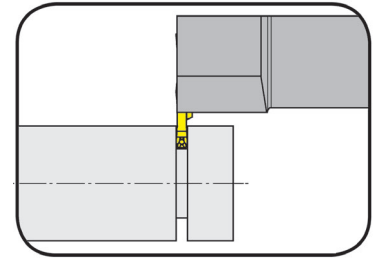

for Indexable insert

Type 316 Special

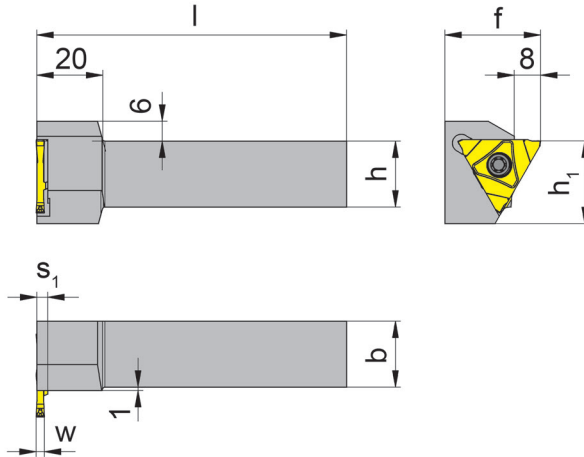

R = right hand version shown

L = left hand version

only for peripheral ground
profiled inserts

Part number	h	b	l	h ₁	f	s ₁	Size
R/LHC316.1616.03	16	16	125	25	29	3.3	03
R/LHC316.2020.03	20	20	125	25	29	3.3	03
R/LHC316.2525.03	25	25	150	25	34	3.3	03
R/LHC316.3225.03	32	25	150	32	34	3.3	03
R/LHC316.2020.05	20	20	125	25	29	5.2	05
R/LHC316.2525.05	25	25	150	25	34	5.2	05
R/LHC316.3225.05	32	25	150	32	34	5.2	05

State R or L version

w see indexable inserts

Dimensions in mm

Further sizes upon request

Ordering note:

Use right hand inserts in right hand toolholders and left hand inserts in left hand toolholders

For torque specification of the screw, please see Technical Instructions.

Spare Parts

Toolholder	Clamping Screw	TORX PLUS® Wrench
R/LHC316...	5.12T20P	T20PQ

Q



64T



Toolholder with Inserts

Width of groove .020 - .124"

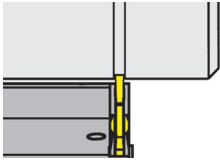

$w = .02 - .118" (0.5 - 3.0 \text{ mm})$
 $t_{\text{max}} = .217" (5.5 \text{ mm})$

Toolholder
H64T

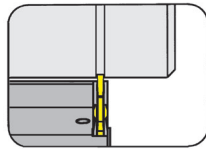

Page
R3-R4

Indexable Insert
S64T

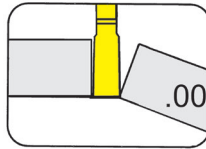

Page
R5

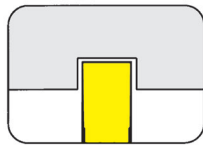

Page
R6

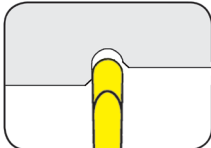

Page
R7

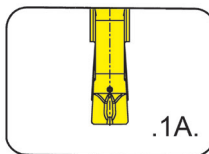

Page
R8

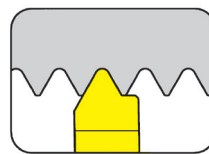

Page
R11

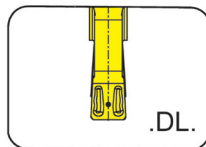

Page
R9

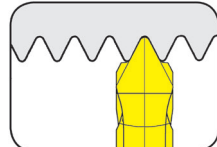

Page
R12

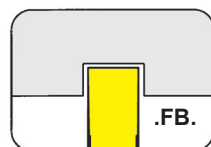

Page
R10

R

Toolholder

H64T

with through coolant supply

Depth of groove up to

5.5 mm

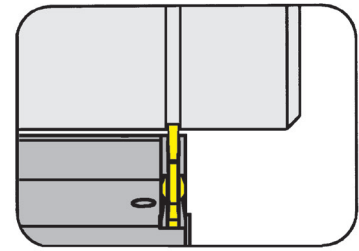

for Indexable insert

Type S64T

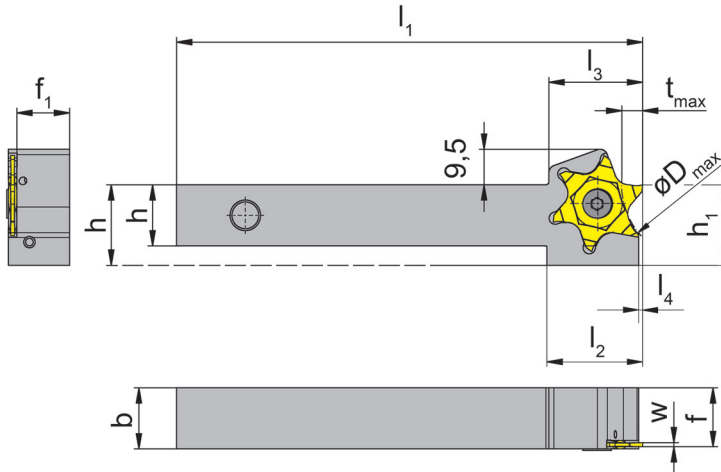

Grooving and Parting off

D _{max}	t _{max}
40	5.5
45	5.5
50	4.5
55	4.0
65	3.5
70	3.5
80	3.5
100	2.5

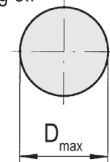

L = left hand version shown

R = right hand version

Part number	h	b	l ₁	l ₂	l ₃	h ₁	f ₁	f	l ₄	Coolant supply	Size
R/LH64T.1212.6.10.IK	12	12	125	25	24.5	19	9.8	f ₁ +w+a ₁	1	G1/8	01
R/LH64T.1616.4.10.IK	16	16	125	25	24.5	21	13.8	f ₁ +w+a ₁	1	VDI	01
R/LH64T.1616.6.10.IK	16	16	125	25	24.5	21	13.8	f ₁ +w+a ₁	1	G1/8	01
R/LH64T.2020.4.10.IK	20	20	125	25	24.5	25	17.8	f ₁ +w+a ₁	1	VDI	01
R/LH64T.2020.6.10.IK	20	20	125	25	24.5	25	17.8	f ₁ +w+a ₁	1	G1/8	01
R/LH64T.2525.4.10.IK	25	25	125	25	24.5	30	22.8	f ₁ +w+a ₁	1	VDI	01
R/LH64T.2525.6.10.IK	25	25	125	25	24.5	25	22.8	f ₁ +w+a ₁	1	G1/8	01
R/LH64T.1212.6.20.IK	12	12	125	25	24.5	19	9.3	f ₁ +w+a ₁	1	G1/8	02
R/LH64T.1616.4.20.IK	16	16	125	25	24.5	21	13.3	f ₁ +w+a ₁	1	VDI	02
R/LH64T.1616.6.20.IK	16	16	125	25	24.5	21	13.3	f ₁ +w+a ₁	1	G1/8	02
R/LH64T.2020.4.20.IK	20	20	125	25	24.5	25	17.3	f ₁ +w+a ₁	1	VDI	02
R/LH64T.2020.6.20.IK	20	20	125	25	24.5	25	17.3	f ₁ +w+a ₁	1	G1/8	02
R/LH64T.2525.4.20.IK	25	25	125	25	24.5	30	22.3	f ₁ +w+a ₁	1	VDI	02
R/LH64T.2525.6.20.IK	25	25	125	25	24.5	25	22.3	f ₁ +w+a ₁	1	G1/8	02

State R or L version

w see indexable inserts

Dimensions in mm

For torque specification of the screw, please see Technical Instructions.

Spare Parts

Toolholder	Coolant Supply	Clamping Screw	TORX PLUS® Wrench	O-ring	Sealing plug	Threaded Pin
R/LH64T.1212.6...	004.00.61	030.4010 T15P	T15PQ			
R/LH64T...4		030.4010 T15P	T15PQ	12.37.2.62.3601		
R/LH64T...IK	004.00.16	030.4010 T15P	T15PQ		004.00.26	18.05.913

Toolholder

H64T

Depth of groove up to

5.5 mm

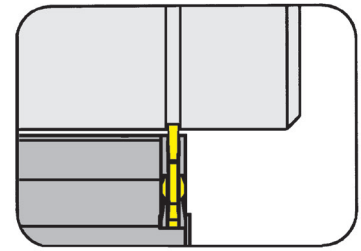

for Indexable insert

Type S64T

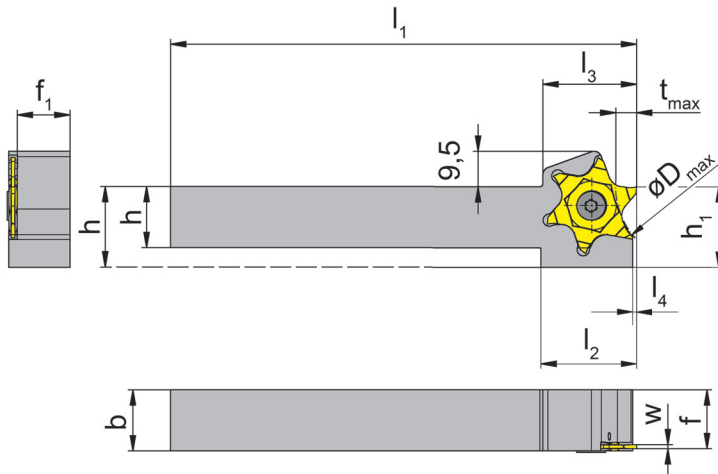

Grooving and Parting off

D _{max}	t _{max}
40	5.5
45	5.5
50	4.5
55	4.0
65	3.5
70	3.5
80	3.5
100	2.5

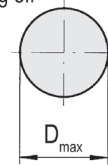

L = left hand version shown

R = right hand version

Part number	h	b	l ₁	l ₂	l ₃	h ₁	f ₁	f	l ₄	Size
R/LH64T.1212.10	12	12	125	25	25.4	19	9.8	f ₁ +w+a ₁	1	01
R/LH64T.1616.10	16	16	125	25	25.4	21	13.8	f ₁ +w+a ₁	1	01
R/LH64T.2020.10	20	20	125	25	25.4	25	17.8	f ₁ +w+a ₁	1	01
R/LH64T.2525.10	25	25	125	-	25.4	25	22.8	f ₁ +w+a ₁	1	01
R/LH64T.1212.20	12	12	125	25	25.4	19	9.3	f ₁ +w+a ₁	1	02
R/LH64T.1616.20	16	16	125	25	25.4	21	13.3	f ₁ +w+a ₁	1	02
R/LH64T.2020.20	20	20	125	25	25.4	25	17.3	f ₁ +w+a ₁	1	02
R/LH64T.2525.20	25	25	125	-	25.4	25	22.3	f ₁ +w+a ₁	1	02

State R or L version

w see indexable inserts

Dimensions in mm

For torque specification of the screw, please see Technical Instructions.

Spare Parts

Toolholder	Clamping Screw	TORX PLUS® Wrench
R/LH64T...	030.4010 T15P	T15PQ

R4

Call Us Toll Free (888) 818-4676

Indexable insert

S64T

Width of groove	.039 - .059"
-----------------	--------------

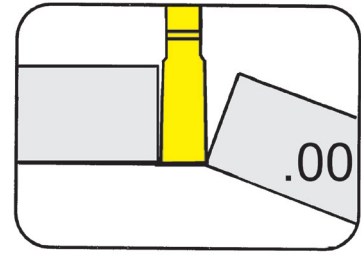

for Toolholder

Type H64T

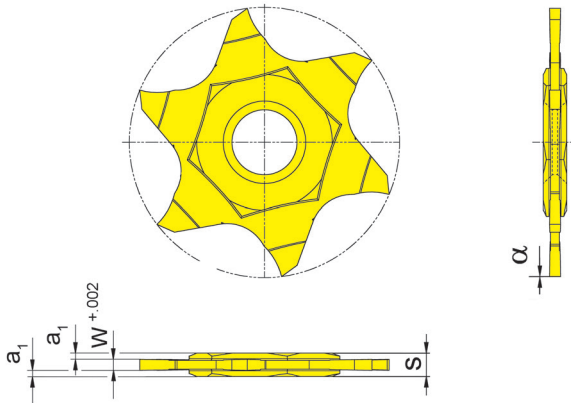

Part number	w	a ₁	s	α	Size	EG55
S64T.0010.00	.039	.023	.087	0°	01	▲
S64T.0015.00	.059	.013	.087	0°	01	▲

▲ on stock Δ 4 weeks x upon request

- recommended
- alternative recommendation
- not suitable

- uncoated grades
- coated grades
- brazed/Cermet

Dimensions in inch

P	●
M	○
K	○
N	-
S	-
H	-

Carbide grades

Indexable inserts can be used in right and left hand toolholders.

Indexable insert

S64T

Circlip grooves
Width of circlip Nw

DIN471/472
.013 - .124"

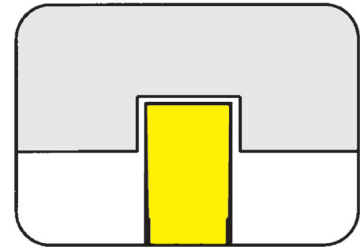

for Toolholder

Type H64T

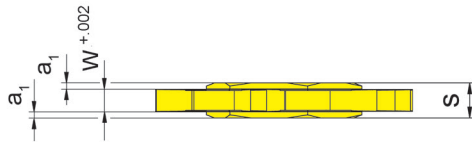
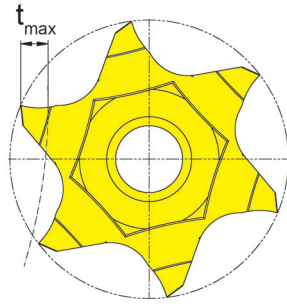

R

Part number	w	Nw	t _{max}	a ₁	s	Size	EG35	EG55
S64T.0034.00	.015	.013	.024	.036	.087	01	Δ	
S64T.0044.00	.019	.017	.028	.034	.087	01	Δ	
S64T.0050.00	.022	.020	.028	.033	.087	01		▲
S64T.0060.00	.026	.024	.031	.031	.087	01		▲
S64T.0070.00	.030	.028	.043	.029	.087	01		▲
S64T.0080.00	.034	.031	.047	.027	.087	01		▲
S64T.0090.00	.038	.035	.055	.025	.087	01		▲
S64T.0100.00	.042	.039	.063	.023	.087	01		▲
S64T.0110.00	.049	.043	.063	.019	.087	01		▲
S64T.0130.00	.057	.051	.079	.015	.087	01		▲
S64T.0160.00	.069	.063	.138	.009	.087	01		▲
S64T.0185.00	.078	.073	.138	.005	.087	01		▲
S64T.0215.00	.090	.085	.138	.003	.094	01		▲
S64T.0265.00	.110	.104	.138	.003	.114	02		▲
S64T.0315.00	.130	.124	.138	.003	.134	02		▲

- ▲ on stock Δ 4 weeks x upon request
- recommended
- alternative recommendation
- not suitable
- uncoated grades
- coated grades
- brazed/Cermet

Dimensions in inch

	P	M	K	N	S	H
EG35	●	●	○	-	-	-
EG55	●	○	○	-	-	-

Carbide grades

Indexable inserts can be used in right and left hand toolholders.

Indexable insert

S64T

Full radius	.020 - .059"
-------------	--------------

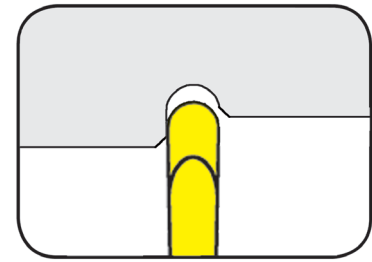

for Toolholder

Type H64T

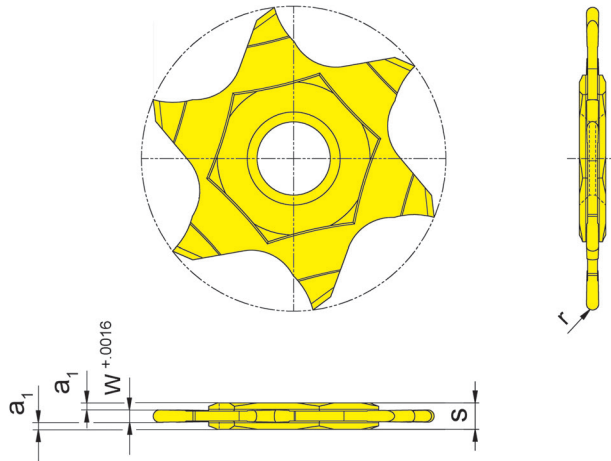

Part number	w	a ₁	r	s	Size	EG55
S64T.0100.05	.039	.023	.020	.087	01	▲
S64T.0120.06	.047	.019	.024	.087	01	▲
S64T.0160.08	.063	.011	.031	.087	01	▲
S64T.0200.10	.079	.004	.039	.087	01	▲
S64T.0250.12	.098	.004	.049	.106	02	▲
S64T.0300.15	.118	.004	.059	.126	02	▲

▲ on stock Δ 4 weeks x upon request

- recommended
- alternative recommendation
- not suitable

- uncoated grades
- coated grades
- brazed/Cermet

Dimensions in inch

P	●
M	○
K	○
N	-
S	-
H	-

Carbide grades

Indexable inserts can be used in right and left hand toolholders.



Indexable insert

S64T

Width of groove .059 - .118"

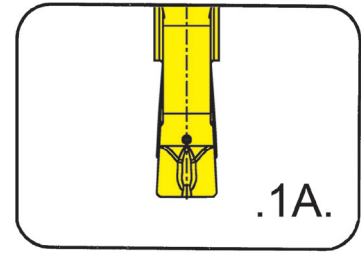

for Toolholder

Type H64T

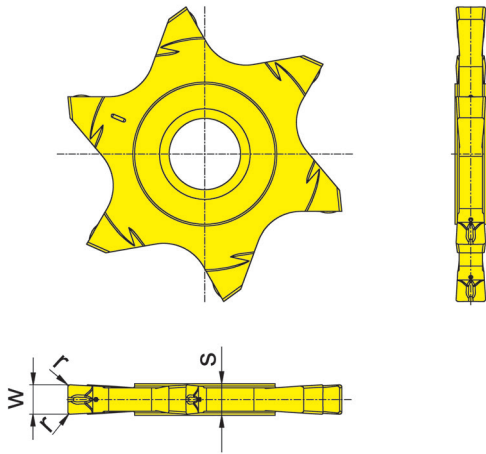

R

Part number	w	r	s	Size	Carbide grades	
					EG55	IG35
S64T.0150.1A2	.059	.008	.087	01	▲	▲
S64T.0200.1A2	.079	.008	.087	01	▲	▲
S64T.0250.1A2	.098	.008	.106	02	▲	▲
S64T.0300.1A2	.118	.008	.126	02	▲	▲

▲ on stock Δ 4 weeks x upon request

- recommended
- alternative recommendation
- not suitable

- uncoated grades
- coated grades
- brazed/Cermet

Dimensions in inch

	EG55	IG35
P	●	-
M	○	●
K	○	-
N	-	-
S	-	●
H	-	-

Carbide grades

Indexable inserts can be used in right and left hand toolholders.

Indexable insert

S64T

Width of groove .059 - .118"

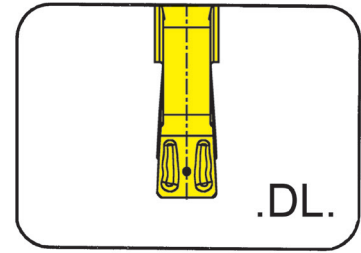

for Toolholder

Type H64T

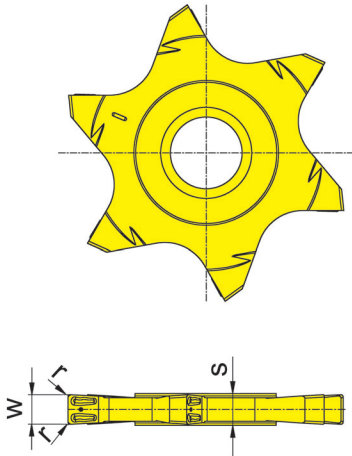

Part number	w	r	s	Size	EG55
S64T.0150.DL2	.059	.008	.087	01	▲
S64T.0150.DL4	.059	.016	.087	01	▲
S64T.0200.DL2	.079	.008	.087	01	▲
S64T.0200.DL4	.079	.016	.087	01	▲
S64T.0250.DL2	.098	.008	.106	02	▲
S64T.0250.DL4	.098	.016	.106	02	▲
S64T.0300.DL2	.118	.008	.126	02	▲
S64T.0300.DL4	.118	.016	.126	02	▲

- ▲ on stock Δ 4 weeks x upon request
- recommended
- o alternative recommendation
- not suitable
- uncoated grades
- coated grades
- brazed/Cermet

P	●
M	o
K	o
N	-
S	-
H	-

Carbide grades

Dimensions in inch

Indexable inserts can be used in right and left hand toolholders.

Indexable insert

S64T

Width of groove	.039 - .059"
-----------------	--------------

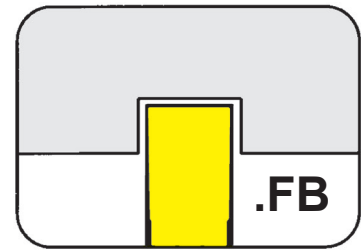

for Toolholder

Type H64T

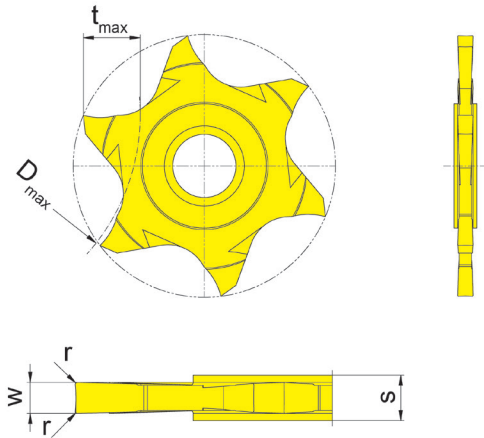

R

Part number	w	r	s	Size	EG35
S64T.FB10.01	.039	.004	.087	01	▲
S64T.FB15.01	.059	.004	.087	01	▲

▲ on stock Δ 4 weeks x upon request

- recommended
- alternative recommendation
- not suitable

□ uncoated grades

■ coated grades

■ brazed/Cermet

Dimensions in inch

P	●
M	○
K	○
N	-
S	-
H	-

Carbide grades

Indexable inserts can be used in right and left hand toolholders.

Threading (external) Full profile



Indexable insert

S64T

Pitch	1.00 - 2.00 mm
-------	----------------

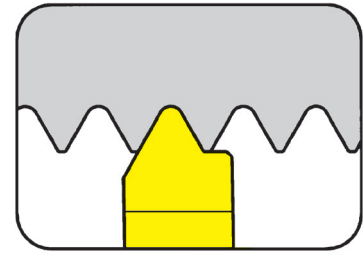

for Cassette and toolholder

Type NK64T
S64T

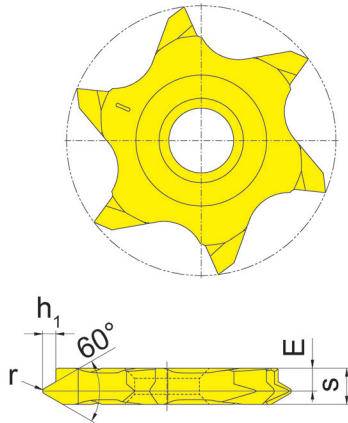

Part number	P mm	E	r	h ₁	s	Size	EG55
R/LS64T.0610.02	1.00	.098	.006	.024	.134	02	▲/△
R/LS64T.0712.02	1.25	.098	.007	.031	.134	02	▲/△
R/LS64T.0915.02	1.50	.087	.008	.037	.134	02	▲/△
R/LS64T.1017.02	1.75	.087	.010	.043	.134	02	▲/△
R/LS64T.1220.02	2.00	.085	.011	.049	.134	02	▲/△

▲ on stock Δ 4 weeks x upon request

- recommended
- alternative recommendation
- not suitable

- uncoated grades
- coated grades
- brazed/Cermet

Dimensions in inch

State R or L version

P	●
M	○
K	○
N	-
S	-
H	-

Carbide grades

Threading (external) Full profile



Indexable insert

S64T

Threads per inch	11 - 28
------------------	---------

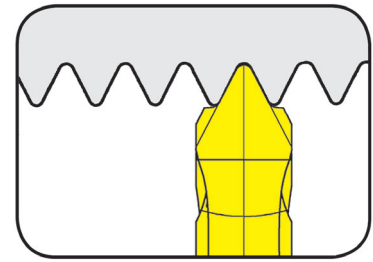

for Cassette and toolholder

Type H64T
NK64T

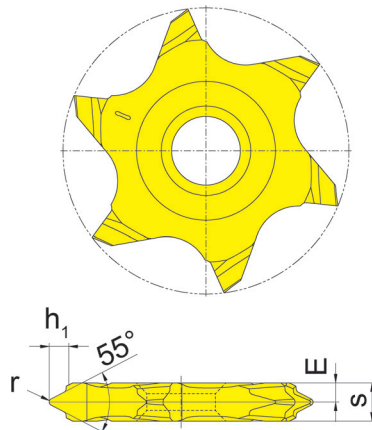

R

Part number	TPI	E	r	h ₁	s	Size	EG55
R/LS64T.5519.02	19	.079	.007	.034	.134	02	ΔΔ
R/LS64T.5528.02	28	.091	.004	.024	.134	02	ΔΔ
NS64T.5511.02	11	.067	.012	.059	.134	02	Δ
NS64T.5514.02	14	.067	.009	.046	.134	02	Δ

▲ on stock Δ 4 weeks x upon request

- recommended
- alternative recommendation
- not suitable

- uncoated grades
- coated grades
- brazed/Cermet

Dimensions in inch

State R or L version

P	●
M	○
K	○
N	-
S	-
H	-

Carbide grades



S

Tools for Swiss Type Machines

Toolholder
B105/BU105

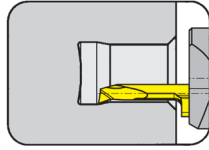

Page
S4-S5, S12-S13

Adjustable holder
BKT

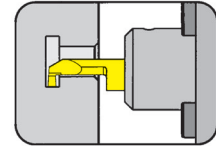

Page
S17-S18, S20

Toolholder
H105

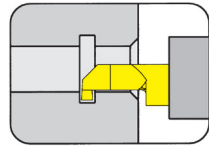

Page
S6, S14

Adjustable holder
BGT

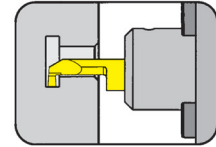

Page
S16, S19, S20

Toolholder
HC105

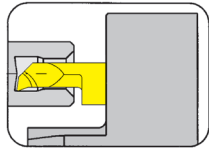

Page
S7-S8

Basic toolholder Graf
Z

GRAF
WERNER TREIBSYSTEME

Page
S21

Basic toolholder
HC105/760

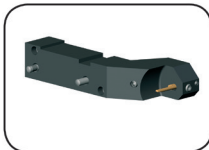

Page
S9

Graf Adaptor
G

GRAF
WERNER TREIBSYSTEME

Page
S22-S23

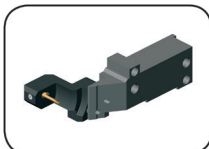

Page
S10

Graf Adaptor
N

GRAF
WERNER TREIBSYSTEME

Page
S22-S31

Toolholder
VDI

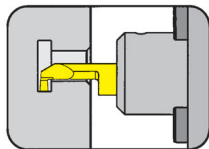

Page
S11

Toolholder
BU108/B108

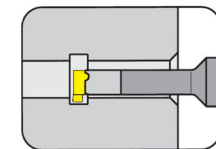

Page
S32-S33

Toolholder
B105

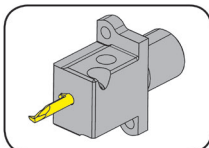

Page
S15

Toolholder
BU111/B111

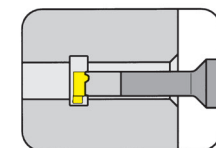

Page
S34-S35

S

Toolholder
H100

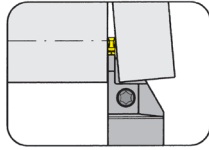

Page
S36

Cartridge
369

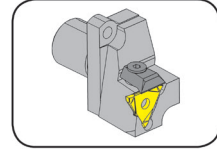

Page
S53

Toolholder
H264

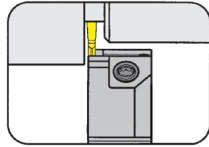

Page
S37-S40

Toolholder
U248/248

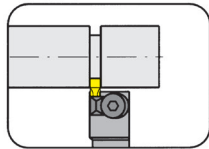

Page
S41-42

Cartridge
KT274/KTC274

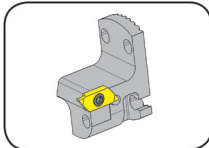

Page
S43-S45

Toolholder
H224

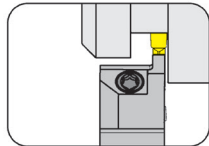

Page
S46-S47

Cassette
368

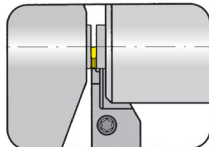

Page
S48-S50, S52

Toolholder
361

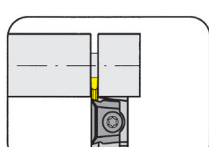

Page
S48-S50, S52

S

Toolholder

BU105

with through coolant supply

Bore \varnothing from
Depth of groove
Width of groove up to

0.2 mm
2.5 mm
2 mm

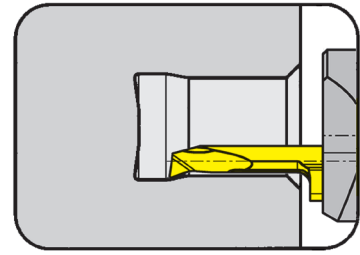

For Insert

Type 105

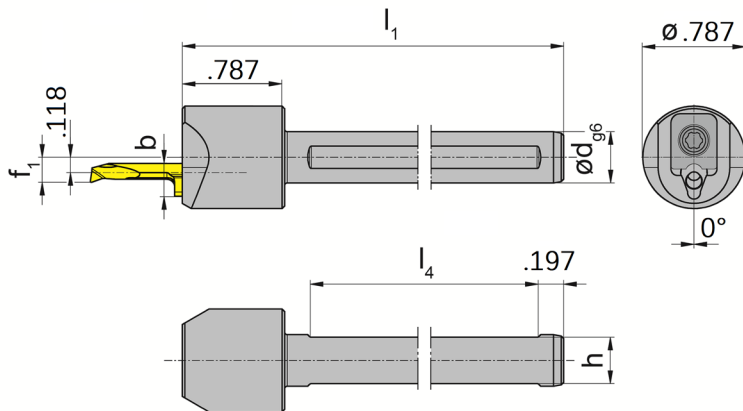

Face clamped insert!

Picture = right hand cutting version

Part number	d	l_1	h	l_4	f_1	b
BU105.0750.S.03	.750	3.543	.671	2.165	.169	.232
BU105.0750.S.04	.750	3.543	.671	2.165	.193	.252
BU105.0750.S.05	.750	3.543	.671	2.165	.248	.276
BU105.1000.S.03	1.000	3.543	.921	2.165	.169	.232
BU105.1000.S.04	1.000	3.543	.921	2.165	.252	.252
BU105.1000.S.05	1.000	3.543	.921	2.165	.248	.276

Further sizes upon request

b = Height of insert

Dimensions in inch

Ordering note:

Toolholders can be used with right and left hand inserts.

Spare Parts

Toolholder	Clamping element	Screw	Md	b	TORX PLUS® Wrench
BU105...03	010.0105.03	030.000.1157	2 Nm	.232	T15PL
BU105...04	010.0105.04	030.000.1157	2 Nm	.252	T15PL
BU105...05	010.0105.05	030.000.1157	2 Nm	.276	T15PL

Toolholder

B105

with through coolant supply

Bore Ø from
Depth of groove
Width of groove up to

0.2 mm
2.5 mm
2 mm

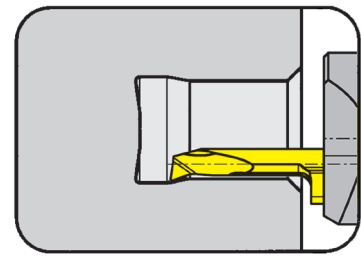

For Insert

Type 105

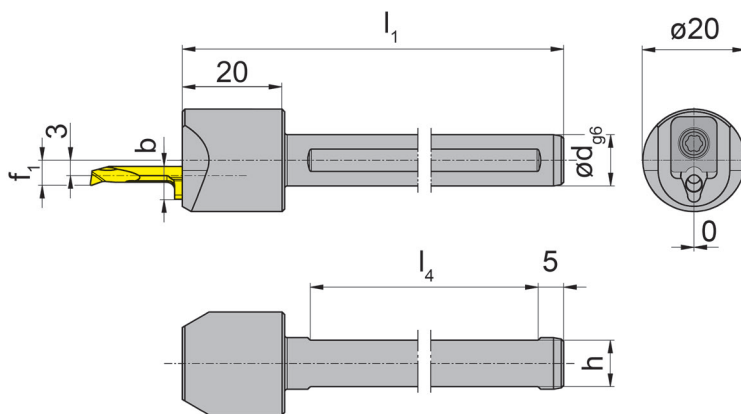

Picture = right hand cutting version

Face clamped insert!

Part number	d	l ₁	h	l ₄	f ₁	b
B105.0010.S.03	10	80	9	50	4.3	5.9
B105.0012.S.03	12	80	11	50	4.3	5.9
B105.0016.S.03	16	80	14	50	4.3	5.9
B105.0020.S.03	20	90	18	55	4.3	5.9
B105.0025.S.03	25	100	23	55	4.3	5.9
B105.0028.S.03	28	120	26	55	4.3	5.9
B105.0010.S.04	10	80	9	50	4.9	6.4
B105.0012.S.04	12	80	11	50	4.9	6.4
B105.0016.S.04	16	80	14	50	4.9	6.4
B105.0020.S.04	20	90	18	55	4.9	6.4
B105.0025.S.04	25	100	23	55	4.9	6.4
B105.0028.S.04	28	120	26	55	4.9	6.4
B105.0010.S.05	10	80	9	50	6.3	7.0
B105.0012.S.05	12	80	11	50	6.3	7.0
B105.0016.S.05	16	80	14	50	6.3	7.0
B105.0020.S.05	20	90	18	55	6.3	7.0
B105.0025.S.05	25	100	23	55	6.3	7.0
B105.0028.S.05	28	120	26	55	6.3	7.0

Further sizes upon request

b = Height of insert

Dimensions in mm

Ordering note:

Toolholders can be used with right and left hand inserts.

Spare Parts

Toolholder	Clamping element	Screw	Md	b	TORX PLUS® Wrench
B105...03	010.0105.03	030.000.1157	2 Nm	5.9	T15PL
B105...04	010.0105.04	030.000.1157	2 Nm	6.4	T15PL
B105...05	010.0105.05	030.000.1157	2 Nm	7.0	T15PL

Toolholder

H105

with screwed clamping

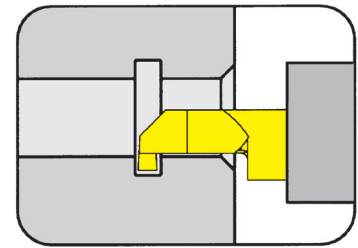

Bore Ø from 0.2 mm

For Insert

Type 105

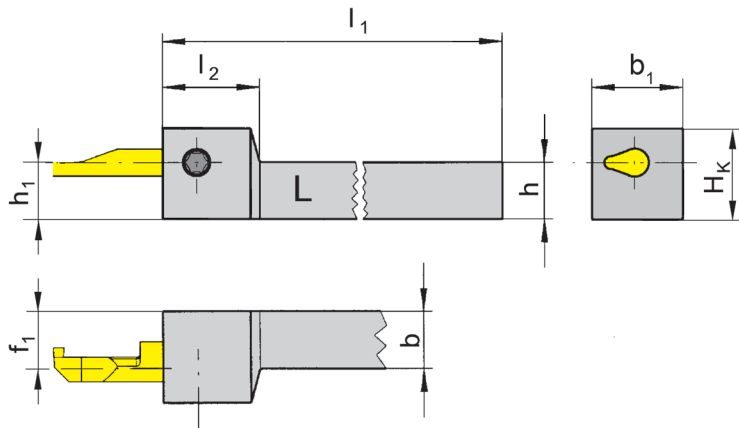

L = left hand version shown

R = right hand version

Part number	h	b	l_1	h_1	b_1	f_1	H_k	l_2
R/LH105.0808.01	8	8	90	8	16	7.5	14	17
R/LH105.1010.01	10	10	90	10	16	7.5	16	17
R/LH105.1212.01	12	12	90	12	16	7.5	18	17
R/LH105.1616.01	16	16	110	16	16	7.5	22	17

State R or L version

Dimensions in mm

Further sizes upon request

For torque specification of the screw, please see Technical Instructions.

Spare Parts

Toolholder	Clamping Screw	TORX PLUS® Wrench
R/LH105...	6.075T15P	T15PQ

Toolholder

HC105

with screwed clamping

Bore Ø from

0.2 mm

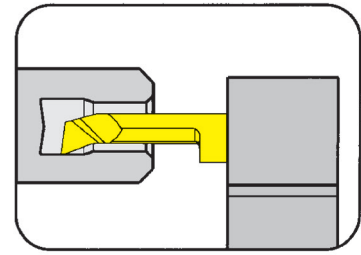

For Insert

Type 105

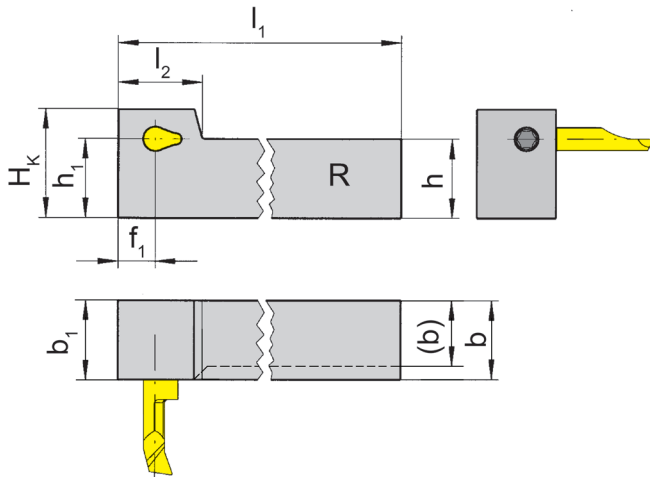

R = right hand version shown

L = left hand version

Part number	h	b	l_1	l_2	h_1	b_1	f_1	H_k
R/LHC105.1212.01	12	12	90	17	12	16	7.5	18
R/LHC105.1616.01	16	16	130	17	16	16	7.5	22

State R or L version

Dimensions in mm

Further sizes upon request

For torque specification of the screw, please see Technical Instructions.

Spare Parts

Toolholder	Clamping Screw	TORX PLUS® Wrench
R/LHC105...	6.075T15P	T15PQ

Toolholder

HC105

with screwed clamping

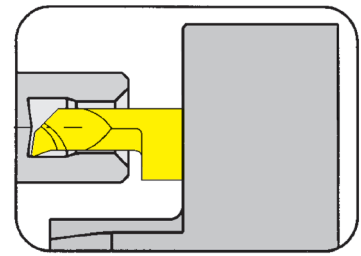

Bore Ø from 0.2 mm

For Insert

Type 105

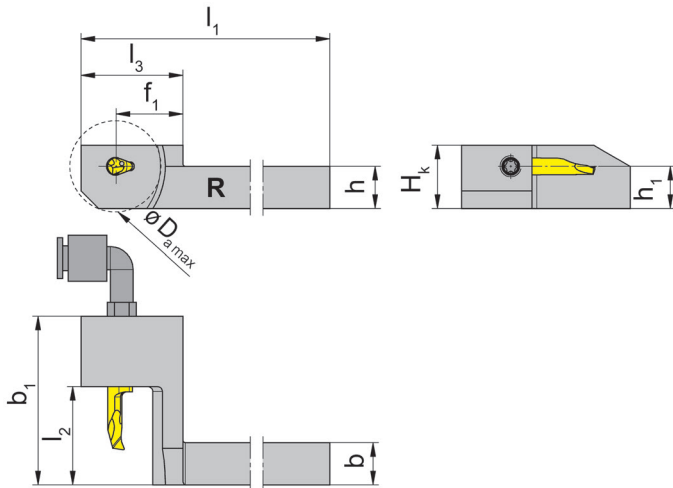

R = right hand version shown

L = left hand version

Coolant supply through cranked fitting

Part number	h	b	l ₁	l ₃	h ₁	b ₁	f ₁	D _{a max}	H _K	l ₂
R/LHC105.0707.21*	7	7	99	29	7	32.0	19	26	13	18
R/LHC105.0808.21*	8	8	99	29	8	32.0	19	26	13	18
RHC105.1010.11*	10	10	99	29	10	22.7	19	26	16	8
R/LHC105.1010.21	10	10	99	29	10	38.0	19	26	16	18
R/LHC105.1010.41	10	10	99	29	10	48.0	19	26	16	28
R/LHC105.1212.21	12	12	99	29	12	38.0	19	26	18	18
R/LHC105.1212.41	12	12	99	29	12	48.0	19	26	18	28
R/LHC105.1616.21	16	16	104	34	16	38.0	24	36	22	18
R/LHC105.1616.41	16	16	104	34	16	48.0	24	36	22	28

State R or L version

Dimensions in mm

Further sizes upon request

Note:

* = no through coolant supply!

For torque specification of the screw, please see Technical Instructions.

Spare Parts

Toolholder	Clamping Screw	TORX PLUS® Wrench	SMC angled screw coupling
R/LHC105...11*/.21*	6.075T15P	T15PQ	
R/LHC105...	6.075T15P	T15PQ	KQ2L06-M5

Basic toolholder

HC105

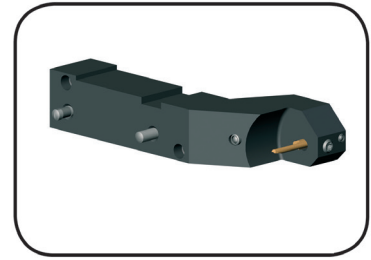

Bore Ø from 0.2 mm

Tool for Tornos

For Insert

Type 105

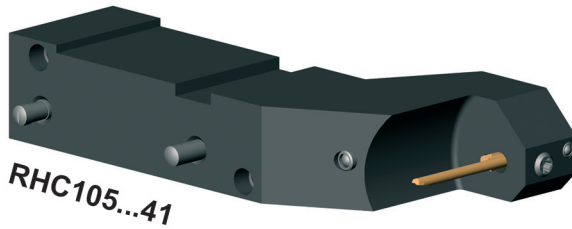
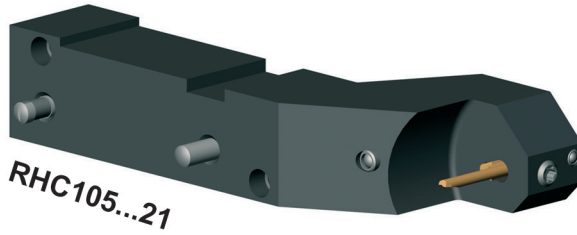

Part number	Machine type	Insert
RHC105.0710.21	EvoDECO 10	105...21 l ₂ up to 15 mm
RHC105.0710.41	EvoDECO 10	105...41 l ₂ up to 25 mm

Further sizes upon request

Dimensions in mm

For torque specification of the screw, please see Technical Instructions.

Spare Parts

Basic toolholder	Clamping Screw	SMC angled screw coupling	TORX PLUS® Wrench	Straight pin
RHC105...	6.075T15P	KQ2L06-M5	T15PQ	020.0518.1610



Basic toolholder

760

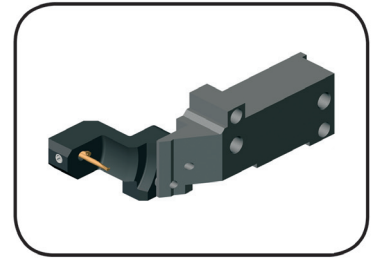

Depth of groove up to 0.2 mm

Tool for Tornos

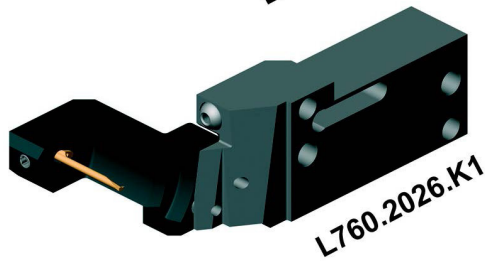
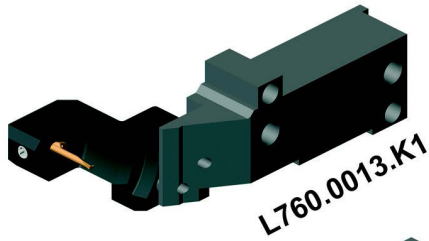

S

Part number	Machine type	Cassette	Insert
L760.0013.K1	EvoDECO 16	RKC760.0105.21	105...21 l ₂ up to 15 mm
L760.2026.K1	EvoDECO 20/EvoDECO 32	RKC760.0105.41	105...41 l ₂ up to 25 mm

Further sizes upon request

Dimensions in mm

Spare Parts

Basic toolholder	Allen wrench
L760...	SW5,0 DIN911

Toolholder

VDI

with through coolant supply

Bore \varnothing from 0.2 mm

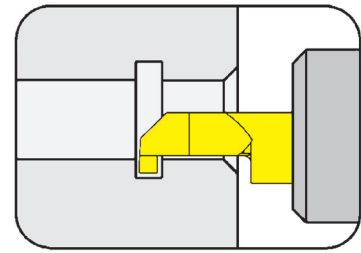

For Insert

Type 105

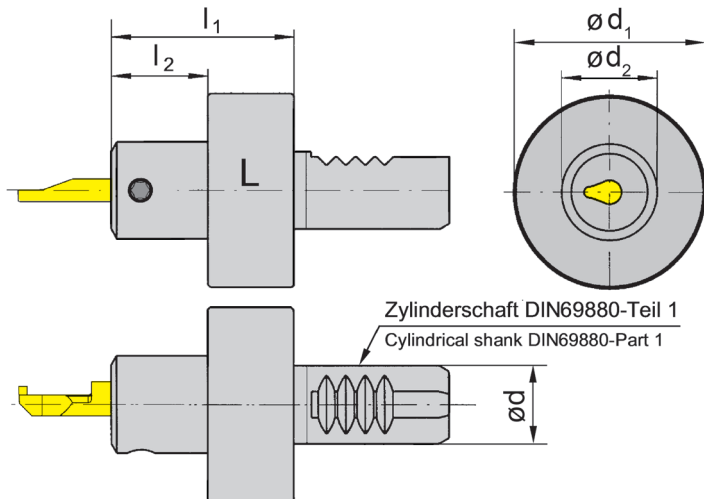

L = left hand version shown

R = right hand version

Part number	d	l_1	l_2	d_2	d_1
VDI16.L105.20.01	16	38	20	20	40
VDI16.R105.20.01	16	38	20	20	40
VDI20.L105.20.01	20	38	20	20	50
VDI20.R105.20.01	20	38	20	20	50
VDI25.L105.20.01	25	38	20	20	58
VDI25.R105.20.01	25	38	20	20	58
VDI30.L105.20.01	30	38	20	20	68
VDI30.R105.20.01	30	38	20	20	68
VDI40.L105.20.01	40	38	20	20	83
VDI40.R105.20.01	40	38	20	20	83

State R or L version

Dimensions in mm

Further sizes upon request

For torque specification of the screw, please see Technical Instructions.

Spare Parts

Toolholder	Clamping Screw	TORX PLUS® Wrench
VDI16...	6.075T15P	T15PQ

Toolholder

BU105

with through coolant supply

Bore Ø from	.197"
Depth of groove	.236"
Width of groove	.125"

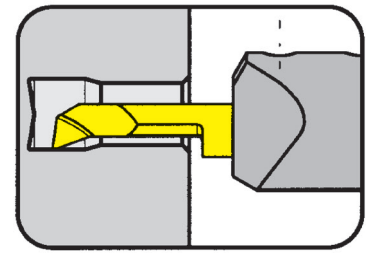

for Insert

Type 105

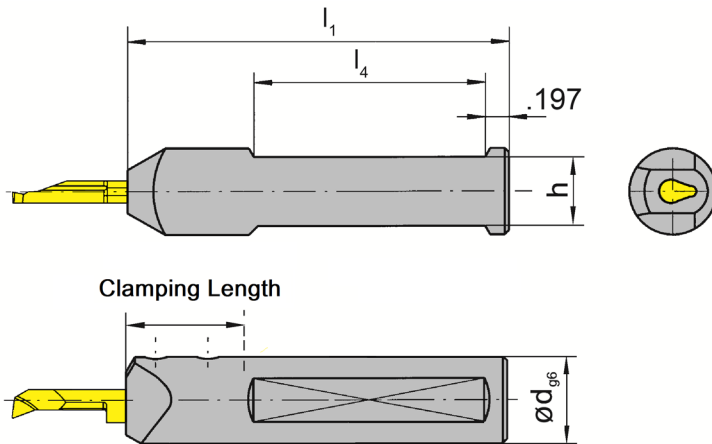

Picture = left hand cutting version

Part number	d	l ₁	h	l ₄	Clamping length
BU105.0625.01	.625	2.953	.546	1.969	.472
BU105.0750.01	.750	3.543	.671	2.756	.472
BU105.1000.01	1.000	3.543	.921	2.559	.472
BU105.0750.2.2.01	.750	4.724	.671	-	.472
BU105.0500.02	.500	3.346	.433	1.969	.866
BU105.0625.02	.625	3.346	.546	1.969	.866
BU105.0750.02	.750	3.937	.671	2.165	.866

Further sizes upon request

Dimensions in inch

Ordering note:

Toolholders can be used with right and left hand inserts.

For torque specification of the screw, please see Technical Instructions.

Spare Parts

Toolholder	Clamping Screw	TORX PLUS® Wrench
BU105...	6.075T15P	T15PQ

Toolholder

B105

with through coolant supply

Bore Ø from

<3 / >5 mm

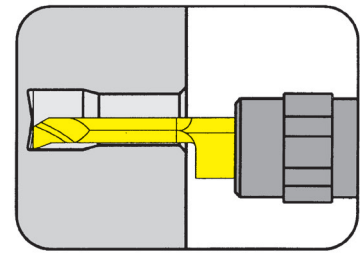

For Insert

Type 105.0010... $\varnothing \leq 3$
 105.0012... $\varnothing \geq 5$
 105.0016... $\varnothing \geq 5$

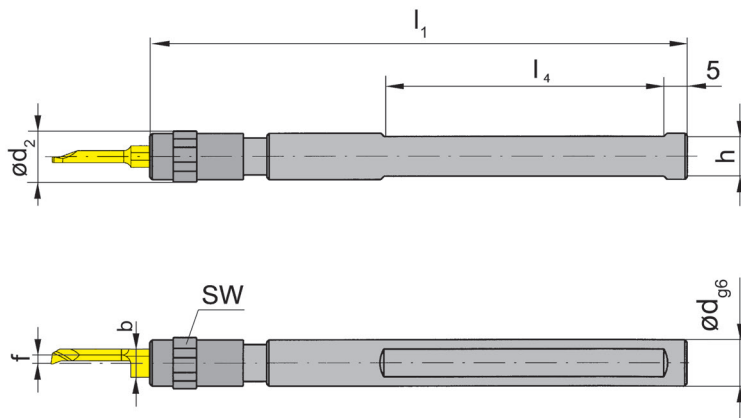

Picture = right hand cutting version

Part number	d	l_1	h	l_4	f	d_2	SW	b
B105.0010.9.01	10	100	9	50	1.6	11	10	5.9
B105.0012.11.01	12	100	11	50	1.2	16	13	7.0
B105.0016.11.01	16	100	15	50	1.2	16	13	7.0

Further sizes upon request

b = Height of insert

Dimensions in mm

Ordering note:

Toolholders can be used with right and left hand inserts.

Spare Parts

Toolholder	Clamping nut
B105.0010.9.01	020.0010.1719
B105.00...	020.0016.1999

Toolholder

B105

with through coolant supply

Bore Ø from
Depth of groove
Width of groove

0.2 mm
2.5 mm
2 mm

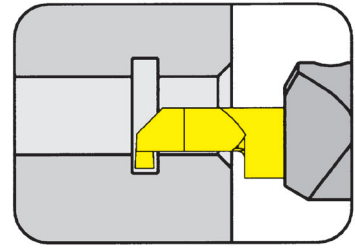

for Insert

Type 105

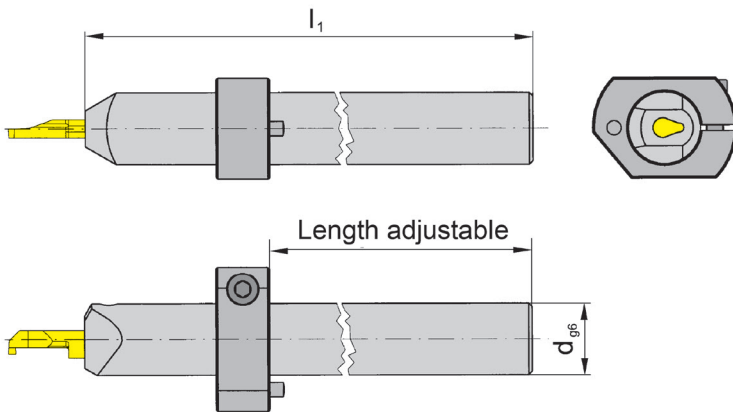

Picture = right hand cutting version

Part number	d	l ₁
B105.0020.2.01	20	150
B105.0025.2.01	25	150

Further sizes upon request

Dimensions in mm

Ordering note:

Toolholders can be used with right and left hand inserts.

Adjusting ring is not combined with the toolholder - separate order required!

For torque specification of the screw, please see Technical Instructions.

Adjustment ring	d	Type of machine
020.0020.1665	20	Tornos
020.0025.2234	25	Tornos

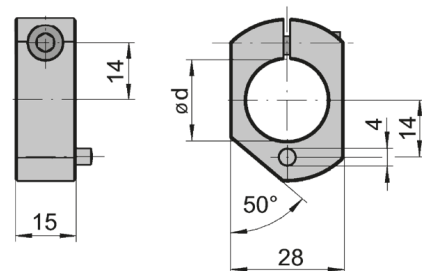

Spare Parts

Toolholder	Clamping Screw	SMC angled screw coupling	TORX PLUS® Wrench
B105...	6.075T15P	KQ2L06-M5	T15PQ

Toolholder

B105

with through coolant supply

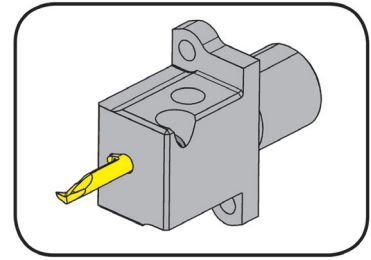

Bore Ø from
Depth of groove
Width of groove

0.2 mm
2.5 mm
2 mm

Through coolant supply G1/8" Hole pattern 13.7 x 37.6 mm

For Insert

Type 105

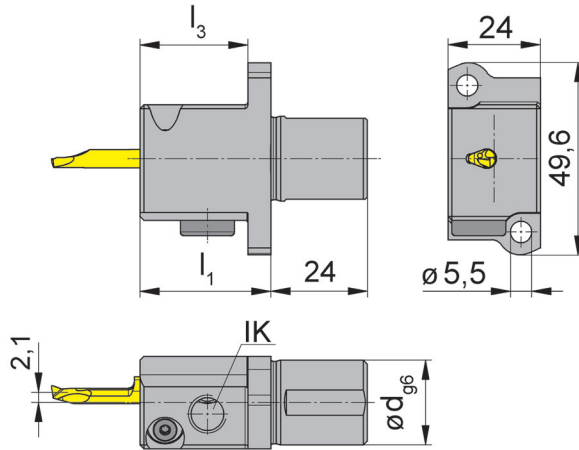

Picture = left hand cutting version

for Swiss type machines
Star

Part number	d	l ₁	l ₃
LB105.A022.26.31	22	35	29

Further sizes upon request

Dimensions in mm

For torque specification of the screw, please see Technical Instructions.

Swiss Type Machines Star: ECAS-12/20, SB16D/E, SR-20, SR20J/JN, RS-20RII, RS-20RIII, RS-20RIV, RS-32J/JN, SW-12RII

Spare Parts

Toolholder	Allen wrench	Clamping	TORX PLUS® Wrench	Screw Plug
LB105.A022.26.31	SW3,0 DIN911	070.0010.0118	T10PL	18.908

Basic toolholder

BGT

without cartridge

Adjustable round shanks for toolholder BKT105.2445.01/02

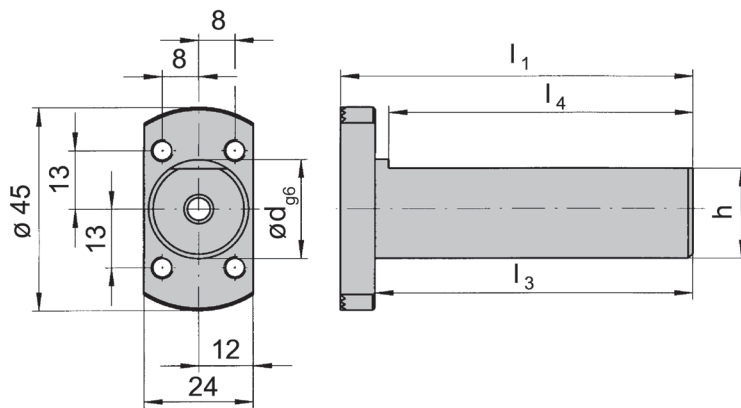
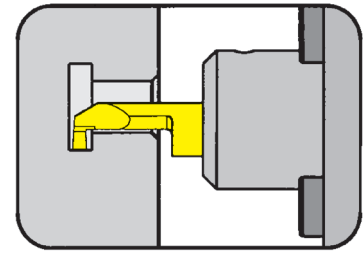

with through coolant supply

Part number	d	l ₁	h	l ₃	l ₄	Machine type
BGT001.0010.50	10	57.50	9	50	47	-
BGT001.0016.21	16	28.50	14	21	18	Star
BGT001.0R16.21	16	28.50	14	21	18	Star
BGT001.0020.100	20	107.50	18	100	97	Tornos
BGT001.0022.30	22	36.35	20	30	27	Star
BGT001.0022.70	22	77.50	20	70	67	Star
BGT001.0025.70	25	77.50	23	70	67	-
BGT001.0028.80	28	87.50	26	81	77	Traub

Further sizes upon request

Dimensions in mm

Note:

BGT001.0022.30 without through coolant supply

Spare Parts

Basic toolholder	Allen wrench	O-ring	Clamping Screw
BGT001...	SW4,0 DIN911	7.00.3.00.3601	5.10.912
BGT001.0022.30	SW4,0 DIN911		5.10.912

Adjustable holder

BKT

Bore \varnothing from
Depth of groove up to
Width of groove up to

0.2 mm
2.5 mm
2 mm

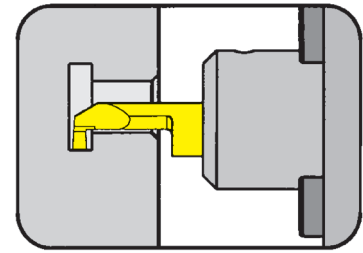

for Insert

Type 105

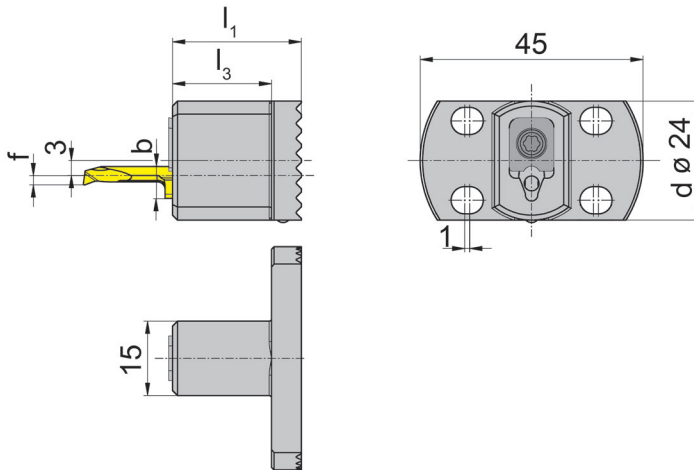

Part number	l_1	d	l_3	b
BKT105.2445.S.03	26	24	20	5.9
BKT105.2445.S.04	26	24	20	6.4
BKT105.2445.S.05	26	24	20	7.0

Further sizes upon request

f see inserts type 105

b = Height of insert

Dimensions in mm

Spare Parts

Toolholder	Clamping element	Screw	Md	b	TORX PLUS® Wrench
BKT105...03	010.0105.03	030.000.1157	2 Nm	5.9	T15PL
BKT105...04	010.0105.04	030.000.1157	2 Nm	6.4	T15PL
BKT105...05	010.0105.05	030.000.1157	2 Nm	7.0	T15PL

Adjustable holder

BKT

Bore \varnothing from
Depth of groove up to
Width of groove up to

0.2 mm
2.5 mm
2 mm

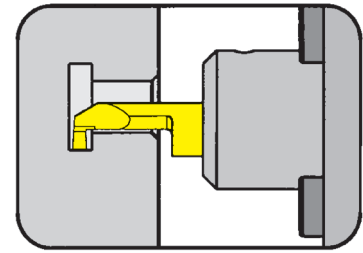

for Insert

Type 105

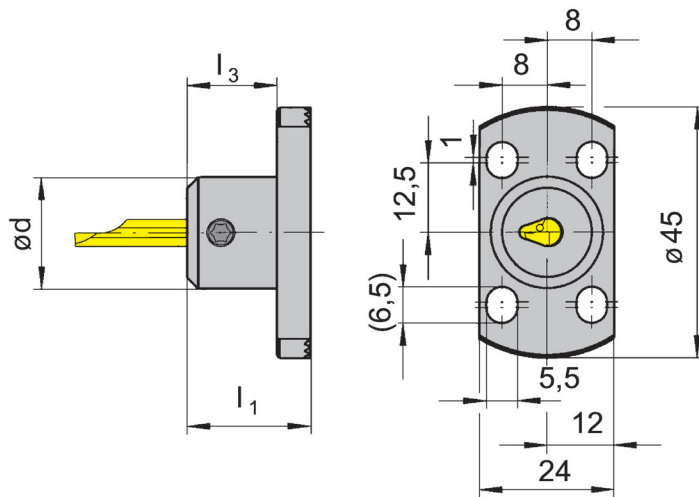

with through coolant supply

Part number	d	l_1	l_3
BKT105.2445.01	20	22	16
BKT105.2445.02	20	32	26

Further sizes upon request

Dimensions in mm

Note:

If using cartridge HORN type BKT with basic toolholder Graf G or adaptor Graf type N and Z, no through coolant supply will be possible.

For torque specification of the screw, please see Technical Instructions.

Spare Parts

Adjustable holder	Clamping Screw	TORX PLUS® Wrench
BKT105...	6.075T15P	T15PQ

Basic toolholder

BGT

without cartridge

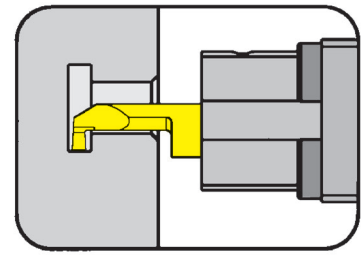

Adjustable round shanks for toolholder BKT105.2327.01

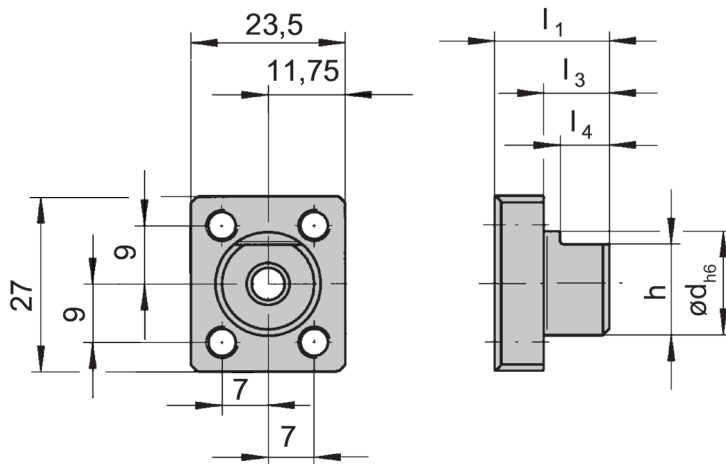

with through coolant supply

Part number	d	l_1	h	l_3	l_4	Machine type
BGT001.1627.10	16	17.5	14	10	7.5	Star

Further sizes upon request

Dimensions in mm

Spare Parts

Basic toolholder	Allen wrench	O-ring	Screw
BGT001.1627.10	SW4,0 DIN911	7.00.3.00.3601	5.10.912

Adjustable holder

BKT

Bore \varnothing from
Depth of groove up to
Width of groove up to

0.2 mm
2.5 mm
2 mm

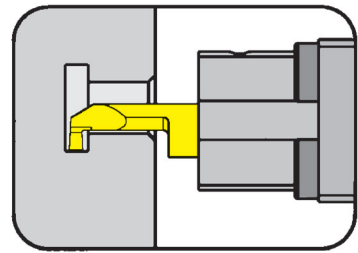

for Insert

Type 105

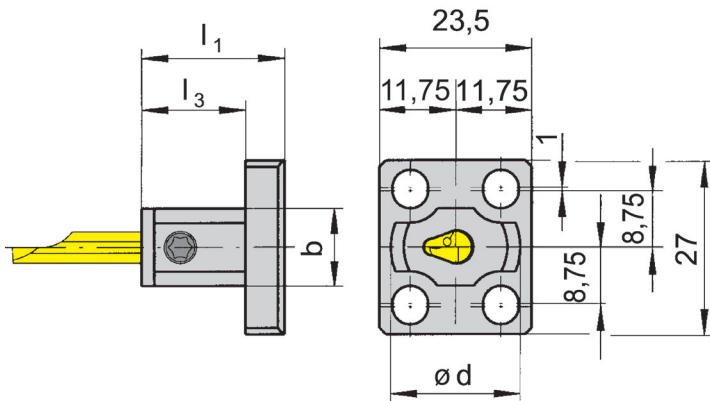

with through coolant supply

Part number	d	l_1	l_3	b
BKT105.2327.01	20	22	16	12

Further sizes upon request

Dimensions in mm

For torque specification of the screw, please see Technical Instructions.

Spare Parts

Adjustable holder	Clamping Screw	TORX PLUS® Wrench
BKT105.2327.01	6.075T15P	T15PQ

Basic toolholder

BGT

without cartridge

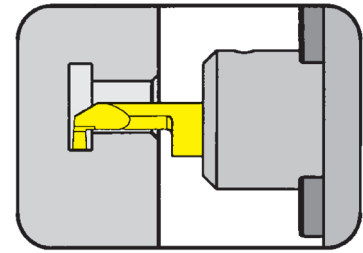

Adjustable round shanks for toolholder BKT105.2327.01

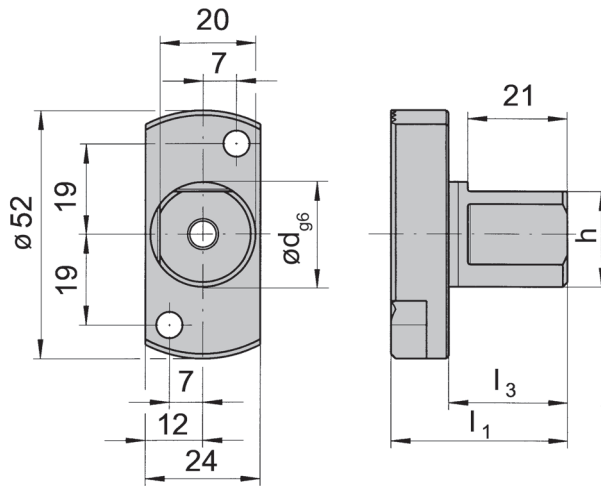

with through coolant supply

S

Part number	d	l_1	h	l_3	l_4
BGT001.0R22.25	22	37	20	25	21

Further sizes upon request

Dimensions in mm

Spare Parts

Basic toolholder	Allen wrench	Screw
BGT001.0R22.25	SW4,0 DIN911	5.10.912

Basic toolholder Graf

G

without cartridge



for adjustable holder Graf type N and HORN BKT105.2445.01/02

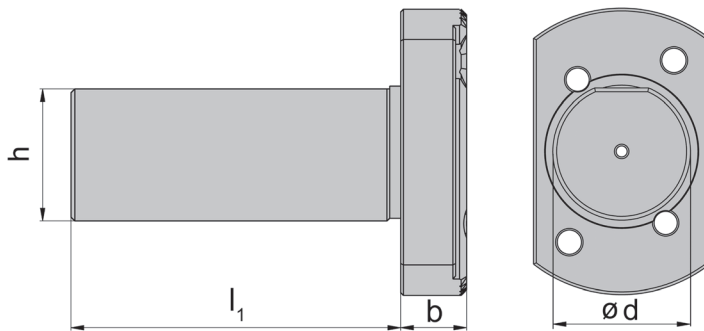

S

Part number	d	l ₁	h	b	Machine type
G.016.021	16.00	21	14	6	Star
G.016.040	16.00	40	14	6	Traub/Manurhin
G.034.040	3/4"	40	18	6	Citizen
G.034.050	3/4"	50	18	6	Citizen
G.034.120	3/4"	120	18	6	Citizen
G.020.030	20.00	30	18	6	Citizen
G.020.040	20.00	40	18	6	Hanwha
G.020.100	20.00	100	18	6	Tornos
G.020.150	20.00	150	18	6	Manurhin/Tornos
G.022.023	22.00	23	20	6	Star
G022025SR16/20R	22.00	25	20	12	Star
G.022.030	22.00	30	20	6	Star
G022030SR32	22.00	30	20	12	Star

Further sizes upon request

Dimensions in mm

Basic toolholder Graf

G

without cartridge



for adjustable holder Graf type N and HORN BKT105.2445.01/02

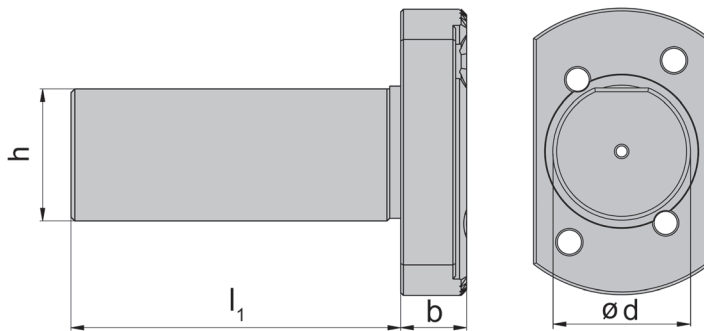

S

Part number	d	l ₁	h	b	Machine type
G.025.060	25	60	23	12	Hanwha
G.025.070	25	70	23	6	Manurhin/Tornos
G.025.100	25	100	23	6	Manurhin/Tornos
G.025.160	25	160	23	6	Manurhin/Tornos
G.010.060	1"	60	23	6	Citizen
G.010.100	1"	100	23	6	Citizen
G.028.006	28	6	26	12	Hanwha
G.028.080	28	80	26	12	Traub
G030045	30	45	27	12	Maier
G033040	33	40	31	12	Hanwha
G.034.020	34	20	32	12	Maier
G.034.044	34	44	32	12	Maier/Hanwha

Further sizes upon request

Dimensions in mm

Graf Adaptor

Z

without cartridge



for adjustable holder Graf type N and HORN BKT105.2445.01/02

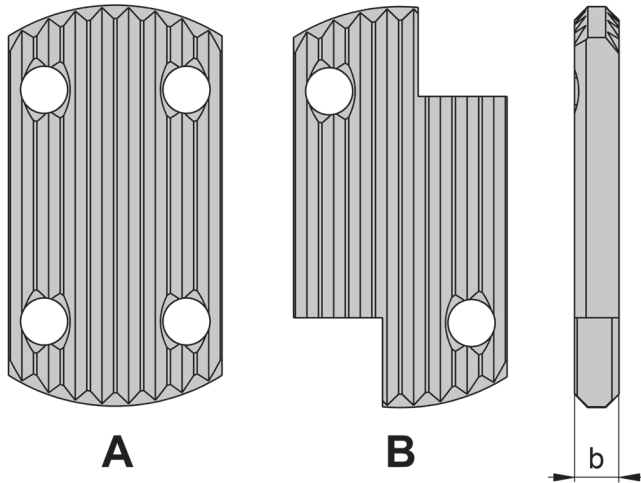

S

Part number	b	Form
Z.5	5	A
Z.10	10	A
Z.15	15	A
Z.20	20	A
Z.25	25	A
Z.30	30	A
Z5SR16/20R	5	B
Z10SR16/20R	10	B
Z15SR16/20R	15	B
Z20SR16/20R	20	B
Z25SR16/20R	25	B
Z30SR16/20R	30	B

Further sizes upon request

Dimensions in mm

Graf Adaptor

N

without cartridge



for adjustable holder Graf type N and HORN BKT105.2445.01/02

for back working

Part Number **N11**

2 Cartridges

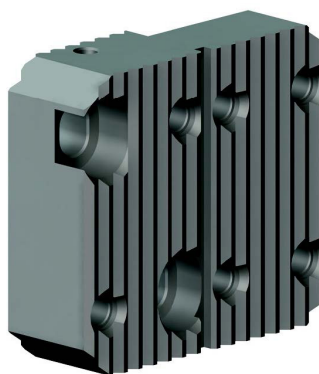

Part Number **N12**

3 Cartridges

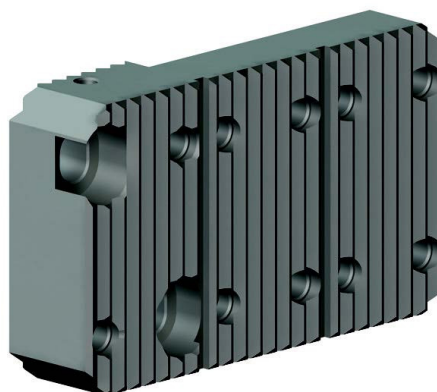

Part Number **N93IK**

With through coolant



S

Adjustable holder

N



Bore Ø from
Depth of groove up to
Width of groove up to

0.2 mm
2.5 mm
2 mm

for Insert

Type 105

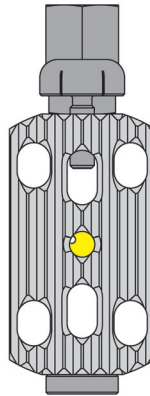
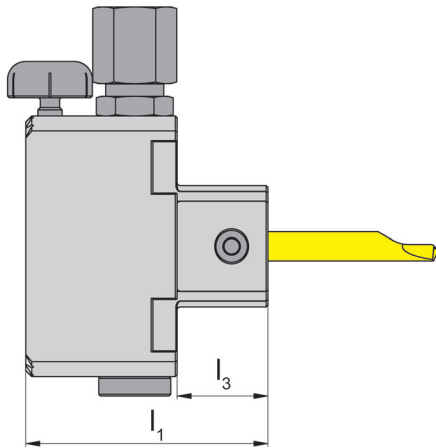

with through coolant supply

Part number	l_1	l_3
N.09.IK	40	15

Further sizes upon request

Dimensions in mm

Coolant tube is not included - separate order required!

Spare Parts

Adjustable holder	Clamping Screw	Screw to adjust the height	Coolant supply
N.09.IK	6.075T15P	002.00.69	004.00.19

Adjustable holder

N



Bore Ø from 0.2 mm
 Depth of groove up to 2.5 mm
 Width of groove up to 2 mm

for Insert

Type 105

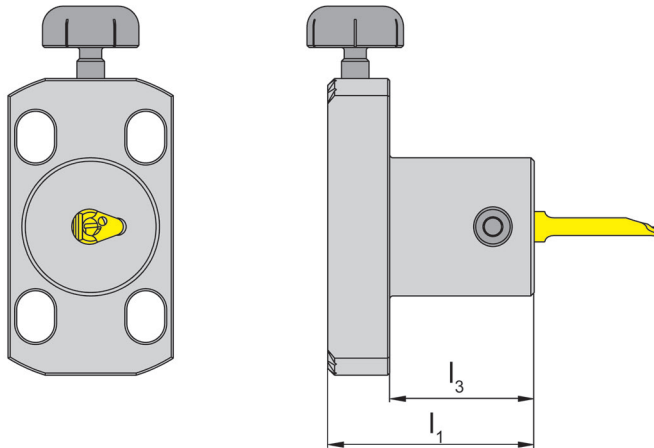

with through coolant supply

Part number	l_1	l_3
N.09	30	20

Further sizes upon request

Dimensions in mm

Spare Parts

Adjustable holder	Clamping Screw	Screw to adjust the height
N.09	6.075T15P	002.00.69

Adjustable holder

N



with chucking nut ER16 / ER20 system Graf

for Basic Holder

Type Horn BGT
Graf G

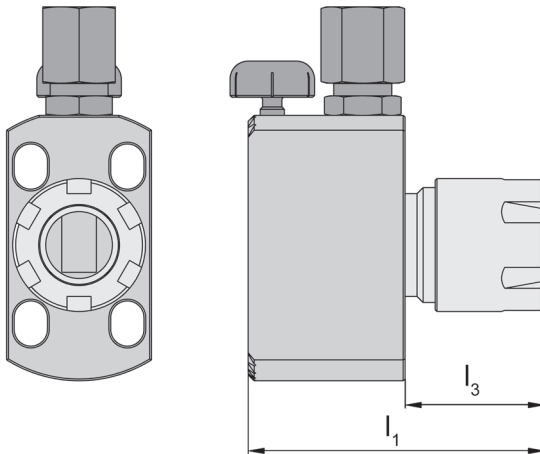

with through coolant supply

Part number	l_1	l_3	Clamping nut
N.07.IK	54	18	ER16
N.41.IK	64	26	ER20

Further sizes upon request

Dimensions in mm

Coolant tube is not included - separate order required!

Spare Parts

Adjustable holder	Sealing disc set D3	Screw to adjust the height	Coolant supply	Clamping nut
N.07.IK	64.600.16.3-10	002.00.69	004.00.19	62.000.16
N.41.IK	64.600.20.3-13	002.00.69	004.00.19	62.000.20

Adjustable holder

N



with chucking nut ER16 system Graf

for Basic Holder

Type Horn BGT
Graf G

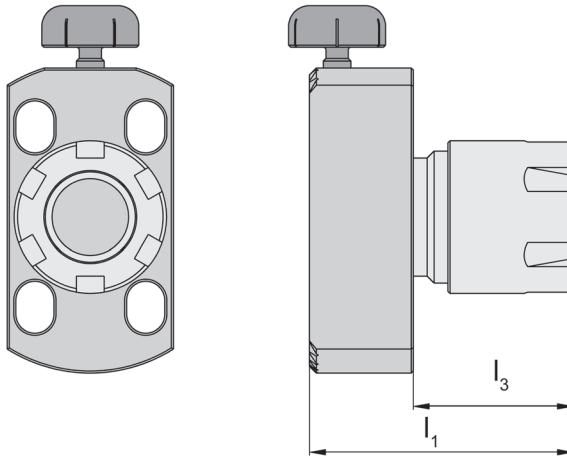

Part number	l_1	l_3	Clamping nut
N.07	37	18	ER16

Further sizes upon request

Dimensions in mm

Spare Parts

Adjustable holder	Screw to adjust the height	Clamping nut
N.07	002.00.69	62.000.16

Adjustable holder

N



with chucking nut ER11 / ER16 system Graf

for Basic Holder

Type Horn BGT
Graf G

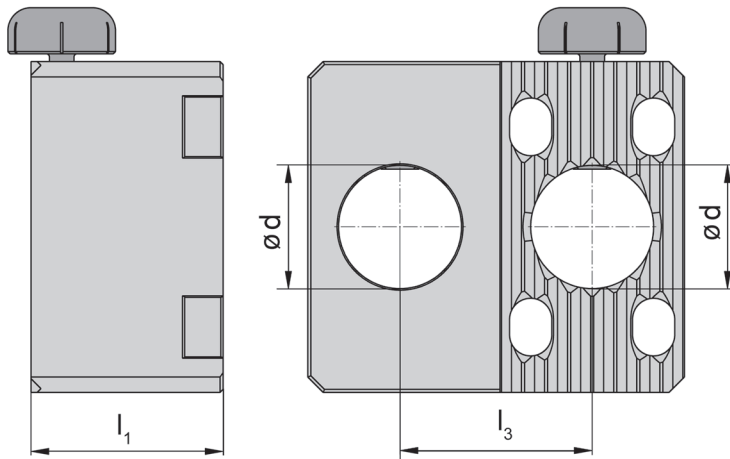

Part number	d	l ₁	l ₃
N.10	16	25	25

Further sizes upon request

Dimensions in mm

Spare Parts

Adjustable holder	Threaded Pin	Screw to adjust the height
N.10	002.00.11	002.00.69

Adjustable holder

N



for square shank system Graf

for Basic Holder

Type Horn BGT
 Graf G

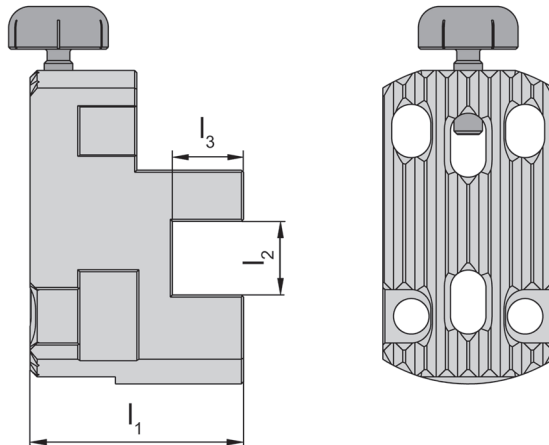

Part number	l_1	l_3	l_2
N06	30	10	10

Further sizes upon request

Dimensions in mm

Spare Parts

Adjustable holder	Threaded Pin	Screw to adjust the height
N06	002.00.11	002.00.69

Toolholder

BU108

with through coolant supply

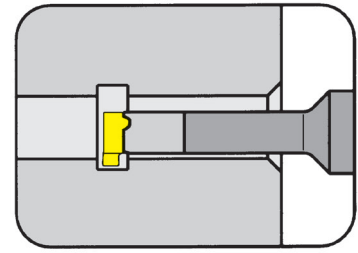

Bore Ø from	.315"
Depth of groove up to	.039"
Width of groove up to	.079"

Material of shank: Carbide - Giving a good vibration resistance

for Insert

Type 108
S108

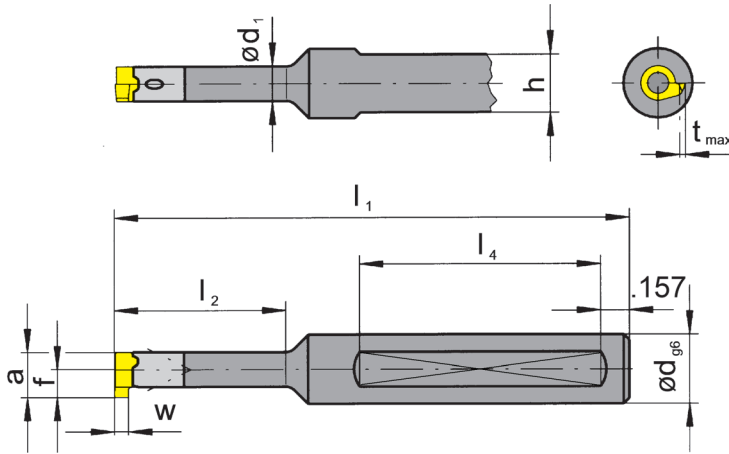

Picture = right hand cutting version

Part number	d	l ₁	l ₂	h	l ₄	d ₁
BU108.0500.01	.500	3.150	.827	.460	1.772	.236
BU108.0500.02	.500	3.543	1.181	.460	1.772	.236
BU108.0500.03	.500	3.937	1.654	.460	1.772	.236
BU108.ST05.00	.500	2.756	.492	.460	1.575	.236

Further sizes upon request

w, a, t_{max} and f see inserts

Dimensions in inch

Ordering note:

Toolholders can be used with right and left hand inserts. Toolholders with damaged seating can be repaired by HORN.

For torque specification of the screw, please see Technical Instructions.

ST in the part number denotes a steel shank.

Spare Parts

Toolholder	Clamping Screw	TORX PLUS® Wrench
BU108...	2.6.5T8EP	T8PL

Toolholder

B108

with through coolant supply

Bore \varnothing from	8 mm
Width of groove up to	2 mm

Material of shank: Carbide - Giving a good vibration resistance

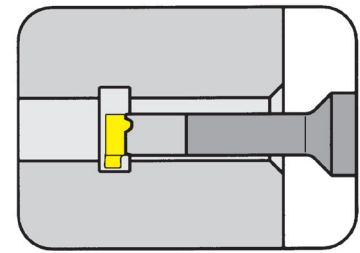

Insert

Type 108
S108

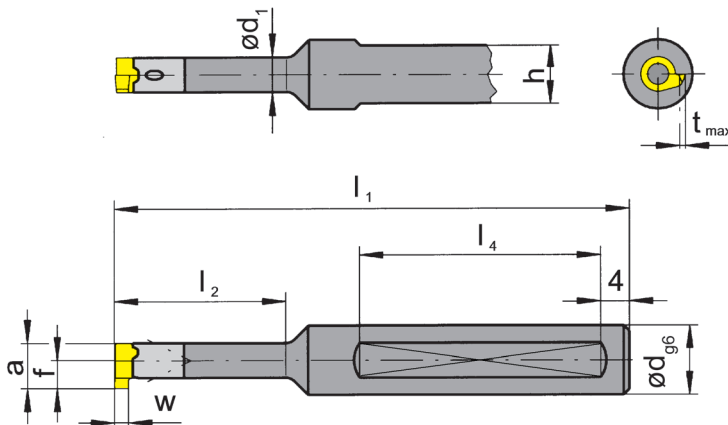

Picture = right hand cutting version

Part number	d	l_1	l_2	h	l_4	d_1
B108.0008.00	8	60	12.5	7	35	6
B108.0008.01	8	70	21.0	7	40	6

Further sizes upon request

w, a, t_{max} and f see inserts

Dimensions in mm

Ordering note:

Toolholders can be used with right and left hand inserts. Toolholders with damaged seating can be repaired by HORN.

For torque specification of the screw, please see Technical Instructions.

Spare Parts

Toolholder	Clamping Screw	TORX PLUS® Wrench
B108...	2.6.5T8EP	T8PL

Toolholder

BU111

with through coolant supply

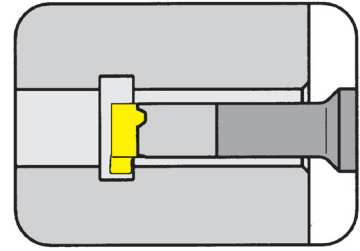

Bore Ø from	.433"
Depth of groove	.091"
Width of groove up to	.125"

Material of shank: Carbide - Giving a good vibration resistance

for Insert

Type 111
S111

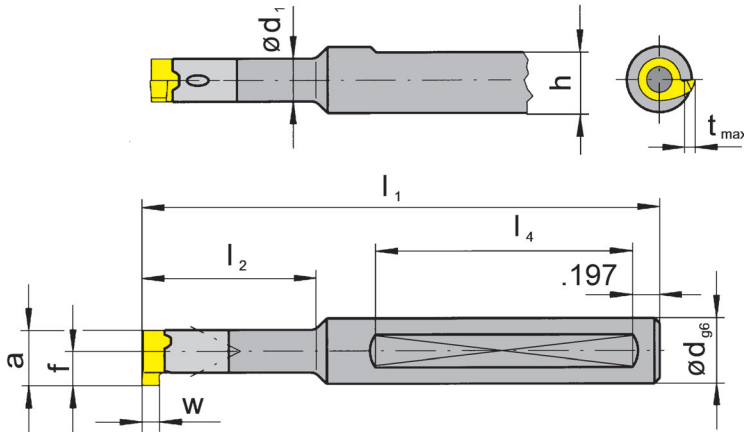

Picture = right hand cutting version

Part number	d	l ₁	l ₂	h	l ₄	d ₁
BU111.0500.01	.500	3.740	1.142	.461	1.969	.315
BU111.0500.02	.500	4.331	1.654	.461	1.969	.315
BU111.0500.03	.500	4.724	2.205	.461	1.969	.315
BU111.ST05.00	.500	2.953	.650	.460	1.575	.315

Further sizes upon request

w, a, t_{max} and f see inserts

Dimensions in inch

Ordering note:

Toolholders can be used with right and left hand inserts. Toolholders with damaged seating can be repaired by HORN.

For torque specification of the screw, please see Technical Instructions.

* Steel toolholder is not repairable.

Spare Parts

Toolholder	Clamping Screw	TORX PLUS® Wrench
BU111...	3.5.12T10EP	T10PL

Toolholder

B111

with through coolant supply

Bore \varnothing from
Depth of groove
Width of groove up to

11 mm
2.3 mm
3 mm

Material of shank: Carbide - Giving a good vibration resistance

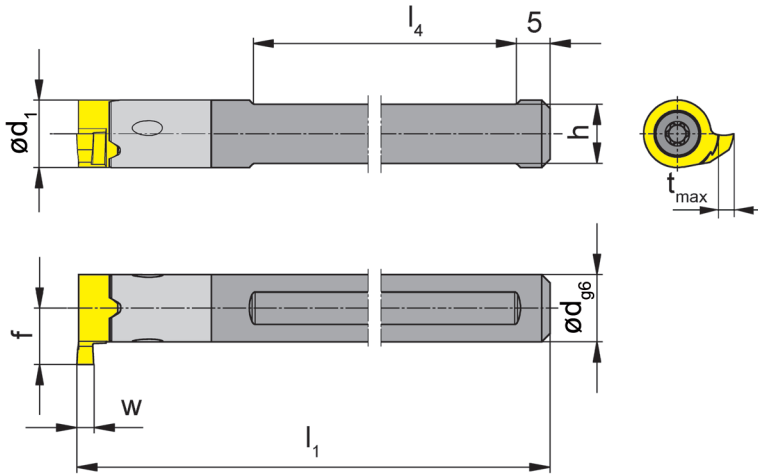
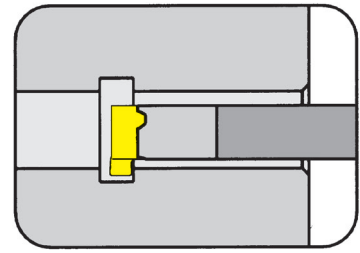

for Insert

Type 111
S111

Picture = right hand cutting version

Part number	d	l_1	h	l_4	d_1
B111.0008.01	8	80	7	55	8

Further sizes upon request

w, a, t_{max} and f see inserts

Dimensions in mm

Ordering note:

Toolholders can be used with right and left hand inserts. Toolholders with damaged seating can be repaired by HORN.

For torque specification of the screw, please see Technical Instructions.

Spare Parts

Toolholder	Clamping Screw	TORX PLUS® Wrench
B111.0008.01	3.5.12T10EP	T10PL

Toolholder

H100

with screwed clamping

Depth of groove up to
Width of groove

17 mm
2 - 3 mm

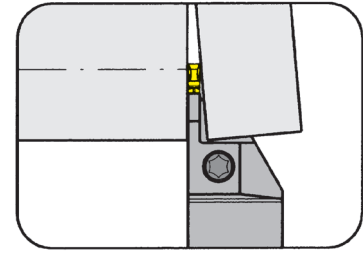

for Insert

Type S100

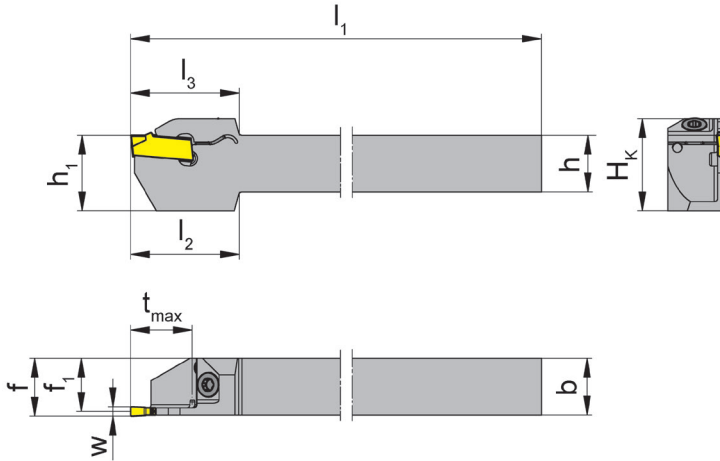

R = right hand version shown

L = left hand version

for Swiss type machines

Part number	h	b	l_1	l_2	l_3	h_1	f_1	f	t_{max}	D_{max}	H_k	Size
R/LH100.1212.24.61	12	12	125	23	23	16	11.25	$f_1+w/2$	13	26	19.5	02
R/LH100.1616.24.61	16	16	125	23	-	16	15.25	$f_1+w/2$	13	26	19.5	02
R/LH100.1212.32.63	12	12	125	27	24	16	10.85	$f_1+w/2$	17	34	19.5	03
R/LH100.1616.32.63	16	16	125	27	-	16	14.85	$f_1+w/2$	17	34	19.5	03

State R or L version

w see inserts

Dimensions in mm

Further sizes upon request

For torque specification of the screw, please see Technical Instructions.

Spare Parts

Toolholder	Clamping Screw	TORX PLUS® Wrench
R/LH100...	3.5.12T10EP	T10PL

Toolholder

H264

with screwed clamping

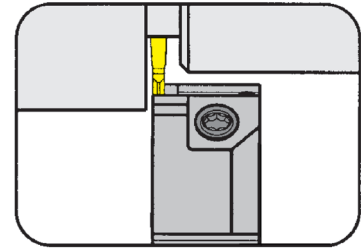

Depth of groove
Width of groove

4 - 16 mm
1.5 - 2 mm

For Indexable insert

Type 264
S264

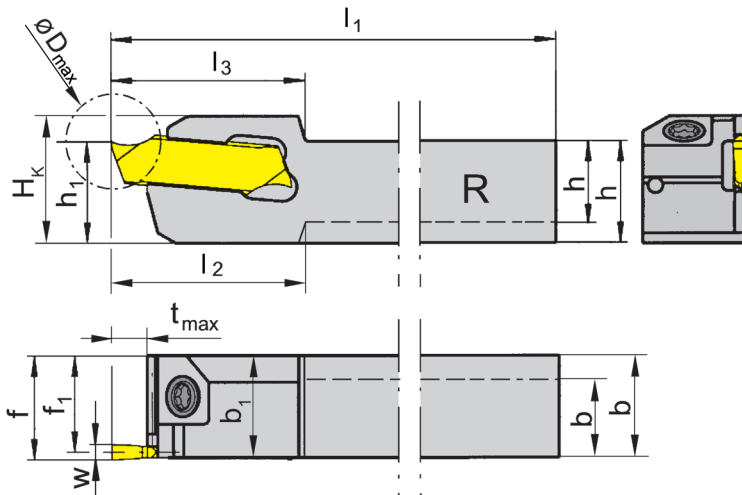

R = right hand version shown

L = left hand version

Part number	h	b	l ₁	l ₂	l ₃	h ₁	b ₁	f ₁	f	t _{max}	D _{max}	H _K	Size
R/LH264.0808.01	8	10	120	17.5	17.5	8	10	9.25	10	4	22	12.5	01
R/LH264.1010.01	10	10	120	-	17.5	10	-	9.25	10	4	22	12.5	01
R/LH264.1212.01	12	12	120	-	17.5	12	-	11.25	12	4	22	14.5	01
R/LH264.1616.01	16	16	120	-	17.5	16	-	15.25	16	4	32	18.5	01
R/LH264.1010.11	10	10	120	-	19.0	10	-	9.25	10	10	20	12.5	01
R/LH264.1212.11	12	12	120	-	19.0	12	-	11.25	12	10	20	14.5	01
R/LH264.1616.11	16	16	120	-	19.0	16	-	15.25	16	10	32	18.5	01
R/LH264.1212.21	12	12	120	-	22.0	12	-	11.25	12	13	26	15.5	01
R/LH264.1616.21	16	16	120	-	22.0	16	-	15.25	16	13	32	19.5	01
R/LH264.1010.02	10	10	120	-	17.5	10	-	9.00	10	4	32	12.5	02
R/LH264.1212.02	12	12	120	-	17.5	12	-	11.00	12	4	32	14.5	02
R/LH264.1616.02	16	16	120	-	17.5	16	-	15.00	16	4	32	18.5	02
R/LH264.1010.12	10	10	120	-	19.0	10	-	9.00	10	10	32	12.5	02
R/LH264.1212.12	12	12	120	-	19.0	12	-	11.00	12	10	32	14.5	02
R/LH264.1616.12	16	16	120	-	19.0	16	-	15.00	16	10	32	18.5	02
R/LH264.1212.22	12	12	120	-	25.0	12	-	11.00	12	16	32	14.5	02
R/LH264.1616.22	16	16	120	-	25.0	16	-	15.00	16	16	32	19.5	02

State R or L version

w see inserts

Further sizes upon request

Dimensions in mm

For torque specification of the screw, please see Technical Instructions.

Spare Parts

Toolholder	Clamping Screw	TORX PLUS® Wrench
R/LH264...	3.5.12T10EP	T10PL

Toolholder

H264

with screwed clamping

Depth of groove up to
Width of groove

16 mm
2.5 mm

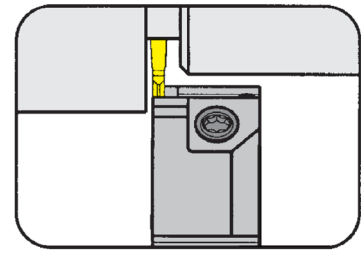

For Indexable insert

Type 264
S264

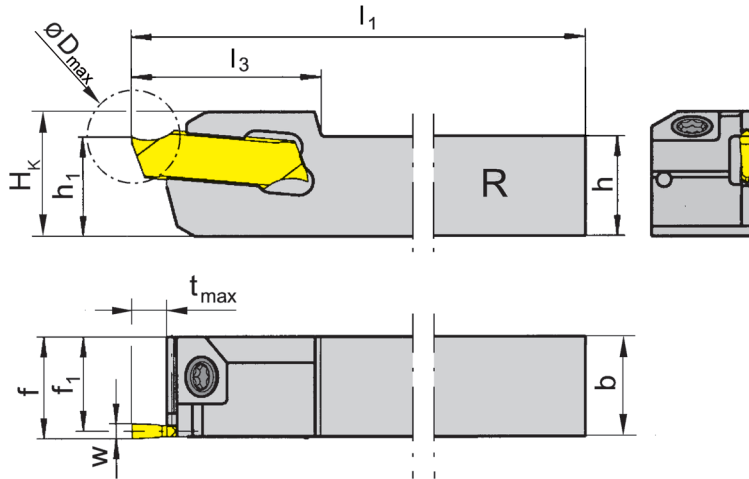

R = right hand version shown

L = left hand version

Part number	h	b	l ₁	l ₃	h ₁	f ₁	f	t _{max}	D _{max}	H _k	Size
R/LH264.1212.03	12	12	120	17.5	12	10.75	12	4	32	14.5	03
R/LH264.1616.03	16	16	120	17.5	16	14.75	16	4	32	18.5	03
R/LH264.1212.13	12	12	120	19.0	12	10.75	12	10	32	14.5	03
R/LH264.1616.13	16	16	120	19.0	16	14.75	16	10	32	18.5	03
R/LH264.1212.23	12	12	120	25.0	12	10.75	12	16	32	14.5	03
R/LH264.1616.23	16	16	120	25.0	16	14.75	16	16	32	18.5	03

State R or L version

w see inserts

Dimensions in mm

Further sizes upon request

For torque specification of the screw, please see Technical Instructions.

Spare Parts

Toolholder	Clamping Screw	TORX PLUS® Wrench
R/LH264...	3.5.12T10EP	T10PL

Toolholder

H264

with screwed clamping

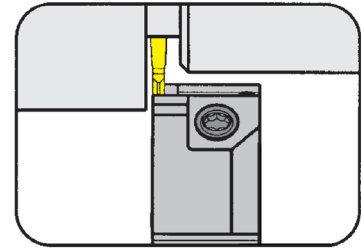

Depth of groove up to
Width of groove

16 mm
3 mm

For Indexable insert

Type 264
S264

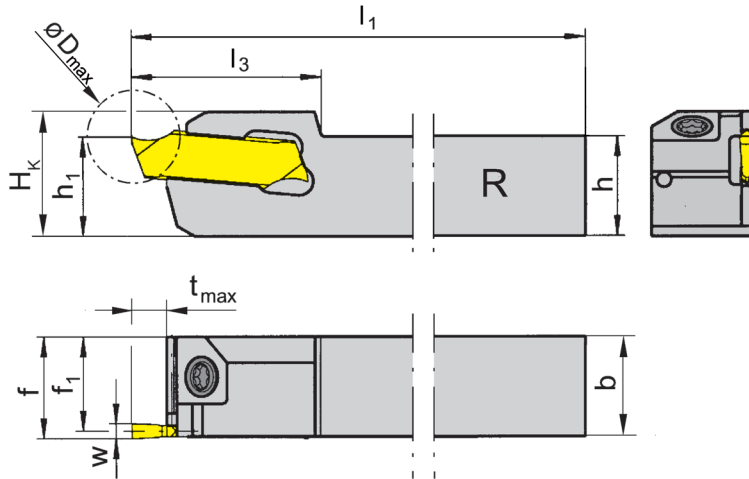

R = right hand version shown

L = left hand version

Part number	h	b	l_1	l_3	h_1	f_1	f	t_{max}	D_{max}	H_K	Size
R/LH264.1212.04	12	12	120	17.5	12	10.5	12	5	32	15	04
R/LH264.1616.04	16	16	120	17.5	16	14.5	16	5	32	19	04
R/LH264.1212.14	12	12	120	19.0	12	10.5	12	10	32	15	04
R/LH264.1616.14	16	16	120	19.0	16	14.5	16	10	32	19	04
R/LH264.1212.24	12	12	120	25.0	12	10.5	12	16	32	15	04
R/LH264.1616.24	16	16	120	25.0	16	14.5	16	16	32	19	04

State R or L version

w see inserts

Dimensions in mm

Further sizes upon request

For torque specification of the screw, please see Technical Instructions.

Spare Parts

Toolholder	Clamping Screw	TORX PLUS® Wrench
R/LH264...	3.5.12T10EP	T10PL

Toolholder

H264

with self clamping

Depth of groove up to
Width of groove

10 mm
1.5 - 3 mm

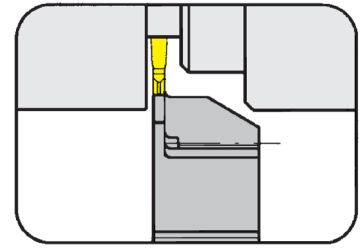

For Indexable insert

Type 264
S264

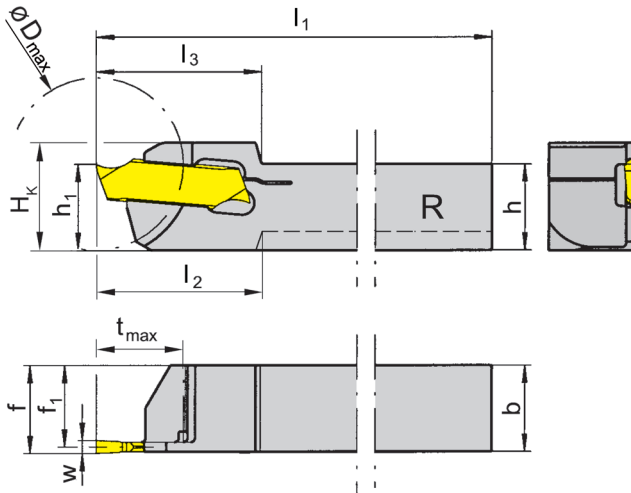

R = right hand version shown

L = left hand version

Part number	h	b	l ₁	l ₂	l ₃	h ₁	f ₁	f	t _{max}	D _{max}	H _K	Size
R/LH264.0808.51	8	8	120	18	18	10	7.25	8	7	20	12.5	01
R/LH264.1010.61	10	10	120	-	19	10	9.25	10	10	20	12.5	01
R/LH264.1010.62	10	10	120	-	19	10	9.00	10	10	20	12.5	02
R/LH264.1212.62	12	12	120	-	19	12	11.00	12	10	20	14.5	02
R/LH264.1212.63	12	12	120	-	19	12	10.75	12	10	32	14.5	03
R/LH264.1212.64	12	12	120	-	19	12	10.50	12	10	32	14.5	04

State R or L version

w see inserts

Dimensions in mm

Further sizes upon request

Note:

Wrench **P39L** is not combined with blade R/LH100...33 - separate order required!

Spare Parts

Toolholder	Wrench
R/LH264...	P39L

Grooving (external)



Toolholder

U248

Depth of groove up to .157"
Clamping range .035 - .106"

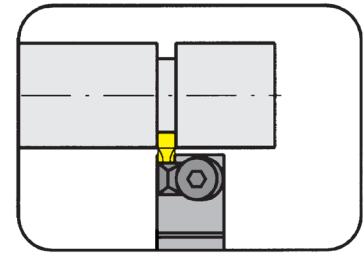

for Indexable insert

Type 217
U217

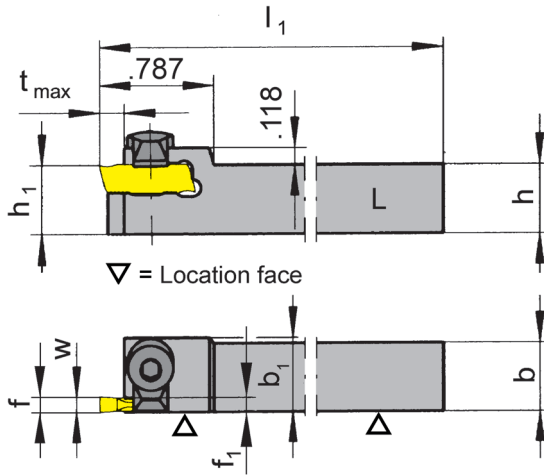

R = right hand version shown

L = left hand version

Part number	h	b	l ₁	h ₁	b ₁	f ₁	f	t _{max}	Size	Clamping range
R/LU248.0500.01	.500	.500	3.740	.500	.539	.480	f ₁ +a ₁	.157	01	.035 - .067
R/LU248.0500.02	.500	.500	3.740	.500	.539	.445	f ₁ +a ₁	.157	02	.067 - .106

State R or L version

w, a₁ see indexable inserts

Dimensions in inch

Further sizes upon request

For torque specification of the screw, please see Technical Instructions.

Spare Parts

Toolholder	Allen wrench	Clamping element
R/LU248...	SW2,5 DIN911	8.3



Grooving (external)



Toolholder

248

Depth of groove up to
Clamping range

4 mm
0.5 - 2.7 mm

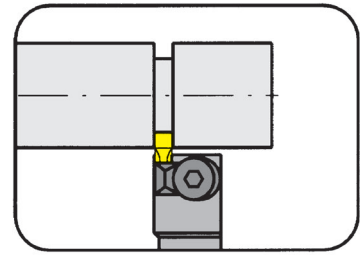

For Indexable insert

Type 217
U217

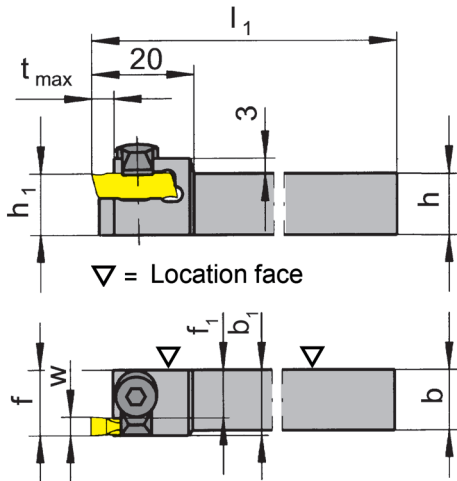

R = right hand version shown

L = left hand version

Part number	h	b	l_1	h_1	b_1	f_1	f	t_{max}	Size	Clamping range
R/L248.1212.01	12	12	95	12	13	1.5	f_1+a_1	4	01	.5 - 1.7
R/L248.1212.02	12	12	95	12	13	2.5	f_1+a_1	4	02	1.7 - 2.7

State R or L version

w, a_1 see indexable inserts

Dimensions in mm

Further sizes upon request

For torque specification of the screw, please see Technical Instructions.

Spare Parts

Toolholder	Allen wrench	Clamping element
R/L248...	SW2.5 DIN911	8.3

Cartridge

KT274

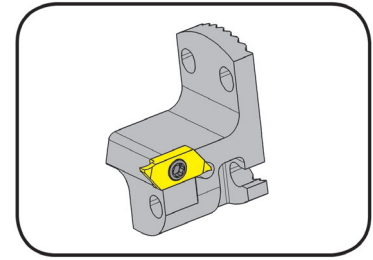

Depth of groove up to
Width of groove

6 mm
0.5 - 3 mm

For Indexable insert

Type S274

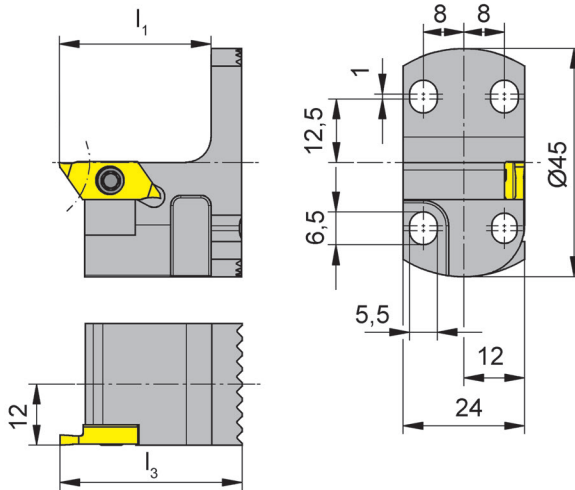

R = right hand version shown

L = left hand version

Part number	l_3	l_1	Size
R/LKT274.2445.04	36	30	04

State R or L version

Dimensions in mm

Further sizes upon request

For torque specification of the screw, please see Technical Instructions.

Spare Parts

Cartridge	Clamping Screw	TORX PLUS® Wrench
R/LKT274.2445.04	030.3509.T15P	T15PQ



Cartridge

KTC274

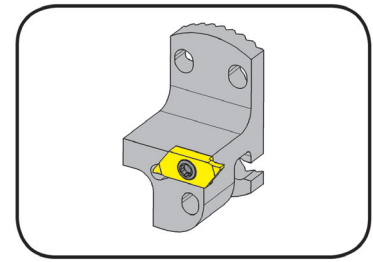

Depth of groove up to
Width of groove

6 mm
0.5 - 3 mm

For Indexable insert

Type S274

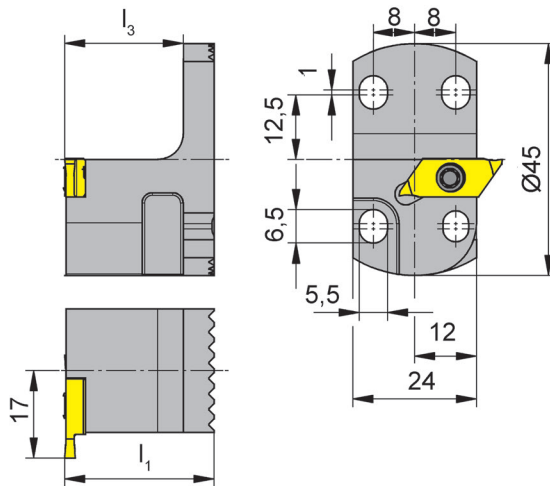

R = right hand version shown

Part number	l_1	l_3	Size
RKTC274.2445.04	29	23	04

Further sizes upon request

Dimensions in mm

Ordering note:

Use left hand insert in right hand toolholder.

For torque specification of the screw, please see Technical Instructions.

Spare Parts

Cartridge	Clamping Screw	TORX PLUS® Wrench
RKTC274.2445.04	030.3509.T15P	T15PQ

Toolholder

H274

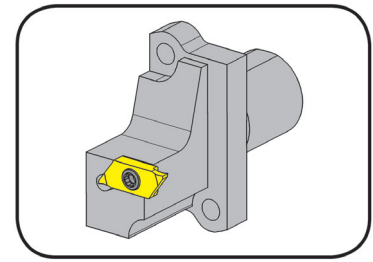

Depth of groove up to
Width of groove up to

6 mm
7 mm

Hole pattern 13.7 x 37.6 mm

For Indexable insert

Type S274

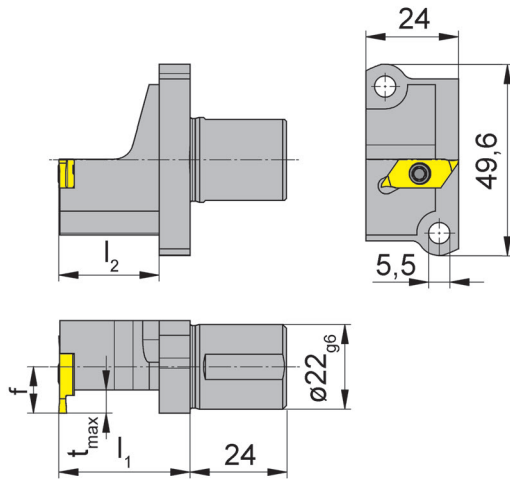

R = right hand version shown

L = left hand version

for Swiss type machines
Star

S

Part number	f	l_1	t_{max}	l_2	Size
R/LH274.A022.09.04	9	34	6	26	04
R/LH274.A022.12.04	12	34	6	26	04
R/LH274.A022.16.04	16	34	6	26	04
R/LH274.A022.09.07	9	34	6	26	07
R/LH274.A022.12.07	12	34	6	26	07

State R or L version

Dimensions in mm

Further sizes upon request

Ordering note:

Use right hand inserts in left hand toolholders and left hand inserts in right hand toolholders

For torque specification of the screw, please see Technical Instructions.

Spare Parts

Toolholder	Clamping Screw	TORX PLUS® Wrench
R/LH274...	030.3513.T15P	T15PQ

Toolholder

H224

Depth of groove up to 10.5 mm
Clamping range 2 - 3.7 mm

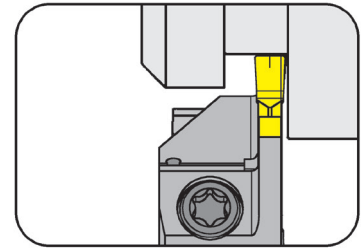

For Indexable insert

Type S224
NS224

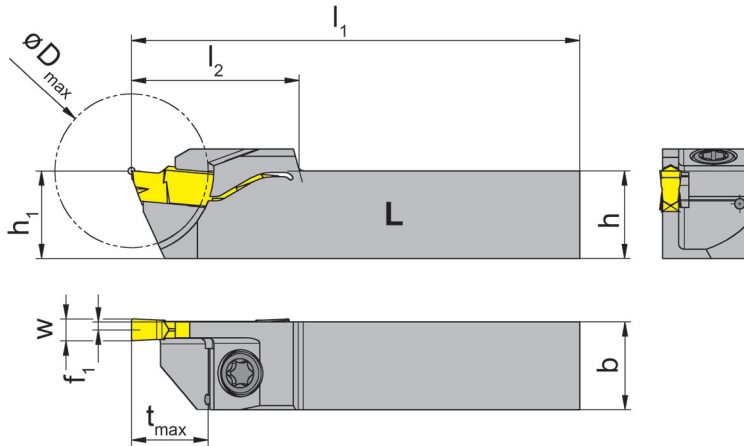

L = left hand version shown

R = right hand version

Part number	h	b	l ₁	l ₂	h ₁	f ₁	t _{max}	D _{max}	Size	Clamping range
R/LH224.1212.20.61	12	12	100	23	12	0.7	10.5	21	01	2.0 - 2.4
R/LH224.1212.20.62	12	12	100	23	12	0.9	10.5	21	02	2.4 - 2.8
R/LH224.1212.20.63	12	12	100	23	12	1.1	10.5	21	03	2.8 - 3.7

State R or L version

w see indexable inserts

Dimensions in mm

Further sizes upon request

For torque specification of the screw, please see Technical Instructions.

Spare Parts

Toolholder	Clamping Screw	TORX PLUS® Wrench
R/LH224...	4.12T15EP	T15PQ

Toolholder

H224

with screwed clamping

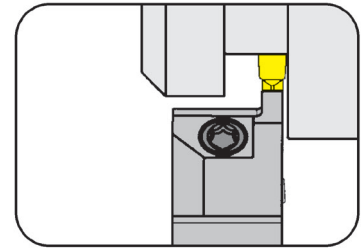

Depth of groove up to
Clamping range

7 mm
2 - 6.1 mm

For Indexable insert

Type S224
NS224

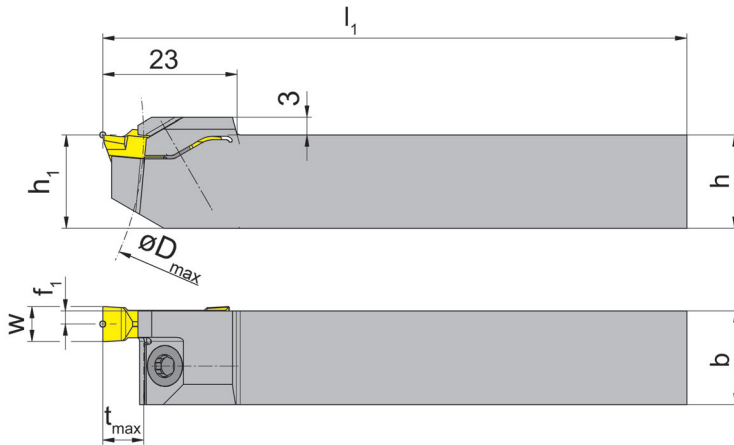

L = left hand version shown

R = right hand version

Part number	h	b	l ₁	h ₁	f ₁	t _{max}	D _{max}	Size	Clamping range
R/LH224.1212.61	12	12	100	12	.70	7	100	01	2.0 - 2.4
R/LH224.1616.61	16	16	100	16	.70	7	100	01	2.0 - 2.4
R/LH224.1212.62	12	12	100	12	.90	7	100	02	2.4 - 2.8
R/LH224.1616.62	16	16	100	16	.90	7	100	02	2.4 - 2.8
R/LH224.1212.63	12	12	100	12	1.10	7	100	03	2.8 - 3.7
R/LH224.1616.63	16	16	100	16	1.10	7	100	03	2.8 - 3.7
R/LH224.1212.64	12	12	100	12	1.45	7	100	04	3.7 - 4.4
R/LH224.1616.64	16	16	100	16	1.45	7	100	04	3.7 - 4.4
R/LH224.1616.65	16	16	100	16	1.85	7	100	05	4.4 - 5.1
R/LH224.1616.66	16	16	100	16	2.25	7	100	06	5.1 - 6.1

State R or L version

w see indexable inserts

Dimensions in mm

Further sizes upon request

For torque specification of the screw, please see Technical Instructions.

Spare Parts

Toolholder	Clamping Screw	TORX PLUS® Wrench
R/LH224...	4.12T15EP	T15PL
R/LH224.1616...	5.13T20EP	T20PQ

Toolholder

368

Depth of groove up to
Width of groove

8 mm
0.5 - 1.5 mm

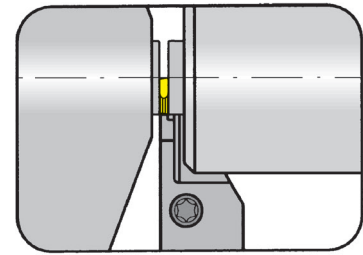

Tool for Tornos

For Indexable insert

Type 312
U312
S312
US312

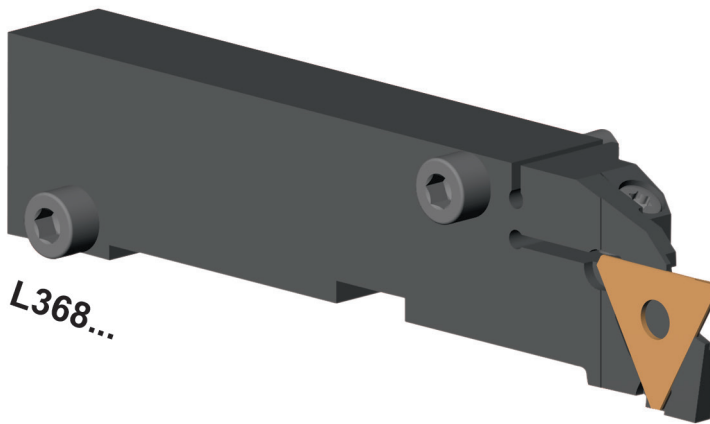

L368...

S

Part number	t _{max}	w _{min}	w _{max}	Machine type	Insert
L368.0710.08	8	.5	1.2	EvoDECO 10	R/L312.0805... R/L312.0808... R/L312.0510... R/L312.0512... R/L312.1210... 312.0012...
L368.0710.11	8	1.5	1.5	EvoDECO 10	R/L312.0515... 312.0015...

Further sizes upon request

Dimensions in mm

For torque specification of the screw, please see Technical Instructions.

Spare Parts

Toolholder	Clamping Screw	Allen wrench	TORX PLUS® Wrench	Straight pin
L368...	4.18T15EP	SW4,0 DIN911	T15PQ	020.0518.1610

Basic toolholder

L760

Depth of groove up to
Width of groove

15 mm
0.5 - 3.7 mm

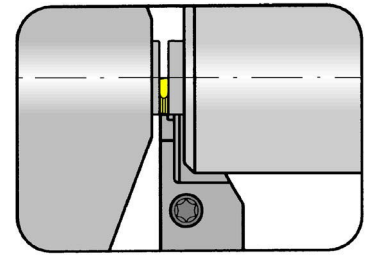

Tool for Tornos

for Cassette

Type LNK368
LNK760

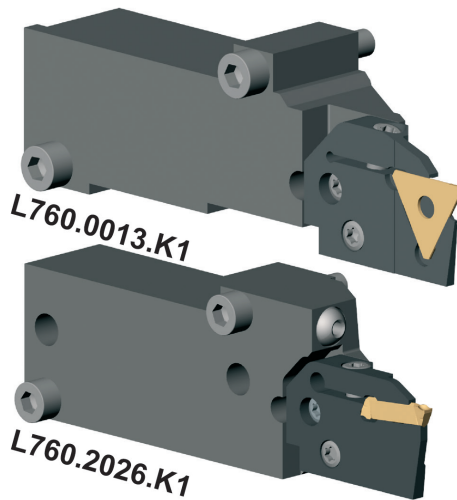

S

Part number	t _{max}	W	Machine type	Cassette	Insert
L760.0013.K1	8	0.5-1.2	Deco13	LNK368.0760.08	R/L312.0805... R/L312.0808... R/L312.0510... R/L312.0512... R/L312.1210... 312.0012...
L760.0013.K1	8	1.5	Deco13	LNK368.0760.11	R/L312.0515... 312.0015...
L760.2026.K1	15	2.0 - 2.4 2.4 - 2.8 2.8 - 3.7	Deco20/26	LNK760.0224.01 LNK760.0224.02 LNK760.0224.03	S224...

Further sizes upon request

Dimensions in mm

Spare Parts

Basic toolholder	Allen wrench
L760...	SW5,0 DIN911

Cassette

LNK368/LNK760

Depth of groove up to
Width of groove

15 mm
0.5 - 3.7 mm

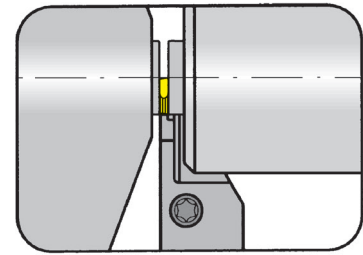

Tool for Tornos

For Indexable insert

Type 312
S224

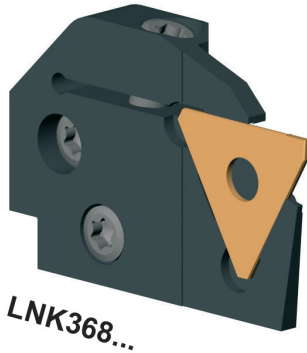

LNK368...

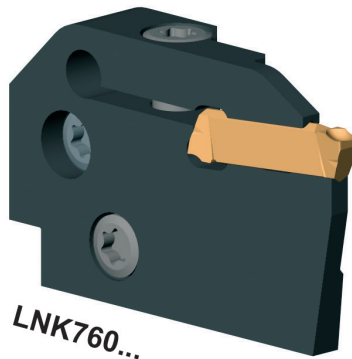

LNK760...

Part number	t _{max}	W _{min}	W _{max}	Machine type	Insert
LNK368.0760.08	9	0.5	1.2	EvoDECO 16	R/L312.0805... R/L312.0808... R/L312.0510... R/L312.0512... R/L312.1210... 312.0012...
LNK368.0760.11	9	1.5	1.5	EvoDECO 16	R/L312.0515... 312.0015...
LNK760.0224.01	15	2.0	2.4	EvoDECO 20/EvoDECO 32	S224
LNK760.0224.02	15	2.4	2.8	EvoDECO 20/EvoDECO 32	S224
LNK760.0224.03	15	2.8	3.7	EvoDECO 20/EvoDECO 32	S224

Further sizes upon request

Dimensions in mm

For torque specification of the screw, please see Technical Instructions.

Spare Parts

Cassette	Clamping Screw	TORX PLUS® Wrench
LNK368.0760...	5.10T20P	T20PQ
LNK760.0224....	5.12T20P	T20PQ

Grooving (external)



Toolholder

361

reduced head size

Depth of groove up to
Clamping range

6 mm
0.5 - 3.9 mm

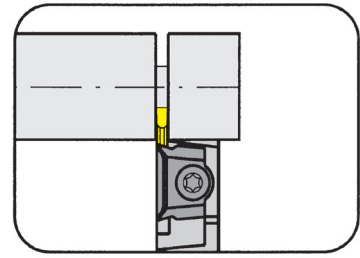

For Indexable insert

Type 312
U312
S312
US312
N312

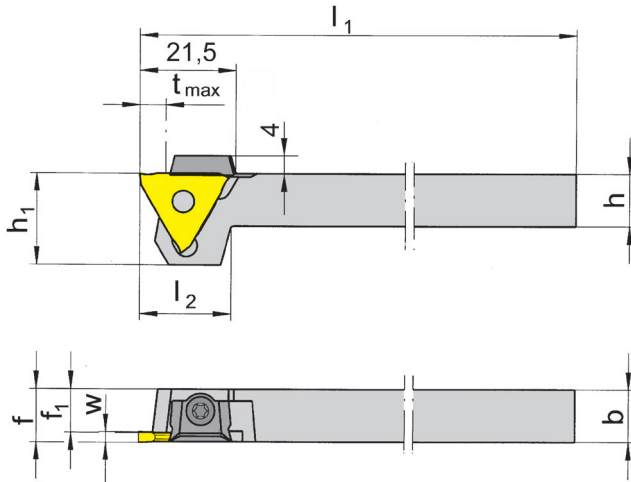

R = right hand version shown

L = left hand version

Part number	h	b	l ₁	l ₂	h ₁	f ₁	f	t _{max}	Size	Clamping range
R/L361.1212.01	12	12	100	17	19	10.5	f ₁ +w-a ₁	4	01	.5 - 1.9
R/L361.1212.02	12	12	100	17	19	9.5	f ₁ +w-a ₁	6	02	1.9 - 2.9
R/L361.1212.03	12	12	100	21	21	8.5	f ₁ +w-a ₁	6	03	2.9 - 3.9

State R or L version

w, a₁ see indexable inserts

Dimensions in mm

Further sizes upon request

t_{max} can be reached only with workpiece Ø ≤ 40 mm

Spare Parts

Toolholder	Clamping element	Clamping Screw	TORX PLUS® Wrench
R/L361...	12.3	030.0422.T10P	T10PL

Toolholder

368

Depth of groove up to
Width of groove

8 mm
0.5 - 1.5 mm

for machines TRAUB (TNL12/7)

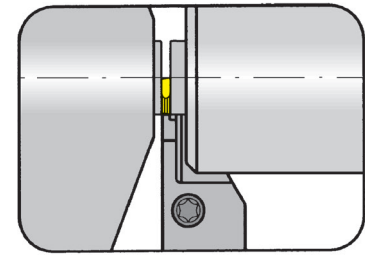

For Indexable insert

Type 312

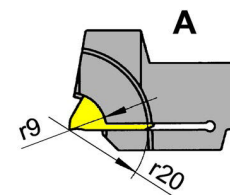

only for peripheral ground profiled inserts

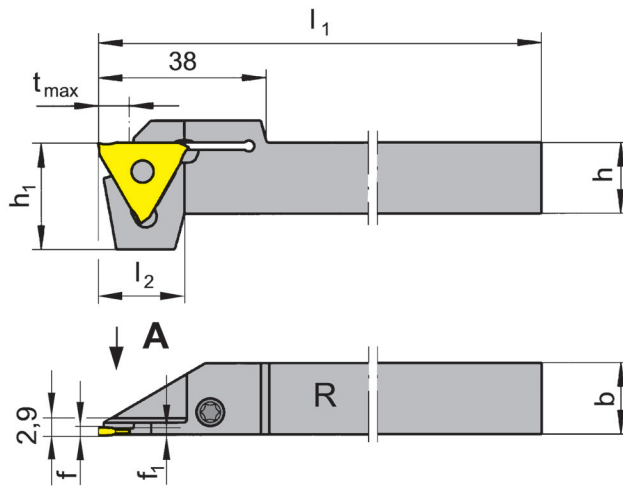

R = right hand version shown

L = left hand version

Part number	h	b	l ₁	l ₂	h ₁	f ₁	f	t _{max}
R/L368.1212.08	12	12	95	19.5	24	1.0	f ₁ +a ₁	8
R/L368.1616.08	16	16	95	19.5	24	1.0	f ₁ +a ₁	8
R/L368.1212.11	12	12	95	19.5	24	1.3	f ₁ +a ₁	8
R/L368.1616.11	16	16	95	19.5	24	1.3	f ₁ +a ₁	8

State R or L version

a1 see indexable inserts

Dimensions in mm

Toolholder R/L368...08 for indexable inserts:

R/L312.0805... / R/L312.0808... / R/L312.0510... R/L312.0512... / R/L312.1210... / R/L312.0012...

Toolholder R/L368...11 for indexable inserts:

R/L312.0515... / R/L312.0015...V1

Spare Parts

Toolholder	Clamping Screw	TORX PLUS® Wrench
R/L368...	4.15T15P	T15PQ

Toolholder

369

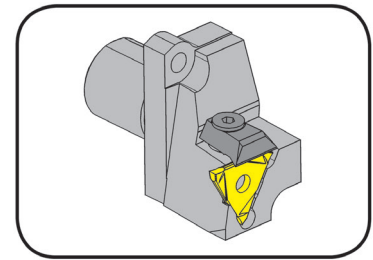

Depth of groove
Clamping range

4 - 6 mm
0.5 - 2.9 mm

Hole pattern 13.7 x 37.6 mm

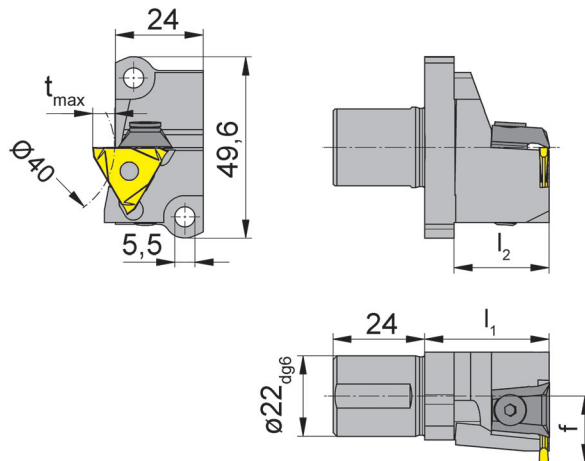

For Indexable insert

Type 312
U312
S312
US312
N312

for Swiss type machines
Star

L = left hand version shown

Part number	l_2	f	t_{max}	l_1	Size	Clamping range
L369.A022.18.01	26	18.2	4	34	01	.5 - 1.9
L369.A022.18.02	26	18.2	6	34	02	1.9 - 2.9

Further sizes upon request

Dimensions in mm

For torque specification of the screw, please see Technical Instructions.

Swiss Type Machines Star: ECAS-12/20, SB16D/E, SR-20, SR20J/JN, RS-20RII, RS-20RIII, RS-20RIV, RS-32J/JN, SW-12RII

Spare Parts

Toolholder	Allen wrench	Clamping element
L369...	SW3,0 DIN911	16.4

Swiss Tooling

Further information on swiss tooling can be found in the catalogs:

W&F: "Modular Technology for Swiss Type Machines"

GRAF: "Tool Systems for Automatic Lathe"



www.phorn.de



www.graf-werkseugsysteme.de



T

System	Page
105	T2
110	T20
114	T26
15A/25A	T44
220/224	T54
229	T76
231	T108
312	T116
A315	T122

Toolholder
B105/H105/HC105/
VDI

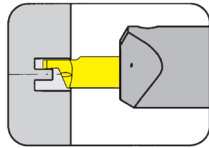

Page
T4-T8

Insert
U105/105

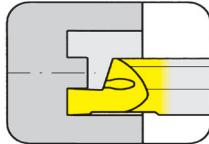

Page
T9-T13

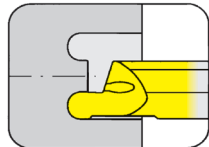

Page
T14-T15

Toolholder
BU105/B105

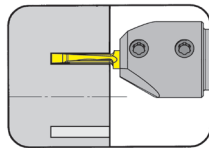

Page
T16-T17

Insert
A105

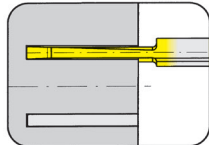

Page
T18

T

105



T

Toolholder with Inserts

Width of groove .079 - .118"

Toolholder

B105

with through coolant supply

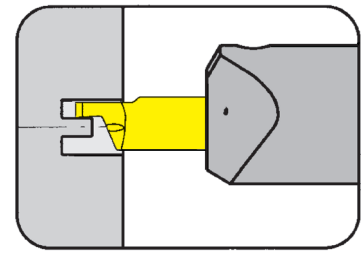

from outer groove \varnothing	5 mm
Depth of groove	6 mm
Width of groove up to	2 mm

for Insert

Type 105
U105

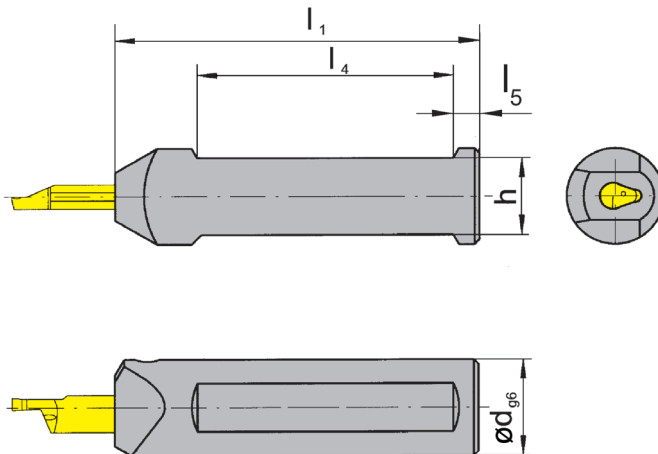

Picture = left hand cutting version

Part number	d	l_1	h	l_4	l_5
B105.0010.01	10	75	9	50	5
B105.0012.01	12	75	11	50	5
B105.0016.01	16	75	14	50	5
B105.0020.01	20	90	18	55	5
B105.0022.01	22	90	20	55	5
B105.0025.01	25	100	23	55	5

Further sizes upon request

Dimensions in mm

Ordering note:

Toolholders can be used with right and left hand inserts.

For torque specification of the screw, please see Technical Instructions.

Spare Parts

Toolholder	Clamping Screw	TORX PLUS® Wrench
B105...	6.075T15P	T15PQ

Toolholder

B105/BU105

with through coolant supply

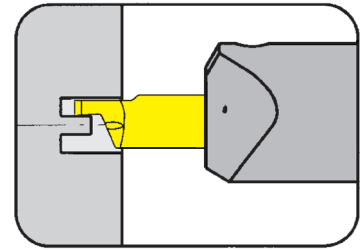

from outer groove \varnothing
Depth of groove up to
Width of groove up to

5 mm
6 mm
2 mm

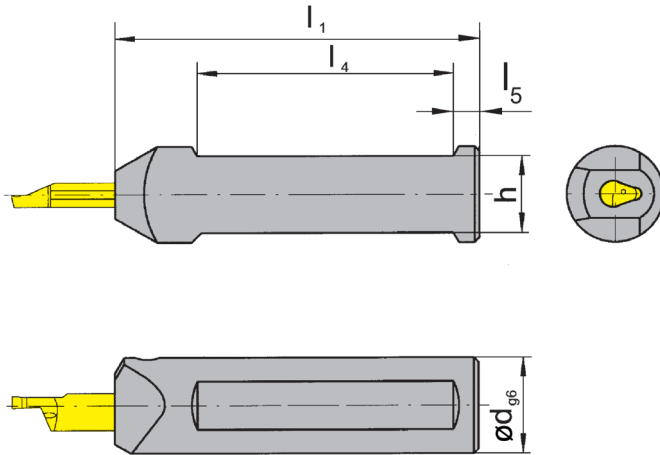

for Insert

Type 105
U105

Picture = right hand cutting version

Part number	d	l_1	h	l_4	l_5
B105.0028.01	28.0	120.0	26.0	72	12
BU105.0750.5.01	3/4"	90.0	17.04	70	5
BU105.0750.5.3.01	3/4"	152.5	17.05	70	5
BU105.1000.5.01	1"	90.0	23.40	65	5
BU105.1000.5.3.01	1"	152.5	23.40	70	5

Further sizes upon request

Dimensions in mm

Adapter of cooling M12x1,5 Coolant supply is not included.

Ordering note:

Toolholders can be used with right and left hand inserts.

For torque specification of the screw, please see Technical Instructions.

Spare Parts

Toolholder	Clamping Screw	TORX PLUS® Wrench
B105...	6.075T15P	T15PQ

Toolholder

H105

with screwed clamping

from outer groove \varnothing
Depth of groove up to
Width of groove up to

5 mm
6 mm
3 mm

with through coolant supply

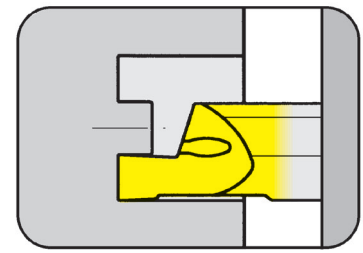

for Insert

Type 105
U105

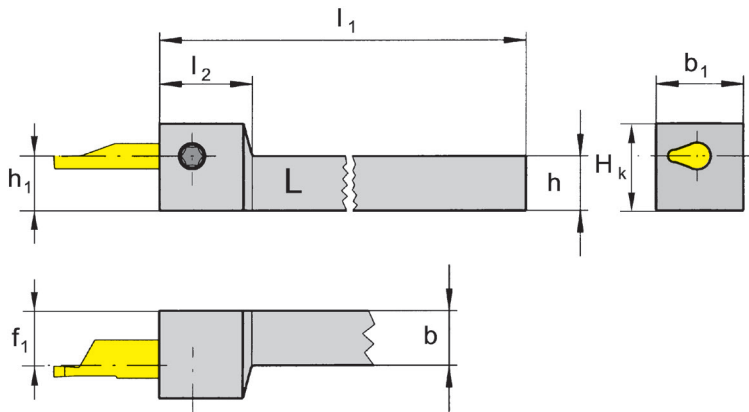

L = left hand version shown

R = right hand version

Part number	h	b	l_1	h_1	b_1	f_1	H_k	l_2
R/LH105.0808.01	8	8	90	8	16	7.5	14	17
R/LH105.1010.01	10	10	90	10	16	7.5	16	17
R/LH105.1212.01	12	12	90	12	16	7.5	18	17
R/LH105.1616.01	16	16	110	16	16	7.5	22	17

State R or L version

Dimensions in mm

Further sizes upon request

For torque specification of the screw, please see Technical Instructions.

Spare Parts

Toolholder	Clamping Screw	TORX PLUS® Wrench
R/LH105...	6.075T15P	T15PQ

Toolholder

HC105

with screwed clamping

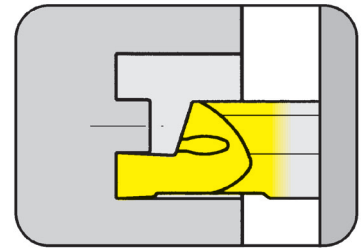

from outer groove \varnothing
Depth of groove up to
Width of groove up to

5 mm
6 mm
2 mm

Coolant supply through cranked fitting

for Insert

Type 105
U105

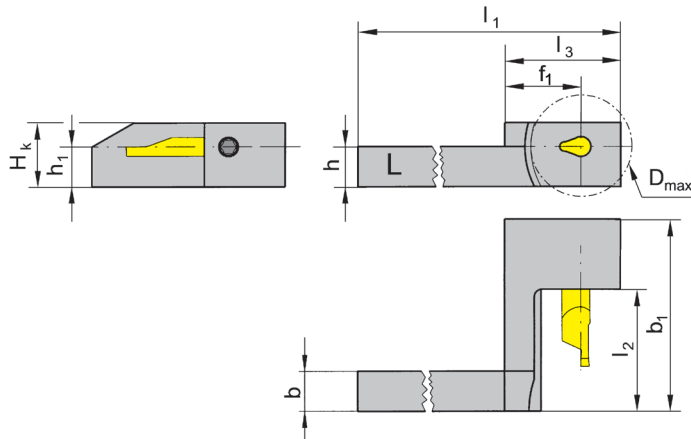

L = left hand version shown

R = right hand version

Part number	h	b	l_1	l_3	h_1	b_1	f_1	$D_{a\ max}$	H_K	l_2
R/LHC105.0707.21	7	7	99	29	7	32.0	19	26	13	18
R/LHC105.0808.21	8	8	99	29	8	32.0	19	26	13	18
R/LHC105.0812.21	8	12	99	29	8	32.0	19	26	13	18
RHC105.1010.11	10	10	99	29	10	22.7	19	26	16	8
R/LHC105.1010.21	10	10	99	29	10	38.0	19	26	16	18
R/LHC105.1010.41	10	10	99	29	10	48.0	19	26	16	28
R/LHC105.1212.21	12	12	99	29	12	38.0	19	26	18	18
R/LHC105.1212.41	12	12	99	29	12	48.0	19	26	18	28
R/LHC105.1616.21	16	16	104	34	16	38.0	24	36	22	18
R/LHC105.1616.41	16	16	104	34	16	48.0	24	36	22	28

State R or L version

Dimensions in mm

Further sizes upon request

Note:

R/LHC105.07.../08.../1010.11 = no through coolant supply!

For torque specification of the screw, please see Technical Instructions.

Spare Parts

Toolholder	Clamping Screw	TORX PLUS® Wrench	SMC angled screw coupling
R/LHC105.0707...	6.075T15P	T15PQ	
R/LHC105.0808...	6.075T15P	T15PQ	
R/LHC105.1010...	6.075T15P	T15PQ	
R/LHC105....	6.075T15P	T15PQ	KQ2L06-M5

Toolholder

VDI

with through coolant supply

from outer groove \varnothing
Depth of groove up to
Width of groove up to

5 mm
6 mm
3 mm

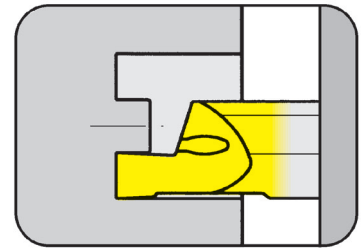

for Insert

Type 105
U105

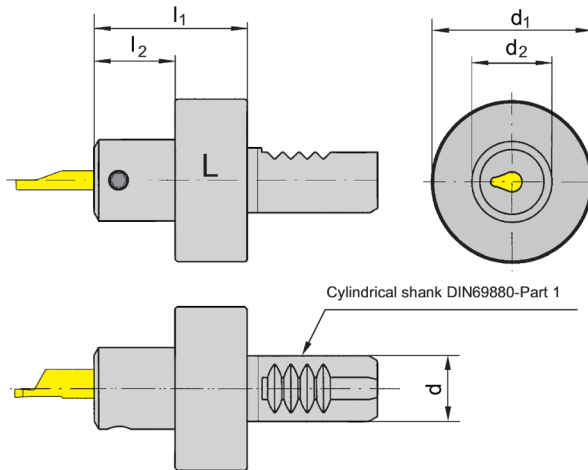

L = left hand version shown

R = right hand version

Part number	d	l_1	l_2	d_2	d_1
VDI16.L105.20.01	16	38	20	20	40
VDI16.R105.20.01	16	38	20	20	40
VDI20.L105.20.01	20	38	20	20	50
VDI20.R105.20.01	20	38	20	20	50
VDI25.L105.20.01	25	38	20	20	58
VDI25.R105.20.01	25	38	20	20	58
VDI30.L105.20.01	30	38	20	20	68
VDI30.R105.20.01	30	38	20	20	68
VDI40.L105.20.01	40	38	20	20	83
VDI40.R105.20.01	40	38	20	20	83

State R or L version

Dimensions in mm

Further sizes upon request

For torque specification of the screw, please see Technical Instructions.

Spare Parts

Toolholder	Clamping Screw	TORX PLUS® Wrench
VDI16...	6.075T15P	T15PQ

Insert

U105

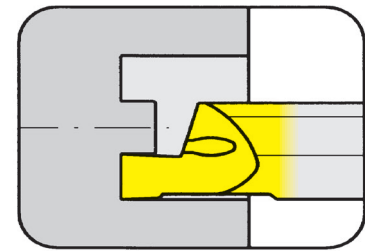

from outer groove \varnothing .315"
 Depth of groove .236"
 Width of groove up to .125"

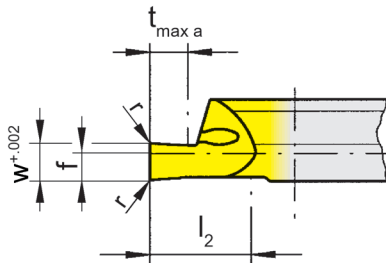
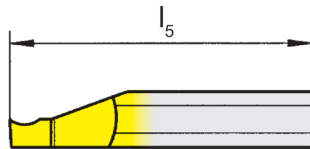

for Toolholder

Type H105
 HC105
 B105
 BU105
 VDI

R = right hand version shown

L = left hand version

Part number	w	r	f	b	l_2	l_5	$t_{max a}$	$D_{a min}$	TH35	T125
R/LU105.0846.1.8	.046	.006	.079	.276	.394	.984	.098	.315	▲/x	▲/▲
R/LU105.0862.1.8	.062	.006	.079	.276	.394	.984	.118	.315	▲/x	▲/▲
R/LU105.0878.1.8	.078	.006	.079	.276	.394	.984	.157	.315	▲/x	▲/▲
R/LU105.0894.1.8	.094	.006	.079	.276	.394	.984	.197	.315	▲/x	▲/▲
R/LU105.0812.1.8	.125	.006	.079	.276	.394	.984	.236	.315	▲/x	▲/▲
R/LU105.0846.2.8	.046	.006	.079	.276	.591	1.378	.098	.315	▲/x	▲/▲
R/LU105.0862.2.8	.062	.006	.079	.276	.591	1.378	.118	.315	▲/x	▲/▲
R/LU105.0878.2.8	.078	.006	.079	.276	.591	1.378	.157	.315	▲/x	▲/▲
R/LU105.0894.2.8	.094	.006	.079	.276	.591	1.378	.197	.315	▲/x	▲/▲
R/LU105.0812.2.8	.125	.006	.079	.276	.591	1.378	.236	.315	▲/x	▲/▲

▲ on stock Δ 4 weeks x upon request

● recommended

o alternative recommendation

- not suitable

□ uncoated grades

■ coated grades

■ brazed/Cermet

Dimensions in inch

State R or L version

	P	M	K	N	S	H
TH35	●	●	●	●	●	-
T125	●	●	●	●	●	-

Carbide grades

Insert

105

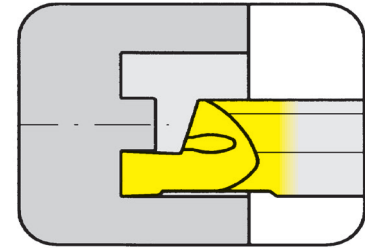

from outer groove \varnothing .197"
 Depth of groove .197"
 Width of groove up to .079"

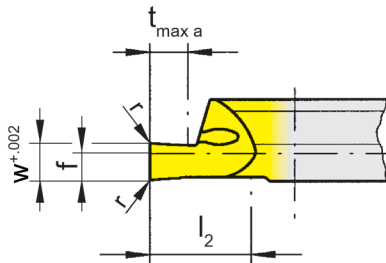
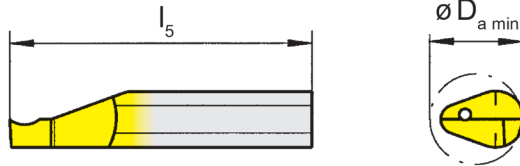

for Toolholder

Type H105
 HC105
 B105
 BU105
 VDI

R = right hand version shown

L = left hand version

Part number	w	r	f	b	l_2	l_5	$t_{max a}$	$D_{a min}$	MG12	AN25	EG35	ES15	TI25
R105.0505.1.8	.020	-	.079	.276	.394	.984	.079	.197		▲	△	▲	
R/L105.0510.1.8	.039	.002	.079	.276	.394	.984	.079	.197	▲/△		▲/▲		▲/▲
R/L105.0515.1.8	.059	.002	.079	.276	.394	.984	.118	.197	▲/△		▲/▲		▲/▲
R/L105.0520.1.8	.079	.002	.079	.276	.394	.984	.197	.197	▲/△		▲/▲		▲/▲
R/L105.0510.2.8	.039	.002	.079	.276	.591	1.378	.079	.197	△/x		▲/△		▲/▲
R/L105.0515.2.8	.059	.002	.079	.276	.591	1.378	.118	.197	△/x		▲/▲		▲/▲
R/L105.0520.2.8	.079	.002	.079	.276	.591	1.378	.197	.197	▲/▲		▲/▲		▲/▲

▲ on stock △ 4 weeks x upon request

● recommended

o alternative recommendation

- not suitable

■ uncoated grades

■ coated grades

■ brazed/Cermet

Dimensions in inch

State R or L version

P	o	●	●	●	●
M	-	o	●	o	●
K	-	-	o	●	●
N	-	-	-	-	●
S	-	-	-	-	●
H	-	-	-	-	-

Carbide grades

Face Grooving



Insert

105

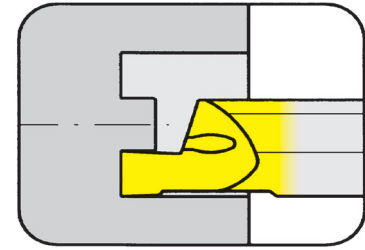

from outer groove \varnothing .236"
 Depth of groove .197"
 Width of groove up to .079"

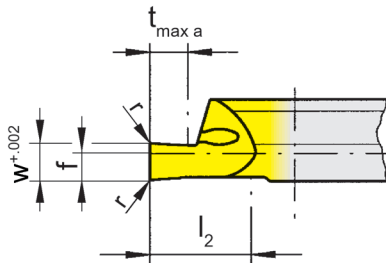
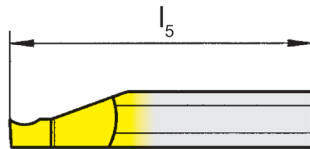

for Toolholder

Type H105
 HC105
 B105
 BU105
 VDI

R = right hand version shown

L = left hand version

Part number	w	r	f	b	l_2	l_5	$t_{max a}$	$D_{a min}$	MG12	EG35	TI25
R/L105.0610.1.8	.039	.002	.079	.276	.394	.984	.079	.236	▲/▲	▲/▲	▲/▲
R/L105.0615.1.8	.059	.002	.079	.276	.394	.984	.118	.236	Δ/Δ	▲/▲	▲/▲
R/L105.0620.1.8	.079	.002	.079	.276	.394	.984	.197	.236	▲/Δ	▲/▲	▲/▲
R/L105.0610.2.8	.039	.002	.079	.276	.591	1.378	.079	.236	Δ/Δ	▲/Δ	Δ/Δ
R/L105.0615.2.8	.059	.002	.079	.276	.591	1.378	.118	.236	Δ/x	▲/Δ	▲/Δ
R/L105.0620.2.8	.079	.002	.079	.276	.591	1.378	.197	.236	Δ/Δ	▲/▲	▲/▲
									P	○	●
									M	-	●
									K	-	○
									N	-	-
									S	-	-
									H	-	-

State R or L version

▲ on stock Δ 4 weeks x upon request

● recommended
 ○ alternative recommendation
 - not suitable

uncoated grades

coated grades

brazed/Cermet

Dimensions in inch

Carbide grades



Insert

105

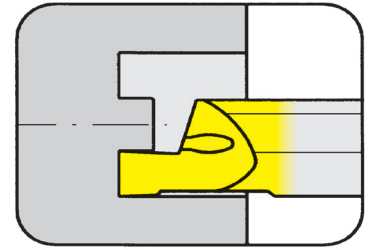

from outer groove \varnothing .315"
 Depth of groove .236"
 Width of groove up to .118"

for Toolholder

Type H105
 HC105
 B105
 BU105
 VDI

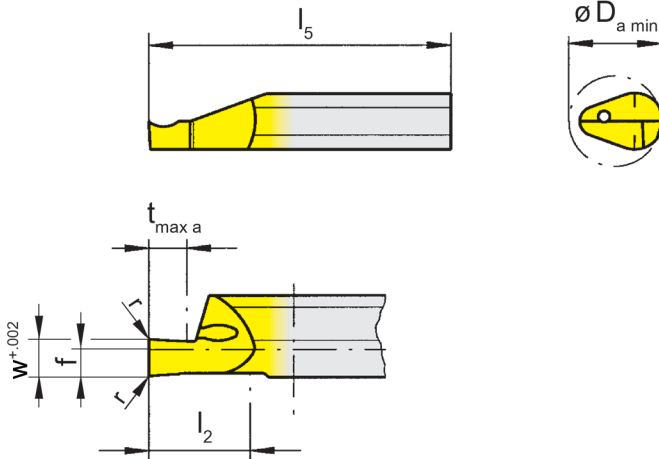

R = right hand version shown

L = left hand version

Part number	w	r	f	b	l_2	l_5	$t_{max a}$	$D_{a min}$	EG35	T125
R/L105.0810.1.8	.039	.006	.079	.276	.394	.984	.079	.315	▲/▲	▲/▲
R/L105.0815.1.8	.059	.006	.079	.276	.394	.984	.118	.315	▲/▲	▲/▲
R/L105.0820.1.8	.079	.006	.079	.276	.394	.984	.157	.315	▲/▲	▲/▲
R/L105.0825.1.8	.098	.006	.079	.276	.394	.984	.197	.315	▲/▲	▲/▲
R/L105.0830.1.8	.118	.006	.079	.276	.394	.984	.236	.315	▲/▲	▲/▲
R/L105.0810.2.8	.039	.006	.079	.276	.591	1.378	.079	.315	▲/▲	▲/▲
R/L105.0815.2.8	.059	.006	.079	.276	.591	1.378	.118	.315	▲/▲	▲/▲
R/L105.0820.2.8	.079	.006	.079	.276	.591	1.378	.157	.315	▲/▲	▲/▲
R/L105.0825.2.8	.098	.006	.079	.276	.591	1.378	.197	.315	▲/▲	▲/▲
R/L105.0830.2.8	.118	.006	.079	.276	.591	1.378	.236	.315	▲/▲	▲/▲

▲ on stock Δ 4 weeks x upon request

● recommended
 ○ alternative recommendation
 - not suitable

■ uncoated grades
 ■ coated grades
 ■ brazed/Cermet

Dimensions in inch

State R or L version

	P	M	K	N	S	H
EG35	●	●	○	-	-	-
T125	●	●	●	●	●	-

Carbide grades

Insert

105

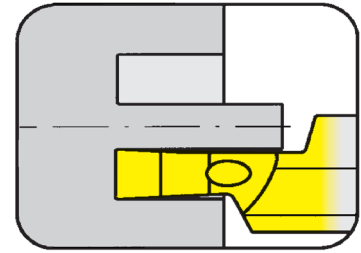

from outer groove \varnothing .315"
 Depth of groove .236"
 Width of groove up to .118"

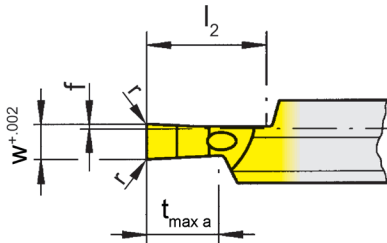
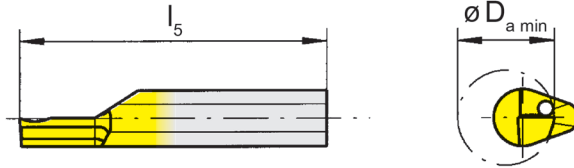

for Toolholder

Type H105
 HC105
 B105
 BU105
 VDI

R = right hand version shown

L = left hand version

Part number	w	r	f	b	l_2	l_5	$t_{max a}$	$D_{a min}$	EG35	T125
R/L105.0810.1.9	.039	.006	.016	.276	.394	.984	.079	.315	▲/▲	▲/▲
R/L105.0815.1.9	.059	.006	.016	.276	.394	.984	.118	.315	▲/▲	▲/▲
R/L105.0820.1.9	.079	.006	.016	.276	.394	.984	.157	.315	▲/▲	▲/▲
R/L105.0825.1.9	.098	.006	.016	.276	.394	.984	.197	.315	▲/▲	▲/▲
R/L105.0830.1.9	.118	.006	.016	.276	.394	.984	.236	.315	▲/▲	▲/▲

▲ on stock Δ 4 weeks x upon request

● recommended
 ○ alternative recommendation
 - not suitable

□ uncoated grades
 ■ coated grades
 ■ brazed/Cermet

Dimensions in inch

State R or L version

	P	M	K	N	S	H
EG35	●	●	○	-	-	-
T125	●	●	●	●	●	-

Carbide grades



Insert

U105

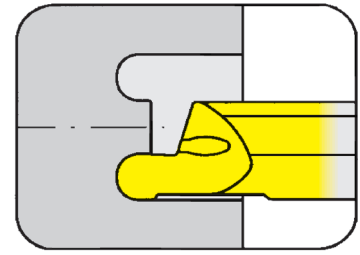

from outer groove \varnothing
Depth of groove
Width of groove up to

.315"
.236"
.125"

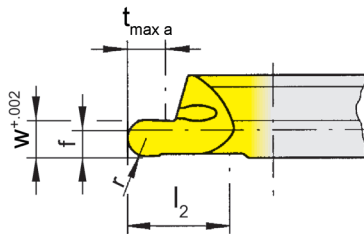
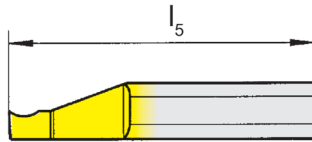

for Insert

Type H105
HC105
B105
BU105
VDI

Full radius

R = right hand version shown

L = left hand version

Part number	w	r	b	l ₂	l ₅	t _{max a}	TH35	T125
RU105.FF12.2.8	.125	.063	.276	.591	1.378	.236	▲	▲
RU105.FF46.2.8	.046	.023	.276	.591	1.378	.098	▲	▲
R/LU105.FF62.1.8	.062	.031	.276	.394	.984	.118	▲/x	▲/▲
RU105.FF62.2.8	.062	.031	.276	.591	1.378	.118	▲	▲
R/LU105.FF78.1.8	.078	.039	.276	.394	.984	.157	▲/x	▲/▲
RU105.FF78.2.8	.078	.039	.276	.591	1.378	.157	▲	▲
RU105.FF94.1.8	.094	.047	.276	.394	.984	.197	▲	▲
RU105.FF94.2.8	.094	.047	.276	.591	1.378	.197	▲	▲
R/LU105.FF12.1.8	.125	.063	.276	.394	.984	.236	▲/x	▲/▲
RU105.FF12.2.8	.125	.063	.276	.591	1.378	.236	▲	▲
R/LU105.FF46.1.8	.046	.023	.276	.394	.984	.098	▲/x	▲/▲
RU105.FF46.2.8	.046	.023	.276	.591	1.378	.098	▲	▲
R/LU105.FF62.1.8	.062	.031	.276	.394	.984	.118	▲/x	▲/▲
RU105.FF62.2.8	.062	.031	.276	.591	1.378	.118	▲	▲
RU105.FF78.2.8	.078	.039	.276	.591	1.378	.157	▲	▲
RU105.FF94.2.8	.094	.047	.276	.591	1.378	.197	▲	▲

▲ on stock Δ 4 weeks x upon request

● recommended

○ alternative recommendation

- not suitable

■ uncoated grades

■ coated grades

■ brazed/Cermet

Dimensions in inch

State R or L version

	TH35	T125
P	●	●
M	●	●
K	●	●
N	●	●
S	●	●
H	-	-

Carbide grades

Face Grooving



Insert

105

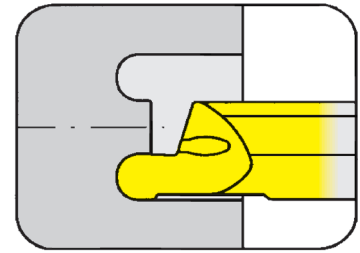

from outer groove \varnothing
Depth of groove
Width of groove up to

.315"
.236"
.118"

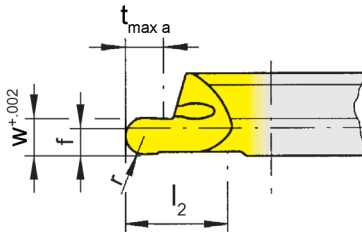
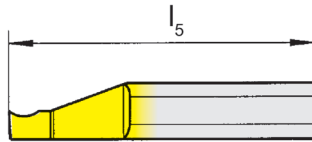

for Toolholder

Type H105
HC105
B105
BU105
VDI

Full radius

R = right hand version shown

L = left hand version

Part number	w	r	f	b	l_2	l_5	$t_{max a}$	$D_{a min}$	EG35	T125
R/L105.8V10.1.8	.039	.020	.079	.276	.394	.984	.079	.315	▲/▲	▲/▲
R/L105.8V16.1.8	.063	.031	.079	.276	.394	.984	.118	.315	▲/▲	▲/▲
R/L105.8V20.1.8	.079	.039	.079	.276	.394	.984	.157	.315	▲/▲	▲/▲
R/L105.8V25.1.8	.098	.049	.079	.276	.394	.984	.197	.315	▲/Δ	▲/▲
R/L105.8V30.1.8	.118	.059	.079	.276	.394	.984	.236	.315	▲/▲	▲/▲
R/L105.8V10.2.8	.039	.020	.079	.276	.591	1.378	.079	.315	▲/▲	▲/▲
R/L105.8V16.2.8	.063	.031	.079	.276	.591	1.378	.118	.315	▲/Δ	▲/▲
R/L105.8V20.2.8	.079	.039	.079	.276	.591	1.378	.157	.315	▲/▲	▲/▲
R/L105.8V25.2.8	.098	.049	.079	.276	.591	1.378	.197	.315	▲/Δ	▲/Δ
R/L105.8V30.2.8	.118	.059	.079	.276	.591	1.378	.236	.315	▲/Δ	▲/▲

▲ on stock Δ 4 weeks x upon request

● recommended
○ alternative recommendation
- not suitable

■ uncoated grades
■ coated grades
■ brazed/Cermet

Dimensions in inch

State R or L version

	P	M	K	N	S	H
EG35	●	●	○	-	-	-
T125	●	●	●	●	●	-

Carbide grades

Toolholder

BU105

with through coolant supply

Bore Ø from	.394"
Depth of groove	.591"
Width of groove	.118"

Extended depth of insert seat

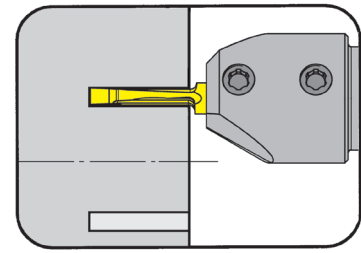

for Insert

Type A105...2.2

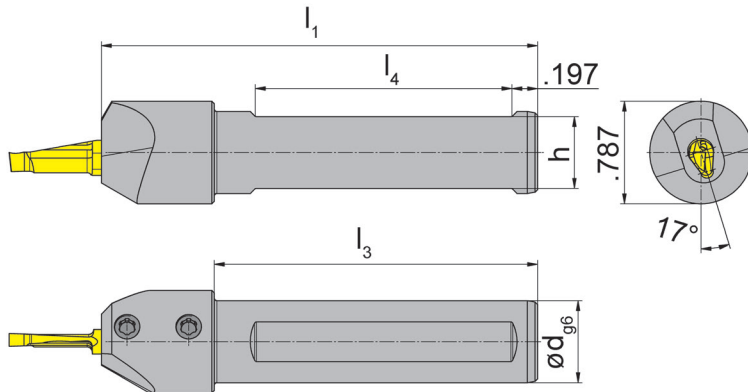

Picture = right hand cutting version

Part number	d	l ₁	h	l ₄
R/LBU105.0625.12.2	.625	3.346	.546	1.969
R/LBU105.0750.12.2	.750	3.937	.671	2.165
R/LBU105.1000.12.2	1.000	3.937	.921	2.165

State R or L version

Dimensions in inch

Further sizes upon request

Ordering note:

Toolholders can be used with right and left hand inserts.

For torque specification of the screw, please see Technical Instructions.

Spare Parts

Toolholder	Clamping Screw	TORX PLUS® Wrench
R/LBU105...	6.075T15P	T15PQ

Toolholder

B105

with through coolant supply

from outer groove \varnothing 10 mm
 Depth of groove 15 mm
 Width of groove 2-3 mm

Extended depth of insert seat

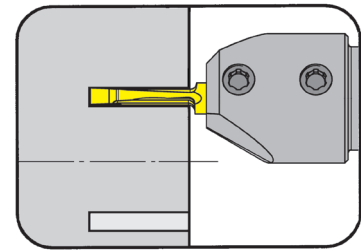

for Insert

Type A105...2.2

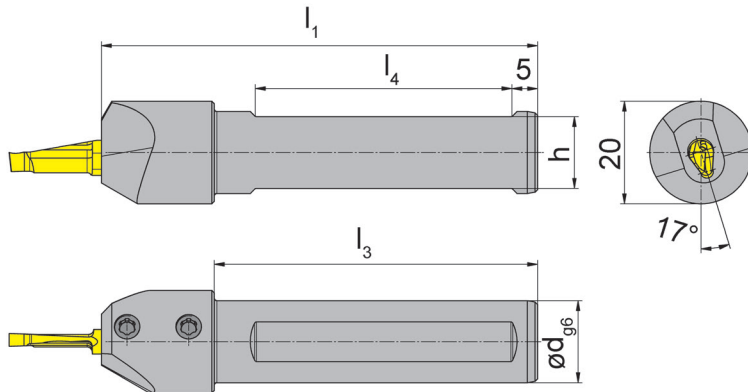

L = left hand version shown

R = right hand version

Part number	d	l ₁	l ₃	h	l ₄
R/LB105.0016.12.2	16	85	63	14	50
R/LB105.0020.12.2	20	100	-	18	55

State R or L version

Dimensions in mm

Further sizes upon request

For torque specification of the screw, please see Technical Instructions.

Spare Parts

Toolholder	Clamping Screw	TORX PLUS® Wrench
R/LB105...	6.075T15P	T15PQ



Insert

A105

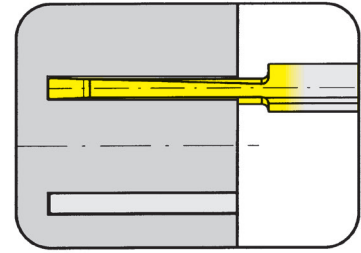

from outer groove \varnothing	.394"
Depth of groove	.591"
Width of groove	.079-.118"

for Toolholder

Type B105...12.2

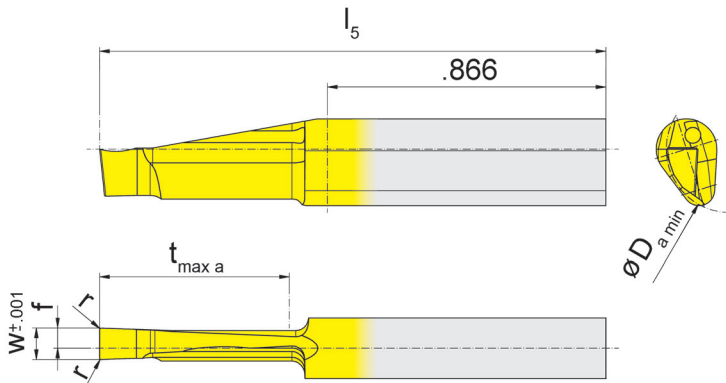

L = left hand version shown

R = right hand version

Part number	w	r	f	l_5	$t_{max a}$	$D_{a min}$	EG35	T125
R/LA105.1020.2.2	.079	.004	.055	1.575	.591	.394	▲/▲	▲/▲
R/LA105.1025.2.2	.098	.004	.063	1.575	.591	.394	▲/▲	▲/▲
R/LA105.1030.2.2	.118	.004	.039	1.575	.591	.394	▲/▲	▲/▲
							P	•
							M	•
							K	•
							N	-
							S	-
							H	-

- ▲ on stock Δ 4 weeks x upon request
- recommended
- o alternative recommendation
- not suitable
- uncoated grades
- coated grades
- brazed/Cermet

Dimensions in inch

State R or L version

Note:

Use insert RA105 in toolholder RB105...12.2 and insert LA105 in toolholder LB105...12.2.

Face grooving with full width of the full depth only possible between D_{amin} .394" - 1.575"!

Carbide grades



Toolholder

B110

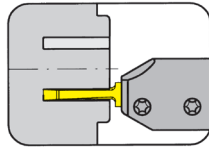

Page
T22-T23

Insert

A110

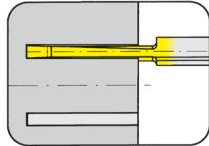

Page
T24

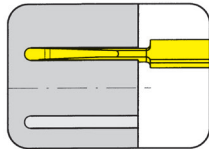

Page
T25



110



T

Toolholder with Inserts

Width of groove .118"

Toolholder

BU110

with through coolant supply

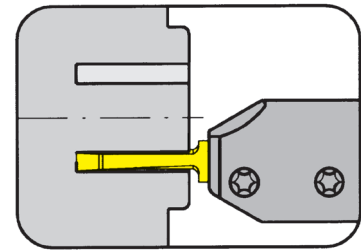

from outer groove \varnothing
Depth of groove
Width of groove up to

.787"
1.181"
.118"

Extended depth of insert seat

for Insert

Type A110

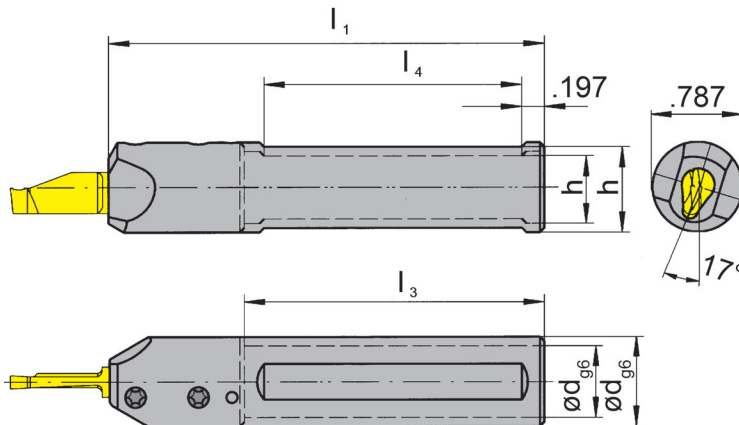

R = right hand version shown

L = left hand version

Part number	d	l_1	l_3	h	l_4
R/LBU110.0625.16.2	.625	3.397	2.756	.551	2.165
R/LBU110.0750.16.2	.750	3.397	-	.709	2.165

State R or L version

Dimensions in inch

Further sizes upon request

For torque specification of the screw, please see Technical Instructions.

Spare Parts

Toolholder	Clamping Screw	TORX PLUS® Wrench
R/LB110...	6.075T15P	T15PQ

Toolholder

B110

with through coolant supply

from outer groove \varnothing
Depth of groove
Width of groove up to

20 mm
30 mm
3 mm

Extended depth of insert seat

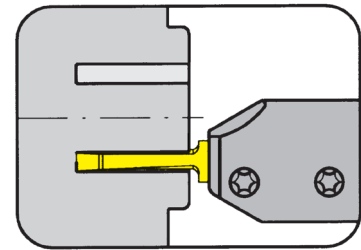

for Insert

Type A110

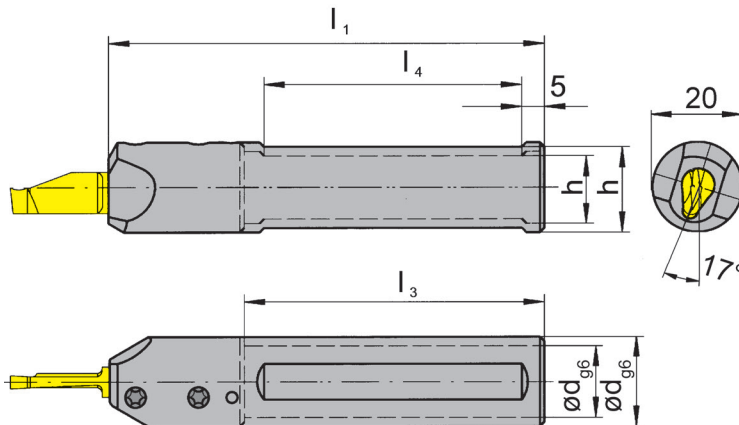

R = right hand version shown

L = left hand version

Part number	d	l_1	l_3	h	l_4
R/LB110.0016.16.2	16	100	70	14	55
R/LB110.0020.16.2	20	100	-	18	55

State R or L version

Dimensions in mm

Further sizes upon request

For torque specification of the screw, please see Technical Instructions.

Spare Parts

Toolholder	Clamping Screw	TORX PLUS® Wrench
R/LB110...	6.075T15P	T15PQ

Insert

A110

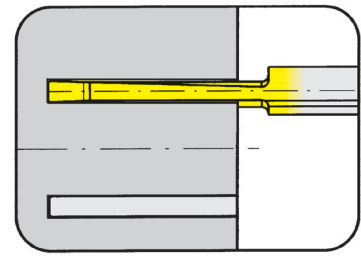

from outer groove \varnothing	.787"
Depth of groove	.787 - 1.181"
Width of groove	.118"

for Toolholder

Type B110...16.2
BU110...16.2

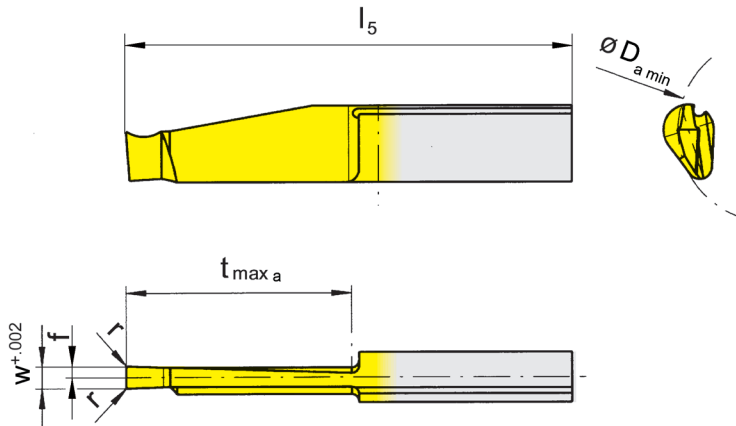

L = left hand version shown

R = right hand version

Part number	w	r	f	l ₅	t _{max a}	D _{a min}	Carbide grades				
							EG35	TH35	TI25	TN35	
R/LA110.2030.3.0	.118	.008	.059	1.969	.787	.787	▲▲	▲/▲	▲/▲	▲▲	
R/LA110.2030.5.0	.118	.008	.059	2.362	1.181	.787	▲▲	▲/▲	▲/▲	▲▲	
R/LA110.5030.3.0	.118	.008	.059	1.969	.787	1.969	▲▲		▲/▲		
R/LA110.5030.5.0	.118	.008	.059	2.362	1.181	1.969	▲▲		▲/▲		
							P	•	•	•	•
							M	•	•	•	•
							K	○	•	•	•
							N	-	•	•	•
							S	-	•	•	•
							H	-	-	-	-

▲ on stock Δ 4 weeks x upon request

- recommended
- alternative recommendation
- not suitable

- uncoated grades
- coated grades
- brazed/Cermet

Dimensions in inch

State R or L version

Note:

Use insert RA110 in toolholder RB110...16.2 and insert LA110 in toolholder LB110...16.2.

Face grooving with full width of the full depth only possible between D_{amin} .787" - 1.969".

Insert

A110

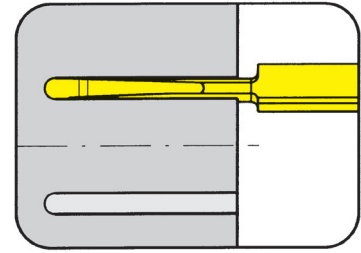

from outer groove \emptyset	.787"
Depth of groove	1.181"
Width of groove	.118"

for Toolholder

Type B110...16.2
BU110...16.2

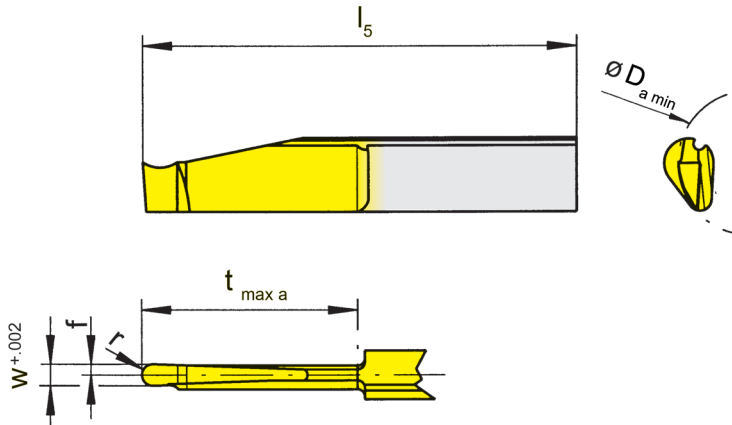

L = left hand version shown

R = right hand version

Full radius

Part number	w	r	f	l_5	$t_{max a}$	$D_{a min}$		EG35	TN35
R/LA110.2030.15.5.0	.118	.059	.059	2.362	1.181	.787		▲/▲	▲/▲
								P	•
								M	•
								K	•
								N	•
								S	•
								H	-

- ▲ on stock Δ 4 weeks x upon request
 - recommended
 - o alternative recommendation
 - not suitable
 - uncoated grades
 - coated grades
 - brazed/Cermet
- Dimensions in inch

Carbide grades

State R or L version

Note:

Use insert RA110 in toolholder RB110...16.2 and insert LA110 in toolholder LB110...16.2.

Face grooving with full width of the full depth only possible between $D_{a min}$.787 - 1.969".



Toolholder
B114

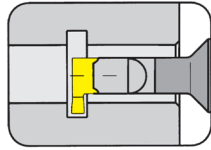

Page
T28-T29

Toolholder
HC114

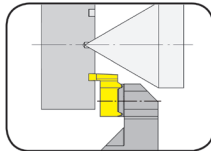

Page
T34-T35

Toolholder
B114/RBA114

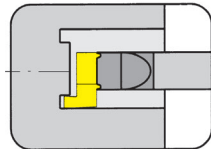

Page
T3

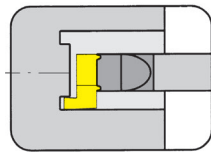

Page
T36-T37

Insert
U114/BU114/114

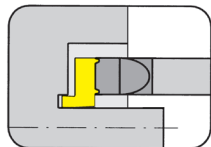

Page
T38-T39

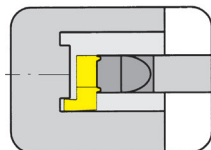

Page
T38-T39

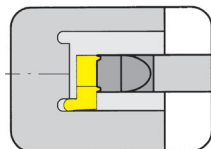

Page
T40-T41

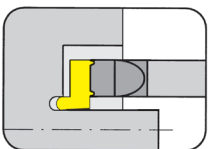

Page
T42-T43

T

114



T

Toolholder with Inserts

Width of groove .039 - .118"

Toolholder

BU114

with through coolant supply

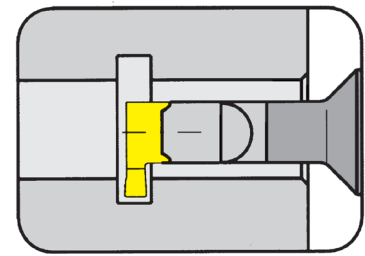

Depth of bore up to 2.520"
 Depth of groove up to .256"
 Width of groove .125"

Material of shank: Carbide - Giving a good vibration resistance

for Insert

Type 114
 U114

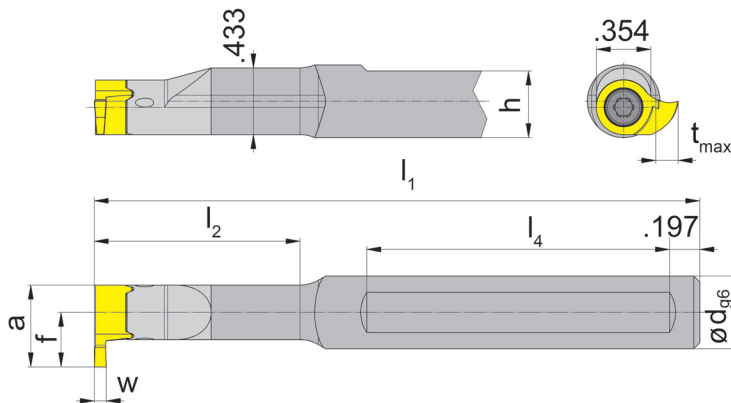

Picture = right hand cutting version

Part number	d	l ₁	l ₂	h	l ₄
BU114.0500.01	.500	3.937	1.339	.461	1.969
BU114.0500.02	.500	4.331	1.772	.461	1.969
BU114.0500.03	.500	5.118	2.520	.461	1.969
BU114.0625.01	.625	3.937	1.339	.585	1.969
BU114.0625.02	.625	4.331	1.772	.585	1.969
BU114.0625.03	.625	5.118	2.520	.585	1.969
BU114.ST05.00	.500	2.953	.748	.460	1.571
BU114.ST06.00	.625	3.150	.748	.585	1.571

Further sizes upon request

w, a, s, t_{max} and f see inserts

Dimensions in inch

Ordering note:

Toolholders can be used with right and left hand inserts. Toolholders with damaged seating can be repaired by HORN.

For torque specification of the screw, please see Technical Instructions.

Steel toolholder denoted BU114.ST...

* Steel toolholder is not repairable.

Spare Parts

Toolholder	Clamping Screw	TORX PLUS® Wrench
BU114....	4.12T15EP	T15PQ

Toolholder

B114

with through coolant supply

Depth of bore up to
Depth of groove up to
Width of groove

64 mm
6 mm
1 - 3 mm

Material of shank: Carbide - Giving a good vibration resistance

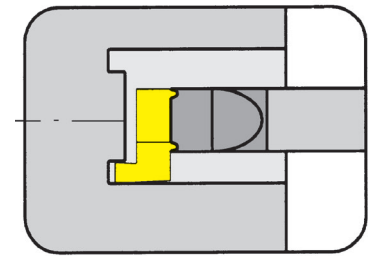

for Insert

Type 114
U114

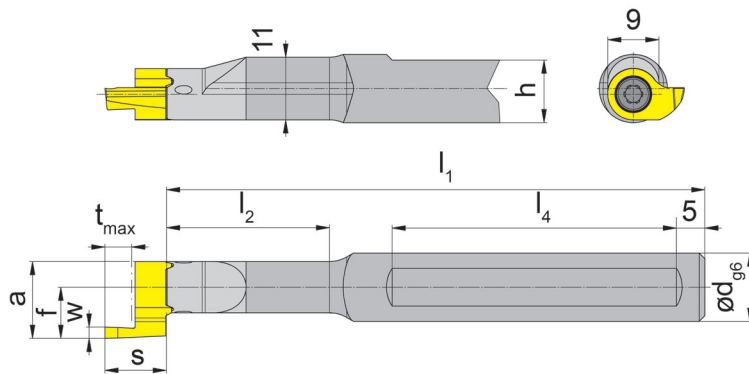

Picture = right hand cutting version

Part number	d	l_1	l_2	h	l_4
B114.0012.00	12	69.7	14.2	11	40
B114.0012.01	12	94.7	28.7	11	50
B114.0012.02	12	104.7	39.7	11	50
B114.0012.03	12	124.7	58.7	11	50
B114.0016.00	16	74.7	14.2	15	40
B114.0016.01	16	94.7	28.7	15	50
B114.0016.02	16	104.7	39.7	15	50
B114.0016.03	16	124.7	58.7	15	50

Further sizes upon request

w, a, s, t_{max} and f see inserts

Dimensions in mm

Ordering note:

Toolholders can be used with right and left hand inserts. Toolholders with damaged seating can be repaired by HORN.

For torque specification of the screw, please see Technical Instructions.

Spare Parts

Toolholder	Clamping Screw	TORX PLUS® Wrench
B114...	4.12T15EP	T15PQ

Toolholder

B114

with through coolant supply

Depth of bore up to
Depth of groove up to
Width of groove

64 mm
6 mm
1-3 mm

Material of shank: Carbide - Giving a good vibration resistance

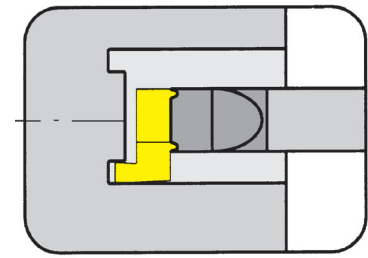

for Insert

Type 114
U114

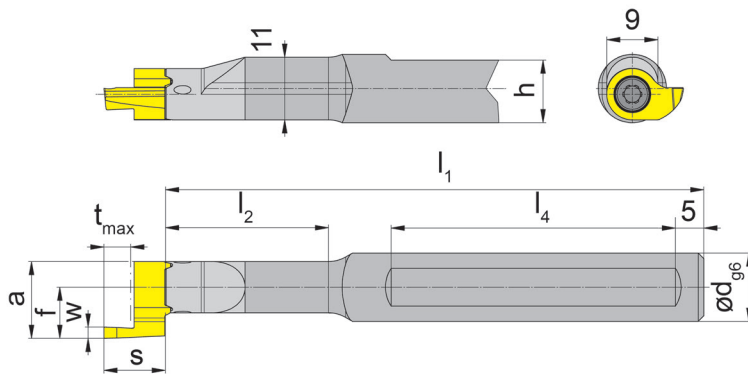

with 2 clamping flats

Picture = right hand cutting version

Part number	d	l ₁	l ₂	h	l ₄
B114.0012.2.00	12	69.7	19.5	11	40
B114.0012.2.01	12	94.7	34.0	11	50
B114.0012.2.02	12	104.7	45.0	11	50
B114.0012.2.03	12	124.7	64.0	11	50
B114.0016.2.00	16	74.7	19.5	14	40
B114.0016.2.01	16	94.7	34.0	14	50
B114.0016.2.02	16	104.7	45.0	14	50
B114.0016.2.03	16	124.7	64.0	14	50

Further sizes upon request

w, a, s, t_{max} and f see inserts

Dimensions in mm

Ordering note:

Toolholders can be used with right and left hand inserts. Toolholders with damaged seating can be repaired by HORN.

For torque specification of the screw, please see Technical Instructions.

Spare Parts

Toolholder	Clamping Screw	TORX PLUS® Wrench
B114...	4.12T15EP	T15PQ

Toolholder

RBAU114

with through coolant supply

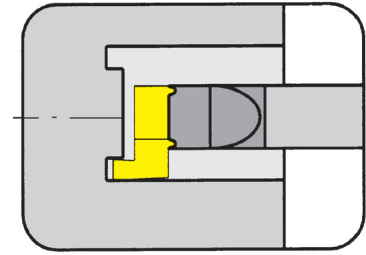

Bore Ø	.551"
Depth of groove	.236"
Width of groove up to	.118"

Material of shank: Carbide - Giving a good vibration resistance

for Insert

Type 114
U114

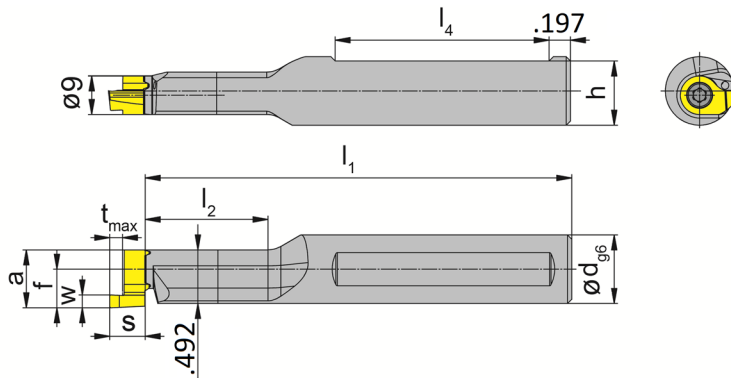

Picture = right hand cutting version

Part number	d	l ₁	l ₂	h	l ₄
RBAU114.0625.01	.625	3.925	1.130	.586	1.969
RBAU114.0625.02	.625	4.319	1.563	.586	1.969

Further sizes upon request

w, a, s, t_{max} and f see inserts

Dimensions in inch

Ordering note:

Toolholders with damaged seating can be repaired by HORN.

For torque specification of the screw, please see Technical Instructions.

Spare Parts

Toolholder	Clamping Screw	TORX PLUS® Wrench
RBAU114...	4.12T15EP	T15PQ



Toolholder

RBA114

with through coolant supply

Bore Ø	14 mm
Depth of groove	6 mm
Width of groove up to	3 mm

Material of shank: Carbide - Giving a good vibration resistance

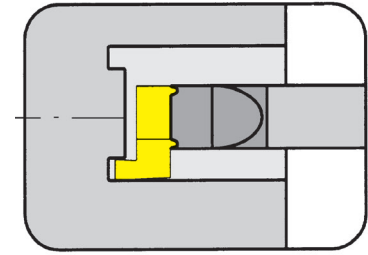

for Insert

Type 114
U114

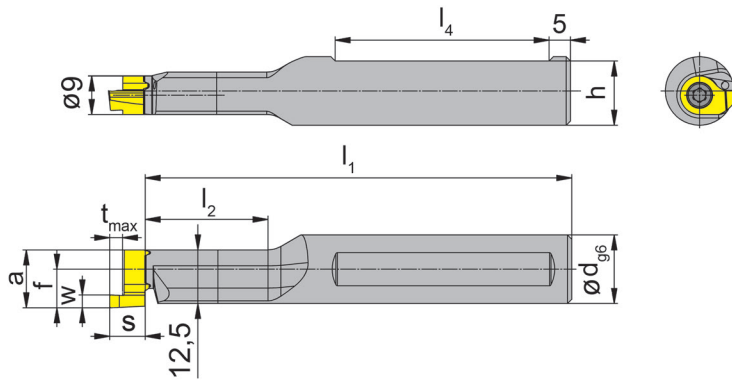

Picture = right hand cutting version

Part number	d	l ₁	l ₂	h	l ₄
RBA114.0016.01	16	99.7	28.7	15	50
RBA114.0016.02	16	109.7	39.7	15	50

Further sizes upon request

w, a, s, t_{max} and f see inserts

Dimensions in mm

Ordering note:

Toolholders with damaged seating can be repaired by HORN.

For torque specification of the screw, please see Technical Instructions.

Spare Parts

Toolholder	Clamping Screw	TORX PLUS® Wrench
RBA114...	4.12T15EP	T15PQ

Toolholder

B114

with through coolant supply

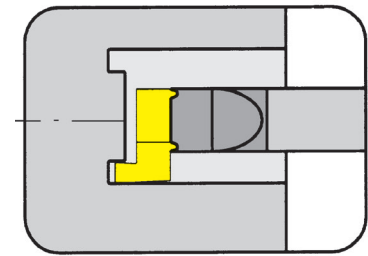

Bore Ø from
Depth of groove up to
Width of groove

14 mm
6 mm
1-3 mm

Material of shank: Carbide - Giving a good vibration resistance

for Insert

Type 114
U114

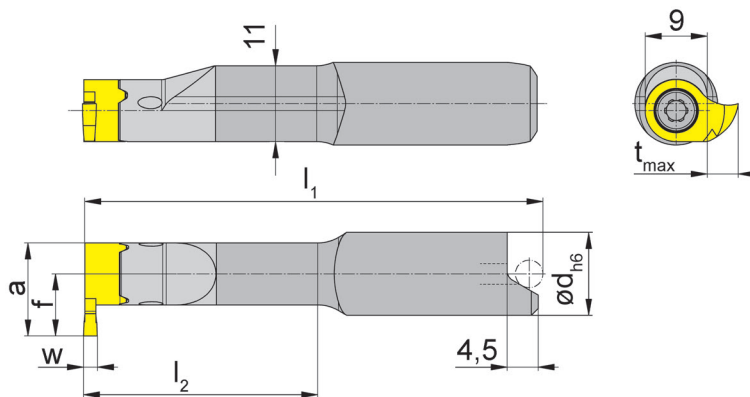

Picture = right hand cutting version

for shrinkage location

Part number	d	l ₁	l ₂
B114.0012.00S	12	47.4	14.2
B114.0012.01S	12	61.4	28.7
B114.0012.02S	12	72.4	39.7
B114.0012.03S	12	96.7	64.0

Further sizes upon request

w, a, s, t_{max} and f see inserts

Dimensions in mm

Ordering note:

Toolholders can be used with right and left hand inserts. Toolholders with damaged seating can be repaired by HORN.

For torque specification of the screw, please see Technical Instructions.

Spare Parts

Toolholder	Clamping Screw	TORX PLUS® Wrench
B114...	4.12T15EP	T15PQ

Toolholder

HCU114

from outer groove \varnothing
Depth of groove up to
Width of groove up to

.472"
.236"
.125"

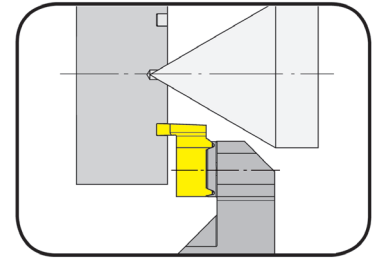

for Insert

Type 114
U114

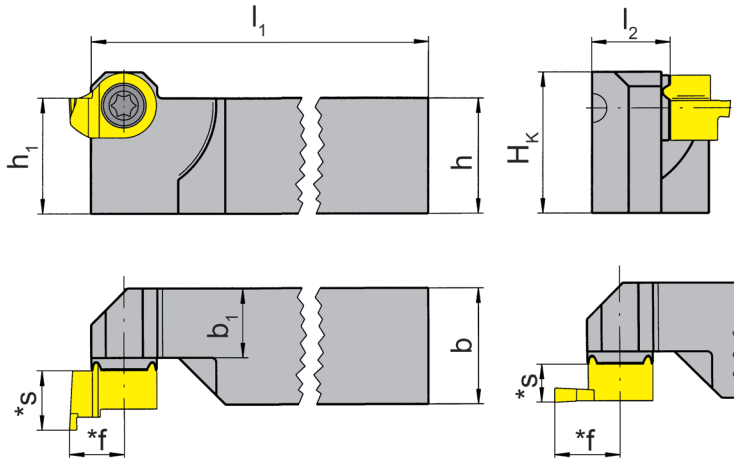

R = right hand version shown

L = left hand version

axial and radial

Part number	h	h ₁	l ₁	l ₂	b	b ₁	H _k
R/LHCU114.0500.01	.500	.500	3.819	.441	.500	.374	.642
R/LHCU114.0625.01	.625	.625	4.803	.441	.625	.374	.768
R/LHCU114.0750.01	.750	.750	4.803	.559	.750	.492	.894
R/LHCU114.1000.01	1.000	1.000	5.787	.815	1.000	.728	1.142

Further sizes upon request

* see inserts

Dimensions in inch

State R or L version

Ordering note:

Right hand toolholders use left hand inserts. Left hand toolholders use right hand inserts.

For torque specification of the screw, please see Technical Instructions.

Spare Parts

Toolholder	Clamping Screw	TORX PLUS® Wrench
R/LHCU114...	4.12T15EP	T15PQ

Toolholder

HC114

Depth of groove up to
Width of groove up to

6 mm
3 mm

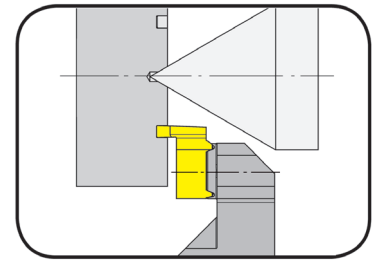

for Insert

Type 114
U114

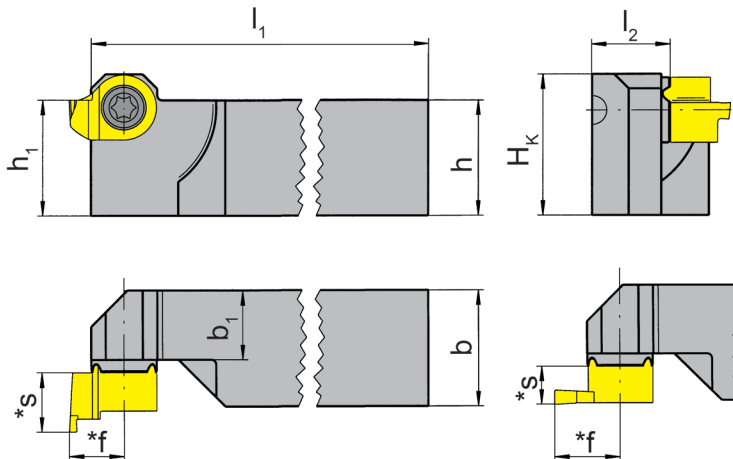

R = right hand version shown

L = left hand version

axial and radial

T

Part number	h	b	l ₁	l ₂	h ₁	b ₁	H _k
R/LHC114.1212.01	12	12	122	11.2	12	9.5	15.6
R/LHC114.1616.01	16	16	122	11.2	16	9.5	19.6
R/LHC114.2020.01	20	20	122	15.2	20	13.5	23.6
R/LHC114.2525.01	25	25	147	20.2	25	18.5	28.6

Further sizes upon request

* see inserts

Dimensions in mm

State R or L version

Ordering note:

Right hand toolholders use left hand inserts. Left hand toolholders use right hand inserts.

For torque specification of the screw, please see Technical Instructions.

Spare Parts

Toolholder	Clamping Screw	TORX PLUS® Wrench
R/LHC114...	4.12T15EP	T15PQ

Insert

U114

from outer groove \varnothing
 Depth of groove up to
 Width of groove

.472"
 .118"
 .046 - .125"

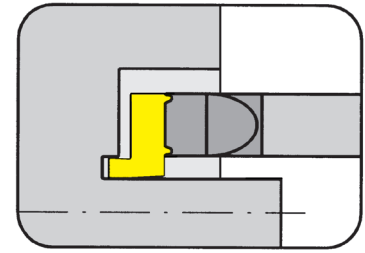

for Toolholder

Type B114
 BU114
 HC114
 HCU114

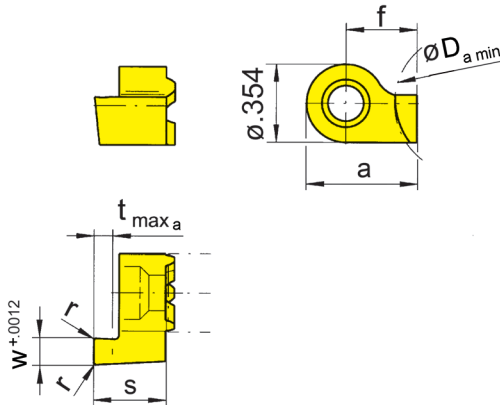

Machining **BEHIND**
 centerline

R = right hand version shown

L = left hand version

Part number	w	s	f	a	r	t _{max a}	D _{a min}	TH35	TN35
R/LU114.1225.00	.126	.327	.295	.472	.008	.118	.472	▲/x	▲/▲
R/LU114.1246.00	.047	.327	.295	.472	.008	.071	.472	▲/x	▲/▲
R/LU114.1262.00	.063	.327	.295	.472	.008	.098	.472	▲/x	▲/▲
R/LU114.1278.00	.079	.327	.295	.472	.008	.118	.472	▲/x	▲/▲
R/LU114.1294.00	.095	.327	.295	.472	.008	.118	.472	▲/x	▲/▲

▲ on stock Δ 4 weeks x upon request

● recommended

o alternative recommendation

- not suitable

□ uncoated grades

■ coated grades

■ brazed/Cermet

Dimensions in inch

State R or L version

Note:

R = rotation counter clockwise!

Using the face grooving insert type 114 on toolholder type B114 the size I1 and I2 will be extended by .327"

	P	M	K	N	S	H
TH35	●	●	●	●	●	-
TN35	●	●	●	●	●	-

Carbide grades

Insert

114

from outer groove \varnothing
Depth of groove up to
Width of groove

.472"
.236"
.039 - .118"

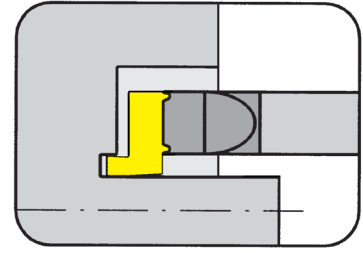

for Toolholder

Type B114
BU114
HC114
HCU114

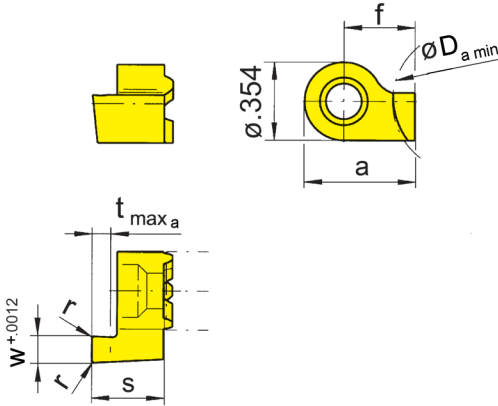

R = right hand version shown

L = left hand version

Machining **BEHIND**
centerline



Part number	w	s	f	a	r	t _{max a}	D _{a min}	EG55	TN35
R/L114.1210.00	.039	.327	.295	.472	-	.059	.472	▲▲	▲▲
R/L114.1215.00	.059	.327	.295	.472	.008	.098	.472	▲▲	▲▲
R/L114.1220.00	.079	.327	.295	.472	.008	.118	.472	▲▲	▲▲
R/L114.1225.00	.098	.327	.295	.472	.008	.118	.472	▲▲	▲▲
R/L114.1230.00	.118	.327	.295	.472	.008	.118	.472	▲▲	▲▲
R/L114.1220.5.00	.079	.425	.295	.472	.008	.197	.472	▲▲	▲▲
R/L114.1225.5.00	.098	.425	.295	.472	.008	.197	.472	▲▲	▲▲
R/L114.1230.6.00	.118	.465	.295	.472	.008	.236	.472	▲▲	▲▲

▲ on stock Δ 4 weeks x upon request
● recommended
○ alternative recommendation
- not suitable
■ uncoated grades
■ coated grades
■ brazed/Cermet
Dimensions in inch

	P	M	K	N	S	H
EG55	●	○	○	-	-	-
TN35	●	○	○	●	●	-

Carbide grades

State R or L version

Note:

R = rotation anti-clockwise!

Using the face grooving insert type 114 on toolholder type B114 the size I1 and I2 will be enlarged by .118, .217 or .256".

Insert

U114

from outer groove \varnothing
 Depth of groove up to
 Width of groove

.551"
 .118"
 .046 - .125"

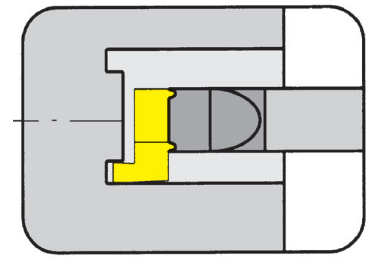

for Toolholder

Type B114
 BU114
 HC114
 HCU114

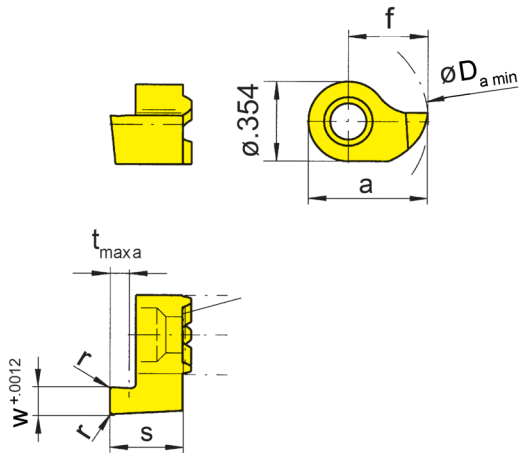

R = right hand version shown

L = left hand version

Machining **IN-FRONT**
 of centerline

Part number	w	s	f	a	r	t _{max a}	D _{a min}		TH35	TN35
R/LU114.1446.00	.047	.327	.354	.531	-	.059	.551		x/x	▲/▲
R/LU114.1462.00	.063	.327	.354	.531	.008	.098	.551		▲/x	▲/▲
R/LU114.1478.00	.079	.327	.354	.531	.008	.118	.551		▲/x	▲/▲
R/LU114.1494.00	.095	.327	.354	.531	.008	.118	.551		▲/x	▲/▲
R/LU114.1425.00	.126	.327	.354	.531	.008	.118	.551		▲/x	▲/▲

▲ on stock Δ 4 weeks x upon request

● recommended

o alternative recommendation

- not suitable

■ uncoated grades

■ coated grades

■ brazed/Cermet

Dimensions in inch

State R or L version

Note:

R = rotation clockwise!

Using the face grooving insert type 114 on toolholder type B114 the size I1 and I2 will be extended by .327"

P	•	•
M	•	•
K	•	•
N	•	•
S	•	•
H	-	-

Carbide grades

Insert

114

from outer groove \emptyset
Depth of groove up to
Width of groove

.551"
.236"
.039 - .118"

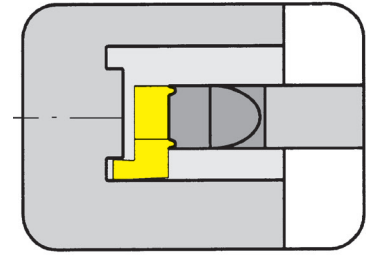

for Toolholder

Type B114
BU114
HC114
HCU114

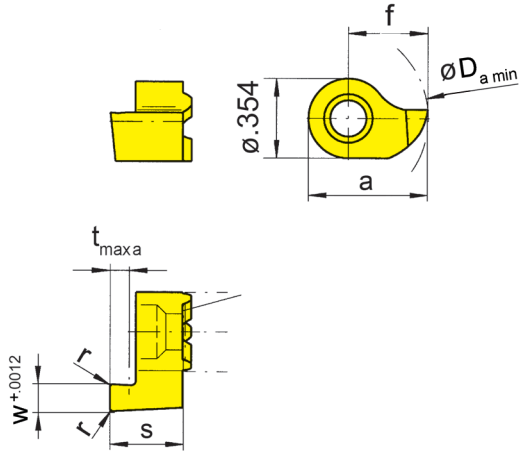

R = right hand version shown

L = left hand version

Machining **IN-FRONT** of
centre line



Part number	w	s	f	a	r	t _{max a}	D _{a min}	MG12	EG55	TF45	TN35
								▲/x	▲/▲	▲/x	▲/▲
R/L114.1410.00	.039	.327	.354	.531	-	.059	.551	▲/x	▲/▲		▲/▲
R/L114.1415.00	.059	.327	.354	.531	.008	.098	.551		▲/▲		▲/▲
R/L114.1420.00	.079	.327	.354	.531	.008	.118	.551		▲/▲	▲/x	▲/▲
R/L114.1425.00	.098	.327	.354	.531	.008	.118	.551		▲/▲		▲/▲
R/L114.1430.00	.118	.327	.354	.531	.008	.118	.551	▲/x	▲/▲		▲/▲
R/L114.1420.5.00	.079	.425	.354	.531	.008	.197	.551		▲/▲		▲/▲
R/L114.1425.5.00	.098	.425	.354	.531	.008	.197	.551		▲/▲		▲/▲
R/L114.1430.6.00	.118	.465	.354	.531	.008	.236	.551		▲/▲		▲/▲

- ▲ on stock Δ 4 weeks x upon request
- recommended
- o alternative recommendation
- not suitable
- uncoated grades
- coated grades
- brazed/Cermet

Dimensions in inch

State R or L version

Note:

R = rotation anti-clockwise!

P	o	•	•	•
M	-	o	•	•
K	-	o	•	•
N	-	-	•	•
S	-	-	•	•
H	-	-	-	-

Carbide grades

Using the face grooving insert type 114 on toolholder type B114 the size I1 and I2 will be enlarged by .118, .217 or .256".

Insert

U114

from outer groove \varnothing
 Depth of groove up to
 Depth of groove

.472"
 .118"
 .046 - .125"

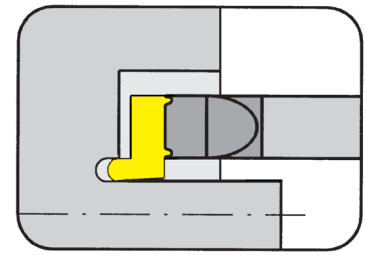

for Toolholder

Type B114
 BU114
 HC114
 HCU114

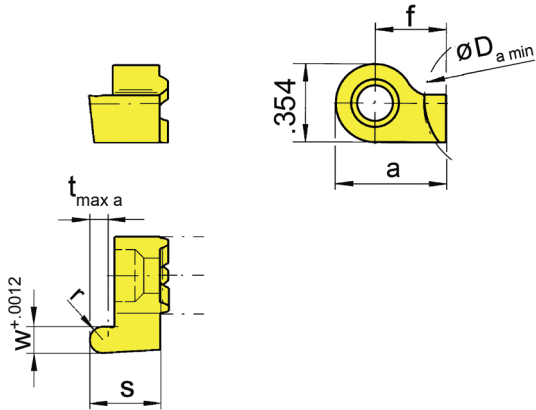

R = right hand version shown

L = left hand version

Full radius
 Machining **BEHIND**
 centerline

Part number	w	s	f	a	r	t _{max a}	D _{a min}		TH35	TN35
R/LU114.1223.46	.047	.327	.295	.472	.023	.059	.472		▲/x	▲/▲
R/LU114.1231.62	.063	.327	.295	.472	.032	.098	.472		▲/x	▲/▲
R/LU114.1239.78	.079	.327	.295	.472	.039	.118	.472		▲/x	▲/▲
R/LU114.1247.94	.095	.327	.295	.472	.047	.118	.472		▲/x	▲/▲

▲ on stock Δ 4 weeks x upon request

● recommended
 ○ alternative recommendation
 - not suitable

□ uncoated grades
 ■ coated grades
 ■ brazed/Cermet

Dimensions in inch

State R or L version

Note:

R = rotation counter clockwise!

Using the face grooving insert type 114 on toolholder type B114 the size I1 and I2 will be extended by .327"

	P	M	K	N	S	H
TH35	●	●	●	●	●	-
TN35	●	●	●	●	●	-

Carbide grades

Insert

114

from outer groove \varnothing
 Depth of groove up to
 Width of groove

.472"
 .236"
 .079 - .118"

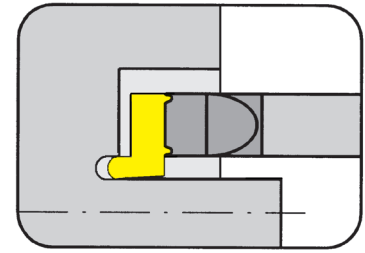

for Toolholder

Type B114
 BU114
 HC114
 HCU114

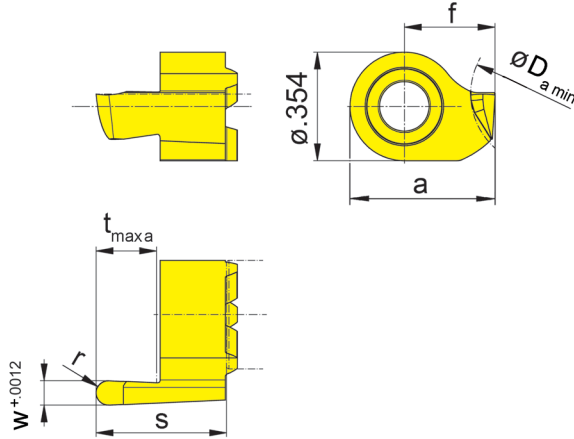

R = right hand version shown

L = left hand version

Full radius Machining
BEHIND centre line

Part number	w	s	f	a	r	t _{max a}	D _{a min}	EG55	TN35
R/L114.1220.5.10	.079	.425	.295	.472	.039	.197	.472	▲/▲	▲/▲
R/L114.1225.5.12	.098	.425	.295	.472	.049	.197	.472	▲/▲	▲/▲
R/L114.1230.6.15	.118	.465	.295	.472	.059	.236	.472	▲/▲	▲/▲

▲ on stock Δ 4 weeks x upon request

● recommended
 ○ alternative recommendation
 - not suitable

□ uncoated grades
 ■ coated grades
 ■ brazed/Cermet

Dimensions in inch

State R or L version

Note:

R = rotation counter clockwise!

	EG55	TN35
P	●	●
M	○	●
K	○	●
N	-	●
S	-	●
H	-	-

Carbide grades

Using the face grooving insert type 114 on toolholder type B114 the size I₁ and I₂ will be extended by .217" or .256".

Insert

U114

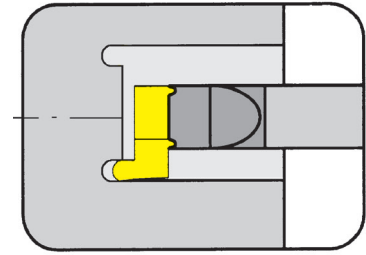

from outer groove \varnothing .551"
 Depth of groove up to .118"
 Width of groove .046 - .125"

for Toolholder

Type B114
 BU114
 HC114
 HCU114

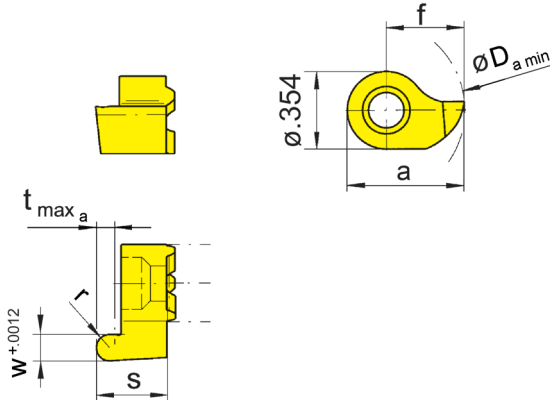

Full radius Machining
IN-FRONT of
 centerline

R = right hand version shown

L = left hand version

Part number	w	s	f	a	r	t _{max a}	D _{a min}		TH35	TN35
RU114.1423.46	.046	.327	.354	.531	.023	.059	.551		▲	▲
R/LU114.1431.62	.063	.327	.354	.531	.031	.098	.551		▲/x	▲/▲
R/LU114.1439.78	.078	.327	.354	.531	.039	.118	.551		x/x	▲/▲
R/LU114.1447.94	.094	.327	.354	.531	.047	.118	.551		▲/x	▲/▲
R/LU114.1462.12	.125	.327	.354	.531	.063	.118	.551		▲/x	▲/▲

▲ on stock Δ 4 weeks x upon request
 ● recommended
 ○ alternative recommendation
 - not suitable
 □ uncoated grades
 ■ coated grades
 ■ brazed/Cermet

	TH35	TN35
P	●	●
M	●	●
K	●	●
N	●	●
S	●	●
H	-	-

Dimensions in inch

Carbide grades

State R or L version

Note:

R = rotation clockwise!

Using the face grooving insert type 114 on toolholder type B114 the size I1 and I2 will be extended by .327"

Insert

114

from outer groove \emptyset
Depth of groove up to
Width of groove

.551"
.118"
.039 - .118"

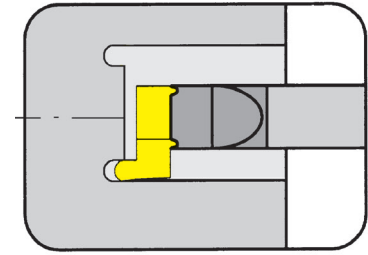

for Toolholder

Type B114
BU114
HC114
HCU114

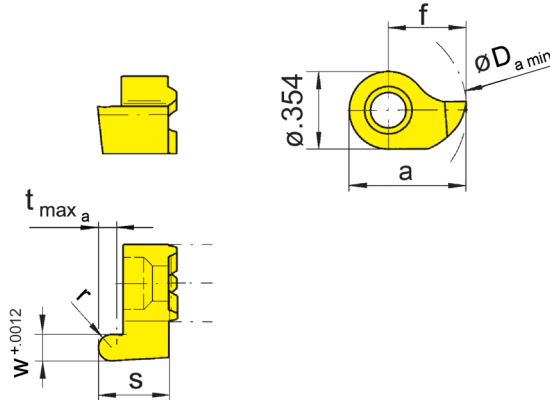

R = right hand version shown

L = left hand version

Full radius Machining
IN-FRONT of
centerline

Part number	w	s	f	a	r	t _{max a}	D _{a min}	EG55	TN35
R/L114.1410.05	.039	.327	.354	.531	.020	.059	.551	▲/▲	▲/▲
R/L114.1416.08	.063	.327	.354	.531	.031	.098	.551	▲/▲	▲/▲
R/L114.1420.10	.079	.327	.354	.531	.039	.118	.551	▲/▲	▲/▲
R/L114.1425.12	.098	.327	.354	.531	.049	.118	.551	▲/▲	▲/▲
R/L114.1430.15	.118	.327	.354	.531	.059	.118	.551	▲/▲	▲/▲

▲ on stock Δ 4 weeks x upon request

● recommended

○ alternative recommendation

- not suitable

□ uncoated grades

■ coated grades

■ brazed/Cermet

Dimensions in inch

State R or L version

Note:

R = rotation clockwise!

	EG55	TN35
P	●	●
M	○	●
K	○	●
N	-	●
S	-	●
H	-	-

Carbide grades

Using the face grooving insert type 114 on toolholder type B114 the size I1 and I2 will be enlarged by .118".

Toolholder
H25A/IB25A

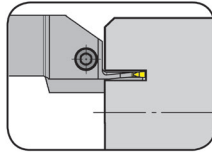

Page
T46

Cassette
K25A

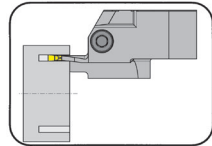

Page
T47

Insert
S15A

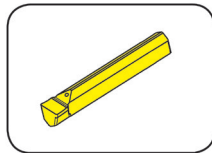

Page
T49-T50

Indexable insert
S25A

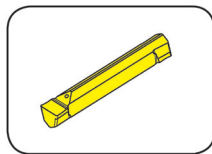

Page
T52-T53

T

15A/25A



T

Toolholder with Inserts

Width of groove .079 - .157"

Toolholder

H25A

from outer groove \varnothing
Depth of groove up to
Width of groove

15 mm
15 mm
2 - 3 mm

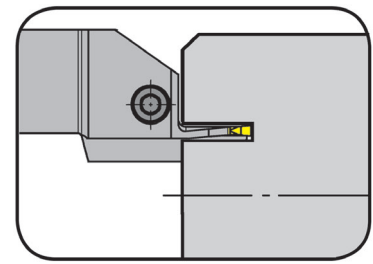

for Indexable insert

Type S15A
S25A

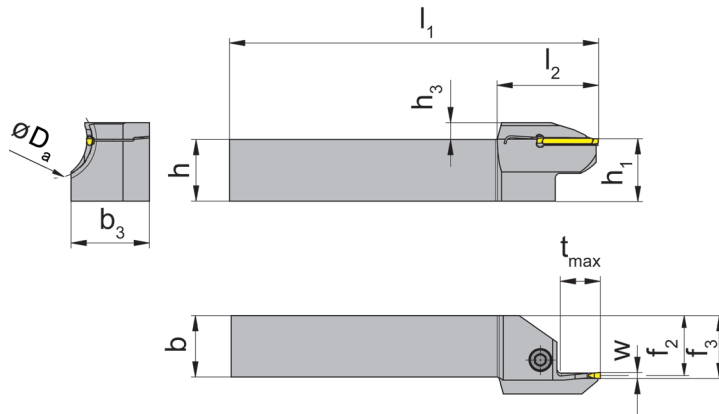

The cutting edge is above
0.3 mm the center height

L = left hand version shown

R = right hand version

Part number	h	b	l_1	l_2	h_1	b_3	f_2	f_3	t_{max}	h_3	$D_{a\ min}$	$D_{a\ max}$	Size
R/LAH25A.12.1520.02	12	12	120	32	12.3	15.5	11.5	12.5	12	5.0	15	20	02
R/LAH25A.16.1520.02	16	16	120	32	16.3	19.5	15.5	16.5	12	5.0	15	20	02
R/LAH25A.20.1520.02	20	20	120	32	20.3	23.5	19.5	20.5	12	5.0	15	20	02
R/LAH25A.12.2025.02	12	12	120	32	12.3	16.5	11.5	12.5	12	5.0	20	25	02
R/LAH25A.16.2025.02	16	16	120	32	16.3	20.5	15.5	16.5	12	5.0	20	25	02
R/LAH25A.20.2025.02	20	20	120	32	20.3	24.5	19.5	20.5	12	5.0	20	25	02
R/LAH25A.12.2530.02	12	12	120	33	12.3	17.5	11.5	12.5	13	5.5	25	30	02
R/LAH25A.16.2530.02	16	16	120	33	16.3	21.5	15.5	16.5	13	5.5	25	30	02
R/LAH25A.20.2530.02	20	20	120	33	20.3	25.5	19.5	20.5	13	5.5	25	30	02
R/LAH25A.12.1520.03	12	12	120	33	12.3	17.0	11.0	12.5	13	5.5	15	20	03
R/LAH25A.16.1520.03	16	16	120	33	16.3	21.0	15.0	16.5	13	5.5	15	20	03
R/LAH25A.20.1520.03	20	20	120	33	20.3	25.0	19.0	20.5	13	5.5	15	20	03
R/LAH25A.12.2025.03	12	12	120	34	12.3	18.5	11.0	12.5	14	5.5	20	25	03
R/LAH25A.16.2025.03	16	16	120	34	16.3	22.5	15.0	16.5	14	5.5	20	25	03
R/LAH25A.20.2025.03	20	20	120	34	20.3	26.5	19.0	20.5	14	5.5	20	25	03
R/LAH25A.12.2530.03	12	12	120	35	12.3	19.5	11.0	12.5	15	6.0	25	30	03
R/LAH25A.16.2530.03	16	16	120	35	16.3	23.5	15.0	16.5	15	6.0	25	30	03
R/LAH25A.20.2530.03	20	20	120	35	20.3	27.5	19.0	20.5	15	6.0	25	30	03

Further sizes upon request

w see indexable inserts

Dimensions in mm

Torque specification of the screw for $w = 2.0\text{ mm}$ is 2.5 Nm

Torque specification of the screw for $w = 3.0\text{ mm}$ is 3.0 Nm

State R or L version

Spare Parts

Toolholder	Clamping Screw	TORX PLUS® Wrench
R/LAH25A.12...	5.14T20P	T20PQ
R/LAH25A...	5.13 T20P	T20PQ

Cassette

K25A

from outer groove \varnothing
Depth of groove up to
Width of groove

15 mm
20 mm
2 - 4 mm

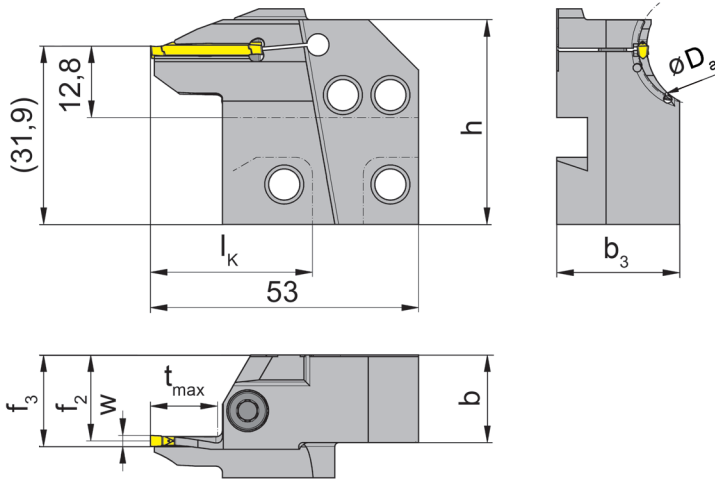
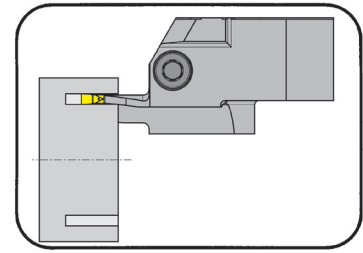

for Indexable insert

Type S15A
S25A

The cutting edge is above
0.3 mm the center height

R = right hand version shown

L = left hand version

Part number	$D_{a \min}$	$D_{a \max}$	t_{\max}	b	b_3	f_2	f_3	h	l_k	Size
R/LAK25A.1520.02.IK	15	20	12	15.7	21	15.4	$f_2+w/2$	38.6	34	02
R/LAK25A.2025.02.IK	20	25	12	15.7	22	15.4	$f_2+w/2$	38.6	34	02
R/LAK25A.2530.02.IK	25	30	13	15.7	23	15.4	$f_2+w/2$	38.6	34	02
R/LAK25A.2025.03.IK	20	25	14	15.7	24	14.9	$f_2+w/2$	38.6	34	03
R/LAK25A.2530.03.IK	25	30	15	15.7	25	14.9	$f_2+w/2$	38.6	34	03
R/LAK25A.3040.03.IK	30	40	16	15.7	23	14.9	$f_2+w/2$	38.6	34	03
R/LAK25A.4050.03.IK	40	50	18	15.7	24	14.9	$f_2+w/2$	38.6	34	03
R/LAK25A.2025.04.IK	20	25	16	15.7	24	15.1	$f_2+w/2$	38.6	34	04
R/LAK25A.2530.04.IK	25	30	17	15.7	24	15.1	$f_2+w/2$	38.6	34	04
R/LAK25A.3040.04.IK	30	40	18	15.7	24	15.1	$f_2+w/2$	38.6	34	04
R/LAK25A.4050.04.IK	40	50	20	15.7	24	15.1	$f_2+w/2$	39.2	34	04

Further sizes upon request

w see indexable inserts

Dimensions in mm

Torque specification of the screw for $w = 2.0$ mm is 2.5 Nm

Torque specification of the screw for $w = 3.0$ mm is 3.0 Nm

Torque specification of the screw for $w = 4.0$ mm is 3.5 Nm

Note:

for use with pocket seat system 220!

State R or L version

Spare Parts

Cassette	Clamping Screw	TORX PLUS® Wrench
R/LAK25A...	5.13 T20P	T20PQ

Toolholder

IB25A

from outer groove \varnothing
Depth of groove up to
Width of groove

20 mm
20 mm
2 - 4 mm

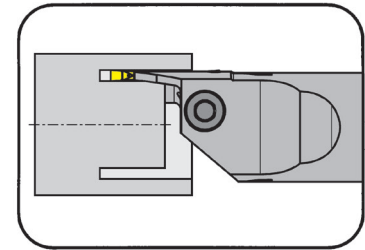

for Indexable insert

Type S15A
S25A

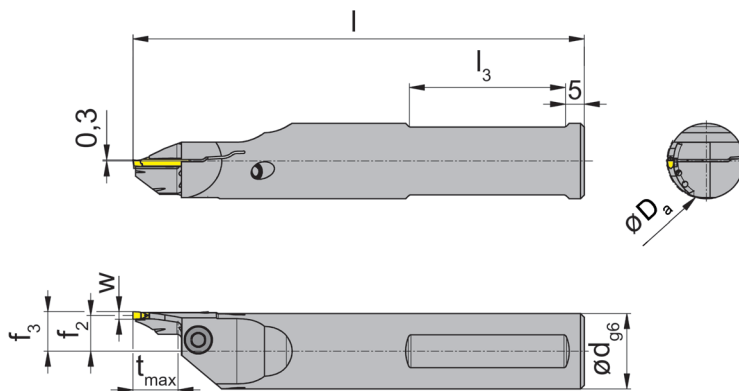

L = left hand version shown

R = right hand version

The cutting edge is above
0.3 mm the center height

Part number	d	l	l ₃	f ₃	f ₂	t _{max}	D _{a min}	D _{a max}	Width of groove
R/LIB25A.20.2025.02.IK	20	120	55	f ₂ +w/2	9.5	12	20	25	2
R/LIB25A.20.2530.02.IK	20	120	55	f ₂ +w/2	9.5	13	25	30	2
R/LIB25A.20.2025.03.IK	20	120	55	f ₂ +w/2	9.0	14	20	25	3
R/LIB25A.20.2530.03.IK	20	120	55	f ₂ +w/2	9.0	15	25	30	3
R/LIB25A.20.3040.03.IK	20	120	55	f ₂ +w/2	9.0	16	30	40	3
R/LIB25A.20.4050.03.IK	20	120	55	f ₂ +w/2	9.0	18	40	50	3
R/LIB25A.20.2025.04.IK	20	120	55	f ₂ +w/2	8.5	16	20	25	4
R/LIB25A.20.2530.04.IK	20	120	55	f ₂ +w/2	8.5	17	25	30	4
R/LIB25A.20.3040.04.IK	20	120	55	f ₂ +w/2	8.5	18	30	40	4
R/LIB25A.20.4050.04.IK	20	120	55	f ₂ +w/2	8.5	20	40	50	4
R/LIB25A.20.5065.04.IK	20	120	55	f ₂ +w/2	8.5	20	50	65	4
R/LIB25A.20.6580.04.IK	20	120	55	f ₂ +w/2	8.5	20	65	80	4

Further sizes upon request

w see indexable inserts

Dimensions in mm

Torque specification of the screw for w = 2.0 mm is 2.5 Nm
Torque specification of the screw for w = 3.0 mm is 3.0 Nm
Torque specification of the screw for w = 4.0 mm is 3.5 Nm

State R or L version

Spare Parts

Toolholder	Clamping Screw	TORX PLUS® Wrench
R/LIB25A...	5.13T20EP	T20PQ

Insert

S15A

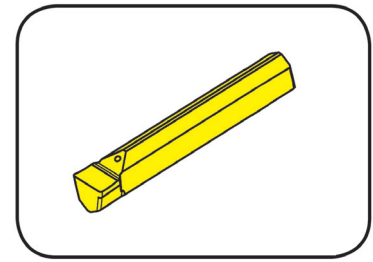

Width of groove .079 - .157"

Toolholder

Type H25A
IB25A
K25A

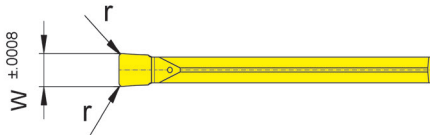
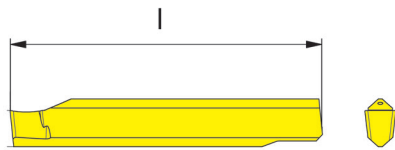

Indexability length ± .001"



Part number	w	r	l	Size	TH35	Carbide grades
S15A.0200.12	.079	.008	.787	02	▲	P •
S15A.0300.12	.118	.008	.827	03	▲	M •
S15A.0400.12	.157	.008	.945	04	▲	K •
						N •
						S •
						H -

▲ on stock Δ 4 weeks x upon request

- recommended
- alternative recommendation
- not suitable

- uncoated grades
- coated grades
- brazed/Cermet

Dimensions in inch

Carbide grades

Indexable inserts can be used in **right and left** hand toolholders.

Insert

S15A

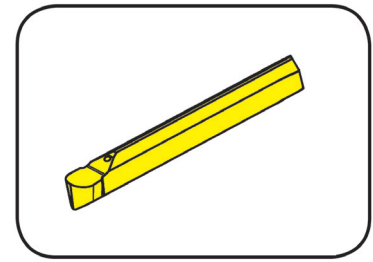

Full radius	.039 - .079"
Width of groove	.079 - .157"

for Toolholder

Type H25A
IB25A
K25A

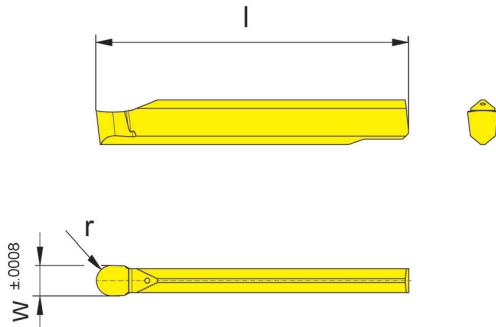

Indexability length ± .001"

Part number	w	l	r	Size	TH35	Carbide grades
S15A.0200.10.10	.079	.787	.039	02	▲	P •
S15A.0300.10.15	.118	.827	.059	03	▲	M •
S15A.0400.10.20	.157	.945	.079	04	▲	K •
						N •
						S •
						H -

▲ on stock Δ 4 weeks x upon request

- recommended
- alternative recommendation
- not suitable

- uncoated grades
- coated grades
- brazed/Cermet

Dimensions in inch

Carbide grades

Indexable inserts can be used in **right and left** hand toolholders.

Insert

S15A

Width of groove .157"

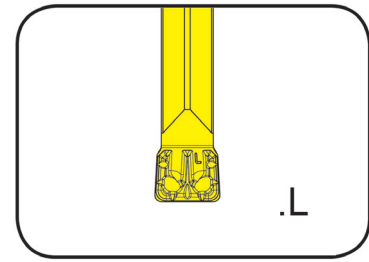

for Toolholder

Type H25A
IB25A
K25A

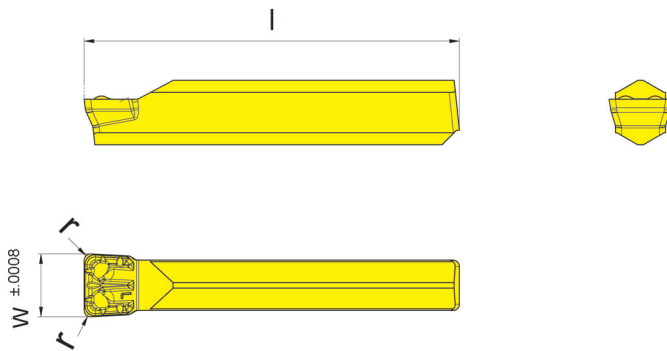

Indexability length ± .001"

Part number	w	r	l	Size	AS45
S15A.0400.L4	.157	.016	.945	04	▲
					P ●
					M ●
					K ●
					N ○
					S ●
					H -

▲ on stock Δ 4 weeks x upon request
● recommended
○ alternative recommendation
- not suitable
□ uncoated grades
■ coated grades
■ brazed/Cermet
Dimensions in inch

Carbide grades

Indexable inserts can be used in **right and left** hand toolholders.



Indexable insert

S25A

Width of groove .079 - .157"

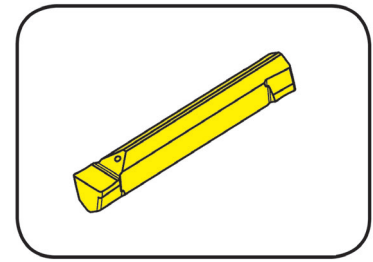

for Toolholder

Type H25A
IB25A
K25A

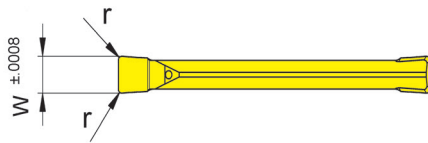
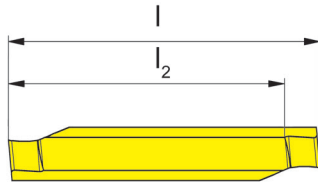

Indexability length $\pm .001''$

Part number	w	r	l	l ₂	Size	TH35	Carbide grades
S25A.0200.12	.079	.008	.787	.669	02	▲	P •
S25A.0300.12	.118	.008	.827	.709	03	▲	M •
S25A.0400.12	.157	.008	.945	.807	04	▲	K •
							N •
							S •
							H -

▲ on stock Δ 4 weeks x upon request

- recommended
- alternative recommendation
- not suitable

- uncoated grades
- coated grades
- brazed/Cermet

Dimensions in inch

Carbide grades

Indexable inserts can be used in right and left hand toolholders.



Indexable insert

S25A

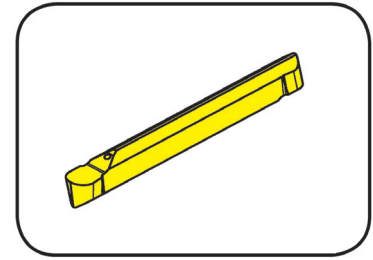

Full radius	.039 - .079"
Width of groove	.079 - .157"

for Toolholder

Type H25A
IB25A
K25A

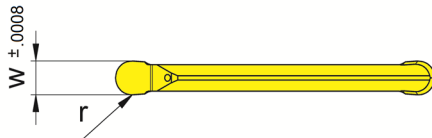
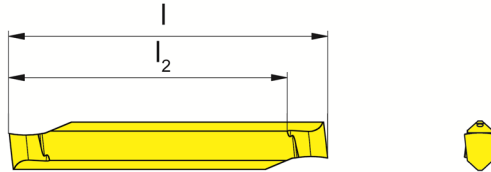

Indexability length ± .001"



Part number	w	l	r	l ₂	Size	TH35	Carbide grades
S25A.0200.10.10	.079	.787	.039	.669	02	▲	P •
S25A.0300.10.15	.118	.827	.059	.709	03	▲	M •
S25A.0400.10.20	.157	.945	.079	.807	04	▲	K •
							N •
							S •
							H -

▲ on stock Δ 4 weeks x upon request

- recommended
- alternative recommendation
- not suitable

- uncoated grades
- coated grades
- brazed/Cermet

Dimensions in inch

Carbide grades

Indexable inserts can be used in right and left hand toolholders.

Toolholder
U220/220
BU224/B224

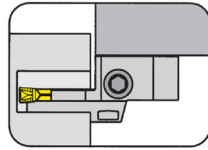

Page
T56-T61

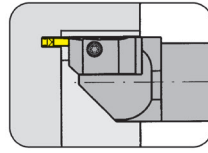

Page
T62-T63

Cassette
R/LIK220
R/LAK220

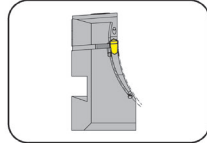

Page
T64-T67

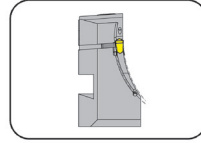

Page
T68-T71

Insert
S224/S124

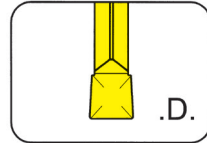

Page
T72

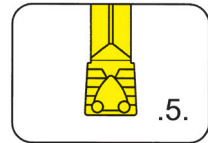

Page
T73

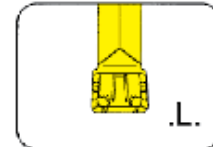

Page
T74

T

224



T

Toolholder with Inserts

Width of groove .118 - .236"

Basic toolholder

U220

without cassette

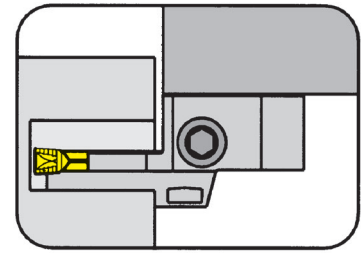

Basic toolholder for cassettes type 220/224

Shank parallel to the axis of workpiece

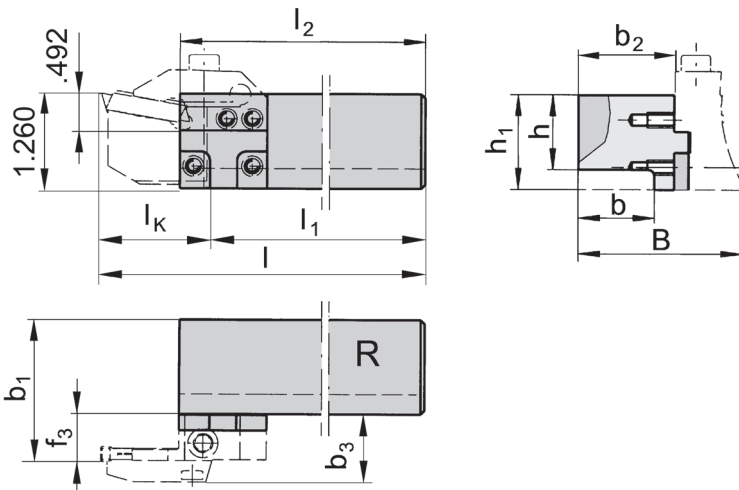

R = right hand version shown

L = left hand version

with integrated through coolant supply

Part number	h	h ₁	l ₁	b	b ₁	b ₂	l ₂	l	B
R/LU220.0625.K1.IK	.625	1.250	l ₂ -.394	.625	b ₂ +f ₃	1.000	2.520	l ₁ +l _K	b ₂ +b ₃
R/LU220.0750.2.K1.IK	.750	1.250	l ₂ -.394	.750	b ₂ +f ₃	1.000	2.992	l ₁ +l _K	b ₂ +b ₃
R/LU220.1000.2.K1.IK	1.000	1.250	l ₂ -.394	1.000	b ₂ +f ₃	1.250		l ₁ +l _K	b ₂ +b ₃
R/LU220.1250.2.K1.IK	1.250	1.250	l ₂ -.394	1.250	b ₂ +f ₃	1.250	4.331	l ₁ +l _K	b ₂ +b ₃

State R or L version

l_K, b₃ and f₃ see cassettes

Dimensions in inch

Further sizes upon request

Use right hand basic toolholder for right hand cassettes and left hand basic toolholder for left hand cassettes.

Spare Parts

Basic toolholder	Clamping Screw	TORX PLUS® Wrench
R/LU220...	5.12T20P	T20PQ

Basic toolholder

220

without cassette

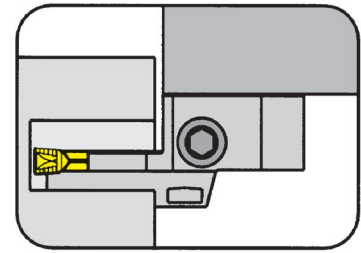

Basic toolholder for cassettes type 220/224

Shank parallel to the axis of workpiece

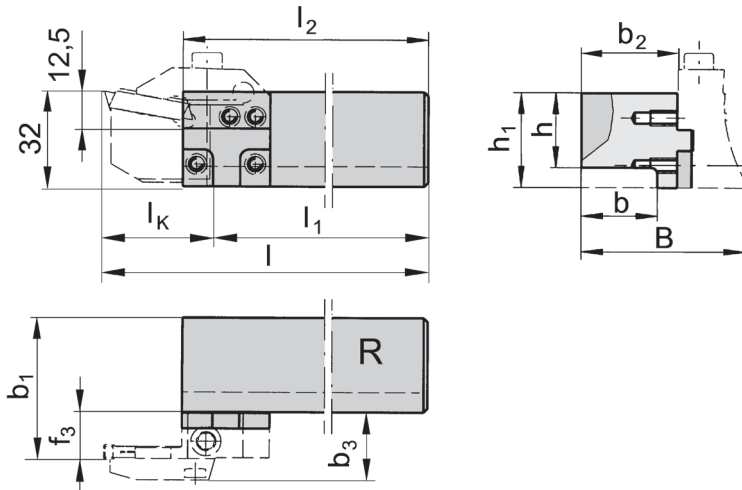

R = right hand version shown

L = left hand version

Part number	h	h ₁	l ₁	b	b ₁	b ₂	l ₂	l	B
R/L220.1616.K1	16	32	l ₂ -10	16	b ₂ +f ₃	25	64	l ₁ +l _K	b ₂ +b ₃
R/L220.2020.K1	20	32	l ₂ -10	20	b ₂ +f ₃	27	74	l ₁ +l _K	b ₂ +b ₃
R/L220.2525.K1	25	32	l ₂ -10	25	b ₂ +f ₃	32	94	l ₁ +l _K	b ₂ +b ₃
R/L220.3225.K1	32	32	l ₂ -10	-	b ₂ +f ₃	25	109	l ₁ +l _K	b ₂ +b ₃
R/L220.3232.K1	32	32	l ₂ -10	-	b ₂ +f ₃	32	109	l ₁ +l _K	b ₂ +b ₃

State R or L version

l_K, b₃ and f₃ see cassettes

Dimensions in mm

Further sizes upon request

Use right hand basic toolholder for right hand cassettes and left hand basic toolholder for left hand cassettes.

Spare Parts

Basic toolholder	Clamping Screw	Allen wrench	TORX PLUS® Wrench	Threaded Pin
L220.1616.K1	5.12T20P	SW5,0 DIN911	T20PQ	
R/L220...	5.12T20P		T20PQ	
R220.2020.K1	5.12T20P		T20PQ	030.0508.0866

Basic toolholder

220

without cassette

suitable for HORN adaptors VDI with integrated through coolant supply

Shank parallel to the axis of workpiece

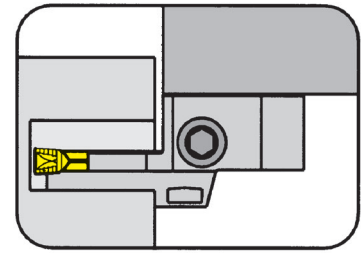

for Cassette

Type 220
224

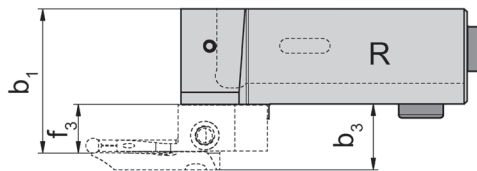
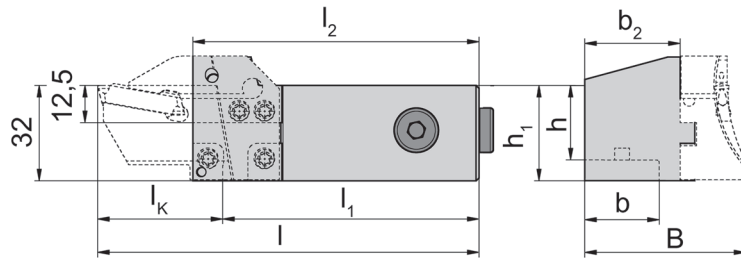

R = right hand version shown

L = left hand version

with integrated through coolant supply

Part number	h	h ₁	l ₁	b	b ₁	b ₂	l ₂	l	B
R/L220.2020.2.K1.IK	20	32	l ₂ -10	20	b ₂ +f ₃	27	84	l ₁ +l _k	b ₂ +b ₃
R/L220.2525.2.K1.IK	25	32	l ₂ -10	25	b ₂ +f ₃	32	96	l ₁ +l _k	b ₂ +b ₃

State R or L version

l_k, b₃ and f₃ see cassettes

Dimensions in mm

Further sizes upon request

Use right hand basic toolholder for right hand cassettes and left hand basic toolholder for left hand cassettes.

Spare Parts

Basic toolholder	Clamping Screw	Sealing plug	Threaded Pin	O-ring	TORX PLUS® Wrench
R/L220...	5.12T20P	004.00.26	030.0508.0866	12.37.2.62.3601	T20PQ

Face Grooving



Basic toolholder

U220

without cassette

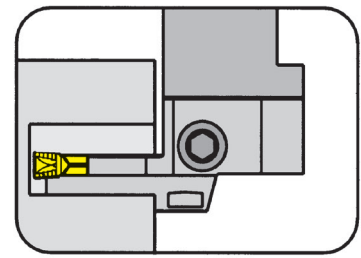

Basic toolholder for cassettes type 220/224

Shank 90° to the axis of workpiece

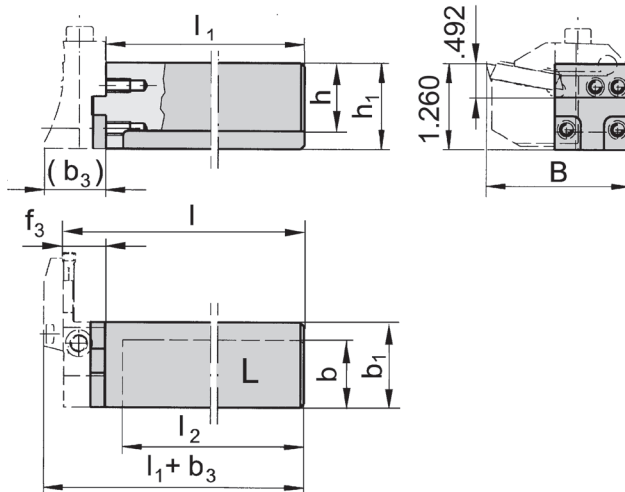

L = left hand version shown

R = right hand version

Part number	h	h ₁	b	l ₂	l	B	b ₁	l ₁
R/LU220.0625.K2.IK	.625	1.250	.625	2.953	l ₁ +f ₃	IK+.748	1.000	2.756
R/LU220.0750.2.K2.IK	.750	1.250	.750	3.701	l ₁ +f ₃	IK+.748	1.000	3.504
R/LU220.1000.2.K2.IK	1.000	1.250	1.000	3.625	l ₁ +f ₃	IK+.866	1.250	4.000
R/LU220.1250.2.K2.IK	1.250	1.250			l ₁ +f ₃	IK+.866	1.250	4.500

State R or L version

l_k, b₃ and f₃ see cassettes

Dimensions in inch

Further sizes upon request

Use right hand basic toolholder for left hand cassettes and left hand basic toolholder for right hand cassettes.

Spare Parts

Basic toolholder	Clamping Screw	TORX PLUS® Wrench
R/LU220...	5.12T20P	T20PQ



Basic toolholder

220

without cassette

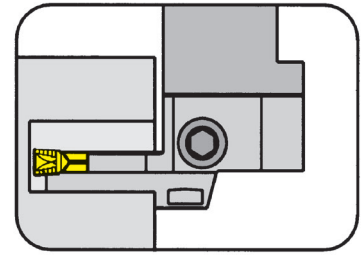

Basic toolholder for cassettes type 220/224

Shank 90° to the axis of workpiece

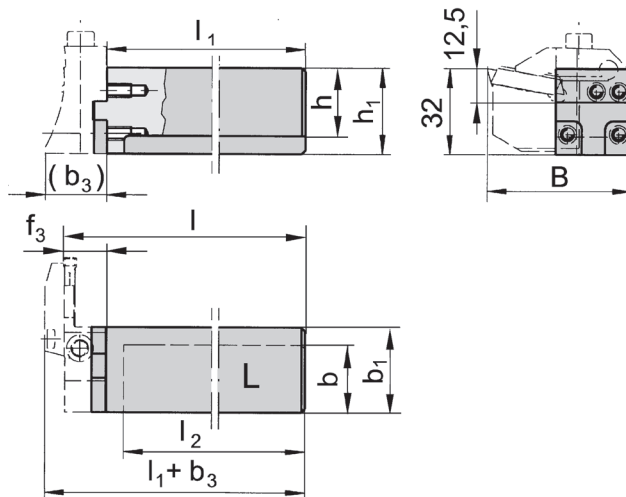

L = left hand version shown

R = right hand version

Part number	h	h ₁	b	l ₂	l	B	b ₁	l ₁
R/L220.1616.K2	16	32	16	60	l ₁ +f ₃	l _k +19	29	70
R/L220.2020.K2	20	32	20	75	l ₁ +f ₃	l _k +19	29	85
R/L220.2525.K2	25	32	25	93	l ₁ +f ₃	l _k +22	32	100
R/L220.3225.K2	32	32	-	108	l ₁ +f ₃	l _k +19	29	115
R/L220.3232.K2	32	32	-	115	l ₁ +f ₃	l _k +22	32	115

State R or L version

l_k, b₃ and f₃ see cassettes

Dimensions in mm

Further sizes upon request

Use right hand basic toolholder for left hand cassettes and left hand basic toolholder for right hand cassettes.

Spare Parts

Basic toolholder	Clamping Screw	TORX PLUS® Wrench
R/L220...	5.12T20P	T20PQ

Basic toolholder

220

without cassette

suitable for HORN adaptors VDI with integrated through coolant supply

Shank 90° to the axis of workpiece

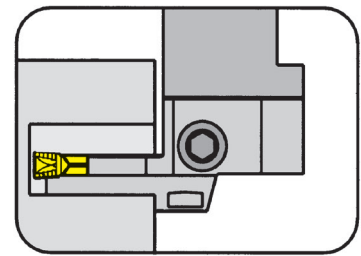

for Cassette

Type 220
224

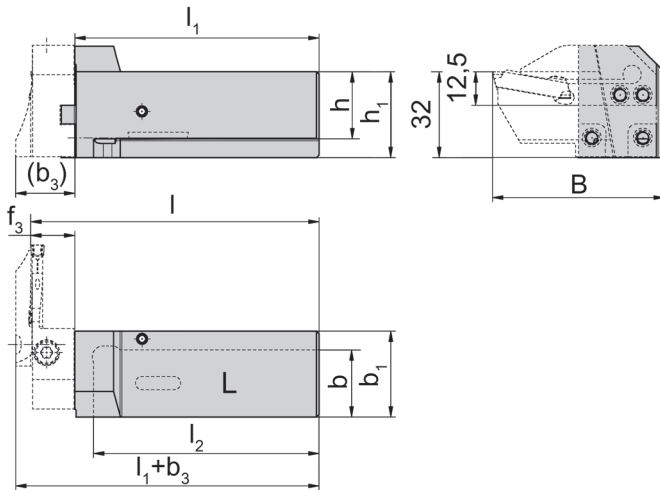

L = left hand version shown

R = right hand version

with integrated through coolant supply

Part number	h	h ₁	b	l ₂	l	B	b ₁	l ₁
R/L220.2020.2.K2.IK	20	32	20	69	l ₁ +f ₃	l _k +19	29	79
R/L220.2525.2.K2.IK	25	32	25	84	l ₁ +f ₃	l _k +19	32	91

State R or L version

l_k, b₃ and f₃ see cassettes

Dimensions in mm

Further sizes upon request

Use right hand basic toolholder for left hand cassettes and left hand basic toolholder for right hand cassettes.

Spare Parts

Basic toolholder	Clamping Screw	Sealing plug	Threaded Pin	O-ring	TORX PLUS® Wrench
R/L220...	5.12T20P	004.00.26	030.0508.0866	12.37.2.62.3601	T20PQ

Face Grooving



Basic toolholder

BU224

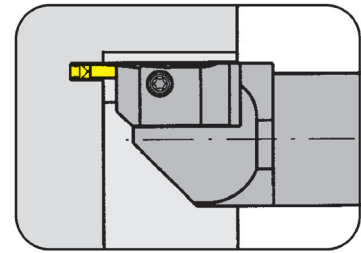

Basic toolholder for cassettes type 220/224

with through coolant supply

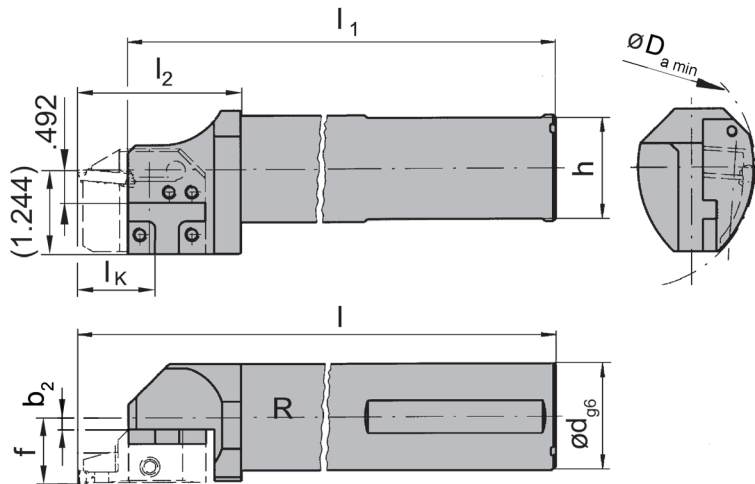

R = right hand version shown

L = left hand version

with integrated through coolant supply

Part number	f	d	l ₁	h	l ₂	b ₂	l	D _{Bohr}
R/LBU224.1250.K1.IK	.780	1.250	7.126	1.171	2.323	.016	7.874	3.543
R/LBU224.1500.K1.IK	.937	1.500	9.094	1.421	2.323	.173	9.843	3.543

State R or L version

D_{amin} / f₃ / l_K see cassettes

Dimensions in inch

Further sizes upon request

Basic toolholder	Screw	TORX PLUS® Wrench
R/LBU224.1...	5.12T20P	T20PQ

Basic toolholder

B224

without cassette

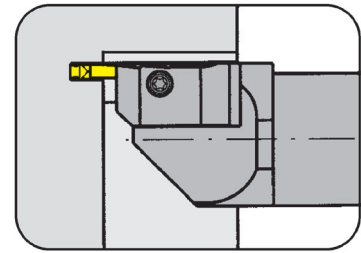

Basic toolholder for cassettes type RIK/LIK224

with through coolant supply

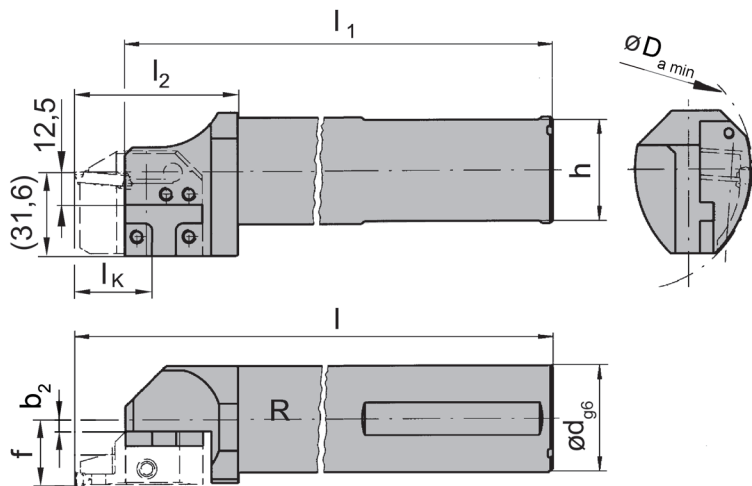

R = right hand version shown

L = left hand version

Part number	f	d	l ₁	h	l ₂	b ₂	l	D _{Bohr}
R/LB224.0032.K1	b ₂ +f ₃	32	181	30	59	.41	200	90
R/LB224.0040.K1	b ₂ +f ₃	40	231	38	59	4.41	250	90
R/LB224.0040.K1.IK	b ₂ +f ₃	40	231	38	59	4.41	250	90
R/LB224.0032.K1.IK	b ₂ +f ₃	32	181	30	59	.41	200	90

State R or L version

D_{a min} / f₃ / l_K see cassettes

Dimensions in mm

Further sizes upon request

Spare Parts

Basic toolholder	Clamping Screw	TORX PLUS® Wrench
R/LB224.0...	5.12T20P	T20PQ

Cassette

LAK224

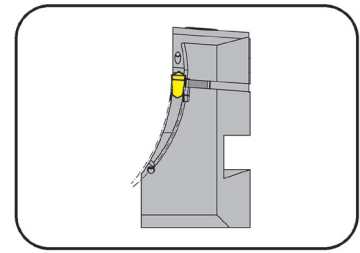

Outer groove Ø
Depth of groove up to
Width of groove

38 - 1000 mm
14 mm
3 - 4 mm

for Indexable insert

Type S224

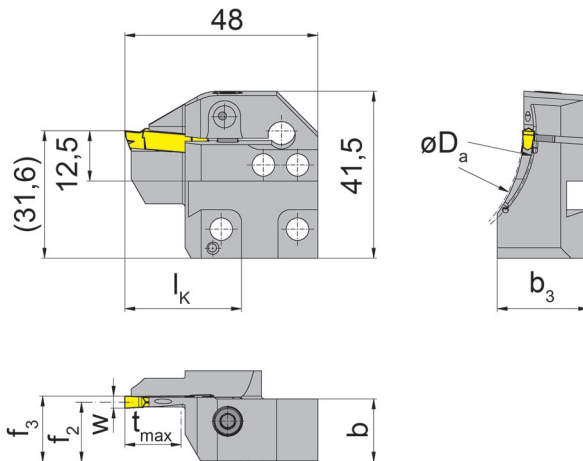

L = left hand version

Part number	D _{a min}	D _{a max}	t _{max}	b	b ₃	f ₂	f ₃	w	l _k
LAK224.5060.03.IK	50	60	14	15.7	23.7	14.9	f ₂ +w/2	3	29
LAK224.6075.03.IK	60	75	14	15.7	22.7	14.9	f ₂ +w/2	3	29
LAK224.7590.03.IK	75	90	14	15.7	22.7	14.9	f ₂ +w/2	3	29
LAK224.9011.03.IK	90	110	14	15.7	21.0	14.9	f ₂ +w/2	3	29
LAK224.1113.03.IK	110	130	14	15.7	21.0	14.9	f ₂ +w/2	3	29
LAK224.1318.03.IK	130	180	14	15.7	20.0	14.9	f ₂ +w/2	3	29
LAK224.1830.03.IK	180	300	14	15.7	19.0	14.9	f ₂ +w/2	3	29
LAK224.3000.03.IK	300	1000	14	15.7	16.9	14.9	f ₂ +w/2	3	29
LAK224.3847.04.IK	38	47	14	15.7	24.2	14.4	f ₂ +w/2	4	29
LAK224.4760.04.IK	47	60	14	15.7	23.7	14.4	f ₂ +w/2	4	29
LAK224.6075.04.IK	60	75	14	15.7	23.7	14.4	f ₂ +w/2	4	29
LAK224.7590.04.IK	75	90	14	15.7	22.7	14.4	f ₂ +w/2	4	29
LAK224.9013.04.IK	90	130	14	15.7	21.0	14.4	f ₂ +w/2	4	29
LAK224.1318.04.IK	130	180	14	15.7	21.0	14.4	f ₂ +w/2	4	29
LAK224.1830.04.IK	180	300	14	15.7	19.0	14.4	f ₂ +w/2	4	29
LAK224.3000.04.IK	300	1000	14	15.7	16.7	14.4	f ₂ +w/2	4	29

For basic toolholder L...K1/L...K1.IK and R...K2/R...K2.IK

Dimensions in mm

Further sizes upon request

Ordering note:

The fastening screw is combined with the basic toolholder - no separate order required.

For torque specification of the screw, please see Technical Instructions.

Spare Parts

Cassette	Clamping Screw	TORX PLUS® Wrench
LAK224...	5.13 T20P	T20PQ

Cassette

LAK224

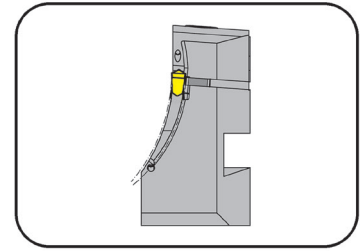

Outer groove Ø
Depth of groove up to
Width of groove

38 - 1000 mm
14 mm
5 - 6 mm

for Indexable insert

Type S224

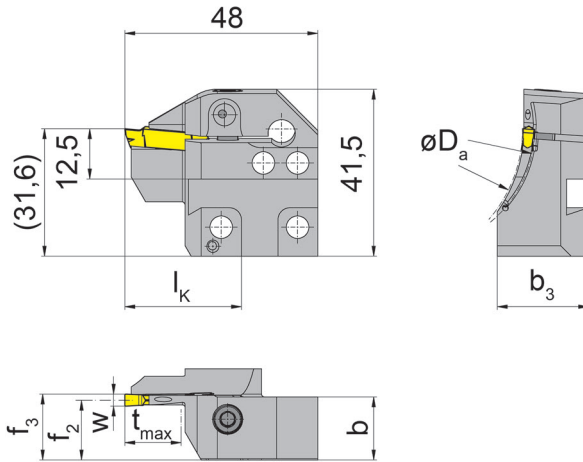

L = left hand version

Part number	D _{a min}	D _{a max}	t _{max}	b	b ₃	f ₂	f ₃	w	l _k
LAK224.3847.05.IK	38	47	14	15.7	23.7	13.9	f ₂ +w/2	5	29
LAK224.4760.05.IK	47	60	14	15.7	23.7	13.9	f ₂ +w/2	5	29
LAK224.6075.05.IK	60	75	14	15.7	23.7	13.9	f ₂ +w/2	5	29
LAK224.7590.05.IK	75	90	14	15.7	22.0	13.9	f ₂ +w/2	5	29
LAK224.9013.05.IK	90	130	14	15.7	22.0	13.9	f ₂ +w/2	5	29
LAK224.1318.05.IK	130	180	14	15.7	21.0	13.9	f ₂ +w/2	5	29
LAK224.1830.05.IK	180	300	14	15.7	19.0	13.9	f ₂ +w/2	5	29
LAK224.3000.05.IK	300	1000	14	15.7	16.7	13.9	f ₂ +w/2	5	29
LAK224.6075.06.IK	60	75	14	15.7	23.0	13.4	f ₂ +w/2	6	29
LAK224.7590.06.IK	75	90	14	15.7	23.0	13.4	f ₂ +w/2	6	29
LAK224.9013.06.IK	90	130	14	15.7	21.0	13.4	f ₂ +w/2	6	29
LAK224.1318.06.IK	130	180	14	15.7	21.0	13.4	f ₂ +w/2	6	29
LAK224.1830.06.IK	180	300	14	15.7	19.0	13.4	f ₂ +w/2	6	29
LAK224.3000.06.IK	300	1000	14	15.7	16.7	13.4	f ₂ +w/2	6	29

For basic toolholder L...K1/L...K1.IK and R...K2/R...K2.IK

Dimensions in mm

Further sizes upon request

Ordering note:

The fastening screw is combined with the basic toolholder - no separate order required.

For torque specification of the screw, please see Technical Instructions.

Spare Parts

Cassette	Clamping Screw	TORX PLUS® Wrench
LAK224...	5.13 T20P	T20PQ



Cassette

RAK224

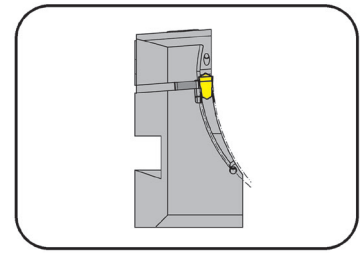

Outer groove Ø
Depth of groove up to
Width of groove

38 - 1000 mm
14 mm
3 - 4 mm

for Indexable insert

Type S224

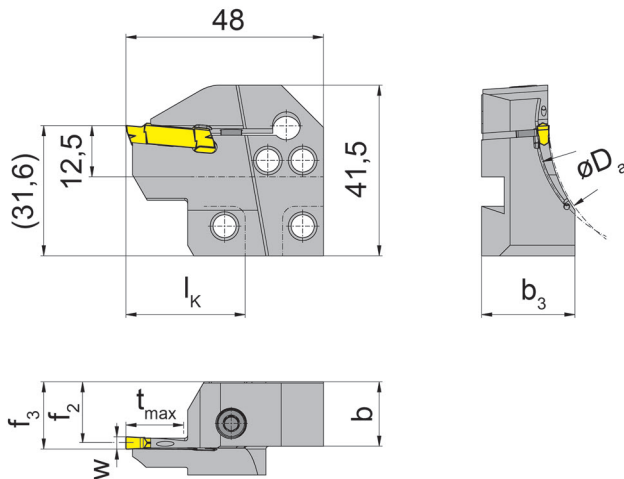

R = right hand version

Part number	D _{a min}	D _{a max}	t _{max}	b	b ₃	f ₂	f ₃	w	l _k
RAK224.5060.03.IK	50	60	14	15.7	23.7	14.9	f ₂ +w/2	3	29
RAK224.6075.03.IK	60	75	14	15.7	22.7	14.9	f ₂ +w/2	3	29
RAK224.7590.03.IK	75	90	14	15.7	22.7	14.9	f ₂ +w/2	3	29
RAK224.9011.03.IK	90	110	14	15.7	21.0	14.9	f ₂ +w/2	3	29
RAK224.1113.03.IK	110	130	14	15.7	21.0	14.9	f ₂ +w/2	3	29
RAK224.1318.03.IK	130	180	14	15.7	20.0	14.9	f ₂ +w/2	3	29
RAK224.1830.03.IK	180	300	14	15.7	19.0	14.9	f ₂ +w/2	3	29
RAK224.3000.03.IK	300	1000	14	15.7	16.9	14.9	f ₂ +w/2	3	29
RAK224.3847.04.IK	38	47	14	15.7	24.2	14.4	f ₂ +w/2	4	29
RAK224.4760.04.IK	47	60	14	15.7	23.7	14.4	f ₂ +w/2	4	29
RAK224.6075.04.IK	60	75	14	15.7	23.7	14.4	f ₂ +w/2	4	29
RAK224.7590.04.IK	75	90	14	15.7	22.7	14.4	f ₂ +w/2	4	29
RAK224.9013.04.IK	90	130	14	15.7	21.0	14.4	f ₂ +w/2	4	29
RAK224.1318.04.IK	130	180	14	15.7	21.0	14.4	f ₂ +w/2	4	29
RAK224.1830.04.IK	180	300	14	15.7	19.0	14.4	f ₂ +w/2	4	29
RAK224.3000.04.IK	300	1000	14	15.7	16.7	14.4	f ₂ +w/2	4	29

For basic toolholder R...K1/R...K1IK and L...K2/L...K2.IK

Dimensions in mm

Further sizes upon request

Ordering note:

The fastening screw is combined with the basic toolholder - no separate order required.

For torque specification of the screw, please see Technical Instructions.

Spare Parts

Cassette	Clamping Screw	TORX PLUS® Wrench
RAK224...	5.13 T20P	T20PQ

Cassette

RAK224

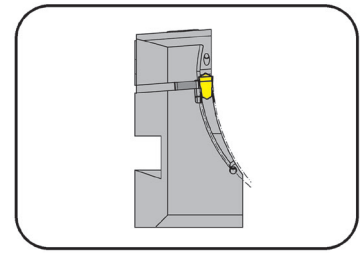

Outer groove \varnothing
Depth of groove up to
Width of groove

38 - 1000 mm
14 mm
5 - 6 mm

for Indexable insert

Type S224

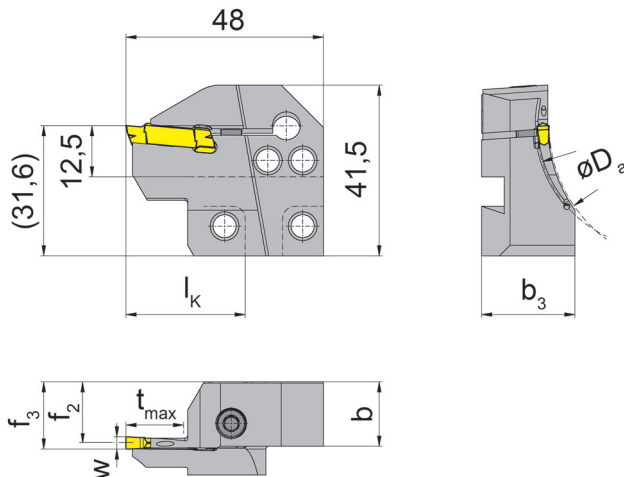

R = right hand version

Part number	$D_{a \min}$	$D_{a \max}$	t_{\max}	b	b_3	f_2	f_3	w	l_k
RAK224.3847.05.IK	38	47	14	15.7	23.7	13.9	$f_2 + w/2$	5	29
RAK224.4760.05.IK	47	60	14	15.7	23.7	13.9	$f_2 + w/2$	5	29
RAK224.6075.05.IK	60	75	14	15.7	23.7	13.9	$f_2 + w/2$	5	29
RAK224.7590.05.IK	75	90	14	15.7	22.0	13.9	$f_2 + w/2$	5	29
RAK224.9013.05.IK	90	130	14	15.7	22.0	13.9	$f_2 + w/2$	5	29
RAK224.1318.05.IK	130	180	14	15.7	21.0	13.9	$f_2 + w/2$	5	29
RAK224.1830.05.IK	180	300	14	15.7	19.0	13.9	$f_2 + w/2$	5	29
RAK224.3000.05.IK	300	1000	14	15.7	16.7	13.9	$f_2 + w/2$	5	29
RAK224.6075.06.IK	60	75	14	15.7	23.0	13.4	$f_2 + w/2$	6	29
RAK224.7590.06.IK	75	90	14	15.7	23.0	13.4	$f_2 + w/2$	6	29
RAK224.9013.06.IK	90	130	14	15.7	21.0	13.4	$f_2 + w/2$	6	29
RAK224.1318.06.IK	130	180	14	15.7	21.0	13.4	$f_2 + w/2$	6	29
RAK224.1830.06.IK	180	300	14	15.7	19.0	13.4	$f_2 + w/2$	6	29
RAK224.3000.06.IK	300	1000	14	15.7	16.7	13.4	$f_2 + w/2$	6	29

For basic toolholder R...K1/R...K1IK and L...K2/L...K2.IK

Dimensions in mm

Further sizes upon request

Ordering note:

The fastening screw is combined with the basic toolholder - no separate order required.

For torque specification of the screw, please see Technical Instructions.

Spare Parts

Cassette	Clamping Screw	TORX PLUS® Wrench
RAK224...	5.13 T20P	T20PQ



Cassette

LIK224

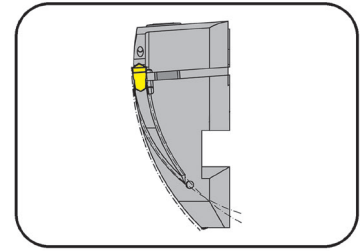

Outer groove \varnothing
Depth of groove up to
Width of groove

38 - 1000 mm
14 mm
3 - 4 mm

for Indexable insert

Type S224

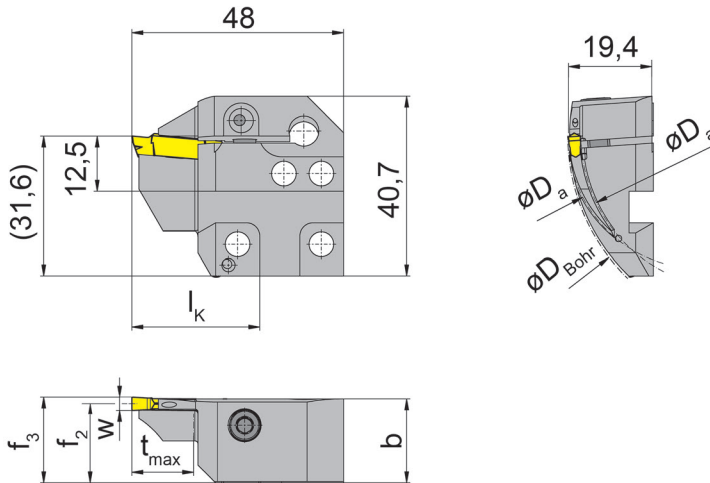

L = left hand version

Part number	D_{Bohr}	$D_{a \min}$	$D_{a \max}$	t_{\max}	b	f_2	f_3	w	l_k
LIK224.5060.03.IK	90	50	60	14	19	17.9	$f_2+w/2$	3	29
LIK224.6075.03.IK	90	60	75	14	19	17.9	$f_2+w/2$	3	29
LIK224.7590.03.IK	90	75	90	14	19	17.9	$f_2+w/2$	3	29
LIK224.9011.03.IK	90	90	110	14	19	17.9	$f_2+w/2$	3	29
LIK224.1113.03.IK	110	110	130	14	19	17.9	$f_2+w/2$	3	29
LIK224.1318.03.IK	130	130	180	14	19	17.9	$f_2+w/2$	3	29
LIK224.1830.03.IK	180	180	300	14	19	17.9	$f_2+w/2$	3	29
LIK224.3847.04.IK	90	38	47	14	19	17.4	$f_2+w/2$	4	29
LIK224.4760.04.IK	90	47	60	14	19	17.4	$f_2+w/2$	4	29
LIK224.6075.04.IK	90	60	75	14	19	17.4	$f_2+w/2$	4	29
LIK224.7590.04.IK	90	75	90	14	19	17.4	$f_2+w/2$	4	29
LIK224.9013.04.IK	90	90	130	14	19	17.4	$f_2+w/2$	4	29
LIK224.1318.04.IK	130	130	180	14	19	17.4	$f_2+w/2$	4	29
LIK224.3000.04.IK	300	300	1000	14	19	17.4	$f_2+w/2$	4	29

For basic toolholder L...K1/L...K1.IK and R...K2/R...K2.IK

Dimensions in mm

Further sizes upon request

Ordering note:

The fastening screw is combined with the basic toolholder - no separate order required.

For torque specification of the screw, please see Technical Instructions.

Spare Parts

Cassette	Clamping Screw	TORX PLUS® Wrench
LIK224...	5.13 T20P	T20PQ

Cassette

LIK224

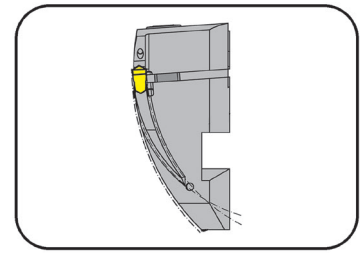

Outer groove \emptyset
Depth of groove up to
Width of groove

38 - 1000 mm
14 mm
5 - 6 mm

for Indexable insert

Type S224

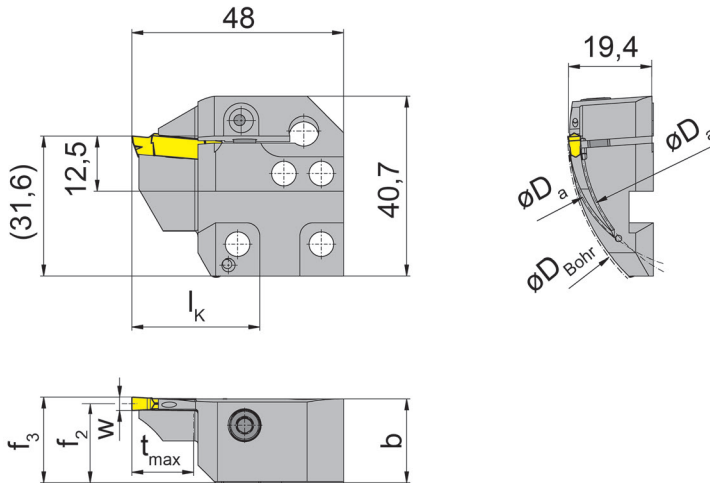

L = left hand version

Part number	D_{Bohr}	$D_{a \min}$	$D_{a \max}$	t_{max}	b	f_2	f_3	w	l_k
LIK224.3847.05.IK	90	38	47	14	19.00	16.9	$f_2+w/2$	5	29
LIK224.4760.05.IK	90	47	60	14	19.00	17.4	$f_2+w/2$	5	29
LIK224.6075.05.IK	90	60	75	14	19.00	16.9	$f_2+w/2$	5	29
LIK224.7590.05.IK	90	75	90	14	19.00	16.9	$f_2+w/2$	5	29
LIK224.9013.05.IK	90	90	130	14	19.00	16.9	$f_2+w/2$	5	29
LIK224.1318.05.IK	130	130	180	14	19.00	16.9	$f_2+w/2$	5	29
LIK224.1830.05.IK	180	180	300	14	19.00	16.9	$f_2+w/2$	5	29
LIK224.3000.05.IK	300	300	1000	14	18.90	16.9	$f_2+w/2$	5	29
LIK224.6075.06.IK	90	60	75	14	19.00	16.4	$f_2+w/2$	6	29
LIK224.7590.06.IK	90	75	90	14	19.00	16.4	$f_2+w/2$	6	29
LIK224.9013.06.IK	90	90	130	14	19.00	16.4	$f_2+w/2$	6	29
LIK224.1318.06.IK	130	130	180	14	19.00	16.4	$f_2+w/2$	6	29
LIK224.1830.06.IK	180	180	300	14	19.00	16.4	$f_2+w/2$	6	29
LIK224.3000.06.IK	300	300	1000	14	18.75	16.4	$f_2+w/2$	6	29

For basic toolholder L...K1/L...K1.IK and R...K2/R...K2.IK

Dimensions in mm

Further sizes upon request

Ordering note:

The fastening screw is combined with the basic toolholder - no separate order required.

For torque specification of the screw, please see Technical Instructions.

Spare Parts

Cassette	Clamping Screw	TORX PLUS® Wrench
LIK224...	5.13 T20P	T20PQ

Cassette

RIK224

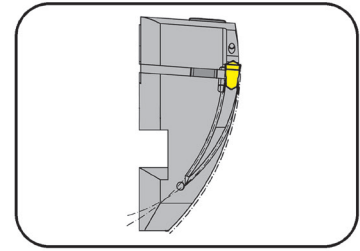

Outer groove \varnothing
Depth of groove up to
Width of groove

38 - 1000 mm
14 mm
3 - 4 mm

for Indexable insert

Type S224

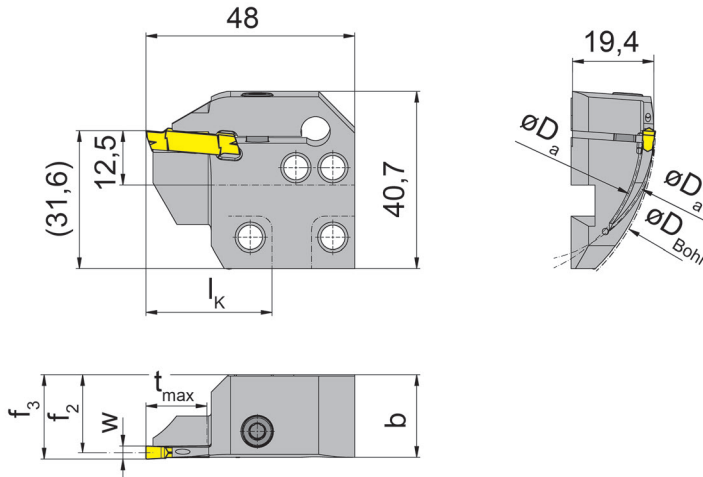

R = right hand version

Part number	D_{Bohr}	$D_{a \min}$	$D_{a \max}$	t_{\max}	b	f_2	f_3	w	l_K
RIK224.5060.03.IK	90	50	60	14	19.00	17.9	$f_2+w/2$	3	29
RIK224.6075.03.IK	90	60	75	14	19.00	17.9	$f_2+w/2$	3	29
RIK224.7590.03.IK	90	75	90	14	19.00	17.9	$f_2+w/2$	3	29
RIK224.9011.03.IK	90	90	110	14	19.00	17.9	$f_2+w/2$	3	29
RIK224.1113.03.IK	110	110	130	14	19.00	17.9	$f_2+w/2$	3	29
RIK224.1318.03.IK	130	130	180	14	19.05	17.9	$f_2+w/2$	3	29
RIK224.1830.03.IK	180	180	300	14	19.00	17.9	$f_2+w/2$	3	29
RIK224.3847.04.IK	90	38	47	14	19.00	17.4	$f_2+w/2$	4	29
RIK224.4760.04.IK	90	47	60	14	19.00	17.4	$f_2+w/2$	4	29
RIK224.6075.04.IK	90	60	75	14	19.00	17.4	$f_2+w/2$	4	29
RIK224.7590.04.IK	90	75	90	14	19.00	17.4	$f_2+w/2$	4	29
RIK224.9013.04.IK	90	90	130	14	19.00	17.4	$f_2+w/2$	4	29
RIK224.1318.04.IK	130	130	180	14	19.00	17.4	$f_2+w/2$	4	29
RIK224.3000.04.IK	300	300	1000	14	19.00	17.4	$f_2+w/2$	4	29

For basic toolholder R...K1/R...K1IK and L...K2/L...K2.IK

Dimensions in mm

Further sizes upon request

Ordering note:

The fastening screw is combined with the basic toolholder - no separate order required.

For torque specification of the screw, please see Technical Instructions.

Spare Parts

Cassette	Clamping Screw	TORX PLUS® Wrench
RIK224...	5.13 T20P	T20PQ

Cassette

RIK224

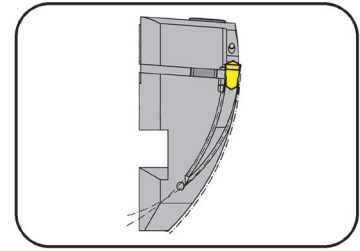

Outer groove \varnothing
Depth of groove up to
Width of groove

38 - 1000 mm
14 mm
5 - 6 mm

for Indexable insert

Type S224

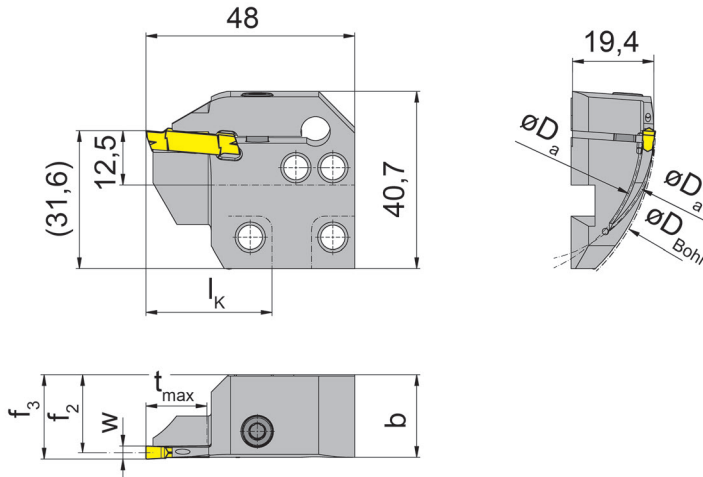

R = right hand version

Part number	D_{Bohr}	$D_{a \min}$	$D_{a \max}$	t_{\max}	b	f_2	f_3	w	l_k
RIK224.3847.05.IK	90	38	47	14	19.00	16.9	$f_2+w/2$	5	29
RIK224.4760.05.IK	90	47	60	14	19.00	17.4	$f_2+w/2$	5	29
RIK224.6075.05.IK	90	60	75	14	19.00	16.9	$f_2+w/2$	5	29
RIK224.7590.05.IK	90	75	90	14	19.00	16.9	$f_2+w/2$	5	29
RIK224.9013.05.IK	90	90	130	14	19.00	16.9	$f_2+w/2$	5	29
RIK224.1318.05.IK	130	130	180	14	19.00	16.9	$f_2+w/2$	5	29
RIK224.1830.05.IK	180	180	300	14	19.00	16.9	$f_2+w/2$	5	29
RIK224.3000.05.IK	300	300	1000	14	18.90	16.9	$f_2+w/2$	5	29
RIK224.6075.06.IK	90	60	75	14	19.00	16.4	$f_2+w/2$	6	29
RIK224.7590.06.IK	90	75	90	14	19.00	16.4	$f_2+w/2$	6	29
RIK224.9013.06.IK	90	90	130	14	19.00	16.4	$f_2+w/2$	6	29
RIK224.1318.06.IK	130	130	180	14	19.00	16.4	$f_2+w/2$	6	29
RIK224.1830.06.IK	180	180	300	14	19.00	16.4	$f_2+w/2$	6	29
RIK224.3000.06.IK	300	300	1000	14	18.75	16.4	$f_2+w/2$	6	29

For basic toolholder R...K1/R...K1IK and L...K2/L...K2.IK

Dimensions in mm

Further sizes upon request

Ordering note:

The fastening screw is combined with the basic toolholder - no separate order required.

For torque specification of the screw, please see Technical Instructions.

Spare Parts

Cassette	Clamping Screw	TORX PLUS® Wrench
RIK224...	5.13 T20P	T20PQ

Indexable insert

S224

with chip forming

Depth of groove up to
Width of groove

.709"
.118 - .157"

D2 precision sintered / *D2.G precision ground

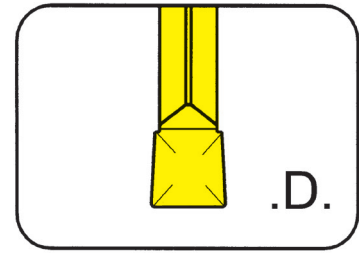

for Cassette

Type R/LAK224
R/LIK224

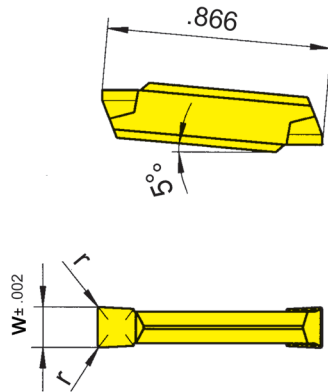

Indexability length ± .236"

Part number	w	r	Size	Carbide grades						
				H54	TF45	TF46	T122	T125	TN32	TN35
S224.0300.D2.G	.118	.008	03	▲	▲	▲	▲	▲	▲	▲
S224.0300.D2	.118	.008	03	▲	▲	▲	▲	▲	▲	▲
S224.0400.D2.G	.157	.008	04		▲	▲	▲	▲	▲	▲
S224.0400.D2	.157	.008	04	x	▲	▲	▲	▲	▲	▲
				P	●	●	●	●	●	●
				M	●	●	○	-	●	●
				K	-	●	●	-	●	●
				N	-	●	●	-	●	●
				S	-	●	○	-	●	●
				H	-	-	-	-	-	-

▲ on stock Δ 4 weeks x upon request

● recommended
○ alternative recommendation
- not suitable

□ uncoated grades
■ coated grades
■ brazed/Cermet

Dimensions in inch

Carbide grades

Indexable inserts can be used in right and left hand cassettes L/RAK224 and L/RIK224.

Indexable insert

S224

with chip forming

Depth of groove up to
Width of groove

.709"
.118 - .197"

precision sintered

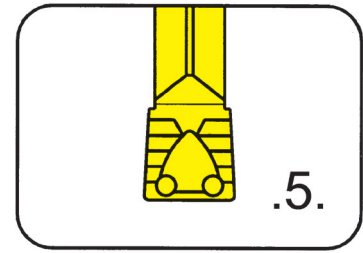

for Cassette

Type R/LAK224
R/LIK224

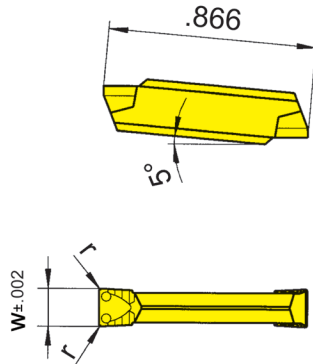

Indexability length ± .002"



Part number	w	r	Size	AL96	AS62	AS66	EG56	H54	TC92	TF45	TI25	TN32	TN35
S224.0300.52	.118	.008	03	x	▲	▲	▲	x	▲	▲	▲	▲	▲
S224.0300.54	.118	.016	03	▲	▲	▲	▲	x	▲	▲	▲	▲	▲
S224.0400.52	.157	.008	04	▲	▲	▲	▲	x	▲	▲	▲	▲	▲
S224.0400.54	.157	.016	04	▲	▲	▲	▲	x	▲	▲	▲	▲	▲
S224.0500.54	.197	.016	05	x	▲	▲	▲	x	▲	▲	▲	▲	▲
S224.0500.58	.197	.031	05	▲	▲	▲	▲	x	▲	x	▲	x	x
				P	●	●	●	●	●	●	●	●	●
				M	-	-	o	o	-	●	●	-	●
				K	●	-	●	o	-	-	●	●	-
				N	●	-	●	-	-	-	●	●	-
				S	-	-	o	-	-	-	●	●	-
				H	-	-	-	-	-	-	-	-	-

▲ on stock Δ 4 weeks x upon request
 ● recommended
 o alternative recommendation
 - not suitable
 uncoated grades
 coated grades
 brazed/Cermet

Dimensions in inch

Carbide grades

Indexable inserts can be used in right and left hand cassettes L/RAK224 and L/RIK224.

Indexable insert

S224

with chip forming

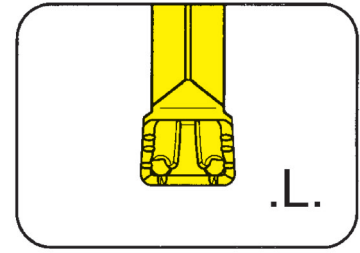

Depth of groove up to	.709"
Width of groove	.157 - .236"

precision sintered

for Cassette

Type R/LAK224
R/LIK224

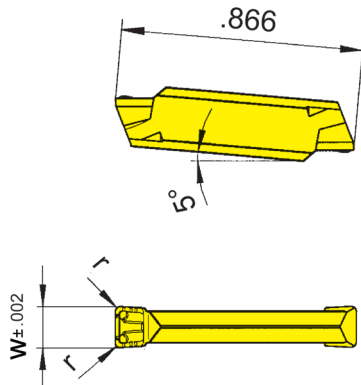

Indexability length ± .002"



Part number	w	r	Size	AL96	AS62	AS66	ASG6	TF42	Ti22
				S224.0400.L4	.157	.016	04	▲	▲
S224.0500.L4	.197	.016	05	▲	▲	▲	x	▲	▲
S224.0500.L6	.197	.024	05	▲	▲	▲	x	▲	▲
S224.0600.L4	.236	.016	06	▲	▲	▲	▲	▲	▲
S224.0600.L6	.236	.024	06	▲	▲	▲	x	▲	▲
				P	●	●	●	●	●
				M	-	-	o	o	-
				K	●	-	●	o	-
				N	●	-	●	-	-
				S	-	-	o	-	-
				H	-	-	-	-	-

▲ on stock Δ 4 weeks x upon request
 ● recommended
 o alternative recommendation
 - not suitable
 ■ uncoated grades
 ■ coated grades
 ■ brazed/Cermet

Dimensions in inch

Carbide grades

Indexable inserts can be used in right and left hand cassettes L/RAK224 and L/RIK224.



Toolholder

AU226/AU210/
LA226/RA226/
LA210/RA210

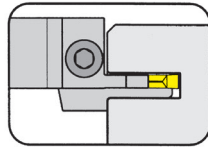

Page
T78-T85

Cassette

LIK220/RIK220/
LAK220/RAK220

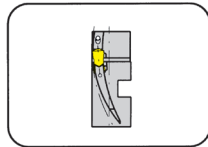

Page
T86-T89, T94-T97
Page
T90-T93, T98-T101

Indexable insert

S229

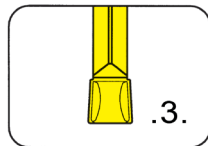

Page
T102

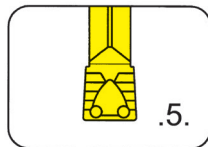

Page
T103

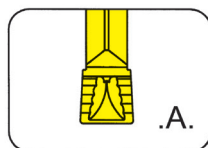

Page
T104-T105

Insert

229

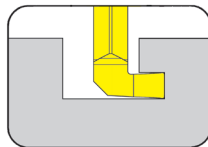

Page
T106

T

229



T

Toolholder with Inserts

Width of groove .157 - .315"

Toolholder

LAU226

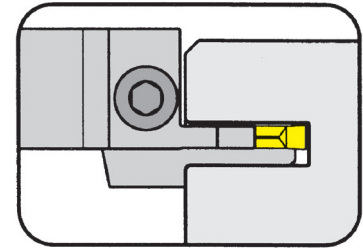

from outer groove \varnothing 3.740"
 Depth of groove up to .984"
 Width of groove .197"

for Indexable insert

Type 229
 S229

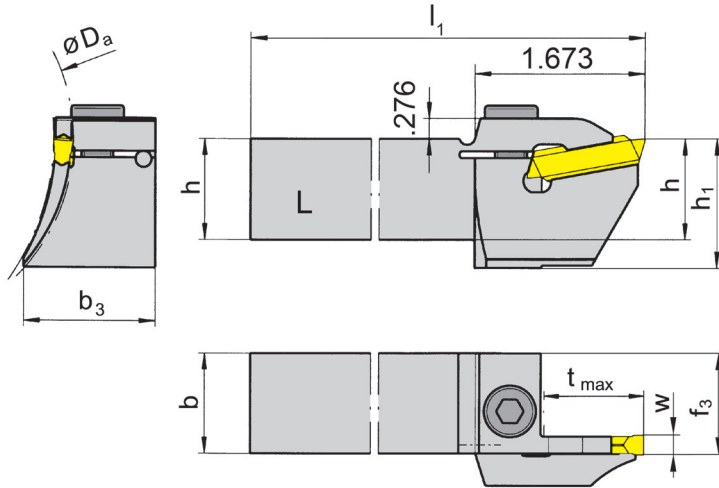

L = left hand version

Part number	h	b	l_1	h_1	f_3	t_{max}	$D_{a\ min}$	$D_{a\ max}$	b_3	Size
LAU226.07.1318.04	.750	.750	6.004	1.260	.807	.984	5.118	6.772	.984	04
LAU226.07.9513.04	.750	.750	6.004	1.260	.807	.984	3.740	4.803	1.024	04
LAU226.10.1318.04	1.000	1.000	6.004	1.260	1.020	.984	5.118	6.772	1.197	04
LAU226.10.9513.04	1.000	1.000	6.004	1.260	1.020	.984	3.740	4.803	1.236	04
LAU226.07.1318.05	.750	.750	6.004	1.260	.807	.984	5.118	6.693	.984	05
LAU226.07.9513.05	.750	.750	6.004	1.260	.807	.984	3.740	4.724	1.102	05
LAU226.10.1318.05	1.000	1.000	6.004	1.260	1.020	.984	5.118	6.693	1.197	05
LAU226.10.9513.05	1.000	1.000	6.004	1.260	1.020	.984	3.740	4.724	1.315	05

Further sizes upon request

Dimensions in inch

For torque specification of the screw, please see Technical Instructions.

Spare Parts

Toolholder	Clamping Screw	Allen wrench
LAU226...	218.3	SW6,0 DIN911

Toolholder

LA226

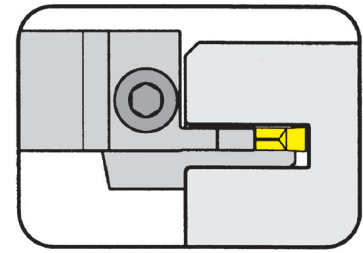

from outer groove \varnothing
Depth of groove up to
Width of groove

95 mm
25 mm
4 - 5 mm

for Indexable insert

Type 229
S229

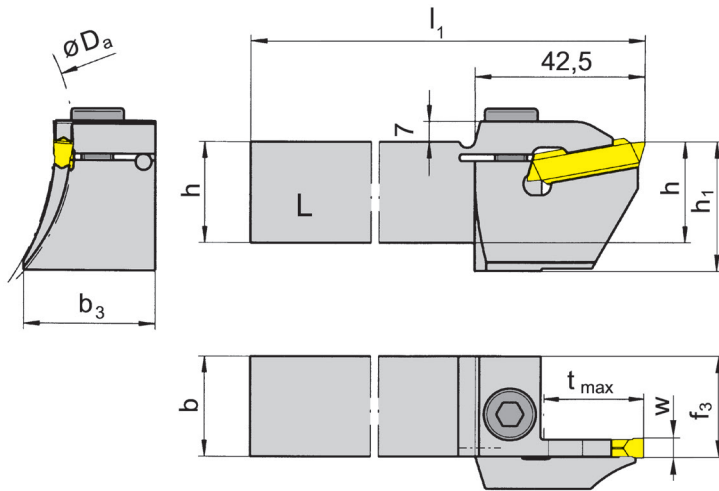

L = left hand version

Part number	h	b	l_1	h_1	f_3	t_{max}	$D_{a\ min}$	$D_{a\ min2}$	w	b_3	Size
LA226.20.1318.04	20	20	150	32	20.5	25	130	180	4	25	04
LA226.20.9513.04	20	20	150	32	20.5	25	95	130	4	26	04
LA226.25.1318.04	25	25	150	32	25.5	25	130	180	4	30	04
LA226.25.9513.04	25	25	150	32	25.5	25	95	130	4	31	04
LA226.20.1318.05	20	20	150	32	20.5	25	130	180	5	25	05
LA226.20.9513.05	20	20	150	32	20.5	25	95	130	5	28	05
LA226.25.1318.05	25	25	150	32	25.5	25	130	180	5	30	05
LA226.25.9513.05	25	25	150	32	25.5	25	95	130	5	33	05

Further sizes upon request

Dimensions in mm

For torque specification of the screw, please see Technical Instructions.

Spare Parts

Toolholder	Clamping Screw	Allen wrench
LA226...	218.3	SW6,0 DIN911

Toolholder

RAU226

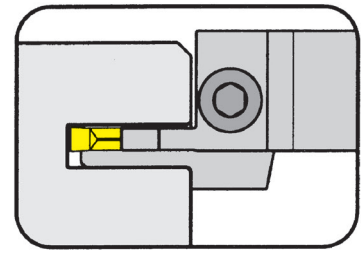

from outer groove \varnothing 3.740"
 Depth of groove up to .591"
 Width of groove .197"

for Indexable insert

Type 229
 S229

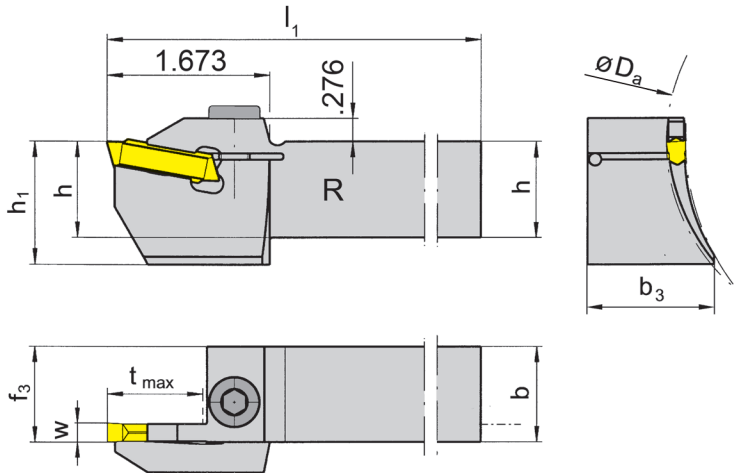

R = right hand version

Part number	h	b	l ₁	h ₁	f ₃	t _{max}	D _{a min}	D _{a max}	b ₃	Size
RAU226.07.1318.04	.750	.750	6.004	1.260	.807	.984	5.118	6.772	.984	04
RAU226.07.9513.04	.750	.750	6.004	1.260	.807	.984	3.740	4.803	1.024	04
RAU226.10.1318.04	1.000	1.000	6.004	1.260	1.020	.984	5.118	6.772	1.197	04
RAU226.10.9513.04	1.000	1.000	6.004	1.260	1.020	.984	3.740	4.803	1.236	04
RAU226.07.1318.05	.750	.750	6.004	1.260	.807	.984	5.118	6.693	.984	05
RAU226.07.9513.05	.750	.750	6.004	1.260	.807	.984	3.740	4.724	1.102	05
RAU226.10.1318.05	1.000	1.000	6.004	1.260	1.020	.984	5.118	6.693	1.197	05
RAU226.10.9513.05	1.000	1.000	6.004	1.260	1.020	.984	3.740	4.724	1.315	05

Further sizes upon request

Dimensions in inch

For torque specification of the screw, please see Technical Instructions.

Spare Parts

Toolholder	Clamping Screw	Allen wrench
RAU226...	218.3	SW6,0 DIN911

Toolholder

RA226

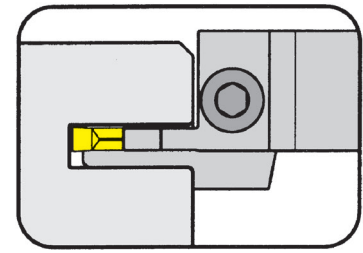

from outer groove \varnothing
Depth of groove up to
Width of groove

95 mm
25 mm
4 - 5 mm

for Indexable insert

Type 229
S229

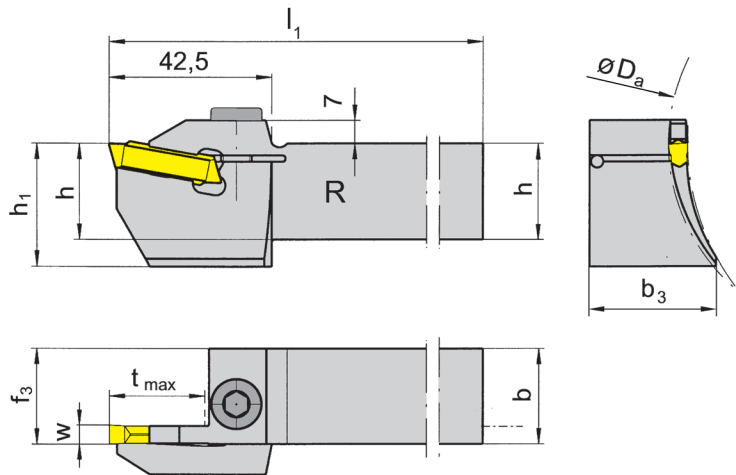

R = right hand version

Part number	h	b	l ₁	h ₁	f ₃	t _{max}	D _{a min}	D _{a min2}	w	b ₃	Size
RA226.20.1318.04	20	20	150	32	20.5	25	130	180	4	25	04
RA226.20.9513.04	20	20	150	32	20.5	25	95	130	4	26	04
RA226.25.1318.04	25	25	150	32	25.5	25	130	180	4	30	04
RA226.25.9513.04	25	25	150	32	25.5	25	95	130	4	31	04
RA226.20.1318.05	20	20	150	32	20.5	25	130	180	5	25	05
RA226.20.9513.05	20	20	150	32	20.5	25	95	130	5	28	05
RA226.25.1318.05	25	25	150	32	25.5	25	130	180	5	30	05
RA226.25.9513.05	25	25	150	32	25.5	25	95	130	5	33	05

Further sizes upon request

Dimensions in mm

For torque specification of the screw, please see Technical Instructions.

Spare Parts

Toolholder	Clamping Screw	Allen wrench
RA226...	218.3	SW6,0 DIN911

Toolholder

LAU210

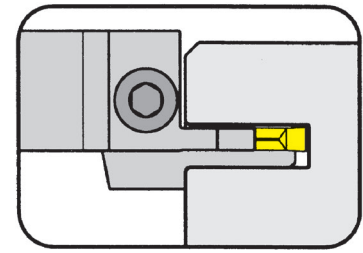

from outer groove \varnothing 3.740"
 Depth of groove up to .591"
 Width of groove .197"

for Indexable insert

Type 229
 S229

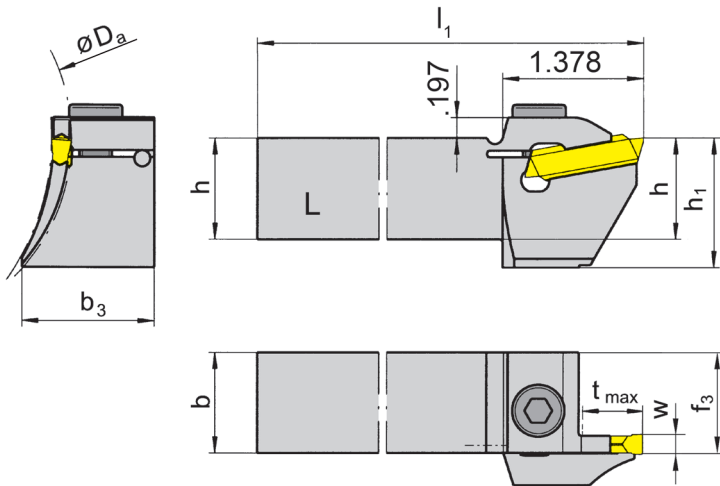

L = left hand version

Part number	h	b	l_1	h_1	b_3	f_3	t_{max}	$D_{a\ min}$	$D_{a\ max}$	Size
LAU210.07.1318.14	.750	.750	6.004	1.260	.984	.807	.591	5.118	6.772	04
LAU210.07.9513.14	.750	.750	6.004	1.260	1.024	.807	.591	3.740	4.803	04
LAU210.10.1318.14	1.000	1.000	6.004	1.260	1.197	1.020	.591	5.118	6.772	04
LAU210.10.9513.14	1.000	1.000	6.004	1.260	1.236	1.020	.591	3.740	4.803	04
LAU210.07.1318.15	.750	.750	6.004	1.260	.984	.807	.591	5.118	6.693	05
LAU210.07.9513.15	.750	.750	6.004	1.260	1.102	.807	.591	3.740	4.724	05
LAU210.10.1318.15	1.000	1.000	6.004	1.260	1.197	1.020	.591	5.118	6.693	05
LAU210.10.9513.15	1.000	1.000	6.004	1.260	1.315	1.020	.591	3.740	4.724	05

Further sizes upon request

Dimensions in inch

For torque specification of the screw, please see Technical Instructions.

Spare Parts

Toolholder	Clamping Screw	Allen wrench
LAU210...	218.3	SW6,0 DIN911

Toolholder

LA210

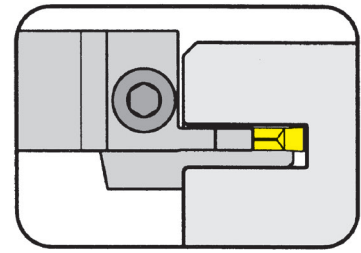

from outer groove \varnothing
Depth of groove up to
Width of groove

95 mm
15 mm
4 - 8 mm

for Indexable insert

Type 229
S229

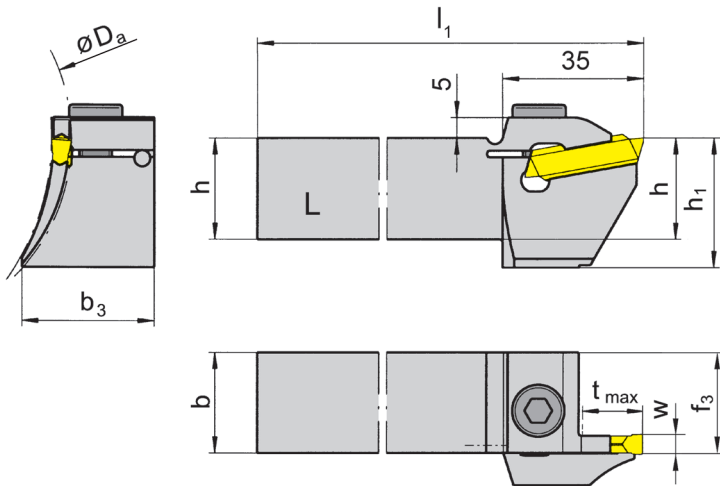

L = left hand version

Part number	h	b	l_1	h_1	b_3	f_3	t_{max}	$D_{a \min}$	$D_{a \max}$	w	Size
LA210.20.1318.14	20	20	150	32	25.0	20.5	15	130	180	4	04
LA210.20.9513.14	20	20	150	32	26.0	20.5	15	95	130	4	04
LA210.25.1318.14	25	25	150	32	30.0	25.5	15	130	180	4	04
LA210.25.9513.14	25	25	150	32	31.0	25.5	15	95	130	4	04
LA210.20.1318.15	20	20	150	32	25.0	20.5	15	130	180	5	05
LA210.20.9513.15	20	20	150	32	28.0	20.5	15	95	130	5	05
LA210.25.1318.15	25	25	150	32	30.0	25.5	15	130	180	5	05
LA210.25.9513.15	25	25	150	32	33.0	25.5	15	95	130	5	05
LA210.25.1318.18	25	25	150	32	30.5	25.5	15	130	180	8	08

Further sizes upon request

Dimensions in mm

For torque specification of the screw, please see Technical Instructions.

Spare Parts

Toolholder	Clamping Screw	Allen wrench
LA210...	218.3	SW6,0 DIN911

Toolholder

RAU210

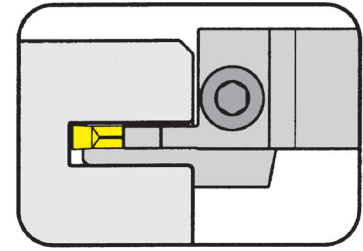

from outer groove \emptyset 3.740"
 Depth of groove up to .591"
 Width of groove .197"

for Indexable insert

Type 229
 S229

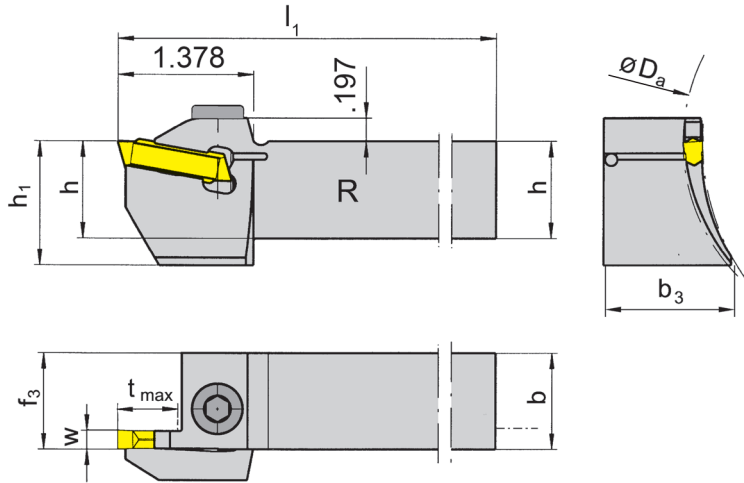

R = right hand version

Part number	h	b	l ₁	h ₁	b ₃	f ₃	t _{max}	D _{a min}	D _{a max}	Size
RAU210.07.1318.14	.750	.750	6.004	1.260	.984	.807	.591	5.118	6.772	04
RAU210.07.9513.14	.750	.750	6.004	1.260	1.024	.807	.591	3.740	4.803	04
RAU210.10.1318.14	1.000	1.000	6.004	1.260	1.197	1.020	.591	5.118	6.772	04
RAU210.10.9513.14	1.000	1.000	6.004	1.260	1.236	1.020	.591	3.740	4.803	04
RAU210.07.1318.15	.750	.750	6.004	1.260	.984	.807	.591	5.118	6.693	05
RAU210.07.9513.15	.750	.750	6.004	1.260	1.102	.807	.591	3.740	4.724	05
RAU210.10.1318.15	1.000	1.000	6.004	1.260	1.197	1.020	.591	5.118	6.693	05
RAU210.10.9513.15	1.000	1.000	6.004	1.260	1.315	1.020	.591	3.740	4.724	05

Further sizes upon request

Dimensions in inch

For torque specification of the screw, please see Technical Instructions.

Spare Parts

Toolholder	Clamping Screw	Allen wrench
RAU210...	218.3	SW6,0 DIN911

Toolholder

RA210

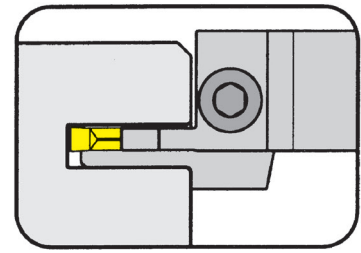

from outer groove \varnothing
Depth of groove up to
Width of groove

95 mm
15 mm
4 - 8 mm

for Indexable insert

Type 229
S229

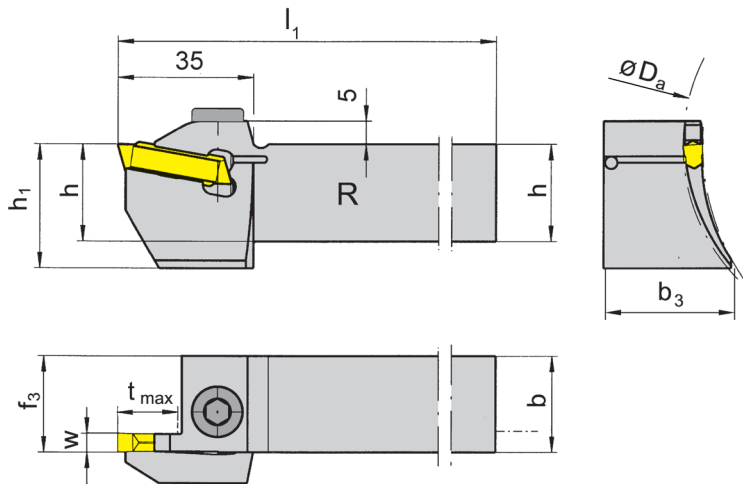

R = right hand version

Part number	h	b	l ₁	h ₁	b ₃	f ₃	t _{max}	D _{a min}	D _{a max}	w	Size
RA210.20.1318.14	20	20	150	32	25.0	20.5	15	130	180	4	04
RA210.20.9513.14	20	20	150	32	26.0	20.5	15	95	130	4	04
RA210.25.1318.14	25	25	150	32	30.0	25.5	15	130	180	4	04
RA210.25.9513.14	25	25	150	32	31.0	25.5	15	95	130	4	04
RA210.20.1318.15	20	20	150	32	25.0	20.5	15	130	180	5	05
RA210.25.1318.15	25	25	150	32	30.0	25.5	15	130	180	5	05
RA210.32.1318.15	32	32	150	32	37.0	32.5	15	130	180	5	05
RA210.20.9513.15	20	20	150	32	28.0	20.5	15	95	130	5	05
RA210.25.9513.15	25	25	150	32	33.0	25.5	15	95	130	5	05
RA210.25.1318.18	25	25	150	32	30.5	25.5	15	130	180	8	08

Further sizes upon request

Dimensions in mm

For torque specification of the screw, please see Technical Instructions.

Spare Parts

Toolholder	Clamping Screw	Allen wrench
RA210...	218.3	SW6,0 DIN911

Cassette

LIK220

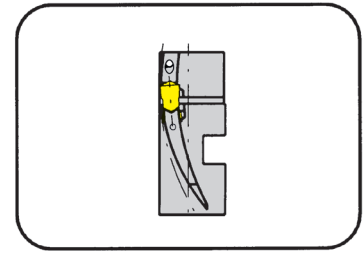

Outer groove \varnothing
Depth of groove up to
Width of groove

60 - 300 mm
15 mm
4 - 5 mm

for Indexable insert

Type 229
S229

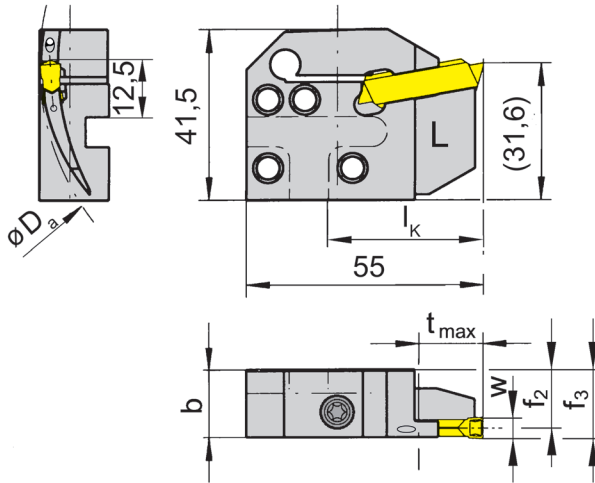

L = left hand version

Part number	$D_{a \text{ min}}$	$D_{a \text{ max}}$	t_{max}	b	f_2	f_3	w	l_k
LIK220.6575.14.IK	65	75	10	15.7	14.4	$f_2+w/2$	4	36
LIK220.7595.14.IK	75	95	15	15.7	14.4	$f_2+w/2$	4	36
LIK220.9513.14.IK	95	130	15	15.7	14.4	$f_2+w/2$	4	36
LIK220.1318.14.IK	130	180	15	15.7	14.4	$f_2+w/2$	4	36
LIK220.1830.14.IK	180	300	15	15.7	14.4	$f_2+w/2$	4	36
LIK220.6075.15.IK	60	75	10	15.7	13.9	$f_2+w/2$	5	36
LIK220.7595.15.IK	75	95	15	15.7	13.9	$f_2+w/2$	5	36
LIK220.9513.15.IK	95	130	15	15.7	13.9	$f_2+w/2$	5	36
LIK220.1318.15.IK	130	180	15	15.7	13.9	$f_2+w/2$	5	36
LIK220.1830.15.IK	130	180	15	15.7	13.9	$f_2+w/2$	5	36

For basic toolholder L...K1 and R...K2

Dimensions in mm

Further sizes upon request

Ordering note:

The fastening screw is combined with the basic toolholder - no separate order required.

For torque specification of the screw, please see Technical Instructions.

Spare Parts

Cassette	Clamping Screw	TORX PLUS® Wrench
LIK220...	6.23T25P	T25PQ

Cassette

LIK220

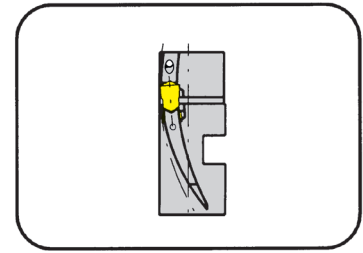

Outer groove \varnothing
Depth of groove up to
Width of groove

60 - 300 mm
15 mm
6 mm

for Indexable insert

Type 229
S229

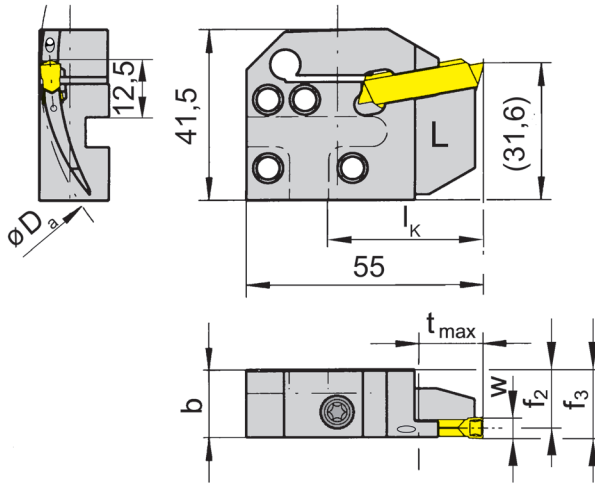

L = left hand version

Part number	$D_{a \text{ min}}$	$D_{a \text{ max}}$	t_{max}	b	f_2	f_3	w	l_K
LIK220.6075.16.IK	130	180	10	15.7	13.4	$f_2+w/2$	6	36
LIK220.7595.16.IK	75	95	15	15.7	13.4	$f_2+w/2$	6	36
LIK220.9513.16.IK	95	130	15	15.7	13.4	$f_2+w/2$	6	36
LIK220.1318.16.IK	130	180	15	15.7	13.4	$f_2+w/2$	6	36
LIK220.1830.16.IK	180	300	15	15.7	13.4	$f_2+w/2$	6	36

For basic toolholder L...K1 and R...K2

Dimensions in mm

Further sizes upon request

Ordering note:

The fastening screw is combined with the basic toolholder - no separate order required.

For torque specification of the screw, please see Technical Instructions.

Spare Parts

Cassette	Clamping Screw	TORX PLUS® Wrench
LIK220...	6.23T25P	T25PQ



Cassette

RIK220

Outer groove Ø
Depth of groove up to
Width of groove

60 - 300 mm
15 mm
4 - 5 mm

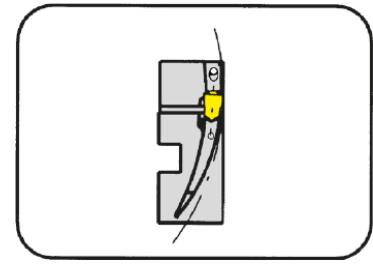

for Indexable insert

Type 229
S229

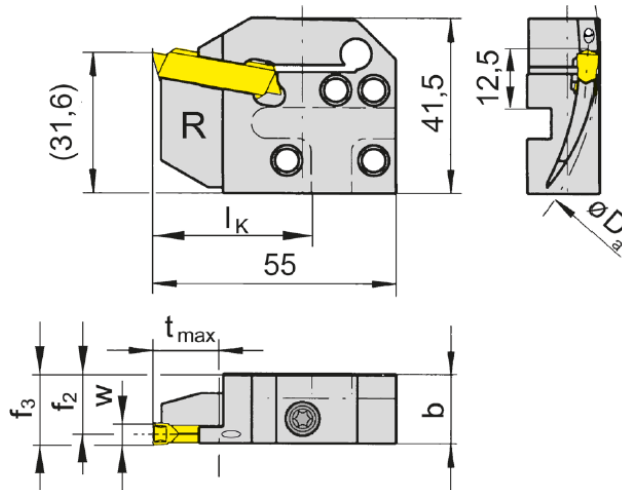

R = right hand version

Part number	D _{a min}	D _{a max}	t _{max}	b	f ₂	f ₃	w	l _k
RIK220.6575.14.IK	65	75	10	15.7	14.4	f ₂ +w/2	4	36
RIK220.7595.14.IK	75	95	15	15.7	14.4	f ₂ +w/2	4	36
RIK220.9513.14.IK	95	130	15	15.7	14.4	f ₂ +w/2	4	36
RIK220.1830.14.IK	180	300	15	15.7	14.4	f ₂ +w/2	4	36
RIK220.1318.14.IK	130	180	15	15.7	14.4	f ₂ +w/2	4	36
RIK220.6075.15.IK	60	75	10	15.7	13.9	f ₂ +w/2	5	36
RIK220.7595.15.IK	75	95	15	15.7	13.9	f ₂ +w/2	5	36
RIK220.9513.15.IK	95	130	15	15.7	13.9	f ₂ +w/2	5	36
RIK220.1318.15.IK	130	180	15	15.7	13.9	f ₂ +w/2	5	36
RIK220.1830.15.IK	130	180	15	15.7	13.9	f ₂ +w/2	5	36

For basic toolholder R...K1 and L...K2

Dimensions in mm

Further sizes upon request

Ordering note:

The fastening screw is combined with the basic toolholder - no separate order required.

For torque specification of the screw, please see Technical Instructions.

Spare Parts

Cassette	Clamping Screw	TORX PLUS® Wrench
RIK220...	6.23T25P	T25PQ

Cassette

RIK220

Outer groove Ø
Depth of groove up to
Width of groove

60 - 300 mm
15 mm
6 mm

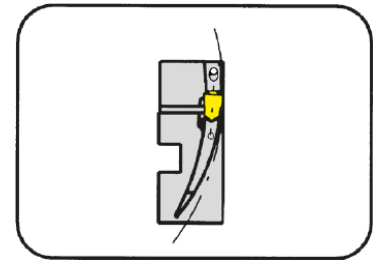

for Indexable insert

Type 229
S229

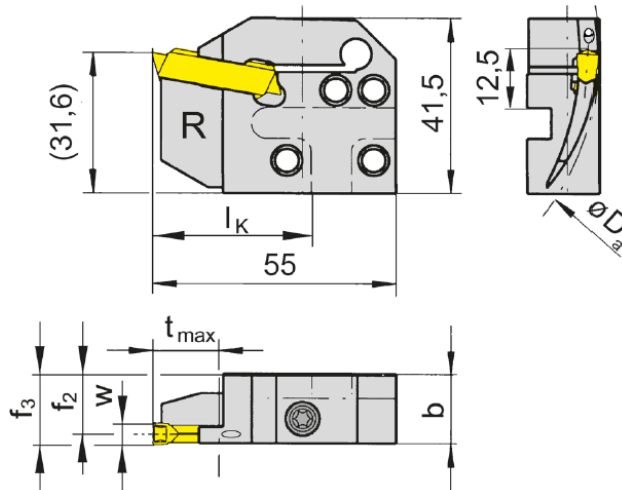

R = right hand version

Part number	D _{a min}	D _{a max}	t _{max}	b	f ₂	f ₃	w	l _k
RIK220.6075.16.IK	60	75	10	15.7	13.4	f ₂ +w/2	6	36
RIK220.7595.16.IK	75	95	15	15.7	13.4	f ₂ +w/2	6	36
RIK220.9513.16.IK	95	130	15	15.7	13.4	f ₂ +w/2	6	36
RIK220.1318.16.IK	130	180	15	15.7	13.4	f ₂ +w/2	6	36
RIK220.1830.16.IK	180	300	15	15.7	13.4	f ₂ +w/2	6	36

For basic toolholder R...K1 and L...K2

Dimensions in mm

Further sizes upon request

Ordering note:

The fastening screw is combined with the basic toolholder - no separate order required.

For torque specification of the screw, please see Technical Instructions.

Spare Parts

Cassette	Clamping Screw	TORX PLUS® Wrench
RIK220...	6.23T25P	T25PQ

Cassette

LAK220

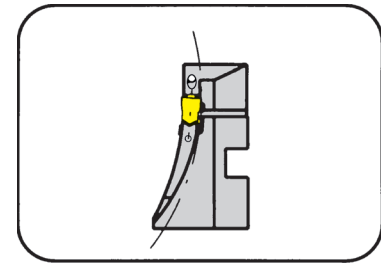

Outer groove \varnothing
Depth of groove up to
Width of groove

60 - 300 mm
15 mm
4 - 5 mm

for Indexable insert

Type 229
S229

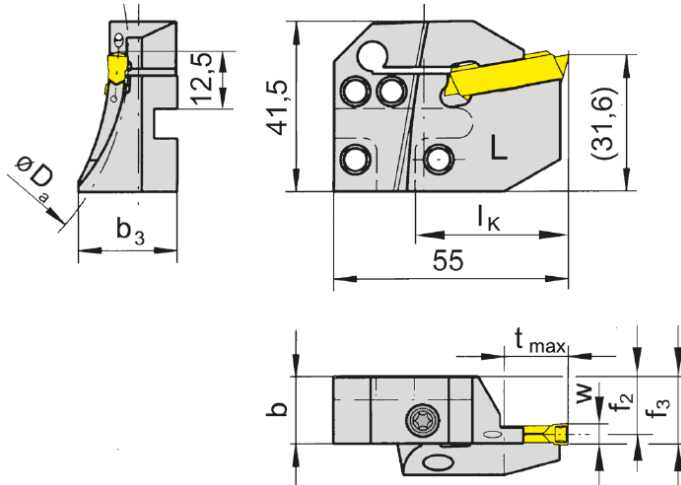

L = left hand version

Part number	$D_{a \min}$	$D_{a \max}$	t_{\max}	b	b_3	f_2	f_3	w_{\max}	l_K
LAK220.6575.14.IK	65	75	10	15.7	23.0	14.4	$f_2+w/2$	4	36
LAK220.7595.14.IK	75	95	15	15.7	23.0	14.4	$f_2+w/2$	4	36
LAK220.9513.14.IK	95	130	15	15.7	21.2	14.4	$f_2+w/2$	4	36
LAK220.1318.14.IK	130	180	15	15.7	21.2	14.4	$f_2+w/2$	4	36
LAK220.1830.14.IK	180	300	15	15.7	19.0	14.4	$f_2+w/2$	4	36
LAK220.6075.15.IK	60	75	10	15.7	23.0	13.9	$f_2+w/2$	5	36
LAK220.7595.15.IK	75	95	15	15.7	23.0	13.9	$f_2+w/2$	5	36
LAK220.9513.15.IK	95	130	15	15.7	23.0	13.9	$f_2+w/2$	5	36
LAK220.1318.15.IK	130	180	15	15.7	21.2	13.9	$f_2+w/2$	5	36
LAK220.1830.15.IK	180	300	15	15.7	19.0	13.9	$f_2+w/2$	5	36

For basic toolholder L...K1 and R...K2

Dimensions in mm

Further sizes upon request

Ordering note:

The fastening screw is combined with the basic toolholder - no separate order required.

For torque specification of the screw, please see Technical Instructions.

Spare Parts

Cassette	Clamping Screw	TORX PLUS® Wrench
LAK220...	6.23T25P	T25PQ

Cassette

LAK220

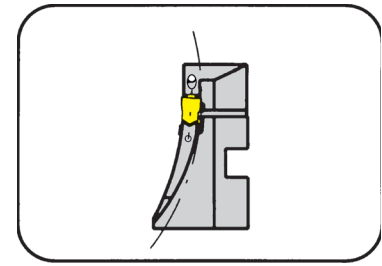

Outer groove \varnothing
Depth of groove up to
Width of groove

60 - 300 mm
15 mm
6 mm

for Indexable insert

Type 229
S229

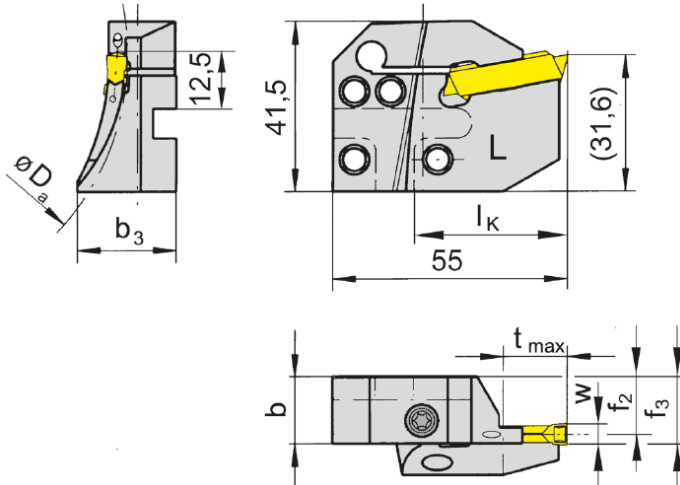

L = left hand version

Part number	$D_{a \min}$	$D_{a \max}$	t_{\max}	b	b_3	f_2	f_3	w_{\max}	l_K
LAK220.6075.16.IK	60	75	10	15.7	23.0	13.4	$f_2+w/2$	6	36
LAK220.7595.16.IK	75	95	15	15.7	23.0	13.4	$f_2+w/2$	6	36
LAK220.9513.16.IK	95	130	15	15.7	23.0	13.4	$f_2+w/2$	6	36
LAK220.1318.16.IK	130	180	15	15.7	21.2	13.4	$f_2+w/2$	6	36
LAK220.1830.16.IK	180	300	15	15.7	19.0	13.4	$f_2+w/2$	6	36

For basic toolholder L...K1 and R...K2

Dimensions in mm

Further sizes upon request

Ordering note:

The fastening screw is combined with the basic toolholder - no separate order required.

For torque specification of the screw, please see Technical Instructions.

Spare Parts

Cassette	Clamping Screw	TORX PLUS® Wrench
LAK220...	6.23T25P	T25PQ

Cassette

RAK220

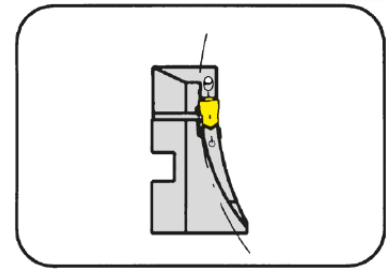

Outer groove \varnothing
Depth of groove up to
Width of groove

60 - 300 mm
15 mm
4 - 5 mm

for Indexable insert

Type 229
S229

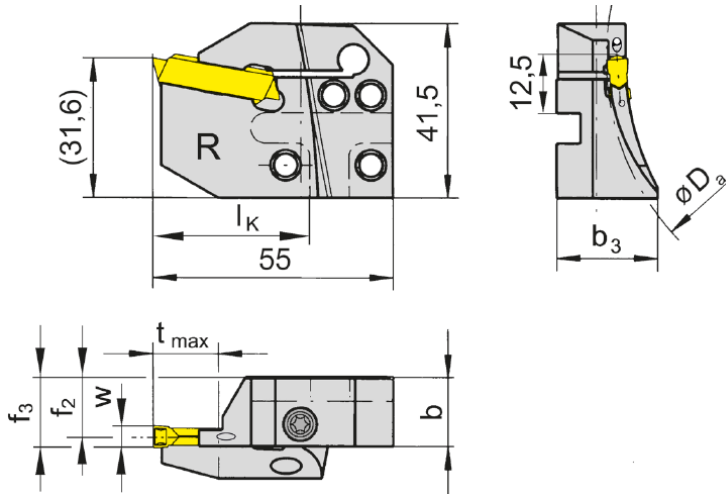

R = right hand version

Part number	$D_{a \min}$	$D_{a \max}$	t_{\max}	b	b_3	f_2	f_3	w_{\max}	l_k
RAK220.6575.14.IK	65	75	10	15.7	23.0	14.4	$f_2+w/2$	4	36
RAK220.7595.14.IK	75	95	15	15.7	23.0	14.4	$f_2+w/2$	4	36
RAK220.9513.14.IK	95	130	15	15.7	21.2	14.4	$f_2+w/2$	4	36
RAK220.1318.14.IK	130	180	15	15.7	21.2	14.4	$f_2+w/2$	4	36
RAK220.1830.14.IK	180	300	15	15.7	19.0	14.4	$f_2+w/2$	4	36
RAK220.6075.15.IK	60	75	10	15.7	23.0	13.4	$f_2+w/2$	5	36
RAK220.7595.15.IK	75	95	15	15.7	23.0	13.9	$f_2+w/2$	5	36
RAK220.9513.15.IK	95	130	15	15.7	23.0	13.9	$f_2+w/2$	5	36
RAK220.1318.15.IK	130	180	15	15.7	21.2	13.9	$f_2+w/2$	5	36
RAK220.1830.15.IK	180	300	15	15.7	19.0	13.9	$f_2+w/2$	5	36

For basic toolholder R...K1 and L...K2

Dimensions in mm

Further sizes upon request

Ordering note:

The fastening screw is combined with the basic toolholder - no separate order required.

For torque specification of the screw, please see Technical Instructions.

Spare Parts

Cassette	Clamping Screw	TORX PLUS® Wrench
RAK220...	6.23T25P	T25PQ

Cassette

RAK220

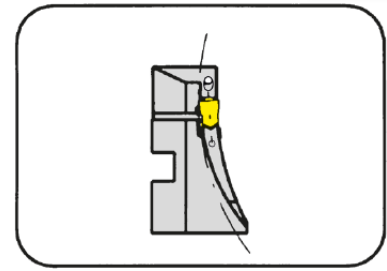

Outer groove Ø
Depth of groove up to
Width of groove

60 - 300 mm
15 mm
6 mm

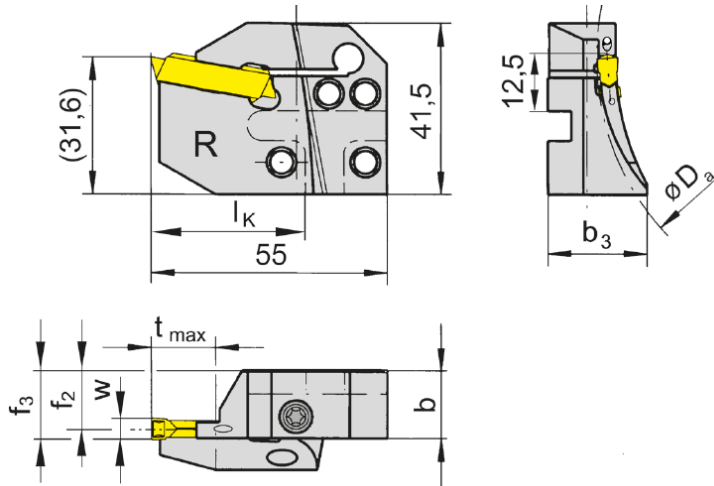

for Indexable insert

Type 229
S229

R = right hand version

Part number	D _{a min}	D _{a max}	t _{max}	b	b ₃	f ₂	f ₃	w _{max}	l _k
RAK220.6075.16.IK	60	75	10	15.7	23.0	13.4	f ₂ +w/2	6	36
RAK220.7595.16.IK	75	95	15	15.7	23.0	13.4	f ₂ +w/2	6	36
RAK220.9513.16.IK	95	130	15	15.7	23.0	13.4	f ₂ +w/2	6	36
RAK220.1318.16.IK	130	180	15	15.7	21.2	13.4	f ₂ +w/2	6	36
RAK220.1830.16.IK	180	300	15	15.7	19.0	13.4	f ₂ +w/2	6	36

For basic toolholder R...K1 and L...K2

Dimensions in mm

Further sizes upon request

Ordering note:

The fastening screw is combined with the basic toolholder - no separate order required.

For torque specification of the screw, please see Technical Instructions.

Spare Parts

Cassette	Clamping Screw	TORX PLUS® Wrench
RAK220...	6.23T25P	T25PQ

Cassette

LIK220

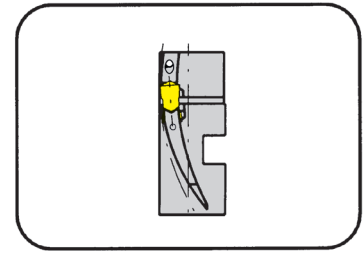

Outer groove \varnothing
Depth of groove up to
Width of groove

60 - 1000 mm
25 mm
4 - 5 mm

for Indexable insert

Type 229
S229

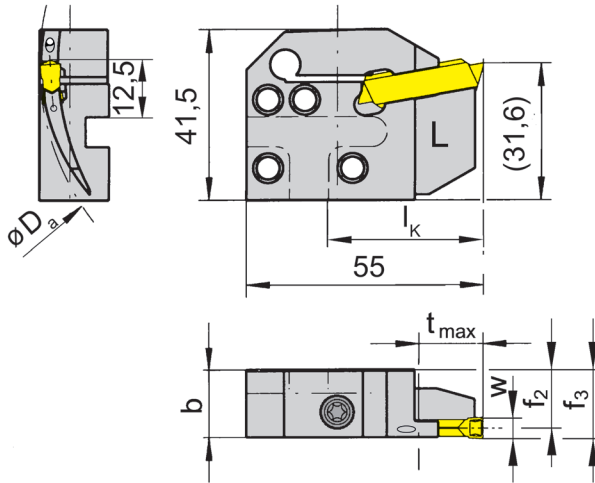

L = left hand version

Part number	$D_{a \min}$	$D_{a \max}$	t_{\max}	b	f_2	f_3	w	l_k
LIK220.6575.04.IK	65	75	10	15.7	14.4	$f_2+w/2$	4	36
LIK220.7595.04.IK	75	95	15	15.7	14.4	$f_2+w/2$	4	36
LIK220.9513.04.IK	95	130	25	15.7	14.4	$f_2+w/2$	4	36
LIK220.1318.04.IK	130	180	25	15.7	14.4	$f_2+w/2$	4	36
LIK220.1830.04.IK	180	300	25	15.7	14.4	$f_2+w/2$	4	36
LIK220.3000.04.IK	300	1000	25	15.7	14.4	$f_2+w/2$	4	36
LIK220.6075.05.IK	60	75	10	15.7	13.9	$f_2+w/2$	5	36
LIK220.7595.05.IK	75	95	17	15.7	13.9	$f_2+w/2$	5	36
LIK220.9513.05.IK	95	130	25	15.7	13.9	$f_2+w/2$	5	36
LIK220.1318.05.IK	130	180	25	15.7	13.9	$f_2+w/2$	5	36
LIK220.1830.05.IK	180	300	25	15.7	13.9	$f_2+w/2$	5	36
LIK220.3000.05.IK	300	1000	25	15.7	13.9	$f_2+w/2$	5	36

For basic toolholder L...K1 and R...K2

Dimensions in mm

Further sizes upon request

Ordering note:

The fastening screw is combined with the basic toolholder - no separate order required.

For torque specification of the screw, please see Technical Instructions.

Spare Parts

Cassette	Clamping Screw	TORX PLUS® Wrench
LIK220...	6.23T25P	T25PQ

Cassette

LIK220

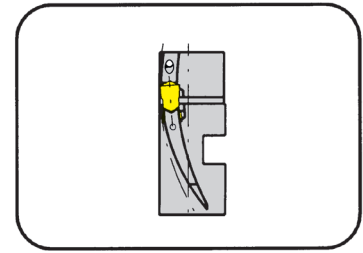

Outer groove \varnothing
Depth of groove up to
Width of groove

60 - 1000 mm
25 mm
6 mm

for Indexable insert

Type 229
S229

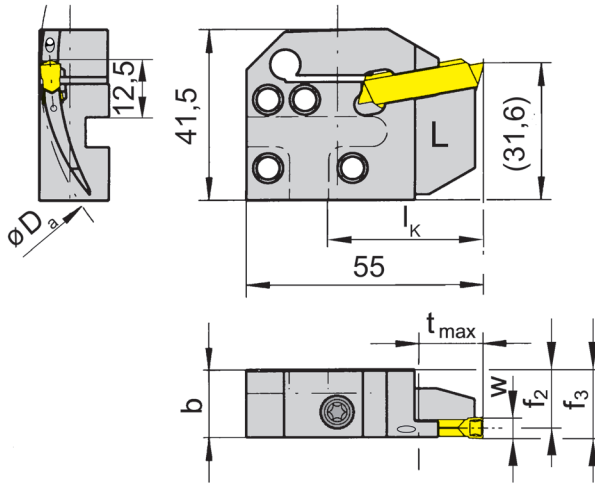

L = left hand version

Part number	$D_{a \min}$	$D_{a \max}$	t_{\max}	b	f_2	f_3	w	l_K
LIK220.6075.06.IK	60	75	10	15.7	13.4	$f_2+w/2$	6	36
LIK220.7595.06.IK	75	95	17	15.7	13.4	$f_2+w/2$	6	36
LIK220.9513.06.IK	95	130	25	15.7	13.4	$f_2+w/2$	6	36
LIK220.1318.06.IK	130	180	25	15.7	13.4	$f_2+w/2$	6	36
LIK220.1830.06.IK	180	300	25	15.7	13.4	$f_2+w/2$	6	36
LIK220.3000.06.IK	300	1000	25	15.7	13.4	$f_2+w/2$	6	36

For basic toolholder L...K1 and R...K2

Dimensions in mm

Further sizes upon request

Ordering note:

The fastening screw is combined with the basic toolholder - no separate order required.

For torque specification of the screw, please see Technical Instructions.

Spare Parts

Cassette	Clamping Screw	TORX PLUS® Wrench
LIK220...	6.23T25P	T25PQ



Cassette

RIK220

Outer groove Ø
Depth of groove up to
Width of groove

60 - 1000 mm
25 mm
4 - 5 mm

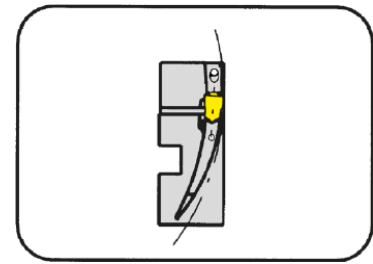

for Indexable insert

Type 229
S229

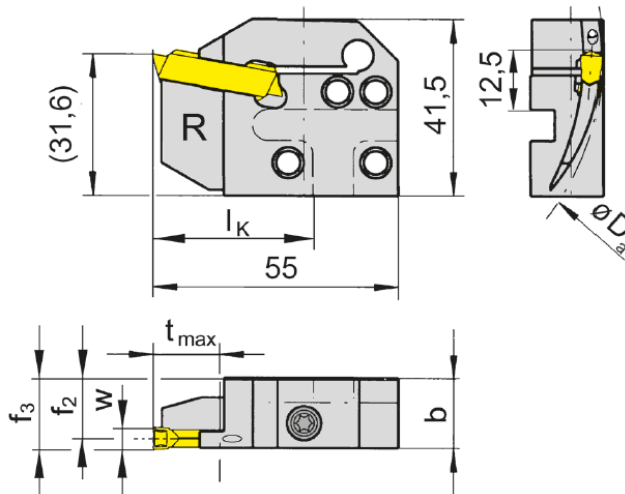

R = right hand version

Part number	D _{a min}	D _{a max}	t _{max}	b	f ₂	f ₃	w	l _k
RIK220.6575.04.IK	65	75	10	15.7	14.4	f ₂ +w/2	4	36
RIK220.7595.04.IK	75	95	15	15.7	14.4	f ₂ +w/2	4	36
RIK220.9513.04.IK	95	130	25	15.7	14.4	f ₂ +w/2	4	36
RIK220.1318.04.IK	130	180	25	15.7	14.4	f ₂ +w/2	4	36
RIK220.1830.04.IK	180	300	25	15.7	14.4	f ₂ +w/2	4	36
RIK220.3000.04.IK	300	1000	25	15.7	14.4	f ₂ +w/2	4	36
RIK220.6075.05.IK	60	75	10	15.7	13.9	f ₂ +w/2	5	36
RIK220.7595.05.IK	75	95	17	15.7	13.9	f ₂ +w/2	5	36
RIK220.9513.05.IK	95	130	25	15.7	13.9	f ₂ +w/2	5	36
RIK220.1318.05.IK	130	180	25	15.7	13.9	f ₂ +w/2	5	36
RIK220.1830.05.IK	180	300	25	15.7	13.9	f ₂ +w/2	5	36
RIK220.3000.05.IK	300	1000	25	15.7	13.9	f ₂ +w/2	5	36

For basic toolholder R...K1 and L...K2

Dimensions in mm

Further sizes upon request

Ordering note:

The fastening screw is combined with the basic toolholder - no separate order required.

For torque specification of the screw, please see Technical Instructions.

Spare Parts

Cassette	Clamping Screw	TORX PLUS® Wrench
RIK220...	6.23T25P	T25PQ

Cassette

RIK220

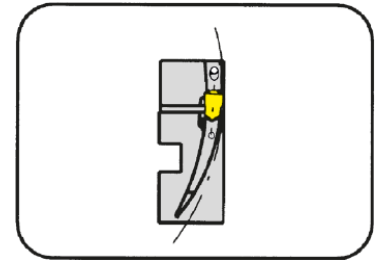

Outer groove \emptyset
Depth of groove
Width of groove

60 - 1000 mm
25 mm
6 mm

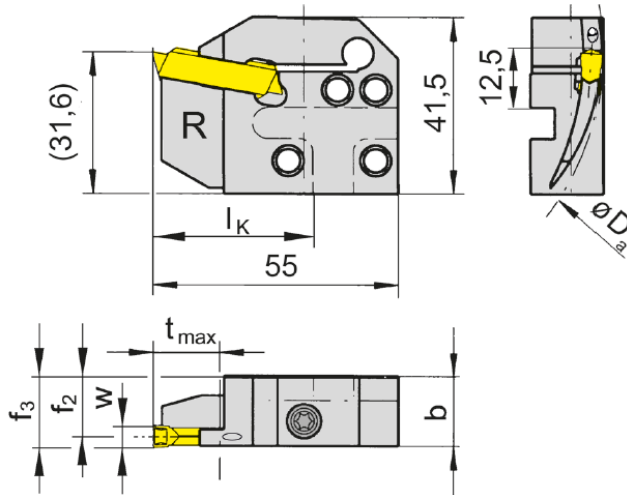

R = right hand version

for Indexable insert

Type 229
S229

Part number	$D_{a \text{ min}}$	$D_{a \text{ max}}$	t_{max}	b	f_2	f_3	w	l_k
RIK220.6075.06.IK	60	75	10	15.7	13.4	$f_2 + w/2$	6	36
RIK220.7595.06.IK	75	95	17	15.7	13.4	$f_2 + w/2$	6	36
RIK220.9513.06.IK	95	130	25	15.7	13.4	$f_2 + w/2$	6	36
RIK220.1318.06.IK	130	180	25	15.7	13.4	$f_2 + w/2$	6	36
RIK220.3000.06.IK	300	1000	25	15.7	13.4	$f_2 + w/2$	6	36

For basic toolholder R...K1 and L...K2

Dimensions in mm

Further sizes upon request

Ordering note:

The fastening screw is combined with the basic toolholder - no separate order required.

For torque specification of the screw, please see Technical Instructions.

Spare Parts

Cassette	Clamping Screw	TORX PLUS® Wrench
RIK220...	6.23T25P	T25PQ

Cassette

LAK220

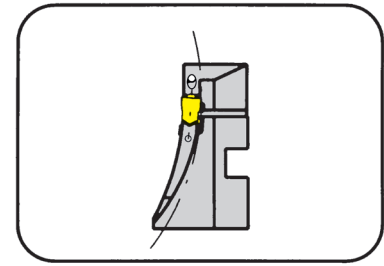

Outer groove \varnothing
Depth of groove up to
Width of groove

60 - 1000 mm
25 mm
4 - 5 mm

for Indexable insert

Type 229
S229

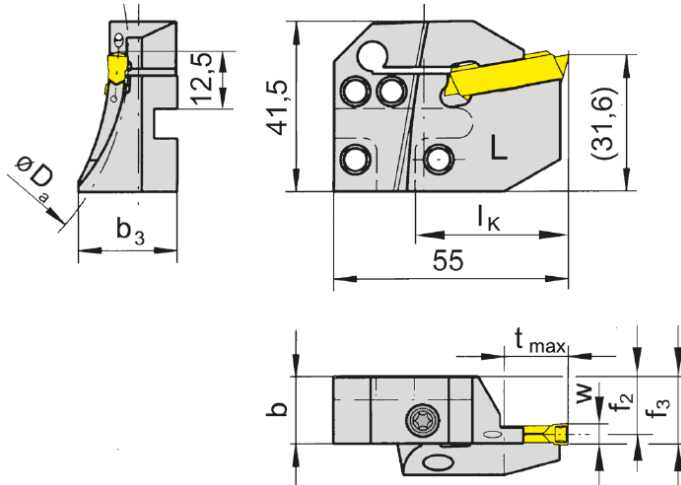

L = left hand version

Part number	$D_{a \min}$	$D_{a \max}$	t_{\max}	b	b_3	f_2	f_3	w_{\max}	l_K
LAK220.6575.04.IK	65	75	10	15.7	23.0	14.4	$f_2+w/2$	4	36
LAK220.7595.04.IK	75	95	15	15.7	23.0	14.4	$f_2+w/2$	4	36
LAK220.9513.04.IK	95	122	25	15.7	21.2	14.4	$f_2+w/2$	4	36
LAK220.1318.04.IK	130	180	25	15.7	21.2	14.4	$f_2+w/2$	4	36
LAK220.1830.04.IK	180	300	25	15.7	19.0	14.4	$f_2+w/2$	4	36
LAK220.3000.04.IK	300	1000	25	15.7	16.8	14.4	$f_2+w/2$	4	36
LAK220.6075.05.IK	60	75	10	15.7	23.0	13.9	$f_2+w/2$	5	36
LAK220.7595.05.IK	75	95	17	15.7	23.0	13.9	$f_2+w/2$	5	36
LAK220.9513.05.IK	95	120	25	15.7	23.0	13.9	$f_2+w/2$	5	36
LAK220.1318.05.IK	130	180	25	15.7	21.2	13.9	$f_2+w/2$	5	36
LAK220.1830.05.IK	180	300	25	15.7	19.0	13.9	$f_2+w/2$	5	36
LAK220.3000.05.IK	300	1000	25	15.7	16.8	13.9	$f_2+w/2$	5	36

For basic toolholder L...K1 and R...K2

Dimensions in mm

Further sizes upon request

Ordering note:

The fastening screw is combined with the basic toolholder - no separate order required.

For torque specification of the screw, please see Technical Instructions.

Spare Parts

Cassette	Clamping Screw	TORX PLUS® Wrench
LAK220...	6.23T25P	T25PQ

Cassette

LAK220

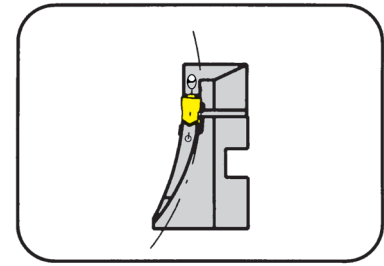

Outer groove \varnothing
Depth of groove up to
Width of groove

60 - 1000 mm
25 mm
6 mm

for Indexable insert

Type 229
S229

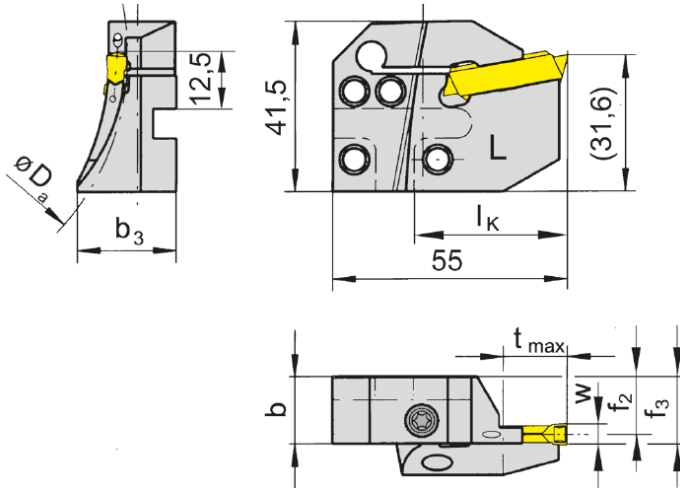

L = left hand version

Part number	$D_{a \min}$	$D_{a \max}$	t_{\max}	b	b_3	f_2	f_3	w_{\max}	l_K
LAK220.6075.06.IK	60	75	10	15.7	23.0	13.4	$f_2+w/2$	6	36
LAK220.7595.06.IK	75	95	17	15.7	23.0	13.4	$f_2+w/2$	6	36
LAK220.9513.06.IK	95	130	25	15.7	23.0	13.4	$f_2+w/2$	6	36
LAK220.1318.06.IK	130	180	25	15.7	21.2	13.4	$f_2+w/2$	6	36
LAK220.1830.06.IK	180	300	25	15.7	19.0	13.4	$f_2+w/2$	6	36
LAK220.3000.06.IK	300	1000	25	15.7	16.8	13.4	$f_2+w/2$	6	36

For basic toolholder L...K1 and R...K2

Dimensions in mm

Further sizes upon request

Ordering note:

The fastening screw is combined with the basic toolholder - no separate order required.

For torque specification of the screw, please see Technical Instructions.

Spare Parts

Cassette	Clamping Screw	TORX PLUS® Wrench
LAK220...	6.23T25P	T25PQ

Cassette

RAK220

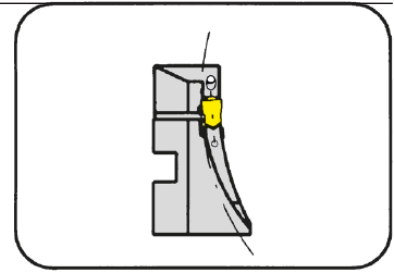

Outer groove Ø
Depth of groove up to
Width of groove

60 - 1000 mm
25 mm
4 - 5 mm

for Indexable insert

Type 229
S229

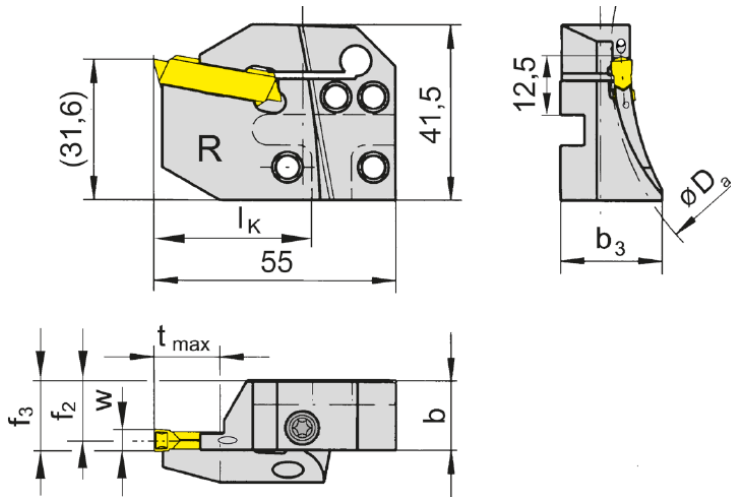

R = right hand version

Part number	D _{a min}	D _{a max}	t _{max}	b	b ₃	f ₂	f ₃	w _{max}	l _k
RAK220.6575.04.IK	65	75	10	15.7	23.0	14.4	f ₂ +w/2	4	36
RAK220.7595.04.IK	75	95	15	15.7	23.0	14.4	f ₂ +w/2	4	36
RAK220.9513.04.IK	95	130	25	15.7	21.2	14.4	f ₂ +w/2	4	36
RAK220.1318.04.IK	130	180	25	15.7	21.2	14.4	f ₂ +w/2	4	36
RAK220.1830.04.IK	180	300	25	15.7	19.0	14.4	f ₂ +w/2	4	36
RAK220.3000.04.IK	300	1000	25	15.7	16.8	14.4	f ₂ +w/2	4	36
RAK220.6075.05.IK	60	75	10	15.7	23.0	13.9	f ₂ +w/2	5	36
RAK220.7595.05.IK	75	95	15	15.7	23.0	13.9	f ₂ +w/2	5	36
RAK220.9513.05.IK	95	130	25	15.7	23.0	13.9	f ₂ +w/2	5	36
RAK220.1318.05.IK	130	180	25	15.7	21.2	13.9	f ₂ +w/2	5	36
RAK220.1830.05.IK	180	300	25	15.7	19.0	13.9	f ₂ +w/2	5	36
RAK220.3000.05.IK	300	1000	25	15.7	16.8	13.9	f ₂ +w/2	5	36

For basic toolholder R...K1 and L...K2

Dimensions in mm

Further sizes upon request

Ordering note:

The fastening screw is combined with the basic toolholder - no separate order required.

For torque specification of the screw, please see Technical Instructions.

Spare Parts

Cassette	Clamping Screw	TORX PLUS® Wrench
RAK220...	6.23T25P	T25PQ

Face Grooving



Cassette

RAK220

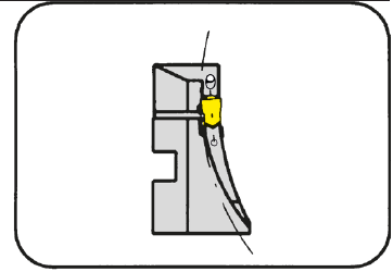

Outer groove Ø
Depth of groove up to
Width of groove

60 - 1000 mm
25 mm
6 mm

for Indexable insert

Type 229
S229

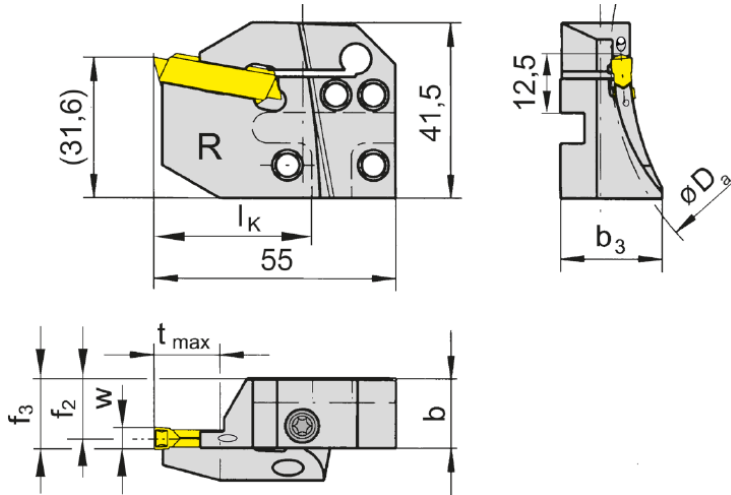

R = right hand version

Part number	D _{a min}	D _{a max}	t _{max}	b	b ₃	f ₂	f ₃	w _{max}	l _k
RAK220.6075.06.IK	60	75	10	15.7	23.0	13.4	f ₂ +w/2	6	36
RAK220.7595.06.IK	75	95	17	15.7	23.0	13.4	f ₂ +w/2	6	36
RAK220.9513.06.IK	95	130	25	15.7	23.0	13.4	f ₂ +w/2	6	36
RAK220.1318.06.IK	130	180	25	15.7	21.2	13.4	f ₂ +w/2	6	36
RAK220.1830.06.IK	180	300	25	15.7	19.0	13.4	f ₂ +w/2	6	36
RAK220.3000.06.IK	300	1000	25	15.7	16.8	13.4	f ₂ +w/2	6	36

For basic toolholder R...K1 and L...K2

Dimensions in mm

Further sizes upon request

Ordering note:

The fastening screw is combined with the basic toolholder - no separate order required.

For torque specification of the screw, please see Technical Instructions.

Spare Parts

Cassette	Clamping Screw	TORX PLUS® Wrench
RAK220...	6.23T25P	T25PQ



Indexable insert

S229

with chip former

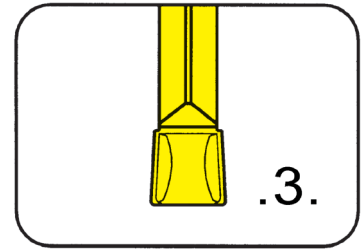

Depth of groove up to
Width of groove

.984"
.157 - .236"

precision sintered

for Cassette

Type R/LAK220
R/LIK220

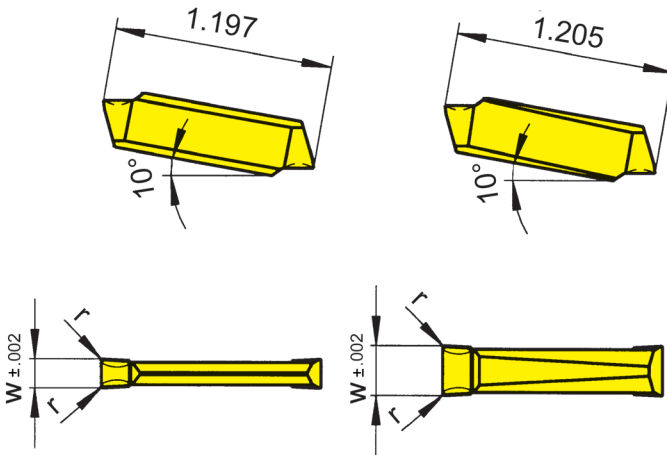

Width = .157" - .197"

Width = .236"

Indexability length ± .002"

Part number	w	r	Size	Carbide grades													
				MG12	P20	AL96	AS62	AS66	H54	TA45	TC92	TF42	TF45	TI22	TI25	TN32	TN35
S229.0400.32	.157	.008	04	x	x	▲	▲	▲	▲	▲	x	Δ	▲	x	▲	▲	▲
S229.0400.34	.157	.016	04	x	x	▲	▲	▲	▲	▲		Δ	▲	x	▲	▲	▲
S229.0500.34	.197	.016	04	x	x	▲	▲	▲	x	x	Δ	▲	▲	▲	▲	▲	▲
S229.0500.36	.197	.024	04		x				x		x		x	x	x	x	x
S229.0600.34	.236	.016	05	x	x	▲	▲	▲	x	x	Δ	▲	▲	▲	▲	▲	▲
S229.0600.38	.236	.031	05			▲	▲	▲			Δ		x				
				P	○	●	●	●	●	●	●	●	●	●	●	●	●
				M	-	-	-	-	○	●	●	-	-	-	●	-	●
				K	-	-	●	-	●	-	●	-	-	-	●	-	●
				N	-	-	●	-	●	-	●	-	-	-	●	-	●
				S	-	-	-	-	○	-	●	-	-	●	-	●	●
				H	-	-	-	-	-	-	-	-	-	-	-	-	-

Dimensions in inch

Carbide grades

Indexable inserts can be used in right and left hand cassettes L/RAK220 and L/RIK220.

Indexable insert

S229

with chip forming

Depth of groove up to
Width of groove

.984"
.157 - .236"

precision sintered

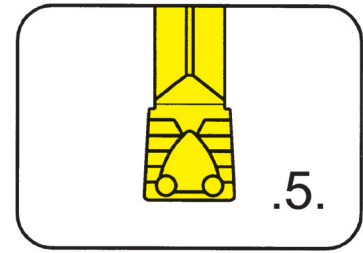

for Cassette

Type R/LAK220
R/LIK220

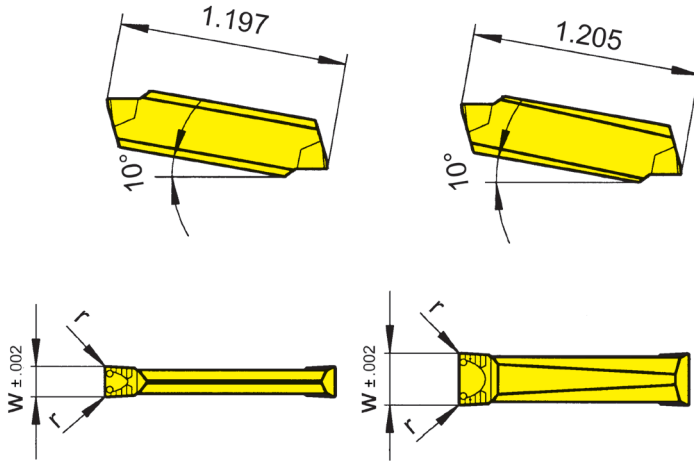

Width = .118" - .197"

Width = .236"

Indexability length ± .002

Part number	w	r	Size	Carbide grades									
				P20	AL96	AS62	TC92	TF45	T122	T125	TN32	TN35	
S229.0400.52	.157	.008	04	x	x	▲	△	▲	▲	▲	▲	▲	▲
S229.0400.54	.157	.016	04		x	▲		▲	▲	▲	▲	▲	▲
S229.0500.54	.197	.016	04	x	x	▲	△	▲	▲	▲	▲	▲	▲
S229.0600.54	.236	.016	05	x	▲	▲	△	▲		▲	▲	▲	▲
S229.0600.56	.236	.024	05		x		x			x	x	x	x
S229.0500.56	.197	.024	06				x			x	x	x	x
▲ on stock △ 4 weeks x upon request				P	●	●	●	●	●	●	●	●	●
● recommended				M	-	-	-	-	-	●	-	●	●
○ alternative recommendation				K	-	●	-	-	●	-	●	-	●
- not suitable				N	-	●	-	-	●	-	●	-	●
■ uncoated grades				S	-	-	-	-	●	-	●	-	●
■ coated grades				H	-	-	-	-	-	-	-	-	-
■ brazed/Cermet													

Dimensions in inch

Carbide grades

Indexable inserts can be used in right and left hand cassettes L/RAK220 and L/RIK220.



Indexable insert

S229

with chip forming

Depth of groove up to
Width of groove

.984"
.157 - .236"

precision sintered

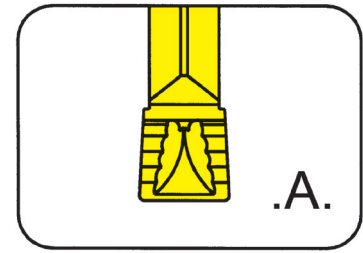

for Cassette

Type R/LAK220
R/LIK220

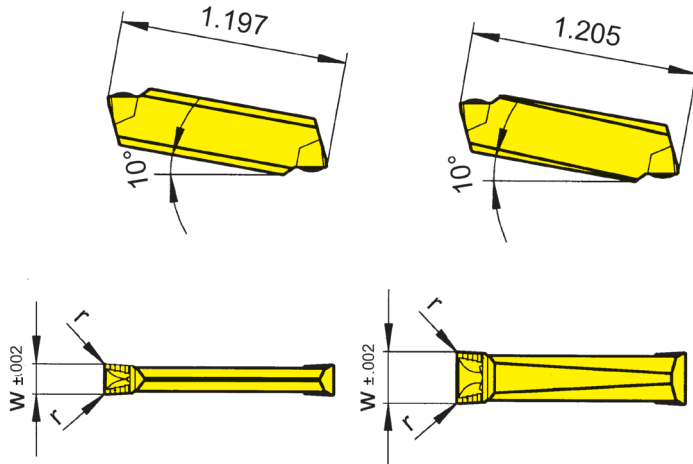

Width = .118" - .197"

Width = .236"

Indexability length $\pm .002''$

Part number	w	r	Size	P20	AL96	AS62	TC92	TF42	TF45	TI22	TI25	TN32	TN35
S229.0400.A2	.157	.008	04	x	x	▲	△		▲	▲	▲	▲	▲
S229.0400.A4	.157	.016	04		x	▲	△	▲	x	▲	▲	▲	▲
S229.0500.A4	.197	.016	04			▲	△		▲	▲	x	▲	▲
S229.0600.A4	.236	.016	05	x	▲	▲	△	▲	▲	▲	▲	▲	▲
				P	●	●	●	●	●	●	●	●	●
				M	-	-	-	-	-	-	●	-	●
				K	-	●	-	-	●	-	●	-	●
				N	-	●	-	-	●	-	●	-	●
				S	-	-	-	-	●	-	●	-	●
				H	-	-	-	-	-	-	-	-	-

▲ on stock △ 4 weeks x upon request
● recommended
○ alternative recommendation
- not suitable
■ uncoated grades
■ coated grades
■ brazed/Cermet

Dimensions in inch

Carbide grades

Indexable inserts can be used in right and left hand cassettes L/RAK220 and L/RIK220.

Indexable insert

S229

with chip forming

Depth of groove up to
Width of groove

.984"
.157 - .236"

precision sintered

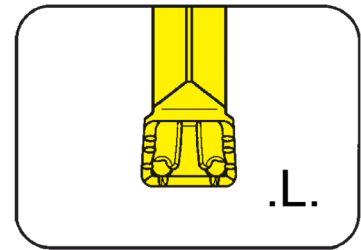

for Cassette

Type R/LAK220
R/LIK220

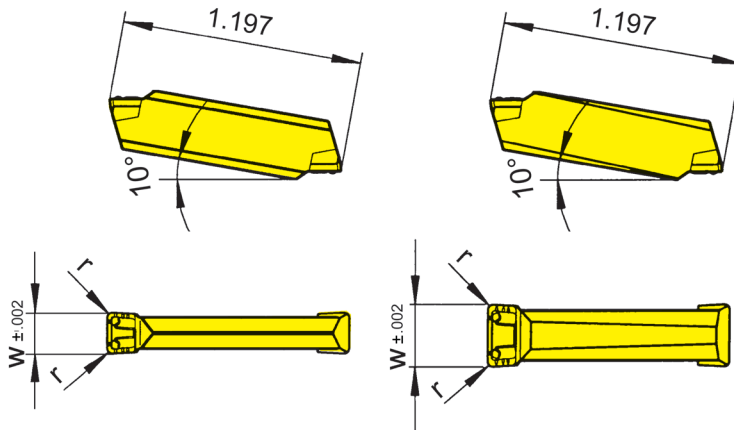

Width = .118" - .197"

Width = .236"

Indexability length ± .002"

Part number	w	r	Size	Carbide grades				
				AL96	AS62	AS66	TF42	TI22
S229.0400.L4	.157	.016	04	▲	▲	▲	▲	▲
S229.0500.L4	.197	.016	04	▲	▲	▲	▲	▲
S229.0500.L6	.197	.024	04	▲	▲	▲	▲	▲
S229.0600.L4	.236	.016	05	▲	▲	▲	▲	▲
S229.0600.L6	.236	.024	05	▲	▲	▲	▲	▲

▲ on stock Δ 4 weeks x upon request

● recommended

○ alternative recommendation

- not suitable

□ uncoated grades

■ coated grades

■ brazed/Cermet

Dimensions in inch

P	●	●	●	●	●
M	-	-	○	-	-
K	●	-	●	-	-
N	●	-	●	-	-
S	-	-	○	-	-
H	-	-	-	-	-

Carbide grades

Indexable inserts can be used in right and left hand cassettes L/RAK220 and L/RIK220.

Insert

229

Depth of groove up to .157"
Width of groove .118 - .157"

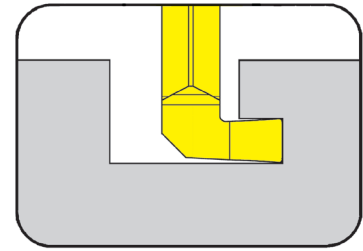

for Toolholder

- Type 210
218
226
219
213
214
226
257

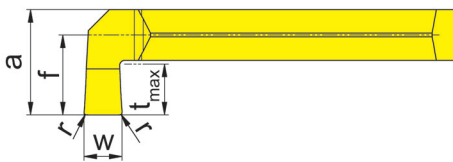
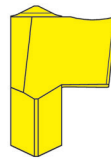
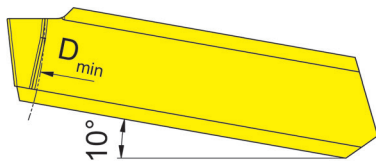

R = right hand version shown

L = left hand version

Part number	w	r	t _{max}	a	f	D _{min}	Size	AS65
R/L229.3040.HA50.12	.118	.008	.157	.327	.248	1.969	04	ΔΔ
R/L229.4040.HA50.12	.157	.008	.157	.327	.248	1.969	04	ΔΔ

▲ on stock Δ 4 weeks x upon request

- recommended
- alternative recommendation
- not suitable

- uncoated grades
- coated grades
- brazed/Cermet

Dimensions in inch

P	●
M	○
K	○
N	-
S	-
H	-

Carbide grades

State R or L version



Toolholder

221/228

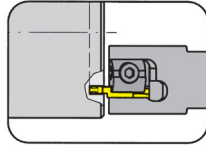

Page
T110-T113

Indexable insert

231

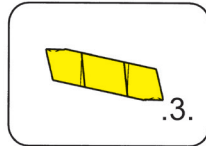

Page
T114

T

231



T

Toolholder with Inserts

Width of groove .118 - .394"

Toolholder

U221

from outer groove \varnothing
Depth of groove up to
Clamping range

1.575"
.315"
.118 - .394"

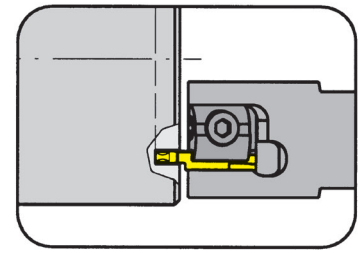

for Indexable insert

Type 231
N231

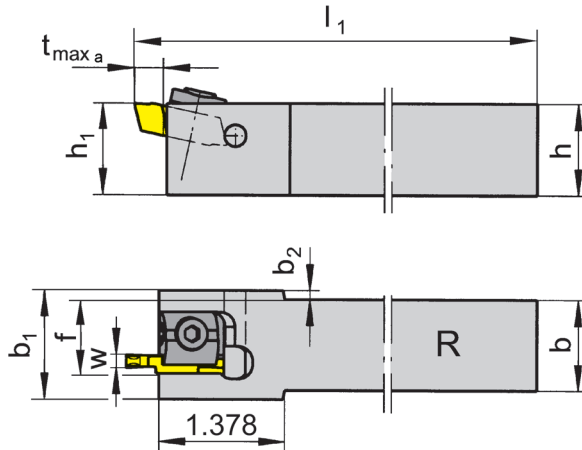

R = right hand version shown

L = left hand version

Part number	h	b	l_1	h_1	b_1	f	$t_{max a}$	b_2	Size	Clamping range
R/LU221.0750.04	.750	.750	5.118	.750	1.102	.705	.315	.157	04	.118 - .157
R/LU221.1000.04	1.000	1.000	6.004	1.000	1.181	.803	.315	.098	04	.118 - .157
R/LU221.0750.05	.750	.750	5.118	.750	1.181	.744	.315	.197	05	.157 - .236
R/LU221.1000.05	1.000	1.000	6.004	1.000	1.181	.843	.315	.098	05	.157 - .236
R/LU221.0750.07	.750	.750	5.118	.750	1.260	.783	.315	.236	07	.236 - .315
R/LU221.1000.07	1.000	1.000	6.004	1.000	1.260	.882	.315	.138	07	.236 - .315
R/LU221.0750.09	.750	.750	5.118	.750	1.339	.823	.315	.276	09	.315 - .394
R/LU221.1000.09	1.000	1.000	6.004	1.000	1.339	.921	.315	.177	09	.315 - .394

State R or L version

w see indexable inserts

Dimensions in inch

Further sizes upon request

This toolholder can be used from $D_a = 1.181''$ up to ∞ depending on grooving depth.

For torque specification of the screw, please see Technical Instructions.

Spare Parts

Toolholder	Stop Pin	Clamping element	TORX PLUS® Wrench
R/LU221...	3.6.28	01.60.12	T20PQ

Toolholder

221

from outer groove \varnothing
Depth of groove up to
Clamping range

40 mm
8 mm
3 - 10 mm

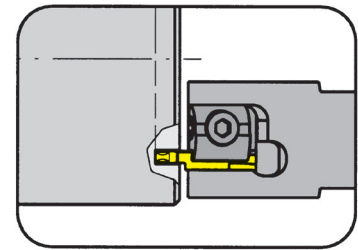

for Indexable insert

Type 231
N231

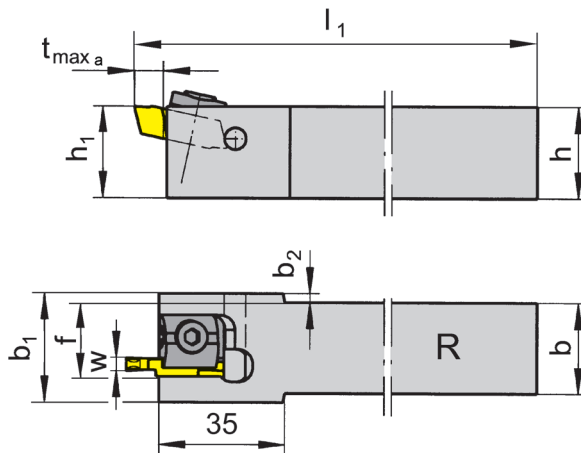

R = right hand version shown

L = left hand version

Part number	h	b	l_1	h_1	b_1	f	$t_{max a}$	b_2	$D_{a min}$	Size	Clamping range
R/L221.2020.04	20	20	125	20	28	17.9	8	4.0	40	04	3.0 - 4.0
R/L221.2525.04	25	25	150	25	28	20.4	8	1.5	40	04	3.0 - 4.0
R/L221.2020.05	20	20	125	20	30	18.9	8	5.0	40	05	4.1 - 6.0
R/L221.2525.05	25	25	150	25	30	21.4	8	2.5	40	05	4.1 - 6.0
R/L221.2020.07	20	20	125	20	32	19.9	8	6.0	40	07	6.1 - 8.0
R/L221.2525.07	25	25	150	25	32	22.4	8	3.5	40	07	6.1 - 8.0
R/L221.2020.09	20	20	125	20	34	20.9	8	7.0	40	09	8.1 - 10.0
R/L221.2525.09	25	25	150	25	34	23.4	8	4.5	40	09	8.1 - 10.0

State R or L version

w see indexable inserts

Dimensions in mm

Further sizes upon request

This toolholder can be used from $D_a = 30$ mm up to ∞ depending on grooving depth.

For torque specification of the screw, please see Technical Instructions.

Spare Parts

Toolholder	Stop Pin	Clamping element	TORX PLUS® Wrench
R/L221...	3.6.28	01.60.12	T20PQ

Toolholder

U228

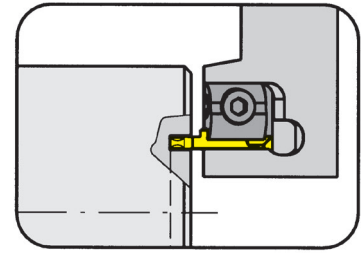

from outer groove \varnothing 1.575"
 Depth of groove up to .315"
 Clamping range .394"

for Indexable insert

Type 231
 N231

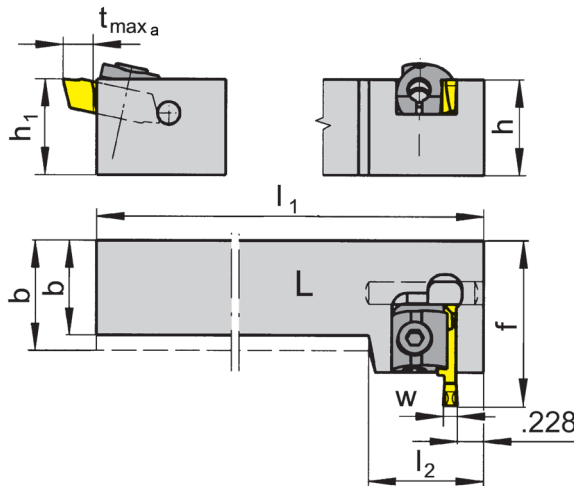

L = left hand version shown

R = right hand version

Part number	h	b	h ₁	f	t _{max a}	l ₁	l ₂	Size	Clamping range
R/LU228.0750.04	.750	.750	.750	1.516	.315	5.118	1.398	04	.118 - .157
R/LU228.1000.04	1.000	1.000	1.000	1.516	.315	6.004	1.398	04	.118 - .157
R/LU228.0750.05	.750	.750	.750	1.516	.315	5.118	1.398	05	.157 - .236
R/LU228.1000.05	1.000	1.000	1.000	1.516	.315	6.004	1.398	05	.157 - .236
R/LU228.0750.07	.750	.750	.750	1.516	.315	5.118	1.398	07	.236 - .315
R/LU228.1000.07	1.000	1.000	1.000	1.516	.315	6.004	1.398	07	.236 - .315
R/LU228.0750.09	.750	.750	.750	1.516	.315	5.118	1.398	09	.315 - .394
R/LU228.1000.09	1.000	1.000	1.000	1.516	.315	6.004	1.398	09	.315 - .394

State R or L version

w see indexable inserts

Dimensions in inch

Further sizes upon request

This toolholder can be used from Da = 1.181" up to ∞ depending on grooving depth.

For torque specification of the screw, please see Technical Instructions.

Spare Parts

Toolholder	Stop Pin	Clamping element	TORX PLUS® Wrench
R/LU228...	3.6.28	01.60.12	T20PQ

Toolholder

228

from outer groove \varnothing
Depth of groove up to
Clamping range

40 mm
8 mm
3 - 10 mm

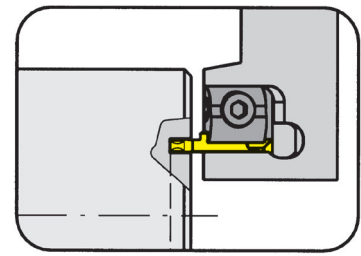

for Indexable insert

Type 231
N231

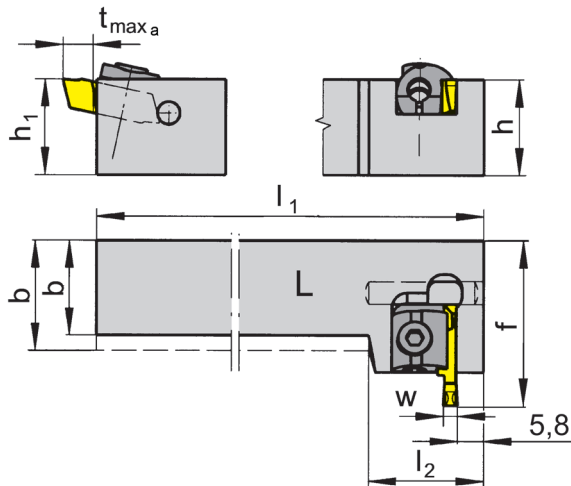

L = left hand version shown

R = right hand version

Part number	h	b	h ₁	f	t _{max a}	D _{a min}	l ₁	l ₂	Size	Clamping range
R/L228.2020.04	20	20	20	38.5	8	40	125	35.5	04	3.0 - 4.0
R/L228.2525.04	25	25	25	38.5	8	40	150	35.5	04	3.0 - 4.0
R/L228.2020.05	20	20	20	38.5	8	40	125	35.5	05	4.1 - 6.0
R/L228.2525.05	25	25	25	38.5	8	40	150	35.5	05	4.1 - 6.0
R/L228.2020.07	20	20	20	38.5	8	40	125	35.5	07	6.1 - 8.0
R/L228.2525.07	25	25	25	38.5	8	40	150	35.5	07	6.1 - 8.0
R/L228.2020.09	20	20	20	38.5	8	40	125	35.5	09	8.1 - 10.0
R/L228.2525.09	25	25	25	38.5	8	40	150	35.5	09	8.1 - 10.0

State R or L version

w see indexable inserts

Dimensions in mm

Further sizes upon request

This toolholder can be used from D_a = 30 mm up to ∞ depending on grooving depth.

For torque specification of the screw, please see Technical Instructions.

Spare Parts

Toolholder	Stop Pin	Clamping element	TORX PLUS® Wrench
R/L228...	3.6.28	01.60.12	T20PQ

Indexable insert

231

with chip former

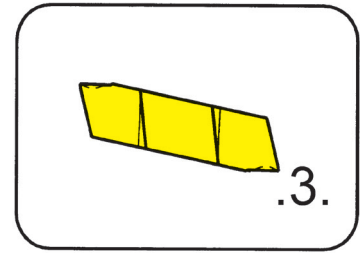

from outer groove \varnothing 1.575"
 Depth of groove up to .315"
 Width of groove .118 - .394"

for Toolholder

Type 221
 U221
 228
 U228

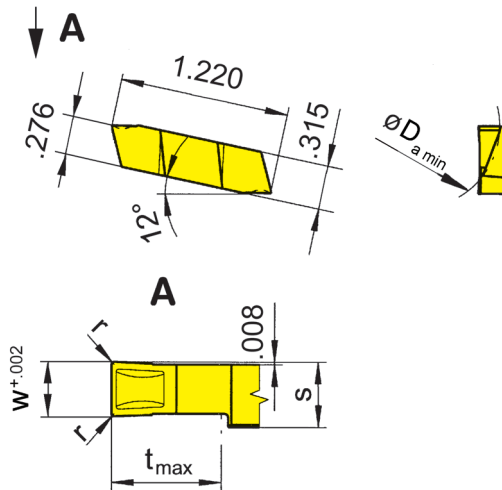

Indexability length $\pm .001''$

Part number	w	r	t _{max}	s	D _{a min}	Size	TN35
R/L231.4030.32	.118	.008	.315	.150	1.575	04	▲▲
R/L231.4040.32	.157	.008	.315	.150	1.575	04	▲▲
R/L231.4050.34	.197	.016	.315	.228	1.575	05	▲▲
N231.4060.34	.236	.016	.315	.228	1.575	05	▲
N231.4070.36	.276	.024	.315	.307	1.575	07	△
N231.4080.36	.315	.024	.315	.307	1.575	07	▲
N231.4090.38	.354	.031	.315	.386	1.575	09	▲
N231.4100.38	.394	.031	.315	.386	1.575	09	▲

▲ on stock Δ 4 weeks x upon request
 ● recommended
 ○ alternative recommendation
 - not suitable
 □ uncoated grades
 ■ coated grades
 ■ brazed/Cermet

P	•
M	•
K	•
N	•
S	•
H	-

Carbide grades

Dimensions in inch

State R, L or N version

Outer- \varnothing of groove < 1.575" upon request.



Toolholder

360/369

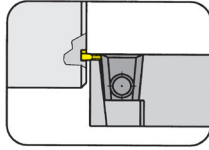

Page
T118-T119

Indexable insert

312

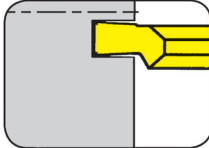

Page
T120

T

312

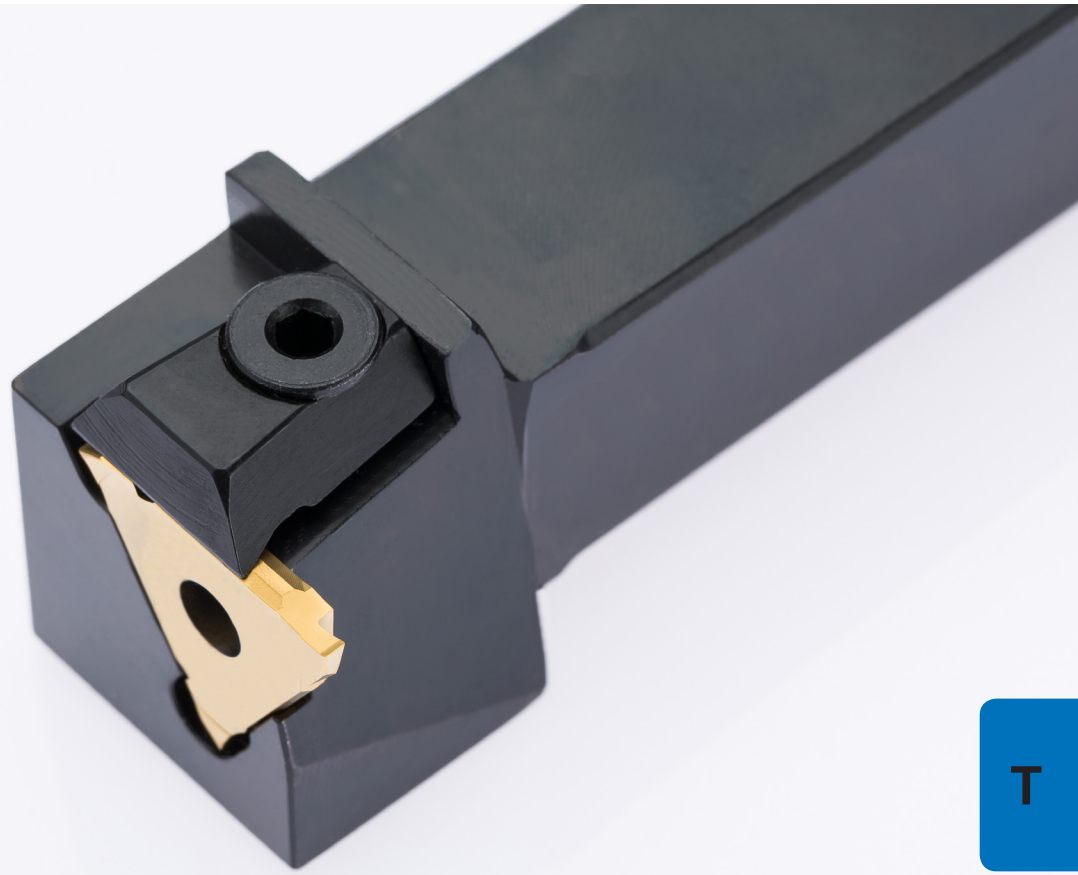

Toolholder with Inserts

Width of groove .059 - .118"

Toolholder

360

from outer groove \varnothing
Depth of groove up to
Clamping range

20 mm
6 mm
1.9 - 3.9 mm

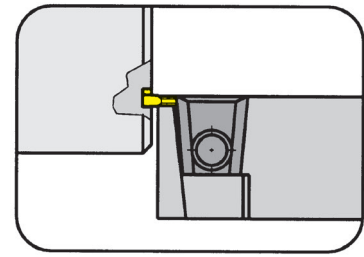

for Indexable insert

Type 312
S312

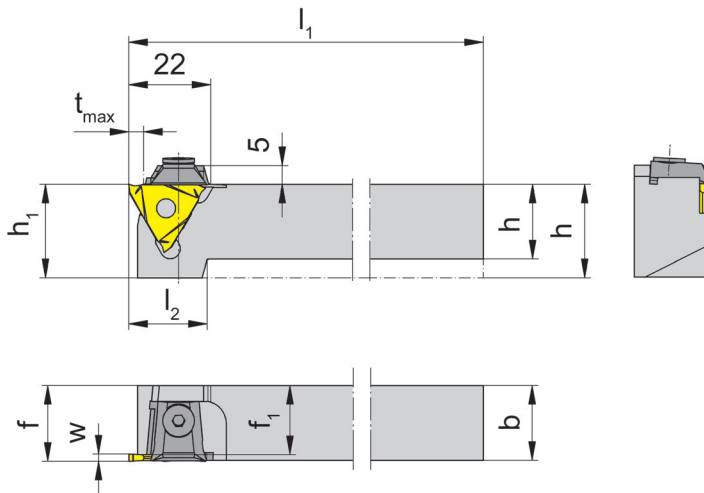

R = right hand version shown

L = left hand version

Part number	h	b	l ₁	l ₂	h ₁	f ₁	f	t _{max}	Size	Clamping range
R/L360.1212.02	12	12	100	24	25	9.5	f ₁ +w-a ₁	6	02	1.9 - 2.9
R/L360.1616.02	16	16	125	22	25	13.5	f ₁ +w-a ₁	6	02	1.9 - 2.9
R/L360.2020.02	20	20	125	21	25	17.5	f ₁ +w-a ₁	6	02	1.9 - 2.9
R/L360.2525.02	25	25	150	-	25	22.5	f ₁ +w-a ₁	6	02	1.9 - 2.9
R/L360.3232.02	32	32	170	-	32	29.5	f ₁ +w-a ₁	6	02	1.9 - 2.9
R/L360.1212.03	12	12	100	24	25	8.5	f ₁ +w-a ₁	6	03	2.9 - 3.9
R/L360.1616.03	16	16	125	22	25	12.5	f ₁ +w-a ₁	6	03	2.9 - 3.9
R/L360.2020.03	20	20	125	21	25	16.5	f ₁ +w-a ₁	6	03	2.9 - 3.9
R/L360.2525.03	25	25	150	-	25	21.5	f ₁ +w-a ₁	6	03	2.9 - 3.9
R/L360.3232.03	32	32	170	-	32	28.5	f ₁ +w-a ₁	6	03	2.9 - 3.9

State R or L version

w, a₁ see indexable inserts

Dimensions in mm

For torque specification of the screw, please see Technical Instructions.

Spare Parts

Toolholder	Allen wrench	Clamping element
R/L360...1	SW3,0 DIN911	11.3
R/L360...	SW3,0 DIN911	16.4

Toolholder

369

from outer groove \varnothing
Depth of groove up to
Clamping range

20 mm
6 mm
1.9 - 3.9 mm

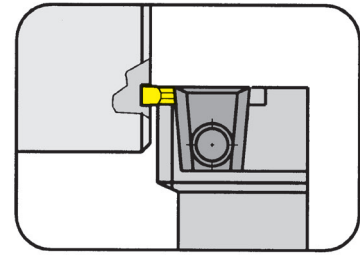

for Indexable insert

Type 312
S312

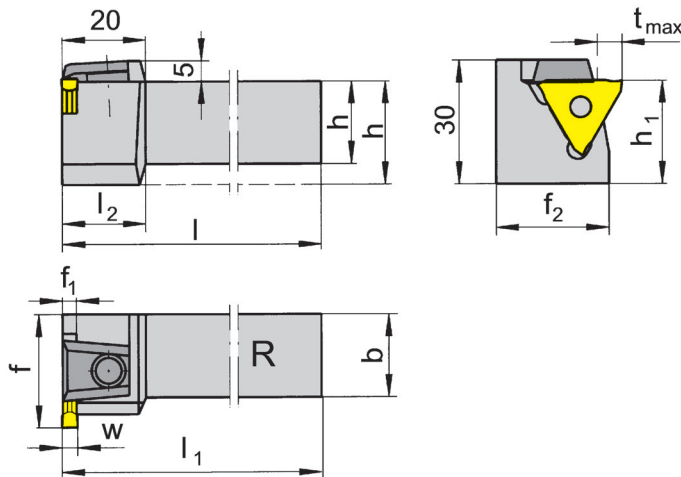

R = right hand version shown

L = left hand version

Part number	h	b	l	l_1	l_2	h_1	f	t_{max}	f_1	f_2	Size	Clamping range
R/L369.2020.02	20	20	125	$l-f_1+w-a_1$	20	25	27	6	2.5	23.5	02	1.9 - 2.9
R/L369.2525.02	25	25	150	$l-f_1+w-a_1$	-	25	32	6	2.5	28.5	02	1.9 - 2.9
R/L369.2020.03	20	20	125	$l-f_1+w-a_1$	20	25	27	6	3.5	23.5	03	2.9 - 3.9
R/L369.2525.03	25	25	150	$l-f_1+w-a_1$	-	25	32	6	3.5	28.5	03	2.9 - 3.9

State R or L version

w, a_1 see indexable inserts

Dimensions in mm

Further sizes upon request

For torque specification of the screw, please see Technical Instructions.

Spare Parts

Toolholder	Allen wrench	Clamping element
R/L369...	SW3,0 DIN911	16.4



Indexable insert

312

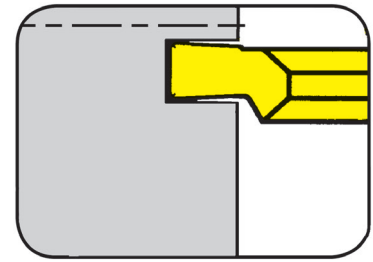

from outer groove \emptyset .787"
 Depth of groove up to .138"
 Width of groove .059 - .197"

for Toolholder

Type 360
 369

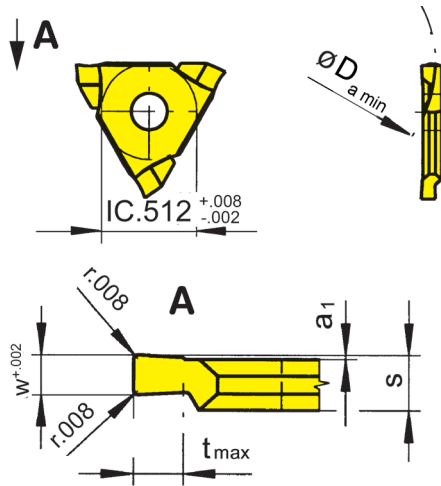

R = right hand version shown

L = left hand version

Indexability length
 $\pm .0008''$

Part number	w	t _{max}	a ₁	s	D _{a min}	Size	EG55	TN35
R/L312.2015.02	.059	.079	.008	.106	.787	02	▲/▲	▲/▲
R/L312.3030.02	.118	.118	.008	.146	1.181	03	▲/▲	▲/▲
R/L312.3040.02	.157	.138	.008	.169	1.181	04	△/△	
R/L312.3050.02	.197	.138	.008	.209	1.181	05	△/△	

▲ on stock Δ 4 weeks x upon request

- recommended
- alternative recommendation
- not suitable

- uncoated grades
- coated grades
- brazed/Cermet

Dimensions in inch

State R or L version

Note for toolholder type 360

Use right hand inserts in left hand toolholders and left hand inserts in right hand toolholders

Note for toolholder type 369

Use right hand inserts in right hand toolholders and left hand inserts in left hand toolholders

	EG55	TN35
P	●	●
M	○	●
K	○	●
N	-	●
S	-	●
H	-	-

Carbide grades



Toolholder

356/357

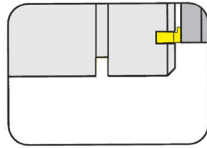

Page
T124-T125

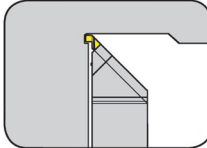

Page
T126

Indexable insert

A315

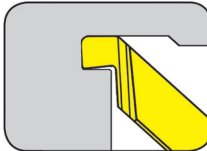

Page
T127

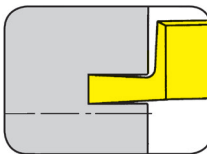

Page
T128-T129

T

A315

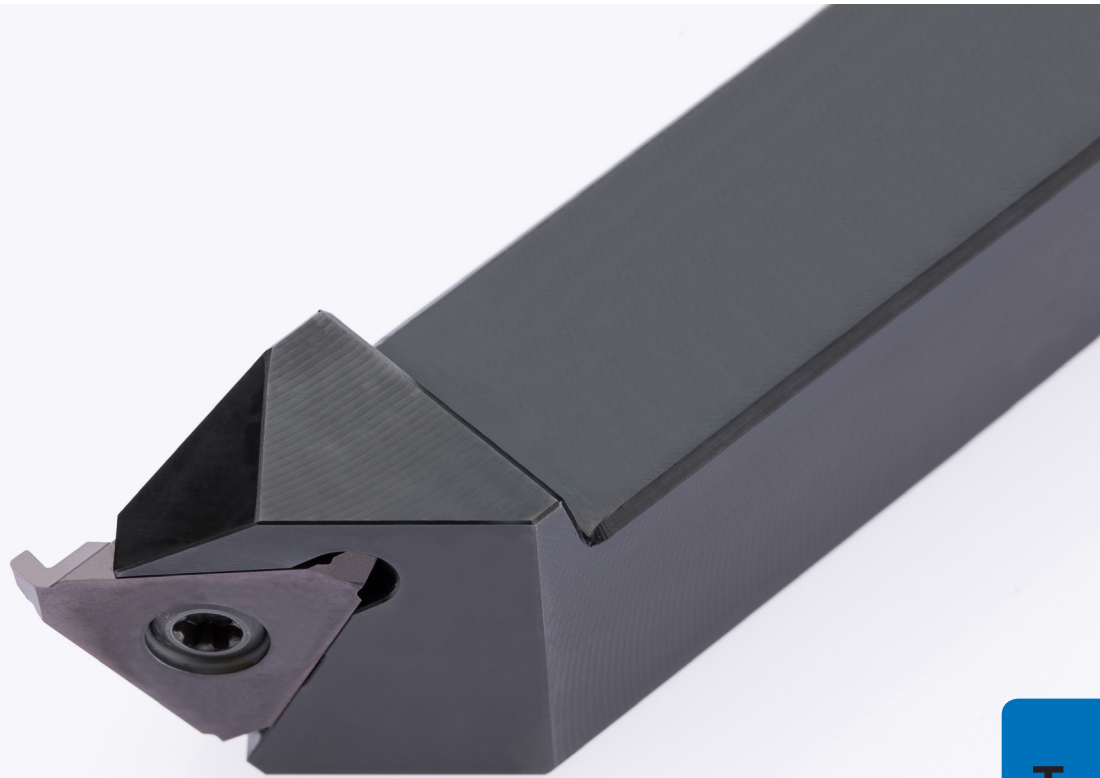

T

Toolholder with Inserts

Width of groove .059 - .118"

Toolholder

356

Depth of groove up to
Width of groove

5 mm
0.5 - 7.3 mm

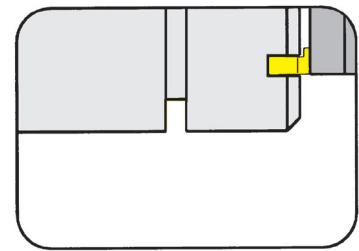

for Indexable insert

Type LA315
RA315

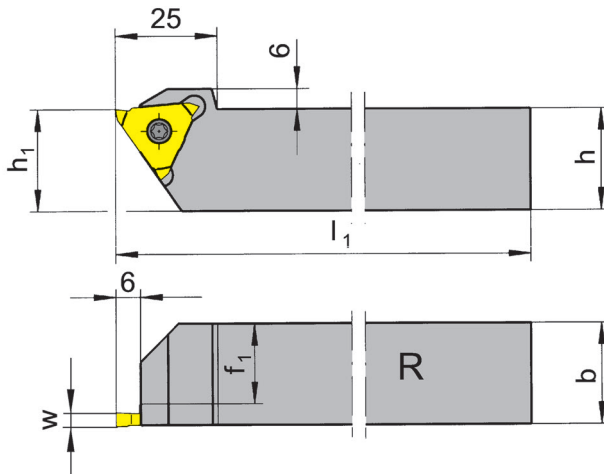

R = right hand version shown

L = left hand version

Part number	h	b	l ₁	h ₁	f ₁	Size
R/L356.1616.03	16	16	125	20	13.0	03
R/L356.2020.03	20	20	125	20	17.0	03
R/L356.2525.03	25	25	150	25	22.0	03
R/L356.3232.03	32	32	170	32	29.0	03
R/L356.1616.05	16	16	125	20	10.8	05
R/L356.2020.05	20	20	125	20	14.8	05
R/L356.2525.05	25	25	150	25	19.8	05
R/L356.3232.05	32	32	170	32	26.8	05
R/L356.2525.07	25	25	150	25	18.0	07
R/L356.2020.07	20	20	125	20	13.0	07
R/L356.3232.07	32	32	170	32	25.0	07

State R or L version

w see indexable inserts

Dimensions in mm

Further sizes upon request

For torque specification of the screw, please see Technical Instructions.

Spare Parts

Toolholder	Clamping Screw	TORX PLUS® Wrench
R/L356...03/05	5.12T20P	T20PQ
R/L356...07	5.15T20P	T20PQ

Toolholder

357

Depth of groove up to
Width of groove

5 mm
0.5 - 5.3 mm

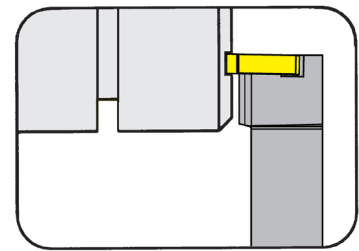

for Indexable insert

Type LA315
RA315

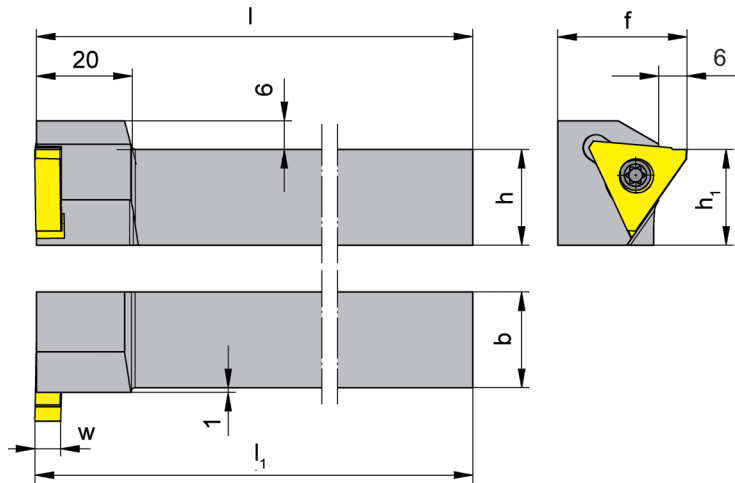

R = right hand version shown

L = left hand version

Part number	h	b	l ₁	l	h ₁	f	Size
R/L357.2020.05	20	20	125.3	125	20	27	05
R/L357.2525.05	25	25	150.3	150	25	32	05

State R or L version

w see indexable inserts

Dimensions in mm

Further sizes upon request

Ordering note:

Use right hand inserts in left hand toolholders and left hand inserts in right hand toolholders

For torque specification of the screw, please see Technical Instructions.

Spare Parts

Toolholder	Clamping Screw	TORX PLUS® Wrench
R/L357...	5.12T20P	T20PQ

Grooving Corner Reliefs (external)



Toolholder

356

Corner reliefs (45°)

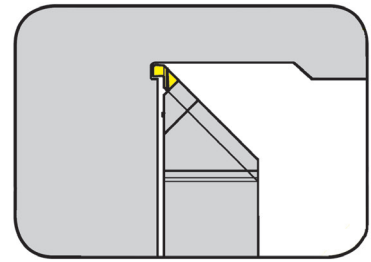

for Indexable insert

Type RA315
LA315

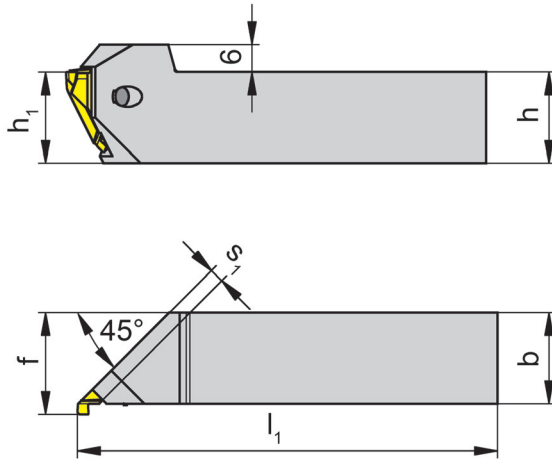

R = right hand version shown

L = left hand version

Part number	h	b	l ₁	h ₁	f	s ₁	Size
R/L356.2020.45.03	20	20	125	20	22.3	3.25	03
R/L356.2525.45.03	25	25	150	25	27.3	3.25	03

State R or L version

Dimensions in mm

Ordering note:

Use right hand inserts in left hand toolholders and left hand inserts in right hand toolholders

For torque specification of the screw, please see Technical Instructions.

Spare Parts

Toolholder	Clamping Screw	TORX PLUS® Wrench
R/L356...	5F.08T20P	T20PQ



Indexable insert

R/LA315

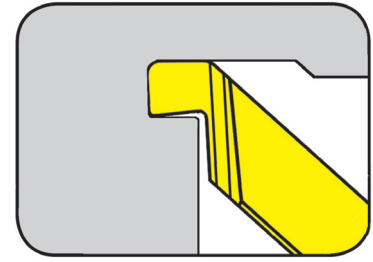

from outer groove \varnothing .315"
 Depth of groove up to .079"
 Width of groove .059 - .094"

for Toolholder

Type R/L356...45.03

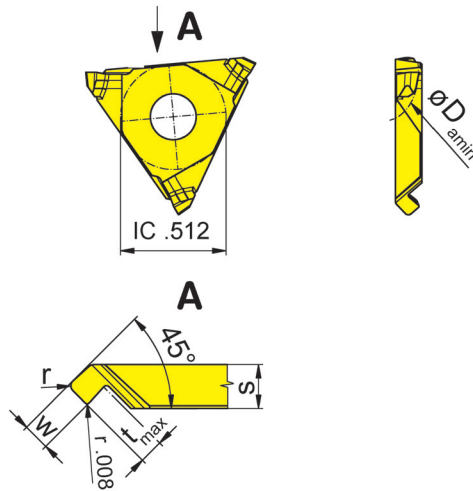

L = left hand version shown

R = right hand version

Indexability length
 $\pm .0008''$



Part number	w	r	t _{max}	D _{a min}	s	Size	TH35	TN35
LA315.0815.45.04R	.059	.016	.063	.315	.128	03	▲	▲
RA315.0815.45.04L	.059	.016	.063	.315	.128	03	▲	▲
LA315.1220.45.05R	.079	.020	.071	.472	.128	03	▲	▲
RA315.1220.45.05L	.079	.020	.071	.472	.128	03	▲	▲
LA315.2024.45.06R	.094	.024	.079	.787	.128	03	▲	▲
RA315.2024.45.06L	.094	.024	.079	.787	.128	03	▲	▲

▲ on stock Δ 4 weeks x upon request

- recommended
- alternative recommendation
- not suitable

- uncoated grades
- coated grades
- brazed/Cermet

Dimensions in inch

	TH35	TN35
P	●	●
M	●	●
K	●	●
N	●	●
S	●	●
H	-	-

Carbide grades

State R or L version

Note for toolholder type 356...45..

Use right hand inserts in left hand toolholders and left hand inserts in right hand toolholders

The undercut must be placed BEFORE the axial machining!

Indexable insert

R/LA315

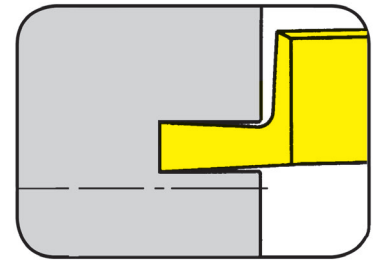

from outer groove \varnothing .787"
 Depth of groove up to .118"
 Width of groove .059 - .118"

for Toolholder

Type 356...03-07
 357

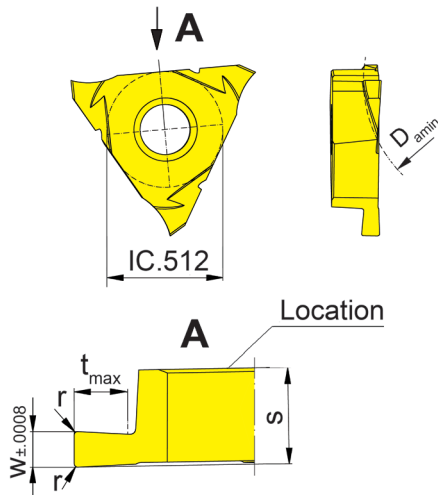

R = right hand version shown

L = left hand version

Part number	w	r	t _{max}	D _{a min}	s	Size	TH35	TN35
LA315.2015.02R	.059	.008	.079	.787	.213	05	Δ/▲	
RA315.2015.02L	.059	.008	.079	.787	.213	05	▲	
LA315.3020.02R	.079	.008	.118	1.181	.213	05	Δ/▲	x/x
RA315.3020.02L	.079	.008	.118	1.181	.213	05	▲	
LA315.3030.02R	.118	.008	.118	1.181	.213	05	Δ/▲	
RA315.3030.02L	.118	.008	.118	1.181	.213	05	▲	

▲ on stock Δ 4 weeks x upon request

● recommended
 o alternative recommendation
 - not suitable

□ uncoated grades
 ■ coated grades
 ■ brazed/Cermet

Dimensions in inch

	TH35	TN35
P	●	●
M	●	●
K	●	●
N	●	●
S	●	●
H	-	-

Carbide grades

Indexable insert

RA315

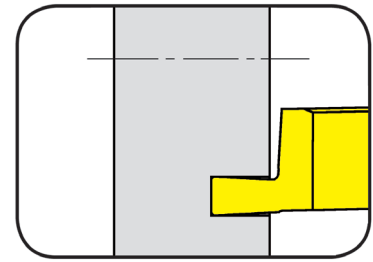

from outer groove \varnothing .787"
 Depth of groove up to .118"
 Width of groove .059 - .118"

for Toolholder

Type 356
 357

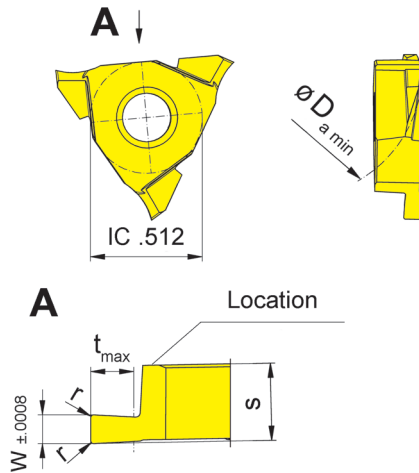

Indexability length
 $\pm .0008''$

R = right hand version shown

Part number	w	r	t_{\max}	$D_{a \min}$	s	Size	TH35	TN35
RA315.2015.02R	.059	.008	.079	.787	.213	05	Δ/\blacktriangle	
RA315.3020.02R	.079	.008	.118	1.181	.213	05	Δ/\blacktriangle	x/x
RA315.3030.02R	.118	.008	.118	1.181	.213	05	Δ/\blacktriangle	

\blacktriangle on stock Δ 4 weeks x upon request

- recommended
- alternative recommendation
- not suitable

- uncoated grades
- coated grades
- brazed/Cermet

Dimensions in inch

	TH35	TN35
P	●	●
M	●	●
K	●	●
N	●	●
S	●	●
H	-	-

Carbide grades





T

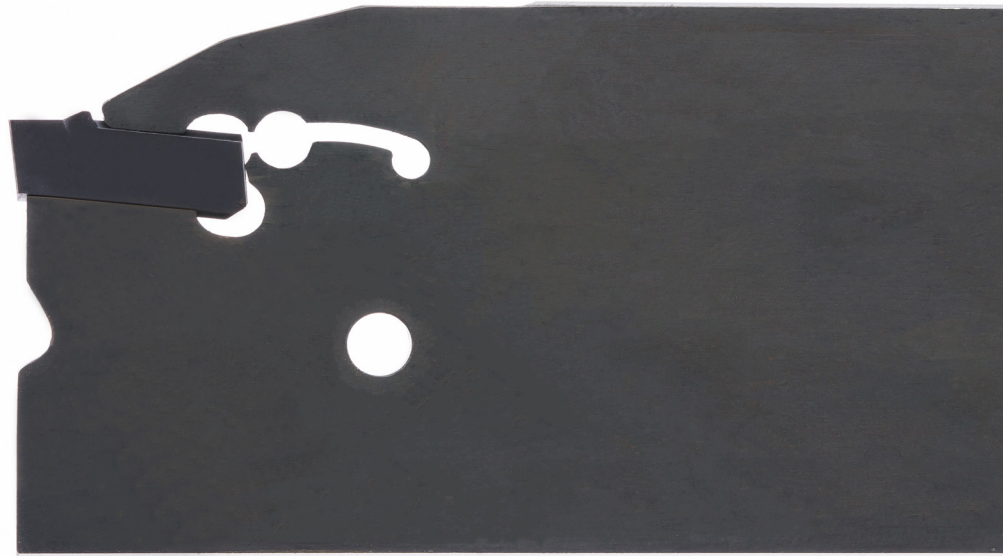

U

System	Page
100	U2
123/223	U42
S224	U52
264	U72
274	U80
229	U96
312	U112
316	U128

Toolholder
H100

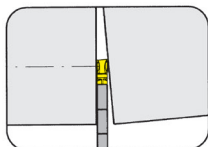

Page
U4-U7, U18

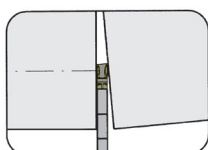

Page
U8-U15

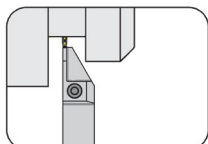

Page
U24, U28, U35-U37

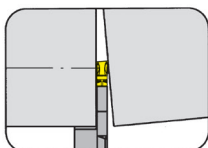

Page
U39

Toolholder
For Reika

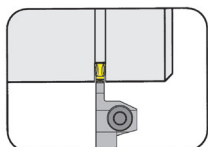

Page
U16 - U17

Toolholder
Y-Axis Part Off

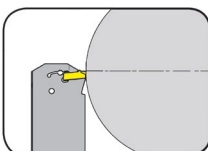

Page
U20

Toolholder
H100

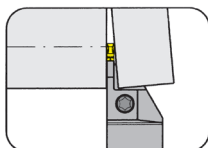

Page
U20-U23, U25-U27
U29-U30, U34-U37

U

100



Toolholder with Inserts

Width of groove .079 - .630"

Depth of groove up to 2.165"

U

Toolholder

H100

with self clamping

Depth of groove up to
Width of groove

55 mm
2 - 5 mm

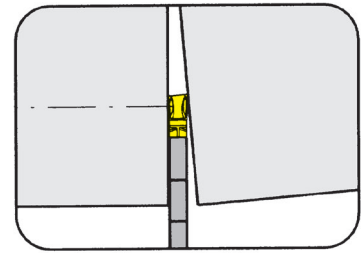

for Insert

Type S100

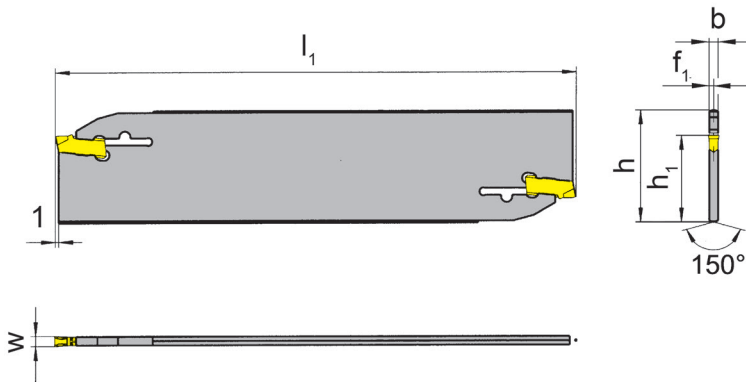

Part number	h	b	l ₁	h ₁	f ₁	t _{max}	Size
H100.2601.01	26	1.5	110	21.4	.75	25.0	01
H100.3201.01	32	1.5	150	24.8	.75	25.0	01
H100.2602.02	26	1.9	110	21.4	.95	37.5	02
H100.3202.02	32	1.9	150	24.8	.95	50.0	02
H100.2603.03	26	2.3	110	21.4	1.15	37.5	03
H100.3203.03	32	2.3	150	24.8	1.15	50.0	03
H100.2604.04	26	3.1	110	21.8	1.65	40.0	04
H100.3204.04	32	3.1	160	24.8	1.65	55.0	04
H100.3205.05	32	3.9	160	24.8	2.00	55.0	05

Further sizes upon request

w see inserts

Dimensions in mm

Note:

Wrench **P39L** is not combined with toolholder - separate order required!

Toolholder

H100

with through coolant supply

Depth of groove up to
Width of Groove

60 mm
2.5 - 4 mm

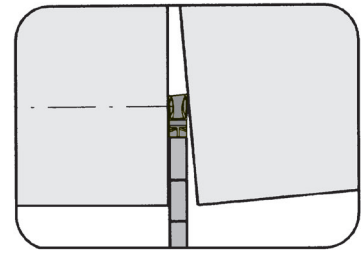

for Insert

Type S100
S100...IK

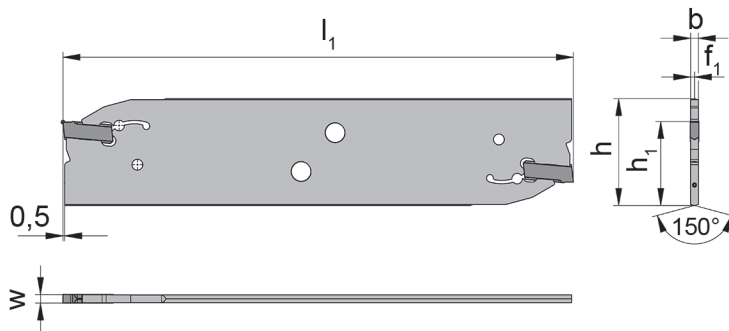

Part number	h	b	l ₁	h ₁	f ₁	t _{max}	Size
H100.2602.8.02.IK	26	1.9	110	21.4	.95	35	02
H100.2603.8.03.IK	26	2.3	110	21.4	1.15	35	03
H100.2604.8.04.IK	26	3.1	110	21.4	1.55	35	04
H100.3202.8.02.IK	32	1.9	150	24.8	.95	55	02
H100.3203.8.03.IK	32	2.3	150	24.8	1.15	60	03
H100.3204.8.04.IK	32	3.1	150	24.8	1.55	60	04

Further sizes upon request

Dimensions in mm

Wrench **P101.02** is not combined with tool holder - separate order required!

Spare Parts

Toolholder	Allen wrench	Coolant plug
H100...	SW3,0 DIN911	020.IK01.5732



Toolholder

H100

Depth of groove up to
Width of groove

25 mm
2 - 2.5 mm

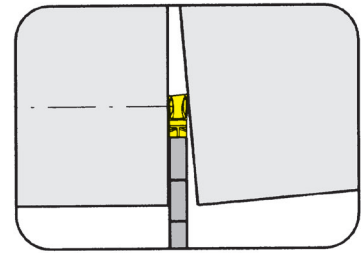

for Insert

Type S100

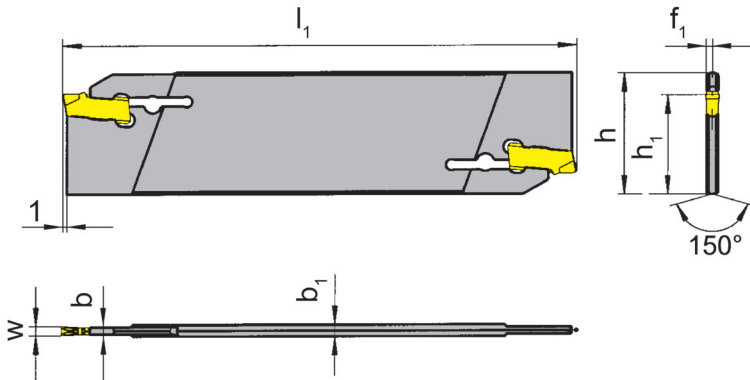

Part number	h	b	l_1	h_1	f_1	t_{max}	b_1	Size
H100.2603.01	26	1.5	110	21.4	1.15	21	2.3	01
H100.3203.01	32	1.5	150	24.8	1.15	25	2.3	01
H100.2603.02	26	1.9	110	21.4	1.15	21	2.3	02
H100.3203.02	32	1.9	150	24.8	1.15	25	2.3	02

Further sizes upon request

Dimensions in mm

Wrench **P39L** is not combined with toolholder - separate order required!

Toolholder

H100

Width of groove	8 - 12 mm
-----------------	-----------

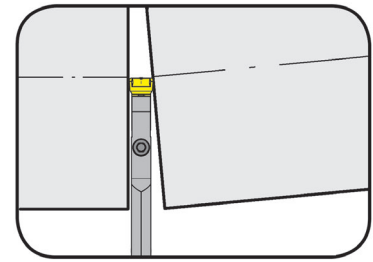

for Insert

Type S100

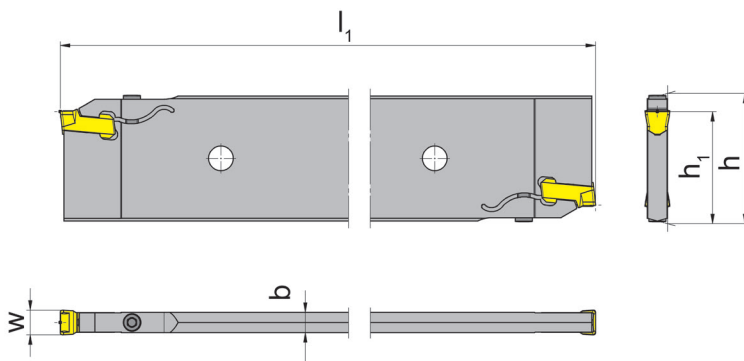

Part number	h	b	l ₁	h ₁	Width of groove
H100.5208.26.08	52.6	7.4	260	45	8
H100.5210.26.10	52.6	8.2	260	45	10
H100.5212.26.12	52.6	10.4	260	45	12

Further sizes upon request

Dimensions in mm

For torque specification of the screw, please see Technical Instructions.

Spare Parts

Toolholder	Clamping Screw	TORX PLUS® Wrench
H100...	5.13 T20P	T20PQ



Toolholder

H100

with self clamping

Depth of groove up to
Width of groove

34 mm
2 - 4 mm

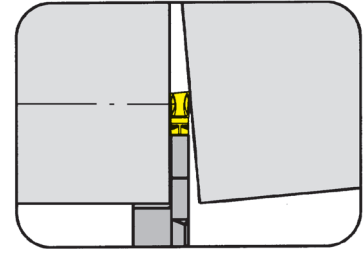

for Insert

Type S100

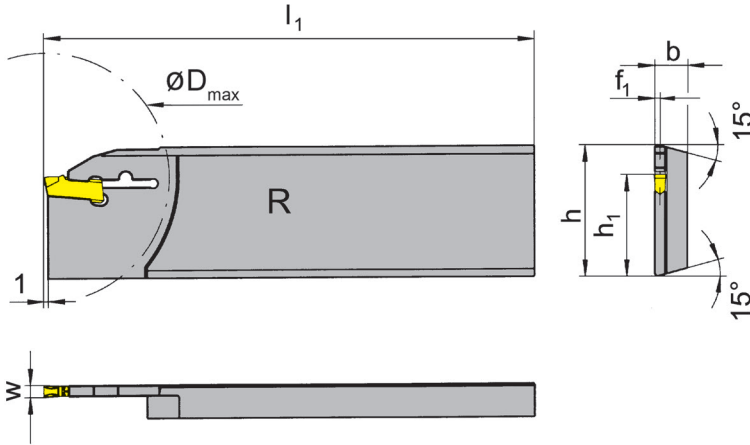

R = right hand version shown

L = left hand version

Part number	h	b	l_1	h_1	f_1	t_{max}	D_{max}	Size
R/LH100.2608.31	26	7.9	110	21.4	.75	21	42	01
R/LH100.3208.31	32	7.9	112	24.8	.75	25	50	01
R/LH100.2608.32	26	7.9	110	21.4	.95	25	50	02
R/LH100.3208.32	32	7.9	112	24.8	.95	34	68	02
R/LH100.2608.33	26	7.9	110	21.4	1.15	25	50	03
R/LH100.3208.33	32	7.9	112	24.8	1.15	34	68	03
R/LH100.2608.34	26	7.9	110	21.4	1.55	25	50	04
R/LH100.3208.34	32	7.9	112	24.8	1.55	34	68	04

State R or L version

w see inserts

Dimensions in mm

Further sizes upon request

Note:

Wrench **P39L** is not combined with toolholder - separate order required!

Recommended fro Traub machine types:

R/L100.2608.31-34	R/LH100.3208.31-34
TNC 30	TNC 42/65
TNM 28	TNM 42/65
TNS 26	TNS 65
TNS 30/42	TNS 60
TNA 300	TNA 400
TNK 28/36	TNA 300
TNL 26	

Spare Parts

Toolholder	Wrench
R/LH100...	P39L

Toolholder

H100

with self clamping

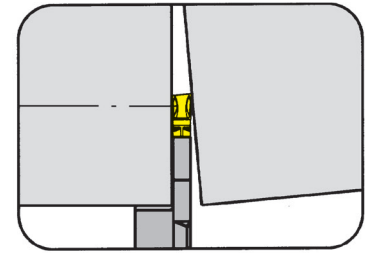

Depth of groove up to
Width of groove

34 mm
2 - 4 mm

for Insert

Type S100

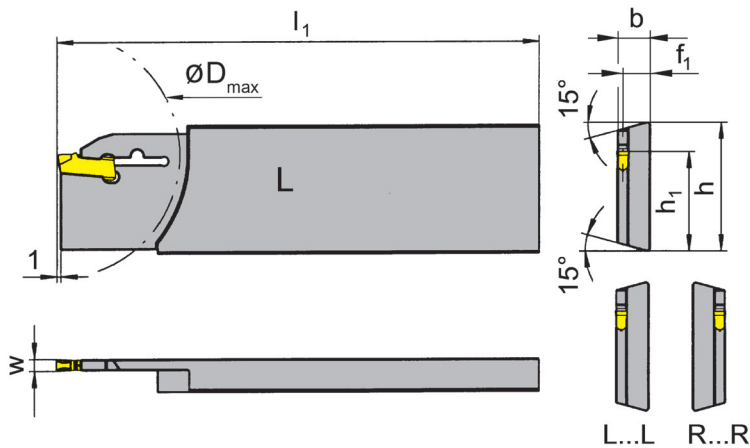

L = left hand version shown

R = right hand version

Part number	h	b	l ₁	h ₁	f ₁	t _{max}	D _{max}	Size
LH100.2608.31L	26	7.9	110	21.4	7.15	21	42	01
RH100.2608.31R	26	7.9	110	21.4	7.15	21	42	01
LH100.3208.31L	32	7.9	112	24.8	7.15	25	50	01
RH100.3208.31R	32	7.9	112	24.8	7.15	25	50	01
LH100.2608.32L	26	7.9	110	21.4	6.95	25	50	02
RH100.2608.32R	26	7.9	110	21.4	6.95	25	50	02
LH100.3208.32L	32	7.9	112	24.8	6.95	34	68	02
RH100.3208.32R	32	7.9	112	24.8	6.95	34	68	02
LH100.2608.33L	26	7.9	110	21.4	6.75	25	50	03
RH100.2608.33R	26	7.9	110	21.4	6.75	25	50	03
LH100.3208.33L	32	7.9	112	24.8	6.75	34	68	03
RH100.3208.33R	32	7.9	112	24.8	6.75	34	68	03
LH100.2608.34L	26	7.9	110	21.4	6.35	25	50	04
RH100.2608.34R	26	7.9	110	21.4	6.35	25	50	04
LH100.3208.34L	32	7.9	112	24.8	6.35	34	68	04
RH100.3208.34R	32	7.9	112	24.8	6.35	34	68	04

Further sizes upon request

w see inserts

Dimensions in mm

Note:

Wrench **P39L** is not combined with toolholder - separate order required!



Toolholder

H100

with self clamping

Depth of groove up to
Width of groove

41 mm
4 mm

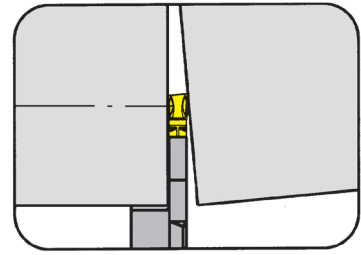

for Insert

Type S100

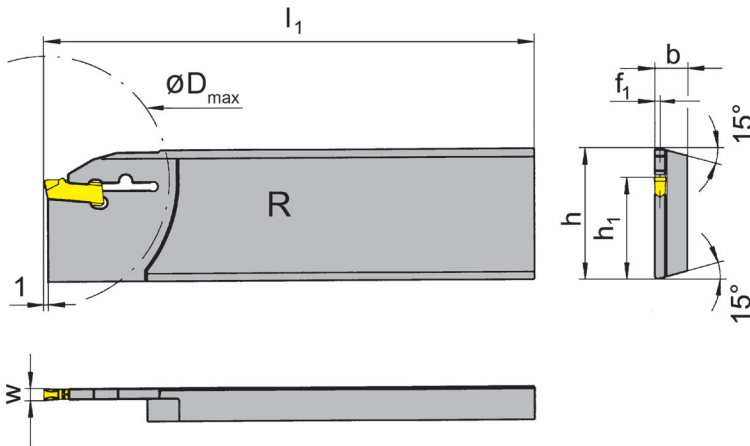

R = right hand version

Part number	h	b	l ₁	h ₁	f ₁	t _{max}	D _{max}	Size
RH100.3208.2.44	32	7.9	160	24.8	1.55	41	80	04
RH100.3208.44	32	7.9	130	24.8	1.55	41	80	04

Further sizes upon request

w see inserts

Dimensions in mm

Note:

Wrench **P39L** is not combined with toolholder - separate order required!

Toolholder

H100

with screwed clamping

Depth of groove up to
Width of groove

32.5 mm
2 - 3 mm

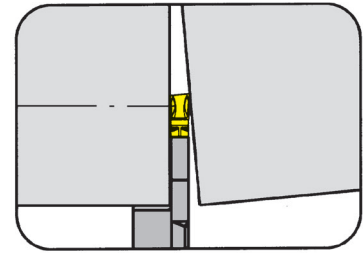

for Insert

Type S100

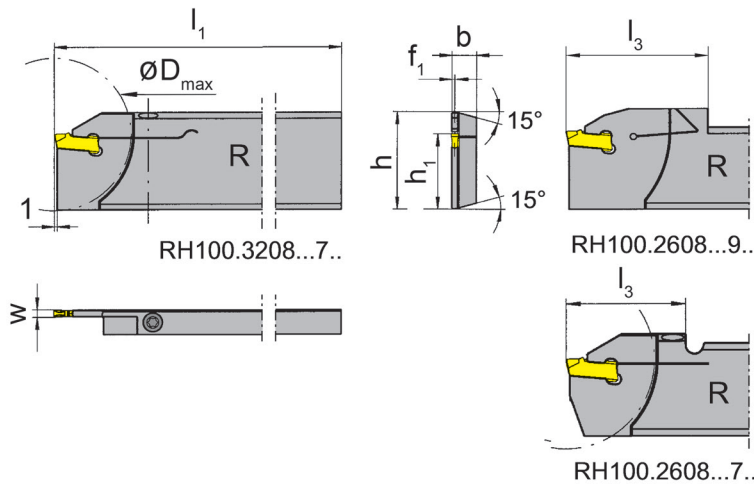

R = right hand version shown

L = left hand version

Part number	h	b	l ₁	h ₁	f ₁	l ₃	t _{max}	D _{max}	Size
R/LH100.2608.71	26	7.9	110	21.4	.75	33.8	25.0	50	01
R/LH100.3208.71	32	7.9	112	24.8	.75	33.8	25.0	50	01
R/LH100.2608.72	26	7.9	110	21.4	.95	33.8	25.0	50	02
R/LH100.3208.72	32	7.9	112	24.8	.95	33.8	25.0	50	02
R/LH100.2608.93	26	8.0	112	21.4	1.15	40.0	25.0	50	03
R/LH100.3208.93	32	8.0	112	24.8	1.15	40.0	32.5	65	03

State R or L version

w see inserts

Dimensions in mm

Further sizes upon request

For torque specification of the screw, please see Technical Instructions.

Spare Parts

Toolholder	Clamping Screw	TORX PLUS® Wrench	Pin
R/LH100...	4.15T15P	T15PQ	
R/LH100...93	030.0413.T15P	T15PQ	020.0040.0999

Toolholder

H100

with screwed clamping

Depth of groove up to
Width of groove

32.5 mm
2 - 3 mm

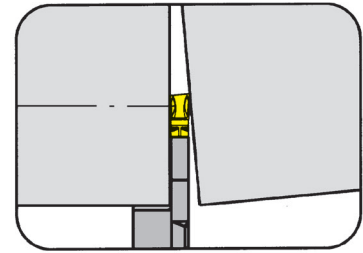

for Insert

Type S100

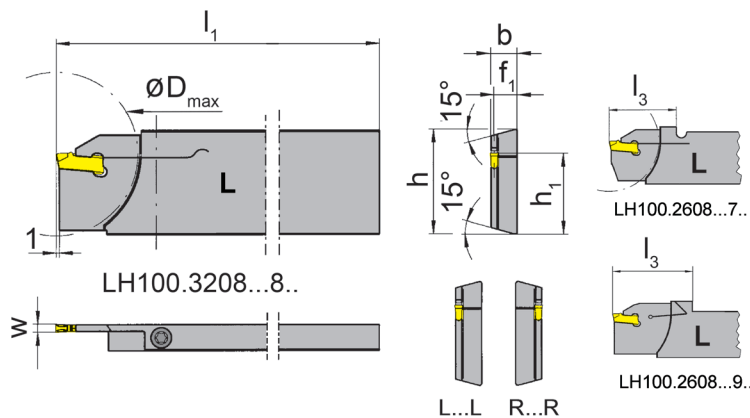

L = left hand version shown

R = right hand version

Part number	h	b	l ₁	h ₁	f ₁	l ₃	t _{max}	D _{max}	Size
LH100.2608.71L	26	7.9	110	21.4	7.15	33.8	25.0	50	01
LH100.3208.71L	32	7.9	112	24.8	7.15	33.8	25.0	50	01
RH100.2608.71R	26	7.9	110	21.4	7.15	33.8	25.0	50	01
RH100.3208.71R	32	7.9	112	24.8	7.15	33.8	25.0	50	01
LH100.2608.72L	26	7.9	110	21.4	6.95	33.8	25.0	50	02
LH100.3208.72L	32	7.9	112	24.8	6.95	33.8	25.0	50	02
RH100.2608.72R	26	7.9	110	21.4	6.95	33.8	25.0	50	02
RH100.3208.72R	32	7.9	112	24.8	6.95	33.8	25.0	50	02
LH100.2608.93L	26	8.0	115	21.4	6.85	40.0	25.0	50	03
LH100.3208.93L	32	8.0	115	24.8	6.85	42.0	32.5	65	03
RH100.2608.93R	26	8.0	115	21.4	6.85	40.0	25.0	50	03
RH100.3208.93R	32	8.0	115	24.8	6.85	42.0	32.5	65	03

Further sizes upon request

w see inserts

Dimensions in mm

For torque specification of the screw, please see Technical Instructions.

Spare Parts

Toolholder	Clamping Screw	TORX PLUS® Wrench	Pin
R/LH100...	4.15T15P	T15PQ	
R/LH100...93R/L	030.0413.T15P	T15PQ	020.0040.0999

Toolholder

H100

Depth of groove up to
Width of groove

32.5 mm
3 - 4 mm

for machines TRAUB (TNX65)

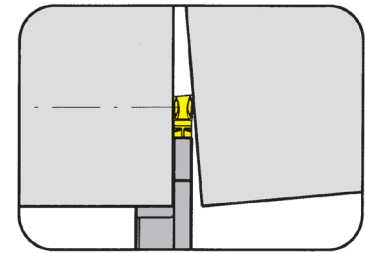

for Insert

Type S100

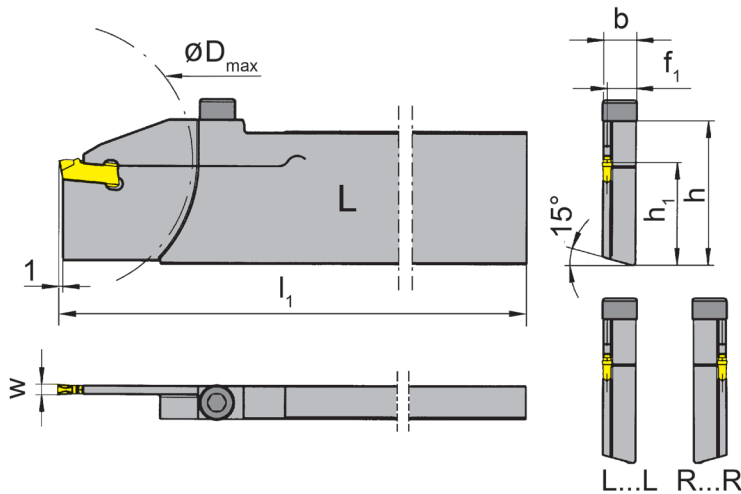

L = left hand version shown

R = right hand version

Part number	h	b	l_1	h_1	f_1	t_{max}	D_{max}	Size
LH100.3280.73L	32	7.9	130	24.8	6.75	32.5	65	03
RH100.3280.73R	32	7.9	130	24.8	6.75	32.5	65	03
LH100.3280.74L	32	7.9	130	24.8	6.35	32.5	65	04
RH100.3280.74R	32	7.9	130	24.8	6.35	32.5	65	04

Further sizes upon request

w see inserts

Dimensions in mm

For torque specification of the screw, please see Technical Instructions.

Spare Parts

Toolholder	Allen wrench
LH100...	SW4,0 DIN911



Toolholder

H100

with screwed clamping

Depth of groove up to
Width of groove

33.5 mm
3 - 4 mm

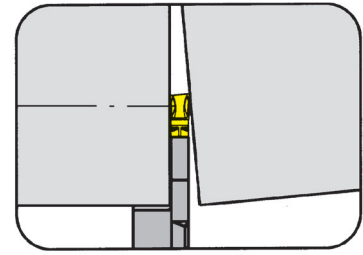

for Insert

Type S100

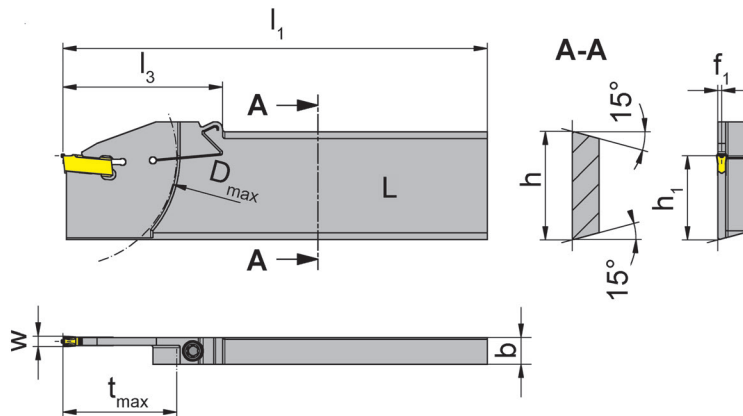

R = right hand version shown

L = left hand version

for machines TRAUB and
INDEX

Part number	h	b	l ₁	h ₁	f ₁	l ₃	t _{max}	D _{max}	Machine type	Size
R/LH100.3208.83	32	8	125	24.8	1.15	47	33.5	65	TraubTNX65/42, IndexC65	03
LH100.3208.15.83	32	8	150	24.8	1.15	47	33.5	65	TraubTNX65/42, IndexC65	03
R/LH100.3208.84	32	8	125	24.8	1.50	47	33.5	65	TraubTNX65/42, IndexC65	04
LH100.3208.15.84	32	8	150	24.8	1.15	47	33.5	65	TraubTNX65/42, IndexC65	04

State R or L version

w see inserts

Dimensions in mm

Further sizes upon request

For torque specification of the screw, please see Technical Instructions.

Spare Parts

Toolholder	Clamping Screw	TORX PLUS® Wrench
R/LH100...	030.505P.0718	T15PQ

Toolholder

H100

with screwed clamping

Depth of groove up to
Width of groove

41 mm
3 - 4 mm

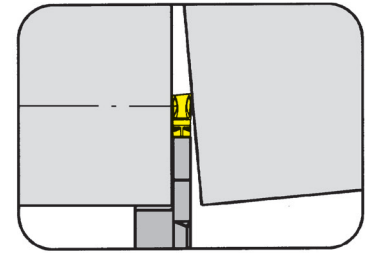

for Insert

Type S100

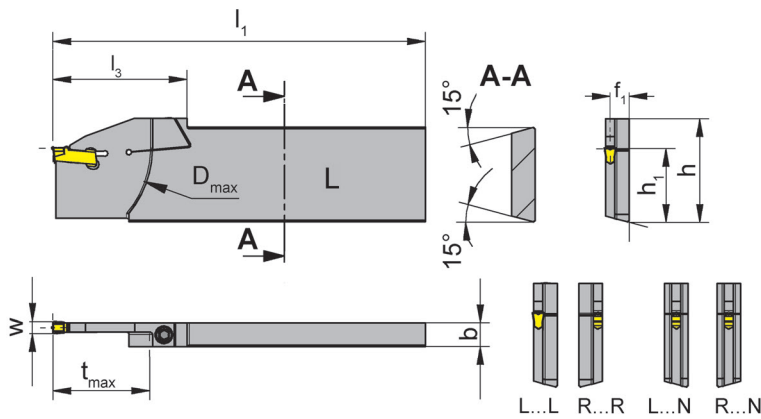

for machines TRAUB and
INDEX

L = left hand version shown

R = right hand version

Part number	h	b	l ₁	h ₁	f ₁	l ₃	t _{max}	D _{max}	Machine type	Size
LH100.3208.83L	32	8	125	24.8	6.75	47.0	33.5	65	TraubTNX65/42, IndexC65	03
RH100.3208.83R	32	8	125	24.8	6.75	47.0	33.5	65	TraubTNX65/42, IndexC65	03
R/LH100.3208.83N	32	8	125	24.8	4.00	47.0	33.5	65	TraubTNX65/42, IndexC65	03
LH100.3208.84L	32	8	125	24.8	6.35	47.0	33.5	65	TraubTNX65/42, IndexC65	04
RH100.3208.84R	32	8	125	24.8	6.35	47.0	33.5	65	TraubTNX65/42, IndexC65	04
R/LH100.3208.84N	32	8	134	24.8	4.00	54.5	41.0	80	TraubTNX80/65	04

Further sizes upon request

w see inserts

Dimensions in mm

For torque specification of the screw, please see Technical Instructions.

Spare Parts

Toolholder	Clamping Screw	TORX PLUS® Wrench
R/LH100...	030.505P.0718	T15PQ



Toolholder

H100

Depth of groove up to
Width of groove

10 mm
3 mm

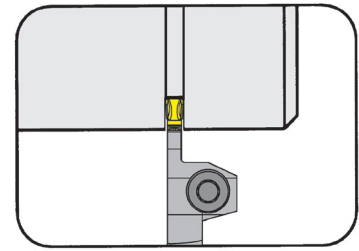

for Insert

Type S100

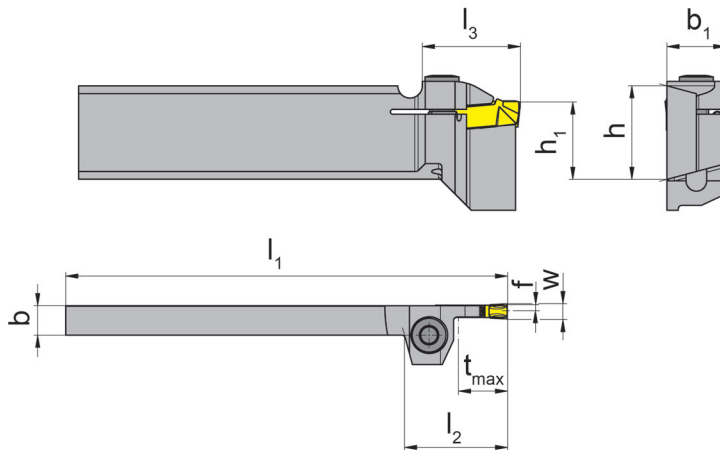

L = left hand version shown

for machines REIKA

Part number	h	b	l ₁	h ₁	l ₂	f	l ₃	t _{max}	b ₁	Size
LH100.1908.R.13	19	8	90	15.7	16	1.15	20	10	12	03
LH100.3208.R.13	32	8	110	24.8	16	1.15	20	10	12	03

Further sizes upon request

w see inserts

Dimensions in mm

For torque specification of the screw, please see Technical Instructions.

Spare Parts

Toolholder	Clamping Screw	TORX PLUS® Wrench
LH100.1908.R.13	5.17T20P	T20PW
LH100.3208.R.13	5.17T20P	T20PQ

Toolholder

H100

Depth of groove up to
Width of groove

65 mm
8 - 12 mm

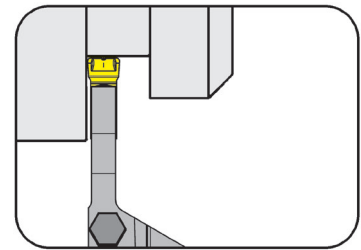

for Insert

Type S100

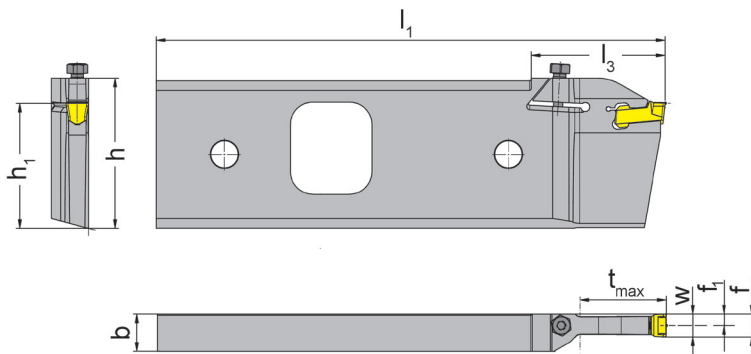

for machines REIKA

L = left hand version shown

Part number	h	b	l_1	h_1	f_1	l_3	f	t_{max}	Size
LH100.5517.38.8.08	65	16.4	224	55	4	59	$f_1+w/2$	38	08
LH100.5517.54.8.08	65	16.4	224	55	4	75	$f_1+w/2$	54	08
LH100.5517.38.8.10	65	16.4	224	55	5	59	$f_1+w/2$	38	10
LH100.5517.54.8.10	65	16.4	224	55	5	75	$f_1+w/2$	54	10
LH100.5517.44.8.12	65	16.4	224	55	6	65	$f_1+w/2$	44	12
LH100.5517.65.8.12	65	16.4	224	55	6	86	$f_1+w/2$	65	12

Further sizes upon request

Dimensions in mm

For torque specification of the screw, please see Technical Instructions.

Spare Parts

Toolholder	Clamping Screw	TORX PLUS® Wrench
LH100...	030.6075.T20P	T20PQ



Toolholder

H100

with self clamping

Depth of groove up to
Width of groove

38 mm
2 - 3 mm

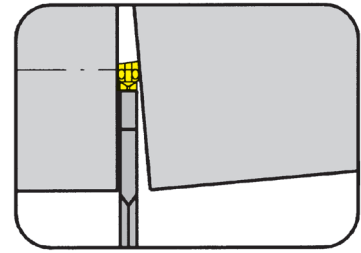

for Insert

Type S100

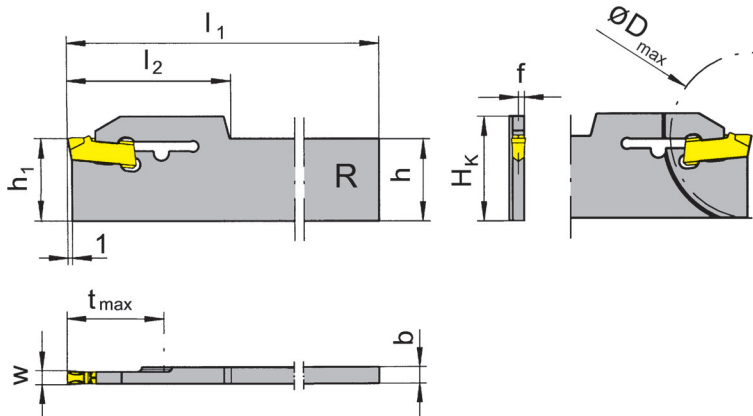

R = right hand version

Part number	H _k	b	l ₁	h ₁	f	l ₂	t _{max}	D _{max}	h	Size
RH100.1703.21	22.1	3.2	110	17.4	.75	32.0	17.5	35	17.4	01
RH100.2203.21	26.9	3.2	150	22.2	.75	32.0	38.0	50	22.1	01
RH100.1703.33	22.1	3.2	110	17.4	1.15	34.5	30.0	60	17.4	03
RH100.2203.33	26.9	3.2	150	22.2	1.15	34.5	38.0	76	22.1	03

Further sizes upon request

w see inserts

Dimensions in mm

Note:

Wrench **P39L** is not combined with blade R/LH100...33 - separate order required!

Grooving and Parting off (external)



Toolholder

H100

with through coolant supply

Depth of groove up to
Width of groove

60 mm
3 - 4 mm

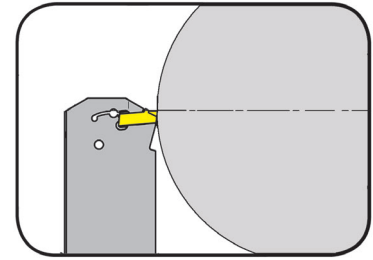

for Insert

Type S100
S100...IK

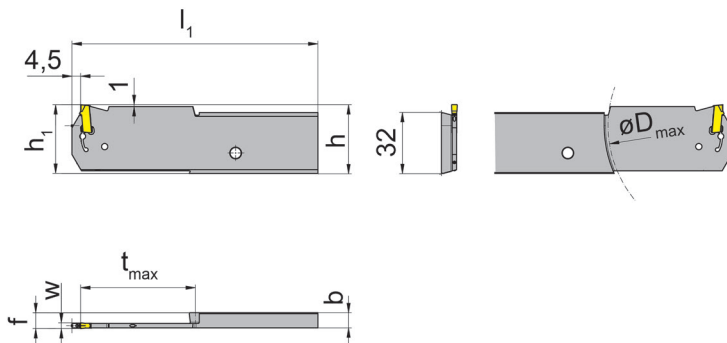

Y Axis Part Off
Coolant through insert

R = right hand version shown

L = left hand version

Part number	b	l_1	h_1	f	t_{max}	D_{max}	Size
R/LH100.3208.Y.60.3.83.IK	7.9	128.5	36	8.25	60	120	03
R/LH100.3208.Y.60.4.83.IK	7.9	128.5	36	8.25	60	120	03
R/LH100.3208.Y.60.3.84.IK	7.9	128.5	36	8.25	60	120	04
R/LH100.3208.Y.60.4.84.IK	7.9	128.5	36	8.25	60	120	04

Further sizes upon request

w see inserts

Dimensions in mm

*Coolant through insert

Wrench **P101.02** is not combined with tool holder - separate order required!

Spare Parts

Toolholder	Coolant plug	Threaded Pin
R/LH100.3208.Y.60.3....	020.IK01.5732	
R/LH100.3208.Y.60.4.83.IK	020.IK01.5732	1.6.04.913
R/LH100.3208.Y.60.4.84.IK	020.IK01.5732	2.03.913



Toolholder

H100

with screwed clamping

Depth of groove up to
Width of groove

21 mm
2 mm

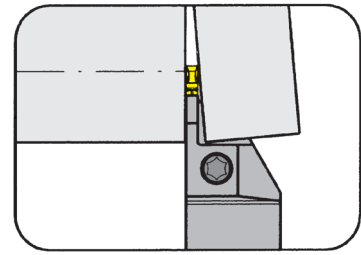

for Insert

Type S100

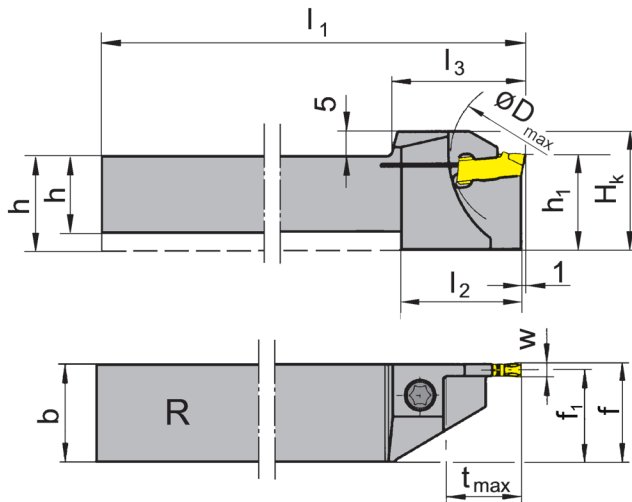

R = right hand version shown

L = left hand version

Part number	h	b	l ₁	l ₂	l ₃	h ₁	f ₁	f	t _{max}	D _{max}	H _K	Size
R/LH100.1010.01	10	10	125	19	21.0	13	9.25	f ₁ +w/2	10.5	21	18	01
R/LH100.1010.11	10	10	125	21	23.0	16	9.25	f ₁ +w/2	13.0	42	21	01
R/LH100.1212.01	12	12	125	21	23.0	16	11.25	f ₁ +w/2	13.0	26	21	01
R/LH100.1212.11	12	12	125	21	26.0	16	11.25	f ₁ +w/2	16.0	42	21	01
R/LH100.1616.11	16	16	125	24	26.0	20	15.25	f ₁ +w/2	16.0	42	25	01
R/LH100.1616.21	16	16	125	30	33.5	20	15.25	f ₁ +w/2	21.0	42	25	01
R/LH100.2020.11	20	20	125	-	33.5	20	19.25	f ₁ +w/2	16.0	42	25	01
R/LH100.2020.21	20	20	125	-	33.5	20	19.25	f ₁ +w/2	21.0	42	25	01
R/LH100.2525.21	25	25	150	-	33.5	25	24.30	f ₁ +w/2	21.0	42	30	01

State R or L version

w see inserts

Dimensions in mm

Further sizes upon request

For torque specification of the screw, please see Technical Instructions.

Spare Parts

Toolholder	Clamping Screw	TORX PLUS® Wrench
R/LH100...	4.15T15P	T15PQ

Toolholder

H100

with screwed clamping

Depth of groove up to
Width of groove

21 mm
2 mm

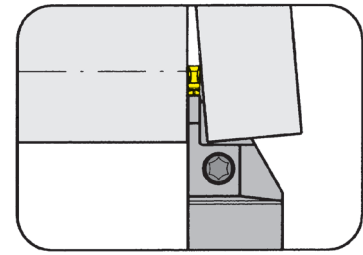

for Insert

Type S100

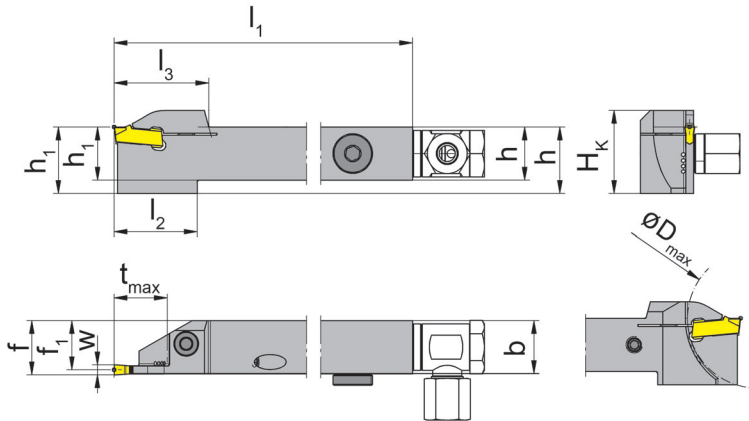

with through coolant supply

R = right hand version shown

L = left hand version

Part number	h	b	l ₁	l ₂	l ₃	h ₁	f ₁	f	t _{max}	D _{max}	H _k	Size
R/LH100.1212.01.IK	12	12	125	21	23.0	12	11.25	f ₁ +w/2	13	26	21	01
R/LH100.1212.11.IK	12	12	125	21	26.0	12	11.25	f ₁ +w/2	16	42	21	01
R/LH100.1616.11.IK	16	16	125	24	26.0	16	15.25	f ₁ +w/2	16	42	25	01
R/LH100.1616.21.IK	16	16	125	30	33.5	16	15.25	f ₁ +w/2	21	42	25	01
R/LH100.2020.11.IK	20	20	125	-	33.5	20	19.25	f ₁ +w/2	16	42	25	01
R/LH100.2020.21.IK	20	20	125	-	33.5	20	19.25	f ₁ +w/2	21	42	25	01
R/LH100.2525.21.IK	25	25	150	-	33.5	25	24.30	f ₁ +w/2	21	42	30	01

State R or L version

w see inserts

Dimensions in mm

Further sizes upon request

For torque specification of the screw, please see Technical Instructions.

Spare Parts

Toolholder	Clamping Screw	Coolant supply	TORX PLUS® Wrench	Sealing plug	Threaded Pin
R/LH100.1212...	4.15T15P	004.00.61	T15PQ		
R/LH100...	4.15T15P	004.00.16	T15PQ	004.00.26	18.05.913

Toolholder

H100

Depth of groove up to 32.5 mm
Width of groove 2.5 mm

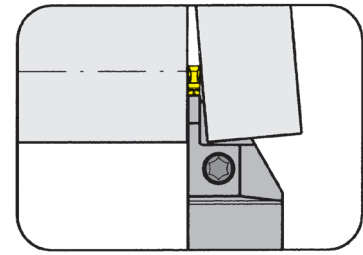

for Insert

Type S100

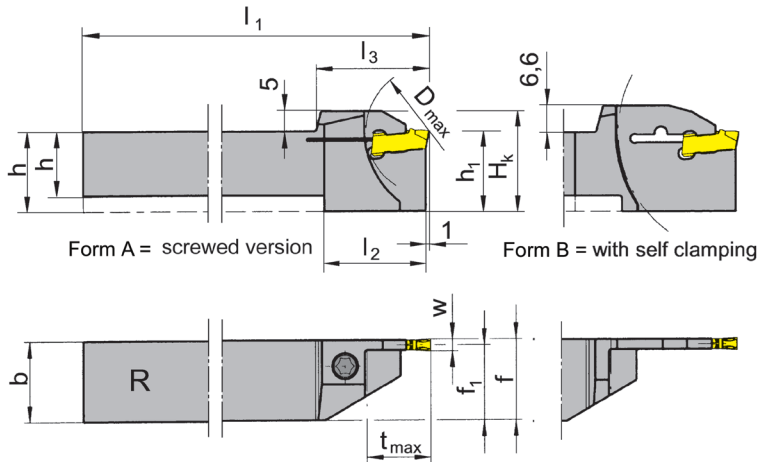

R = right hand version shown

L = left hand version

Part number	h	b	l ₁	l ₂	l ₃	h ₁	f ₁	f	t _{max}	D _{max}	H _K	Form	Size
R/LH100.1212.02	12	12	125	21	23.0	16	11.05	f ₁ +w/2	13.0	25	21.0	A	02
R/LH100.1212.12	12	12	125	24	26.0	16	11.05	f ₁ +w/2	16.0	42	25.0	A	02
R/LH100.1616.02	16	16	125	19	21.0	20	15.05	f ₁ +w/2	10.5	42	25.0	A	02
R/LH100.1616.12	16	16	125	24	26.0	20	15.05	f ₁ +w/2	16.0	42	25.0	A	02
R/LH100.1616.22	16	16	125	30	33.5	20	15.05	f ₁ +w/2	21.0	42	25.0	A	02
R/LH100.2020.12	20	20	125	-	26.0	20	19.05	f ₁ +w/2	16.0	42	25.0	A	02
R/LH100.2020.22	20	20	125	-	33.5	20	19.05	f ₁ +w/2	21.0	42	25.0	A	02
R/LH100.2020.32	20	20	125	35	38.5	25	19.05	f ₁ +w/2	32.5	65	31.6	B	02
R/LH100.2525.22	25	25	150	-	33.5	25	24.05	f ₁ +w/2	21.0	42	30.0	A	02

State R or L version

w see inserts

Dimensions in mm

Further sizes upon request

Ordering note:

Wrench **P39L** is not combined with blade R/LH100...32 - separate order required!

For torque specification of the screw, please see Technical Instructions.

Spare Parts

Toolholder	Clamping Screw	TORX PLUS® Wrench	Wrench
R/LH100...	4.15T15P	T15PQ	
R/LH100.2020.32			P39L

Toolholder

H100

with screwed clamping

Depth of groove up to
Width of groove

21 mm
2.5 mm

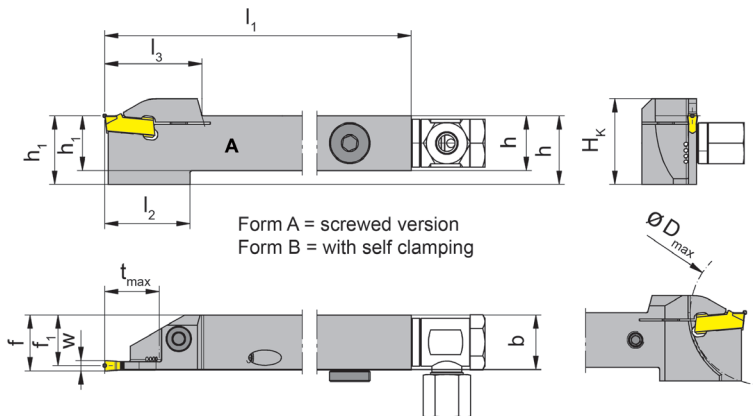
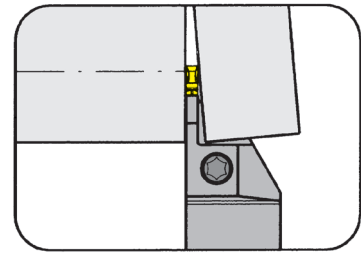

with through coolant supply

R = right hand version shown

L = left hand version

Part number	h	b	l ₁	l ₂	l ₃	h ₁	f ₁	f	t _{max}	D _{max}	H _K	Form	Size
R/LH100.1212.02.IK	12	12	125	21	23.0	16	11.05	f ₁ +w/2	13.0	25	21	A	02
R/LH100.1616.02.IK	16	16	125	19	21.0	20	15.05	f ₁ +w/2	10.5	42	25	A	02
R/LH100.1212.12.IK	12	12	125	24	26.0	16	11.05	f ₁ +w/2	16.0	42	25	A	02
R/LH100.1616.12.IK	16	16	125	24	28.5	20	15.05	f ₁ +w/2	16.0	42	25	A	02
R/LH100.2020.12.IK	20	20	125	-	26.0	20	19.05	f ₁ +w/2	16.0	42	25	A	02
R/LH100.1616.22.IK	16	16	125	30	33.5	20	15.05	f ₁ +w/2	21.0	42	25	A	02
R/LH100.2020.22.IK	20	20	125	-	33.5	20	19.05	f ₁ +w/2	21.0	42	25	A	02
R/LH100.2525.22.IK	25	25	150	-	33.5	25	24.05	f ₁ +w/2	21.0	42	30	A	02

State R or L version

w see inserts

Dimensions in mm

Further sizes upon request

For torque specification of the screw, please see Technical Instructions.

Spare Parts

Toolholder	Clamping Screw	Coolant supply	TORX PLUS® Wrench	Sealing plug	Threaded Pin
R/LH100.1212.02/.12.IK	4.15T15P	004.00.61	T15PQ		
R/LH100.1616...02/.12.IK	4.15T15P	004.00.16	T15PQ	004.00.26	18.05.913
R/LH100.2020.12.IK	4.15T15P	004.00.16	T15PQ	004.00.26	18.05.913
R/LH100.2020.22.IK	5.17T20P	004.00.16	T20PQ	004.00.26	18.05.913
R/LH100.2525.22.IK	4.15T15P	004.00.16	T15PQ	004.00.26	18.05.913

Toolholder

H100

with screwed clamping

Depth of groove up to
Width of groove

13.5 mm
3 mm

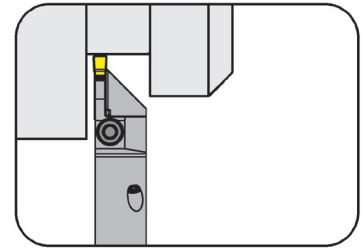

for Insert

Type S100

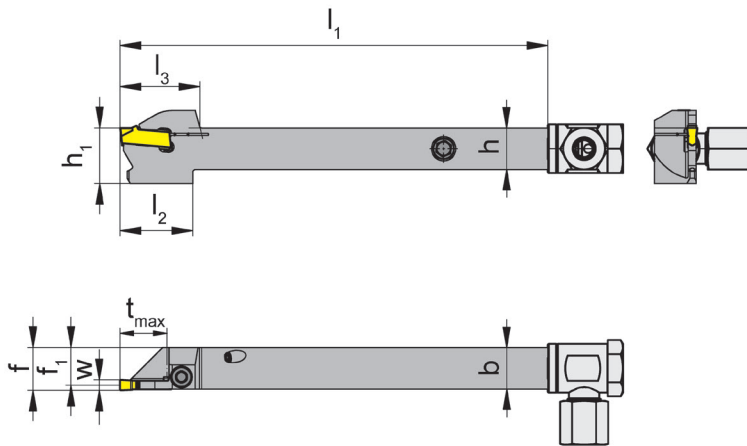

R = right hand version shown

L = left hand version

with through coolant supply

Part number	h	b	l ₁	l ₂	l ₃	h ₁	f ₁	f	t _{max}	D _{max}	Size
R/LH100.1212.5.23.IK	12	12	125	21	23	16	10.85	f ₁ +w/2	13.5	26	03

State R or L version

w see inserts

Dimensions in mm

Further sizes upon request

Spare Parts

Toolholder	Clamping Screw	Coolant supply	TORX PLUS® Wrench
R/LH100.1212.5.23.IK	4.15T15P	004.00.61	T15PQ

Toolholder

H100

with screwed clamping

Depth of groove up to
Width of groove

17 mm
2 - 3 mm

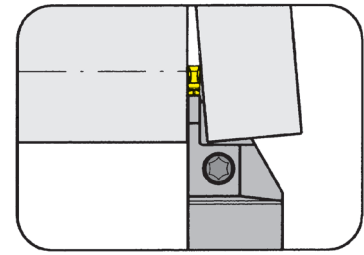

for Insert

Type S100

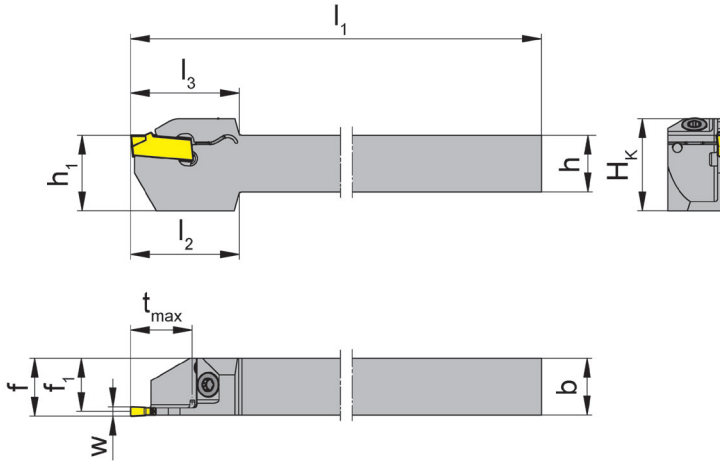

R = right hand version shown

L = left hand version

for Swiss type machines

Part number	h	b	l ₁	l ₂	l ₃	h ₁	f ₁	f	t _{max}	D _{max}	H _k	Size
R/LH100.1212.24.61	12	12	125	23	23	16	11.25	f ₁ +w/2	13	26	19.5	02
R/LH100.1616.24.61	16	16	125	23	-	16	15.25	f ₁ +w/2	13	26	19.5	02
R/LH100.1212.32.63	12	12	125	27	24	16	10.85	f ₁ +w/2	17	34	19.5	03
R/LH100.1616.32.63	16	16	125	27	-	16	14.85	f ₁ +w/2	17	34	19.5	03

State R or L version

w see inserts

Dimensions in mm

Further sizes upon request

For torque specification of the screw, please see Technical Instructions.

Spare Parts

Toolholder	Clamping Screw	TORX PLUS® Wrench
R/LH100...	3.5.12T10EP	T10PL



Toolholder

H100

Depth of groove up to
Width of groove

32.5 mm
3 mm

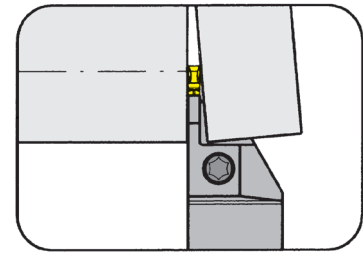

for Insert

Type S100

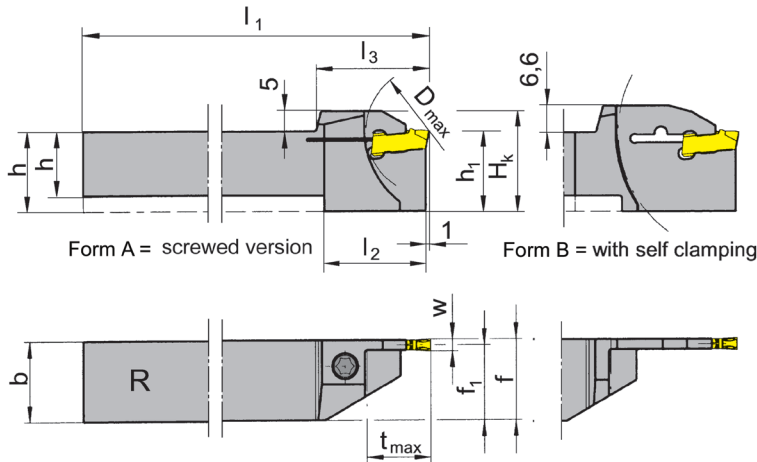

R = right hand version shown

L = left hand version

Part number	h	b	l ₁	l ₂	l ₃	h ₁	f ₁	f	t _{max}	D _{max}	H _K	Form	Size
R/LH100.1212.03	12	12	125	21.0	23.0	16	10.85	f ₁ +w/2	13.0	26	25.0	A	03
R/LH100.1616.03	16	16	125	19.5	23.0	20	14.85	f ₁ +w/2	10.5	42	25.0	A	03
R/LH100.1616.13	16	16	125	25.0	28.5	20	14.85	f ₁ +w/2	16.0	42	25.0	A	03
R/LH100.1616.23	16	16	125	30.0	33.5	20	14.85	f ₁ +w/2	21.0	42	25.0	A	03
R/LH100.2020.13	20	20	125	-	28.5	20	18.85	f ₁ +w/2	16.0	42	25.0	A	03
R/LH100.2020.23	20	20	125	-	33.5	20	18.85	f ₁ +w/2	21.0	42	25.0	A	03
R/LH100.2020.33	20	20	125	35.0	38.5	25	18.85	f ₁ +w/2	32.5	65	31.6	B	03
R/LH100.2525.13	25	25	150	-	28.5	25	23.85	f ₁ +w/2	16.0	42	30.0	A	03
R/LH100.2525.23	25	25	150	-	33.5	25	23.85	f ₁ +w/2	21.0	42	30.0	A	03
R/LH100.2525.33	25	25	150	-	38.5	25	23.85	f ₁ +w/2	32.5	65	31.6	B	03

State R or L version

w see inserts

Dimensions in mm

Further sizes upon request

Ordering note:

Wrench **P39L** is not combined with blade R/LH100...33 - separate order required!

For torque specification of the screw, please see Technical Instructions.

Spare Parts

Toolholder	Clamping Screw	TORX PLUS® Wrench	Wrench
R/LH100...	5.17T20P	T20PQ	
R/LH100...33			P39L

Toolholder

H100

Depth of groove up to
Width of groove

32.5 mm
3 mm

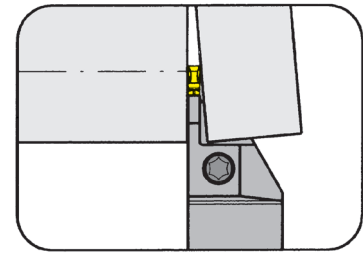

for Insert

Type S100

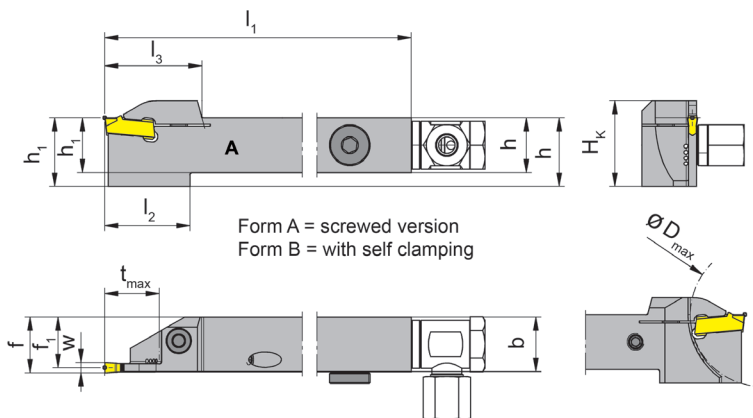

with through coolant supply

R = right hand version shown

L = left hand version

Part number	h	b	l ₁	l ₂	l ₃	h ₁	f ₁	f	t _{max}	D _{max}	H _K	Form	Size
R/LH100.1212.03.IK	12	12	125	21.0	23.0	16	10.85	f ₁ +w/2	13.0	26	25.0	A	03
R/LH100.1616.03.IK	16	16	125	19.5	23.0	20	14.85	f ₁ +w/2	10.5	42	25.0	A	03
R/LH100.1616.13.IK	16	16	125	25.0	28.5	20	14.85	f ₁ +w/2	16.0	42	25.0	A	03
R/LH100.2020.13.IK	20	20	125	-	28.5	20	18.85	f ₁ +w/2	16.0	42	25.0	A	03
R/LH100.2525.13.IK	25	25	150	-	28.5	25	23.85	f ₁ +w/2	16.0	42	30.0	A	03
R/LH100.1616.23.IK	16	16	125	30.0	33.5	20	14.85	f ₁ +w/2	21.0	42	25.0	A	03
R/LH100.2020.23.IK	20	20	125	-	33.5	20	18.85	f ₁ +w/2	21.0	42	25.0	A	03
RH100.2525.23.IK	25	25	150	-	33.5	25	23.85	f ₁ +w/2	21.0	42	30.0	A	03
R/LH100.2020.33.IK	20	20	125	35.0	38.5	25	18.85	f ₁ +w/2	32.5	65	31.6	B	03
R/LH100.2525.33.IK	25	25	150	-	38.5	25	23.85	f ₁ +w/2	32.5	65	31.6	B	03

State R or L version

w see inserts

Dimensions in mm

Further sizes upon request

Ordering note:

Wrench **P39L** is not combined with blade R/LH100...33 - separate order required!

Spare Parts

Toolholder	Clamping Screw	Coolant supply	TORX PLUS® Wrench	Sealing Plug	Threaded Pin	Screw	Wrench
R/LH100.1212.03.IK	5.17T20P	004.00.61	T20PQ				
R/LH100.1616.03.IK	5.17T20P	004.00.16	T20PQ	004.00.26	18.05.913		
R/LH100...13/.23.IK	5.17T20P	004.00.16	T20PQ	004.00.26	18.05.913		
R/LH100.2525.23.IK	5.17T20P	004.00.61	T20PQ		4.06.913	004.00.21	
R/LH100...33.IK		004.00.16		004.00.26	18.05.913		P39L

Toolholder

H100

with screwed clamping

Depth of groove up to
Width of groove

21.5 mm
3 - 4 mm

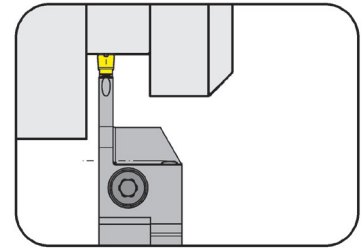

for Insert

Type S100

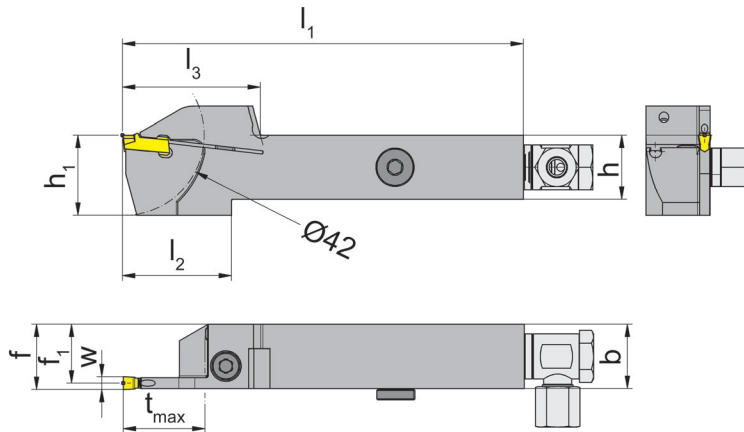

with through coolant supply

R = right hand version shown

L = left hand version

Part number	h	b	l ₁	l ₂	l ₃	h ₁	f ₁	f	t _{max}	Size
R/LH100.1616.0.23.IK	16	16	125	35	39	25	14.65	f ₁ +w/2	21.5	03
R/LH100.2020.0.23.IK	20	20	125	33	39	25	18.65	f ₁ +w/2	21.5	03
R/LH100.2525.0.23.IK	25	25	150	33	39	30	23.65	f ₁ +w/2	21.5	03
R/LH100.1616.0.24.IK	16	16	125	35	39	25	14.30	f ₁ +w/2	21.5	04
R/LH100.2020.0.24.IK	20	20	125	33	39	25	18.30	f ₁ +w/2	21.5	04
R/LH100.2525.0.24.IK	25	25	150	33	39	30	23.30	f ₁ +w/2	21.5	04

State R or L version

w see inserts

Dimensions in mm

Further sizes upon request

For torque specification of the screw, please see Technical Instructions.

Spare Parts

Toolholder	Sealing plug	Threaded Pin	Coolant supply	Clamping Screw	TORX PLUS® Wrench
R/LH100...23/24.IK	004.00.26	18.05.913	004.00.16	6.23T25P	T25PQ

Toolholder

H100

Depth of groove up to
Width of groove

40.5 mm
4 mm

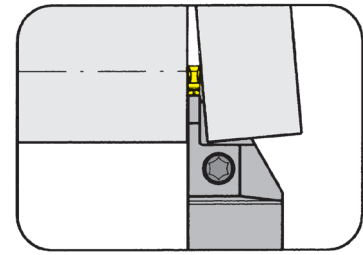

for Insert

Type S100

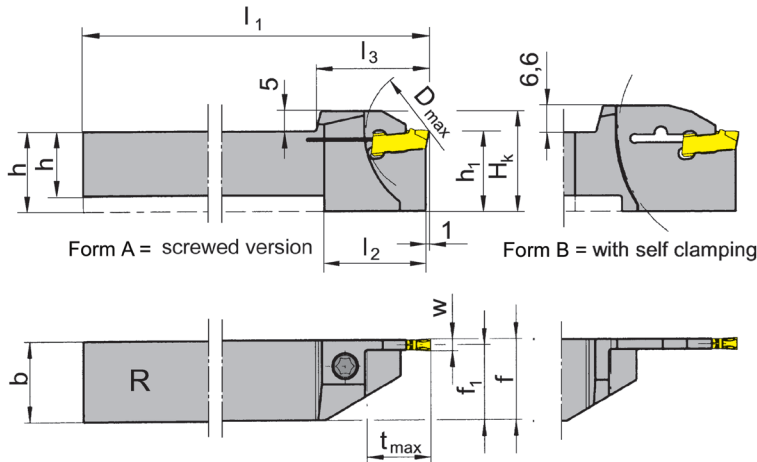

R = right hand version shown

L = left hand version

Part number	h	b	l ₁	l ₂	l ₃	h ₁	f ₁	f	t _{max}	D _{max}	H _K	Form	Size
R/LH100.1616.04	16	16	125	19.5	23.0	20	14.45	f ₁ +w/2	10.5	42	25.0	A	04
R/LH100.1616.14	16	16	125	25.0	28.5	20	14.45	f ₁ +w/2	16.0	42	25.0	A	04
R/LH100.1616.24	16	16	125	30.0	33.5	20	14.45	f ₁ +w/2	21.0	42	25.0	A	04
R/LH100.2020.14	20	20	125	-	28.5	20	18.45	f ₁ +w/2	16.0	42	25.0	A	04
R/LH100.2020.34	20	20	125	35.0	38.5	25	18.45	f ₁ +w/2	32.5	65	31.6	B	04
R/LH100.2525.14	25	25	150	-	28.5	25	23.45	f ₁ +w/2	16.0	42	30.0	A	04
R/LH100.2525.34	25	25	150	40.0	46.5	32	23.45	f ₁ +w/2	40.5	81	31.6	B	04

State R or L version

w see inserts

Dimensions in mm

Further sizes upon request

Wrench **P39L** is not combined with blade R/LH100...34 - separate order required!

For torque specification of the screw, please see Technical Instructions.

Spare Parts

Toolholder	Clamping Screw	TORX PLUS® Wrench	Wrench
R/LH100...04/.14/.24	5.17T20P	T20PQ	
R/LH100...34			P39L

Toolholder

H100

Depth of groove up to
Width of groove

40.5 mm
5 mm

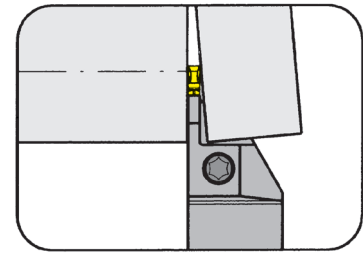

for Insert

Type S100

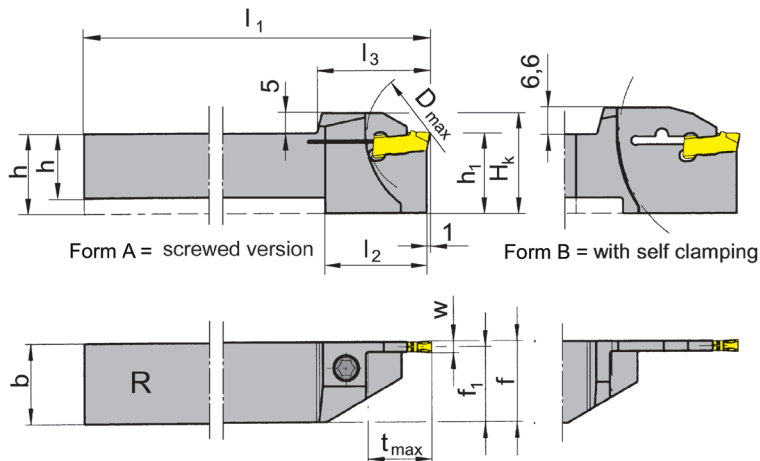

R = right hand version shown

L = left hand version

Part number	h	b	l ₁	l ₂	l ₃	h ₁	f ₁	f	t _{max}	D _{max}	H _K	Form	Size
R/LH100.2020.15	20	20	125	-	28.5	20	18.05	$f_1 + w/2$	16.0	42	25.0	A	05
R/LH100.2020.35	20	20	125	35	38.5	25	18.05	$f_1 + w/2$	32.5	65	31.6	B	05
R/LH100.2525.15	25	25	150	-	28.5	25	23.05	$f_1 + w/2$	16.0	42	30.0	A	05
R/LH100.2525.35	25	25	150	40	46.5	32	23.05	$f_1 + w/2$	40.5	81	38.6	B	05

State R or L version

w see inserts

Dimensions in mm

Further sizes upon request

Wrench **P39L** is not combined with blade R/LH100...35 - separate order required!

For torque specification of the screw, please see Technical Instructions.

Spare Parts

Toolholder	Clamping Screw	TORX PLUS® Wrench	Wrench
R/LH100...15	5.17T20P	T20PQ	
R/LH100...35			P39L

Toolholder

H100

Depth of groove up to
Width of groove

41 mm
4 - 12 mm

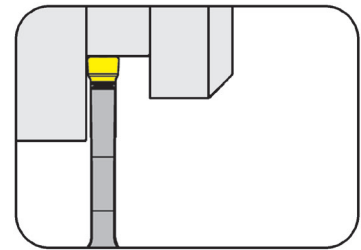

for Insert

Type S100

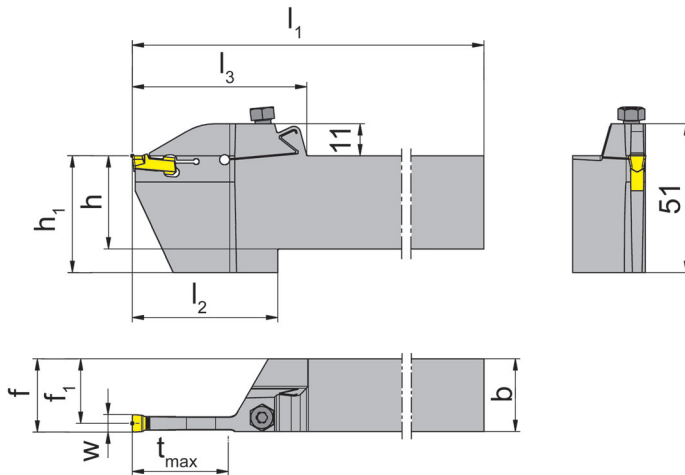

R = right hand version shown

L = left hand version

Part number	h	b	l ₁	l ₂	l ₃	h ₁	f ₁	f	t _{max}	Size
R/LH100.2020.3.04	20	20	150	50	60	32	18.2	f ₁ +w/2	33	04
R/LH100.2020.3.05	20	20	150	50	60	32	17.7	f ₁ +w/2	33	05
R/LH100.2525.3.05	25	25	150	50	60	32	22.7	f ₁ +w/2	33	05
R/LH100.2525.3.06	25	25	150	50	60	40	22.2	f ₁ +w/2	33	06
R/LH100.3225.3.06	32	25	170	50	60	40	22.2	f ₁ +w/2	33	06
R/LH100.3225.3.08	32	25	170	50	60	40	21.2	f ₁ +w/2	33	08
R/LH100.3225.3.8	32	25	170	50	60	40	21.2	f ₁ +w/2	35	08
R/LH100.3225.4.08	32	25	170	55	65	40	21.2	f ₁ +w/2	41	08
R/LH100.3225.4.10	32	25	170	55	65	40	20.3	f ₁ +w/2	41	10
R/LH100.3225.4.12	32	25	170	55	65	40	19.3	f ₁ +w/2	41	12

State R or L version

w see inserts

Dimensions in mm

Further sizes upon request

For torque specification of the screw, please see Technical Instructions.

Spare Parts

Toolholder	Clamping Screw	TORX PLUS® Wrench
R/LH100...	030.6075.T20P	T20PQ



Toolholder

H100

with screwed clamping

Depth of groove up to
Width of groove

33 mm
4 mm

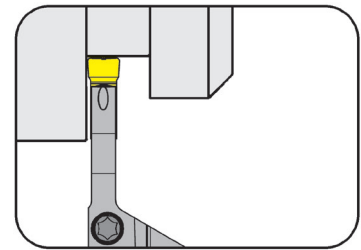

for Insert

Type S100

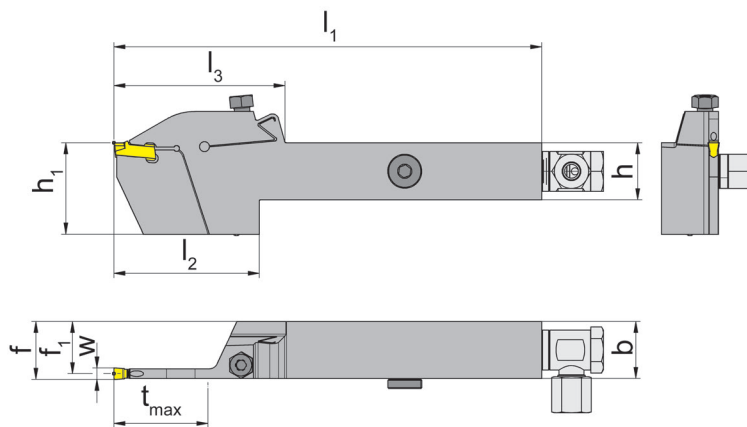

R = right hand version shown

L = left hand version

with through coolant supply

Part number	h	b	l_1	l_2	l_3	h_1	f_1	f	t_{max}	Size
R/LH100.2020.3.0.04.IK	20	20	150	51	60	32	18.3	$f_1 + w/2$	33	04
R/LH100.2525.3.0.04.IK	25	25	150	50	60	32	23.3	$f_1 + w/2$	33	04

State R or L version

w see inserts

Dimensions in mm

Further sizes upon request

Spare Parts

Toolholder	Sealing plug	Threaded Pin	Coolant supply	Clamping Screw	TORX PLUS® Wrench
R/LH100...	004.00.26	18.05.913	004.00.16	030.6075.T20P	T20PQ

Toolholder

H100

Depth of groove up to 45 mm
Width of groove 16 mm

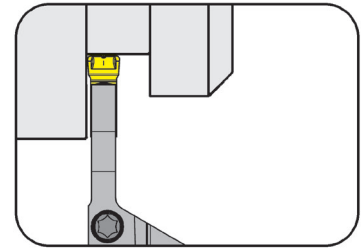

for Insert

Type S100

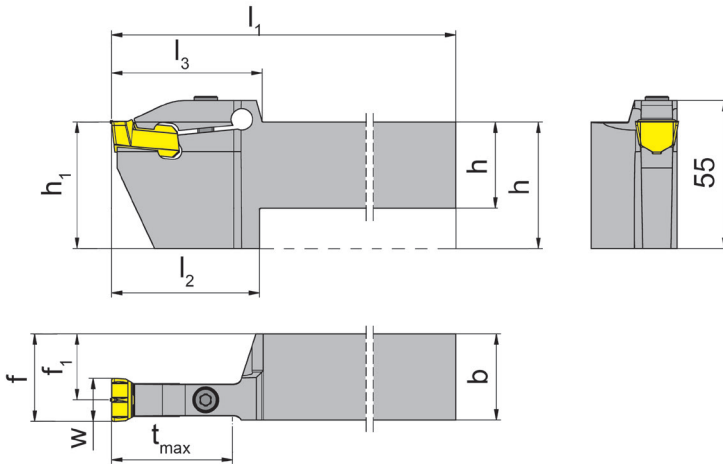

R = right hand version shown

L = left hand version

Part number	h	b	l ₁	l ₂	h ₁	f ₁	f	t _{max}	l ₃	Size
R/LH100.3232.5.16	32	32	170	55	47	24.5	f ₁ +w/2	45	56	16

State R or L version

w see inserts

Dimensions in mm

Further sizes upon request

For torque specification of the screw, please see Technical Instructions.

Spare Parts

Toolholder	Clamping Screw	TORX PLUS® Wrench	Washer
R/LH100.3232.5.16	030.0625.T25P	T25PQ	020.0006.3526



Toolholder

H100

Depth of groove up to
Width of groove

25 mm
3 - 4 mm

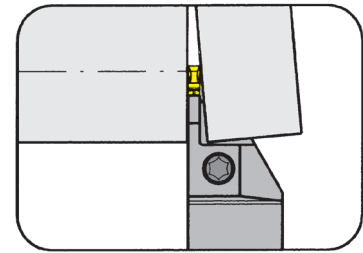

for Insert

Type S100

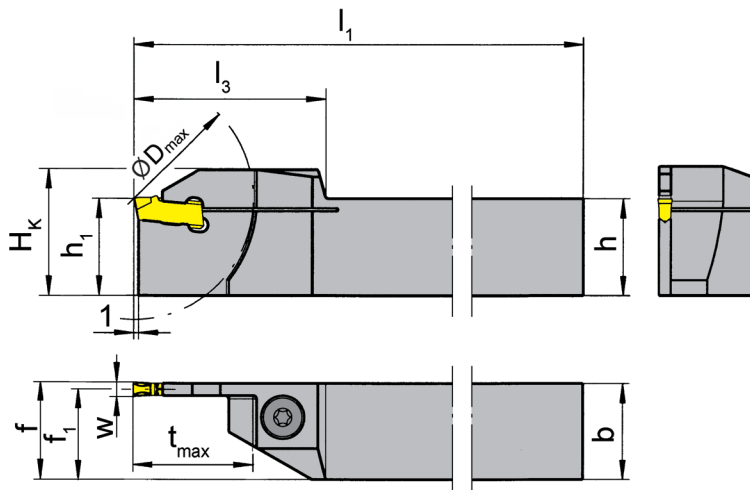

L = left hand version shown

R = right hand version

Part number	h	b	l ₁	l ₃	h ₁	f ₁	f	t _{max}	D _{max}	H _K	Size
R/LH100.2020.73	20	20	125	40	20	18.85	f ₁ +w/2	25	50	26	03
R/LH100.2525.73	25	25	150	40	25	23.85	f ₁ +w/2	25	50	31	03
R/LH100.2020.74	20	20	125	40	20	18.85	f ₁ +w/2	25	50	26	04

State R or L version

w see inserts

Dimensions in mm

Further sizes upon request

For torque specification of the screw, please see Technical Instructions.

Spare Parts

Toolholder	Clamping Screw	TORX PLUS® Wrench
R/LH100...	6.23T25P	T25PQ

Toolholder

H100

with screwed clamping

Depth of groove up to
Width of groove

25.5 mm
3 - 4 mm

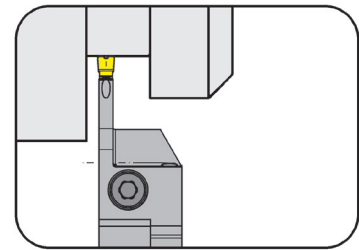

for Insert

Type S100

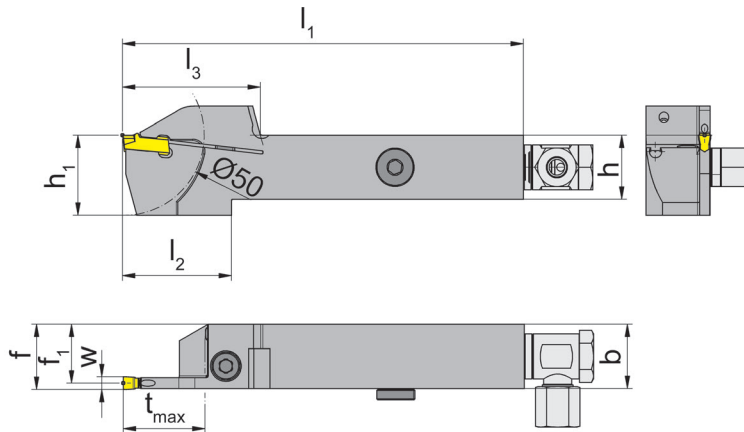

R = right hand version shown

L = left hand version

with through coolant supply

Part number	h	b	l_1	l_2	l_3	h_1	f_1	f	t_{max}	Size
R/LH100.2020.0.73.IK	20	20	125	37	43	25	18.65	$f_1+w/2$	25.5	03
R/LH100.2525.0.73.IK	25	25	150	37	43	30	23.65	$f_1+w/2$	25.5	03
R/LH100.2525.0.74.IK	25	25	150	37	43	30	23.30	$f_1+w/2$	25.5	04
R/LH100.2020.0.74.IK	20	20	125	37	43	25	18.30	$f_1+w/2$	25.5	04

State R or L version

w see inserts

Dimensions in mm

Further sizes upon request

For torque specification of the screw, please see Technical Instructions.

Spare Parts

Toolholder	Sealing plug	Threaded Pin	Coolant supply	Clamping Screw	TORX PLUS® Wrench
R/LH100...73/.74.IK	004.00.26	18.05.913	004.00.16	6.23T25P	T25PQ



Toolholder

H100

with screwed clamping

Depth of groove up to
Width of groove

34 mm
3 - 4 mm

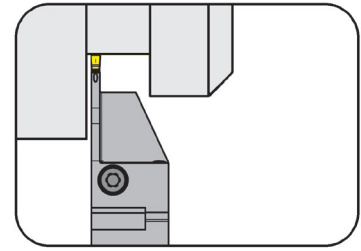

for Insert

Type S100

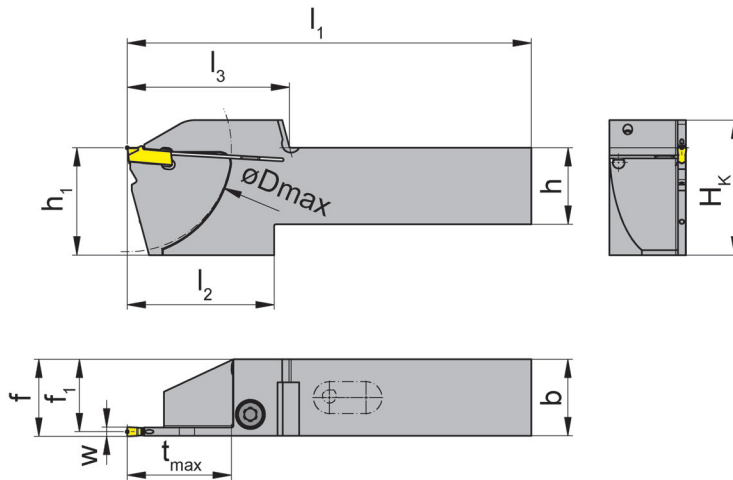

R = right hand version shown

L = left hand version

with integrated through
coolant supply

Part number	h	b	l ₁	l ₂	l ₃	h ₁	f ₁	f	t _{max}	D _{max}	H _k	Size
R/LH100.2020.34.4.73.IK	20	20	115	48	53	30	18.65	f ₁ +w/2	34	68	39	03
R/LH100.2525.34.4.73.IK	25	25	132	48	53	35	23.65	f ₁ +w/2	34	68	44	03

State R or L version

w see inserts

Dimensions in mm

Further sizes upon request

For torque specification of the screw, please see Technical Instructions.

Spare Parts

Toolholder	O - ring	Clamping Screw	TORX PLUS® Wrench
R/LH100...	12.37.2.62.3601	6.23T25P	T25PQ

Toolholder

H100

Depth of groove up to 41 mm
Width of groove 3 - 4 mm

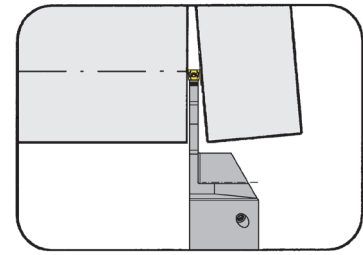

for Insert

Type S100

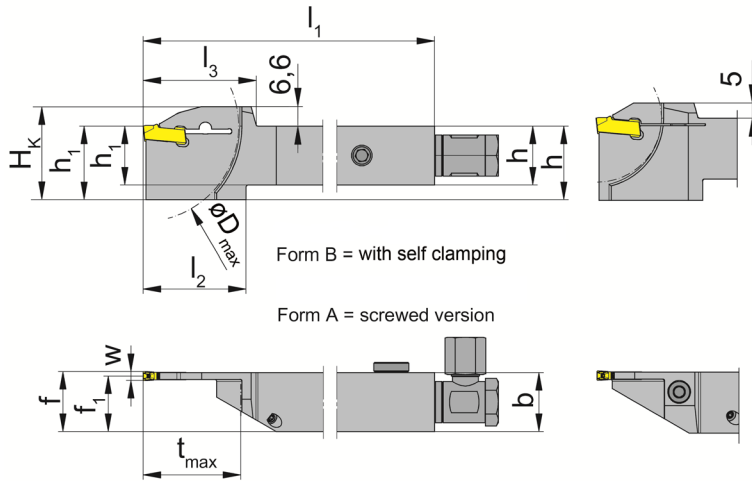

L = left hand version shown

R = right hand version

Coolant supply through insert

Part number	h	b	l ₁	l ₂	l ₃	h ₁	f ₁	f	t _{max}	D _{max}	H _K	Form	Size
R/LH100.1616.1.23.IK	16	16	125	35	33.5	27	14.85	f ₁ +w/2	21.5	42	32.0	A	03
R/LH100.2020.1.13.IK	20	20	125	30	28.5	27	18.85	f ₁ +w/2	16.0	42	32.0	A	03
R/LH100.2020.1.23.IK	20	20	125	35	33.5	27	18.85	f ₁ +w/2	21.5	42	32.0	A	03
R/LH100.2020.1.33.IK	20	20	125	35	38.5	27	18.85	f ₁ +w/2	33.0	65	33.6	B	03
R/LH100.2525.1.33.IK	25	25	150	35	38.5	32	23.85	f ₁ +w/2	33.0	65	38.6	B	03
R/LH100.2020.1.34.IK	20	20	125	35	38.5	27	18.45	f ₁ +w/2	33.0	65	33.6	B	04
R/LH100.2525.1.34.IK	25	25	150	40	46.5	32	23.45	f ₁ +w/2	41.0	81	38.6	B	04

State R or L version

w see inserts

Dimensions in mm

Further sizes upon request

Ordering note:

Wrench **P39L** is not combined with blade R/LH100...33 or blade R/LH100...34 - separate order required!

For torque specification of the screw, please see Technical Instructions.

Spare Parts

Toolholder	Clamping Screw	Sealing plug	Threaded Pin	Coolant supply	TORX PLUS® Wrench	Wrench
R/LH100...1.13/.23.IK	5.17T20P	004.00.26	18.05.913	004.00.16	T20PQ	
R/LH100...1.33/.34.IK		004.00.26	18.05.913	004.00.16		P39L

Toolholder

H100

with screwed clamping

Depth of groove up to
Width of groove

21.5 mm
2.5 mm

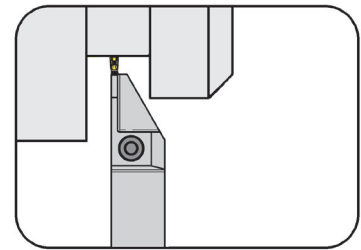

for Insert

Type S100
S100...IK

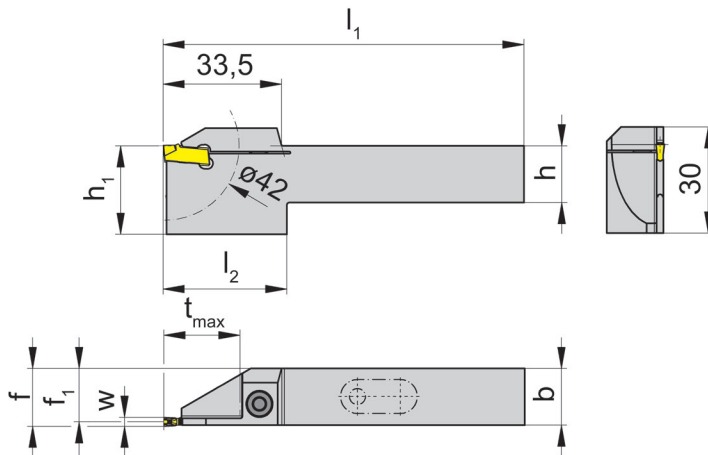

R = right hand version shown

L = left hand version

Coolant supply through
insert

Part number	h	b	l_1	l_2	h_1	f_1	f	t_{max}	Size
R/LH100.1616.3.22.IK	16	16	89	35	25	15.05	$f_1 + w/2$	21.5	02
R/LH100.2020.3.22.IK	20	20	102	35	25	19.05	$f_1 + w/2$	21.5	02

State R or L version

w see inserts

Dimensions in mm

Further sizes upon request

For torque specification of the screw, please see Technical Instructions.

Spare Parts

Toolholder	Clamping Screw	O - ring	TORX PLUS® Wrench
R/LH100...	5.17T20P	12.37.2.62.3601	T20PQ

Toolholder

H100

with self clamping

Depth of groove up to
Width of groove

33 mm
3 mm

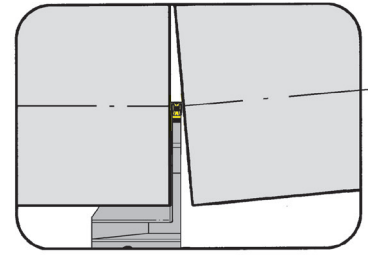

for Insert

Type S100
S100...IK

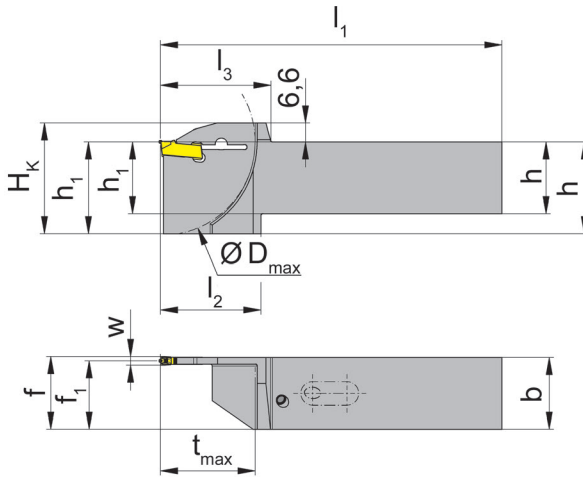

L = left hand version shown

R = right hand version

Coolant supply through
insert

Part number	h	b	l ₁	l ₂	l ₃	h ₁	f ₁	f	t _{max}	D _{max}	H _k	Size
R/LH100.2020.3.33.IK	20	20	104	35	38.5	27	18.85	f ₁ +w/2	33	65	33.6	03
R/LH100.2525.3.33.IK	25	25	119	35	38.5	32	23.85	f ₁ +w/2	33	65	38.6	03

State R or L version

w see inserts

Dimensions in mm

Further sizes upon request

Ordering note:

Wrench **P39L** is not combined with blade R/LH100...33 - separate order required!

Spare Parts

Toolholder	O-ring	Wrench
R/LH100...3.33.IK	12.37.2.62.3601	P39L



Coolant Output Options

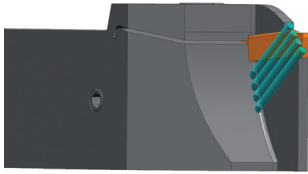

Coolant outlet through spray nozzle at the side of the insert.

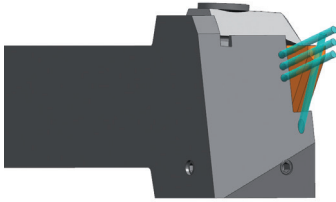

Coolant outlet through spray nozzle at the side of the insert.

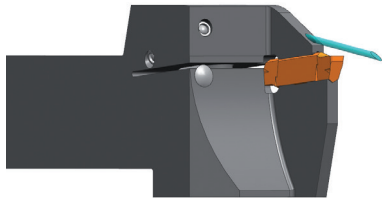

S100
S224
S229

Coolant outlet through clamping finger.

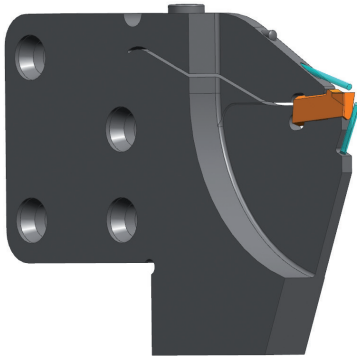

S100
S224
S229

Coolant outlet through clamping finger and insert support.

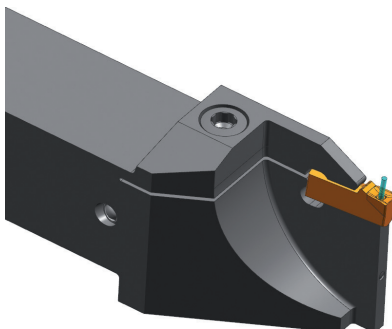

S100
S224

Coolant outlet through insert.

U



U

Toolholder

H223

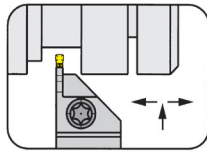

Page
U44 - U46

Insert

S123

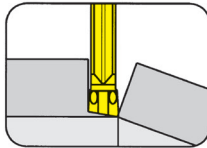

Page
U47 - U48

Indexable insert

S223

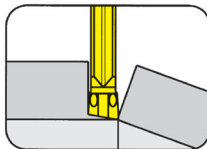

Page
U49 - U50

123/223

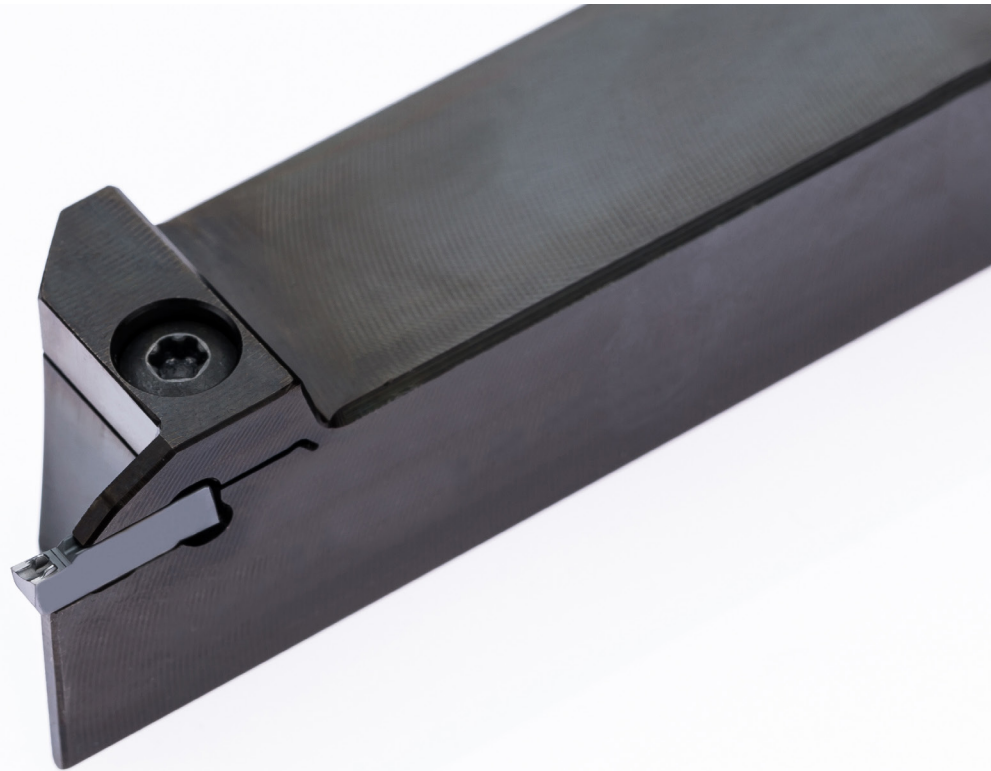

U

Toolholder with Inserts

Chip forming Width of groove .079 - .118"

Depth of groove up to .984"

Toolholder

HU223

Depth of groove up to
Clamping range

.394"
.079 - .118"

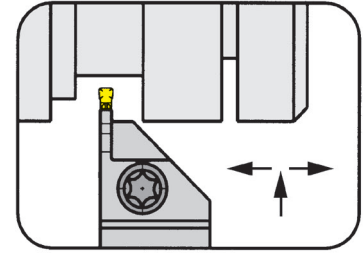

for Insert

Type S123
S223

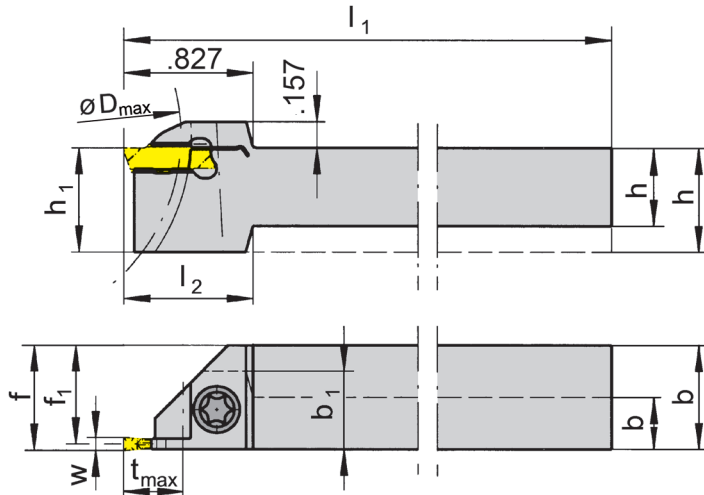

R = right hand version shown

L = left hand version

Part number	h	b	l ₁	l ₂	h ₁	b ₁	f	t _{max}	D _{max}	Size	Clamping range
R/LHU223.0375.01	.375	.375	3.150	.787	.472	.453	f ₁ +w/2	.315	.984	01	.079
R/LHU223.0500.01	.500	.500	3.996	.827	.500	-	f ₁ +w/2	.394	1.969	01	.079
R/LHU223.0625.01	.625	.625	5.118	.827	.625	-	f ₁ +w/2	.394	1.969	01	.079
R/LHU223.0750.01	.750	.750	5.118	.827	.750	-	f ₁ +w/2	.394	1.969	01	.079
R/LHU223.1000.01	1.000	1.000	6.004	.827	1.000	-	f ₁ +w/2	.394	1.969	01	.079
R/LHU223.0375.02	.375	.375	3.150	.787	.472	.453	f ₁ +w/2	.315	.984	02	.098
R/LHU223.0500.02	.500	.500	3.996	-	.500	-	f ₁ +w/2	.394	1.969	02	.098
R/LHU223.0625.02	.625	.625	5.118	-	.625	-	f ₁ +w/2	.394	1.969	02	.098
R/LHU223.0750.02	.750	.750	5.118	.827	.750	-	f ₁ +w/2	.394	1.969	02	.098
R/LHU223.1000.02	1.000	1.000	6.004	.827	1.000	-	f ₁ +w/2	.394	1.969	02	.098
R/LHU223.0500.03	.500	.500	3.996	.827	.500	-	f ₁ +w/2	.394	1.969	03	.118
R/LHU223.0625.03	.625	.625	5.118	.827	.625	-	f ₁ +w/2	.394	1.969	03	.118
R/LHU223.0750.03	.750	.750	5.118	.827	.750	-	f ₁ +w/2	.394	1.969	03	.118
R/LHU223.1000.03	1.000	1.000	6.004	-	1.000	-	f ₁ +w/2	.394	1.969	03	.118

State R or L version

w see indexable inserts

Dimensions in inch

Further sizes upon request

For torque specification of the screw, please see Technical Instructions.

Spare Parts

Toolholder	Clamping Screw	TORX PLUS® Wrench
R/LHU223...	5.11T15P	T15PL

Toolholder

H223

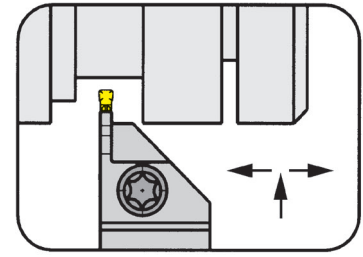

Depth of groove up to 10.0 mm
Width of groove 2 - 3 mm

for Insert

Type S123
S223

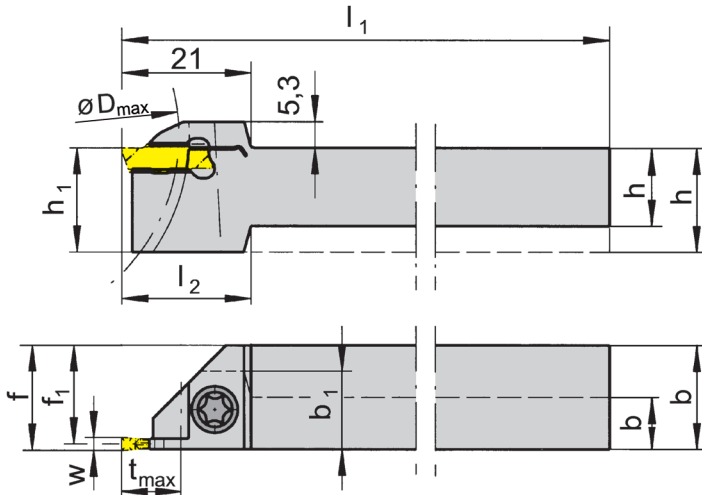

R = right hand version shown

L = left hand version

Part number	h	b	l ₁	l ₂	h ₁	b ₁	f ₁	f	t _{max}	D _{max}	Size	Clamping range
R/LH223.1010.01	10	10	80	20	12	12	9.2	f ₁ +w/2	8	25	01	2
R/LH223.1212.01	12	12	100	21	16	-	11.2	f ₁ +w/2	10	50	01	2
R/LH223.1616.01	16	16	125	-	16	-	15.2	f ₁ +w/2	10	50	01	2
R/LH223.2020.01	20	20	125	-	20	-	19.2	f ₁ +w/2	10	50	01	2
R/LH223.2525.01	25	25	150	-	25	-	24.2	f ₁ +w/2	10	50	01	2
R/LH223.1010.02	10	10	80	20	12	12	9	f ₁ +w/2	8	25	02	2.5
R/LH223.1212.02	12	12	100	21	16	-	11	f ₁ +w/2	10	50	02	2.5
R/LH223.1616.02	16	16	125	-	16	-	15.1	f ₁ +w/2	10	50	02	2.5
R/LH223.2020.02	20	20	125	-	20	-	19.05	f ₁ +w/2	10	50	02	2.5
R/LH223.2525.02	25	25	150	-	25	-	24	f ₁ +w/2	10	50	02	2.5
R/LH223.1010.03	10	10	80	20	12	12	8.8	f ₁ +w/2	8	25	03	3
R/LH223.1212.03	12	12	100	21	16	-	10.8	f ₁ +w/2	10	50	03	3
R/LH223.1616.03	16	16	125	-	16	-	14.8	f ₁ +w/2	10	50	03	3
R/LH223.2020.03	20	20	125	-	20	-	18.8	f ₁ +w/2	10	50	03	3
R/LH223.2525.03	25	25	150	-	25	-	23.8	f ₁ +w/2	10	50	03	3

State R or L version

w see indexable inserts

Dimensions in mm

Further sizes upon request

For torque specification of the screw, please see Technical Instructions.

Spare Parts

Toolholder	Clamping Screw	TORX PLUS® Wrench
R/LH223...	5.11T15P	T15PL



Toolholder

H223

reinforced version

Depth of groove up to
Clamping range

25 mm
2 - 3 mm

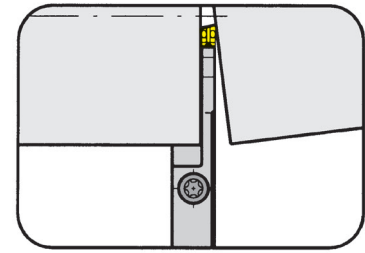

for Insert

Type S123
S223

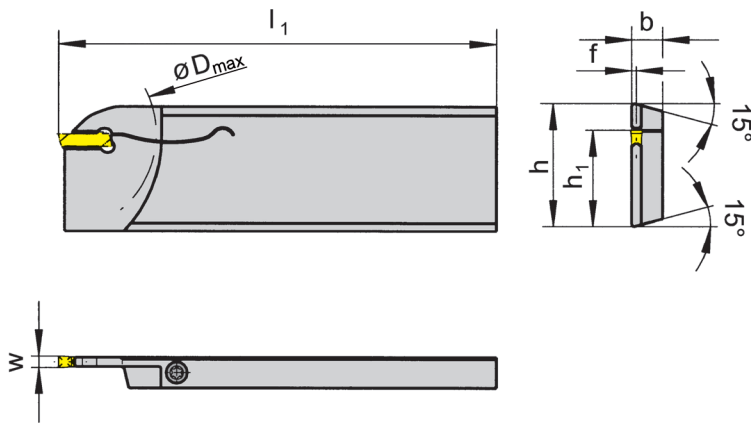

R = right hand version shown

L = left hand version

Part number	h	b	l ₁	h ₁	f	D _{max}	Size	Clamping range
R/LH223.2608.01	26	7.9	110	21.4	.80	50	01	2.0
R/LH223.3208.01	32	7.9	110	24.8	.80	50	01	2.0
R/LH223.2608.02	26	7.9	110	21.4	.95	50	02	2.5
R/LH223.3208.02	32	7.9	110	24.8	.95	50	02	2.5
R/LH223.2608.03	26	7.9	110	21.4	1.20	50	03	3.0
R/LH223.3208.03	32	7.9	110	24.8	1.20	50	03	3.0

State R or L version

w see indexable inserts

Dimensions in mm

Further sizes upon request

For torque specification of the screw, please see Technical Instructions.

Parting off:

Solid bars or tube (S223)

Solid bars (S123)

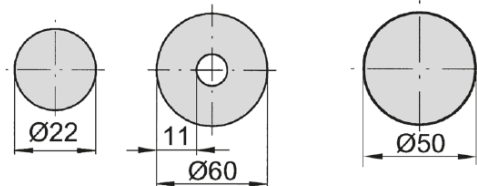

Spare Parts

Toolholder	Clamping Screw	TORX PLUS® Wrench
R/LH223...	4.15T15P	T15PL

Insert

S123

Depth of groove up to .984"
Width of groove .079 - .118"

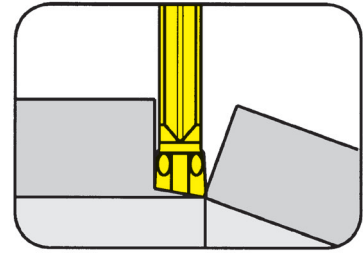

for Toolholder

Type H223
HU223

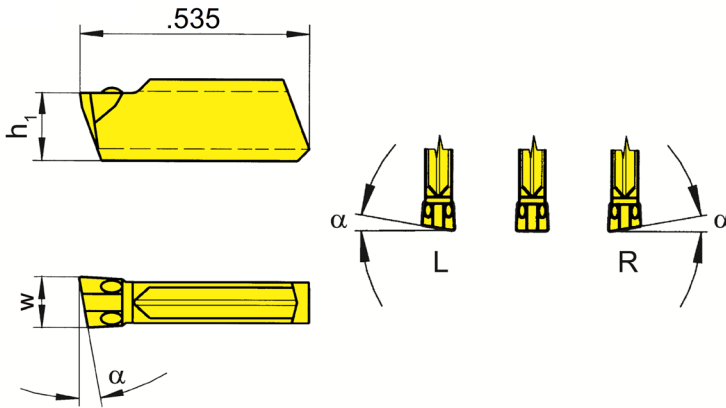

R = right hand version shown

L = left hand version

Part number	w	α	h ₁	Size	TF45	TI25	TN35
S123.0020.C0	.079	0°	.144	01	Δ	x	Δ
R/LS123.0420.C0	.079	4°	.144	01	x/x	x/x	x/x
R/LS123.0820.C0	.079	8°	.144	01	x/x	x/▲	Δ/x
R/LS123.1520.C0	.079	15°	.144	01	▲/x	x/▲	Δ/x
S123.0030.C0	.118	0°	.156	03	x	x	Δ
R/LS123.0430.C0	.118	4°	.156	03	x/x	x/x	x/x
R/LS123.0830.C0	.118	8°	.156	03	x/x	x/x	x/x

▲ on stock Δ 4 weeks x upon request

● recommended

o alternative recommendation

- not suitable

□ uncoated grades

■ coated grades

■ brazed/Cermet

Dimensions in inch

	P	M	K	N	S	H
TF45	●	●	●	●	●	●
TI25	●	●	●	●	●	●
TN35	●	●	●	●	●	●

Carbide grades

State R or L version

Indexable inserts can be used in **right and left** hand toolholders.

Insert

S123

Depth of groove up to .984"
Width of groove .079 - .118"

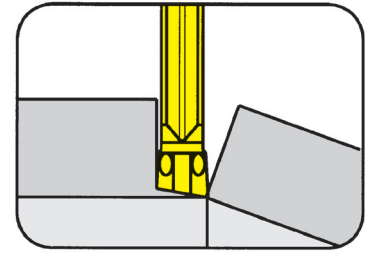

for Toolholder

Type H223
HU223

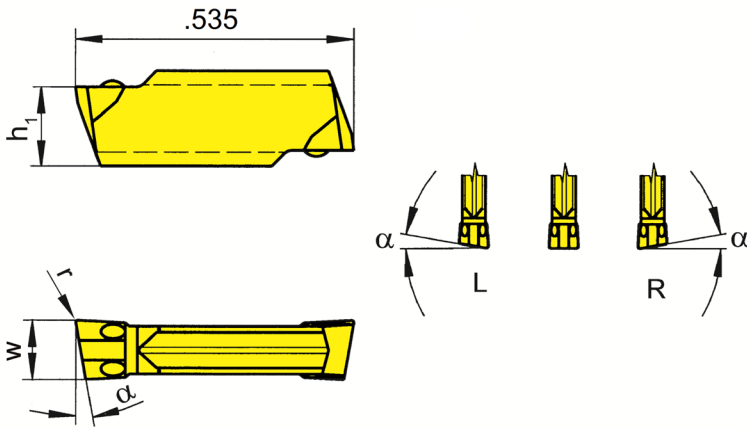

R = right hand version shown

L = left hand version

Part number	w	r	α	h ₁	Size	TF45	TI25	TN35
S123.0020.C1	.079	.006	0°	.144	01	Δ	Δ	Δ
R/LS123.0420.C1	.079	.006	4°	.144	01	Δ/Δ	Δ/Δ	Δ/Δ
R/LS123.0820.C1	.079	.006	8°	.144	01	Δ/Δ	Δ/Δ	Δ/Δ
R/LS123.1520.C1	.079	.006	15°	.144	01	Δ/Δ	Δ/Δ	Δ/Δ
S123.0030.C1	.118	.006	0°	.156	03	Δ	Δ	Δ
R/LS123.0430.C1	.118	.006	4°	.156	03	Δ/Δ	Δ/Δ	Δ/Δ
R/LS123.0830.C1	.118	.006	8°	.156	03	Δ/Δ	Δ/Δ	Δ/Δ

▲ on stock Δ 4 weeks x upon request

● recommended

○ alternative recommendation

- not suitable

□ uncoated grades

■ coated grades

■ brazed/Cermet

Dimensions in inch

State R or L version

Indexable inserts can be used in **right and left** hand toolholders.

	P	M	K	N	S	H
TF45	●	●	●	●	●	●
TI25	●	●	●	●	●	●
TN35	●	●	●	●	●	●
Carbide grades	-	-	-	-	-	-

Indexable insert

S223

Depth of groove up to
Width of groove

.433"
.079 - .118"

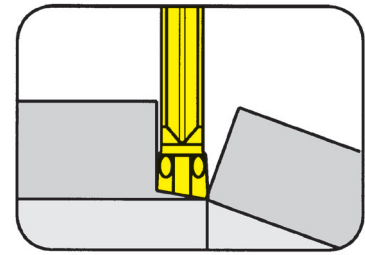

for Toolholder

Type H223
HU223

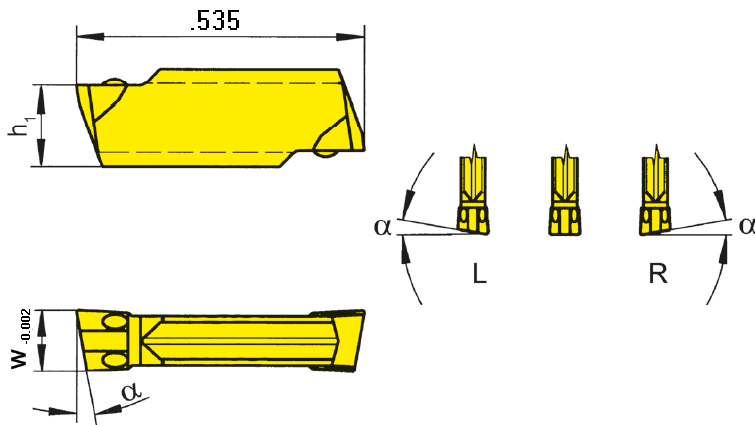

R = right hand version shown

L = left hand version

Part number	w	α	h ₁	Size	TF45	TI25	TN35
S223.0020.C0	.079	0°	.144	01	▲	▲	▲
R/LS223.0420.C0	.079	4°	.144	01	x/▲	▲/▲	▲/▲
R/LS223.0820.C0	.079	8°	.144	01	▲/Δ	▲/▲	▲/▲
R/LS223.1520.C0	.079	15°	.144	01	▲/x	▲/▲	▲/▲
S223.0025.C0	.098	0°	.148	02	x	▲	x
R/LS223.0425.C0	.098	4°	.148	02	x/x	▲/x	▲/Δ
R/LS223.0825.C0	.098	8°	.148	02	▲/x	▲/x	▲/Δ
S223.0030.C0	.118	0°	.156	03	Δ	▲	▲
R/LS223.0430.C0	.118	4°	.156	03	x/x	x/x	Δ/Δ
R/LS223.0830.C0	.118	8°	.156	03	Δ/x	▲/▲	▲/▲
					P	•	•
					M	•	•
					K	•	•
					N	•	•
					S	•	•
					H	-	-

▲ on stock Δ 4 weeks x upon request

● recommended

o alternative recommendation

- not suitable

■ uncoated grades

■ coated grades

■ brazed/Cermet

Dimensions in inch

State R or L version

Indexable inserts can be used in right and left hand toolholders.

Carbide grades



Indexable insert

S223

Depth of groove up to .433"
Width of groove .079 - .118"

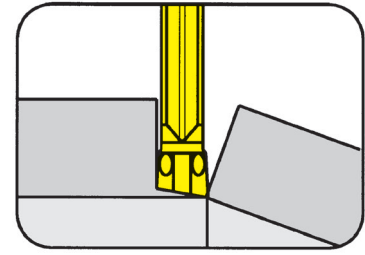

for Toolholder

Type H223
HU223

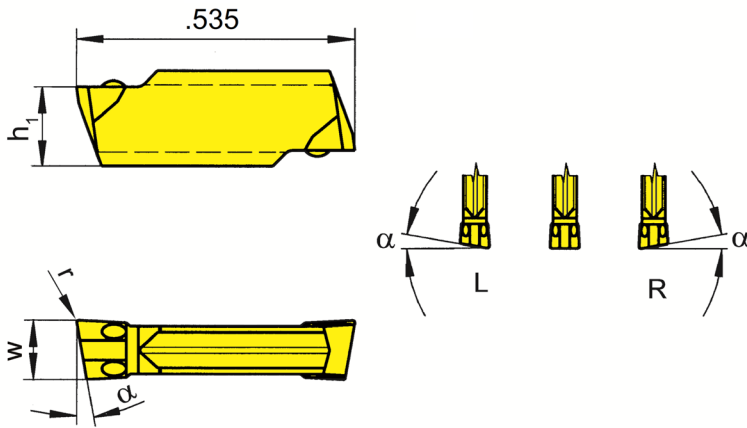

R = right hand version shown

L = left hand version

Part number	w	r	α	h ₁	Size	TF45	TI25	TN35
S223.0020.C1	.079	.006	0°	.144	01	▲	▲	▲
R/LS223.0420.C1	.079	.006	4°	.144	01	▲/x	Δ/x	▲/Δ
R/LS223.0820.C1	.079	.006	8°	.144	01	Δ/x	▲/x	▲/▲
R/LS223.1520.C1	.079	.006	15°	.144	01	▲/▲	▲/▲	▲/▲
S223.0025.C1	.098	.006	0°	.148	02	▲	▲	▲
R/LS223.0425.C1	.098	.006	4°	.148	02	x/x	▲/x	x/Δ
R/LS223.0825.C1	.098	.006	8°	.148	02	▲/x	▲/x	x/x
S223.0030.C1	.118	.006	0°	.156	03	▲	▲	▲
R/LS223.0430.C1	.118	.006	4°	.156	03	x/x	x/x	Δ/Δ
R/LS223.0830.C1	.118	.006	8°	.156	03	▲/x	▲/x	▲/x
						P	•	•
						M	•	•
						K	•	•
						N	•	•
						S	•	•
						H	-	-

▲ on stock Δ 4 weeks x upon request
● recommended
o alternative recommendation
- not suitable
■ uncoated grades
■ coated grades
■ brazed/Cermet

Carbide grades	TF45	TI25	TN35
P	•	•	•
M	•	•	•
K	•	•	•
N	•	•	•
S	•	•	•
H	-	-	-

Dimensions in inch

State R or L version

Indexable inserts can be used in right and left hand toolholders.

Indexable insert

S223

Depth of groove up to .433"
Width of groove .079 - .118"

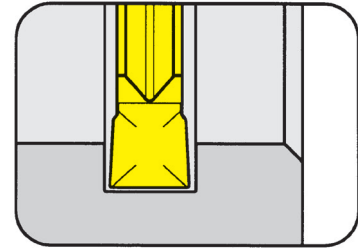

for Toolholder

Type H223
HU223

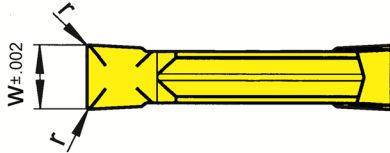
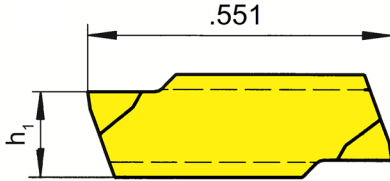

Part number	w	r	h ₁	Size	Carbide grades			
					MG12	H54	TI25	TN35
S223.0200.32	.079	.008	.144	01	▲	▲	▲	▲
S223.0250.32	.098	.008	.148	02	▲	▲	▲	▲
S223.0300.32	.118	.008	.156	03	▲	▲	▲	▲
					P	○	●	●
					M	-	●	●
					K	-	-	●
					N	-	-	●
					S	-	-	●
					H	-	-	-

▲ on stock Δ 4 weeks x upon request

● recommended
○ alternative recommendation
- not suitable

□ uncoated grades
■ coated grades
■ brazed/Cermet

Dimensions in inch

Carbide grades

Indexable inserts can be used in right and left hand toolholders.



Toolholder
H224

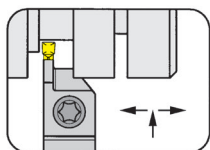

Page
U54 - U62

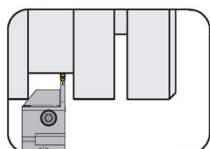

Page
U67

Indexable insert
S224

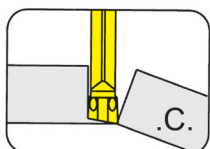

Page
U65-U66

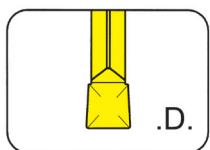

Page
U67

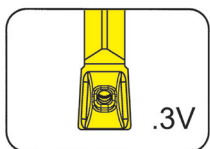

Page
U70

U

S224

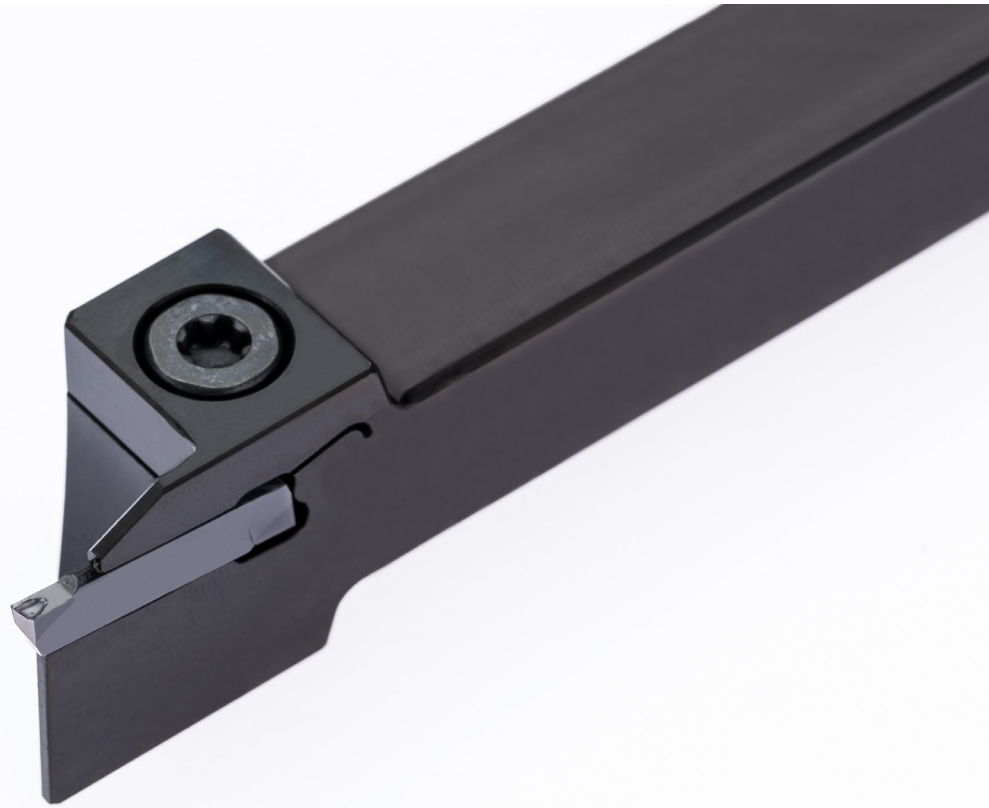

Toolholder with Inserts

Width of groove .079 - .118"

U

Toolholder

HU224

Depth of groove up to .551"
Clamping range .146"

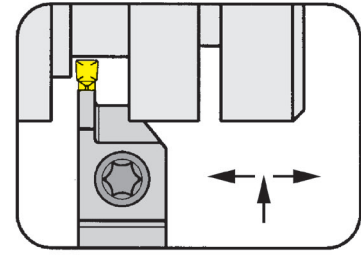

for Indexable insert

Type S224
NS224

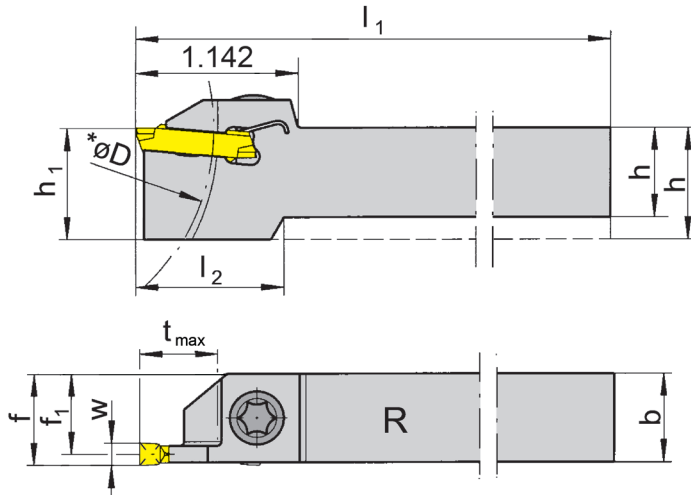

R = right hand version shown

L = left hand version

Part number	h	b	l ₁	l ₂	h ₁	f ₁	f	t _{max}	D _{max}	Size	Clamping range
R/LHU224.0625.01	.625	.625	5.118	.984	.787	.597	f ₁ +w/2	.551	3.15	01	.079 - .094
R/LHU224.0750.01	.750	.750	5.118	-	.750	.722	f ₁ +w/2	.551	3.15	01	.079 - .094
R/LHU224.1000.01	1.000	1.000	6.004	-	1.000	.972	f ₁ +w/2	.551	3.15	01	.079 - .094
R/LHU224.0625.02	.625	.625	5.118	.984	.787	.589	f ₁ +w/2	.551	3.15	02	.094 - .110
R/LHU224.0750.02	.750	.750	5.118	-	.750	.715	f ₁ +w/2	.551	3.15	02	.094 - .110
R/LHU224.1000.02	1.000	1.000	6.004	-	1.000	.965	f ₁ +w/2	.551	3.15	02	.094 - .110
R/LHU224.0625.03	.625	.625	4.921	.984	.787	.581	f ₁ +w/2	.551	3.15	03	.110 - .146
R/LHU224.0750.03	.750	.750	5.118	-	.750	.707	f ₁ +w/2	.551	3.15	03	.110 - .146
R/LHU224.1000.03	1.000	1.000	6.004	-	1.000	.957	f ₁ +w/2	.551	3.15	03	.110 - .146

State R or L version

w see indexable inserts

Dimensions in inch

Further sizes upon request

* t_{max} up to D = 3.150"

For torque specification of the screw, please see Technical Instructions.

Spare Parts

Toolholder	Clamping Screw	TORX PLUS® Wrench
R/LHU224...	6.23T25P	T25PQ

Toolholder

H224

Depth of groove up to
Clamping range

14 mm
2 - 3.7 mm

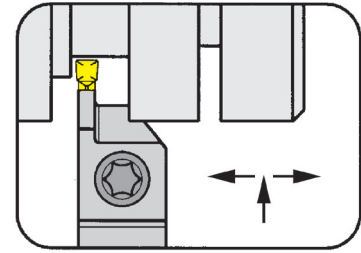

for Indexable insert

Type S224
NS224

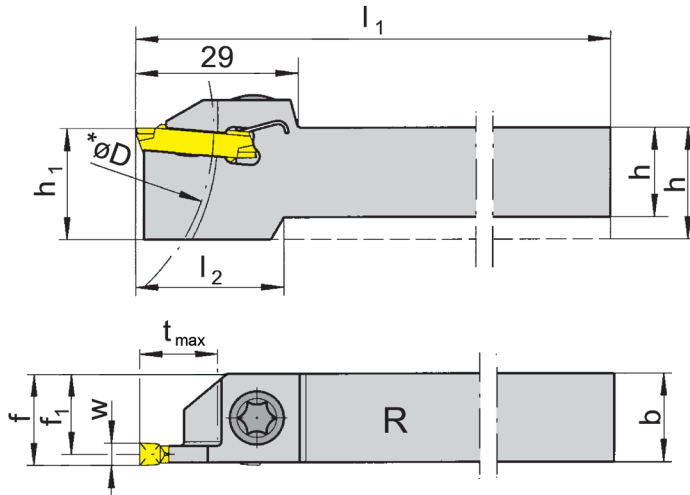

R = right hand version shown

L = left hand version

Part number	h	b	l ₁	l ₂	h ₁	f ₁	f	t _{max}	D _{max}	Size	Clamping range
R/LH224.1616.01	16	16	125	25	20	15.3	f ₁ +w/2	14	80	01	2.0 - 2.4
R/LH224.2020.01	20	20	125	-	20	19.3	f ₁ +w/2	14	80	01	2.0 - 2.4
R/LH224.2525.01	25	25	150	-	25	24.3	f ₁ +w/2	14	80	01	2.0 - 2.4
R/LH224.1616.02	16	16	125	25	20	15.1	f ₁ +w/2	14	80	02	2.4 - 2.8
R/LH224.2020.02	20	20	125	-	20	19.1	f ₁ +w/2	14	80	02	2.4 - 2.8
R/LH224.2525.02	25	25	150	-	25	24.1	f ₁ +w/2	14	80	02	2.4 - 2.8
R/LH224.1616.03	16	16	125	25	20	14.9	f ₁ +w/2	14	80	03	2.8 - 3.7
R/LH224.2020.03	20	20	125	-	20	18.9	f ₁ +w/2	14	80	03	2.8 - 3.7
R/LH224.2525.03	25	25	150	-	25	23.9	f ₁ +w/2	14	80	03	2.8 - 3.7

State R or L version

w see indexable inserts

Dimensions in mm

Further sizes upon request

* t_{max} up to D = 80 mm

For torque specification of the screw, please see Technical Instructions.

Spare Parts

Toolholder	Clamping Screw	TORX PLUS® Wrench
R/LH224...	6.23T25P	T25PQ



Toolholder

HU224

Depth of groove up to
Clamping range

.709"
.079 - .146"

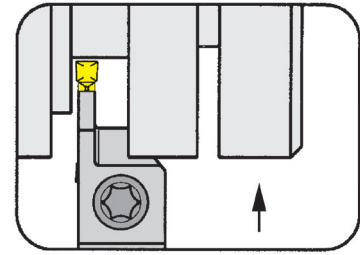

for Indexable insert

Type S224
NS224

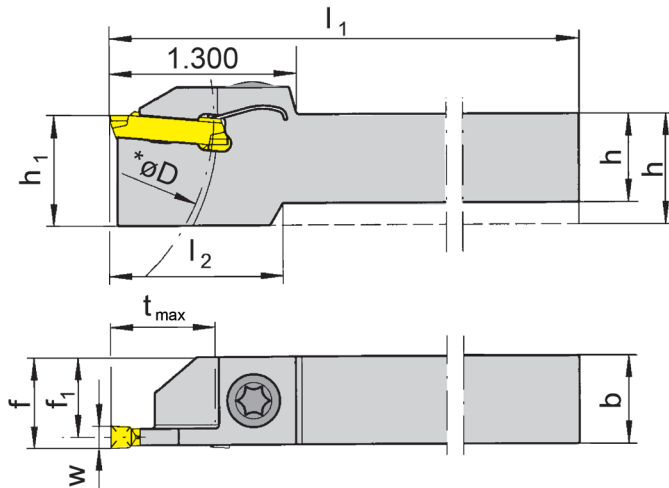

R = right hand version shown

L = left hand version

Part number	h	b	l ₁	l ₂	h ₁	f ₁	f	t _{max}	D _{max}	Size	Clamping range
R/LHU224.0625.21	.625	.625	5.118	1.299	.787	.597	f ₁ +w/2	.709	3.15	01	.079 - .094
R/LHU224.0750.21	.750	.750	4.921	1.299	.750	.722	f ₁ +w/2	.709	3.15	01	.079 - .094
R/LHU224.1000.21	1.000	1.000	6.004	1.299	1.000	.972	f ₁ +w/2	.709	3.15	01	.079 - .094
R/LHU224.0625.22	.625	.625	5.118	1.299	.787	.589	f ₁ +w/2	.709	3.15	02	.094 - .110
R/LHU224.0750.22	.750	.750	4.921	1.299	.750	.715	f ₁ +w/2	.709	3.15	02	.094 - .110
R/LHU224.1000.22	1.000	1.000	6.004	1.299	1.000	.965	f ₁ +w/2	.709	3.15	02	.094 - .110
R/LHU224.0625.23	.625	.625	4.921	1.299	.787	.581	f ₁ +w/2	.709	3.15	03	.110 - .146
R/LHU224.0750.23	.750	.750	4.921	1.299	.750	.707	f ₁ +w/2	.709	3.15	03	.110 - .146
R/LHU224.1000.23	1.000	1.000	6.004	1.299	1.000	.957	f ₁ +w/2	.709	3.15	03	.110 - .146

State R or L version

w see indexable inserts

Dimensions in inch

Further sizes upon request

* t_{max} up to D = 3.150"

For torque specification of the screw, please see Technical Instructions.

Spare Parts

Toolholder	Clamping Screw	TORX PLUS® Wrench
R/LHU224...	6.23T25P	T25PQ

Toolholder

H224

Depth of groove up to
Clamping range

18 mm
2 - 3.7 mm

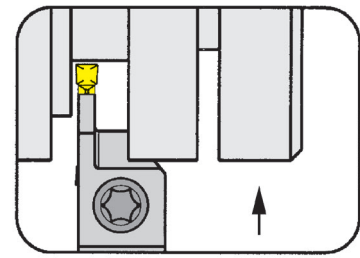

for Indexable insert

Type S224
NS224

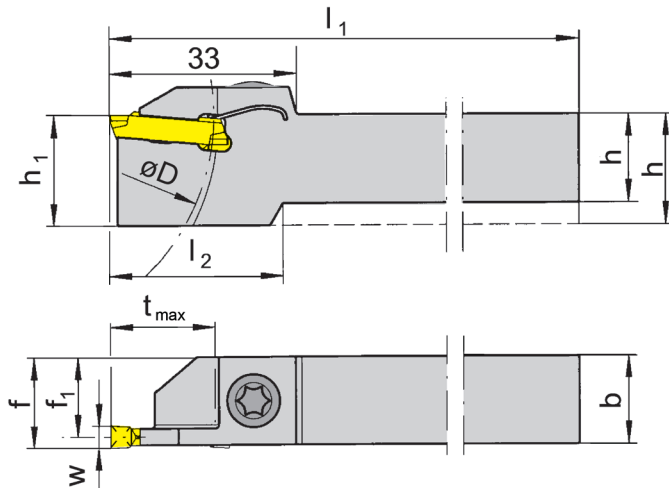

R = right hand version shown

L = left hand version

Part number	h	b	l ₁	l ₂	h ₁	f ₁	f	t _{max}	D _{max}	Size	Clamping range
R/LH224.1616.21	16	16	125	30	20	15.3	f ₁ +w/2	18	80	01	2.0 - 2.4
R/LH224.2020.21	20	20	125	-	20	19.3	f ₁ +w/2	18	80	01	2.0 - 2.4
R/LH224.2525.21	25	25	150	-	25	24.3	f ₁ +w/2	18	80	01	2.0 - 2.4
R/LH224.1616.22	16	16	125	30	20	15.1	f ₁ +w/2	18	80	02	2.4 - 2.8
R/LH224.2020.22	20	20	125	-	20	19.1	f ₁ +w/2	18	80	02	2.4 - 2.8
R/LH224.2525.22	25	25	150	-	25	24.1	f ₁ +w/2	18	80	02	2.4 - 2.8
R/LH224.1608.23	16	8	100	-	20	6.9	f ₁ +w/2	18	80	03	2.8 - 3.7
R/LH224.1616.23	16	16	125	30	20	14.9	f ₁ +w/2	18	80	03	2.8 - 3.7
R/LH224.2020.23	20	20	125	-	20	18.9	f ₁ +w/2	18	80	03	2.8 - 3.7
R/LH224.2525.23	25	25	150	-	25	23.9	f ₁ +w/2	18	80	03	2.8 - 3.7

State R or L version

w see indexable inserts

Dimensions in mm

Further sizes upon request

* t_{max} up to D = 80 mm

For torque specification of the screw, please see Technical Instructions.

Spare Parts

Toolholder	Clamping Screw	TORX PLUS® Wrench
R/LH224...	6.23T25P	T25PQ
R/LH224.1608.23	4.15T15P	T15PQ



Toolholder

H224

with self clamping

Depth of groove up to
Clamping range

18 mm
2 - 3.7 mm

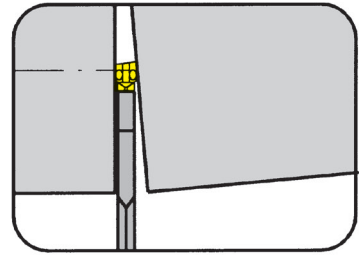

for Indexable insert

Type S224

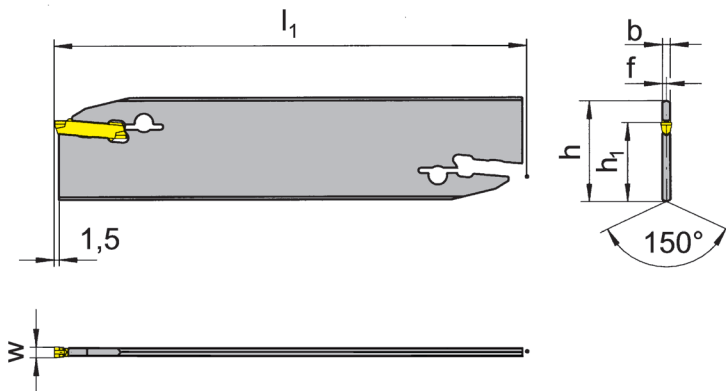

Part number	h	b	l_1	h_1	f	t_{max}	Size	Clamping range
H224.2602.02	26	1.9	110	21.4	.95	18	02	2.4 - 2.8
H224.2603.03	26	2.3	110	21.4	1.15	18	03	2.8 - 3.7
H224.3203.03	32	2.3	150	24.8	1.15	18	03	2.8 - 3.7

Further sizes upon request

w see indexable inserts

Dimensions in mm

Note:

Wrench **P39L** is not combined with toolholder - separate order required!

Toolholder

H224

reinforced version

Depth of groove up to
Width of groove

11 mm
2 - 3 mm

for machines TRAUB (TNL18P)

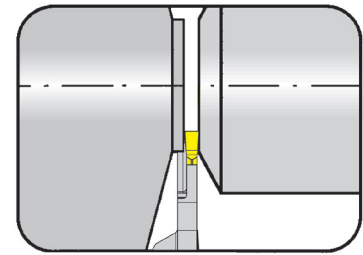

for Indexable insert

Type S224

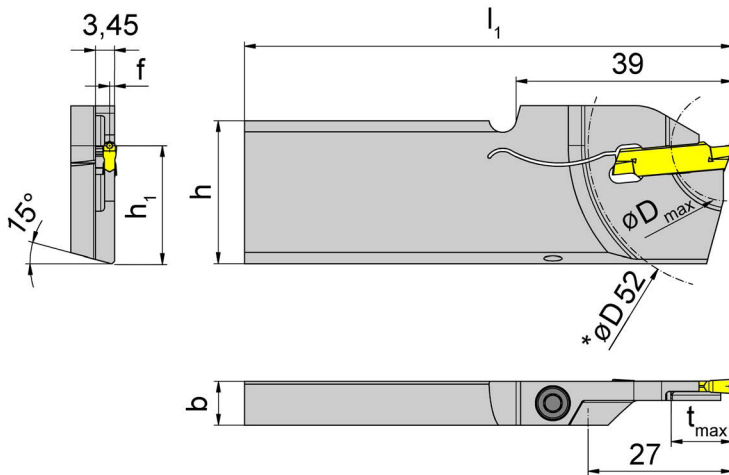

L = left hand version

Part number	h	b	l_1	h_1	f	t_{max}	D_{max}	Size	Clamping range
LH224.2608.20.T.81	26	7.9	88	21.4	.7	11	20	01	2.0
LH224.2608.20.T.82	26	7.9	88	21.4	.9	11	20	02	2.5
LH224.2608.20.T.83	26	7.9	88	21.4	1.1	11	20	03	3.0

Further sizes upon request

*D 52 = D_{max} of the subspindle

Dimensions in mm

For torque specification of the screw, please see Technical Instructions.

Spare Parts

Toolholder	Clamping Screw	TORX PLUS® Wrench
LH224...	4.15T15P	T15PQ



Toolholder

H224

reinforced version

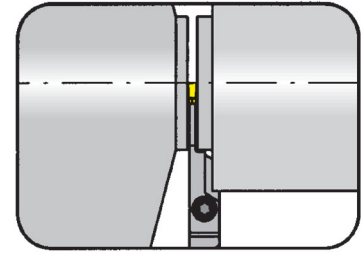

Depth of groove up to	18 mm
Clamping range	2.0 - 3.7 mm

for machines TRAUB (TNK28/TNK36/TNL26)

for Indexable insert

Type S224

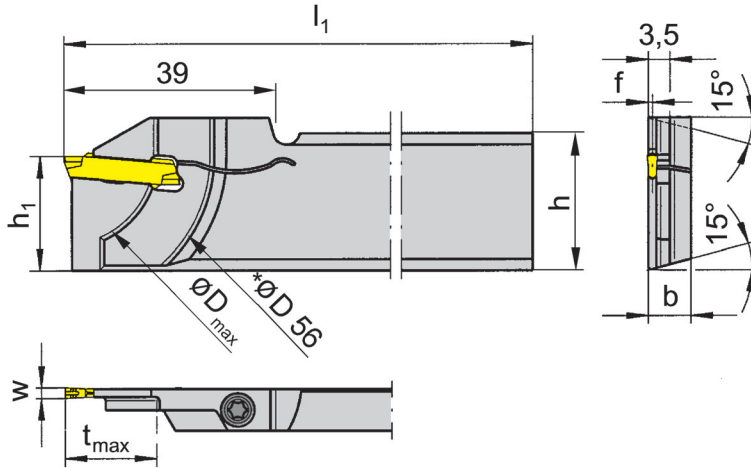

R = right hand version shown

L = left hand version

Part number	h	b	l ₁	h ₁	f	t _{max}	D _{max}	Size	Clamping range
R/LH224.2608.81	26	7.9	110	21.4	.75	18	36	01	2.0 - 2.4
R/LH224.2608.82	26	7.9	110	21.4	.95	18	36	02	2.4 - 2.8
R/LH224.2608.83	26	7.9	110	21.4	1.10	18	36	03	2.8 - 3.7

State R or L version

w see indexable inserts

Dimensions in mm

*D 56 = D_{max} of the subspindle

Further sizes upon request

For torque specification of the screw, please see Technical Instructions.

Spare Parts

Toolholder	Clamping Screw	TORX PLUS® Wrench
R/LH224...	4.15T15P	T15PL

Toolholder

H224

reinforced version

Depth of groove up to
Clamping range

21 mm
2 - 3.7 mm

for machines TRAUB (TNK28/TNK36/TNL26)

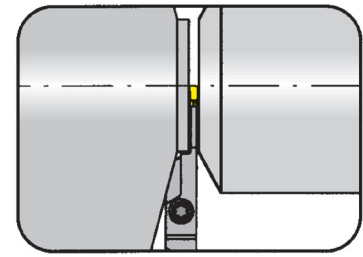

for Indexable insert

Type S224

224
NS224

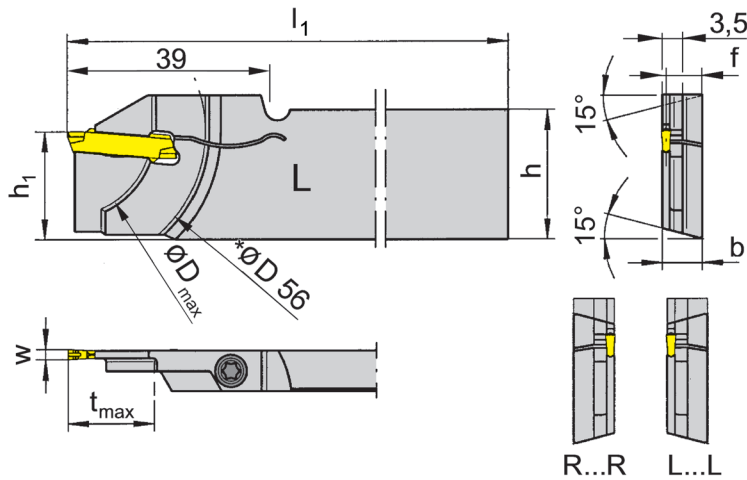

L = left hand version shown

R = right hand version

Part number	h	b	l ₁	h ₁	f	t _{max}	D _{max}	Size	Clamping range
LH224.2608.81L	26	7.9	110	21.4	7.15	18	36	01	2.0 - 2.4
RH224.2608.81R	26	7.9	110	21.4	7.15	18	36	01	2.0 - 2.4
LH224.2608.82L	26	7.9	110	21.4	6.95	18	36	02	2.4 - 2.8
RH224.2608.82R	26	7.9	110	21.4	6.95	18	36	02	2.4 - 2.8
LH224.2608.83L	26	7.9	110	21.4	6.75	18	36	03	2.8 - 3.7
RH224.2608.83R	26	7.9	110	21.4	6.75	18	36	03	2.8 - 3.7
RH224.3208.83R	32	7.9	110	24.8	6.80	21	42	03	2.8 - 3.7

Further sizes upon request

w see indexable inserts

Dimensions in mm

*D 56 = D_{max} of the subspindle

* For specific clamping device on subspindle (e.g. HAINBUCH Axfixchuck)

For torque specification of the screw, please see Technical Instructions.

Spare Parts

Toolholder	Clamping Screw	TORX PLUS® Wrench
R/LH224...	4.15T15P	T15PL
RH224.3208.83R/L	5.13 T20P	T20PQ



Toolholder

H224

reinforced version

Depth of groove up to
Clamping range

18 mm
2 - 3.7 mm

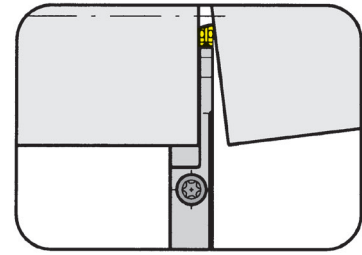

for Indexable insert

Type S224

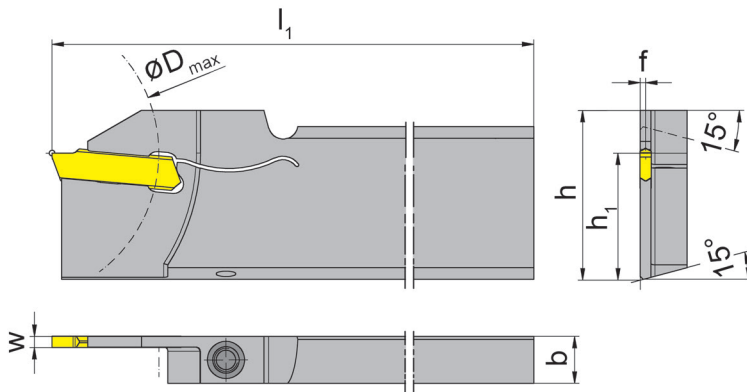

R = right hand version shown

L = left hand version

Part number	h	b	l ₁	h ₁	f	t _{max}	D _{max}	Size	Clamping range
R/LH224.2608.01	26	7.9	110	21.4	.7	18	50	01	2.0 - 2.4
R/LH224.3208.01	32	7.9	110	24.8	.7	18	50	01	2.0 - 2.4
R/LH224.2608.02	26	7.9	110	21.4	.9	18	50	02	2.4 - 2.8
R/LH224.3208.02	32	7.9	110	24.8	.9	18	50	02	2.4 - 2.8
R/LH224.2608.03	26	7.9	110	21.4	1.1	18	50	03	2.8 - 3.7
R/LH224.3208.03	32	7.9	110	24.8	1.1	18	50	03	2.8 - 3.7

State R or L version

w see indexable inserts

Dimensions in mm

Further sizes upon request

For torque specification of the screw, please see Technical Instructions.

Parting Off solid Bars

Parting Off tubes

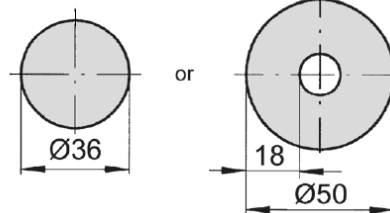

Spare Parts

Toolholder	Clamping Screw	TORX PLUS® Wrench
R/LH224...	4.20T15P	T15PL

Toolholder

H224

reinforced version

Depth of groove up to
Clamping range

18 mm
3 mm

for machines DMG MORI (MULTISPRINT 36)

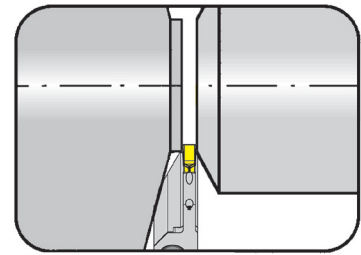

for Indexable insert

Type S224

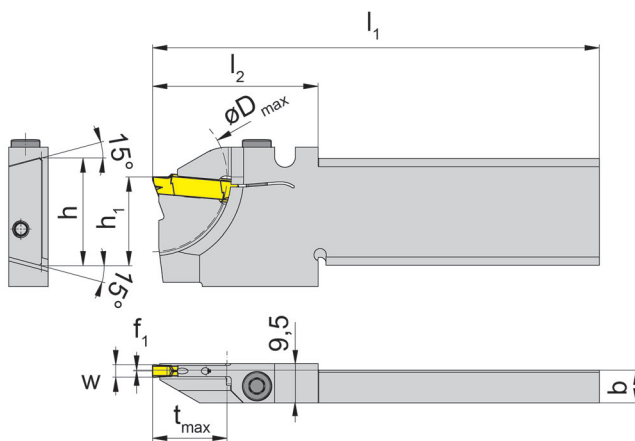

R = right hand version shown

with through coolant supply

Part number	h	b	l_1	h_1	f	t_{max}	D_{max}	Size
RH224.2608.1.18.4.73.IK	26	7.9	108	21.4	.2	18	36	03
RH224.2608.1.18.4.73R.IK	26	7.9	108	21.4	6.4	18	36	03
RH224.2608.2.18.4.73.IK	26	7.9	124	21.4	.2	18	36	03
RH224.2608.2.18.4.73R.IK	26	7.9	124	21.4	6.4	18	36	03

w see indexable inserts

Dimensions in mm

Further sizes upon request

For torque specification of the screw, please see Technical Instructions.

Spare Parts

Toolholder	Clamping Screw	TORX PLUS® Wrench
RH224...	5.13 T20P	T20PQ



Toolholder

H224

with screwed clamping

Depth of groove up to
Clamping range

32.5 mm
2.8 - 3.7 mm

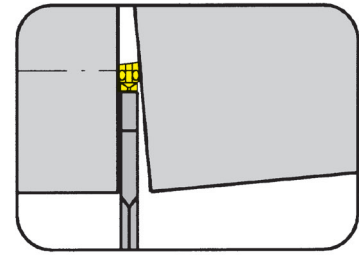

for Indexable insert

Type S224

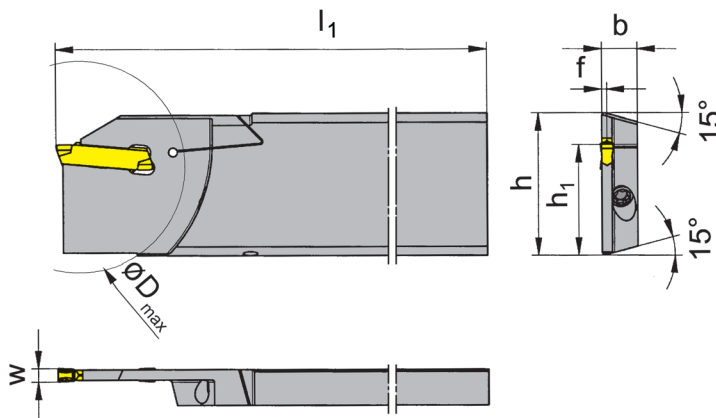

R = right hand version shown

L = left hand version

Part number	h	b	l_1	h_1	f	t_{max}	D_{max}	Size	Clamping range
R/LH224.3208.93	32	8	112	24.8	1.15	32.5	65	03	2.8 - 3.7

State R or L version

w see indexable inserts

Dimensions in mm

Further sizes upon request

For torque specification of the screw, please see Technical Instructions.

Spare Parts

Toolholder	Clamping Screw	TORX PLUS® Wrench	Pin
R/LH224.3208.93	030.0413.T15P	T15PQ	020.0040.0999

U64

Call Us Toll Free (888) 818-4676

Indexable insert

S224

with chip forming

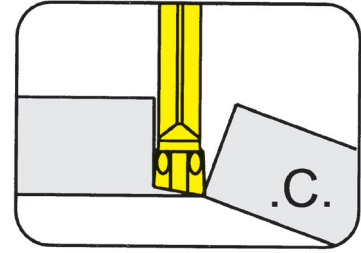

Depth of groove up to
Width of groove

.709"
.079 - .118"

precision sintered

for Toolholder

Type H224
HU224

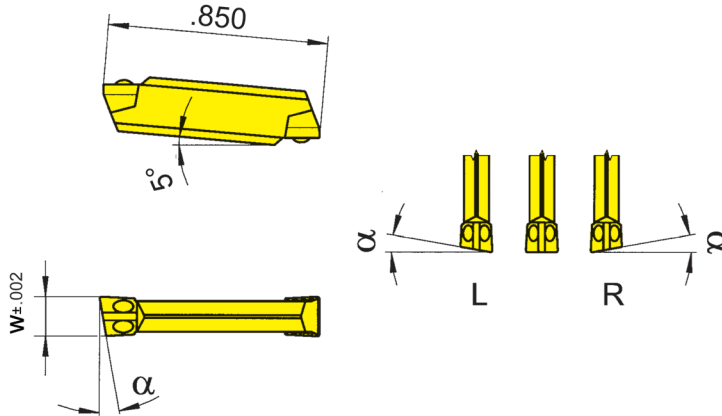

R = right hand version shown

L = left hand version

Part number	w	α	Size	Carbide grades			
				TC92	TF45	TI25	TN35
S224.0020.C0	.079	0°	01	x	▲	▲	▲
R/LS224.0520.C0	.079	5°	01	x/x	▲/▲	x/x	▲/▲
R/LS224.0820.C0	.079	8°	01	x/x	▲/▲	x/x	▲/▲
R/L/S224.1520.C0	.079	15°	01	Δ/x	▲/▲	x/x	▲/▲
S224.0025.C0	.098	0°	02	x	▲	▲	▲
R/LS224.0525.C0	.098	5°	02	x/x	▲/x	▲/x	▲/▲
R/L/S224.0825.C0	.098	8°	02	x/x	Δ/x	x/x	▲/▲
S224.0030.C0	.118	0°	03	x	▲	▲	▲
R/LS224.0530.C0	.118	5°	03	▲/x	▲/▲	x/x	▲/▲
R/L/S224.0830.C0	.118	8°	03	x/x	▲/Δ	x/x	▲/▲
▲ on stock Δ 4 weeks x upon request				P	•	•	•
● recommended				M	-	•	•
○ alternative recommendation				K	-	•	•
- not suitable				N	-	•	•
■ uncoated grades				S	-	•	•
■ coated grades				H	-	-	-
■ brazed/Cermet							

Dimensions in inch

State R or L version

Further sizes upon request

Indexable inserts can be used in right and left hand toolholders.



Indexable insert

S224

with chip forming

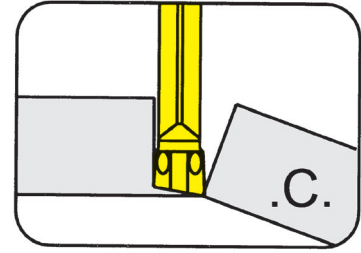

Depth of groove up to	.709"
Width of groove	.079 - .118"

precision sintered

for Toolholder

Type H224
HU224

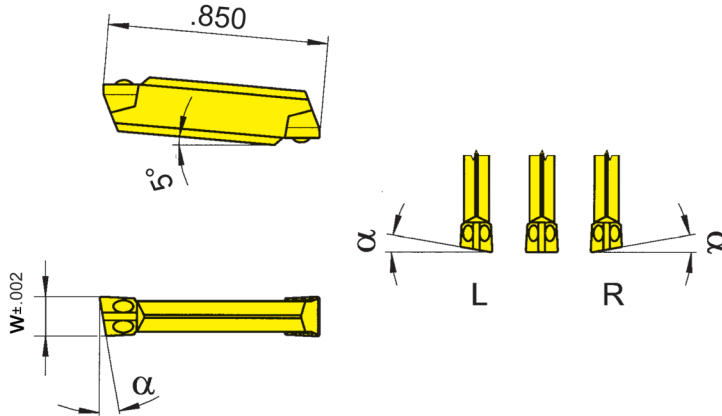

R = right hand version shown

L = left hand version

Part number	w	r	α	Size	Carbide grades			
					TC92	TF45	TI25	TN35
S224.0020.C1	.079	.006	0°	01	▲	▲	▲	▲
R/LS224.0520.C1	.079	.006	5°	01	x/x	▲/▲		▲/▲
R/LS224.0820.C1	.079	.006	8°	01	x/x	▲/Δ		x/x
R/LS224.1520.C1	.079	.006	15°	01	x/x	▲/Δ		▲/▲
S224.0025.C1	.098	.006	0°	02	x	▲	▲	▲
R/LS224.0525.C1	.098	.006	5°	02	x/x	▲/▲		▲/Δ
R/LS224.0825.C1	.098	.006	8°	02	x/x	▲/▲		x/x
S224.0030.C1	.118	.006	0°	03	▲	▲	▲	▲
R/LS224.0530.C1	.118	.006	5°	03	x/x	▲/Δ		▲/▲
R/LS224.0830.C1	.118	.006	8°	03	x/x	▲/▲		▲/▲

▲ on stock Δ 4 weeks x upon request

● recommended

○ alternative recommendation

- not suitable

■ uncoated grades

■ coated grades

■ brazed/Cermet

Dimensions in inch

State R or L version

Further sizes upon request

Indexable inserts can be used in right and left hand toolholders.

	P	M	K	N	S	H
TC92	●	●	●	●	●	●
TF45	-	●	●	●	●	●
TI25	-	●	●	●	●	●
TN35	-	●	●	●	●	●

Carbide grades

Indexable insert

S224

with chip forming

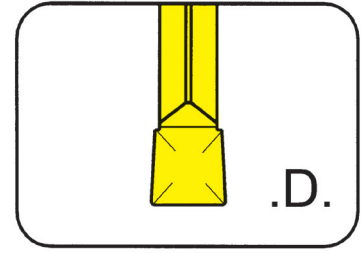

Depth of groove up to	.709"
Width of groove	.079 - .118"

precision sintered

for Toolholder

Type H224
HU224

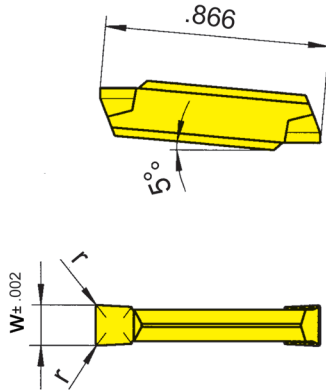

Indexability length
± .002"

Part number	w	r	Size	H54	TF45	TF46	Ti25	TN32	TN35
				S224.0200.D2	.079	.008	01	▲	▲
S224.0250.D2	.098	.008	02	x	▲	▲	▲	▲	▲
S224.0300.D2	.118	.008	03	▲	▲	▲	▲	▲	▲
				P	●	●	●	●	●
				M	●	○	●	-	●
				K	-	●	●	-	●
				N	-	●	●	-	●
				S	-	○	●	-	●
				H	-	-	-	-	-

Carbide grades

▲ on stock Δ 4 weeks x upon request

- recommended
- alternative recommendation
- not suitable

- uncoated grades
- coated grades
- brazed/Cermet

Dimensions in inch

Indexable inserts can be used in right and left hand toolholders.



Indexable insert

S224

with chip former

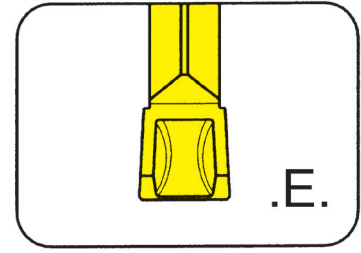

Depth of groove up to .709"
Width of groove .079 - .118"

precision sintered

for Toolholder

Type H224
HU224

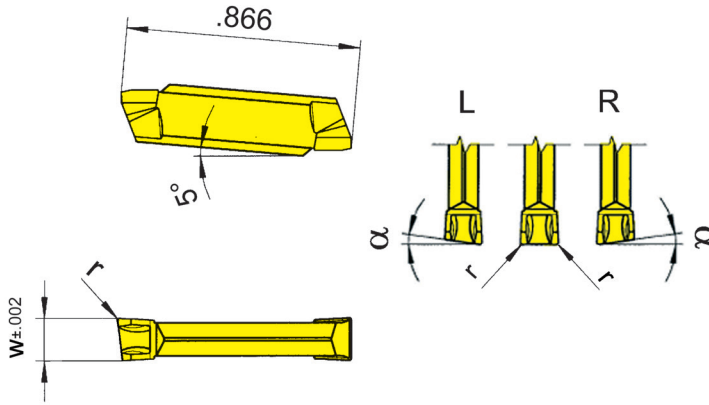

R = right hand version shown

L = left hand version

Part number	w	r	α	Size	AL96	AS62	TA43	TC92	TC93	TF43	TF45	TI22	TI25	TN32	TN35
S224.0200.E2	.079	.008	0°	01		▲		▲	▲	▲	▲				
R/LS224.0520.E2	.079	.008	5°	01		▲/▲		x/x	x/x	x/x	x/x				
S224.0250.E2	.098	.008	0°	02		▲		▲	x	▲	▲				
R/LS224.0525.E2	.098	.008	5°	02		▲/▲		x/x	x/x	x/x	Δ/x				
S224.0300.E2	.118	.008	0°	03	x	▲	x	▲	▲	▲	▲	▲	▲	x	x
S224.0300.E4	.118	.016	-	03	x	▲		x	x	▲	▲		x	x	x
R/LS224.0530.E2	.118	.008	5°	03		▲/▲		▲/x	x/x	▲/x	▲/▲				
▲ on stock Δ 4 weeks x upon request					P	•	•	•	•	•	•	•	•	•	•
● recommended					M	-	-	-	-	-	•	-	•	-	•
○ alternative recommendation					K	•	-	-	-	-	•	-	•	-	•
- not suitable					N	•	-	-	-	-	•	-	•	-	•
■ uncoated grades					S	-	-	-	-	-	•	-	•	-	•
■ coated grades					H	-	-	-	-	-	-	-	-	-	-
■ brazed/Cermet															

Dimensions in inch

Carbide grades

State R or L version

Further sizes upon request

Indexable inserts can be used in right and left hand toolholders.

Toolholder

H224

with screwed clamping

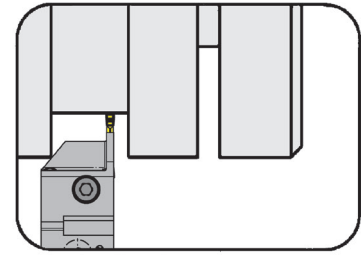

Depth of groove up to 18 mm
Width of groove 3 mm

for Indexable insert

Type S224...IK

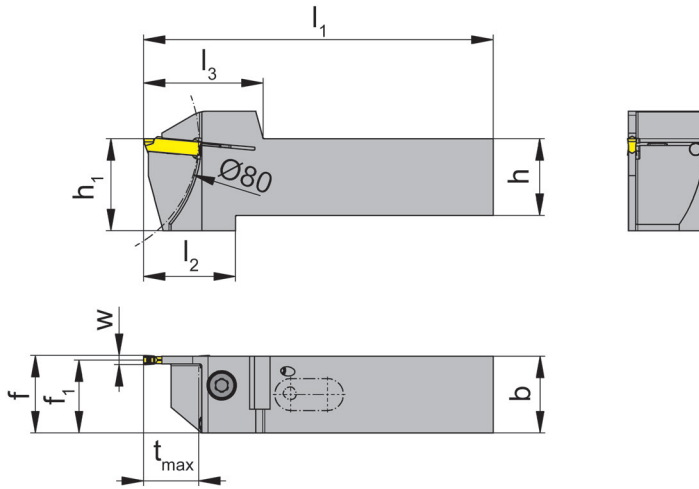

L = left hand version shown

R = right hand version

Coolant supply through insert

Part number	h	b	l ₁	l ₂	l ₃	h ₁	f ₁	f	t _{max}	Size
R/LH224.1616.3.23.IK	16	16	87	33	39	25	14.75	f ₁ +w/2	18	03
R/LH224.2020.3.23.IK	20	20	99	30	39	25	18.75	f ₁ +w/2	18	03
R/LH224.2525.3.23.IK	25	25	114	30	39	30	23.75	f ₁ +w/2	18	03

State R or L version

w see indexable inserts

Dimensions in mm

Further sizes upon request

For torque specification of the screw, please see Technical Instructions.

Spare Parts

Toolholder	Clamping Screw	TORX PLUS® Wrench	O - ring	Threaded Pin
R/LH224...3.23.IK	6.23T25P	T25PQ	12.37.2.62.3601	4.06.913



Indexable insert

S224

with chip former

Width of groove	.118"
-----------------	-------

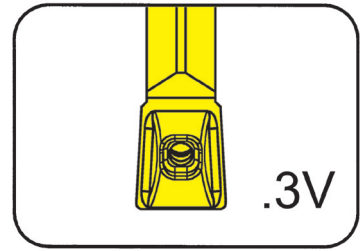

for Toolholder

Type H224...IK

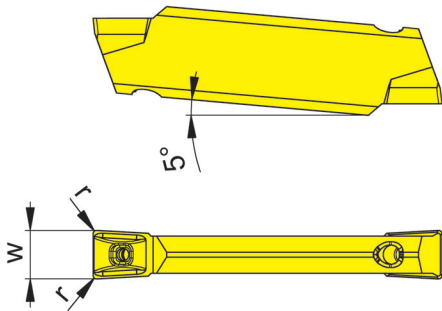

Coolant supply through insert

Part number	w	r	Size	Carbide grades	
				HP65	IG35
S224.0300.3V2.IK	.118	.008	03	▲	x
▲ on stock Δ 4 weeks x upon request				P	•
● recommended				M	•
○ alternative recommendation				K	•
- not suitable				N	○
□ uncoated grades				S	•
■ coated grades				H	-
■ brazed/Cermet					-

Dimensions in inch

Indexable inserts can be used in right and left hand toolholders.

U

Indexable insert

S224

with chip forming

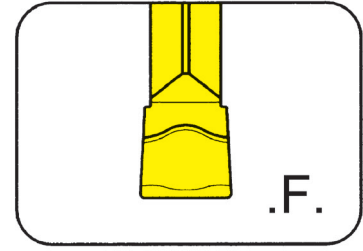

Depth of groove up to $.709''$
Width of groove $.079 - .118''$

for Toolholder

Type H224

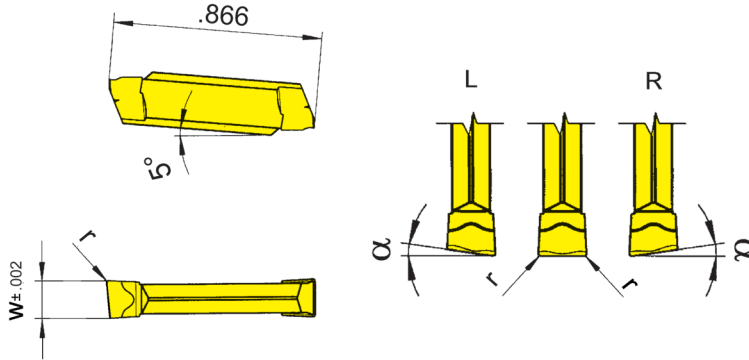

R = right hand version shown

L = left hand version

Part number	w	r	α	Size	AL96	TA43	TF42	TF43	TF45	TF46	TI22	TI25	TN32
S224.0200.F2	.079	.008	0°	01	x		x	▲	▲	▲	▲	▲	x
R/LS224.0520.F2	.079	.008	5°	01					▲/▲	▲/Δ			
S224.0250.F2	.098	.008	0°	02	x		x	▲	▲	▲	▲	x	x
R/LS224.0525.F2	.098	.008	5°	02				▲/Δ	▲/Δ				
S224.0300.F2	.118	.008	0°	03	x	x		▲	▲	▲	x	▲	x
R/LS224.0530.F2	.118	.008	5°	03				▲/Δ	▲/▲		▲/x		
▲ on stock Δ 4 weeks x upon request					P	•	•	•	•	•	•	•	•
• recommended					M	-	-	-	•	o	-	•	-
o alternative recommendation					K	•	-	-	•	•	-	•	-
- not suitable					N	•	-	-	•	•	-	•	-
■ uncoated grades					S	-	-	-	•	o	-	•	-
■ coated grades					H	-	-	-	-	-	-	-	-
■ brazed/Cermet													

Dimensions in inch

Carbide grades

State R or L version

Indexable inserts can be used in right and left hand toolholders.



Toolholder

H264

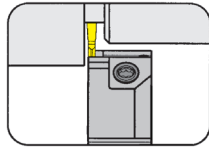

Page
U74 - U77

Indexable insert

264

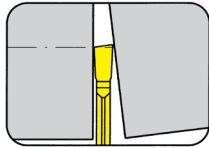

Page
U78 - U79

264

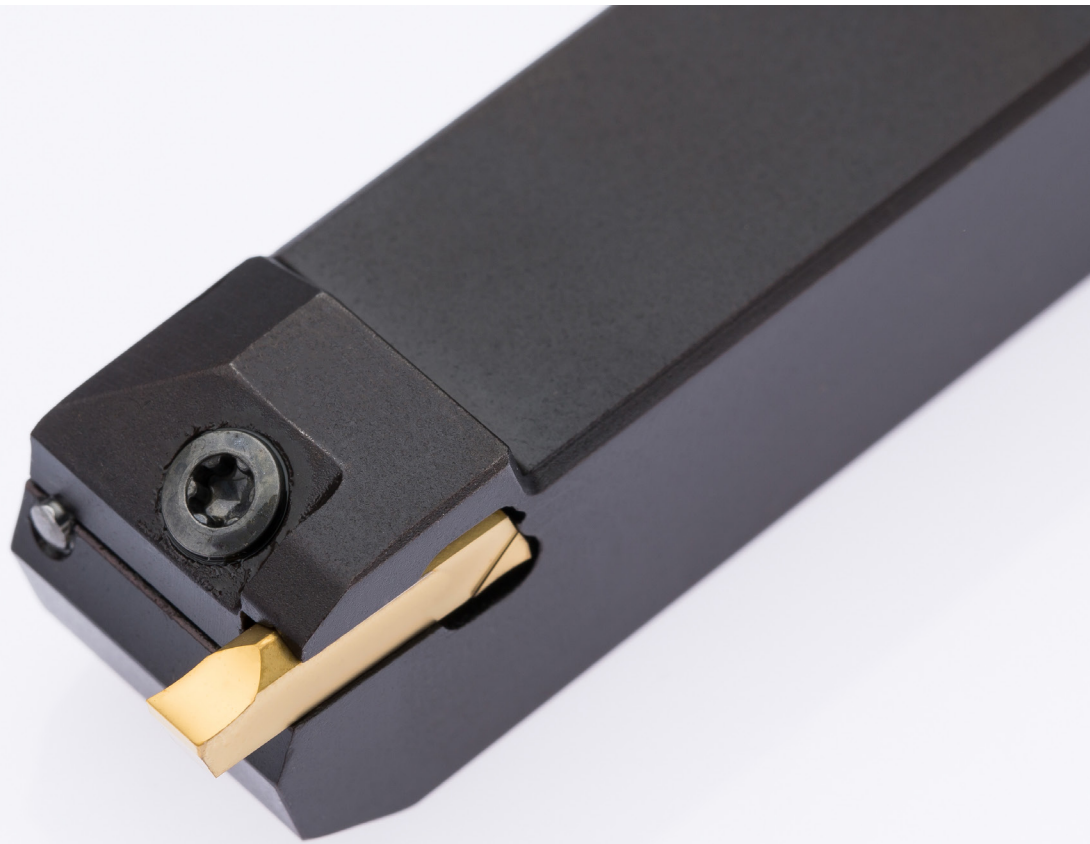

Toolholder with Inserts

Width of groove .059 - .118"

U

Toolholder

H264

with screwed clamping

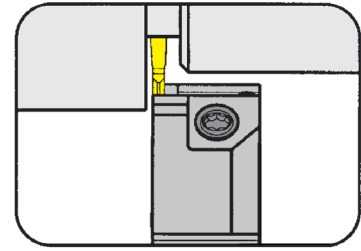

Depth of groove up to
Width of groove

16 mm
1.5 - 2 mm

for Indexable insert

Type 264

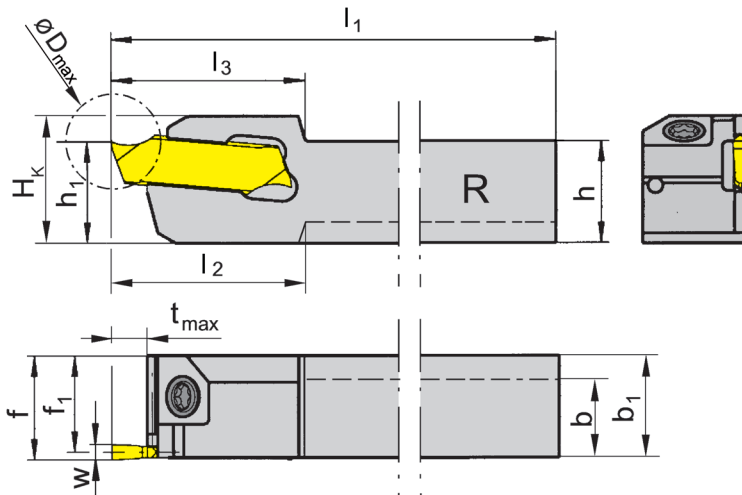

R = right hand version shown

L = left hand version

Part number	h	b	l ₁	l ₂	l ₃	h ₁	b ₁	f ₁	f	t _{max}	D _{max}	H _K	Size
R/LH264.0808.01	8	10	120	17.5	17.5	8	10	9.25	10	4	22	12.5	01
R/LH264.1010.01	10	10	120	-	17.5	10	-	9.25	10	4	22	12.5	01
R/LH264.1212.01	12	12	120	-	17.5	12	-	11.25	12	4	22	14.5	01
R/LH264.1616.01	16	16	120	-	17.5	16	-	15.25	16	4	32	18.5	01
R/LH264.1010.11	10	10	120	-	19.0	10	-	9.25	10	10	20	12.5	01
R/LH264.1212.11	12	12	120	-	19.0	12	-	11.25	12	10	20	14.5	01
R/LH264.1616.11	16	16	120	-	19.0	16	-	15.25	16	10	32	18.5	01
R/LH264.1212.21	12	12	120	-	22.0	12	-	11.25	12	13	26	15.5	01
R/LH264.1616.21	16	16	120	-	22.0	16	-	15.25	16	13	32	19.5	01
R/LH264.1010.02	10	10	120	-	17.5	10	-	9.00	10	4	32	12.5	02
R/LH264.1212.02	12	12	120	-	17.5	12	-	11.00	12	4	32	14.5	02
R/LH264.1616.02	16	16	120	-	17.5	16	-	15.00	16	4	32	18.5	02
R/LH264.1010.12	10	10	120	-	19.0	10	-	9.00	10	10	32	12.5	02
R/LH264.1212.12	12	12	120	-	19.0	12	-	11.00	12	10	32	14.5	02
R/LH264.1616.12	16	16	120	-	19.0	16	-	15.00	16	10	32	18.5	02
R/LH264.1212.22	12	12	120	-	25.0	12	-	11.00	12	16	32	14.5	02
R/LH264.1616.22	16	16	120	-	25.0	16	-	15.00	16	16	32	19.5	02

State R or L version

w see indexable inserts

Dimensions in mm

Further sizes upon request

For torque specification of the screw, please see Technical Instructions.

Spare Parts

Toolholder	Clamping Screw	TORX PLUS® Wrench
R/LH264...	3.5.12T10EP	T10PL

Toolholder

H264

with screwed clamping

Depth of groove up to
Width of groove

16 mm
2.5 mm

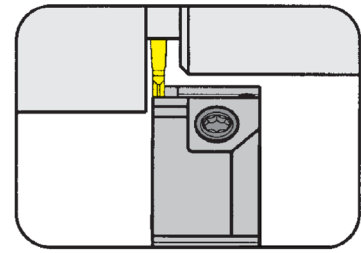

for Indexable insert

Type 264

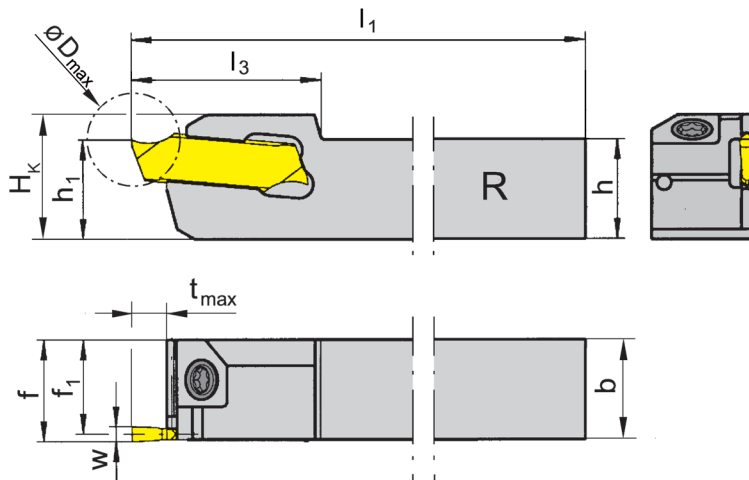

R = right hand version shown

L = left hand version

Part number	h	b	l ₁	l ₃	h ₁	f ₁	f	t _{max}	D _{max}	H _k	Size
R/LH264.1212.03	12	12	120	17.5	12	10.75	12	4	32	14.5	03
R/LH264.1616.03	16	16	120	17.5	16	14.75	16	4	32	18.5	03
R/LH264.1212.13	12	12	120	19.0	12	10.75	12	10	32	14.5	03
R/LH264.1616.13	16	16	120	19.0	16	14.75	16	10	32	18.5	03
R/LH264.1212.23	12	12	120	25.0	12	10.75	12	16	32	14.5	03
R/LH264.1616.23	16	16	120	25.0	16	14.75	16	16	32	18.5	03

State R or L version

w see indexable inserts

Dimensions in mm

Further sizes upon request

For torque specification of the screw, please see Technical Instructions.

Spare Parts

Toolholder	Clamping Screw	TORX PLUS® Wrench
R/LH264...	3.5.12T10EP	T10PL



Toolholder

H264

with screwed clamping

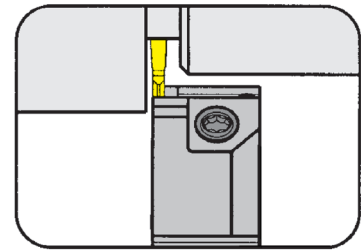

Depth of groove up to
Width of groove

16 mm
3 mm

for Indexable insert

Type 264

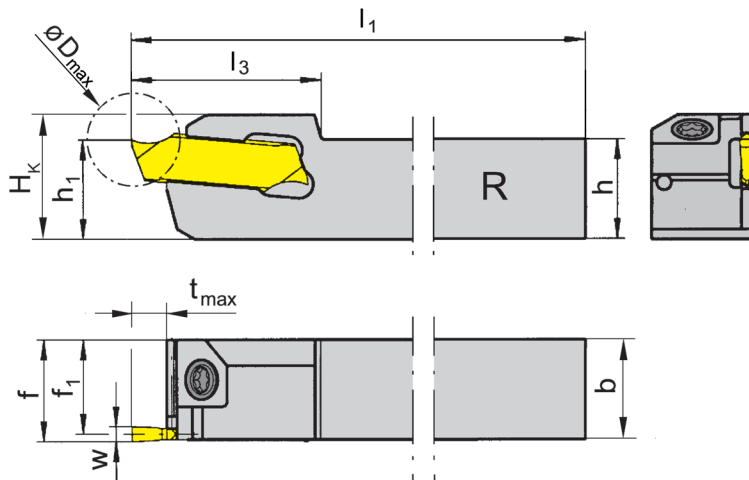

R = right hand version shown

L = left hand version

Part number	h	b	l_1	l_3	h_1	f_1	f	t_{max}	D_{max}	H_K	Size
R/LH264.1212.04	12	12	120	17.5	12	10.5	12	5	32	15	04
R/LH264.1616.04	16	16	120	17.5	16	14.5	16	5	32	19	04
R/LH264.1212.14	12	12	120	19.0	12	10.5	12	10	32	15	04
R/LH264.1616.14	16	16	120	19.0	16	14.5	16	10	32	19	04
R/LH264.1212.24	12	12	120	25.0	12	10.5	12	16	32	15	04
R/LH264.1616.24	16	16	120	25.0	16	14.5	16	16	32	19	04

State R or L version

w see indexable inserts

Dimensions in mm

Further sizes upon request

For torque specification of the screw, please see Technical Instructions.

Spare Parts

Toolholder	Clamping Screw	TORX PLUS® Wrench
R/LH264...	3.5.12T10EP	T10PL

Grooving and Parting Off



Toolholder

H264

with self clamping

Depth of groove up to
Width of groove

10 mm
1.5 - 3 mm

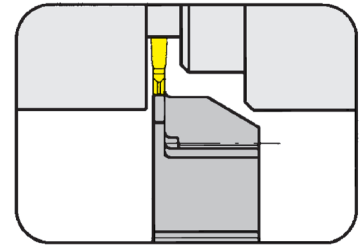

for Indexable insert

Type 264

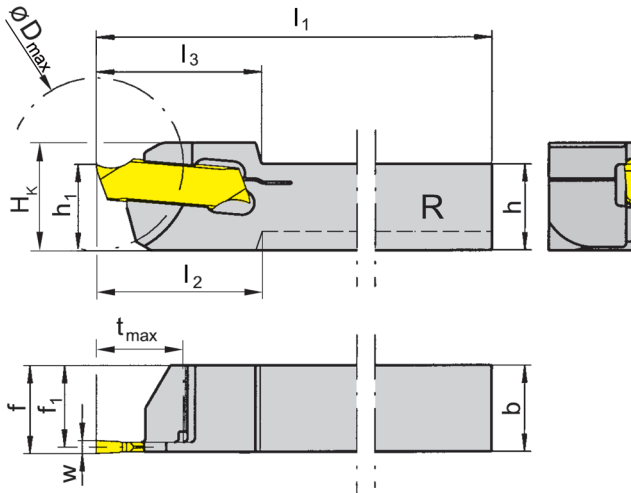

R = right hand version shown

L = left hand version

Part number	h	b	l ₁	l ₂	l ₃	h ₁	f ₁	f	t _{max}	D _{max}	H _K	Size
R/LH264.0808.51	8	8	120	18	18	10	7.25	8	7	20	12.5	01
R/LH264.1010.61	10	10	120	-	19	10	9.25	10	10	20	12.5	01
R/LH264.1010.62	10	10	120	-	19	10	9.00	10	10	20	12.5	02
R/LH264.1212.62	12	12	120	-	19	12	11.00	12	10	20	14.5	02
R/LH264.1212.63	12	12	120	-	19	12	10.75	12	10	32	14.5	03
R/LH264.1212.64	12	12	120	-	19	12	10.50	12	10	32	14.5	04

State R or L version

w see indexable inserts

Dimensions in mm

Further sizes upon request

Note:

Wrench **P39L** is not combined with toolholder - separate order required!

Spare Parts

Toolholder	Wrench
R/LH264...	P39L



Indexable insert

264

Depth of groove up to .630"
Width of groove .059 - .118"

precision ground

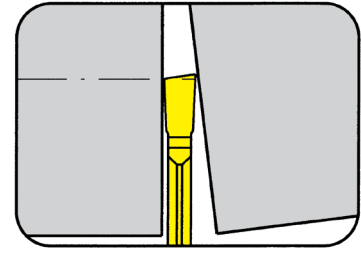

for Toolholder

Type H264

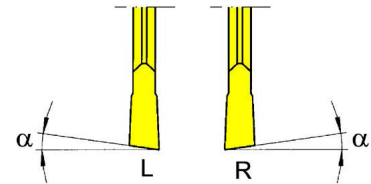
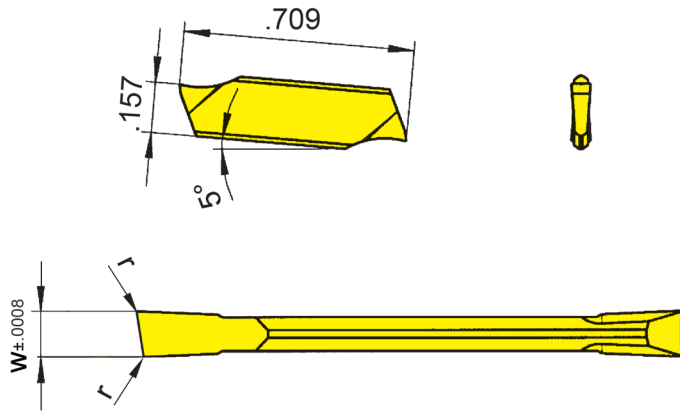

Indexability length ± .0006"

R = right hand version shown

L = left hand version

Part number	w	r	α	Size	MG12	TH35	T125	TN35
					MG12	TH35	T125	TN35
R/L264.0815.10	.059	.002	8°	01	Δ/▲	▲/▲	x/x	▲/▲
R/L264.1515.10	.059	.002	15°	01	▲/▲	▲/▲		▲/▲
R/L264.0820.10	.079	.002	8°	02	▲/▲	▲/▲		▲/▲
R/L264.1520.10	.079	.002	15°	02	▲/▲	▲/▲		▲/▲
R/L264.0825.10	.098	.004	8°	03	x/x	▲/▲		▲/▲
R/L264.1525.10	.098	.004	15°	03	x/x	▲/▲		▲/▲
R/L264.0830.10	.118	.004	8°	04	x/x	▲/▲		▲/▲
R/L264.1530.10	.118	.004	15°	04	x/x	▲/▲		▲/▲

- ▲ on stock Δ 4 weeks x upon request
- recommended
- alternative recommendation
- not suitable
- uncoated grades
- coated grades
- brazed/Cermet

P	○	●	●	●
M	-	●	●	●
K	-	●	●	●
N	-	●	●	●
S	-	●	●	●
H	-	-	-	-

Carbide grades

Dimensions in inch

State R or L version

Indexable inserts can be used in right and left hand toolholders.

Indexable insert

264

Depth of groove up to .630"
Width of groove .059 - .118"

precision ground

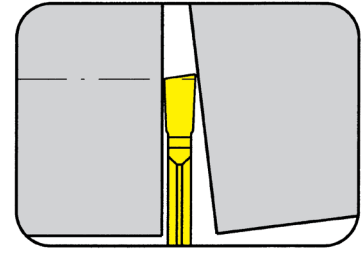

for Toolholder

Type H264

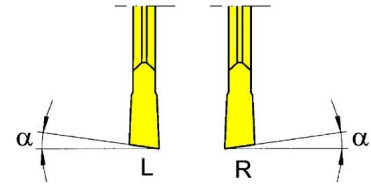
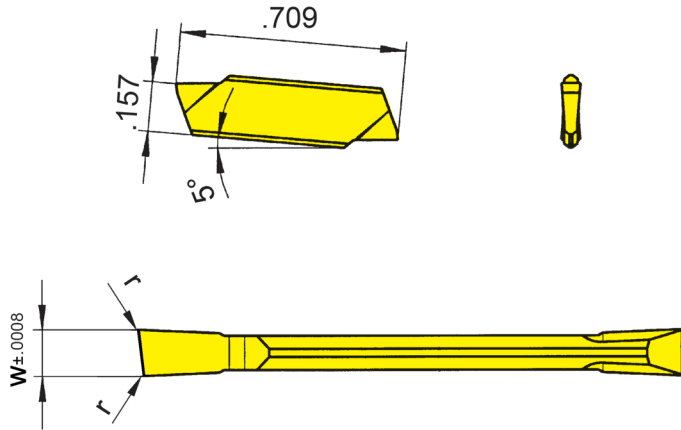

Indexability length ± .0006"

R = right hand version shown

L = left hand version

Part number	w	r	α	Size	MG12	TH35	TN35
R/L264.0815.M0	.059	.002	8°	01	▲/▲	▲/▲	▲/▲
R/L264.1515.M0	.059	.002	15°	01	▲/Δ	▲/▲	▲/▲
R/L264.0820.M0	.079	.002	8°	02	▲/Δ	▲/▲	▲/▲
R/L264.1520.M0	.079	.002	15°	02	Δ/Δ	▲/▲	▲/▲
R/L264.0825.M0	.098	.004	8°	03	x/x	▲/▲	▲/▲
R/L264.1525.M0	.098	.004	15°	03	Δ/Δ	▲/x	▲/x
R/L264.0830.M0	.118	.004	8°	04	x/x	▲/▲	▲/▲
R/L264.1530.M0	.118	.004	15°	04	x/Δ	▲/▲	▲/▲

- ▲ on stock Δ 4 weeks x upon request
- recommended
- alternative recommendation
- not suitable
- uncoated grades
- coated grades
- brazed/Cermet

Dimensions in inch

State R or L version

Indexable inserts can be used in right and left hand toolholders.

P	○	●	●
M	-	●	●
K	-	●	●
N	-	●	●
S	-	●	●
H	-	-	-

Carbide grades



Toolholder
H274/H274...E

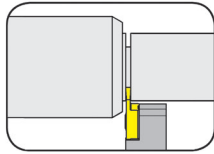

Page
U82, U89

Indexable insert
S274/S274...E

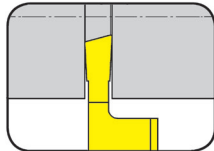

Page
U83-U88
U90-U95

274

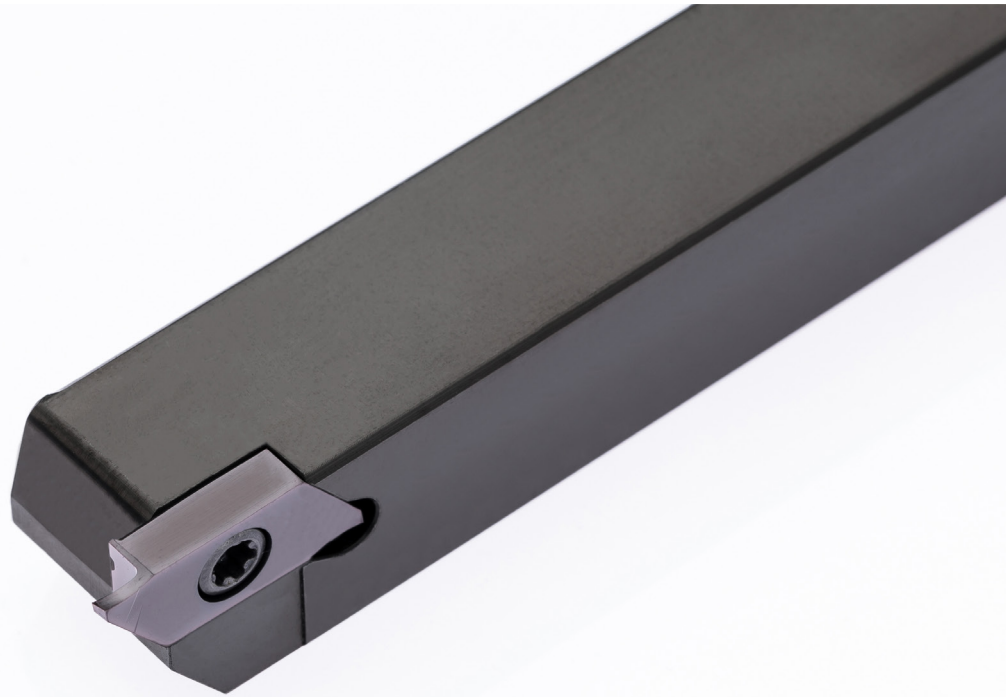

Toolholder with Inserts

Width of groove .031 - .079"

U

Toolholder

H274

Depth of groove
Width of groove

6 mm
0.5 - 3 mm

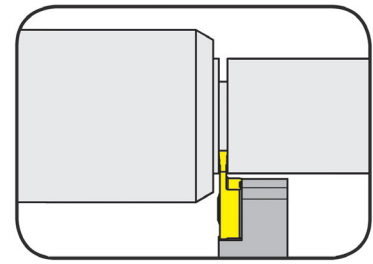

for Indexable insert

Type S274

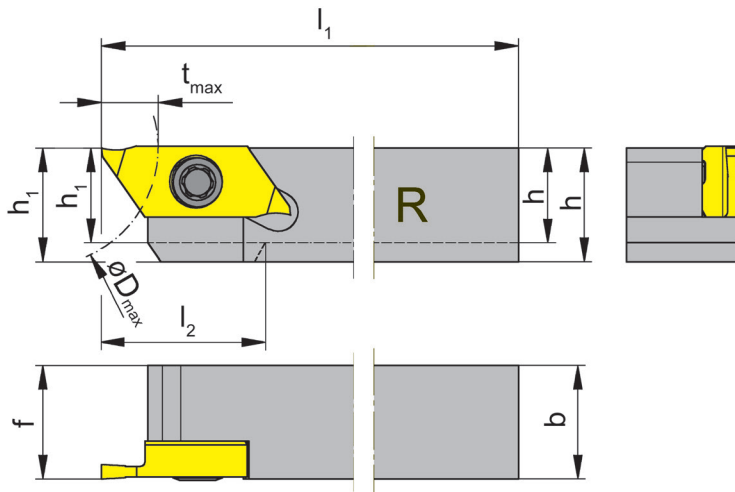

R = right hand version shown

L = left hand version

Part number	h	b	l ₁	l ₂	h ₁	f	t _{max}	D _{max}	Size
R/LH274.0808.04	8	8	100	16	8	8	6	25	04
R/LH274.1010.04	10	10	100	-	10	10	6	25	04
R/LH274.1212.04	12	12	100	-	12	12	6	25	04
R/LH274.1414.04	14	14	100	-	14	14	6	25	04
R/LH274.1616.04	16	16	125	-	16	16	6	25	04
R/LH274.2020.04	20	20	125	-	20	20	6	25	04

State R or L version

Dimensions in mm

Further sizes upon request

For torque specification of the screw, please see Technical Instructions.

Spare Parts

Toolholder	Clamping Screw	TORX PLUS® Wrench
R/LH274.0808.04	030.350P.0744	T15PQ
R/LH274...	030.3509.T15P	T15PQ



Indexable insert

S274

Depth of groove up to $.236''$
 Width of groove $.031 - .079''$

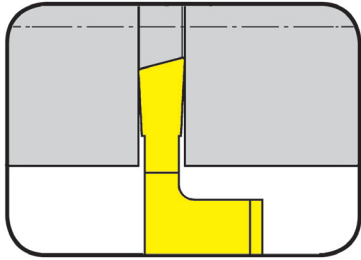

precision ground

for Toolholder

Type H274

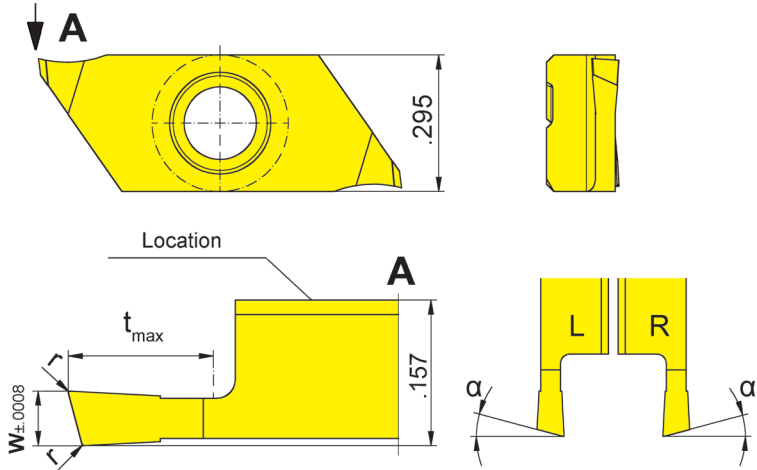

R = right hand version shown

L = left hand version

Indexability length $\pm .0006''$

Part number	w	r	t _{max}	α	Size	IG35	TH35
R/LS274.1508.03.10	.031	.002	.118	15°	04	▲/▲	▲/▲
R/LS274.1510.03.10	.039	.002	.118	15°	04	▲/▲	▲/▲
R/LS274.1515.04.10	.059	.002	.157	15°	04	▲/▲	▲/▲
R/LS274.1520.06.10	.079	.002	.236	15°	04	▲/▲	▲/▲

▲ on stock Δ 4 weeks x upon request

- recommended
- alternative recommendation
- not suitable

- uncoated grades
- coated grades
- brazed/Cermet

Dimensions in inch

State R or L version

Note:

t_{max} .236" can be reached only with workpiece $\varnothing \leq .984''$.

	IG35	TH35
P	-	●
M	●	●
K	-	●
N	-	●
S	●	●
H	-	-

Carbide grades



Indexable insert

S274

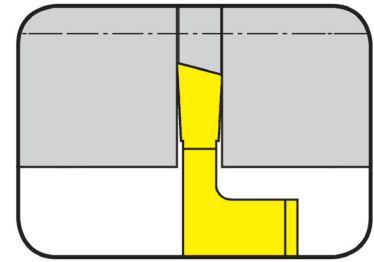

Depth of groove up to	.236"
Width of groove	.031 - .079"

precision ground

for Toolholder

Type H274

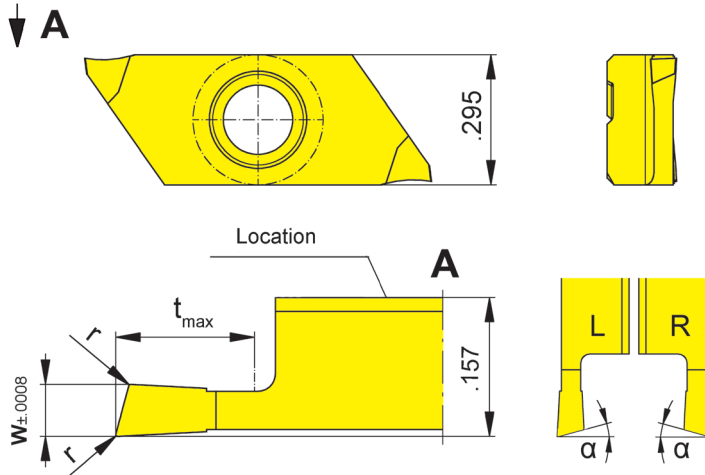

R = right hand version shown

L = left hand version

Indexability length \pm .0006"

Part number	w	r	t _{max}	α	Size	IG35	TH35
LS274.1508.03.10R	.031	.002	.118	15°	04	▲	▲
LS274.1510.03.10R	.039	.002	.118	15°	04	▲	▲
LS274.1515.04.10R	.059	.002	.157	15°	04	▲	▲
LS274.1520.06.10R	.079	.002	.236	15°	04	▲	▲
RS274.1508.03.10L	.031	.002	.118	15°	04	△	▲
RS274.1510.03.10L	.039	.002	.118	15°	04	△	▲
RS274.1515.04.10L	.059	.002	.157	15°	04	△	▲
RS274.1520.06.10L	.079	.002	.236	15°	04	△	▲

- ▲ on stock △ 4 weeks x upon request
- recommended
- alternative recommendation
- not suitable
- uncoated grades
- coated grades
- brazed/Cermet

Dimensions in inch

State R or L version

Note:

t_{max} .236" can be reached only with workpiece $\varnothing \leq .984$ ".

	IG35	TH35
P	-	●
M	●	●
K	-	●
N	-	●
S	●	●
H	-	-

Carbide grades

Indexable insert

S274

Depth of groove up to $.236''$
 Width of groove $.059 - .079''$

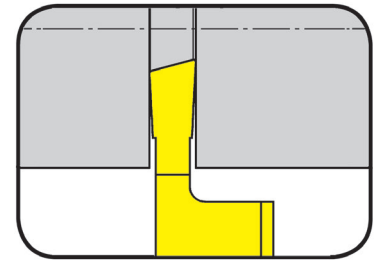

precision ground

for Toolholder

Type H274

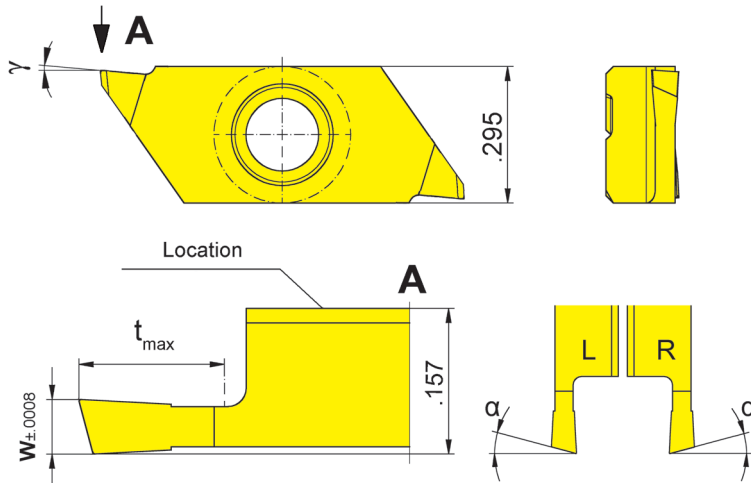

R = right hand version shown

L = left hand version

Indexability length $\pm .0006''$

Part number	w	t _{max}	α	γ	Size	IG35	TH35
R/LS274.1515.04.20	.059	.157	15°	5°	04	Δ/Δ	▲/▲
R/LS274.1520.06.20	.079	.236	15°	5°	04	Δ/Δ	▲/▲

- ▲ on stock Δ 4 weeks x upon request
 - recommended
 - o alternative recommendation
 - not suitable
 - uncoated grades
 - coated grades
 - brazed/Cermet
- Dimensions in inch

	IG35	TH35
P	-	●
M	●	●
K	-	●
N	-	●
S	●	●
H	-	-

Carbide grades

State R or L version

Note:

t_{max} .236'' can be reached only with workpiece $\varnothing \leq .984''$.



Indexable insert

S274

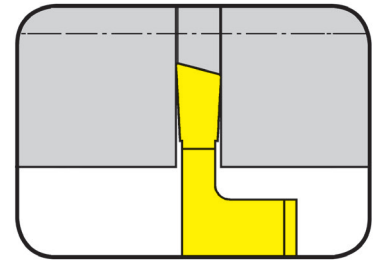

Depth of groove up to $.236''$
 Width of groove $.059 - .079''$

precision ground

for Toolholder

Type H274

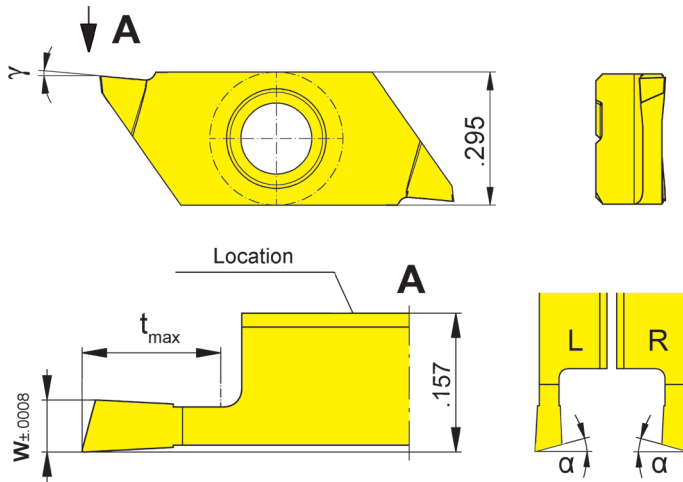

R = right hand version shown

L = left hand version

Indexability length $\pm .0006''$

Part number	w	t _{max}	α	γ	Size	Carbide grades	
						IG35	TH35
LS274.1515.04.20R	.059	.157	15°	5°	04	Δ	▲
LS274.1520.06.20R	.079	.236	15°	5°	04	Δ	▲
RS274.1515.04.20L	.059	.157	15°	5°	04	Δ	▲
RS274.1520.06.20L	.079	.236	15°	5°	04	Δ	▲

▲ on stock Δ 4 weeks x upon request
 ● recommended
 ○ alternative recommendation
 - not suitable

□ uncoated grades
 ■ coated grades
 ■ brazed/Cermet

Dimensions in inch

State R or L version

Note:

t_{max} = .236'' can be reached only with workpiece Ø ≤ .984''

	IG35	TH35
P	-	●
M	●	●
K	-	●
N	-	●
S	●	●
H	-	-

Carbide grades

U

Indexable insert

S274

Depth of groove up to $.236''$
 Width of groove $.031 - .079''$

precision ground

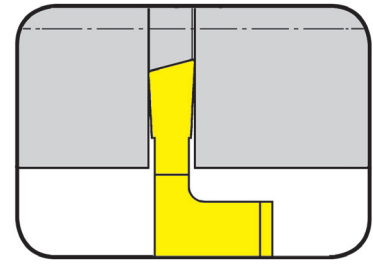

for Toolholder

Type H274

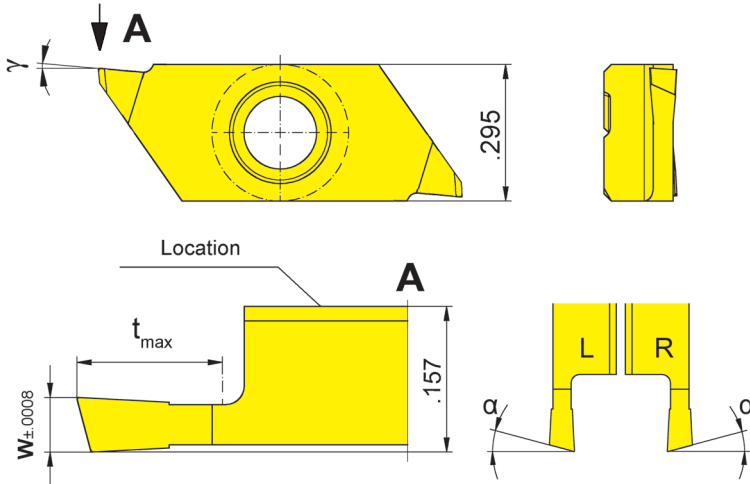

R = right hand version shown

L = left hand version

Indexability length $\pm .0006''$

Part number	w	t _{max}	α	γ	Size	IG35	TH35
R/LS274.1508.03.M0	.031	.118	15°	0°	04	Δ/Δ	▲/▲
R/LS274.1510.03.M0	.039	.118	15°	0°	04	Δ/Δ	▲/▲
R/LS274.1515.04.M0	.059	.157	15°	0°	04	Δ/Δ	▲/▲
R/LS274.1520.06.M0	.079	.236	15°	0°	04	Δ/Δ	▲/▲

▲ on stock Δ 4 weeks x upon request

- recommended
- alternative recommendation
- not suitable

- uncoated grades
- coated grades
- brazed/Cermet

Dimensions in inch

State R or L version

Note:

t_{max} = .236" can be reached only with workpiece Ø ≤ .984"

	IG35	TH35
P	-	●
M	●	●
K	-	●
N	-	●
S	●	●
H	-	-

Carbide grades



Indexable insert

S274

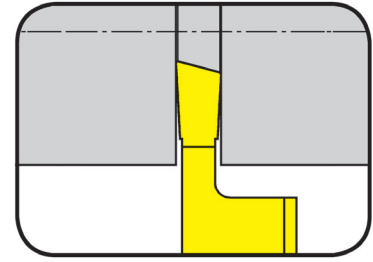

Depth of groove up to $.236''$
 Width of groove $.031 - .079''$

precision ground

for Toolholder

Type H274

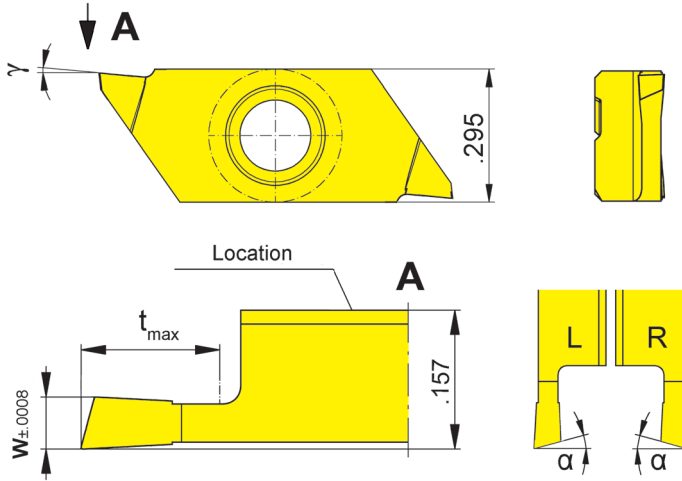

R = right hand version shown

L = left hand version

Indexability length $\pm .0006''$

Part number	w	t _{max}	α	γ	Size	IG35	TH35
LS274.1508.03.M0R	.031	.118	15°	0°	04	Δ	▲
LS274.1510.03.M0R	.039	.118	15°	0°	04	Δ	▲
LS274.1515.04.M0R	.059	.157	15°	0°	04	Δ	▲
LS274.1520.06.M0R	.079	.236	15°	0°	04	Δ	▲
RS274.1508.03.M0L	.031	.118	15°	0°	04	Δ	▲
RS274.1510.03.M0L	.039	.118	15°	0°	04	Δ	▲
RS274.1515.04.M0L	.059	.157	15°	0°	04	Δ	▲
RS274.1520.06.M0L	.079	.236	15°	0°	04	Δ	▲

- ▲ on stock Δ 4 weeks x upon request
- recommended
- alternative recommendation
- not suitable
- uncoated grades
- coated grades
- brazed/Cermet

Dimensions in inch

State R or L version

Note:

t_{max} .236'' can be reached only with workpiece $\varnothing \leq .984''$.

	P	M	K	N	S	H
IG35	-	●	-	-	●	-
TH35	●	●	●	●	●	-

Carbide grades

Toolholder

H274...E

Depth of groove
Width of groove

6 mm
0.5 - 3 mm

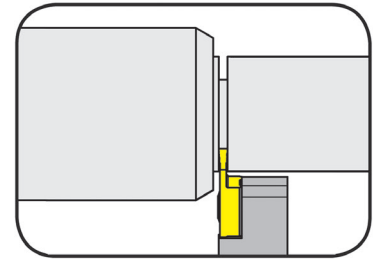

for Indexable insert

Type S274...E

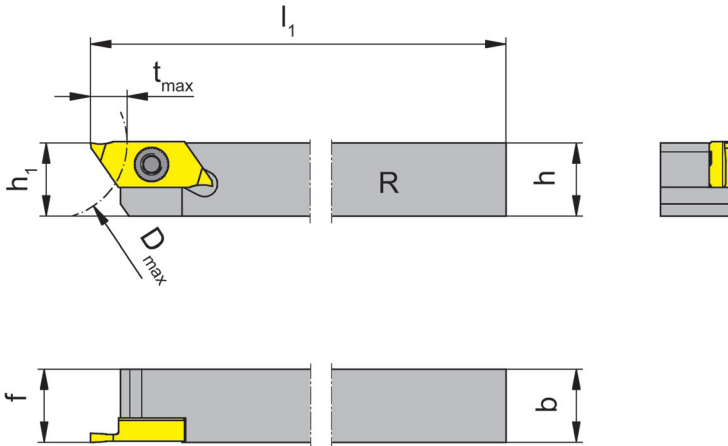

R = right hand version shown

L = left hand version

Part number	h	b	l ₁	h ₁	f	t _{max}	D _{max}	Size
R/LH274.1010.04.E	10	10	100	10	10	6	25	04
R/LH274.1212.04.E	12	12	100	12	12	6	25	04
R/LH274.1616.04.E	16	16	125	16	16	6	25	04
R/LH274.2020.04.E	20	20	125	20	20	6	25	04

State R or L version

Dimensions in mm

Further sizes upon request

For torque specification of the screw, please see Technical Instructions.

Spare Parts

Toolholder	Clamping Screw	TORX PLUS® Wrench
R/LH274...	030.3509.T15P	T15PQ



Indexable insert

S274...E

Depth of groove up to $.236''$
 Width of groove $.031 - .079''$

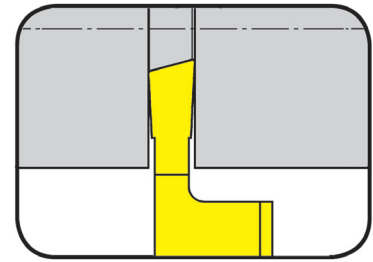

precision ground

for Toolholder

Type H274...E

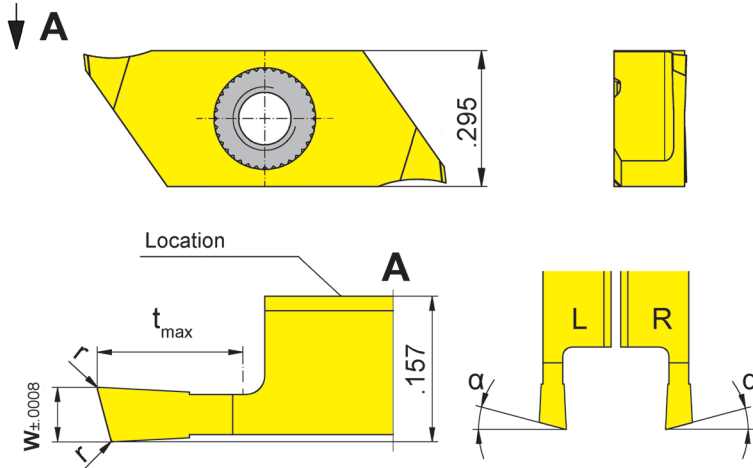

R = right hand version shown

L = left hand version

Indexability length $\pm .0006''$

Part number	w	r	t _{max}	α	Size	IG35	TH35
R/LS274.1508.03.10.E	.031	.002	.118	15°	04	ΔΔ	ΔΔ
R/LS274.1510.03.10.E	.039	.002	.118	15°	04	ΔΔ	ΔΔ
R/LS274.1515.04.10.E	.059	.002	.157	15°	04	ΔΔ	ΔΔ
R/LS274.1520.06.10.E	.079	.002	.236	15°	04	ΔΔ	ΔΔ

▲ on stock Δ 4 weeks x upon request

- recommended
- alternative recommendation
- not suitable

- uncoated grades
- coated grades
- brazed/Cermet

Dimensions in inch

State R or L version

Note:

t_{max} .236" can be reached only with workpiece $\varnothing \leq .984''$.

	IG35	TH35
P	-	•
M	•	•
K	-	•
N	-	•
S	•	•
H	-	-

Carbide grades

Indexable insert

S274...E

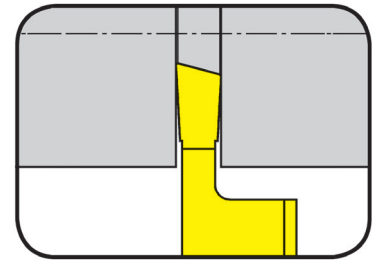

Depth of groove up to $.236''$
 Width of groove $.031 - .079''$

precision ground

for Toolholder

Type H274...E

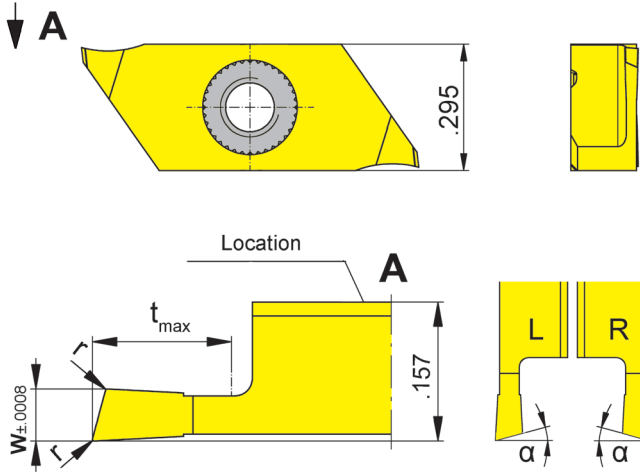

R = right hand version shown

L = left hand version

Indexability length $\pm .0006''$

Part number	w	r	t _{max}	α	Size	IG35	TH35
LS274.1508.03.1R.E	.031	.002	.118	15°	04	Δ	Δ
LS274.1510.03.1R.E	.039	.002	.118	15°	04	Δ	Δ
LS274.1515.04.1R.E	.059	.002	.157	15°	04	Δ	Δ
LS274.1520.06.1R.E	.079	.002	.236	15°	04	Δ	Δ
RS274.1508.03.1L.E	.031	.002	.118	15°	04	Δ	Δ
RS274.1510.03.1L.E	.039	.002	.118	15°	04	Δ	Δ
RS274.1515.04.1L.E	.059	.002	.157	15°	04	Δ	Δ
RS274.1520.06.1L.E	.079	.002	.236	15°	04	Δ	Δ

- ▲ on stock Δ 4 weeks x upon request
- recommended
- o alternative recommendation
- not suitable
- uncoated grades
- coated grades
- brazed/Cermet

Dimensions in inch

State R or L version

Note:

t_{max} .236'' can be reached only with workpiece $\varnothing \leq .984''$.

	P	M	K	N	S	H
IG35	-	●	-	-	●	-
TH35	●	●	●	●	●	-

Carbide grades



Indexable insert

S274...E

Depth of groove up to	.236"
Width of groove	.059 - .079"

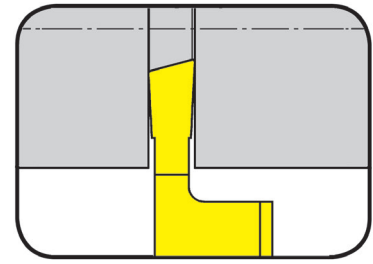

precision ground

for Toolholder

Type H274...E

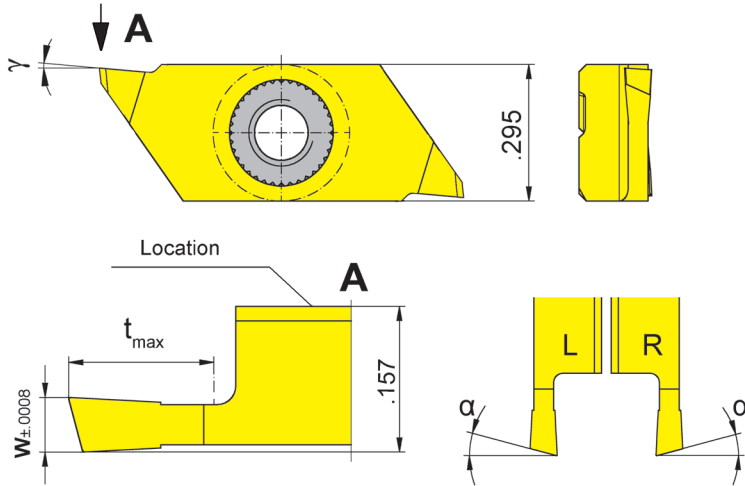

R = right hand version shown

L = left hand version

Indexability length ± .0006"

Part number	w	t _{max}	α	γ	Size	Carbide grades	
						IG35	TH35
R/LS274.1515.04.20.E	.059	.157	15°	5°	04	Δ/Δ	Δ/Δ
R/LS274.1520.06.20.E	.079	.236	15°	5°	04	Δ/Δ	Δ/Δ

▲ on stock Δ 4 weeks x upon request

- recommended
- alternative recommendation
- not suitable

- uncoated grades
- coated grades
- brazed/Cermet

Dimensions in inch

State R or L version

Note:

t_{max} .236" can be reached only with workpiece Ø ≤ .984".

	IG35	TH35
P	-	●
M	●	●
K	-	●
N	-	●
S	●	●
H	-	-

Carbide grades

U

Indexable insert

S274...E

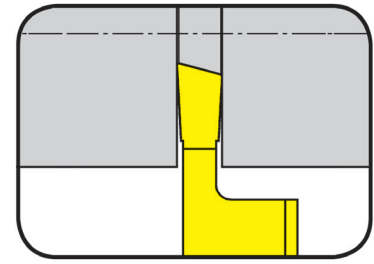

Depth of groove up to $.236''$
 Width of groove $.059 - .079''$

precision ground

for Toolholder

Type H274...E

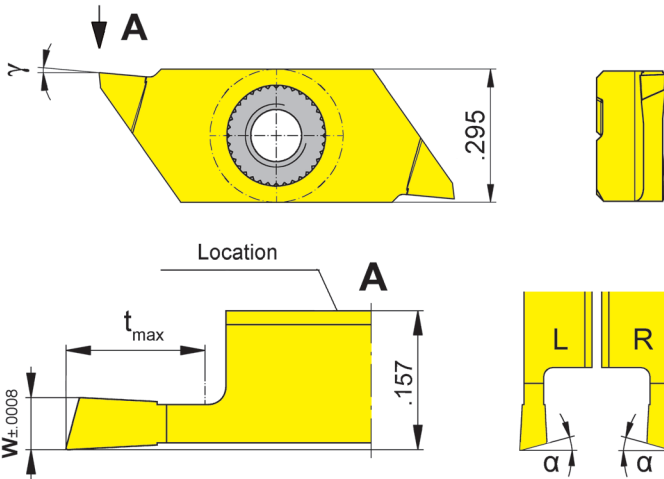

R = right hand version shown

L = left hand version

Indexability length $\pm .0006''$

Part number	w	t _{max}	α	γ	Size	IG35	TH35
LS274.1515.04.2R.E	.059	.157	15°	5°	04	Δ	Δ
LS274.1520.06.2R.E	.079	.236	15°	5°	04	Δ	Δ
RS274.1515.04.2L.E	.059	.157	15°	5°	04	Δ	Δ
RS274.1520.06.2L.E	.079	.236	15°	5°	04	Δ	Δ

▲ on stock Δ 4 weeks x upon request

- recommended
- alternative recommendation
- not suitable

- uncoated grades
- coated grades
- brazed/Cermet

Dimensions in inch

State R or L version

Note:

t_{max} $.236''$ can be reached only with workpiece $\varnothing \leq .984''$.

P	-	●
M	●	●
K	-	●
N	-	●
S	●	●
H	-	-

Carbide grades



Indexable insert

S274...E

Depth of groove up to $.236''$
 Width of groove $.031 - .079''$

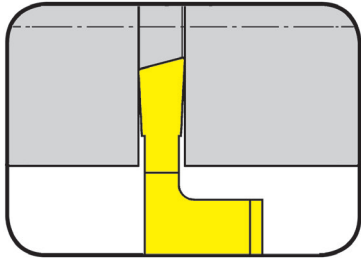

precision ground

for Toolholder

Type H274...E

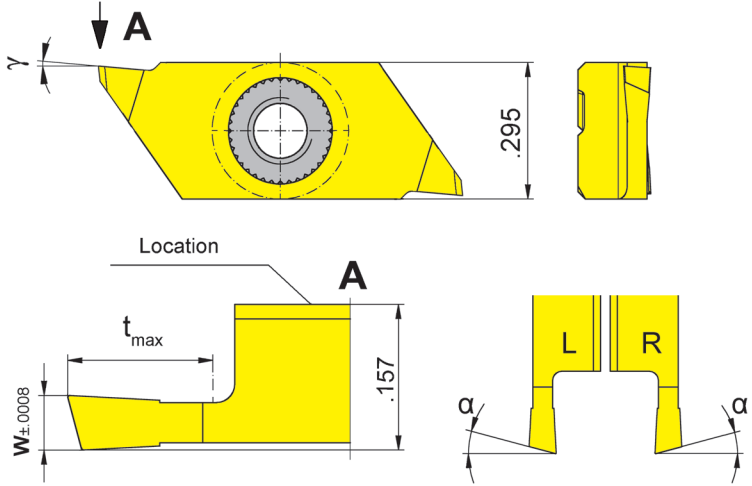

R = right hand version shown

L = left hand version
 Image Dimensions mm

Indexability length $\pm .0006''$

Part number	w	t _{max}	α	γ	Size	IG35	TH35
R/LS274.1508.03.M0.E	.031	.118	15°	0°	04	ΔΔ	ΔΔ
R/LS274.1510.03.M0.E	.039	.118	15°	0°	04	ΔΔ	ΔΔ
R/LS274.1515.04.M0.E	.059	.157	15°	0°	04	ΔΔ	ΔΔ
R/LS274.1520.06.M0.E	.079	.236	15°	0°	04	ΔΔ	ΔΔ

▲ on stock Δ 4 weeks x upon request

- recommended
- alternative recommendation
- not suitable

- uncoated grades
- coated grades
- brazed/Cermet

Dimensions in inch

State R or L version

Note:

t_{max} .236" can be reached only with workpiece $\varnothing \leq .984''$.

	IG35	TH35
P	-	●
M	●	●
K	-	●
N	-	●
S	●	●
H	-	-

Carbide grades

Indexable insert

S274...E

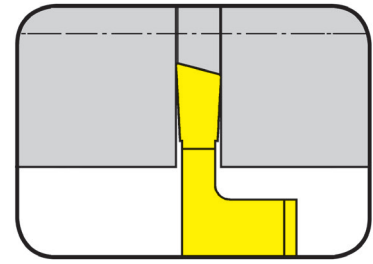

Depth of groove up to
Width of groove

.236"
.031 - .079"

precision ground

for Toolholder

Type H274...E

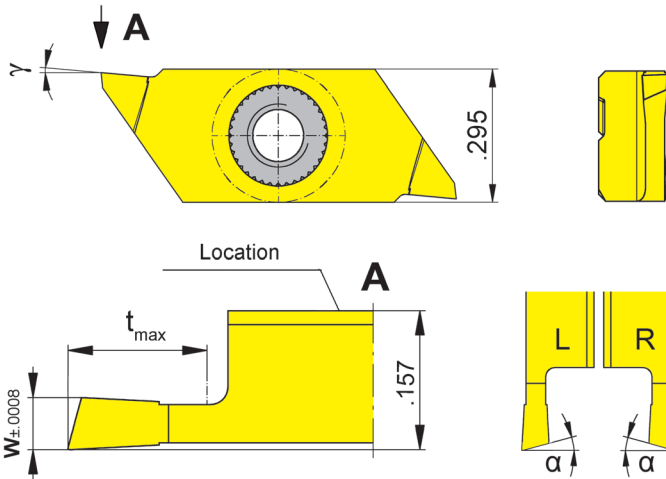

R = right hand version shown

L = left hand version
Image Dimensions mm

Indexability length \pm
.0006"

Part number	w	t _{max}	α	γ	Size	IG35	TH35
LS274.1508.03.MR.E	.031	.118	15°	0°	04	Δ	Δ
LS274.1510.03.MR.E	.039	.118	15°	0°	04	Δ	Δ
L/S274.1515.04.MR.E	.059	.157	15°	0°	04	Δ	Δ
LS274.1520.06.MR.E	.079	.236	15°	0°	04	Δ	Δ
R/S274.1508.03.ML.E	.031	.118	15°	0°	04	Δ	Δ
R/S274.1510.03.ML.E	.039	.118	15°	0°	04	Δ	Δ
R/S274.1515.04.ML.E	.059	.157	15°	0°	04	Δ	Δ
R/S274.1520.06.ML.E	.079	.236	15°	0°	04	Δ	Δ

▲ on stock Δ 4 weeks x upon request

● recommended
○ alternative recommendation
- not suitable

□ uncoated grades
■ coated grades
■ brazed/Cermet

Dimensions in inch

State R or L version

Note:

t_{max} .236" can be reached only with workpiece Ø ≤ .984".

	P	M	K	N	S	H
IG35	-	●	-	-	●	-
TH35	●	●	●	●	●	-

Carbide grades



Toolholder

218

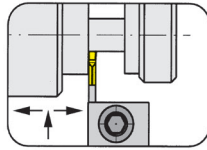

Page
U98-U101

Basic toolholder

226

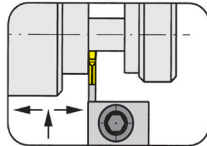

Page
U97

Indexable insert

S229/229

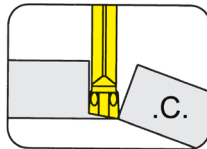

Page
U105 - U106

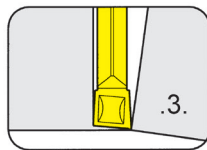

Page
U107

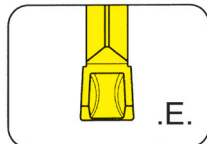

Page
U108

U

229



Toolholder with Inserts

Width of groove .118 - .197"

U

Grooving and Side Turning (external)



Toolholder

U218

Depth of groove up to
Clamping range

.709"
.098 - .240"

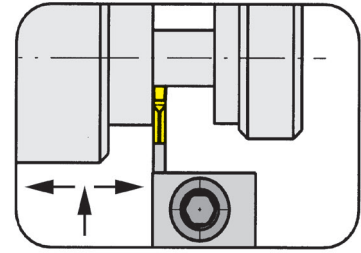

for Indexable insert

Type 229
S229
N229

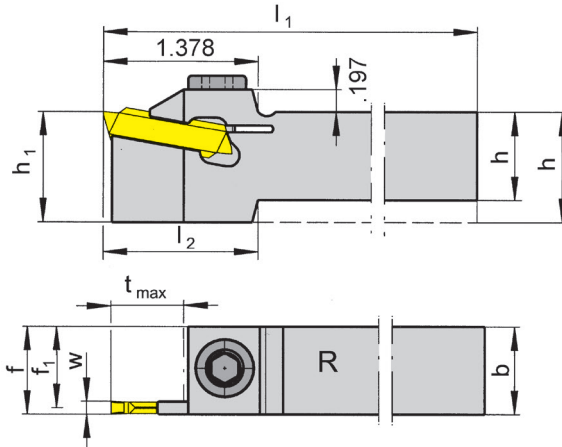

R = right hand version shown

L = left hand version

Part number	h	b	l ₁	l ₂	h ₁	f ₁	f	t _{max}	Size	Clamping range
R/LU218.0750.02	.750	.750	6.004	1.378	1.00	.693	f ₁ +w/2	.709	02	.098 - .118
R/LU218.1000.02	1.000	1.000	6.004	-	1.00	.943	f ₁ +w/2	.709	02	.098 - .118
R/LU218.0625.03	.625	.625	6.004	1.772	1.00	.567	f ₁ +w/2	.709	03	.118 - .157
R/LU218.0750.03	.750	.750	6.004	1.378	1.00	.693	f ₁ +w/2	.709	03	.118 - .157
R/LU218.1000.03	1.000	1.000	6.004	-	1.00	.943	f ₁ +w/2	.709	03	.118 - .157
R/LU218.1250.03	1.250	1.000	6.693	-	1.25	.943	f ₁ +w/2	.709	03	.118 - .157
R/LU218.0750.04	.750	.750	6.004	1.378	1.00	.659	f ₁ +w/2	.709	04	.157 - .200
R/LU218.1000.04	1.000	1.000	6.004	-	1.00	.909	f ₁ +w/2	.709	04	.157 - .200
R/LU218.1250.04	1.250	1.250	6.004	-	1.25	1.159	f ₁ +w/2	.709	04	.157 - .200
R/LU218.0750.05	.750	.750	6.004	1.378	1.00	.640	f ₁ +w/2	.709	05	.201 - .236
R/LU218.1000.05	1.000	1.000	6.004	-	1.00	.890	f ₁ +w/2	.709	05	.201 - .240
R/LU218.1250.05	1.250	1.000	6.693	-	1.25	.890	f ₁ +w/2	.709	05	.201 - .240

State R or L version

w see indexable inserts

Dimensions in inch

R/LU218...02 max. depth of groove up to Ø 3.150"

Further sizes upon request

For torque specification of the screw, please see Technical Instructions.

Spare Parts

Toolholder	Clamping Screw	Allen wrench
R/LU218...	218.3	SW6,0 DIN911

Toolholder

218

Depth of groove up to 18 mm
Clamping range 3 - 5 mm

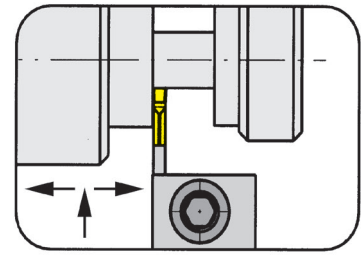

for Indexable insert

Type S229

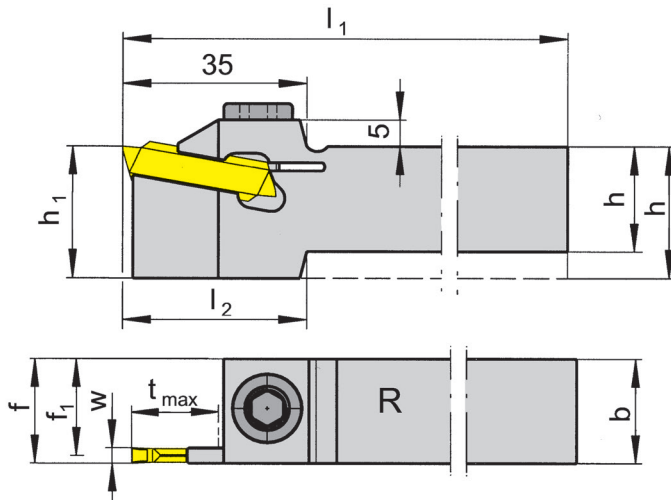

R = right hand version shown

L = left hand version

Part number	h	b	l ₁	l ₂	h ₁	f ₁	f	t _{max}	Size	Clamping range
R/L218.1616.03	16	16	150	45	25	14.55	f ₁ +w/2	18	03	3 - 4
R/L218.2020.03	20	20	150	35	25	18.55	f ₁ +w/2	18	03	3 - 4
R/L218.2525.03	25	25	150	-	25	23.55	f ₁ +w/2	18	03	3 - 4
R/L218.3225.03	32	25	170	-	32	23.55	f ₁ +w/2	18	03	3 - 4
R/L218.2020.04	20	20	150	35	25	17.70	f ₁ +w/2	18	04	4 - 5
R/L218.2525.04	25	25	150	-	25	22.70	f ₁ +w/2	18	04	4 - 5
R/L218.3225.04	32	25	170	-	32	22.70	f ₁ +w/2	18	04	4 - 5

State R or L version

w see indexable inserts

Dimensions in mm

Further sizes upon request

For torque specification of the screw, please see Technical Instructions.

Parting Off solid Bars

Parting Off tubes

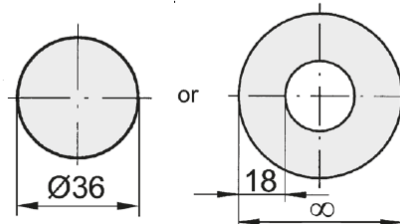

Spare Parts

Toolholder	Clamping Screw	Allen wrench
R/L218...	218.3	SW6,0 DIN911



Basic toolholder

U218

with changeable cassette

Depth of groove up to
Clamping range

.709"
.118 - .319"

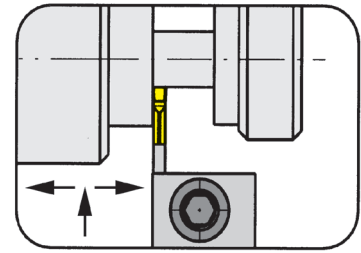

Indexable insert

Type 229
S229
N229

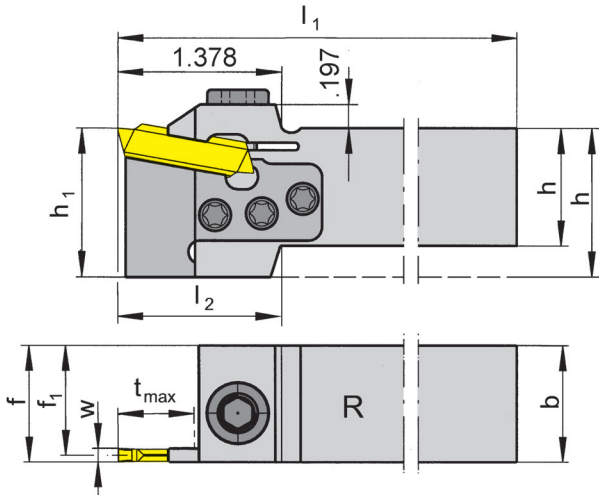

R = right hand version shown

L = left hand version

Part number	h	b	l ₁	l ₂	h ₁	f ₁	f	t _{max}	Size	Clamping range
R/LU218.1000.K3	1.000	1.000	6.004	1.378	1.260	.943	f ₁ +w/2	.709	03	.118 - .157
R/LU218.1250.K3	1.250	1.000	6.693	1.378	1.260	.943	f ₁ +w/2	.709	03	.118 - .157
R/LU218.1000.K4	1.000	1.000	6.004	1.378	1.260	.909	f ₁ +w/2	.709	04	.157 - .197
R/LU218.1250.K4	1.250	1.000	6.693	-	1.250	.909	f ₁ +w/2	.709	04	.157 - .200
R/LU218.1000.K5	1.000	1.000	6.004	1.378	1.260	.890	f ₁ +w/2	.709	05	.201 - .240
R/LU218.1250.K5	1.250	1.000	6.693	1.378	1.260	.890	f ₁ +w/2	.709	05	.201 - .240
R/LU218.1000.K7	1.000	1.000	6.004	1.378	1.260	.850	f ₁ +w/2	.709	07	.240 - .319
R/LU218.1250.K7	1.250	1.000	6.693	-	1.250	.850	f ₁ +w/2	.709	07	.240 - .319

State R or L version

w see indexable inserts

Dimensions in inch

Further sizes upon request

For torque specification of the screw, please see Technical Instructions.

Spare Parts

Basic toolholder	Clamping Screw	Allen wrench	Cassette	TORX PLUS® Wrench
R/LU218...K3	030.0518.T20P	SW6,0 DIN911	NK218.32.03	T20PQ
R/LU218...K4	030.0518.T20P	SW6,0 DIN911	NK218.32.04	T20PQ
R/LU218...K5	030.0518.T20P	SW6,0 DIN911	NK218.32.05	T20PQ
R/LU218...K6	030.0518.T20P	SW6,0 DIN911	NK218.32.07	T20PQ

Basic toolholder

218

with changeable cassette

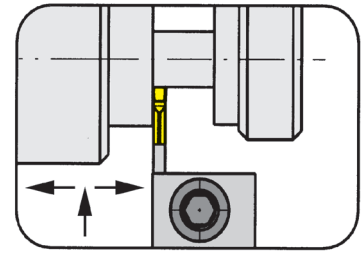

Depth of groove up to 18 mm
Clamping range 3 - 5 mm

for Indexable insert

Type S229

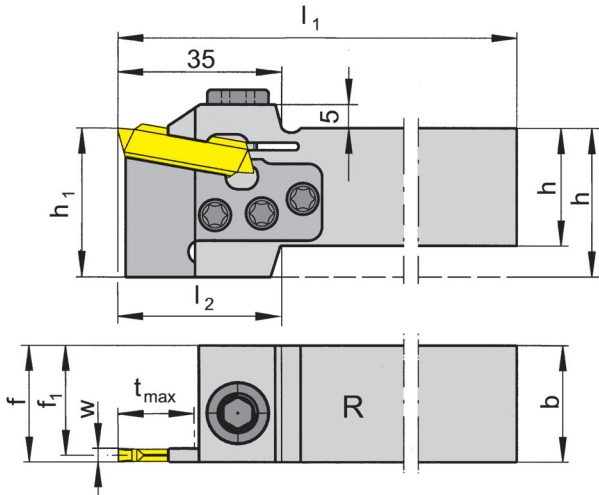

R = right hand version shown

L = left hand version

Part number	h	b	l ₁	l ₂	h ₁	f ₁	f	t _{max}	Size	Clamping range
R/L218.2525.K3	25	25	150	35	32	23.55	f ₁ +w/2	18	03	3 - 4
R/L218.3225.K3	32	25	170	-	32	23.55	f ₁ +w/2	18	03	3 - 4
R/L218.2525.K4	25	25	150	35	32	22.70	f ₁ +w/2	18	04	4 - 5
R/L218.3225.K4	32	25	170	-	32	22.70	f ₁ +w/2	18	04	4 - 5

State R or L version

w see indexable inserts

Dimensions in mm

Further sizes upon request

For torque specification of the screw, please see Technical Instructions.

Parting Off solid Bars Parting Off tubes

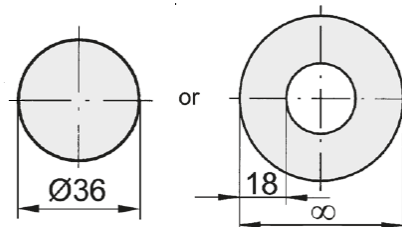

Spare Parts

Basic toolholder	Clamping Screw	Allen wrench	Cassette	TORX PLUS® Wrench	Torx Wrench
R/L218...K3	030.0518.T20P	SW6,0 DIN911	NK218.32.03	T20PQ	
R/L218...K4	030.0518.T20P	SW6,0 DIN911	NK218.32.04	T20PQ	



Toolholder

U226

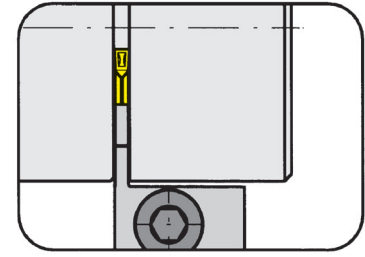

Depth of groove up to $1''$
Clamping range $.118 - .236''$

for Indexable insert

Type 229
S229
N229

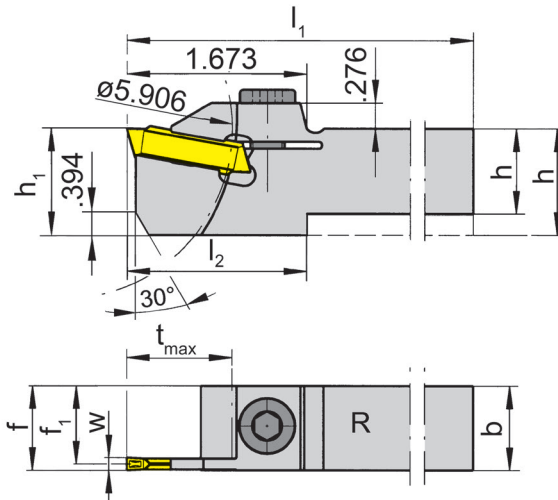

R = right hand version shown

L = left hand version

Part number	h	b	l ₁	l ₂	h ₁	f ₁	f	t _{max}	Size	Clamping range
R/LU226.0625.03	.625	.625	6.004	2.000	1.250	.568	f ₁ +w/2	1.000	03	.118 - .157
R/LU226.0750.03	.750	.750	6.004	1.673	1.250	.693	f ₁ +w/2	1.000	03	.118 - .157
R/LU226.1000.03	1.000	1.000	6.004	1.673	1.250	.943	f ₁ +w/2	1.000	03	.118 - .157
R/LU226.1250.03	1.250	1.000	6.693	-	1.250	.943	f ₁ +w/2	1.000	03	.118 - .157
R/LU226.0625.04	.625	.625	6.004	2.000	1.250	.534	f ₁ +w/2	1.000	04	.157 - .200
R/LU226.0750.04	.750	.750	6.004	1.673	1.250	.659	f ₁ +w/2	1.000	04	.157 - .200
R/LU226.1000.04	1.000	1.000	6.004	1.673	1.260	.909	f ₁ +w/2	.984	04	.157 - .200
R/LU226.1250.04	1.250	1.000	6.693	-	1.250	.909	f ₁ +w/2	1.000	04	.157 - .197
R/LU226.0750.05	.750	.750	6.004	1.673	1.260	.640	f ₁ +w/2	.984	05	.201 - .236
R/LU226.1000.05	1.000	1.000	6.004	1.673	1.250	.890	f ₁ +w/2	1.000	05	.201 - .236
R/LU226.1250.05	1.250	1.000	6.693	-	1.250	.890	f ₁ +w/2	.984	05	.201 - .236

State R or L version

w see indexable inserts

Dimensions in inch

Further sizes upon request

For torque specification of the screw, please see Technical Instructions.

Spare Parts

Toolholder	Clamping Screw	Allen wrench
R/LU226...	218.3	SW6,0 DIN911

Toolholder

226

Depth of groove up to 25 mm
Clamping range 3 - 5 mm

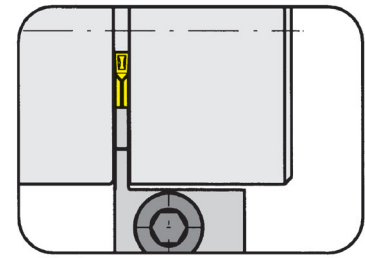

for Indexable insert

Type 229
S229
N229

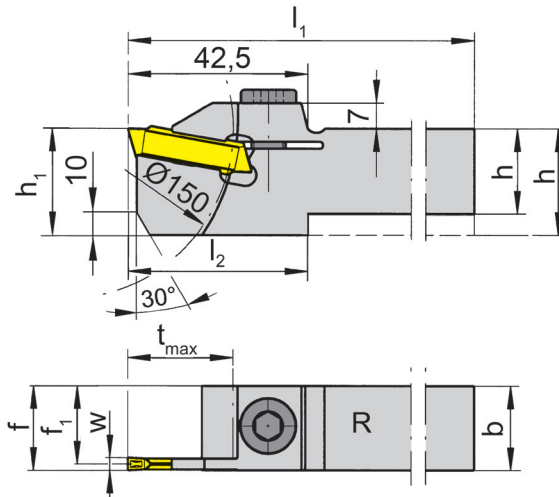

R = right hand version shown

L = left hand version

Part number	h	b	l ₁	l ₂	h ₁	f ₁	f	t _{max}	Size	Clamping range
R/L226.1616.03	16	16	150	52.5	32	18.55	f ₁ +w/2	25	03	3 - 4
R/L226.2020.03	20	20	150	42.5	32	18.55	f ₁ +w/2	25	03	3 - 4
R/L226.2525.03	25	25	150	-	32	23.55	f ₁ +w/2	25	03	3 - 4
R/L226.3225.03	32	25	170	-	32	23.55	f ₁ +w/2	25	03	3 - 4
R/L226.1616.04	16	16	150	52.5	32	13.70	f ₁ +w/2	25	04	4 - 5
R/L226.2020.04	20	20	150	42.5	32	17.70	f ₁ +w/2	25	04	4 - 5
R/L226.2525.04	25	25	150	-	32	22.70	f ₁ +w/2	25	04	4 - 5
R/L226.3225.04	32	25	170	-	32	22.70	f ₁ +w/2	25	04	4 - 5

State R or L version

w see indexable inserts

Dimensions in mm

Further sizes upon request

For torque specification of the screw, please see Technical Instructions.

Parting Off solid Bars

Parting Off tubes

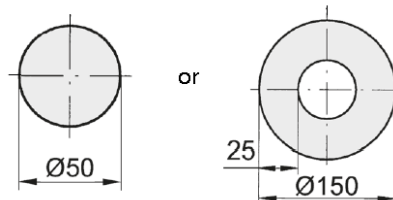

Spare Parts

Toolholder	Clamping Screw	Allen wrench
R/L226...	218.3	SW6,0 DIN911



Toolholder

226

reinforced version

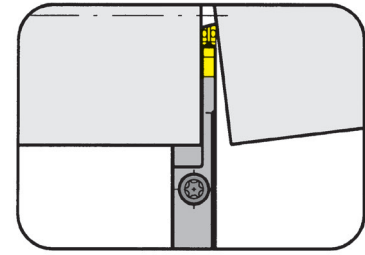

Depth of groove up to 25 mm
Clamping range 3 - 4 mm

for Indexable insert

Type S229

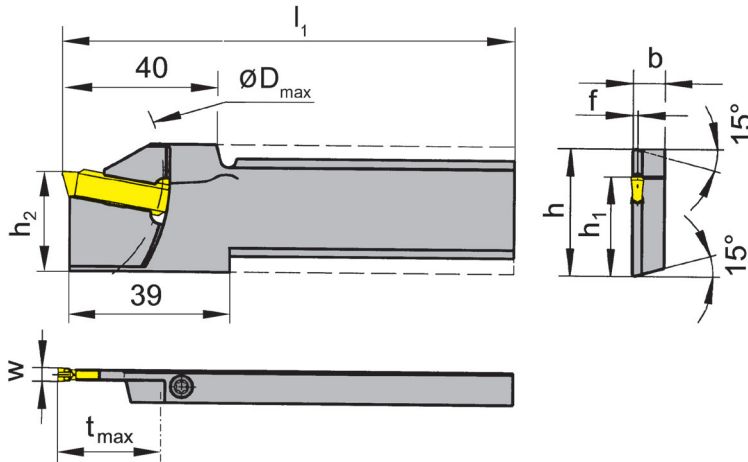

R = right hand version shown

L = left hand version

Part number	h	b	l ₁	h ₂	f	t _{max}	D _{max}	h ₁	Size	Clamping range
R/L226.2608.03	26	8	110	24.8	1.2	25	150	21.4	03	3
R/L226.3208.03	32	8	110	24.8	1.2	25	150	24.8	03	3
R/L226.2608.04	26	8	110	24.8	1.7	25	150	21.4	04	4
R/L226.3208.04	32	8	110	24.8	1.7	25	150	24.8	04	4

State R or L version

w see indexable inserts

Dimensions in mm

Further sizes upon request

For torque specification of the screw, please see Technical Instructions.

Parting Off solid Bars Parting Off tubes

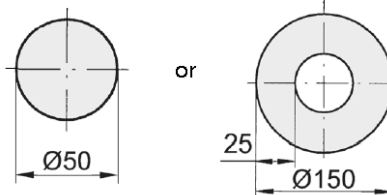

Spare Parts

Toolholder	Clamping Screw	TORX PLUS® Wrench
R/L226...	4.15T15P	T15PQ

Indexable insert

S229

with chip forming

Depth of groove up to
Width of groove

.984"
.118 - .157"

precision sintered

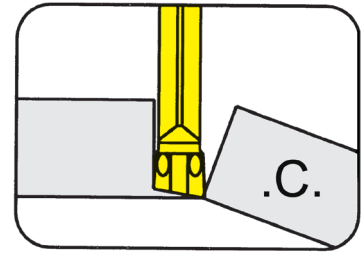

for Toolholder

Type 218
226

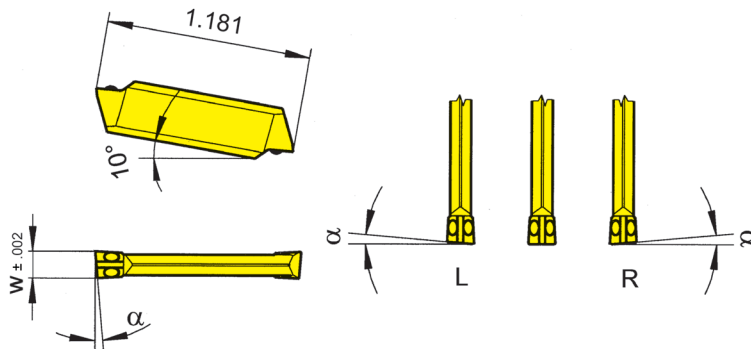

R = right hand version shown

L = left hand version

Indexability length ± .001"

Part number	w	α	Size	Carbide grades			
				TC92	TF45	TI25	TN35
R/LS229.0530.C0	.118	5°	03	x/x	▲/▲	▲/▲	▲/▲
R/LS229.0540.C0	.157	5°	03	x/x	x/x	Δ/x	▲/x
R/LS229.0830.C0	.118	8°	03	▲/▲	▲/▲	▲/▲	▲/▲
R/LS229.0840.C0	.157	8°	03	x/x	x/x	▲/x	▲/Δ
S229.0030.C0	.118	0°	03	x	▲	▲	▲
S229.0040.C0	.157	0°	03	x	x	▲	▲

▲ on stock Δ 4 weeks x upon request

● recommended

o alternative recommendation

- not suitable

□ uncoated grades

■ coated grades

■ brazed/Cermet

Dimensions in inch

State R or L version

Indexable inserts can be used in right and left hand toolholders.

P	●	●	●	●
M	-	●	●	●
K	-	●	●	●
N	-	●	●	●
S	-	●	●	●
H	-	-	-	-

Carbide grades

Indexable insert

S229

with chip forming

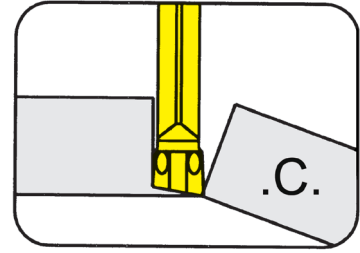

Depth of groove up to	.984"
Width of groove	.118 - .157"

precision sintered

for Toolholder

Type 218
226

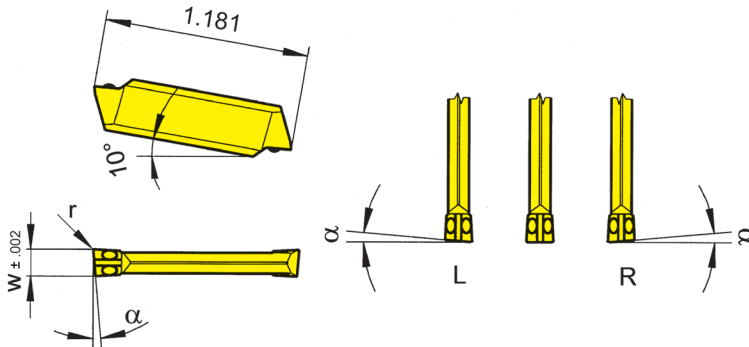

R = right hand version shown

L = left hand version

Indexability length ± .001"

Part number	w	r	α	Size	Carbide grades			
					TC92	TF45	TI25	TN35
R/LS229.0530.C1	.118	.006	5°	03	x/x	x/x	▲/▲	▲/▲
R/LS229.0830.C1	.118	.006	8°	03	x/x	▲/▲	▲/Δ	▲/▲
S229.0030.C1	.118	.006	0°	03	x	▲	▲	▲
R/LS229.0540.C1	.157	.006	5°	04	x/x	x/x	Δ/x	Δ/x
R/LS229.0840.C1	.157	.006	8°	04	x/x	x/x	x/x	▲/Δ
S229.0040.C1	.157	.006	0°	04	x	Δ	Δ	x

▲ on stock Δ 4 weeks x upon request

- recommended
- alternative recommendation
- not suitable

- uncoated grades
- coated grades
- brazed/Cermet

Dimensions in inch

State R or L version

Indexable inserts can be used in right and left hand toolholders.

	P	M	K	N	S	H
TC92	●	-	-	-	-	-
TF45	●	●	●	●	●	-
TI25	●	●	●	●	●	-
TN35	●	●	●	●	●	-

Carbide grades

Indexable insert

229/S229

with chip former

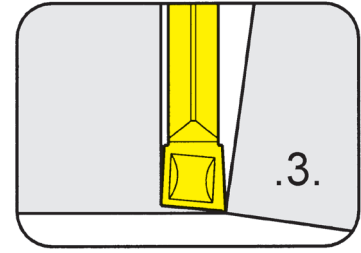

Depth of groove up to .984"
Width of groove .118 - .157"

precision sintered

for Toolholder

Type 218
226

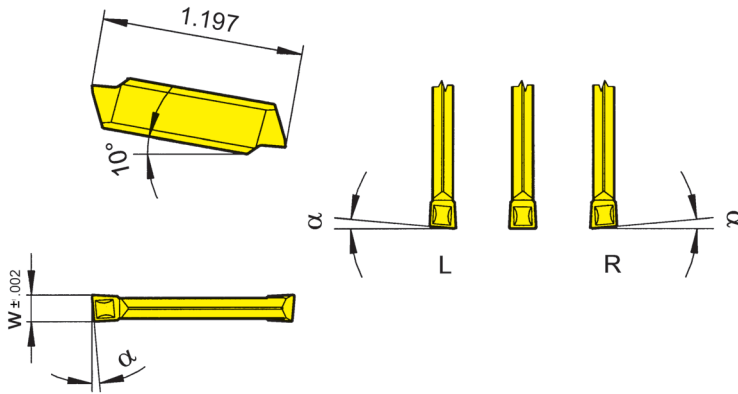

R = right hand version shown

L = left hand version

Indexability length ± .002"

Part number	w	r	α	Size	Carbide grades													
					MG12	P20	AL96	AS62	AS66	H54	TA45	TC92	TF45	TI22	TI25	TN32	TN35	
R/L229.5300.31	.118	.008	5°	03	▲/▲				▲/▲				Δ/Δ			▲/▲	▲/▲	▲/▲
R/LS229.0530.32	.118	.008	5°	03				▲/▲				x/x	Δ/Δ	▲/▲		▲/▲	▲/▲	▲/▲
S229.0300.32	.118	.008	-	03	▲	x	▲	▲	▲	▲	x	Δ	▲	▲	▲	▲	▲	▲
R/LS229.0540.32	.157	.008	5°	04				▲/▲			x/x	x/x	▲/▲		▲/▲	▲/▲	▲/▲	x/x
S229.0400.32	.157	.008	-	04	x	x	▲	▲	▲	▲	x	Δ	▲	x	▲	▲	▲	▲
					P	o	•	•	•	•	•	•	•	•	•	•	•	•
					M	-	-	-	-	o	•	•	-	-	•	-	-	•
					K	-	-	•	-	•	-	•	-	•	-	•	-	•
					N	-	-	•	-	•	-	•	-	•	-	•	-	•
					S	-	-	-	-	o	-	•	-	•	-	•	-	•
					H	-	-	-	-	-	-	-	-	-	-	-	-	-

Dimensions in inch

Carbide grades

State R or L version

Note:

R/L229.5300.31 precision ground, length 1.181"

Indexable inserts can be used in right and left hand toolholders.



Indexable insert

S229

with chip forming

Depth of groove up to
Width of groove

.984"
.118 - .157"

precision sintered

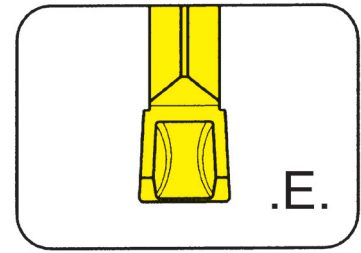

for Toolholder

Type 218
226

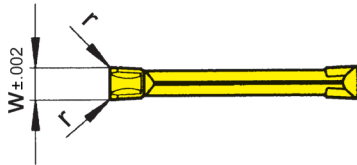
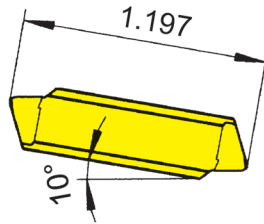

Indexability length $\pm .002''$

Part number	w	r	Size	Carbide grades				
				AS62	TC92	TF45	TF46	TI25
S229.0300.E2	.118	.008	03	▲	x	▲	▲	▲
S229.0300.E4	.118	.016	03	▲	x	▲		
S229.0400.E2	.157	.008	04	▲	x	▲	x	▲
S229.0400.E4	.157	.016	04	▲	x	▲		
P	•	•	•	•	•	•	•	•
M	-	-	•	o	•			
K	-	-	•	•	•			
N	-	-	•	•	•			
S	-	-	•	o	•			
H	-	-	-	-	-			

▲ on stock Δ 4 weeks x upon request

● recommended

o alternative recommendation

- not suitable

□ uncoated grades

■ coated grades

■ brazed/Cermet

Dimensions in inch

Carbide grades

Indexable inserts can be used in right and left hand toolholders.

U

Indexable insert

S229

with chip forming

Depth of groove up to
Width of groove

.984"
.118 - .157"

precision sintered

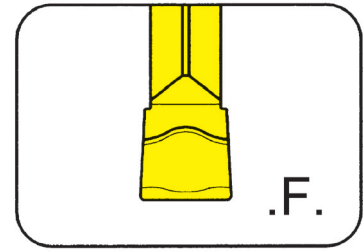

for Toolholder

Type 218
226

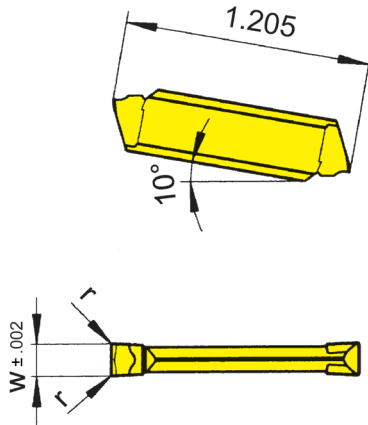

Indexability length $\pm .002''$

Part number	w	r	Size	TC92	TF43	TF45	TF46	TI22	TI25
S229.0300.F2	.118	.008	03	x	▲	▲	▲	▲	x
S229.0300.F4	.118	.016	03	x		▲	x		x
S229.0400.F2	.157	.008	04	x	x	▲	▲		x
S229.0400.F4	.157	.016	04	x		▲	x		x
				P	•	•	•	•	•
				M	-	-	o	-	•
				K	-	-	•	-	•
				N	-	-	•	-	•
				S	-	-	o	-	•
				H	-	-	-	-	-

Carbide grades

▲ on stock Δ 4 weeks x upon request

• recommended

o alternative recommendation

- not suitable

□ uncoated grades

■ coated grades

■ brazed/Cermet

Dimensions in inch

Indexable inserts can be used in right and left hand toolholders.



Indexable insert

S229

with chip forming

Depth of groove up to
Width of groove

.984"
.118 - .197"

precision sintered

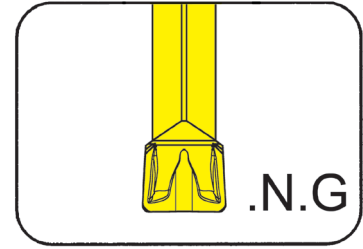

for Toolholder

Type 218
226

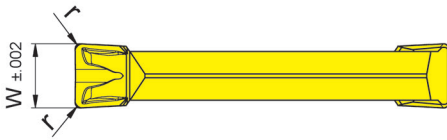
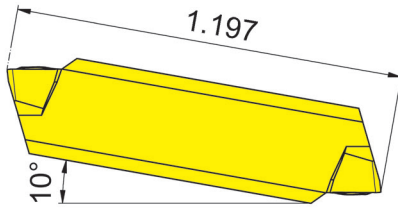

Indexability length $\pm .002''$

Part number	w	r	Size	Carbide grades				
				AS45	AS62	DD25	TI25	
S229.0300.N2.G	.118	.008	03	▲				
S229.0300.N4.G	.118	.016	03	▲				
S229.0400.N2.G	.157	.008	04	▲				
S229.0400.N4.G	.157	.016	04	▲				
S229.0500.N2.G	.197	.008	04			x	▲	
S229.0500.N4.G	.197	.016	04	▲	▲	x	▲	
S229.0500.N6.G	.197	.024	04	▲	▲		▲	
S229.0500.N8.G	.197	.031	04		▲			
				P	•	•	-	•
				M	•	-	-	•
				K	•	-	-	•
				N	o	-	•	•
				S	•	-	o	•
				H	-	-	-	-

▲ on stock Δ 4 weeks x upon request
 ● recommended
 o alternative recommendation
 - not suitable
 □ uncoated grades
 ■ coated grades
 ■ brazed/Cermet

Dimensions in inch

Carbide grades

Indexable inserts can be used in right and left hand toolholders.



U

Toolholder

360/368/391

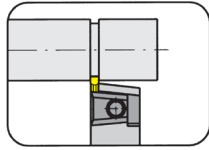

Page
U114-U115

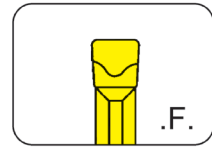

Page
U127

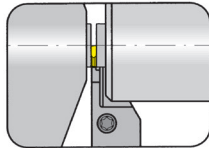

Page
U116

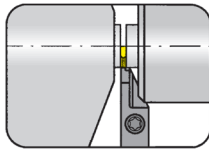

Page
U117-U118

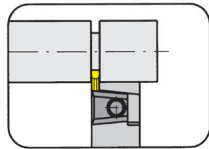

Page
U119

Indexable insert

312/S312

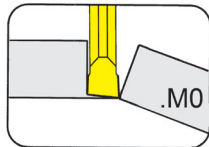

Page
U120

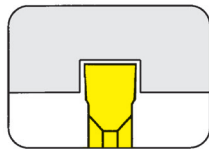

Page
U123

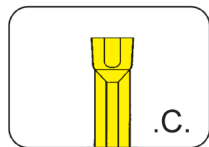

Page
U125

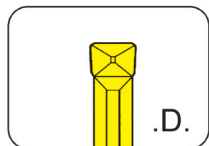

Page
U126

U

312

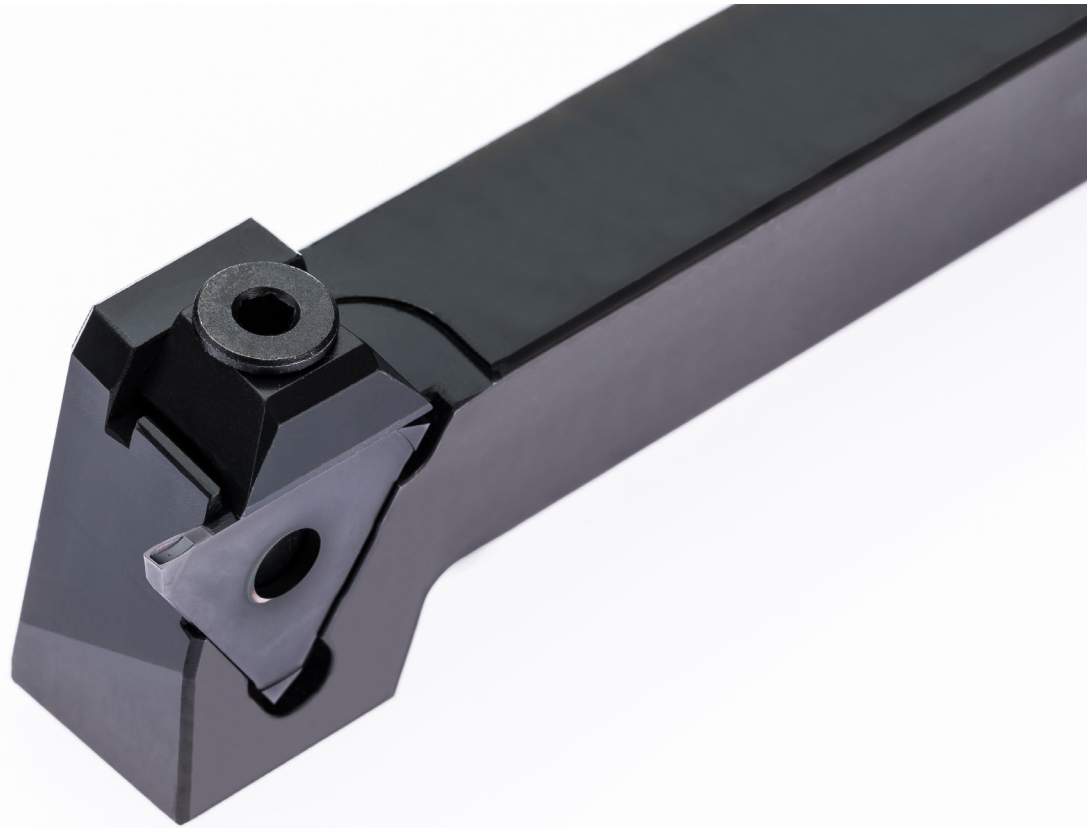

Toolholder with Inserts

Width of groove .020 - .118"

U

Toolholder

U360

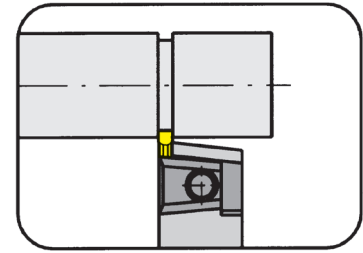

Depth of groove up to $.236''$
Clamping range $.020 - .114''$

for Indexable insert

Type 312
N312
S312
U312
US312

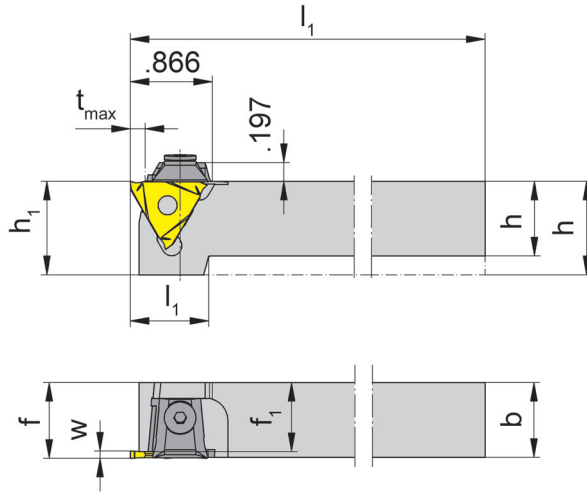

R = right hand version shown

L = left hand version

Part number	h	b	l_1	l_2	h_1	f_1	f	Size	Clamping range
R/LU360.0500.01	.500	.500	3.996	.945	.984	.441	f_1+w-a_1	01	.020 - .075
R/LU360.0625.01	.625	.625	5.118	.866	.984	.566	f_1+w-a_1	01	.020 - .075
R/LU360.0750.01	.750	.750	5.118	.827	.984	.691	f_1+w-a_1	01	.020 - .075
R/LU360.1000.01	1.000	1.000	6.004	-	1.000	.941	f_1+w-a_1	01	.020 - .075
R/LU360.1250.01	1.250	1.250	6.693	-	1.250	1.191	f_1+w-a_1	01	.020 - .075
R/LU360.0500.02	.500	.500	3.996	.945	.984	.402	f_1+w-a_1	02	.075 - .114
R/LU360.0625.02	.625	.625	5.118	.866	.984	.527	f_1+w-a_1	02	.075 - .114
R/LU360.0750.02	.750	.750	5.118	.827	.984	.652	f_1+w-a_1	02	.075 - .114
R/LU360.1000.02	1.000	1.000	6.004	-	1.000	.902	f_1+w-a_1	02	.075 - .114
R/LU360.1250.02	1.250	1.250	6.693	-	1.250	1.152	f_1+w-a_1	02	.075 - .114

State R or L version

w, a_1 see indexable inserts

Dimensions in inch

Further sizes upon request

t_{max} can be reached only with workpiece $\varnothing \leq 1.575''$

For torque specification of the screw, please see Technical Instructions.

Spare Parts

Toolholder	Allen wrench	Clamping element
R/LU360.0500/.0625...	SW3,0 DIN911	11.3
R/LU360...01/.02	SW3,0 DIN911	16.4

Toolholder

360

Depth of groove up to
Clamping range

6 mm
1.9 - 2.9 mm

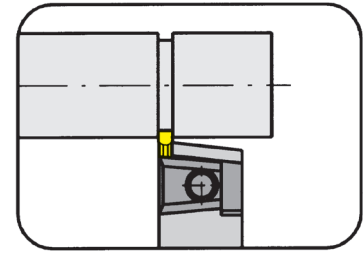

for Indexable insert

Type 312
N312
S312
U312
US312

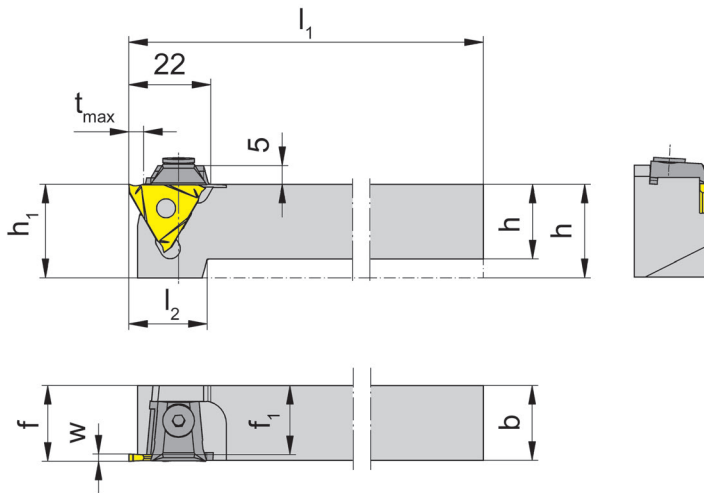

R = right hand version shown

L = left hand version

Part number	h	b	l ₁	l ₂	h ₁	f ₁	f	t _{max}	Size	Clamping range
R/L360.1212.02	12	12	100	24	25	9.5	f ₁ +w - a ₁	6	02	1.9 - 2.9
R/L360.1616.02	16	16	125	22	25	13.5	f ₁ +w - a ₁	6	02	1.9 - 2.9
R/L360.2020.02	20	20	125	21	25	17.5	f ₁ +w - a ₁	6	02	1.9 - 2.9
R/L360.2525.02	25	25	150	-	25	22.5	f ₁ +w - a ₁	6	02	1.9 - 2.9
R/L360.3232.02	32	32	170	-	32	29.5	f ₁ +w - a ₁	6	02	1.9 - 2.9

State R or L version

w, a₁ see indexable inserts

Dimensions in mm

Further sizes upon request

t_{max} can be reached only with workpiece Ø ≤ 40 mm

For torque specification of the screw, please see Technical Instructions.

Spare Parts

Toolholder	Allen wrench	Clamping element
R/L360.1...	SW3,0 DIN911	11.3
R/L360...	SW3,0 DIN911	16.4



Toolholder

368

Depth of groove up to
Width of groove

8 mm
0.5 - 1.5 mm

for machines TRAUB (TNL12/7)

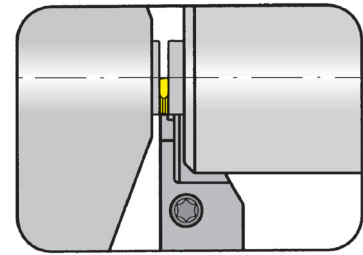

for Indexable insert

Type 312 w < 1.5 mm

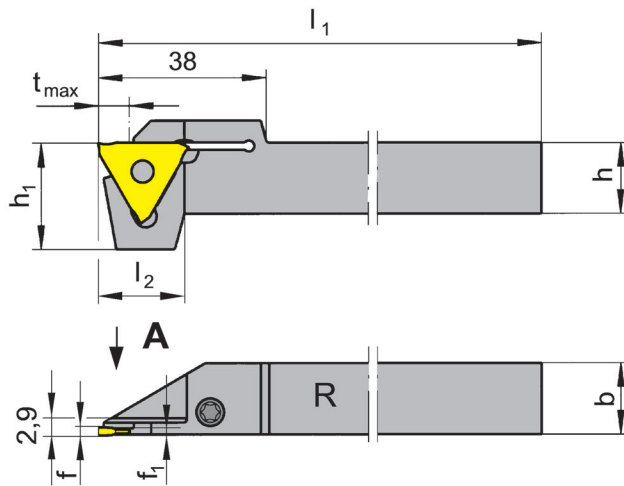

R = right hand version shown

L = left hand version

only for peripheral ground
profiled inserts

Part number	h	b	l ₁	l ₂	h ₁	f ₁	f	t _{max}
R/L368.1212.08	12	12	95	19.5	24	1.0	f ₁ +a ₁	8
R/L368.1616.08	16	16	95	19.5	24	1.0	f ₁ +a ₁	8
R/L368.1212.11	12	12	95	19.5	24	1.3	f ₁ +a ₁	8
R/L368.1616.11	16	16	95	19.5	24	1.3	f ₁ +a ₁	8

State R or L version

a1 see indexable inserts

Dimensions in mm

Toolholder R/L368...08 for indexable inserts:

R/L312.0805... / R/L312.0808... / R/L312.0510... R/L312.0512... / R/L312.1210.../ R/L312.0012...

Toolholder R/L368...11 for indexable inserts:

R/L312.0515... / R/L312.0015...V1

For torque specification of the screw, please see Technical Instructions.

Spare Parts

Toolholder	Clamping Screw	TORX PLUS® Wrench
R/L368...	4.15T15P	T15PQ

U116

Call Us Toll Free (888) 818-4676

Toolholder

368

reinforced version

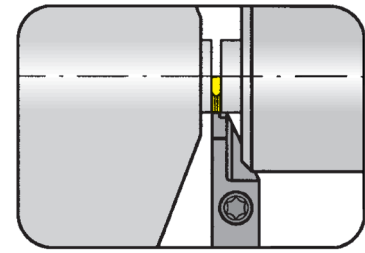

Depth of groove up to
Width of groove

8 mm
0.5 - 1.5 mm

for Indexable insert

Type 312 w < 1.5 mm

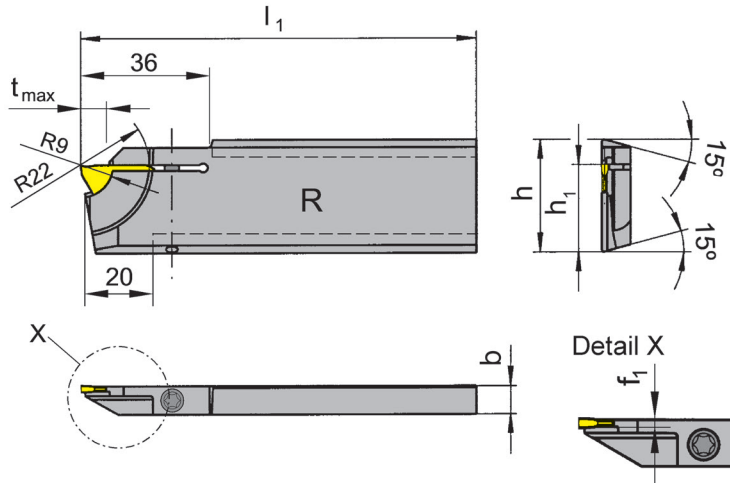

R = right hand version shown

L = left hand version

only for peripheral ground
profiled inserts

Part number	h	b	l ₁	h ₁	f ₁	t _{max}
R/L368.2608.08	26	8	110	21.4	1.0	8
R/L368.3208.08	32	8	110	24.8	1.0	8
R/L368.2608.11	26	8	110	21.4	1.3	8
R/L368.3208.11	32	8	110	24.8	1.3	8

State R or L version

Dimensions in mm

Toolholder R/L368...08 for indexable inserts:

R/L312.0805... / R/L312.0808... / R/L312.0510... R/L312.0512... / R/L312.1210... / R/L312.0012...

Toolholder R/L368...11 for indexable inserts:

R/L312.0515... / R/L312.0015...V1

For torque specification of the screw, please see Technical Instructions.

Spare Parts

Toolholder	Clamping Screw	TORX PLUS® Wrench
R/L368...	4.15T15P	T15PQ



Toolholder

368

reinforced version

Depth of groove up to
Width of groove

8 mm
1.1 - 2 mm

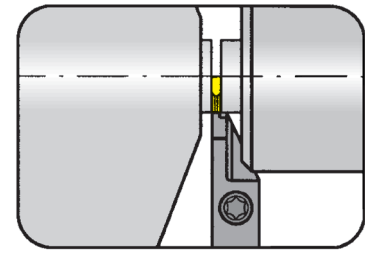

for Indexable insert

Type 312 w < 2.0 mm

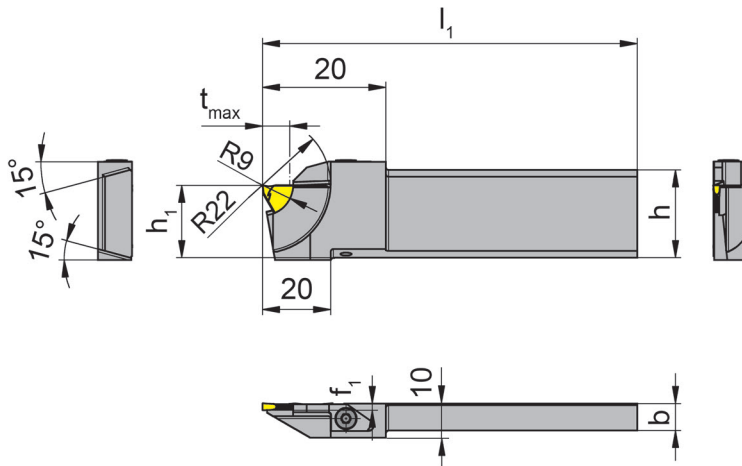

R = right hand version shown

L = left hand version

Part number	h	b	l ₁	h ₁	f ₁	t _{max}
R/L368.2608.10.01	26	8	110	21.2	1	8

State R or L version

Dimensions in mm

For torque specification of the screw, please see Technical Instructions.

Spare Parts

Toolholder	Clamping element	TORX PLUS® Wrench
R/L368.2608.10.01	010.0004.0536	T10PL

U118

Call Us Toll Free (888) 818-4676

Grooving (external)



Toolholder

391

Depth of groove up to 8 mm
Clamping range 0.5 - 1.9 mm

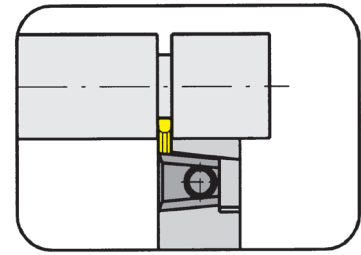

for Indexable insert

Type 312

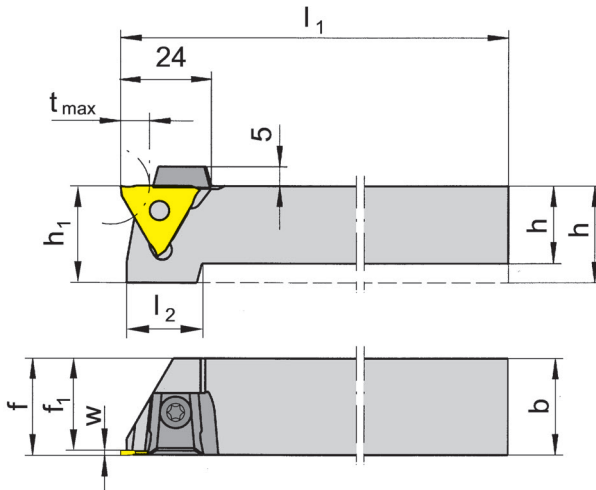

R = right hand version shown

L = left hand version

Part number	h	b	l ₁	l ₂	h ₁	f ₁	f	t _{max}	Size	Clamping range
R/L391.1212.01	12	12	100	21	21	10.5	f ₁ +w - a ₁	8	01	.5 - 1.9
R/L391.1616.01	16	16	125	21	21	14.5	f ₁ +w - a ₁	8	01	.5 - 1.9
R/L391.2020.01	20	20	125	21	21	18.5	f ₁ +w - a ₁	8	01	.5 - 1.9
R/L391.2525.01	25	25	150	-	25	23.8	f ₁ +w - a ₁	8	01	.5 - 1.9

State R or L version

w, a₁ see indexable inserts

Dimensions in mm

Further sizes upon request

t_{max} can be reached only with workpiece Ø ≤ 20 mm

For torque specification of the screw, please see Technical Instructions.

Spare Parts

Toolholder	Clamping element	TORX PLUS® Wrench	Allen wrench
R/L391.1212.01	12.3	T10PL	
R/L391.1616.01	14.4	T15PQ	
R/L391....	16.4		SW3,0 DIN911



Indexable insert

312

Depth of groove up to
Width of groove

.315"
.047 - .059"

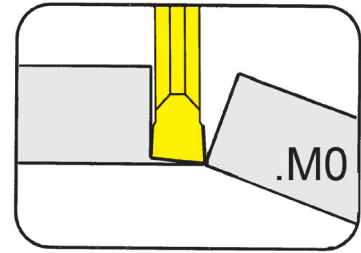

for Toolholder

Type 360
368
391

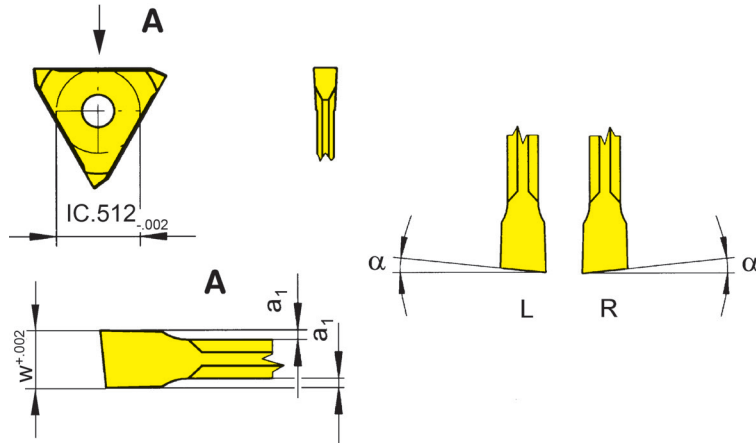

R = right hand version shown

L = left hand version

Part number	w	t _{max}	α	a ₁	Size	Carbide grades		
						K10	EG35	TF45
R/L312.0512.M0	.047	.315	5°	.008	01	x/Δ	▲/▲	▲/Δ
R/L312.0515.M0	.059	.315	5°	.008	01	▲/x	▲/▲	▲/Δ
						P	•	•
						M	○	•
						K	•	○
						N	•	-
						S	○	-
						H	-	-

▲ on stock Δ 4 weeks x upon request

- recommended
- alternative recommendation
- not suitable

- uncoated grades
- coated grades
- brazed/Cermet

Dimensions in inch

State R or L version

U

Indexable insert

312

Depth of groove up to
Width of groove

.315"
.047 - .079"

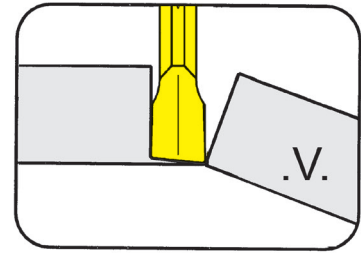

for Toolholder

Type 360
368
391

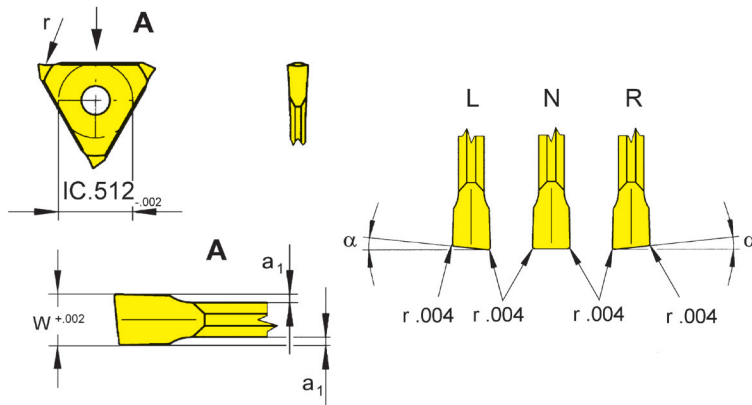

R = right hand version shown

L = left hand version

Part number	w	α	a ₁	Size	Carbide grades		
					EG35	TF45	TH35
312.0012.V1	.047	0°	.008	01	▲	▲	
R/L312.0512.V1	.047	5°	.008	01	▲/▲	▲/▲	
312.0015.V1	.059	0°	.008	01	▲	▲	
R/L312.0515.V1	.059	5°	.008	01	▲/▲	▲/▲	
R/L312.0520.V2	.079	5°	.008	01	▲/▲		▲/▲
					P	•	•
					M	•	•
					K	•	•
					N	-	•
					S	-	•
					H	-	-

▲ on stock Δ 4 weeks x upon request

● recommended
○ alternative recommendation
- not suitable

□ uncoated grades
■ coated grades
■ brazed/Cermet

Dimensions in inch

Carbide grades

State R or L version

Indexable insert R/L312...V2 for Toolholder R/L368.2608.10.01



Indexable insert

312

with round chip breaker

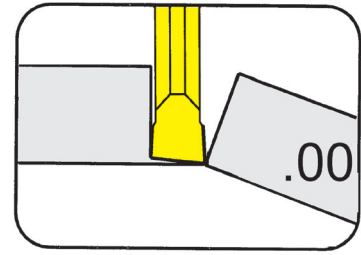

Depth of groove up to
Width of groove

.315"
.020 - .059"

for Toolholder

Type 360
368
391

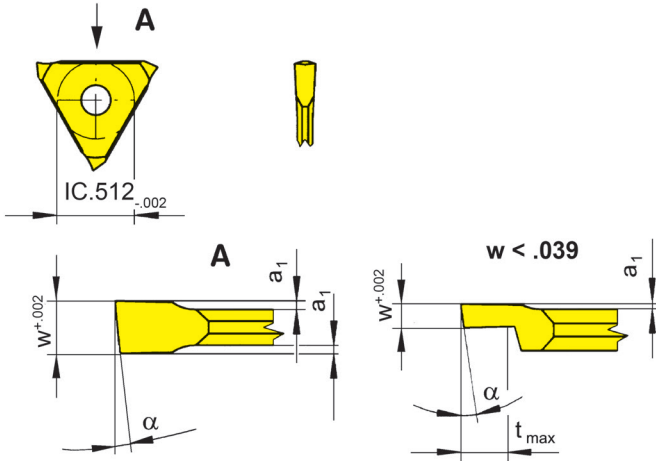

R = right hand version shown

L = left hand version

Part number	w	t _{max}	α	a ₁	Size	Carbide grades											
						K10	P20	EG35	EG55	TC92	TF45	TF46	T125	TN32	TN35	H20	
R/L312.0805.00	.020	.039	8°	.004	01			▲/▲			▲/▲						
R/L312.0808.00	.031	.059	8°	.004	01			▲/▲			▲/▲						
R/L312.0510.00	.039	.315	5°	.004	01			▲/▲			▲/▲						
R/L312.1210.00	.039	.315	12°	.004	01			▲/▲			▲/▲	x/x			▲/▲		
R/L312.0512.00	.047	.315	5°	.008	01			▲/▲			▲/▲						
R/L/312.0515.00	.059	.315	5°	.008	01	▲/x	▲/x	▲/▲	▲/x	x/x	▲/▲/▲	▲/x		▲/x			▲/x
▲ on stock Δ 4 weeks x upon request						P	•	•	•	•	•	•	•	•	•	•	•
● recommended						M	○	-	•	○	-	•	○	•	-	•	○
○ alternative recommendation						K	•	-	○	○	-	•	•	•	-	•	-
- not suitable						N	•	-	-	-	-	•	•	•	-	•	-
■ uncoated grades						S	○	-	-	-	-	○	•	•	-	•	-
■ coated grades						H	-	-	-	-	-	-	-	-	-	-	-
■ brazed/Cermet																	

Dimensions in inch

Carbide grades

State R or L version

U

Indexable insert

312

with round chip breaker

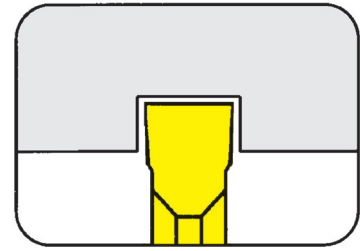

Depth of groove up to .197"
Width of groove .042 - .057"

for Toolholder

Type 360
391

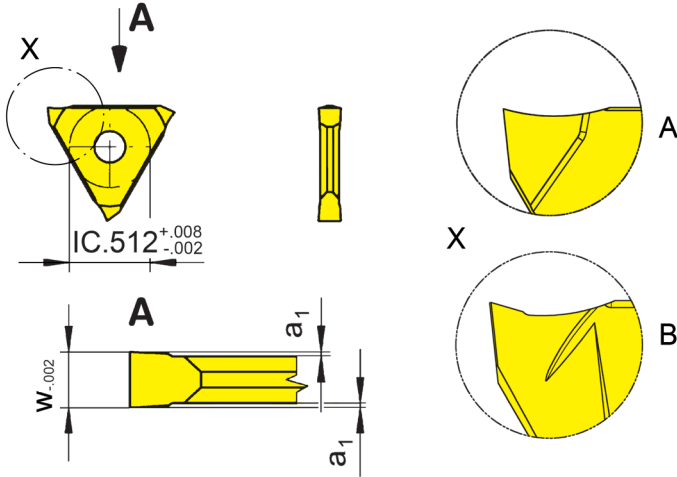

R = right hand version shown

L = left hand version

Part number	w	Nw	a ₁	Form	Size	K10	P20	EG35	EG55	TC92	TF45	TF46	TI25	TN32	TN35	H20	
312.0100.00	.042	.039	.004	A	01	▲	▲	■	▲	■	▲	▲	■	▲	▲	▲	x
312.0130.00	.057	.051	.008	A	01	▲	▲	■	▲	■	▲	▲	■	▲	▲	▲	■
▲ on stock Δ 4 weeks x upon request						P	●	●	●	●	●	●	●	●	●	●	●
● recommended						M	○	-	○	-	○	○	-	-	○	-	○
○ alternative recommendation						K	●	-	○	-	●	●	-	-	●	-	-
- not suitable						N	●	-	-	-	●	●	-	-	●	-	-
■ uncoated grades						S	○	-	-	-	○	○	-	-	○	-	-
■ coated grades						H	-	-	-	-	-	-	-	-	-	-	-
■ brazed/Cermet																	

Dimensions in inch

State R or L version

Carbide grades

External machining:

for Toolholder type 360 use right hand inserts in left hand toolholders and left hand inserts in right hand toolholders

Parting Off solid bars

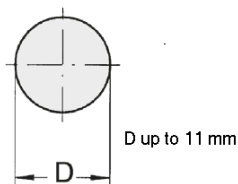

Parting Off tubes

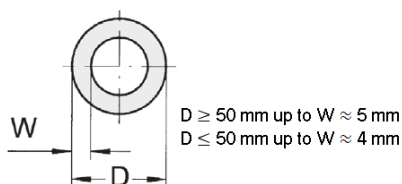

Indexable insert

312

with round chip breaker

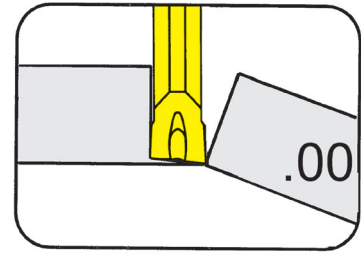

Depth of groove up to $.197''$
 Width of groove $.057 - .09''$

for Toolholder

Type 360
391

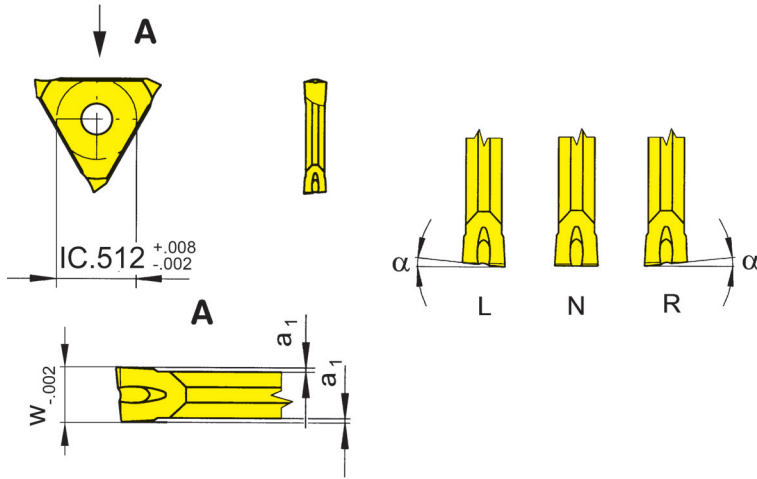

R = right hand version shown

L = left hand version

Part number	w	α	a ₁	Size	Carbide grades						
					MG12	P20	EG55	TC92	TF45	TN32	TN35
N312.0014.00	.057	0°	.008	02			▲	x	▲		
N312.0018.00	.078	0°	.008	02			▲	▲	▲	x	x
N312.0021.00	.090	0°	.008	02		x	▲	x			▲
R/L312.0514.00	.057	5°	.008	02		x/x	Δ/Δ		x/x		
R/L312.0518.00	.078	5°	.008	02		▲/▲	▲/▲	x/x		▲/▲	▲/▲
R/L312.0521.00	.090	5°	.008	02		x/x	▲/▲	x/x		▲/▲	▲/▲
					P	o	•	•	•	•	•
					M	-	-	o	-	•	•
					K	-	-	o	-	•	•
					N	-	-	-	-	•	•
					S	-	-	-	-	•	•
					H	-	-	-	-	-	-

▲ on stock Δ 4 weeks x upon request

• recommended

o alternative recommendation

- not suitable

uncoated grades

coated grades

brazed/Cermet

Dimensions in inch

State R or L version

External machining:

for Toolholder type 360 use right hand inserts in left hand toolholders and left hand inserts in right hand toolholders

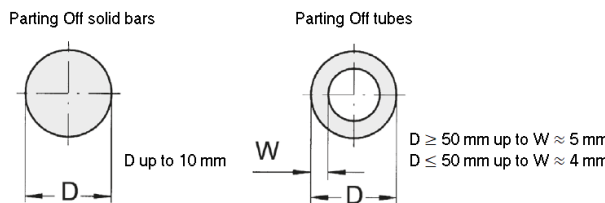

Indexable insert

S312

with sintered geometries

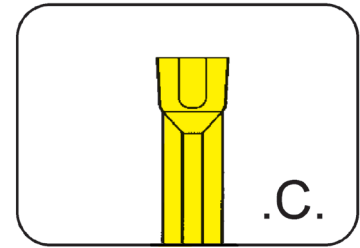

Depth of groove up to
Width of groove

.197"
.079 - .118"

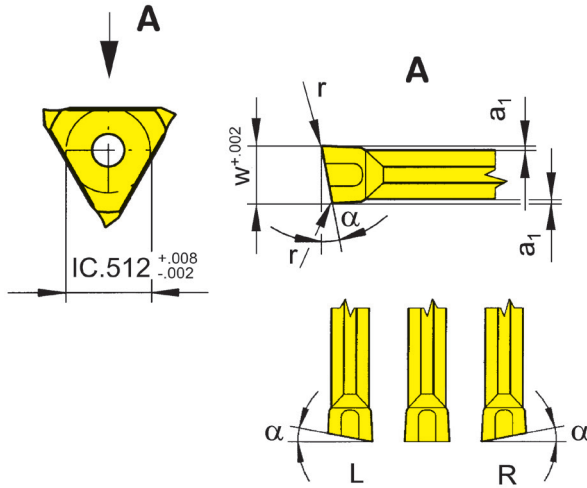

R = right hand version shown

L = left hand version

for Toolholder

Type 360
391

Geometry .C

Part number	w	r	α	a ₁	Size	EG55	TF46	T125
S312.0200.C2	.079	.008	0°	.01	02	▲	▲	▲
R/LS312.0520.C2	.079	.008	5°	.01	02	▲/▲	▲/▲	▲/▲
S312.0250.C2	.098	.008	0°	.01	02	▲	▲	▲
R/LS312.0525.C2	.098	.008	5°	.01	02	▲/▲	▲/▲	▲/▲
S312.0300.C2	.118	.008	0°	.01	03	▲	▲	▲
R/LS312.0530.C2	.118	.008	5°	.01	03	▲/▲	▲/x	▲/▲

State R or L version

Indexable inserts can be used in right and left hand toolholders.

▲ on stock Δ 4 weeks x upon request
● recommended
o alternative recommendation
- not suitable

uncoated grades
coated grades
brazed/Cermet

Dimensions in inch

P	●	●	●
M	o	o	●
K	o	●	●
N	-	●	●
S	-	o	●
H	-	-	-

Carbide grades



Indexable insert

S312

with sintered geometries

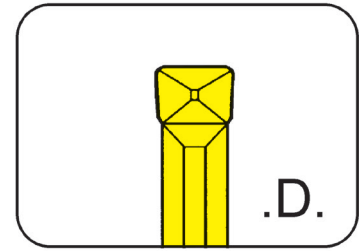

Depth of groove up to
Width of groove

.197"
.079 - .118"

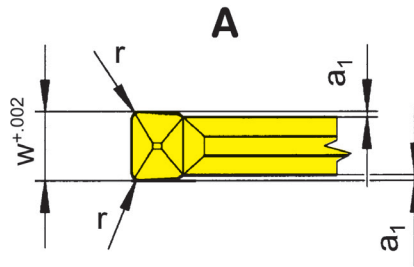
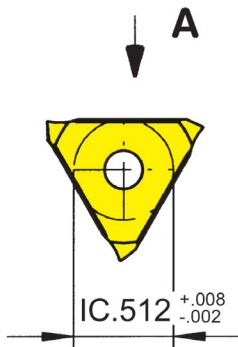

for Toolholder

Type 360
391

Geometry .D

Part number	w	r	a ₁	Size	AL96	AS62	AS66	EG56	TC92	TF45	TF46	TI25	TN32
S312.0200.D2	.079	.008	.01	02	x	▲	▲	▲	x	Δ	▲	▲	▲
S312.0200.D4	.079	.016	.01	02	x	▲	▲	▲	x	x	x	▲	▲
S312.0250.D2	.098	.008	.01	02	x	▲	▲	▲	▲	▲	▲	▲	▲
S312.0250.D4	.098	.016	.01	02	x	▲	▲	▲	▲	▲	▲	▲	▲
S312.0300.D2	.118	.008	.01	03	x	▲	▲	▲	x	▲	▲	▲	▲
S312.0300.D4	.118	.016	.01	03	x	▲	▲	▲	x	x	x	x	▲
					P	●	●	●	●	●	●	●	●
					M	-	-	o	o	-	●	o	●
					K	●	-	●	o	-	●	●	●
					N	●	-	●	-	-	●	●	-
					S	-	-	o	-	-	●	o	●
					H	-	-	-	-	-	-	-	-

▲ on stock Δ 4 weeks x upon request
 ● recommended
 o alternative recommendation
 - not suitable
 uncoated grades
 coated grades
 brazed/Cermet
 Dimensions in inch

Carbide grades

U

Indexable insert

S312

with sintered geometries

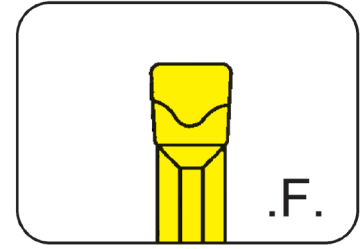

Depth of groove up to $.197''$
 Width of groove $.079 - .098''$

for Toolholder

Type 360
 391

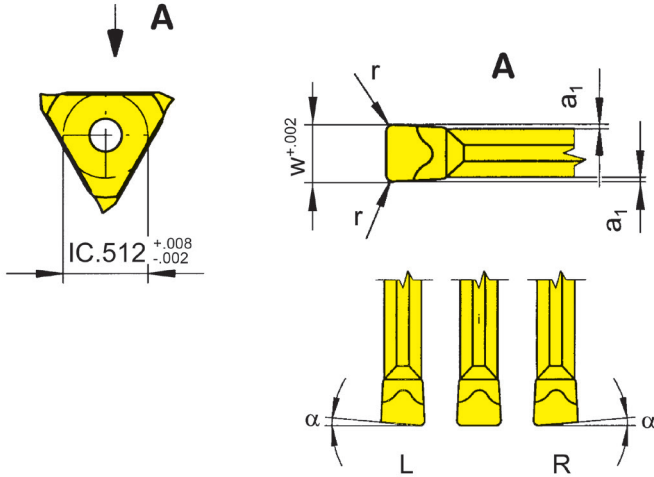

R = right hand version

L = left hand version

Geometry .F

Part number	w	r	α	a_1	Size	AL96	EG56	TC92	TF45	TF46	TI25
R/LS312.0520.F2	.079	.008	5°	.01	02		Δ/Δ			▲/▲	▲/▲
S312.0200.F2	.079	.008	0°	.01	02	x	▲	x	x	▲	▲
R/LS312.0525.F2	.098	.008	5°	.01	02		▲/Δ			▲/x	▲/▲
S312.0250.F2	.098	.008	0°	.01	02	x	Δ	x	x	▲	▲
						P	•	•	•	•	•
						M	-	o	-	•	o
						K	•	o	-	•	•
						N	•	-	-	•	•
						S	-	-	-	o	•
						H	-	-	-	-	-

▲ on stock Δ 4 weeks x upon request

• recommended
 o alternative recommendation
 - not suitable

□ uncoated grades
 ■ coated grades
 ■ brazed/Cermet

Dimensions in inch

State R or L version

Carbide grades



Toolholder

H316

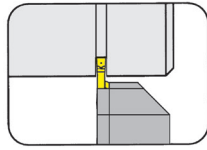

Page
U130

Indexable insert

S316

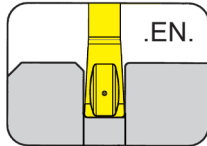

Page
U131

U

316

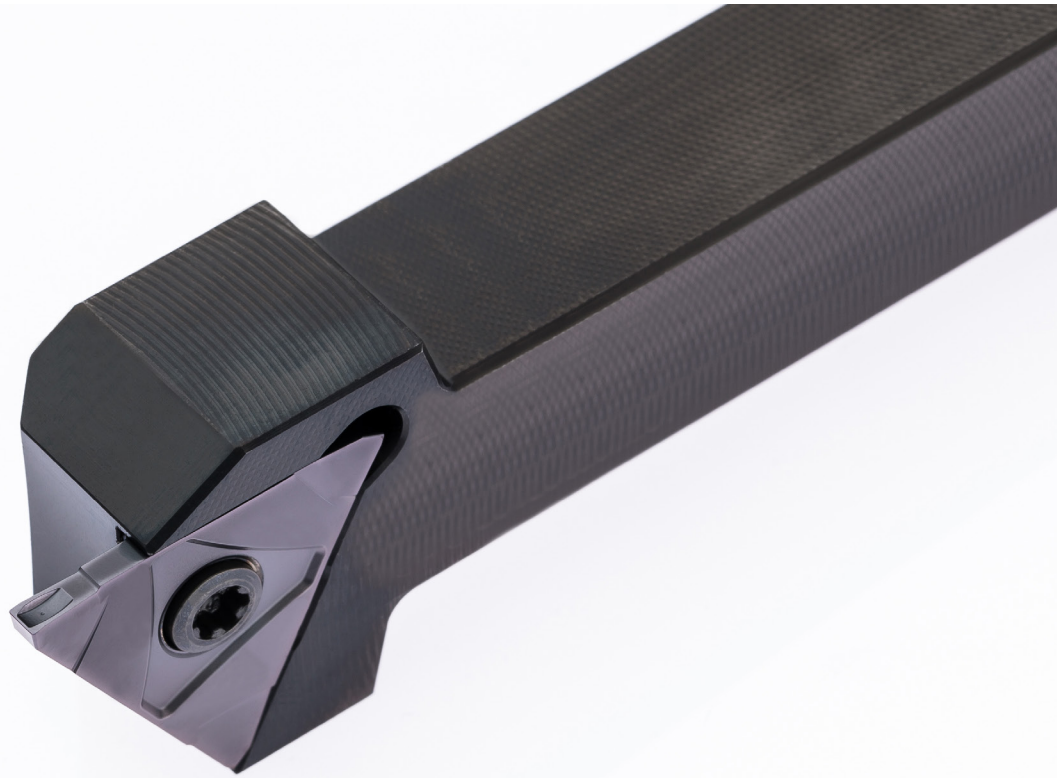

Toolholder with Inserts

Width of groove .079 - .118"

U

Grooving (external)



Toolholder

H316

Depth of groove up to
Clamping range

8 mm
1.5 - 3 mm

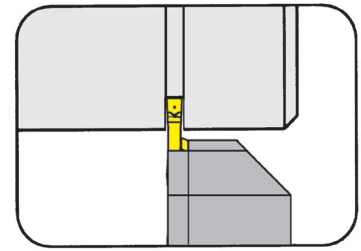

for Indexable insert

Type S316

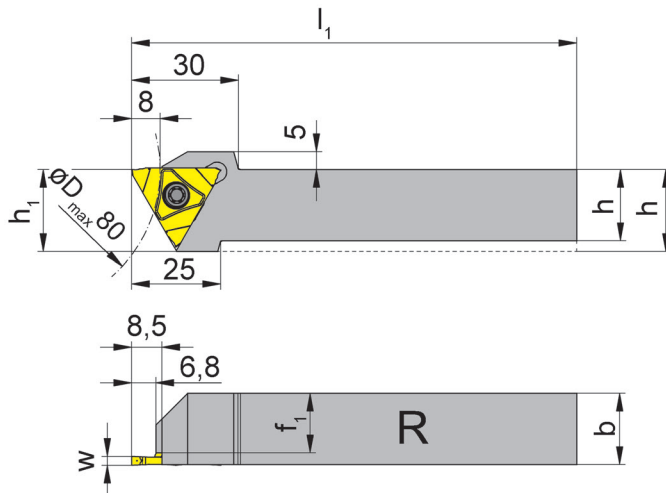

R = right hand version shown

L = left hand version

Part number	h	b	l ₁	h ₁	f ₁	Size
R/LH316.1616.S3.03	16	16	125	23	12.7	03
R/LH316.2020.S3.03	20	20	125	23	16.7	03
R/LH316.2525.S3.03	25	25	150	25	21.7	03
R/LH316.3225.S3.03	32	25	150	32	21.7	03

State R or L version

w see indexable inserts

Dimensions in mm

Further sizes upon request

For torque specification of the screw, please see Technical Instructions.

Spare Parts

Toolholder	Clamping Screw	TORX PLUS® Wrench
R/LH316...	5.12T20P	T20PQ

U130

Call Us Toll Free (888) 818-4676

Indexable insert

S316

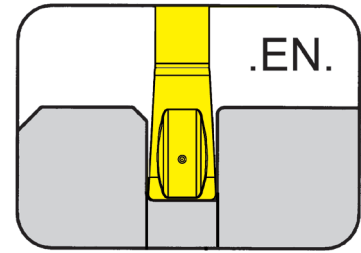

Depth of groove up to	.315"
Width of groove	.079 - .118"

precision sintered

for Toolholder

Type H316...S3.03

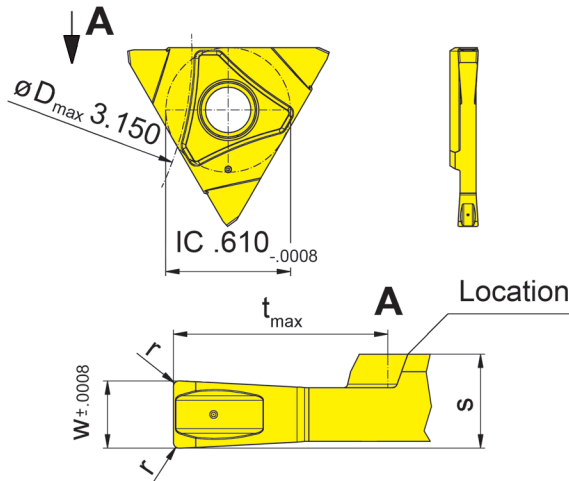

R = right hand version shown

L = left hand version

Indexability length $\pm .0008''$

Part number	w	r	t_{max}	s	Size	AS6G
R/LS316.0200.EN2	.079	.008	.315	.138	03	▲▲
R/LS316.0250.EN2	.098	.008	.315	.138	03	▲▲
R/LS316.0300.EN2	.118	.008	.315	.138	03	▲▲

▲	on stock	△	4 weeks	x	upon request
●	recommended	○	alternative recommendation	-	not suitable
□	uncoated grades	■	coated grades	■	brazed/Cermet

Dimensions in inch

State R or L version

Carbide grades

External machining:

Use right hand inserts in right hand toolholders and left hand inserts in left hand toolholders





U

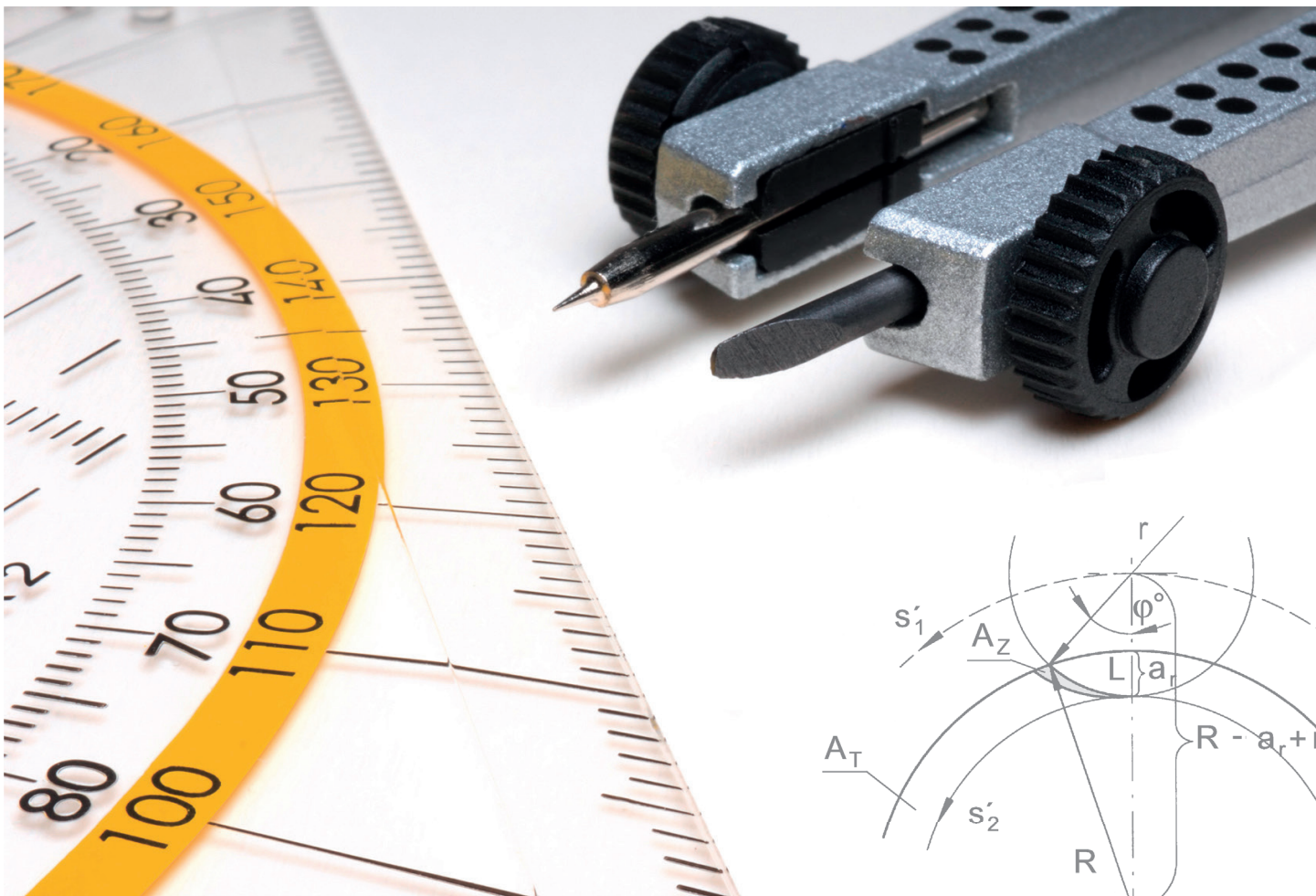

Summary

Page

Torque Specification

V2-V6

Technical Information

V7-V18

Geometries and Feed Rates

V19-V33

Cutting Data

V34-V37

Description of Carbide Grades

V38-V39

V

Torque of Screws



The values below are the recommended torque organized by holder type. We do not recommend additional MolyKote®, or copper paste on the insert screw

For torque screw drivers please see additional equipment.

Type	Screw	Torque M _q Nm	Clamping Wrench	Blade
050	030.0518.T20P	5.0	T20PQ	DT20PK
208	6.16	3.0	SW3DIN911	DSW30K
210	218.3	7.0	SW6DIN911	DSW60K
210...09/...K9	5.32T15P	5.0	T15PQ	DT15PK
211	6.19	3.0	SW3DIN911	DSW30K
213	218.3	7.0	SW6DIN911	DSW60K
213...09	5.32T15P	5.0	T15PQ	DT15PK
213...IK	DIN912-M6x14	6.0	SW5DIN911	DSW50K
214	218.3	7.0	SW6DIN911	DSW60K
214...09	5.32T15P	5.0	T15PQ	DT15PK
218	218.3	7.0	SW6DIN911	DSW60K
218...0.03.IK - 0.05.IK 218...2.03.IK - 2.05.IK	6.23.T25P	7.0	T25PQ	DT25PK
218...09/...K9	5.32T15P	5.0	T15PQ	DT15PK
219	218.3	7.0	SW6DIN911	DSW60K
219...09	5.32.3T15P	5.0	T15PQ	DT15PK
221	6.20.70P	5.0	T20PQ	DT20PK
225	218.3	7.0	SW6DIN911	DSW60K
226	218.3	7.0	SW6DIN911	DSW60K
226...09	5.32T15P	4.5	T15PQ	DT15PK
226...0.03.IK - 0.05.IK 226...2.03.IK - 2.05.IK	6.23.T25P	7.0	T25PQ	DT25PK
226.2608.../3208...	4.15T15P	5.0	T15PQ	DT15PQ
228	6.20.70P	5.0	T20PQ	DT20PK/DT20PQ
230	5.14	2.5	SW2,5DIN911	DSW25K
232	5.14	2.5	SW2,5DIN911	DSW25K
233	5.14	2.5	SW2,5DIN911	DSW25K
234	5.14	2.5	SW2,5DIN911	DSW25K
235	5.14	2.5	SW2,5DIN911	DSW25K
240	5.14	2.5	SW2,5DIN911	DSW25K
245	51.27.984P	4.0	T15PQ	DT15PK
248	5.14	2.5	SW2,5DIN911	DSW25K
250	5.14	2.5	SW2,5DIN911	DSW25K
253	5.14	2.5	SW2,5DIN911	DSW25K

V

Torque of Screws



Type	Screw	Torque M _q Nm	Clamping Wrench	Blade
254	5.14	2.5	SW2,5DIN911	DSW25K
255	5.14	2.5	SW2,5DIN911	DSW25K
257...05	218.3	6.5	SW6DIN911	DSW60K
257...07/...09	5.32.3T15P	5.0	T15PQ	DT15PK
309	6.25	4.5	SW3DIN911	DSW30K
330	5.12T20P	6.5	T20PQ	DT20PK/DT20PQ
333	5.12T20P	6.5	T20PQ	DT20PK/DT20PQ
340	6.25	4.5	SW3DIN911	DSW30K
356...3/...5	5.12T20P	6.5	T20PQ	DT20PK/DT20PQ
356...45.03	5F.08T20P	5.0	T20PQ	DT20PK/DT20PQ
356...6/...7/...10/...2.13 356...2.13.IK/...2.15.IK	5.15T20P	6.5	T20PQ	DT20PK/DT20PQ
357	5.12T20P	6.5	T20PQ	DT20PK/DT20PQ
360	6.25	4.5	SW3DIN911	DSW30K
361	030.0422.T10P	3.0	T10PL	DT10PK
368	4.15T15P	4.0	T15PQ	DT15PK
368...10.01	030.0422.T10	4.0	T10PL	DT10PK
369	6.25	4.5	SW3DIN911	DSW30K
390	6.25	4.5	SW3DIN911	DSW30K
391.1212...	030.0422.T10P	3.0	T10PL	DT10PK
391.1616...	5.32.3T15P	5.0	T15PQ	DT15PK
391.2...	6.25	4.5	SW3DIN911	DSW30K
974	030.3509.T15P	3.0	T15PQ	DT15PK
B105/BU105 B105KM BU105	6.075T15P	5.0	T15PQ	DT15PK
B105.A022...	030.0422.T10P	3.0	T10PL	DT10PK
B105MD	DIN913-M5x5	1.0	SW2,5DIN911	DSW25K
B108 B108KM	2.6.5T8EP	1.2	T8PL	DT8PK
B110	6.075T15P	5.0	T15PQ	DT15PK
B111	3.5.12T10EP	3.0	T10PL	DT10PK
B114	4.12T15EP	5.0	T15PQ	DT15PK
B119	5.11T15P	3.0	T15PL	DT15PK
B209	3.5.12T10EP	2.5	T10PL	DT10PK
B216.0020.1.2...IK	3.5.12T10EP	3.0	T10PL	DT10PK
B216...IK	5.13T20EP	6.0	T20PQ	DT20PK/DT20PQ
B223	5.11T15P	3.0	T15PL	DT15PK
B223...K2	4.09T15P	3.0	T15PL	DT15PK

V

Type	Screw	Torque M _d Nm	Clamping Wrench	Blade
B224.00...	5.13T20P	6.5	T20PQ	DT20PK/DT20PQ
B224.45... B224.60...	6.14T25P	7.0	T25PQ	DT25PK/DT25PQ
BK224	5.13T20EP	6.5	T20PQ	DT20PK/DT20PQ
BK229	5.13T20EP	6.0	T20PQ	DT20PK/DT20PQ
BKT	6.075T15P	5.5	T15PQ	DT15PK
E223	5.11T15P	3.0	T15PL	DT15PK
H32T...IK	030.2507.T7P	1.5	T7PL	DT7PK
H34T...10.IK	030.4093.T15P	3.0	T15PQ	DT15PK
H34T...20.IK	030.4010.T15P	5.0	T15PQ	DT15PK
H34T...30.IK	030.5012.T15P	6.0	T15PQ	DT15PK
H34T...40.IK	030.5012.T20P	6.0	T20PQ	DT20PK/DT20PQ
H64T...10.IK	030.4010.T15P	4.0	T15PQ	DT15PK
H64T...20.IK	030.4010.T15P	5.0	T15PQ	DT15PK
H105	6.075T15P	5.0	T15PQ	DT15PK
H100...01/...11/...21 + IK H100...02/...12/...22 + IK H100...71/...72 H100...71R/L/...72R/L	4.15T15P	5.0	T15PQ	DT15PK
H100...03/...13/...23 H100...04/...14/...24 H100...15 H100...1.23.IK	5.17T20P	6.5	T20PQ	DT20PK/DT20PQ
H100...04.IK H100...23.IK/...24.IK H100...73.IK/...74.IK	6.23T25P	7.0	T25PQ	DT25PK/DT25PQ
H100...73R/L/...74R/L	DIN912-M5x20	4.0	SW4DIN911	DSW40K
H100...83/...84	030.505P.0718	5.0	T15PQ	DT15PK
H100...83R/L/N/...84R/L/N	030.505P.0660	5.0	T15PQ	DT15PK
H100...93/...93R/L	030.0413.T15P	3.0	T15PQ	DT15PK
H100.2020.3.0.. H100.2525.3.0.. H100.3225.3.0./...38 H100.3225.4.0./...4.1.. H100...08/...10/...12	030.6075.T20P	5.0	T20PQ	DT20PK
H100.3232...	030.0625.T25P	7.0	T25PQ	DT25PK/DT25PQ
H100.52...	5.13T20P	5.0	T20PQ	DT20PK/DT20PQ
H117...10/...12 H117.1407.../...1439... H117.1441.../...1442...	4.09T15P	5.0	T15PQ	DT15PK
H117.1010.10	030.400P0227	5.0	T15PQ	DT15PK
H117...16/...32/...45 H117.1419.../...1440...	5.12T20P	6.0	T20PQ	DT20PK/DT20PQ

Torque of Screws



Type	Screw	Torque M _q Nm	Clamping Wrench	Blade
H117...20/...26	6.17T20P	7.0	T20PQ	DT20PK/DT20PQ
H117MD	030.400P.0227	5.0	T15PQ	DT15PK
H223	5.11T15P	3.0	T15PL	DT15PK
H223.2608.../.3208...	4.15T15P	5.0	T15PL	DT15PK
H224	6.23T25P	6.0	T25PQ	DT25PK/DT25PQ
H224.1212.81	6.17T25P	5.0	T25PQ	DT15PK
H224.1608.02/.23/.24 H224.2608.81/.82/.83	4.15T15P	5.0	T15PQ	DT15PK
H224.2608.01/.02 H224.3208.01/.02/.03	4.20T15P	4.3	T15PL	DT15PK
H224.2608.03	4.20T15P	4.3	T15PQ	DT15PK
H224.3208.93	030.0413T15P	3.0	T15PQ	DT15PK
H224...61/...62/...63/...64+IK	4.12.T15EP	5.0	T15PL	DT15PK
H224.1212.20...	4.12.T15EP	5.0	T15PQ	DT15PK
H224...65/...66/...83R	5.13.T20EP	6.5	T20PQ	DT20PK/DT20PQ
H262	030.2557.T8P	1.0	T8PL	DT8PK
H264 H264KM	3.5.12T10EP	3.0	T10PL	DT10PK
H274...04/...04.E	030.3509.T15P	3.0	T15PQ	DT15PK
H274...07	030.3513.T15P	3.0	T15PQ	DT15PK
H274KM	030.3509.T15P	3.0	T15PQ	DT15PK
H316	5.12T20P	6.5	T20PQ	DT20PK/DT20PQ
HC105	6.075T15P	5.5	T15PQ	DT15PK
HC105MD	DIN911-M4x5	1.0	SW2,0DIN911	SW20K
HC114	4.12T15EP	5.0	T15PQ	DT15PK
HC274KM	030.3509.T15P	3.0	T15PQ	DT15PK
HC316	5.12T20P	6.5	T20PQ	DT20PK/DT20PQ
KT274 KTC274	030.3509.T15P	3.0	T15PQ	DT15PK
L368	4.18T15EP	4.0	T15PQ	DT15PK
L849.0226.L...	6.23T25P	7.0	T25PQ	DT25PK/DT25PQ
LA210	218.3	7.0	SW6.911	DSW60K
LA226	218.3	7.0	SW6.911	DSW60K
LAK220	6.23T25P	7.0	T25PQ	DT25PK/DT25PQ
LAK224	5.13T20P	6.0	T20PQ	DT20PK/DT20PQ
LIK220	6.23T25P	7.0	T25PQ	DT25PK/DT25PQ
LIK224	5.13T20P	6.0	T20PQ	DT20PK/DT20PQ
LNK368	5.10T20P	6.0	T20PQ	DT20PK/DT20PQ
LNK760	5.13T20EP	6.0	T20PQ	DT20PK/DT20PQ

V

Type	Screw	Torque M _d Nm	Clamping Wrench	Blade
N849...10.00/...12.00	4.09T15P	5.0	T15PQ	DT15PK
N849...16.00/...32.00	5.12T20P	6.5	T20PQ	DT20PK/DT20PQ
N849...20.00/...26.00	6.17T20P	7.0	T20PQ	DT20PK/DT20PQ
N849...K1	DIN1835-B M10x12	6.0	SW5,0DIN911	DSW50K
NH105MD	DIN911-M4x5	1.0	SW2,0DIN911	SW20K
NK100	5.13T20P	6.5	T20PQ	DT20PK/DT20PQ
NK100.0840...	4.20T15P	4.3	T15PL	DT15PK
NK100.3215...	6.23T25P	7.0	T25PQ	DT25PK/DT25PQ
NK220	6.23T25P	7.0	T25PQ	DT25PK/DT25PQ
NK224.3215...	5.13T20P	6.0	T20PQ	DT20PK/DT20PQ
NK224.0840...	5.12T20P	6.5	T20PQ	DT20PK/DT20PQ
NK264	4.20T15P	4.3	T15PL	DT15PK
NK274	030.3509.T15P	3.0	T15PQ	DT15PK
NK356	5.12T20P	6.0	T20PQ	DT20PK/DT20PQ
NK360	5.12T20P	6.0	T20PQ	DT20PK/DT20PQ
NK360.0220...	5.32.3T15P	5.0	T15PQ	DT15PK
NK360.0840.1.01/02/03	030.0422.T10P	3.0	T10PL	DT10PK
NK360.0840.1.04	5.32.3T15P	5.0	T15PQ	DT15PK
NK368	030.400P.0602	4.0	T10PL	DT10PK
R76	030.3509.T15P	5.0	T15PQ	DT15PK
R849.0226.R...	6.23T25P	7.0	T25PQ	DT25PK/DT25PQ
R849...K2	DIN913-M8x12	7.0	SW5DIN911	DSW50K
RA210	218.3	7.0	SW6.911	DSW60K
RA226	218.3	7.0	SW6.911	DSW60K
RAK220	6.23T25P	7.0	T25PQ	DT25PK/DT25PQ
RAK224	5.13T20P	6.0	T20PQ	DT20PK/DT20PQ
RBA114	4.12.T15EP	5.0	T15PQ	DT15PK/DT15PQ
RIK220	6.23T25P	7.0	T25PQ	DT25PK/DT25PQ
RHC274	030.3509.T15P	5.0	T15PQ	DT15PK
RIK224	5.13T20P	6.0	T20PQ	DT20PK/DT20PQ
SB105	6.075T15P	5.0	T15PQ	DT15PQ
SB110	6.075T15P	5.0	T15PQ	DT15PQ
SH117...08	030.3509.T15P	3.5	T15PQ	DT15PK
SH117...10/...12	4.09T15P	5.0	T15PQ	DT15PK
SH117...16	5.12T20P	6.5	T20PQ	DT20PK/DT20PQ
SHM117...08	030.3509.T15P	3.5	T15PQ	DT15PK
VDI	6.075T15P	5.0	T15PQ	DT15PK

V

Side Turning

HORN-Grooving Tools will give you absolute accuracy of profile and angles, even when profiling with one-sided cutting forces.

A flexible cutting edge would be desirable for turning, but not useful for precision grooving.

Please note when setting tool:

Always ensure that the tool is perpendicular to the axis of the workpiece.

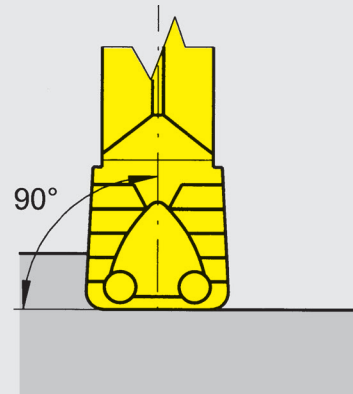

Improper setting:

Feed direction **1** will create vibrations. The tendency to vibrate will increase on rigid workpieces.

Feed direction **2** is suitable for turning and will have no negative effects to the operation.

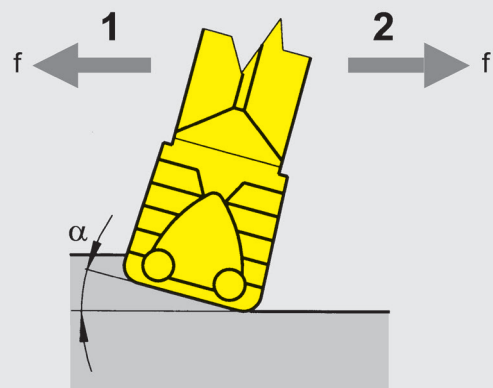

Side Turning

The grooving tool should not be seen as a replacement for a turning tool with ISO-inserts. On certain operations, for instance grooving and turning can reduce the number of tool changes and offer reduced cycle time.

Width of insert:

The width 4, 5 and 6 mm are recommended for side turning. The profile and rigidity of the workpiece determines the width of insert. Always choose the largest possible edge radius.

Width	4 mm	5 mm	6 mm	
$a_{p \max}$	2.8	3.5	4.0	.3.
f	0.15 - 0.30	0.15 - 0.40	0.15 - 0.40	
$a_{p \max}$	2.8	3.5	4.0	
f	0.15 - 0.30	0.15 - 0.50	0.15 - 0.60	
$a_{p \max}$	2.8	3.5	4.0	.A.
f	0.10 - 0.25	0.10 - 0.30	0.10 - 0.30	

Cutting depth a_p :

When side turning the cutting depth is dependent upon the width of insert as well as on the material and the rigidity of the workpiece. The max. depth would be limited by the length of the cutting edge.

Rule of thumb for calculation:

$$a_{p \max} = w \times 0.7 \text{ or max } 3.0 \text{ mm}$$

$$a_{p \min} = \text{corner radius } (r)$$

The smallest cutting depth $a_{p \min}$ is governed by the edge radius of the insert. Cutting depth below the corner radius will create poor cutting conditions.

Maximum feed rate f_{\max} :

Rule of thumb for calculation:

$$f_{\max} = w \times 0.1$$

Side Turning

Side turning between shoulders

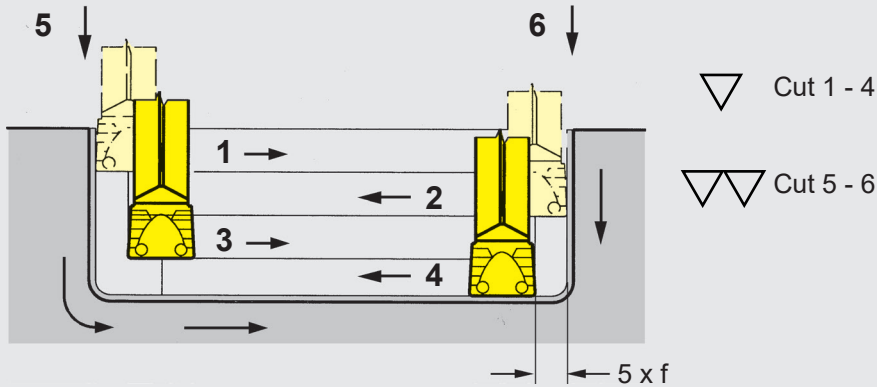

Always start at the shoulder when side turning, towards shoulder. An operation towards the shoulder will influence the run off the chip and creates the risk of insert breaking. Grooving and turning is recommended as shown.

Cut 2 and subsequent cuts leave a distance of $5 \times f$ to the shoulder. This cut width will help to prevent swarf being trapped under the advancing cutting edge.

Chamfering with standard inserts

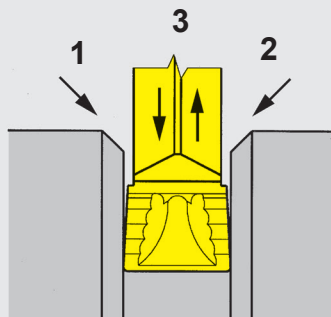

Width of groove and insert are equal

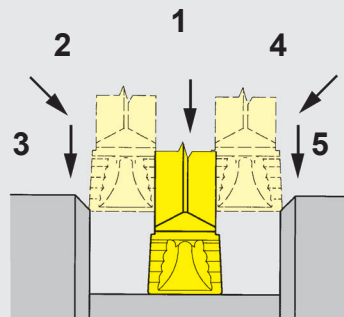

Groove wider than insert

Finishing of Grooves

(Sealing Grooves)

This process requires both turning and grooving where very high quality surface finishes are required.

Diagram 2 shows the modified insert type S224...NC...D2.

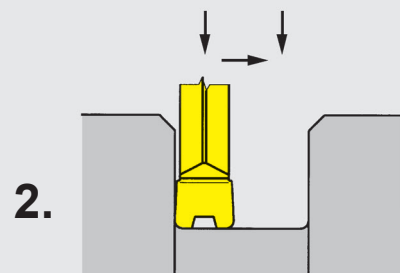
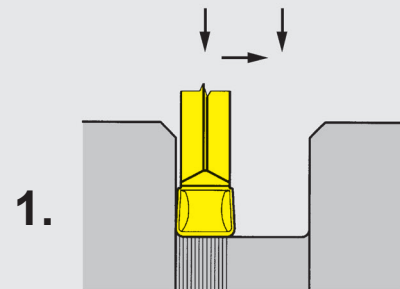

Swarf Ring Creation

Swarf ring creation can be avoided by turning across the smaller diameter in one continuous pass.

Well defined cutting edges and small corner radii will reduce the tendency to create rings.

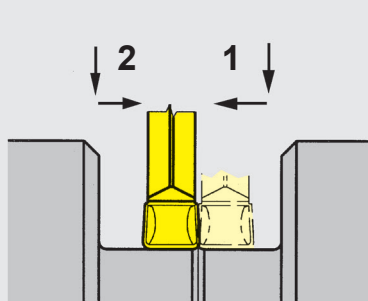

Ring Creation

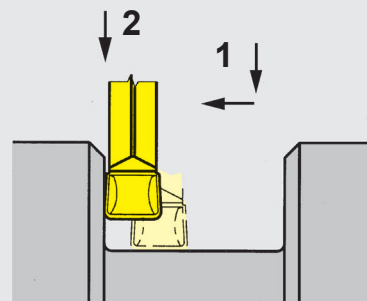

No Ring Creation

Face Grooving

Cassette Selection

Select the cassette to suit the major diameter of the face groove to be cut.

Stable Setup

The tool should be set to give the minimum overhang to achieve maximum stability.

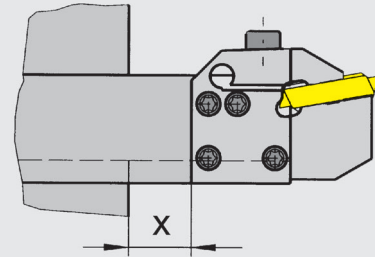

Working Practice

When turning to open up the face groove the cut should be taken from the major \varnothing towards the minor \varnothing .

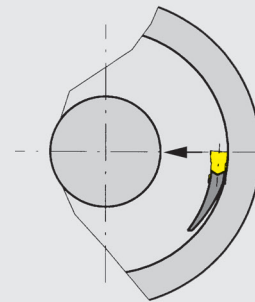

Tool Setup

The tool should be set to center height to ensure correct cutting and support clearance.

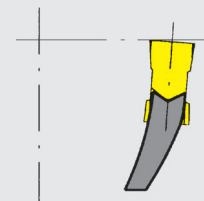

The tool must be set parallel to the rotation axis of the workpiece.

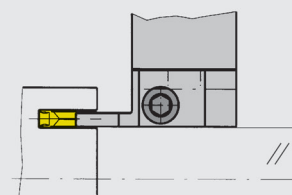

V

Profile Inserts

Examples of Profiles

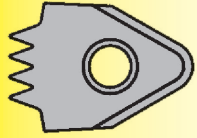

Profile inserts are manufactured according to customer specific requirements.

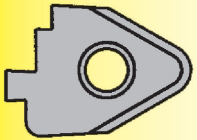
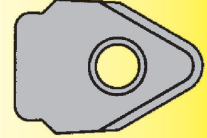

It is also possible to supply inserts with different relief angles. If the customer wants to regrind or resharpen the insert, we recommend to use small relief angles around the cutting edge profile.

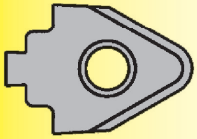
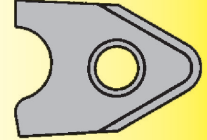

The number of regrinds depends on the condition of each individual insert.

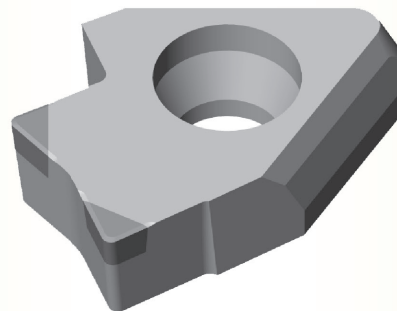
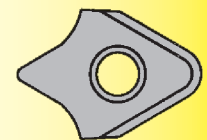
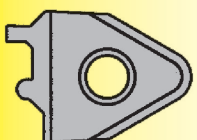
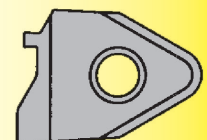
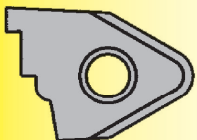
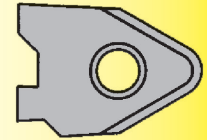
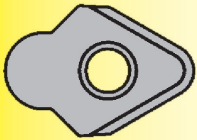
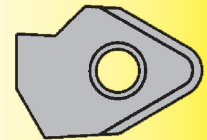
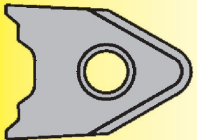
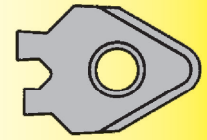
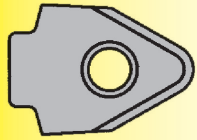
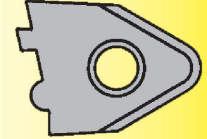

PCD- or PCBN-tipped inserts upon request.

V

Metric ISO Standard Thread (External)

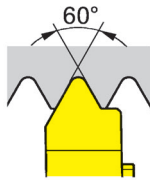

Thread	Partial Profile	Full Profile
M6 (M7)	R/L315.0610.01	R/L315.0610.02
M8 (M9)	R/L315.0712.01	R/L315.0712.02
M10 (M11)	R/L315.0915.01	R/L315.0915.02
M12	R/L315.1017.01	R/L315.1017.02
M14; M16	R/L315.1220.01	R/L315.1220.02
M18; M20; M22	R/L315.1525.01	R/L315.1525.02
M24; M27	R/L315.1830.01	R/L315.1525.02
M30; M33	R/L315.2135.01	R/L315.2135.02
M36	-	R/L315.2440.02
M24 - M68	R/L315.3060.01	-
M48; M52	-	R/L315.3050.02
M64; M68	-	R/L315.3660.02

Metric ISO Fine Thread (External)

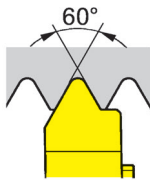

Thread	Partial Profile	Full Profile
M7,5x1	R/L315.0610.01	R/L315.0610.02
M10x1,25	R/L315.0712.01	R/L315.0712.02
M12x1,5	R/L315.0915.01	R/L315.0915.02
M17x2	R/L315.1220.01	R/L315.1220.02
M24x2,5	R/L315.1525.01	R/L315.1525.02
M30x3	R/L315.1830.01	R/L315.1525.02

Metric ISO Fine Thread (Internal)

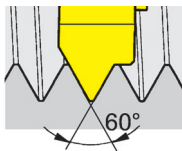

Thread	Partial Profile	Full Profile
M45x1	R/L315.0510.01	R/L315.0510.02
M45x1,5	R/L315.0815.01	R/L315.0815.02
M48x2	R/L315.1020.01	R/L315.1020.02
M48x2,5	R/L315.1325.01	R/L315.1325.02
M48x3	R/L315.1630.01	R/L315.1630.02
M48x3,5	R/L315.1835.01	R/L315.1835.02

Full Profile, Whitworth (External)



Thread	Full Profile
G ^{1/16} / G ^{1/8}	R/L315.5528.02
G ^{1/4} / G ^{3/8}	R/L315.5519.02
G ^{1/2} / G ^{3/4}	R/L315.5514.02
G1 - G6	R/L315.5511.02

Metric ISO Trapezoidal Thread DIN103 (External)

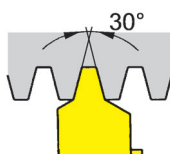

Thread	Full Profile
Tr8x1,5	R/L315.1015.02
Tr9-10x2	R/L315.1320.02
Tr12-14x3	R/L315.1730.02
Tr16-20x4	R/L315.2240.02
Tr22-28x5	R/L315.2750.02
Tr30-36x6	R/L315.3560.02

Recommended Number of Passes

Carbide grade TN35	Steel					Stainless Steel	Grey Cast Iron	Aluminium	
	Tensile Strength N/mm ²	400-500	500-700	700-850	850-1150				> 1150
	Tensile Strength KSI	58 - 73	73 - 102	102 - 123	123 - 168				> 168
V_{max} m/min	160	140	120	90	70	90	100	300	
V_{max} SFM	525	459	394	295	230	295	328	984	
Pitch		Number of Passes							
mm	TPI								
0.8	32	8	8	9	9	10	10	9	8
1.0	24	10	10	12	12	12	12	12	10
1.25	20-19	12	12	14	14	15	15	14	12
1.5	16	15	15	17	17	18	18	17	15
1.75	14	17	17	19	19	21	21	18	17
2.0	12-11	19	20	22	22	25	25	20	18
2.5	10	22	24	26	26	31	31	22	20
3.0-3.5	8	28	30	32	32	38	38	24	22

Feed Direction Internal Threading

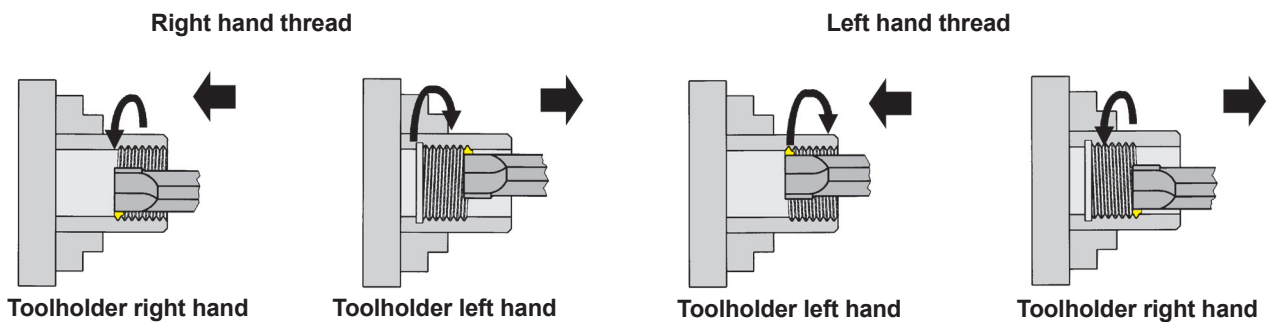

In-Feed Methods

Radial In-Feed

Metal removed on both sides of the insert simultaneously. The most commonly used method for thread production.



Modified Flank In-Feed

Less wear of the trailing edge and better surface finish on corresponding flank.



Alternating Flank In-Feed

Both edges are being fully utilised which means longer insert life.



Flank in-Feed

More easily formed chip and better heat dissipation.



Parting Off

Grooving Inserts with 0° Lead angle

For parting off, use inserts with 0° lead angle whenever possible.

Advantages:

- increased tool life
- better swarf control and a high surface quality will be obtained
- possibility to choose the maximum cutting data

Feed Rates

The feed rate when cutting with front cutting angle will need to be reduced up to 40%. This may also be influenced by the tensile strength of the material to be cut.

Swarf Control

Best swarf control and highest surface finish will be obtained by choosing the right speed and feed rate.

Avoiding Pips

To avoid pips, use right or left handed inserts with the appropriate lead angle.

Parting Off with a Sub Spindle or Part Catcher

Use the subspindle or part catcher to support the workpiece during partoff. This will minimize damage to the cutting edge and improve tool life. If a subspindle is not available, reduce feed as tool approaches center.

Convex or Concave Surfaces

When using handed inserts with lead angles, convex or concave surfaces can be avoided by reducing the feed rate.

Coolant

A copious well aimed coolant supply will give longer tool life.

Internal Coolant Supply Options

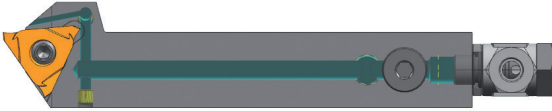

External connection e.g. through high pressure pump to the toolholder.

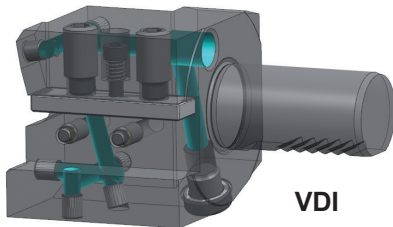

VDI

Internal connection through turret to the toolholder.

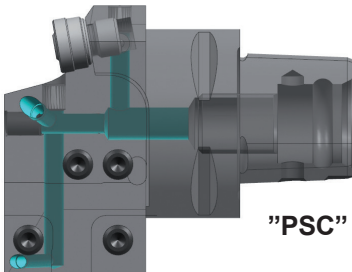

"PSC"

Internal connection through toolholder back-end to the cassette.

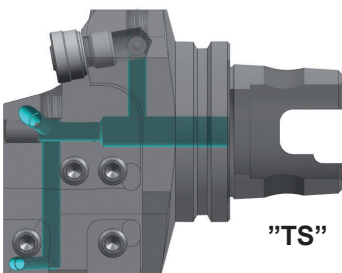

"TS"

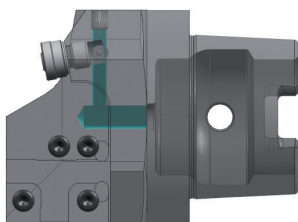

HSK

V

Coolant Output Options

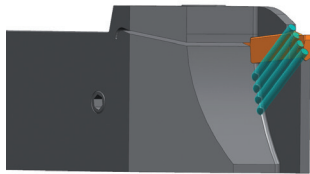

Coolant outlet through spray nozzle at the side of the insert.

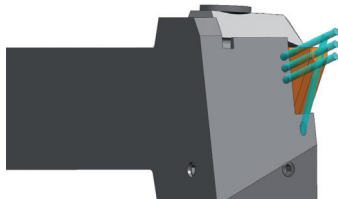

Coolant outlet through spray nozzle at the side of the insert.

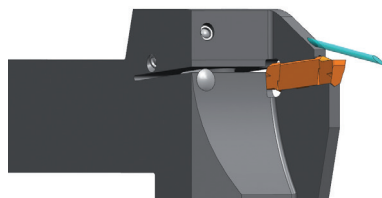

S100
S224
S229

Coolant outlet through clamping finger.

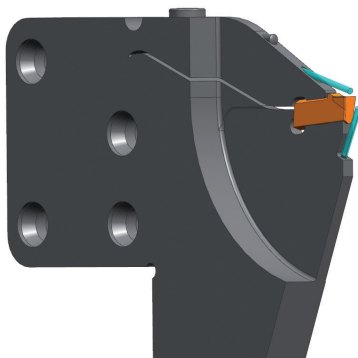

S100
S224
S229

Coolant outlet through clamping finger and insert support.

V

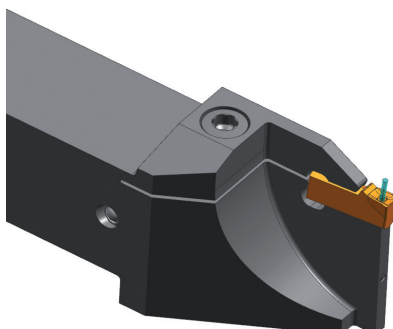

S100
S224

Coolant outlet through insert.

Reinforced Blades - Positioning

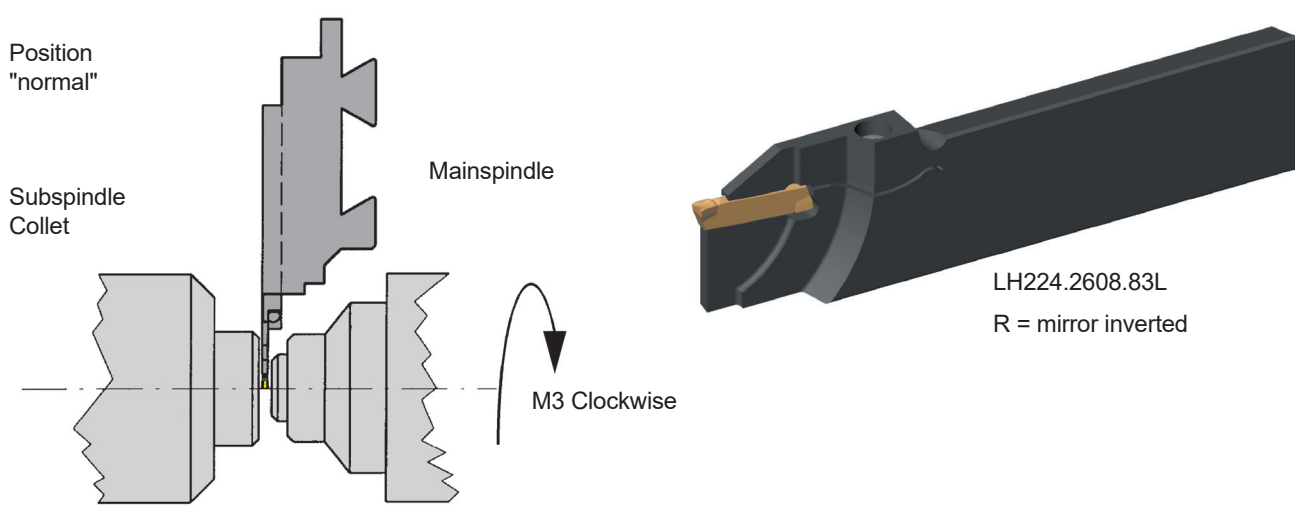
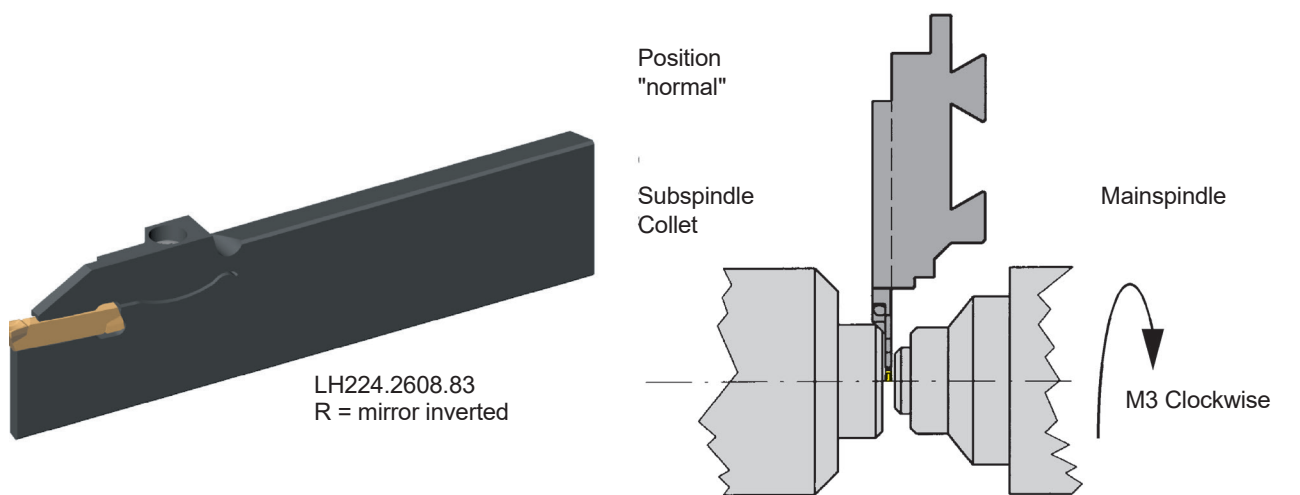
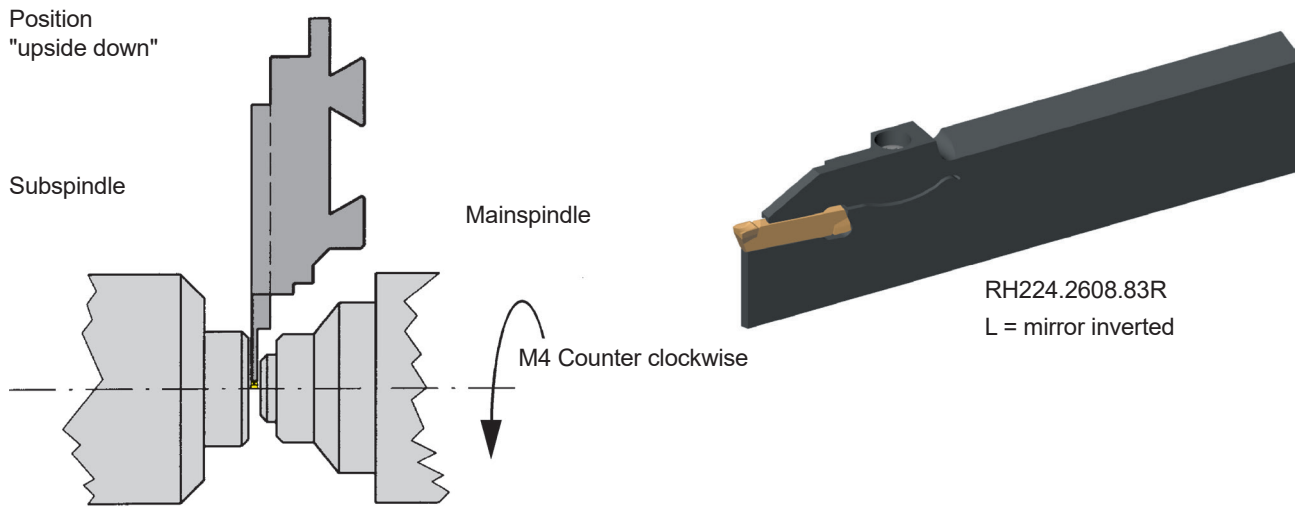

These special reinforced forms can be produced on all blades.

Geometry	Applications	Feed Rate	
		f (mm/rev)	f (ipr)
.3. 	Grooving, finishing of grooves, geometry for inserts with profile, for short chipping materials and high tensile strength	↓ 0.03 - 0.15	.0012 - .0059
		↔ 0.05 - 0.20	.0020 - .0079
		$a_{p\ max} = 1.5 \times w$	
.C. 	Parting off, for long chipping materials	↓ 0.02 - 0.12	.0008 - .0047
		$a_{p\ max} = 1.5 \times w$	
.5. 	Grooving, side turning, profiling of grooves, excellent reduction of chip width in materials with medium tensile strength	↓ 0.08 - 0.20	.0031 - .0079
		↔ 0.15 - 0.20	.0059 - .0079
		$a_{p\ max} = 1.5 \times w$	
		↓ Grooving	↔ Turning



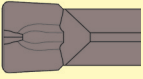
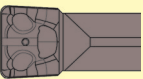
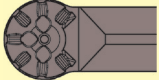



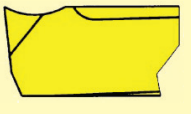
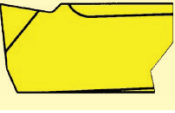

Geometry	Applications	Feed Rate	
		f (mm/rev)	f (ipr)
.1A. 	Grooving, finishing of grooves, for long chipping materials, low feed rates	↓ 0.03 - 0.12	.0012 - .0047
.5. 	Grooving, side turning, profiling of grooves, excellent reduction of chip width in materials with medium tensile strength	↓ 0.06 - 0.20	.0024 - .0079
		↔ 0.05 - 0.20	.0020 - .0079
.KF 	Grooving, side turning, profiling of grooves, excellent reduction of chip width in materials with medium tensile strength	↓ 0.03 - 0.15	.0012 - .0059
		↔ 0.05 - 0.15	.0020 - .0059

↓ Grooving ↔ Turning

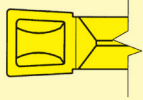
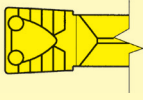
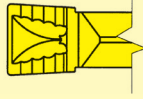
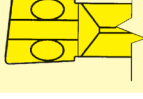
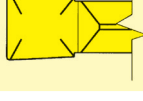
Geometry	Applications	Feed Rate	
		f (mm/rev)	f (ipr)
.00 	Grooving, finishing of grooves, for long chipping materials, low feed rates	↓ 0.02 - 0.12	.0008 - .0047
Chipbreaker for special inserts 	Grooving, finishing of grooves, geometry for inserts with profile, for short chipping materials and high tensile strength	↓ 0.02 - 0.12	.0008 - .0047

↓ Grooving ↔ Turning



Geometry	Applications	Feed Rate	
		f (mm/rev)	f (ipr)
.3. 	Grooving, side turning, profiling of grooves, suitable for materials with high tensile strength	↓ 0.15 - 0.20	.0059 - .0079
		↔ 0.15 - 0.40*	.0059 - .0157
.5. 	Grooving, side turning, profiling of grooves, excellent reduction of chip width in materials with medium tensile strength	↓ 0.10 - 0.45	.0039 - .0177
		↔ 0.15 - 0.60*	.0059 - .0236
.A. 	Grooving, side turning, finishing or profiling of grooves, excellent chip breaking in materials with medium tensile strength	↓ 0.05 - 0.30	.0020 - .0118
		↔ 0.10 - 0.30*	.0039 - .0118
.C. 	Parting off, for long chipping materials	↓ 0.02 - 0.10	.0008 - .0039
.D. 	Grooving, finishing of grooves, for long chipping materials, low feed rates	↓ 0.03 - 0.15	.0012 - .0059
		↔ 0.05 - 0.20	.0020 - .0079
.E./EN. 	Grooving, side turning, profiling of grooves, suitable for materials with high tensile strength	↓ 0.08 - 0.30	.0031 - .0118
.F./FY 	Grooving, finishing of grooves, for long chipping materials, low feed rates	↓ 0.03 - 0.15	.0012 - .0059
.H. 	Grooving in "pecking process", profiling in partial cut, for long chipping	↓ 0.15 - 0.25	.0059 - .0098
		↔ 0.10 - 0.25	.0039 - .0098
.K./KF 	Grooving, side turning, finishing or profiling of grooves	↓ 0.05 - 0.25	.0020 - .0098
		↔ 0.05 - 0.25	.0020 - .0098
.L. 	Grooving in full and partial cut with excellent chip control	↓ 0.10 - 0.22	.0039 - .0087
		↔ 0.05 - 0.20	.0020 - .0079
.ZG. 	Grooving, side turning, profiling of grooves	↓ 0.10 - 0.22	.0039 - .0087
		↔ 0.05 - 0.20	.0020 - .0079

* Dependent upon insert width, edge radii, and material

↓ Grooving ↔ Turning

Geometry	Applications	Feed Rate	
		f (mm/rev)	f (ipr)
.10	Grooving, finishing of grooves, for long chipping materials, low feed rates	↓ 0.05 - 0.15	.0020 - .0059
.20	Grooving, finishing of grooves, geometry for inserts with profile, for short chipping materials and high tensile strength	↓ 0.07 - 0.25	.0028 - .0098
.3.	Grooving, side turning, profiling of grooves, suitable for materials with high tensile strength	↓ 0.15 - 0.25	.0059 - .0098
		↔ 0.15 - 0.40*	.0059 - .0157*
.5.	Grooving, side turning, profiling of grooves, excellent reduction of chip width in materials with medium tensile strength	↓ 0.10 - 0.45	.0039 - .0177
		↔ 0.15 - 0.60*	.0059 - .0236
.A.	Grooving, side turning, finishing or profiling of grooves, excellent chip breaking in materials with medium tensile strength	↓ 0.05 - 0.30	.0020 - .0118
		↔ 0.10 - 0.30*	.0039 - .0118
.C.	Parting off, for long chipping materials	↓ 0.02 - 0.10	.0008 - .0039
.E./EN	Grooving, side turning, profiling of grooves, suitable for materials with high tensile strength	↓ 0.08 - 0.30	.0031 - .0118
.F./FY	Grooving, finishing of grooves, for long chipping materials, low feed rates	↓ 0.03 - 0.15	.0012 - .0059
.H.	Grooving in "pecking process", profiling in partial cut, for long chipping	↓ 0.15 - 0.25	.0059 - .0098
		↔ 0.10 - 0.25	.0039 - .0098
.HR.	Grooving in full and partial cut with excellent chip control	↓ 0.20 - 0.30	.0079 - .0118
.L.	Grooving in full and partial cut with excellent chip control	↓ 0.10 - 0.22	.0039 - .0087
		↔ 0.05 - 0.20	.0020 - .0079
.K./KF	Grooving, side turning, finishing or profiling of grooves	↓ 0.05 - 0.25	.0020 - .0098
		↔ 0.05 - 0.25	.0020 - .0098
.N.	Grooving, side turning, finishing or profiling of grooves, excellent chip breaking in materials with medium tensile strength	↓ 0.05 - 0.25	.0020 - .0098
		↔ 0.05 - 0.20	.0020 - .0079

* Dependent upon insert width, edge radii, and material



Grooving



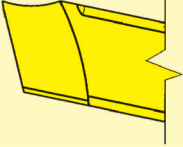
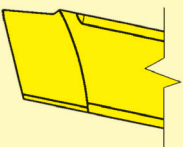
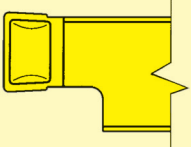

Turning

Geometry	Applications	Feed Rate	
		f (mm/rev)	f (ipr)
.10 	Grooving, finishing of grooves, for long chipping materials, low feed rates	↓ 0.02 - 0.12	.0008 - .0047
.20 	Grooving, finishing of grooves, geometry for inserts with profile, for short chipping materials and high tensile strength	↓ 0.02 - 0.12	.0008 - .0047
.3. 	Grooving, side turning, profiling and finishing of grooves, for long chipping materials with high tensile strength	↓ 0.15 - 0.25	.0059 - .0098
		↔ 0.15 - 0.4*	.0059 - .0157

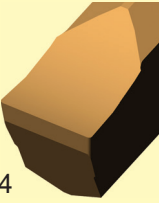

* Dependent upon insert width, edge radii, and material

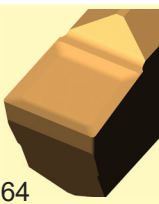
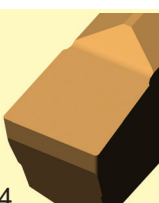
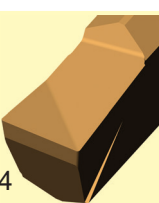
↓ Grooving ↔ Turning

Geometry	Applications	Feed Rate	
		f (mm/rev)	f (ipr)
.10  264	Grooving and parting off	↓ 0.02 - 0.08	.0008 - .0031
.20  264	Grooving and parting off for materials high tensile strength	↓ 0.02 - 0.08	.0008 - .0031
.D1  S264	Grooving and turning	↓ 0.03 - 0.13	.0012 - .0051
		↔ 0.05 - 0.20	.0020 - .0079
		$a_{p\ max} = 1.5 \times W$	
.M0  264	Grooving, turning and parting off for Brass (Ms58)	↓ 0.02 - 0.10	.0008 - .0039
		↔ 0.02 - 0.15	.0008 - .0059
.P.  264	Grooving and parting off	↓ 0.02 - 0.08	.0008 - .0031
		↔ 0.02 - 0.04	.0008 - .0016
		$a_{p\ max} = 1.5 \times W$	

↓ Grooving ↔ Turning

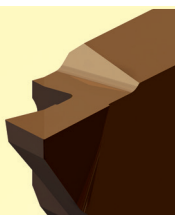

Geometry	Applications	Feed Rate	
		f (mm/rev)	f (ipr)
.10 	Grooving, finishing of grooves, for long chipping materials, low feed rates	↓ 0.02 - 0.12	.0008 - .0047
.M. 	Grooving, finishing of grooves, geometry for inserts with profile, for short chipping materials and high tensile strength	↓ 0.02 - 0.12	.0008 - .0047
.P. 	Grooving and turning (in one direction)	↓ 0.02 - 0.10	.0008 - .0039
		↔ 0.02 - 0.10	.0008 - .0039

↓ Grooving ↔ Turning

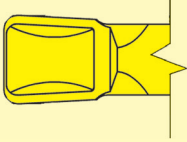
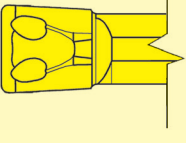
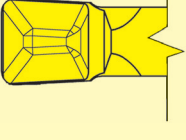
Geometry	Applications	Feed rate	
		f (mm/rev)	f (ipr)
.3. 	Grooving, side turning, profiling and finishing of grooves, for long chipping materials with high tensile strength	↓ 0.15 - 0.25	.0059 - .0098
		↔ 0.15 - 0.40*	.0059 - .0157
.5. 	Grooving, side turning, profiling of grooves, excellent reduction of chip width in materials with medium tensile strength	↓ 0.08 - 0.25	.0031 - .0098
		↔ 0.10 - 0.20*	.0039 - .0079
.D. 	Grooving, profiling of grooves, suitable for materials with high tensile strength	↓ 0.03 - 0.15	.0012 - .0059
		↔ 0.05 - 0.20	.0020 - .0079

* Dependent upon insert width, edge radii and material



↓ Grooving ↔ Turning

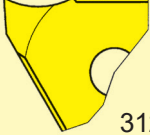
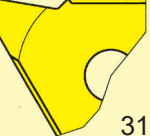
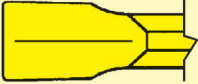
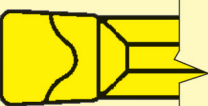
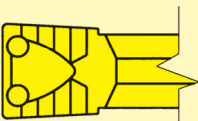
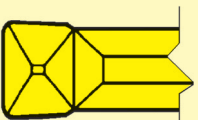
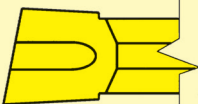

Geometry	Applications	Feed Rate	
		f (mm/rev)	f (ipr)
.00  312	Grooving, finishing of grooves, for long chipping materials, low feed rates	↓ 0.02 - 0.12	.0008 - .0047
Chipbreaker for special inserts  312	Grooving, finishing of grooves, geometry for inserts with profile, for short chipping materials and high tensile strength	↓ 0.02 - 0.12	.0008 - .0047
.V.  312	Grooving, with excellent chip control	↓ 0.04 - 0.15	.0016 - .0059
.F.  S312	Grooving, profiling of grooves, easy cut	↓ 0.03 - 0.15	.0012 - .0059
.5.  S312	Grooving, side turning, profiling of grooves, excellent reduction of chip width in materials with medium tensile strength	↓ 0.08 - 0.25	.0031 - .0098
		↔ 0.10 - 0.20*	.0039 - .0079
.D.  S312	Grooving, profiling of grooves, suitable for materials with high tensile strength	↓ 0.03 - 0.15	.0012 - .0059
		↔ 0.05 - 0.20	.0020 - .0079
.C.  S312	Parting off, grooving	↓ 0.02 - 0.10	.0008 - .0039

* Dependent upon insert width, edge radii, and material

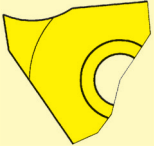
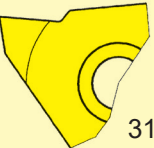
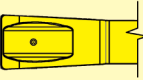
↓ Grooving ↔ Turning

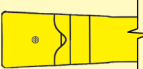
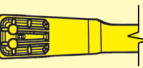
Geometry	Applications	Feed Rate	
		f (mm/rev)	f (ipr)
.00  315	Grooving, finishing of grooves, for long chipping materials, low feed rates	↓ 0.02 - 0.12	.0008 - .0047
Chipbreaker for special inserts  315	Grooving, finishing of grooves, geometry for inserts with profile, for short chipping materials and high tensile strength	↓ 0.02 - 0.12	.0008 - .0047
.EN.  S315	Grooving, side turning, profiling of grooves, suitable for materials with high tensile strength	↓ 0.08 - 0.15	.0031 - .0059
.FL.  S315	Grooving, finishing of grooves, for long chipping materials, "low feed rates" with excellent chip control	↓ 0.03 - 0.15	.0012 - .0059
.FY.  S315	Grooving, finishing of grooves, for long chipping materials, "low feed rates" with excellent chip control	↓ 0.03 - 0.15	.0012 - .0059
		↔ 0.03 - 0.15	.0012 - .0059
.L.  S315	Grooving in full and partial cut with excellent chip control	↓ 0.10 - 0.15	.0039 - .0059
		↔ 0.05 - 0.10	.0020 - .0039

↓ Grooving ↔ Turning

V

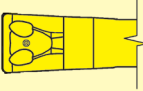
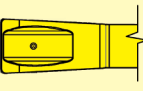
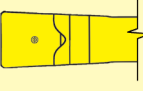
Geometry	Applications	Feed Rate	
		f (mm/rev)	f (ipr)
.5. 	Grooving, side turning, profiling of grooves, excellent reduction of chip width in materials with medium tensile strength	↓ 0.06 - 0.25	.0024 - .0098
.EN. 	Grooving, side turning, profiling of grooves, suitable for materials with high tensile strength	↓ 0.08 - 0.20	.0031 - .0078
.FY. 	Grooving, finishing of grooves, for long chipping materials, "low feed rates" with excellent chip control	↓ 0.03 - 0.15	.0012 - .0059

↓ Grooving ↔ Turning

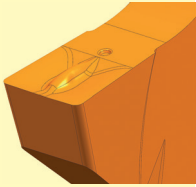
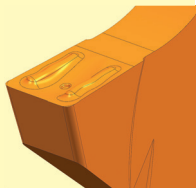
Geometry	Applications	Feed Rate	
		f (mm/rev)	f (ipr)
.1A 	Grooving, finishing of grooves, for long chipping materials, low feed rates	↓ 0.03 - 0.12	.0012 - .0047
.DL 	Grooving, side turning, finishing or profiling of grooves	↓ 0.05 - 0.15	.0020 - .0059
		↔ 0.05 - 0.20	.0020 - .0079

↓ Grooving ↔ Turning

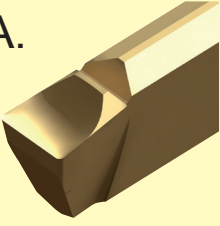

Geometry	Applications	Feed Rate	
		f (mm/rev)	f (ipr)
.WA. 	Grooving and parting off, finishing of grooves, easy cut	↓ 0.07 - 0.25	.0028 - .0098
		↓	Grooving ↔ Turning

Cutting Data .WA. Geometry

Material		Hardness Brinell (HB)	Cutting Speed, V_c			
			K10	unit	DD26	unit
N	Al-alloys	Non Heat Treatable 30-80	1000 - 600	m/min	1000 - 600	m/min
			3281 - 1969	sfm	3281-1969	sfm
	Heat treatable 80-120	400 - 220	m/min	400 - 220	m/min	
		1312 - 722	sfm	1312 - 722	sfm	
	Al-cast-alloy	Non heat treatable 80	1000 - 600	m/min	1000 - 600	m/min
			3281 - 1969	sfm	3281 - 1969	sfm
Heat treatable 100		600 - 300	m/min	600 - 300	m/min	
		1969 - 984	sfm	1969 - 984	sfm	

V

Geometry	Applications	Feed Rate f (mm/rev)	Feed Rate f (ipr)	Insert Types and Lead Angles								
				S100	S123/S223	S274	S264	S224	229/S229	312/S312	S315	S316
.00	Parting off	0.02 - 0.10	.0008 - .0039							0°		
		0.02 - 0.08	.0008 - .0031							5°		
	Tubes with small thickness	0.02 - 0.06	.0008 - .0024					8°		8°		
		0.02 - 0.05	.0008 - .0020			15°	15°			12°		
.00	Parting off with chip former	0.02 - 0.15	.0008 - .0059							0°		
		0.02 - 0.15	.0008 - .0059							5°		
.M.	Parting off brittle materials (MS58)	0.02 - 0.15	.0008 - .0059							0°	0°	
		0.02 - 0.15	.0008 - .0059							5°		
		0.02 - 0.12	.0008 - .0047					8°				
		0.02 - 0.10	.0008 - .0039					15°				
.V.	Parting off with chip forming	0.02 - 0.12	.0008 - .0047							0°		
		0.02 - 0.08	.0008 - .0031							5°		
.3V.	Parting off	0.05 - 0.2	.0020 - .0079	0°								
.C.	Parting off	0.02 - 0.10	.0008 - .0039		0°			0°	0°	0°		
		0.02 - 0.08	.0008 - .0031		4°			5°	5°	5°		
		0.02 - 0.06	.0008 - .0024		8°			8°	8°	8°		
		0.02 - 0.05	.0008 - .0020		15°			15°				
.E.	Parting off	0.02 - 0.12	.0008 - .0047	0°				0°	0°			
		0.05 - 0.12	.0020 - .0047	5°				5°				
.EN	Parting off	0.10 - 0.25	.0039 - .0098	0°				0°	0°		0°	
		0.10 - 0.20	.0039 - .0079	5°								
*.D. (.32)	Parting off	0.02 - 0.10	.0008 - .0039		0°			0°		0°		
.F.	Parting off	0.02 - 0.12	.0008 - .0047	0°				0°	0°			
		0.02 - 0.10	.0008 - .0039	5°				5°				
.3.	Parting off	0.10 - 0.15	.0039 - .0059					0°	0°			
		0.08 - 0.12	.0031 - .0047						5°			
.N.	Parting off	0.05 - 0.2	.0020 - .0079	0°					0°			

* Only inserts S123 / S223

Cutting Data ISO Material Group P, M and K Metric



Material			Hardness Brinell (HB)	Cutting Speed v_c (m/min)								
				K10	EG35 EG55	HP65 HP66	IG35* IG36*	TH35 TH36	AS45 AS46 AS62 AS65 AS66	DD26	HS35 HS36	H20 H54
P	Carbon steel	0,2% C	140		255 280-180	190 200-160		265 300-160	285 320-180			215 230-170
		0,4% C	180		225 250-140	170 180-150		235 270-130	255 290-150			205 220-160
		0,6% C	200		200 230-120	170 180-140		200 230-100	220 250-130			195 210-150
	Alloyed steel (<5%)	annealed	180		190 220-100	170 180-140		200 220-90	200 230-100			195 210-150
		quenched	280		180 210-90	140 160-90		180 200-80	190 220-90			155 170-120
		quenched	350		165 190-80	130 140-90		150 180-80	170 200-80			125 140-80
	high alloyed steel (>5%)	annealed	200		190 210-140	145 160-100		180 200-120	200 220-140			115 120-100
		hardened	-		125 140-70						125 140-70	
	Cast steel	unalloyed	180		185 200-140	160 180-120		180 200-140	190 200-150			165 180-120
		alloyed	220		145 160-100	135 150-90		140 160-90	145 160-100			130 140-90
M	Stainless steel	martensitic, ferritic	200		125 130-100	100 120 - 80	100 120 - 80				145 180-120	175 190-120
		austenitic	180			90 120 - 70	90 120 - 70				130 140-100	160 170-120
K	Grey cast iron	low tensile strength	180	90-60	180 200-120			160 180-120	180 200-120			
		high tensile strength	250	90-60	150 160-120			140 150-120	150 160-120			
	Spheroidal graphite cast iron	ferritic	160		170 180-130			160 180-120	170 180-130			
		perlitic	250		150 160-120			140 150-110	150 160-120			
	Malleable cast iron	ferritic	125		200 220-120			180 200-100	200 220-120			
		perlitic	225		170 190-100			160 180-90	170 190-100			

Notes:

- * Alternative: TI25 or TI26
- Reduction of the cutting speed for axial grooving to 75%.
- Reduction of the cutting speed of the 15A/25A system to 50%.
- Reduction of the cutting speed during form cutting to 75%.
- Cutting materials with suffix 2 or 6 => tendency to higher cutting speed
- Cutting materials with suffix 5 => tendency to lower cutting speed

Cutting Data ISO Material Group N & S Metric



Material			Hardness Brinell (HB)	Cutting Speed v_c (m/min)								
				K10	EG35 EG55	HP65 HP66	IG35* IG36*	TH35 TH36	AS45 AS46 AS62 AS65 AS66	DD26	HS35 HS36	H20 H54
N	Al-alloys	non heat treatable	30-80	1000-600						900 1000-600		
		heat treatable	80-120	400-220						350 400-220		
	Al-cast-alloy	non heat treatable	80	1000-600						900 1000-600		
		heat treatable	100	600-300						520 600-300		
	Copper-alloys	non heat treatable	90	200-120						190 210-130		
		heat treatable	100	150-90						145 160-90		
S	Heat resistant alloy (Fe)	annealed	200			85 100-40					85 100-40	
		hardened	275			65 80-30					65 80-30	
	Heat resistant alloy (Ni, Co)	annealed	250			55 70-20					55 70-20	
		hardened	350			45 60-10					45 60-10	
	Titanium pure		100			70 90 - 60						
	Titanium alloys		266			70 90 - 60						

Notes:

- * Alternative: TI25 or TI26
- Reduction of the cutting speed for axial grooving to 75%.
- Reduction of the cutting speed of the 15A/25A system to 50%.
- Reduction of the cutting speed during form cutting to 75%.
- Cutting materials with suffix 2 or 6 => tendency to higher cutting speed
- Cutting materials with suffix 5 => tendency to lower cutting speed

V

Cutting Data ISO Material Group P, M and K Imperial



Material		Hardness Brinell (HB)	Cutting Speed v_c (sfm)								
			K10	EG35 EG55	HP65 HP66	IG35* IG36*	TH35 TH36	AS45 AS46 AS62 AS65 AS66	DD26	HS35 HS36	H20 H54
P	Carbon steel	0,2% C	140	837 919-591	623 656-525		869 984-525	935 1050-591			705 755-558
		0,4% C	180	738 820-459	558 591-492		771 886-427	837 951-492			673 722-525
		0,6% C	200	656 755-394	558 591-459		656 755-328	722 820-427			640 689-492
	Alloyed steel (<5%)	annealed	180	623 722-328	558 591-459		656 722-295	656 755-328			640 689-492
		quenched	280	591 689-295	459 525-295		591 656-262	623 722-295			509 558-394
		quenched	350	541 623-262	427 459-295		492 591-262	558 656-262			410 459-262
	High alloyed steel (>5%)	annealed	200	623 689-459	476 525-328		591 656-394	656 722-459			377 394-328
		hardened	-	410 459-230						410 459-230	
	Cast steel	unalloyed	180	607 656-459	525 591-394		591 656-459	623 656-492			541 591-394
		alloyed	220	476 525-328	443 492-295		459 525-295	476 525-328			427 459-295
M	Stainless steel	martensitic, ferritic	200	410 427-328	328 394 - 262	328 394 - 262				476 591-394	574 623-394
		austenitic	180		295 394 - 230	295 394 - 230				427 459-328	525 558-394
K	Grey cast iron	low tensile strength	180	295-197	591 656-394			525 591-394	591 656-394		
		high tensile strength	250	295-197	492 525-394			459 492-394	492 525-394		
	Spheroidal graphite cast iron	ferritic	160		558 591-427			525 591-394	558 591-427		
		perlitic	250		492 525-394			459 492-361	492 525-394		
	Malleable cast iron	ferritic	125		656 722-394			591 656-328	656 722-394		
		perlitic	225		558 623-328			525 591-295	558 623-328		

Notes:

- * Alternative: TI25 or TI26
- Reduction of the cutting speed for axial grooving to 75%.
- Reduction of the cutting speed of the 15A/25A system to 50%.
- Reduction of the cutting speed during form cutting to 75%.
- Cutting materials with suffix 2 or 6 => tendency to higher cutting speed
- Cutting materials with suffix 5 => tendency to lower cutting speed

Material		Hardness Brinell (HB)	Cutting Speed v_c (sfm)									
			K10	EG35 EG55	HP65 HP66	IG35* IG36*	TH35 TH36	AS45 AS46 AS62 AS65 AS66	DD26	HS35 HS36	H20 H54	
N	Al-alloys	non heat treatable	30-80	3281-1969						2953 3281-1969		
		heat treatable	80-120	1312-722						1148 1312-722		
	Al-cast-alloy	non heat treatable	80	3281-1969						2953 3281-1969		
		heat treatable	100	1969-984						1706 1969-984		
	Copper-alloys	non heat treatable	90	656-394						623 689-427		
		heat treatable	100	492-295						476 525-295		
S	Heat resistant alloy (Fe)	annealed	200			279 328-131					279 328-131	
		hardened	275			213 262-98					213 262-98	
	Heat resistant alloy (Ni, Co)	annealed	250			180 230-66					180 230-66	
		hardened	350			148 197-33					148 197-33	
	Titanium pure		100			230 295 - 197						
	Titanium alloys		266			230 295 - 197						

Notes:

- * Alternative: TI25 or TI26
- Reduction of the cutting speed for axial grooving to 75%.
- Reduction of the cutting speed of the 15A/25A system to 50%.
- Reduction of the cutting speed during form cutting to 75%.
- Cutting materials with suffix 2 or 6 => tendency to higher cutting speed
- Cutting materials with suffix 5 => tendency to lower cutting speed

Description Carbide Grades



HORN-Grades	ISO513	Properties	Materials	Recommended Applications
H20	HT	Cermet	P M K S Carbon steels, low alloy steels, cast steel, stainless steel, exotic alloys	for grooving and finishing, for high quality surface finish, no tendency for built up edge, resistant to wear
K10	HW	Uncoated	N Aluminium and copper alloys	for grooving and finishing
MG12	HF	Uncoated (micro grain)	N Aluminium and copper alloys	for grooving and finishing, at low cutting speed, unfavorable conditions
AS62	HC	AlTiN	P All types of steel and cast steel	for grooving and finishing at medium cutting speed
TH36 AS46 AS66	HC	AlTiN	P All types of steel and cast steel	for grooving and finishing, at very high cutting speed, heat resistant, suitable for dry cutting
EG35 EG55	HC	AlTiN + TiN	P All types of steel and cast steel, excluding stainless steel with austenitic structure	for grooving and finishing at high cutting speed
TH35 AS6G	HC	AlTiN	P All types of steel and cast steel	for grooving and finishing at high cutting speed
HP65 HP66	HC	AlTiN	P M All types of steel and cast steel martensitic stainless steel	for grooving and finishing at medium cutting speed, heat resistant
IG35 IG36	HC	AlTiSiN	P M Stainless, austenitic steel and austenitic-ferritic steel and cast steel as well as superalloys and titanium	for grooving and finishing, at high cutting speed, heat resistant, suitable for dry cutting
DD25 DD26	HC	Titanium diboride	N Alloyed non-ferrous metals such as aluminium alloys or unleaded brass	for grooving and finishing at very high cutting speed, heat resistant
HS35 HS36	HC	AlTiSiN	S Heat resistant, difficult to machine superalloys with high contents of iron, nickel, cobalt and/or titanium	for grooving and finishing, at high cutting speed, heat resistant, suitable for dry cutting

PCD- or PCBN-tipped inserts upon request.

Carbide grades in stock are shown in the catalogue or in the price and stock list. Grades not listed can be supplied only made to order.

Cutting Conditions CB07, CB10 & CB50



Material	Material Condition	Cutting Speed, V_c (m/min)								
		Full Width Groove $f = 0.03 - 0.04$ mm/rev			Partial Cut			Finishing $a_p = 0.1 - 0.2$ mm $f = 0.04 - 0.08$ mm/rev		
		CB07	CB10	CB50	CB07	CB10	CB50	CB07	CB10	CB50
H	Hard Steel > 56 HRC, Continuous Cut	150	140					160	150	
	Hard Steel > 45 HRC, Interrupted cut			140						150
K		Full Width Groove $f = 0.1 - 0.25$ mm/rev			Partial Cut $a_p = 0.3 - 1.0$ mm $f = 0.2 - 0.4$ mm/rev					
	Grey Cast Iron, Pearlitic			1200			1300			
		Full Width Groove $f = 0.07 - 0.2$ mm/rev			Partial Cut $a_p = 0.1 - 0.7$ mm $f = 0.1 - 0.3$ mm/rev					
	Spheroidal Graphite Cast Iron			900			1000			

Material	Material Condition	Cutting Speed, V_c (sfm)								
		Full Width Groove $f = .0012 - .0016$ ipr			Partial Cut			Finishing $a_p = .0039 - .0079$ in $f = .0016 - .0031$ ipr		
		CB07	CB10	CB50	CB07	CB10	CB50	CB07	CB10	CB50
H	Hard Steel > 56 HRC, Continuous Cut	492	459					525	492	
	Hard Steel > 45 HRC, Interrupted cut			459						492
K		Full Width Groove $f = .0039 - .0098$ ipr			Partial Cut $a_p = .0118 - .0394$ in $f = .0079 - .0157$ ipr					
	Grey Cast Iron, Pearlitic			3937			4265			
		Full Width Groove $f = .0028 - .0079$ ipr			Partial Cut $a_p = .0039 - .0276$ in $f = .0039 - .0118$ ipr					
	Spheroidal Graphite Cast Iron			2953			3281			





V

105

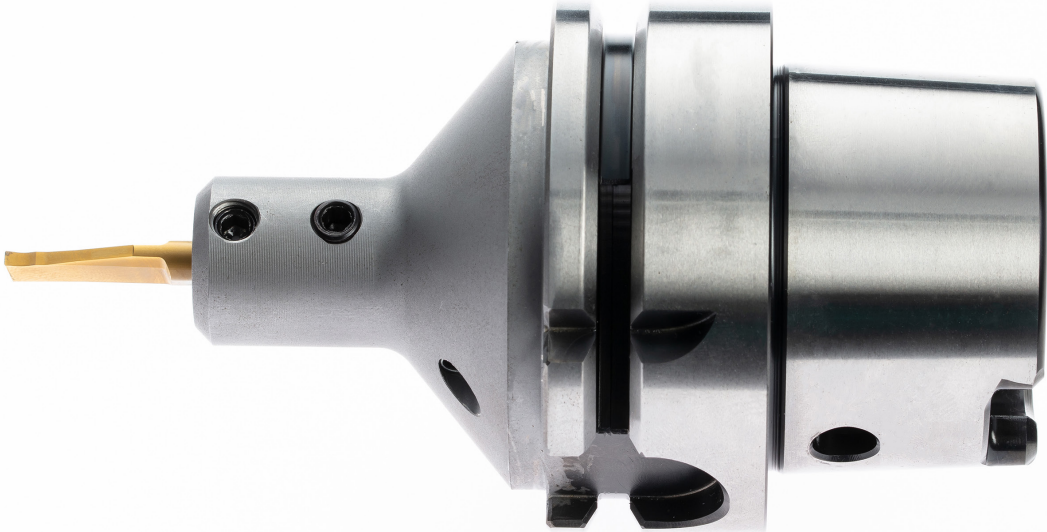

Toolholder with Inserts

W

Toolholder
SB105.HSK/SB105

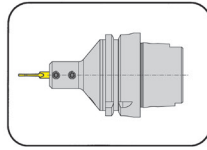

Page
W3-W4

Insert
P105

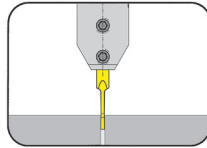

Page
W5

W

Toolholder

SB105.HSK

with through coolant supply

HORN HSKT63 according to ISO 12164-3

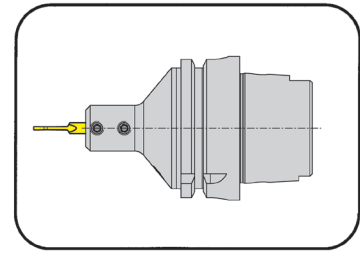

for Indexable insert

Type P105

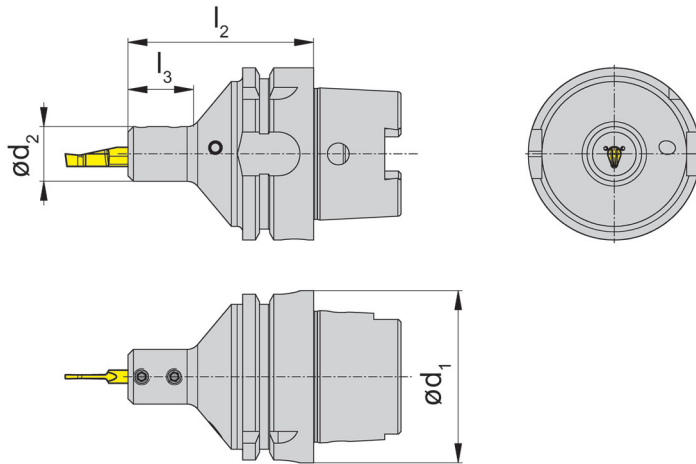

Part number	d ₁	d ₂	l ₂	l ₃
SB105.HSK63.02.IK	63	20	68	24

Further sizes upon request

Dimensions in mm

W

Spare Parts

Toolholder	Clamping Screw	Coolant pipe	TORX PLUS® Wrench
SB105.HSK63.02.IK	6.075T15P	020.6318.1308	T15PQ

Toolholder

SB105

with through coolant supply

for Insert P105 with extended clamping shank

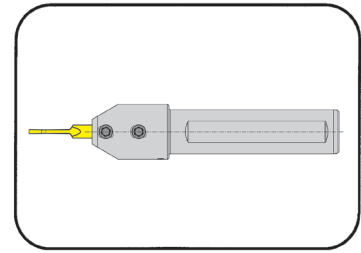

for Insert

Type P105

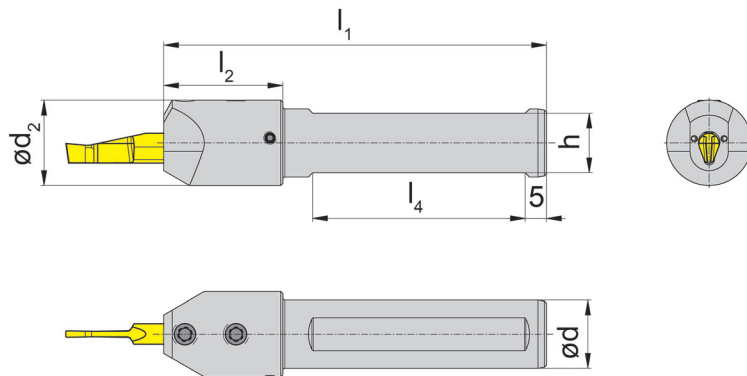

Part number	d	d ₂	l ₁	l ₂	l ₄	h
SB105.0016.02.IK	16	20	90	28	50	14
SB105.0020.02.IK	20	20	90	-	50	18
SB105.0025.02.IK	25	25	90	-	50	23

Further sizes upon request

Dimensions in mm



Spare Parts

Toolholder	Clamping Screw	Threaded Pin	TORX PLUS® Wrench
SB105...	6.075T15P	3.03.913	T15PQ

W4

Call Us Toll Free (888) 818-4676

Insert

P105

Curve radius 2.953"

Clamping length .866"

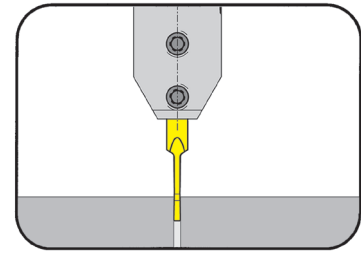

for Toolholder

Type SB105
SB105.HSK...

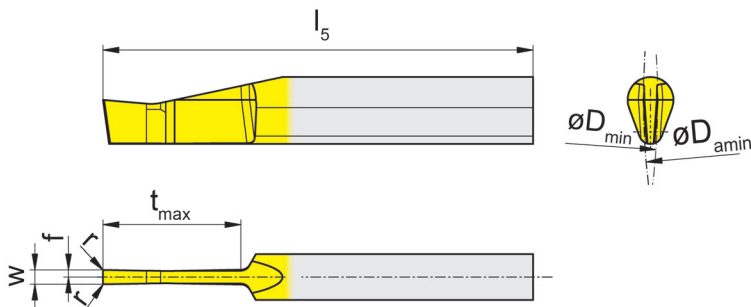

Part number	w	r	f	b	l_5	t_{max}	D_{min}	$D_{a min}$	EG35
P105.1515.12.75.01	.059	.006	.030	.189	1.772	.472	5.906	5.906	▲
P105.2020.16.75.01	.079	.008	.039	.189	1.772	.630	5.906	5.906	▲
P105.2520.22.75.01	.098	.008	.089	.189	1.969	.866	5.906	5.906	▲
P105.3025.25.75.01	.118	.010	.059	.189	2.165	.984	5.906	5.906	▲
P105.3525.30.75.01	.138	.010	.069	.189	2.362	1.181	5.906	5.906	▲
P105.4025.35.75.01	.157	.010	.079	.189	2.559	1.378	5.906	5.906	▲

▲ on stock Δ 4 weeks x upon request

● recommended

o alternative recommendation

- not suitable

□ uncoated grades

■ coated grades

■ brazed/Cermet

Dimensions in inch

Further sizes upon request

P	•
M	•
K	o
N	-
S	-
H	-

Carbide grades

W



W



System
105/110
117

Page
X2
X40

X

Toolholder
SB105/SB110/B105

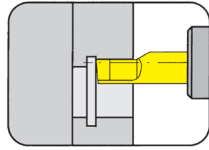

Page
X4-X17

Insert
NU105/N105

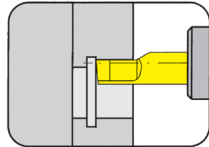

Page
X18-X38

105/110



Toolholder with Inserts

Bore Ø from .236"

X

Toolholder

SBU105

Bore Ø from .236"

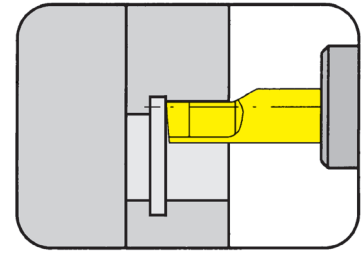

for Insert

Type N105
NU105

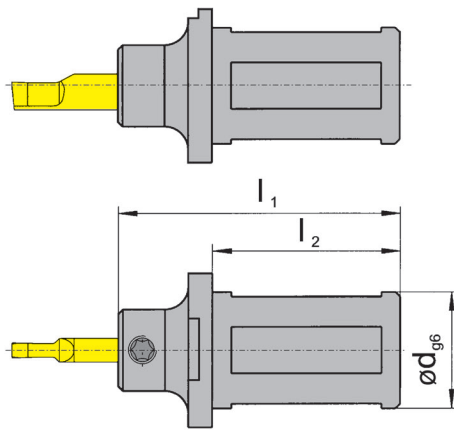

Part number	d	l ₁	l ₂	D _{min}
SBU105.0750.1.01	.750	2.874	1.969	.236
SBU105.1000.1.01	1.000	2.874	1.969	.236

Further sizes upon request

Dimensions in inch

Clamping length of inserts = .472"

For torque specification of the screw, please see Technical Instructions.



Spare Parts

Toolholder	Clamping Screw	TORX PLUS® Wrench
SBU105...	6.075T15P	T15PQ

X4

Toolholder

SB105

Bore Ø from 6 mm

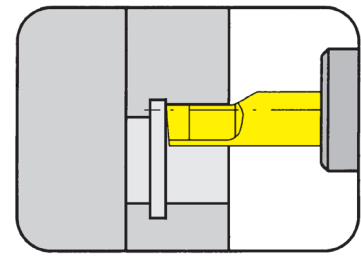

for Insert

Type N105
NU105

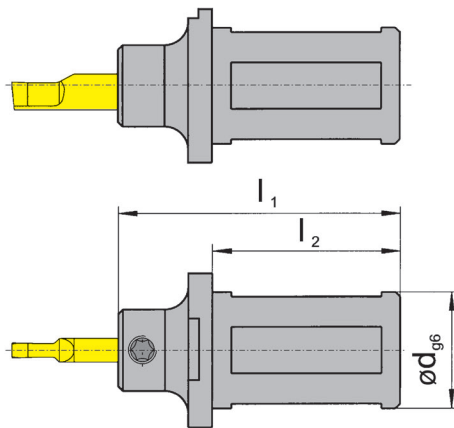

Part number	d	l ₁	l ₂	D _{min}
SB105.0016.1.01	16	73	50	6
SB105.0020.1.01	20	73	50	6
SB105.0022.1.01	22	73	50	6
SB105.0025.1.01	25	73	50	6
SB105.0032.1.01	32	73	50	6

Further sizes upon request

Dimensions in mm

Clamping length of inserts = 12 mm!

For torque specification of the screw, please see Technical Instructions.

Spare Parts

Toolholder	Clamping Screw	TORX PLUS® Wrench
SB105...	6.075T15P	T15PQ

Toolholder

SBU105

Bore Ø from .236"

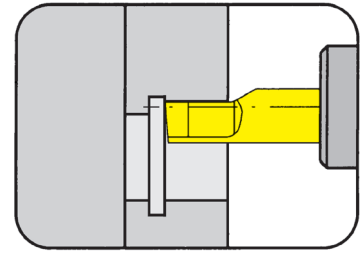

for Insert

Type N105
NU105

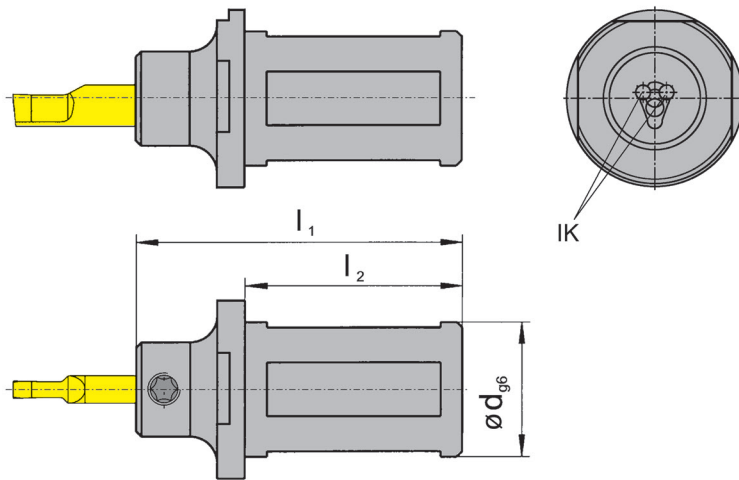

Internal Coolant

Part number	d	l ₁	l ₂	D _{min}
SBU105.0750.1.01.IK	.750	2.874	1.969	.236
SBU105.1000.1.01.IK	1.000	2.874	1.969	.236
SBU105.1250.1.01.IK	1.250	2.874	1.969	.236

Further sizes upon request

Dimensions in inch

Clamping length of inserts = .472"

For torque specification of the screw, please see Technical Instructions.



Spare Parts

Toolholder	Clamping Screw	TORX PLUS® Wrench
SBU105...	6.075T15P	T15PQ

X6

Call Us Toll Free (888) 818-4676

Toolholder

SB105

Bore Ø from 6 mm

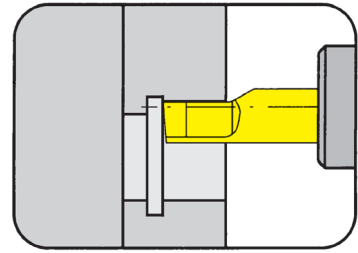

for Insert

Type N105
NU105

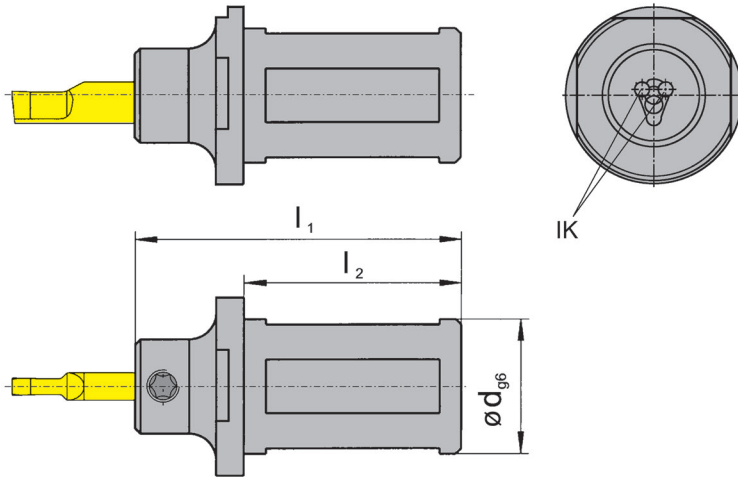

Internal Coolant

Part number	d	l ₁	l ₂	D _{min}
SB105.0016.1.01.IK	16	73	50	6
SB105.0020.1.01.IK	20	73	50	6
SB105.0022.1.01.IK	22	73	50	6
SB105.0025.1.01.IK	25	73	50	6
SB105.0032.1.01.IK	32	73	50	6

Further sizes upon request

Dimensions in mm

Clamping length of inserts = 12 mm!

For torque specification of the screw, please see Technical Instructions.

Spare Parts

Toolholder	Clamping Screw	TORX PLUS® Wrench
SB105...	6.075T15P	T15PQ



Toolholder

SB105/SB110

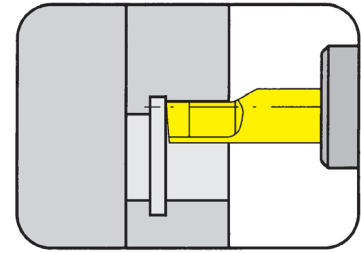

Bore Ø from 6 mm

only usable for broaching devices EWSP20, BENZ LinA 4.0 with IK

for Insert

Type N105
 NU105
 N110
 NU110

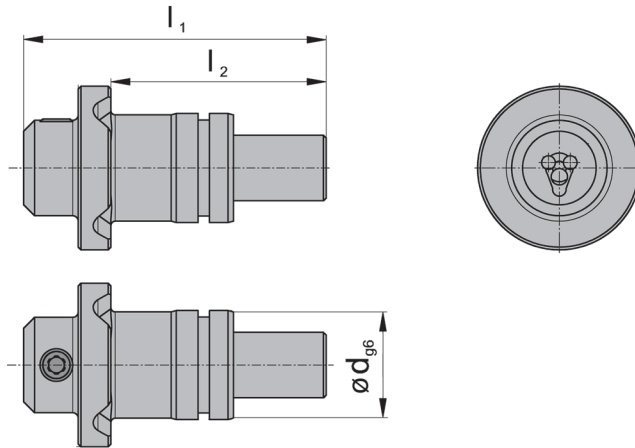

Clamping length of inserts
 Type 105 = 12 mm
 Type 110 = 26 mm

Picture = System SB105

Part number	d	l ₁	l ₂	D _{min}
SB105.0020.E5.01.IK	20	55.5	39.5	6
SB110.0020.E5.02.IK	20	70.0	39.5	9

Further sizes for other device interfaces upon request

Dimensions in mm

For torque specification of the screw, please see Technical Instructions.



Spare Parts

Toolholder	Clamping Screw	TORX PLUS® Wrench
SB105...	6.075T15P	T15PQ

X8

Call Us Toll Free (888) 818-4676

Toolholder

SB105/SB110

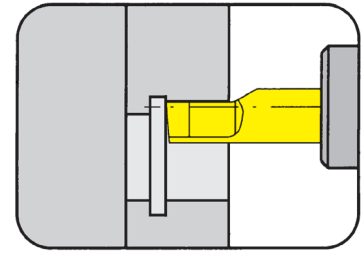

Bore \varnothing from 6 mm

only usable for broaching devices EWS-Slot, BENZ LinA, Sauter

for Insert

Type N105
 NU105
 N110
 NU110

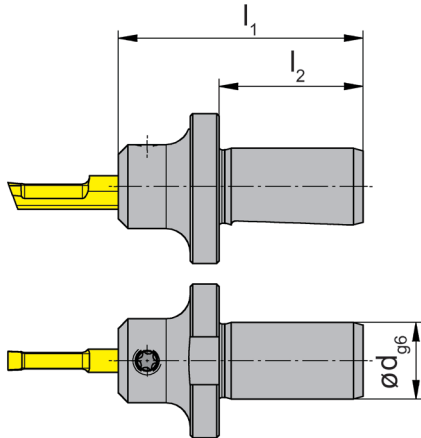

Clamping length of inserts
 Type 105 = 12 mm
 Type 110 = 26 mm

Picture = System SB105

Part number	d	l ₁	l ₂	D _{min}
SB105.0016.E1.01	16	51	30	6
SB110.0016.E1.02	16	72	30	9

Further sizes for other device interfaces upon request

Dimensions in mm

For torque specification of the screw, please see Technical Instructions.

Spare Parts

Toolholder	Clamping Screw	TORX PLUS® Wrench
SB105...	6.075T15P	T15PQ



Toolholder

B105



for broaching device Schwarzer

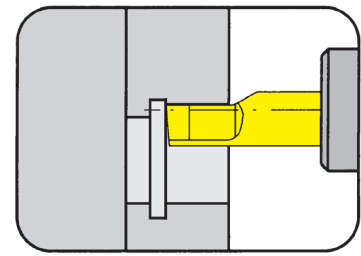

for Insert

Type N105
NU105

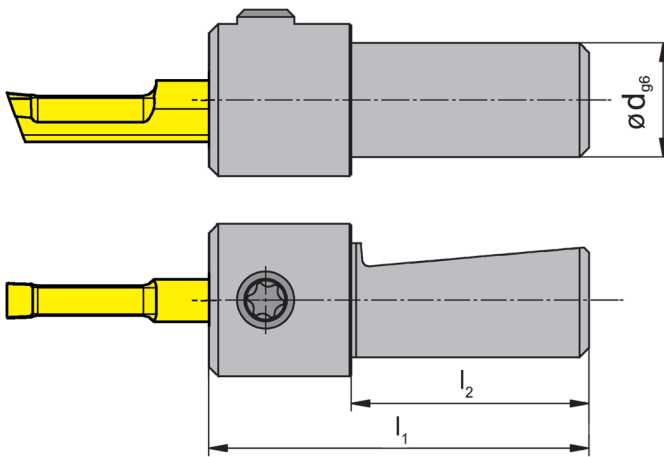

Part number	d	l ₁	l ₂	D _{min}
B105.0012.0220	12	40	25	6

Further sizes for other device interfaces upon request

Dimensions in mm

Clamping length of inserts = 12 mm!

For torque specification of the screw, please see Technical Instructions.



Spare Parts

Toolholder	Clamping Screw	TORX PLUS® Wrench
B105.0012.0220	6.075T15P	T15PQ

X10

Call Us Toll Free (888) 818-4676

Toolholder

SB105/SB110



for broaching device WTO

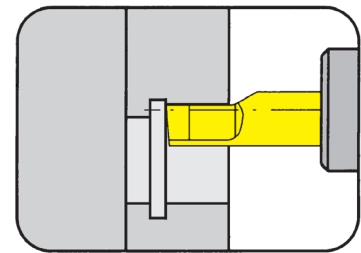

for Insert

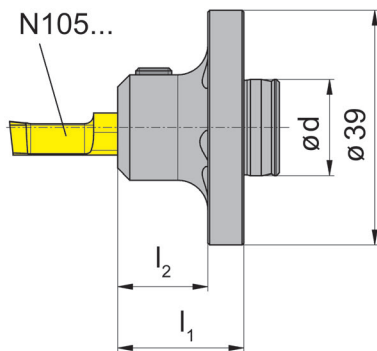

Type N105
 NU105
 N110
 NU110

Clamping length of inserts
 Type 105 = 12 mm
 Type 110 = 26 mm

Picture = System SB105

Part number	d	l ₁	l ₂	D _{min}
SB105.1816.W1.01	16	21	15	6
SB110.2016.W1.02	16	42	36	9

Further sizes for other device interfaces upon request

Dimensions in mm

For torque specification of the screw, please see Technical Instructions.

Spare Parts

Toolholder	Clamping Screw	TORX PLUS® Wrench
SB105...	6.075T15P	T15PQ



Toolholder

SB105/SB110

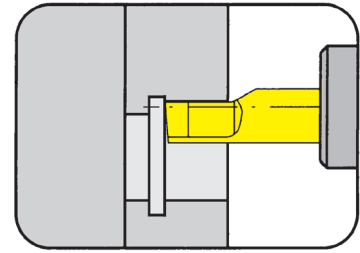

Bore Ø from 6 mm

for broaching device Schwarzer „2in1“

for Insert

Type N105
NU105
N110
NU110

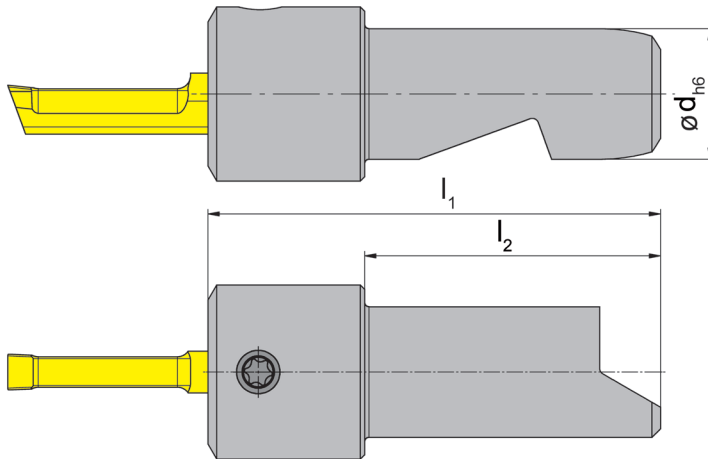

Picture = System SB105

Clamping length of inserts
Type 105 = 12 mm
Type 110 = 26 mm

Part number	d	l ₁	l ₂	D _{min}
SB105.0015.S1.01	15	52	34	6
SB110.0015.S1.02	15	66	34	9

Further sizes for other device interfaces upon request

Dimensions in mm

For torque specification of the screw, please see Technical Instructions.



Spare Parts

Toolholder	Clamping Screw	TORX PLUS® Wrench
SB105...	6.075T15P	T15PQ

Toolholder

SB105/SB110

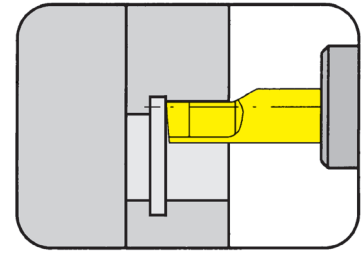

Bore Ø from 6 mm

for broaching device AP2R/AP3R

for Insert

Type N105
 NU105
 N110
 NU110

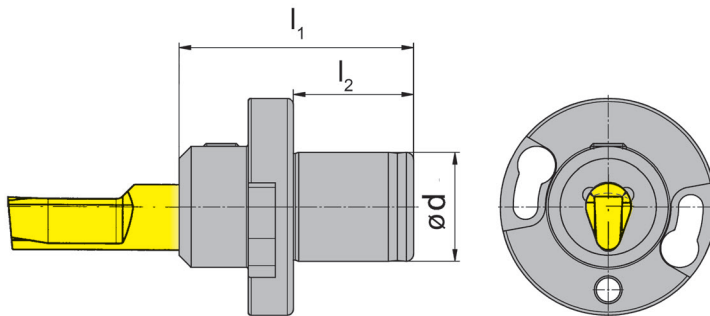

Clamping length of inserts
 Type 105 = 12 mm
 Type 110 = 26 mm

Picture = System SB105

Part number	d	l ₁	l ₂	D _{min}
SB105.0018.A.01	18	38	20	6
SB110.0018.A.01	18	39	20	6
SB110.0018.A.02	18	52	20	6

Further sizes for other device interfaces upon request

Dimensions in mm

For torque specification of the screw, please see Technical Instructions.

Spare Parts

Toolholder	Clamping Screw	TORX PLUS® Wrench
SB105...	6.075T15P	T15PQ



Toolholder

SBU110

Bore Ø from .354"

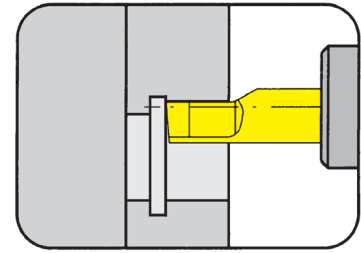

for Insert

Type N110
NU110

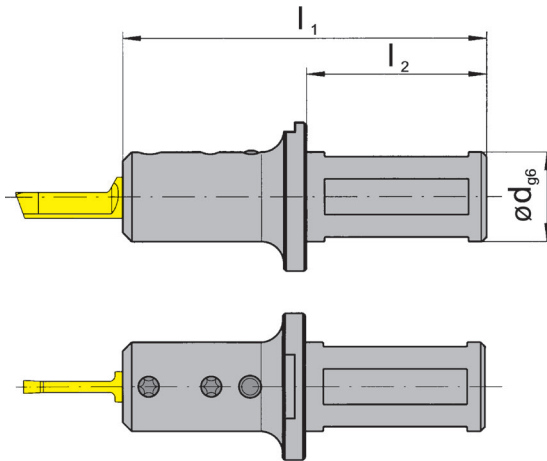

Part number	d	l ₁	l ₂	D _{min}
SBU110.0750.1.02	.750	3.465	1.969	.354
SBU110.1000.1.02	1.000	3.465	1.969	.354
SBU110.1250.1.02	1.250	3.465	1.969	.354

Further sizes upon request

Dimensions in inch

Clamping length of inserts = 1.024"

For torque specification of the screw, please see Technical Instructions.



Spare Parts

Toolholder	Clamping Screw	TORX PLUS® Wrench
SBU110...	6.075T15P	T15PQ

Toolholder

SB110

Bore \varnothing from 9 mm

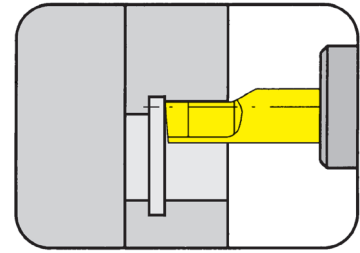

for Insert

Type N110
NU110

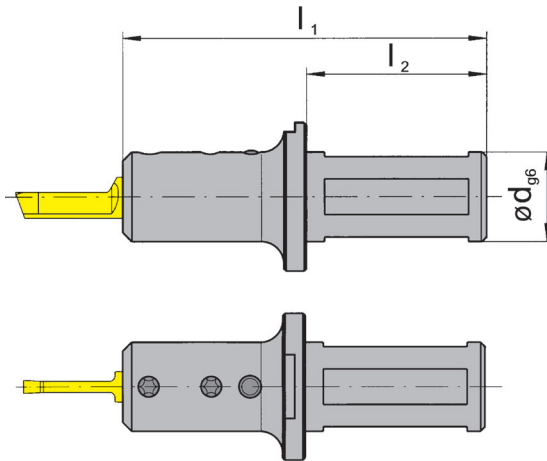

Part number	d	l_1	l_2	D_{min}
SB110.0020.1.02	20	88	50	9
SB110.0025.1.02	25	88	50	9
SB110.0032.1.02	32	88	50	9

Further sizes upon request

Dimensions in mm

Clamping length of inserts = 26 mm!

For torque specification of the screw, please see Technical Instructions.

Spare Parts

Toolholder	Clamping Screw	TORX PLUS® Wrench
SB110...	6.075T15P	T15PQ

Toolholder

SBU110

Bore Ø from .354"

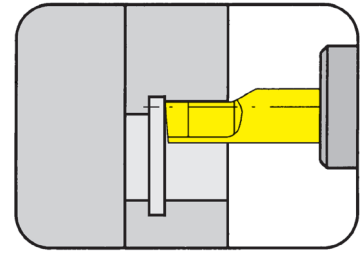

for Insert

Type N110
NU110

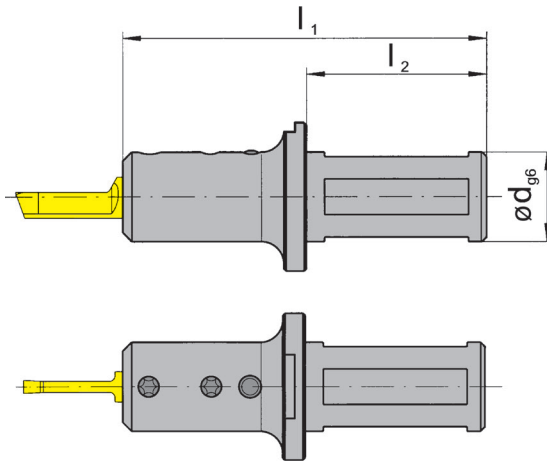

Internal Coolant

Part number	d	l ₁	l ₂	D _{min}
SBU110.0750.1.02.IK	.750	3.465	1.969	.354
SBU110.1000.1.02.IK	1.000	3.465	1.969	.354
SBU110.1250.1.02.IK	1.250	3.465	1.969	.354

Further sizes upon request

Dimensions in inch

Clamping length of inserts = 1.024"

For torque specification of the screw, please see Technical Instructions.



Spare Parts

Toolholder	Clamping Screw	TORX PLUS® Wrench
SBU110...	6.075T15P	T15PQ

Toolholder

SB110

Bore Ø from 9 mm

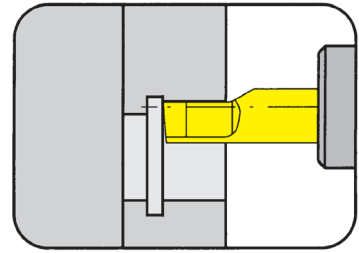

for Insert

Type N110
NU110

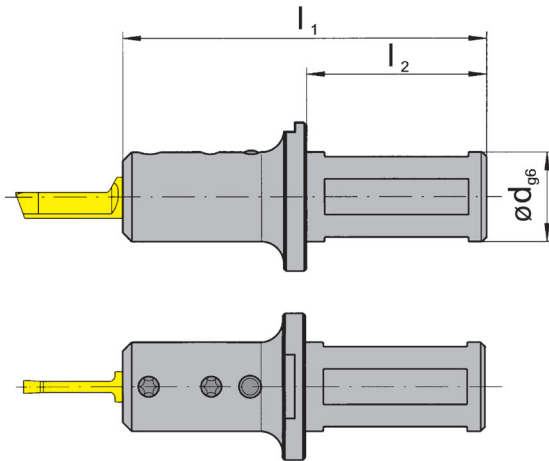

Internal Coolant

Part number	d	l ₁	l ₂	D _{min}
SB110.0020.1.02.IK	20	88	50	9
SB110.0025.1.02.IK	25	88	50	9
SB110.0032.1.02.IK	32	88	50	9

Further sizes upon request

Dimensions in mm

Clamping length of inserts = 26 mm!

For torque specification of the screw, please see Technical Instructions.

Spare Parts

Toolholder	Clamping Screw	TORX PLUS® Wrench
SB110...	6.075T15P	T15PQ



Insert

NU105/NU110

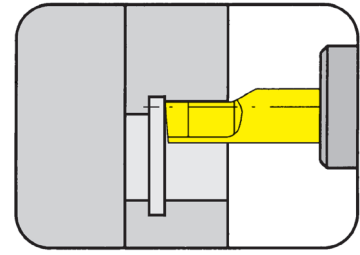

Bore Ø from .256"

for Toolholder

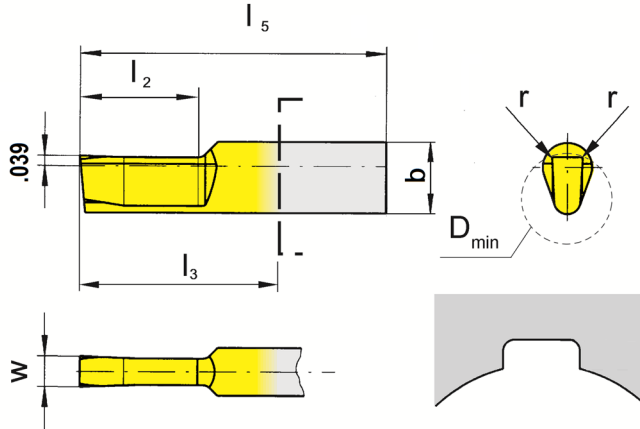

- Type
- SB105
 - SBU105
 - SB110
 - SBU110
 - B105
 - BU105
 - B110
 - BU110

Keyways according to Inch Standards

Part number	w	b	l ₅	l ₂	l ₃	r	D _{min}		AN25	TA45
NU105.0625.04.01	.064	.276	1.181	.472	.709	.004	.256			▲
NU105.0937.04.01	.095	.276	1.181	.472	.709	.004	.256			▲
NU105.1250.04.01	.126	.276	1.378	.591	.906	.004	.256			▲
NU105.1562.04.01	.157	.276	1.378	.591	.906	.004	.256			▲
NU110.1562.08.04	.157	-	2.362	.984	1.339	.008	.354			▲
NU110.1562.08.07	.157	-	2.953	1.575	1.929	.008	.354			▲
NU110.1875.08.04	.189	-	2.362	.984	1.339	.008	.354			▲
NU110.1875.08.07	.189	-	2.953	1.575	1.929	.008	.354			▲
								P	•	•
								M	o	•
								K	-	•
								N	-	•
								S	-	•
								H	-	-

▲ on stock Δ 4 weeks x upon request
 ● recommended
 o alternative recommendation
 - not suitable
 □ uncoated grades
 ■ coated grades
 ■ brazed/Cermet

Carbide grades

Dimensions in inch

Ordering note:

For Dimensions of Groove DIN please see Technical Instructions.



Insert

NU105/NU110

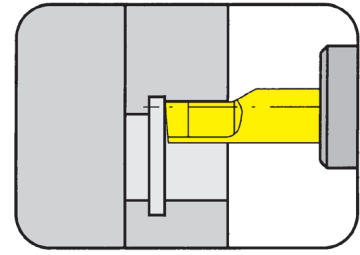

Bore Ø from .236"

Recommended for: Broaching units

for Toolholder

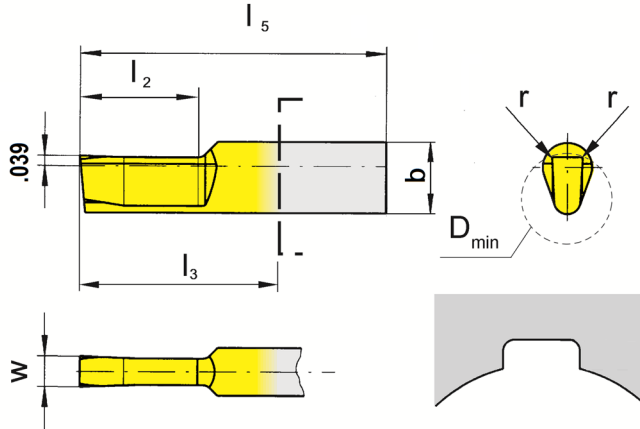

- Type
- SB105
 - SBU105
 - SB110
 - SBU110
 - B105
 - BU105
 - B110
 - BU110

Keyways according to Inch Standards

Part number	w	b	l ₅	l ₂	l ₃	r	D _{min}	AN25	TA45
NU105.0625.4.01.A2	.064	.276	1.181	.472	.709	.004	.236	▲	
NU105.0937.4.01.A2	.095	.276	1.181	.472	.709	.004	.236	▲	
NU105.1250.4.01.A2	.126	.276	1.378	.591	.906	.004	.256	▲	
NU105.1562.4.01.A2	.157	.276	1.378	.591	.906	.004	.256	▲	
NU110.1562.8.04.A2	.157	-	2.362	.984	1.339	.008	.354	▲	
NU110.1562.8.07.A2	.157	-	2.953	1.575	1.929	.008	.354	▲	
NU110.1875.8.04.A2	.189	-	2.362	.984	1.339	.008	.354	▲	
NU110.1875.8.07.A2	.189	-	2.953	1.575	1.929	.008	.354	▲	

- ▲ on stock Δ 4 weeks x upon request
- recommended
- alternative recommendation
- not suitable
- uncoated grades
- coated grades
- brazed/Cermet

Dimensions in inch

Ordering note:

For Dimensions of Groove DIN please see Technical Instructions.

	P	M	K	N	S	H
AN25	●	○	-	-	-	-
TA45	●	●	●	●	●	-

Carbide grades



Insert

NU105/NU110

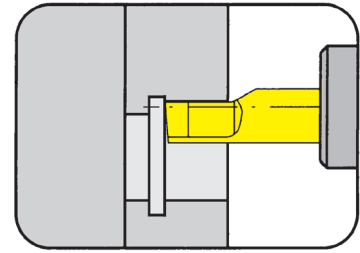

Bore Ø from .236"

Recommended for: conventional broaching

for Toolholder

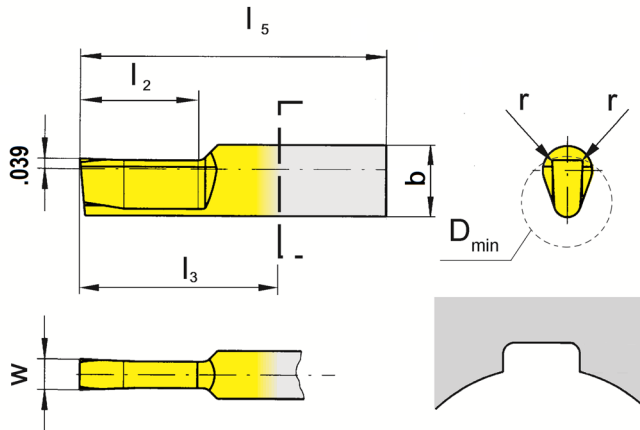

- Type
- SB105
 - SBU105
 - SB110
 - SBU110
 - B105
 - BU105
 - B110
 - BU110

Keyways according to
Inch Standards

Part number	w	b	l ₅	l ₂	l ₃	r	D _{min}	AN25	TA45
NU105.0625.4.01.B1	.064	.276	1.181	.472	.709	.004	.236	▲	
NU105.0937.4.01.B1	.095	.276	1.181	.472	.709	.004	.236	▲	
NU105.1250.4.01.B1	.126	.276	1.378	.591	.906	.004	.256	▲	
NU105.1562.4.01.B1	.157	.276	1.378	.591	.906	.004	.256	▲	
NU110.1562.8.04.B1	.157	-	2.362	.984	1.339	.008	.354	▲	
NU110.1562.8.07.B1	.157	-	2.953	1.575	1.929	.008	.354	▲	
NU110.1875.8.04.B1	.189	-	2.362	.984	1.339	.008	.354	▲	
NU110.1875.8.07.B1	.189	-	2.953	1.575	1.929	.008	.354	▲	

- ▲ on stock Δ 4 weeks x upon request
- recommended
- alternative recommendation
- not suitable
- uncoated grades
- coated grades
- brazed/Cermet

Dimensions in inch

	P	M	K	N	S	H
AN25	●	○	-	-	-	-
TA45	●	●	●	●	●	-

Carbide grades

Ordering note:

For Dimensions of Groove DIN please see Technical Instructions.

X

Insert

N105/N110

Tolerance grade C11

Bore Ø from .236"

Recommended for: Broaching units

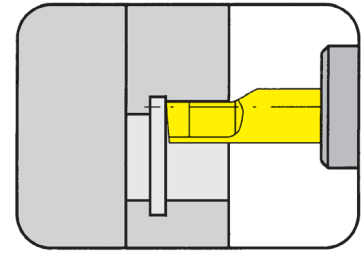

for Toolholder

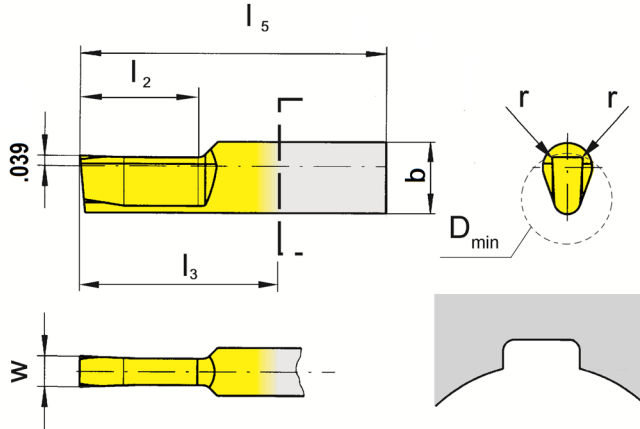

- Type
- SB105
 - SBU105
 - SB110
 - SBU110
 - B105
 - BU105
 - B110
 - BU110

Keyways according to DIN138

Part number	w	b	l ₅	l ₂	l ₃	r	D _{min}	AN25
N105.0210.2.08.A2	.083	.276	1.181	.472	.709	.014	.236	▲
N105.0310.2.10.A2	.122	.276	1.181	.472	.709	.014	.256	▲
N105.0310.2.13.A2	.122	.276	1.181	.472	.709	.020	.256	▲
N105.0410.2.16.A2	.163	.276	1.181	.472	.709	.020	.256	▲
N110.0410.05.04.A2	.163	-	2.362	.984	1.339	.020	.354	▲
N110.0410.05.07.A2	.163	-	2.953	1.575	1.929	.020	.354	▲
N110.0510.05.04.A2	.202	-	2.362	.984	1.339	.020	.354	▲
N110.0510.05.07.A2	.202	-	2.953	1.575	1.929	.020	.354	▲

▲ on stock Δ 4 weeks x upon request

- recommended
- o alternative recommendation
- not suitable

- uncoated grades
- coated grades
- brazed/Cermet

Dimensions in inch

P	•
M	o
K	-
N	-
S	-
H	-

Carbide grades

Ordering note:

For Dimensions of Groove DIN please see Technical Instructions.

Insert

N105/N110

Tolerance grade D10

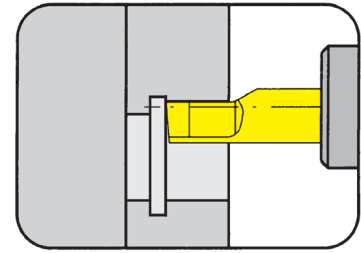

Bore Ø from .236"

Recommended for: Broaching units

for Toolholder

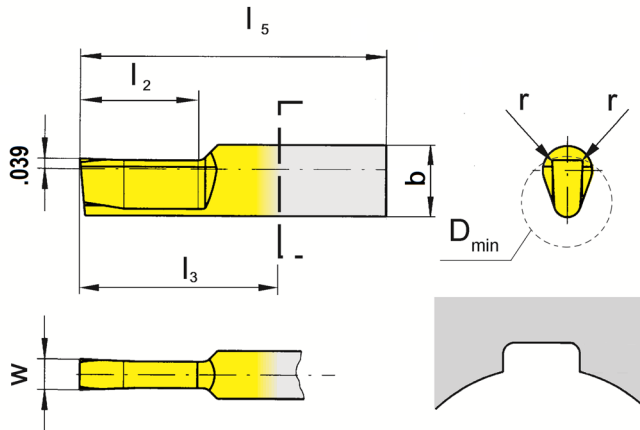

- Type
- SB105
 - SBU105
 - SB110
 - SBU110
 - B105
 - BU105
 - B110
 - BU110

Part number	w	b	l ₅	l ₂	l ₃	r	D _{min}	AN25
N105.0205.01.01.A2	.081	.276	1.181	.472	.709	.005	.236	x
N105.0305.01.01.A2	.120	.276	1.181	.472	.709	.005	.256	x
N105.0407.01.01.A2	.160	.276	1.378	.591	.906	.005	.256	x
N110.0407.02.04.A2	.160	-	2.362	.984	1.339	.008	.354	x
N110.0407.02.07.A2	.160	-	2.362	1.575	1.339	.008	.354	x
N110.0507.02.04.A2	.200	-	2.362	.984	1.339	.008	.354	x
N110.0507.02.07.A2	.200	-	2.362	1.575	1.339	.008	.354	x

▲ on stock Δ 4 weeks x upon request

- recommended
- alternative recommendation
- not suitable

- uncoated grades
- coated grades
- brazed/Cermet

Dimensions in inch

P	•
M	○
K	-
N	-
S	-
H	-

Carbide grades

Ordering note:

For Dimensions of Groove DIN please see Technical Instructions.

X

Insert

N105/N110

Tolerance grade H9

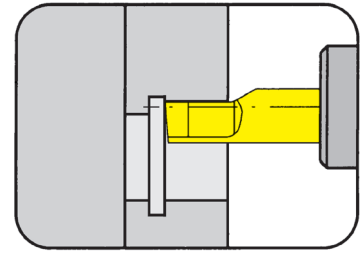

Bore Ø from .236"

Recommended for: Broaching units

for Toolholder

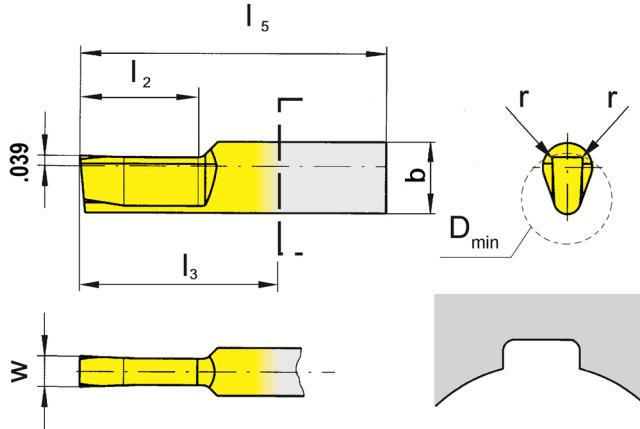

- Type
- SB105
 - SBU105
 - SB110
 - SBU110
 - B105
 - BU105
 - B110
 - BU110

Part number	w	b	l ₅	l ₂	l ₃	r	D _{min}	AN25
N105.0202.01.01.A2	.080	.276	1.181	.472	.709	.004	.236	▲
N105.0302.01.01.A2	.119	.276	1.181	.472	.709	.004	.256	▲
N105.0402.01.01.A2	.158	.276	1.378	.591	.906	.004	.256	▲
N110.0402.02.04.A2	.158	-	2.362	.984	1.339	.008	.354	▲
N110.0402.02.07.A2	.158	-	2.953	1.575	1.929	.008	.354	▲
N110.0502.02.04.A2	.198	-	2.362	.984	1.339	.008	.354	▲
N110.0502.02.07.A2	.198	-	2.953	1.575	1.929	.008	.354	▲

- ▲ on stock Δ 4 weeks x upon request
- recommended
- alternative recommendation
- not suitable
- uncoated grades
- coated grades
- brazed/Cermet

Dimensions in inch

P	•
M	○
K	-
N	-
S	-
H	-

Carbide grades

Ordering note:

For Dimensions of Groove DIN please see Technical Instructions.



Insert

N105/N110

Tolerance grade P9

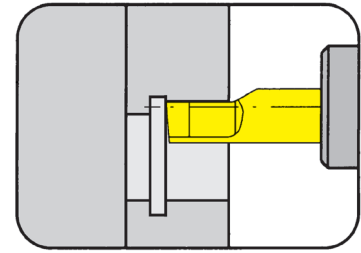

Bore Ø from .236"

Recommended for: Broaching units

for Toolholder

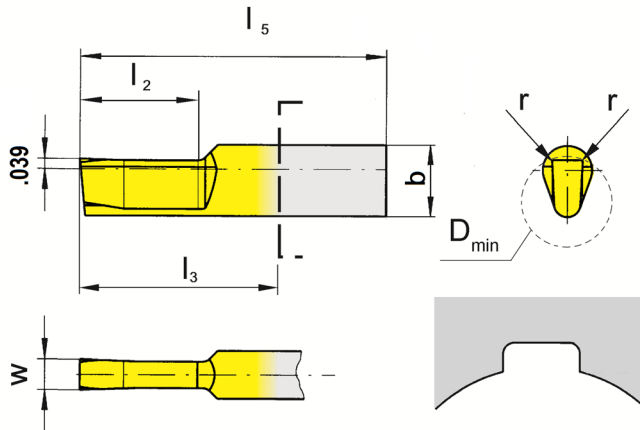

- Type
- SB105
 - SBU105
 - SB110
 - SBU110
 - B105
 - BU105
 - B110
 - BU110

Keyways according to DIN6885

Part number	w	b	l_5	l_2	l_3	r	D_{min}	AN25
N105.0198.01.01.A2	.078	.276	1.181	.472	.709	.004	.236	▲
N105.0298.01.01.A2	.117	.276	1.181	.472	.709	.004	.256	▲
N105.0397.01.01.A2	.156	.276	1.378	.591	.906	.004	.256	▲
N110.0397.02.04.A2	.157	-	2.362	.984	1.339	.008	.354	▲
N110.0397.02.07.A2	.157	-	2.953	1.575	1.929	.008	.354	▲
N110.0497.02.04.A2	.196	-	2.362	.984	1.339	.008	.354	▲
N110.0497.02.07.A2	.196	-	2.953	1.575	1.929	.008	.354	▲

▲ on stock Δ 4 weeks x upon request

- recommended
- o alternative recommendation
- not suitable

- uncoated grades
- coated grades
- brazed/Cermet

Dimensions in inch

P	•
M	o
K	-
N	-
S	-
H	-

Carbide grades

Ordering note:

For Dimensions of Groove DIN please see Technical Instructions.

X

Insert

N105/N110

Tolerance grade JS9

Bore Ø from .236"

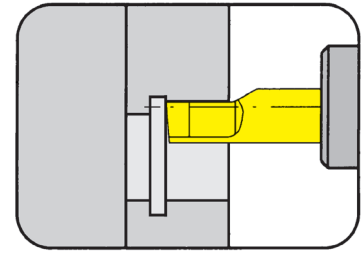

Recommended for: Broaching units

for Toolholder

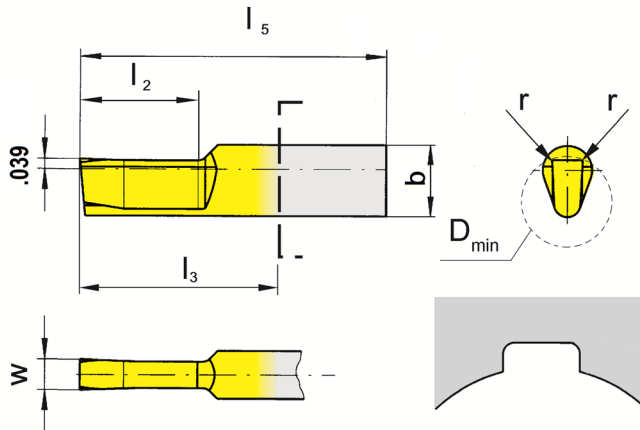

- Type
- SB105
 - SBU105
 - SB110
 - SBU110
 - B105
 - BU105
 - B110
 - BU110

Keyways according to DIN6885

Part number	w	b	l ₅	l ₂	l ₃	r	D _{min}	AN25
N105.0200.01.01.A2	.079	.276	1.181	.472	.709	.004	.236	▲
N105.0300.01.01.A2	.118	.276	1.181	.472	.709	.004	.256	▲
N105.0400.01.01.A2	.157	.276	1.378	.591	.906	.004	.256	▲
N105.0400.02.01.A2	.157	.276	1.378	.591	.906	.008	.256	▲
N110.0400.02.04.A2	.157	-	2.362	.984	1.339	.008	.354	▲
N110.0400.02.07.A2	.157	-	2.953	1.575	1.929	.008	.354	▲
N110.0500.02.04.A2	.197	-	2.362	.984	1.339	.008	.354	▲
N110.0500.02.07.A2	.197	-	2.953	1.575	1.929	.008	.354	▲

▲ on stock Δ 4 weeks x upon request

- recommended
- o alternative recommendation
- not suitable

- uncoated grades
- coated grades
- brazed/Cermet

Dimensions in inch

P	•
M	o
K	-
N	-
S	-
H	-

Carbide grades

Ordering note:

For Dimensions of Groove DIN please see Technical Instructions.

Insert

N105/N110

Bore Ø from .236"

Recommended for: Broaching units

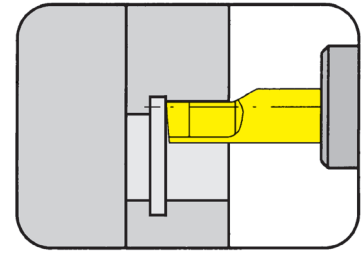

for Toolholder

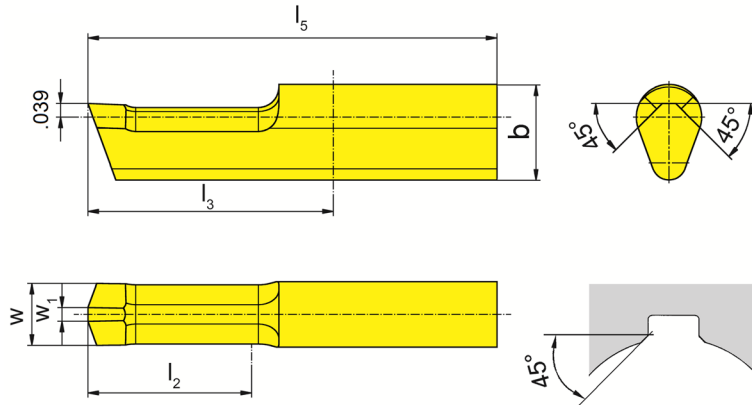

- Type
- SB105
 - SBU105
 - SB110
 - SBU110
 - B105
 - BU105
 - B110
 - BU110

Chamfering

Part number	w	B	w ₁	I ₅	I ₂	I ₃	D _{min}	AN25
N105.4545.2.6.A1	.177	.276	.039	1.181	.472	.709	.236	▲
N105.4545.3.6.A1	.177	.276	.039	1.378	.787	.906	.236	▲
N110.4545.4.9.A1	.248	-	.079	2.362	.984	1.339	.354	▲
N110.4545.7.9.A1	.248	-	.079	2.953	1.575	1.929	.354	▲

▲ on stock Δ 4 weeks x upon request

- recommended
- alternative recommendation
- not suitable

- uncoated grades
- coated grades
- brazed/Cermet

Dimensions in inch

P	●
M	○
K	-
N	-
S	-
H	-

Carbide grades

Insert

N105/N110

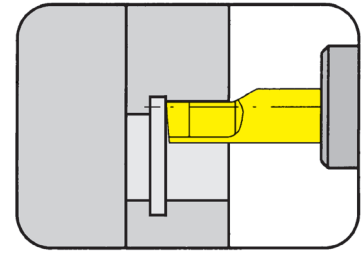

Hexagon socket from

SW .079"

Recommended for: Broaching units

for Toolholder

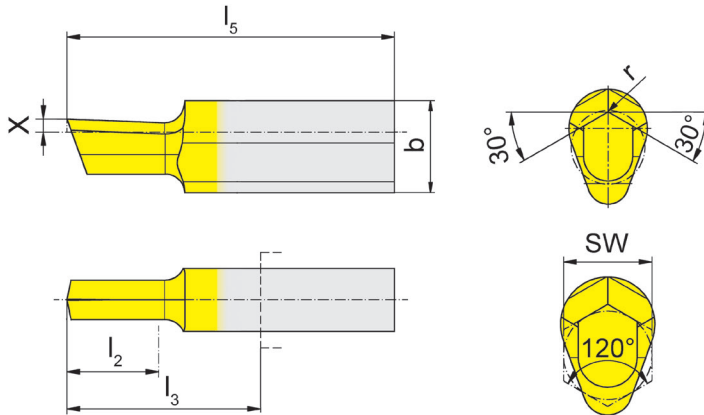

Type SB105
SBU105
SB110
SBU110
B105
BU105
B110
BU110

Hexagon socket

Part number	b	l ₅	l ₂	l ₃	r	SW	Pilot Ø	X	AN25
N105.SW20.20.01.A1	.276	.984	.157	.512	.002	.079 - .098	SW	.039	▲
N105.SW25.25.01.A1	.276	.984	.157	.512	.002	.098 - .114	SW	.039	▲
N105.SW30.30.01.A1	.276	.984	.177	.512	.002	.114 - .138	SW	.039	▲
N105.SW35.35.01.A1	.276	.984	.217	.512	.002	.138 - .157	SW	.039	▲
N105.SW40.40.01.A1	.276	.984	.236	.512	.004	.157 - .177	SW	.039	▲
N105.SW45.45.01.A1	.276	.984	.276	.512	.004	.177 - .196	SW	.039	▲
N105.SW56.56.01.A1	.276	.984	.354	.512	.004	.196 - .315	SW	.039	▲
N105.SW80.80.01.A1	.276	1.181	.472	.709	.004	.315 - .394	SW+.004	.039	▲
N110.SW14.14.03.A1	-	2.165	.787	1.142	.008	.394 - .551	SW+.004	.059	▲
N110.SW16.16.04.A1	-	2.165	.984	1.142	.008	.551 - .650 .661 - .709	SW+.004 SW+.008	.079	▲

▲ on stock Δ 4 weeks x upon request

● recommended

○ alternative recommendation

- not suitable

■ uncoated grades

■ coated grades

■ brazed/Cermet

Dimensions in inch

P	●
M	○
K	-
N	-
S	-
H	-

Carbide grades

X

Insert

N105



Recommended for: Broaching units

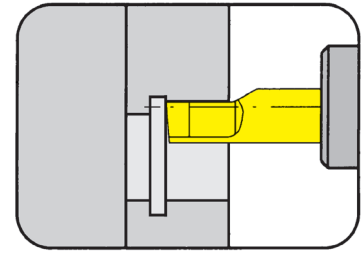

for Toolholder

Type SB105
SBU105
B105
BU105

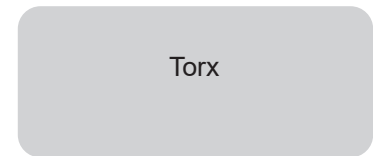
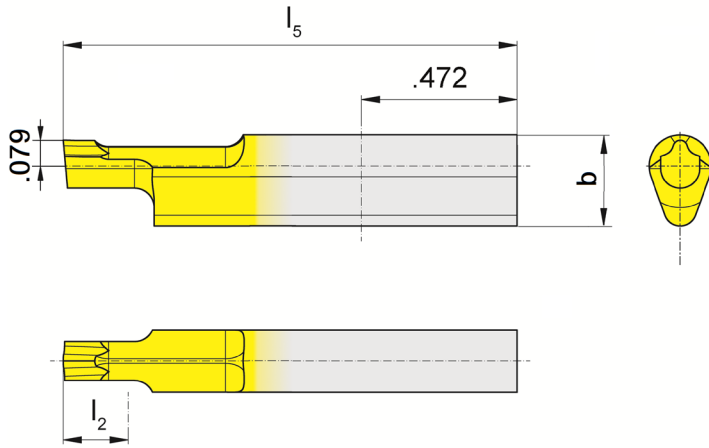

Part number	Torx	b	l_5	l_2	Pilot Ø	AN25
N105.TX15.24.03.A1	T15	.276	1.378	.157	.095	▲
N105.TX20.28.03.A1	T20	.276	1.378	.157	.112	▲
N105.TX25.32.03.A1	T25	.276	1.378	.197	.128	▲
N105.TX30.40.03.A1	T30	.276	1.378	.197	.159	▲

▲ on stock Δ 4 weeks x upon request

● recommended
○ alternative recommendation
- not suitable

□ uncoated grades
■ coated grades
■ brazed/Cermet

Dimensions in inch

P	●
M	○
K	-
N	-
S	-
H	-

Carbide grades

Insert

N105/N110

Tolerance grade C11

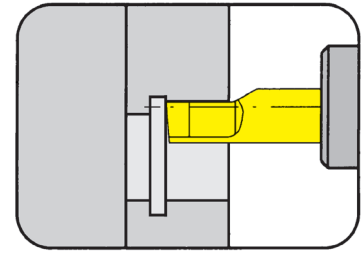

Bore Ø from .236"

Recommended for: conventional broaching

for Toolholder

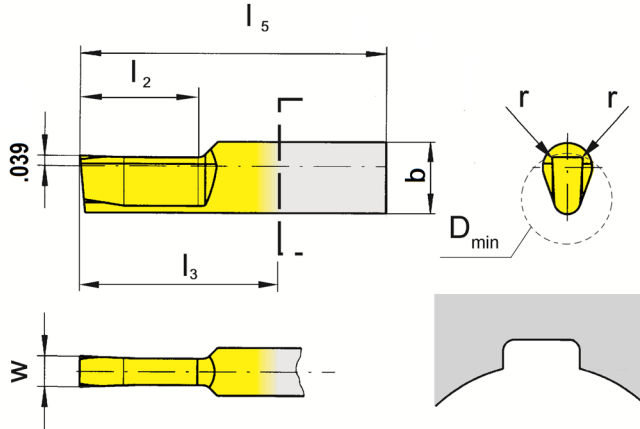

- Type
- SB105
 - SBU105
 - SB110
 - SBU110
 - B105
 - BU105
 - B110
 - BU110

Keyways according to DIN138

Part number	w	b	l ₅	l ₂	l ₃	r	D _{min}	AN25
N105.0210.2.08.B1	.083	.276	1.181	.472	.709	.014	.236	▲
N105.0310.2.10.B1	.122	.276	1.181	.472	.709	.014	.256	▲
N105.0310.2.13.B1	.122	.276	1.181	.472	.709	.020	.256	▲
N105.0410.2.16.B1	.163	.276	1.181	.472	.709	.020	.256	▲
N110.0410.05.04.B1	.163	-	2.362	.984	1.339	.020	.354	▲
N110.0410.05.07.B1	.163	-	2.953	1.575	1.929	.020	.354	▲
N110.0510.05.04.B1	.202	-	2.362	.984	1.339	.020	.354	▲
N110.0510.05.07.B1	.202	-	2.953	1.575	1.929	.020	.354	▲

▲ on stock Δ 4 weeks x upon request

- recommended
- alternative recommendation
- not suitable

- uncoated grades
- coated grades
- brazed/Cermet

Dimensions in inch

P	•
M	○
K	-
N	-
S	-
H	-

Carbide grades

Ordering note:

For Dimensions of Groove DIN please see Technical Instructions.

Insert

N105/N110

Tolerance grade D10

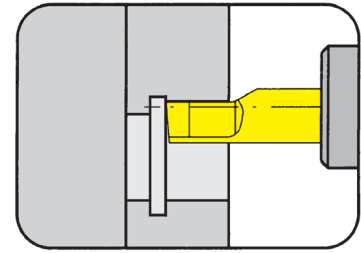

Bore Ø from .236"

Recommended for: conventional broaching

for Toolholder

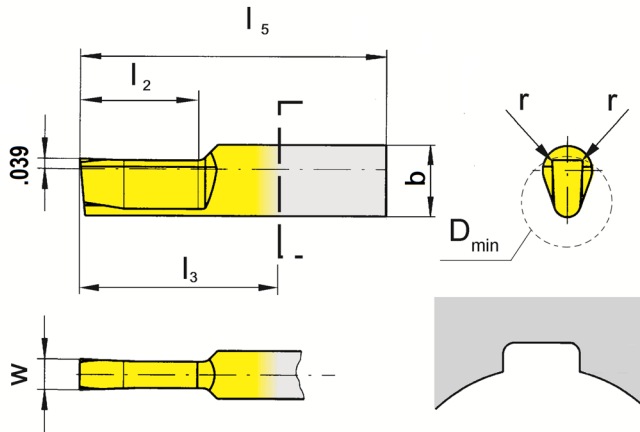

- Type
- SB105
 - SBU105
 - SB110
 - SBU110
 - B105
 - BU105
 - B110
 - BU110

Part number	w	b	l ₅	l ₂	l ₃	r	D _{min}	AN25
N105.0205.01.01.B1	.081	.276	1.181	.472	.709	.005	.236	x
N105.0305.01.01.B1	.120	.276	1.181	.472	.709	.005	.256	x
N105.0407.01.01.B1	.160	.276	1.378	.591	.906	.005	.256	x
N110.0407.02.04.B1	.160	-	2.362	.984	1.339	.008	.354	x
N110.0407.02.07.B1	.160	-	2.362	1.575	1.339	.008	.354	▲
N110.0507.02.04.B1	.200	-	2.362	.984	1.339	.008	.354	x
N110.0507.02.07.B1	.200	-	2.362	1.575	1.339	.008	.354	x

▲ on stock Δ 4 weeks x upon request

● recommended

○ alternative recommendation

- not suitable

□ uncoated grades

■ coated grades

■ brazed/Cermet

P	●
M	○
K	-
N	-
S	-
H	-

Dimensions in inch

Carbide grades

Ordering note:

For Dimensions of Groove DIN please see Technical Instructions.

X

Insert

N105/N110

Tolerance grade H9

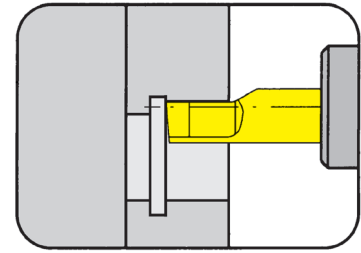

Bore Ø from .236"

Recommended for: conventional broaching

for Toolholder

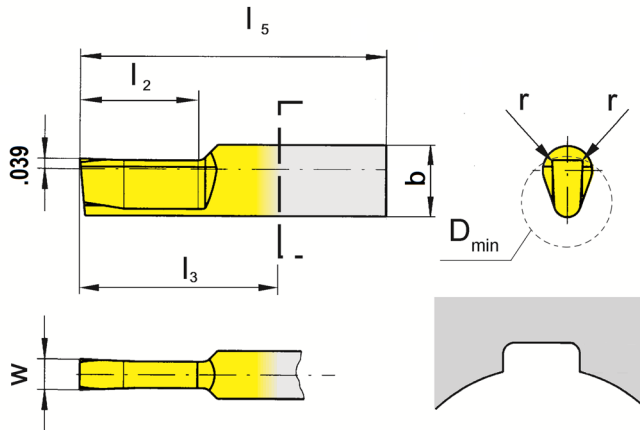

- Type
- SB105
 - SBU105
 - SB110
 - SBU110
 - B105
 - BU105
 - B110
 - BU110

Part number	w	b	l_5	l_2	l_3	r	D_{min}	AN25
N105.0202.01.01.B1	.080	.276	1.181	.472	.709	.004	.236	▲
N105.0302.01.01.B1	.119	.276	1.181	.472	.709	.004	.256	▲
N105.0402.01.01.B1	.158	.276	1.378	.591	.906	.004	.256	▲
N110.0402.02.04.B1	.158	-	2.362	.984	1.339	.008	.354	▲
N110.0402.02.07.B1	.158	-	2.953	1.575	1.929	.008	.354	▲
N110.0502.02.04.B1	.198	-	2.362	.984	1.339	.008	.354	▲
N110.0502.02.07.B1	.198	-	2.953	1.575	1.929	.008	.354	▲

▲ on stock Δ 4 weeks x upon request

● recommended

o alternative recommendation

- not suitable

□ uncoated grades

■ coated grades

■ brazed/Cermet

Dimensions in inch

P	•
M	o
K	-
N	-
S	-
H	-

Carbide grades

Ordering note:

For Dimensions of Groove DIN please see Technical Instructions.

Insert

N105/N110

Tolerance grade P9

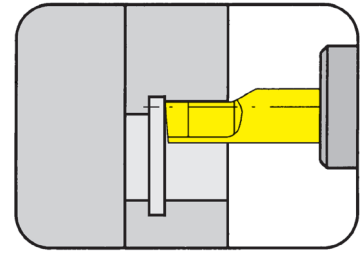

Bore Ø from .236"

Recommended for: conventional broaching

for Toolholder

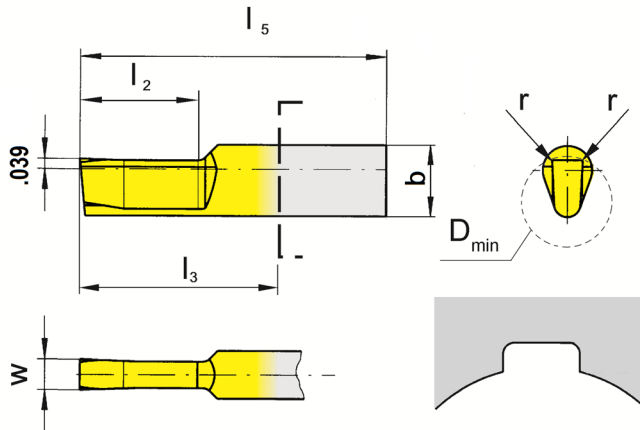

- Type
- SB105
 - SBU105
 - SB110
 - SBU110
 - B105
 - BU105
 - B110
 - BU110

Keyways according to DIN6885

Part number	w	b	l ₅	l ₂	l ₃	r	D _{min}	AN25
N105.0198.01.01.B1	.078	.276	1.181	.472	.709	.004	.236	▲
N105.0298.01.01.B1	.117	.276	1.181	.472	.709	.004	.256	▲
N105.0397.01.01.B1	.156	.276	1.378	.591	.906	.004	.256	▲
N110.0397.02.04.B1	.157	-	2.362	.984	1.339	.008	.354	▲
N110.0397.02.07.B1	.157	-	2.953	1.575	1.929	.008	.354	▲
N110.0497.02.04.B1	.196	-	2.362	.984	1.339	.008	.354	▲
N110.0497.02.07.B1	.196	-	2.953	1.575	1.929	.008	.354	▲

▲ on stock Δ 4 weeks x upon request

- recommended
- alternative recommendation
- not suitable

- uncoated grades
- coated grades
- brazed/Cermet

Dimensions in inch

P	•
M	○
K	-
N	-
S	-
H	-

Carbide grades

Ordering note:

For Dimensions of Groove DIN please see Technical Instructions.

X

Insert

N105/N110

Tolerance grade JS9

Bore Ø from .236"

Recommended for: conventional broaching

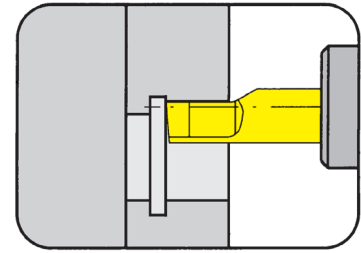

for Toolholder

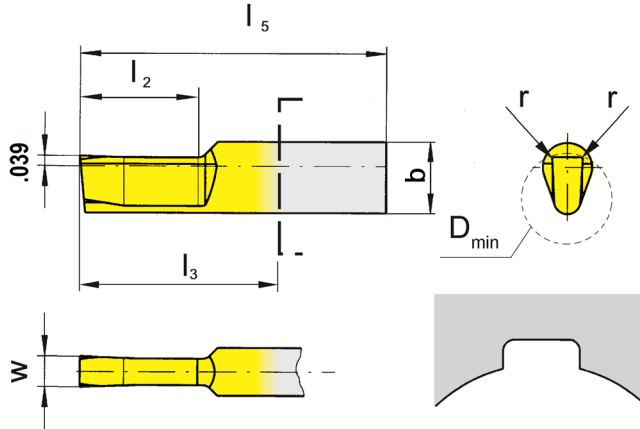

- Type
- SB105
 - SBU105
 - SB110
 - SBU110
 - B105
 - BU105
 - B110
 - BU110

Keyways according to DIN6885

Part number	w	b	l ₅	l ₂	l ₃	r	D _{min}	AN25
N105.0200.01.01.B1	.078	.276	1.118	.472	.709	.004	.236	▲
N105.0300.01.01.B1	.118	.276	1.118	.472	.709	.004	.256	▲
N105.0400.01.01.B1	.157	.276	1.378	.591	.906	.004	.256	▲
N105.0400.02.01.B1	.157	.276	1.378	.591	.906	.008	.256	▲
N110.0400.02.04.B1	.157	-	2.362	.984	1.339	.008	.354	▲
N110.0400.02.07.B1	.157	-	2.953	1.574	1.929	.008	.354	▲
N110.0500.02.04.B1	.197	-	2.362	.984	1.339	.008	.354	▲
N110.0500.02.07.B1	.197	-	2.953	1.574	1.929	.008	.354	▲

▲ on stock Δ 4 weeks x upon request

- recommended
- o alternative recommendation
- not suitable

- uncoated grades
- coated grades
- brazed/Cermet

Dimensions in inch

P	•
M	o
K	-
N	-
S	-
H	-

Carbide grades

Ordering note:

For Dimensions of Groove DIN please see Technical Instructions.

Insert

N105/N110

Bore Ø from .236"

Recommended for: conventional broaching

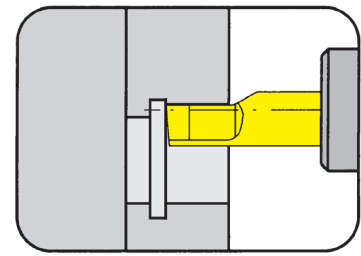

for Toolholder

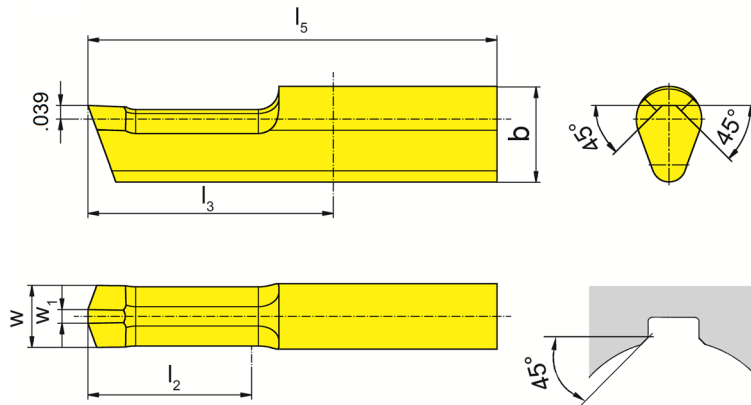

- Type
- SB105
 - SBU105
 - SB110
 - SBU110
 - B105
 - BU105
 - B110
 - BU110

Chamfering

Part number	w	b	w ₁	l ₅	l ₂	l ₃	D _{min}		AN25
N105.4545.2.6.B1	.177	.276	.039	1.181	.472	.709	.236		▲
N105.4545.3.6.B1	.177	.276	.039	1.378	.787	.906	.236		▲
N110.4545.4.9.B1	.248	-	.079	2.362	.984	1.339	.354		▲
N110.4545.7.9.B1	.248	-	.079	2.953	1.575	1.929	.354		▲

▲ on stock Δ 4 weeks x upon request

- recommended
- alternative recommendation
- not suitable

- uncoated grades
- coated grades
- brazed/Cermet

Dimensions in inch

P	●
M	○
K	-
N	-
S	-
H	-

Carbide grades

Insert

N105/N110

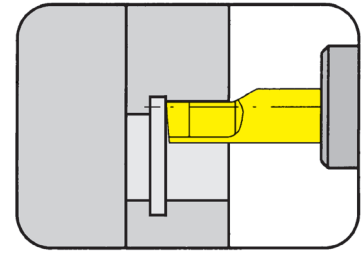

Hexagon socket from

SW .079"

Recommended for: conventional broaching

for Toolholder

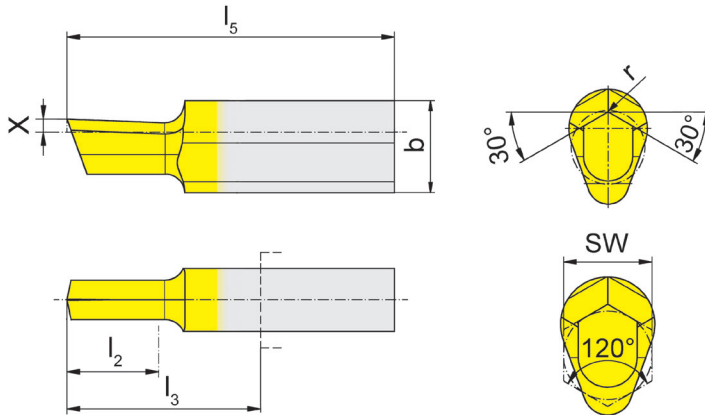

Type SB105
SBU105
SB110
SBU110
B105
BU105
B110
BU110

Hexagon socket

Part number	l_5	b	l_2	l_3	r	SW	Pilot Ø	X	AN25
N105.SW20.20.01.B1	.984	.276	.157	.512	.002	.078 - .098	SW	.039	▲
N105.SW25.25.01.B1	.984	.276	.157	.512	.002	.098 - .114	SW	.039	▲
N105.SW30.30.01.B1	.984	.276	.177	.512	.002	.114 - .138	SW	.039	▲
N105.SW35.35.01.B1	.984	.276	.217	.512	.002	.138 - .157	SW	.039	▲
N105.SW40.40.01.B1	.984	.276	.236	.512	.004	.157 - .177	SW	.039	▲
N105.SW45.45.01.B1	.984	.276	.276	.512	.004	.177 - .197	SW	.039	▲
N105.SW56.56.01.B1	.984	.276	.354	.512	.004	.197 - .315	SW	.039	▲
N105.SW80.80.01.B1	1.181	.276	.472	.709	.004	.315 - .394	SW + .004	.039	▲
N110.SW14.14.03.B1	2.165	-	.787	1.142	.008	.394 - .551	SW + .004	.059	▲
N110.SW16.16.04.B1	2.165	-	.984	1.142	.008	.551 - .650 .661 - .709	SW + .004 SW + .008	.079	▲

▲ on stock Δ 4 weeks x upon request

● recommended

○ alternative recommendation

- not suitable

■ uncoated grades

■ coated grades

■ brazed/Cermet

Dimensions in inch

P	•
M	○
K	-
N	-
S	-
H	-

Carbide grades

X

Insert

N105/N110

Square Broaching from .SW 4

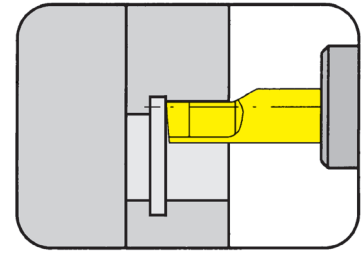

Recommended for: broaching units

for Toolholder

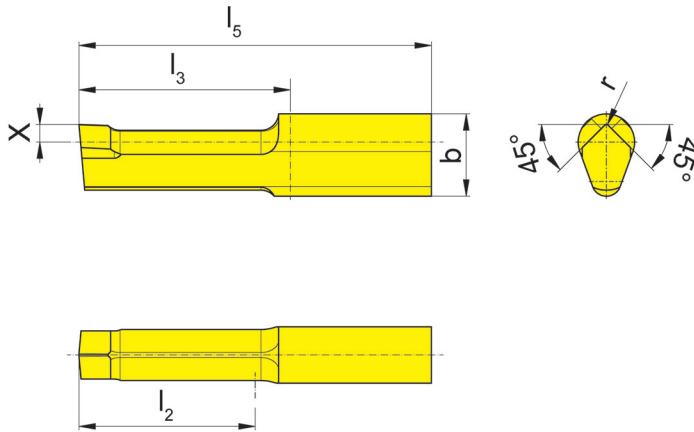

- Type
- SB105
 - SBU105
 - SB110
 - SBU110
 - B105
 - BU105
 - B110
 - BU110

Square Broaching

Part number	SW	b	l ₅	l ₂	l ₃	r	X	D _{min}	AN25
N105.SQ.0405.1.A1	.157 - .197	.276	.984	.394	.512	.008	.059	.161	▲
N105.SQ.0506.1.A1	.197 - .236	.276	1.181	.472	.709	.008	.059	.201	▲
N105.SQ.0608.2.A1	.236 - .315	.276	1.181	.591	.709	.008	.059	.240	▲
N110.SQ.0810.2.A1	.315 - .394	.406	1.772	.591	.748	.008	.098	.319	▲
N110.SQ.1013.2.A1	.394 - .512	.406	1.772	.591	.748	.008	.098	.401	▲

▲ on stock Δ 4 weeks x upon request

- recommended
- alternative recommendation
- not suitable

- uncoated grades
- coated grades
- brazed/Cermet

Dimensions in inch

P	●
M	○
K	-
N	-
S	-
H	-

Carbide grades

Insert

N105/N110

Square Broaching from SW 4

Recommended for: conventional broaching

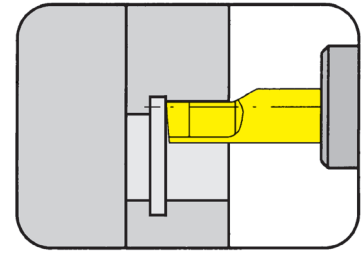

for Toolholder

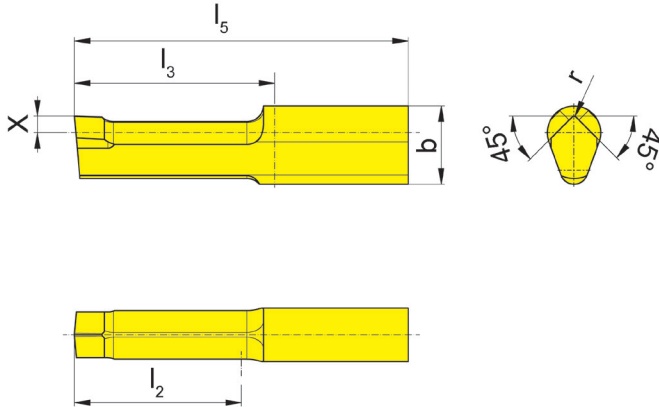

- Type
- SB105
 - SBU105
 - SB110
 - SBU110
 - B105
 - BU105
 - B110
 - BU110

Square Broaching

Part number	SW	b	l ₅	l ₂	l ₃	r	X	D _{min}	AN25
N105.SQ.0405.1.B1	.157 - .197	.276	.984	.394	.512	.008	.059	.161	▲
N105.SQ.0506.1.B1	.197 - .236	.276	1.181	.472	.709	.008	.059	.201	▲
N105.SQ.0608.2.B1	.236 - .315	.276	1.181	.591	.709	.008	.059	.240	▲
N110.SQ.0810.2.B1	.315 - .394	.406	1.772	.591	.748	.008	.098	.319	▲
N110.SQ.1013.2.B1	.394 - .512	.406	1.772	.591	.748	.008	.098	.401	▲

▲ on stock Δ 4 weeks x upon request

- recommended
- alternative recommendation
- not suitable

- uncoated grades
- coated grades
- brazed/Cermet

Dimensions in inch

Carbide grades	Symbol
P	●
M	○
K	-
N	-
S	-
H	-

Carbide grades



Insert

N105



Recommended for: conventional broaching

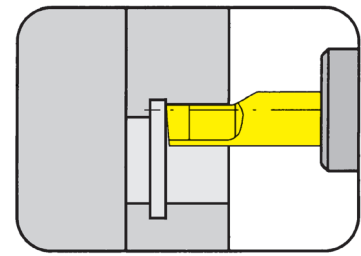

for Toolholder

Type SB105
SBU105
B105
BU105

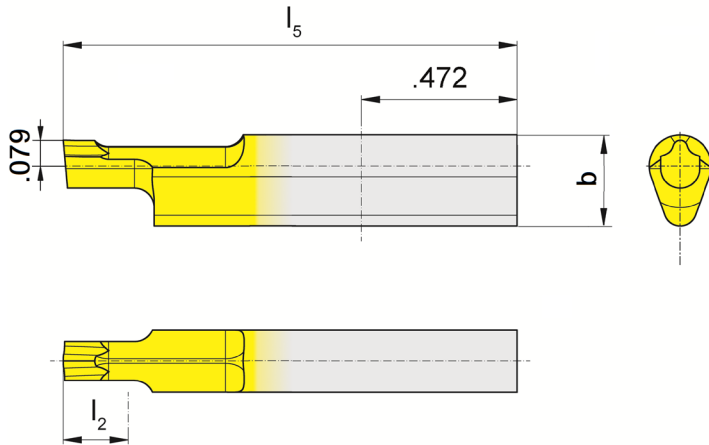

Part number	Torx	b	l_5	l_2	Pilot Ø	AN25
N105.TX15.24.03.B1	T15	.276	1.378	.157	.095	▲
N105.TX20.28.03.B1	T20	.276	1.378	.157	.112	▲
N105.TX25.32.03.B1	T25	.276	1.378	.197	.128	▲
N105.TX30.40.03.B1	T30	.276	1.378	.197	.159	▲

▲ on stock Δ 4 weeks x upon request

● recommended
○ alternative recommendation
- not suitable

□ uncoated grades
■ coated grades
■ brazed/Cermet

Dimensions in inch

P	●
M	○
K	-
N	-
S	-
H	-

Carbide grades



Toolholder
SH117/SHU117

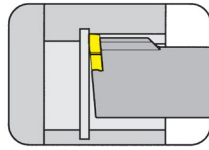

Page
X40-X58

Insert
SU117/S117

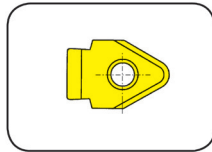

Page
X59-X77

Technical Instructions

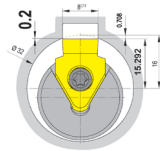

Page
X78-X84

117



Toolholder with Inserts

Bore Ø from . 551"

X

Toolholder

SHU117

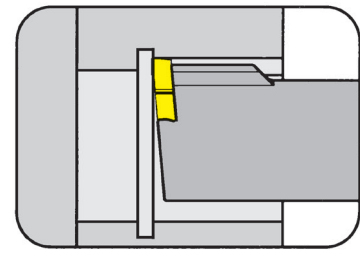

Bore Ø from .551"

for Insert

Type S117
SU117

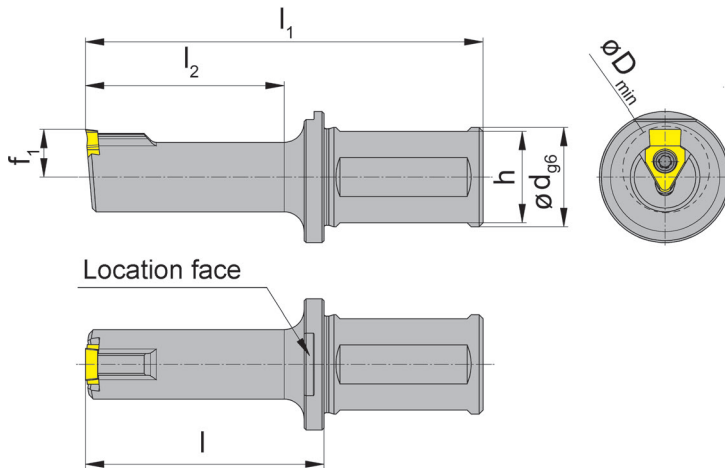

Part number	d	h	l	l ₁	l ₂	D _{min}	f ₁	Form
SHU117.0100.1.10	1.000	.921	2.087	4.055	1.575	.669	.374	A
SHU117.0100.2.10	1.000	.921	2.677	4.646	2.165	.669	.374	A
SHU117.0125.1.10	1.250	1.171	2.087	4.055	1.575	.669	.374	A
SHU117.0610.1.10	1.000	.921	2.008	3.976	1.575	.625	.425	A1
SHU117.0612.1.10	1.250	1.171	2.008	3.976	1.575	.625	.425	A1
SHU117.0910.1.10	1.000	.921	2.480	4.449	1.969	.866	.472	A
SHU117.0910.2.10	1.000	.921	3.268	5.236	2.756	.866	.472	A
SHU117.0912.1.10	1.250	1.171	2.480	4.449	1.969	.866	.472	A
SHU117.0912.2.10	1.250	1.171	3.268	5.236	2.756	.866	.472	A
SHU117.1000.1.10	1.000	.921	2.480	4.449	1.969	.866	.472	B
SHU117.1000.2.10	1.000	.921	3.268	5.236	2.756	.866	.472	B
SHU117.1250.1.10	1.250	1.171	2.480	4.449	1.969	.866	.472	B
SHU117.1250.2.10	1.250	1.171	3.268	5.236	2.756	.866	.472	B

Further sizes upon request

Dimensions in inch

For torque specification of the screw, please see Technical Instructions.

X

Spare Parts

Toolholder	Clamping Screw	TORX PLUS® Wrench
SHU117...10	4.09T15P	T15PQ

Broaching



Toolholder

SHU117

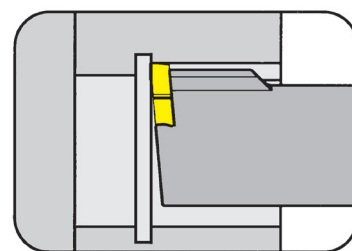

Bore Ø from .551"

for Insert

Type S117
SU117

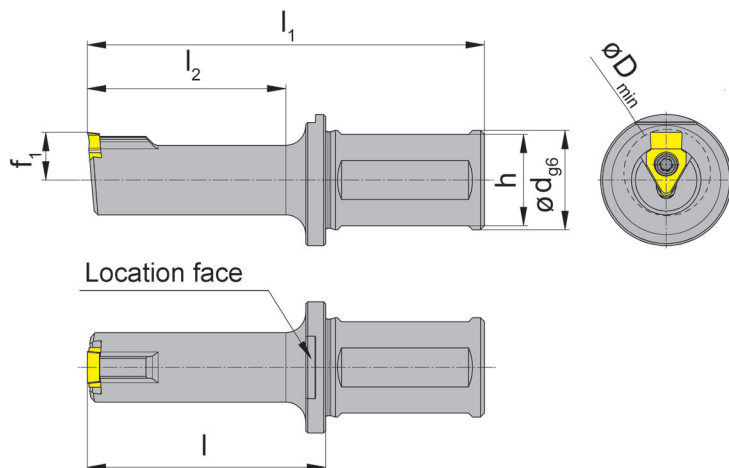

Part number	d	h	l	l ₁	l ₂	D _{min}	f ₁	Form
SHU117.0125.1.16	1.250	1.171	2.480	4.843	1.969	1.181	.659	C
SHU117.0125.2.16	1.250	1.171	3.465	5.827	2.953	1.181	.659	C
SHU117.0125.3.16	1.250	1.171	4.449	6.811	3.937	1.181	.659	C
SHU117.1250.1.16	1.250	1.171	2.480	4.843	1.969	1.496	.866	D
SHU117.1250.2.16	1.250	1.171	3.465	5.827	2.953	1.496	.866	D
SHU117.1250.3.16	1.250	1.171	4.449	6.811	3.937	1.496	.866	D
SHU117.1410.1.08	1.000	.921	1.654	3.622	1.181	.551	.378	F
SHU117.1410.1.3.08	1.000	.921	1.260	3.228	.787	.551	.378	G
SHU117.1410.2.08	1.000	.921	2.047	4.016	1.575	.551	.378	F
SHU117.1412.1.08	1.250	1.171	1.654	3.622	1.181	.551	.378	F
SHU117.1412.1.3.08	1.250	1.171	1.260	2.835	.787	.551	.378	G
SHU117.1412.2.08	1.250	1.171	2.047	4.016	1.575	.551	.378	F

Further sizes upon request

Dimensions in inch

For torque specification of the screw, please see Technical Instructions.

Spare Parts

Toolholder	Clamping Screw	TORX PLUS® Wrench
SHU117...16	5.12T20P	T20PQ
SHU117...08	030.3509.T15P	T15PQ



Toolholder

SH117

Bore Ø from

14 mm

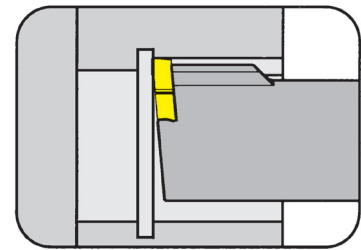

for Insert

Type S117
SU117

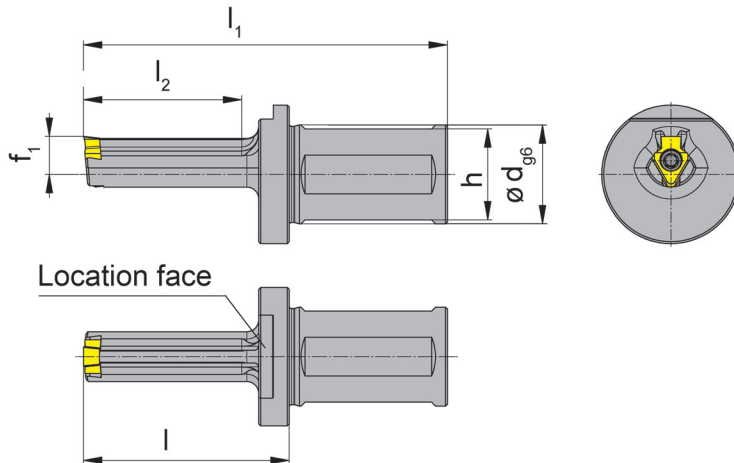

Part number	d	h	l	l ₁	l ₂	D _{min}	f ₁	Form
SH117.1425.1.3.08	25	23	32	82	20	14	9.6	G
SH117.1425.1.08	25	23	42	92	30	14	9.6	F
SH117.1425.2.08	25	23	52	102	40	14	9.6	F
SH117.1725.1.10	25	23	50	103	40	17	9.5	A
SH117.1725.2.10	25	23	65	118	55	17	9.5	A
SH117.0025.1.10	25	23	60	113	50	22	12.0	B
SH117.0025.2.10	25	23	80	133	70	22	12.0	B
SH117.3032.1.16	32	30	60	123	50	30	16.5	C
SH117.3032.2.16	32	30	85	148	75	30	16.5	C
SH117.3032.3.16	32	30	110	173	100	30	16.5	C
SH117.0032.1.16	32	30	60	123	50	38	22.0	D
SH117.0032.2.16	32	30	85	148	75	38	22.0	D
SH117.0032.3.16	32	30	110	173	100	38	22.0	D
SH117.4032.1.16	32	30	62	123	50	40	21.5	E
SH117.4032.2.16	32	30	87	148	75	40	21.5	E
SH117.4032.3.16	32	30	112	173	100	40	21.5	E

Further sizes upon request

Dimensions in mm

For torque specification of the screw, please see Technical Instructions.

Spare Parts

Toolholder	Clamping Screw	TORX PLUS® Wrench
SH117...08	030.3509.T15P	T15PQ
SH117...10	4.09T15P	T15PQ
SH117...16	5.12T20P	T20PQ

Toolholder

SHU117

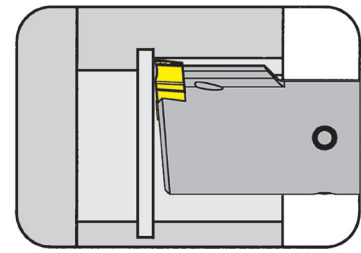

Bore Ø from .551"

for Insert

Type S117
SU117

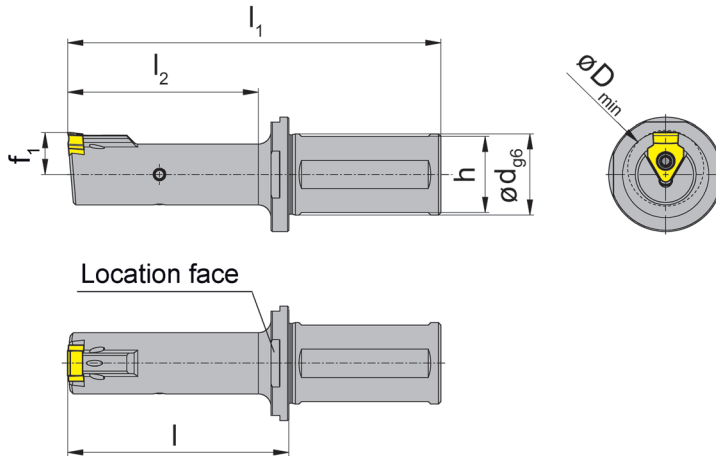

with through coolant supply

Part number	d	h	l	l ₁	l ₂	D _{min}	f ₁	Form
SHU117.0100.1.10.IK	1.00	.921	2.087	4.055	1.575	.669	.374	A
SHU117.0100.2.10.IK	1.00	.921	2.677	4.646	2.165	.669	.374	A
SHU117.0125.1.16.IK	1.25	1.171	2.480	4.843	1.969	1.181	.659	C
SHU117.0125.2.16.IK	1.25	1.171	3.465	5.827	2.953	1.181	.659	C
SHU117.0125.3.16.IK	1.25	1.171	4.449	6.811	3.937	1.181	.659	C
SHU117.0610.1.10.IK	1.00	.921	2.008	3.976	1.575	.625	.425	A1
SHU117.0910.1.10.IK	1.00	.921	2.480	4.449	1.969	.866	.472	A
SHU117.0910.2.10.IK	1.00	.921	3.268	5.236	2.756	.866	.472	A
SHU117.1000.1.10.IK	1.00	.921	2.480	4.449	1.969	.866	.472	B
SHU117.1000.2.10.IK	1.00	.921	3.268	5.236	2.756	.866	.472	B
SHU117.1250.1.16.IK	1.25	1.171	2.480	4.843	1.969	1.496	.866	D
SHU117.1250.2.16.IK	1.25	1.171	3.465	5.827	2.953	1.496	.866	D
SHU117.1250.3.16.IK	1.25	1.171	4.449	6.811	3.937	1.496	.866	D
SHU117.1410.1.08.IK	1.00	.921	1.654	3.622	1.181	.551	.378	F
SHU117.1410.1.3.08.IK	1.00	.921	1.260	3.228	.787	.551	.378	G
SHU117.1410.2.08.IK	1.00	.921	2.047	4.016	1.575	.551	.378	F

Further sizes upon request

Dimensions in inch

For torque specification of the screw, please see Technical Instructions.

Coolant supply G1/8 is not included - separate order required!

Spare Parts

Toolholder	Clamping Screw	TORX PLUS® Wrench
SHU117...10	4.09T15P	T15PQ
SHU117...16	5.12T20P	T20PQ
SHU117...08	030.3509.T15P	T15PQ



Toolholder

SH117

with through coolant supply

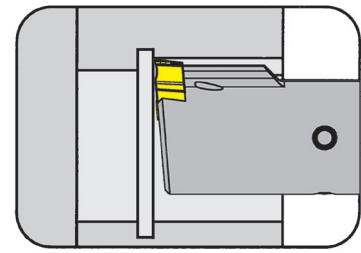

Bore Ø from 14 mm

Material of shank SH117: Steel / Material of shank SHM117: Carbide - Giving a good vibration resistance

for Insert

Type S117
SU117

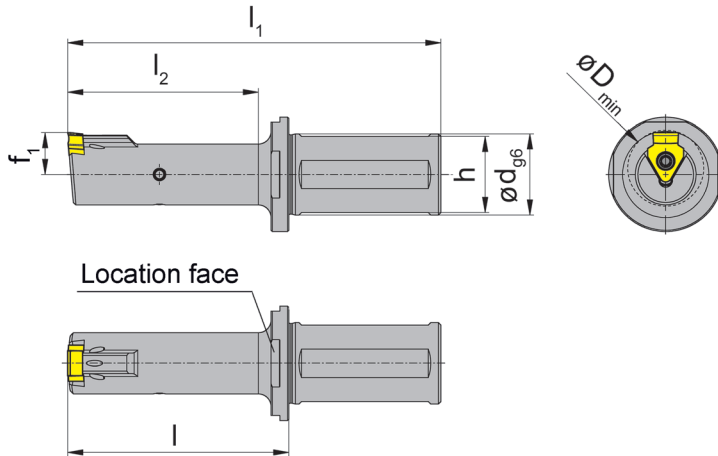

with through coolant supply

Part number	d	h	l	l ₁	l ₂	D _{min}	f ₁	Form
SH117.0025.1.10.IK	25	23	63	113	50	22	12.0	B
SH117.0025.2.10.IK	25	23	83	133	70	22	12.0	B
SH117.0032.1.16.IK	32	30	63	123	50	38	22.0	D
SH117.0032.2.16.IK	32	30	88	148	75	38	22.0	D
SH117.0032.3.16.IK	32	30	113	173	100	38	22.0	D
SH117.1425.1.08.IK	25	23	42	92	30	14	9.6	F
SH117.1425.1.3.08.IK	25	23	32	82	20	14	9.6	G
SH117.1425.2.08.IK	25	23	52	102	40	14	9.6	F
SH117.1725.1.10.IK	25	23	53	103	40	17	9.5	A
SH117.1725.2.10.IK	25	23	68	118	55	17	9.5	A
SH117.3032.1.16.IK	32	30	63	123	50	30	16.5	C
SH117.3032.2.16.IK	32	30	88	148	75	30	16.5	C
SH117.3032.3.16.IK	32	30	113	173	100	30	16.5	C
SH117.4032.1.16.IK	32	30	63	123	50	40	21.5	E
SH117.4032.2.16.IK	32	30	88	148	75	40	21.5	E
SH117.4032.3.16.IK	32	30	113	173	100	40	21.5	E

Further sizes upon request

Dimensions in mm

For torque specification of the screw, please see Technical Instructions.

Coolant supply G1/8 is not included - separate order required!

Spare Parts

Toolholder	Clamping Screw	TORX PLUS® Wrench
SH117...10	4.09T15P	T15PQ
SH117...16	5.12T20P	T20PQ
SH117...08	030.3509.T15P	T15PQ

Toolholder

SHMU117/SHM117

with through coolant supply

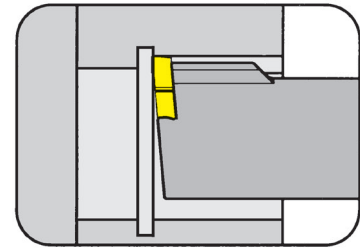

Bore Ø from .551"

Material of shank: Carbide - Giving a good vibration resistance

for Insert

Type S117
SU117

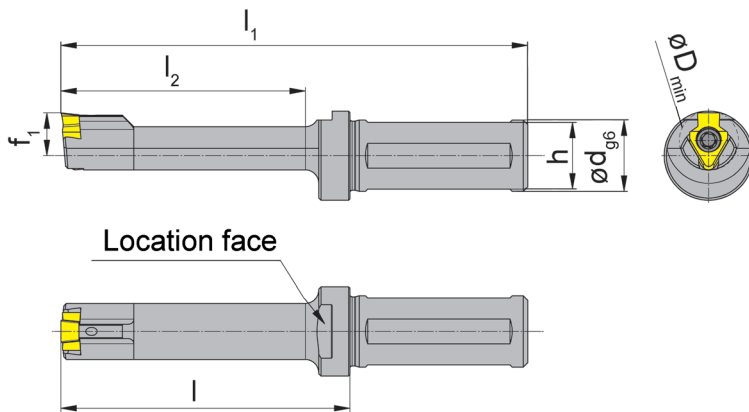

with through coolant supply

Part number	d	h	l	l ₁	l ₂	D _{min}	f ₁	Form
SHMU117.1462.3.08	.625	.586	2.559	4.134	2.165	.551	.378	F
SHM117.1416.3.08	16	15	65	105	55	14	9.6	F

Further sizes upon request

Dimensions in inch and mm

For torque specification of the screw, please see Technical Instructions.

Spare Parts

Toolholder	Clamping Screw	TORX PLUS® Wrench
SHM...14	030.3509.T15P	T15PQ



Toolholder

SH117

with through coolant supply

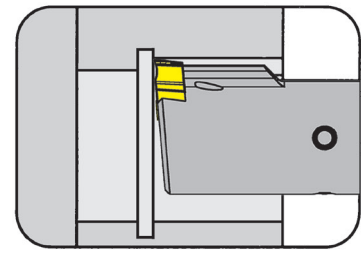

Bore \varnothing from 14 mm

Material of shank SH117: Steel

for Insert

Type S117
SU117

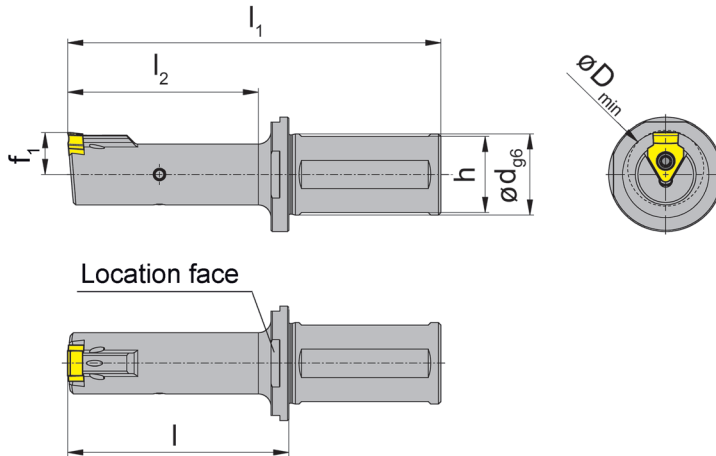

with through coolant supply

Part number	d	h	l	l ₁	l ₂	D _{min}	f ₁	Form
SH117.1425.1.3.08.IK	25	23	32	82	20	14	9.6	G
SH117.1425.1.08.IK	25	23	42	92	30	14	9.6	F
SH117.1425.2.08.IK	25	23	52	102	40	14	9.6	F
SH117.1725.1.10.IK	25	23	53	103	40	17	9.5	A
SH117.1725.2.10.IK	25	23	68	118	55	17	9.5	A
SH117.0025.1.10.IK	25	23	63	113	50	22	12.0	B
SH117.0025.2.10.IK	25	23	83	133	70	22	12.0	B
SH117.3032.1.16.IK	32	30	63	123	50	30	16.5	C
SH117.3032.2.16.IK	32	30	88	148	75	30	16.5	C
SH117.3032.3.16.IK	32	30	113	173	100	30	16.5	C
SH117.0032.1.16.IK	32	30	63	123	50	38	22.0	D
SH117.0032.2.16.IK	32	30	88	148	75	38	22.0	D
SH117.0032.3.16.IK	32	30	113	173	100	38	22.0	D

Further sizes upon request

Dimensions in mm

For torque specification of the screw, please see Technical Instructions.

Coolant supply G1/8 is not included - separate order required!

X

Spare Parts

Toolholder	Clamping Screw	TORX PLUS® Wrench
SH117...08	030.3509.T15P	T15PQ
SH117...10	4.09T15P	T15PQ
SH117...16	5.12T20P	T20PQ

Toolholder

SH117

with through coolant supply

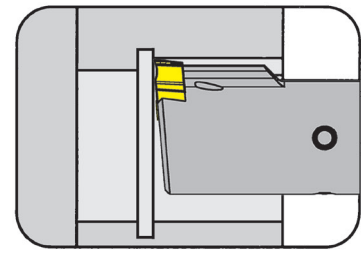

Bore Ø from 40 mm

Material of shank SH117: Steel

for Insert

Type S117
SU117

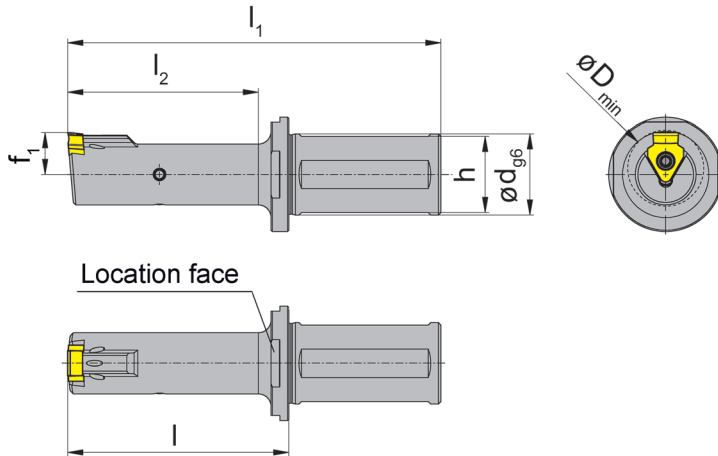

with through coolant supply

Part number	d	h	l	l ₁	l ₂	D _{min}	f ₁	Form
SH117.4032.1.16.IK	32	30	63	123	50	40	21.5	E
SH117.4032.2.16.IK	32	30	88	148	75	40	21.5	E
SH117.4032.3.16.IK	32	30	113	173	100	40	21.5	E
SH117.4032.2.20.IK	32	30	113	173	100	40	21.0	H
SH117.4032.3.20.IK	32	30	163	223	150	40	21.0	H
SH117.5040.2.20.IK	40	38	115	175	100	50	26.5	I
SH117.5040.3.20.IK	40	38	165	225	150	50	26.5	I

Further sizes upon request

Dimensions in mm

For torque specification of the screw, please see Technical Instructions.

Coolant supply G1/8 is not included - separate order required!

Spare Parts

Toolholder	Clamping Screw	TORX PLUS® Wrench
SH117...16	5.12T20P	T20PQ
SH117...20	6.17 T20P	T20PQ



Toolholder

SH117

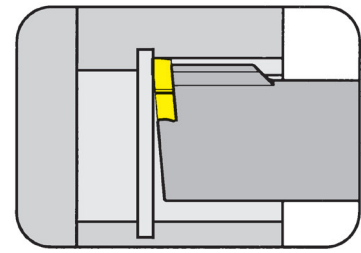

Bore Ø from 14 mm

only usable for broaching devices EWSP20, BENZ LinA 4.0 with IK

for Insert

Type S117
SU117

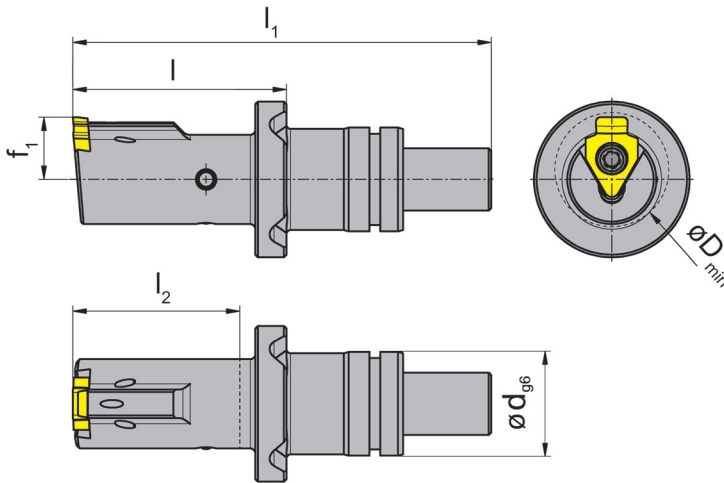

Part number	d	l	l ₁	l ₂	D _{min}	f ₁	Form
SH117.1420.E5.08.IK	20	42.5	82.0	32	14	9.6	F
SH117.1720.E5.10.IK	20	41.0	80.5	32	17	9.5	A
SH117.1720.E6.10.IK	20	60.0	99.5	51	17	9.5	A
SH117.2220.E5.10.IK	20	41.0	80.5	32	22	12.0	B
SH117.2220.E6.10.IK	20	60.0	99.5	51	22	12.0	B

Further sizes for other device interfaces upon request

Dimensions in mm

For torque specification of the screw, please see Technical Instructions.

X

Spare Parts

Toolholder	Clamping Screw	TORX PLUS® Wrench
SH117.1420.E5.08.IK	030.3509.T15P	T15PQ
SH117...10	4.09T15P	T15PQ

X50

Call Us Toll Free (888) 818-4676

Toolholder

SH117

Bore Ø from 14 mm

only usable for broaching devices EWS-Slot, BENZ LinA, Sauter

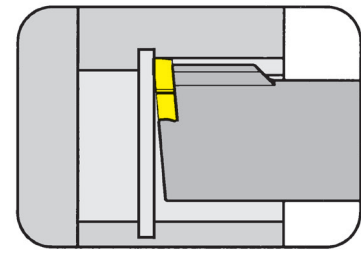

for Insert

Type S117
SU117

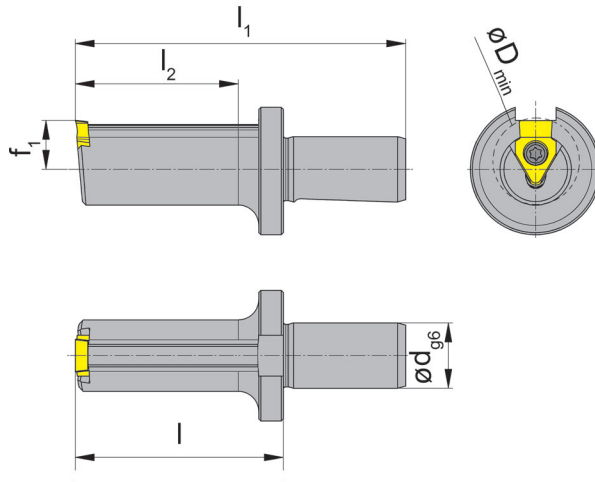

external and internal

Part number	d	l	l ₁	l ₂	D _{min}	f ₁	Form
SH117.1416.E1.08	16	46	76	35	14	9.6	F
SH117.1716.E0.10	16	31	61	20	17	9.5	A
SH117.1716.E1.10	16	43	73	35	17	9.5	A
SH117.1716.E2.10	16	51	81	40	17	9.5	A
SH117.1716.E3.10	16	64	94	53	17	9.5	A
SH117.0016.E1.10	16	43	73	35	22	12.0	B
SH117.0016.E2.10	16	51	81	40	22	12.0	B
SH117.0016.E3.10	16	64	94	53	22	12.0	B

Further sizes upon request

Dimensions in mm

For torque specification of the screw, please see Technical Instructions.

Spare Parts

Toolholder	Clamping Screw	TORX PLUS® Wrench
SH117.1416.E1.08	030.3509.T15P	T15PQ
SH117...10	4.09T15P	T15PQ



Toolholder

SH117/H117

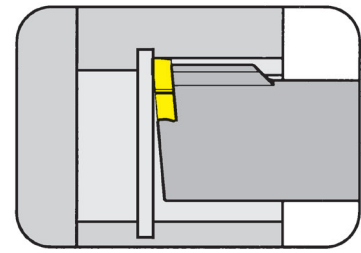

Bore Ø from 14 mm

for broaching device Schwarzer

for Insert

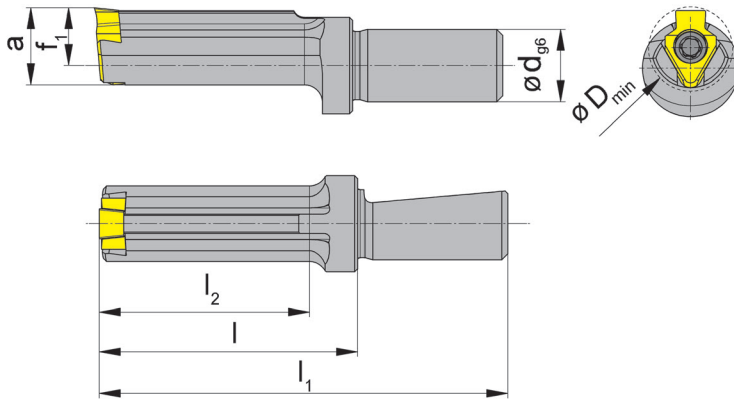

Type S117
SU117

Part number	d	l	l ₁	l ₂	D _{min}	f ₁	a	Form
SH117.1412.S1.08	12	33	58	25	14	9.6	12.80	F
SH117.1412.S2.08	12	43	68	35	14	9.6	12.80	F
H117.1712.1439	12	33	58	25	17	9.5	16.00	A
H117.1712.1407	12	43	68	35	17	9.5	16.00	A
H117.2212.1441	12	33	58	25	22	12.0	20.75	B
H117.2212.1442	12	43	68	35	22	12.0	20.75	B
H117.3012.1440	12	33	58	25	30	16.5	28.50	C
H117.3012.1419	12	43	68	35	30	16.5	28.50	C

Further sizes for other device interfaces upon request

Dimensions in mm

For torque specification of the screw, please see Technical Instructions.

X

Spare Parts

Toolholder	Clamping Screw	TORX PLUS® Wrench
SH117.1412....	030.3509.T15P	T15PQ
H117...	4.09T15P	T15PQ
H117.3012.1...	5.12T20P	T20PQ

Toolholder

SH117

with through coolant supply

Bore Ø from 14 mm

for broaching device Schwarzer „2in1“

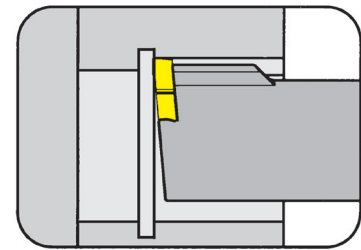

for Insert

Type S117
SU117

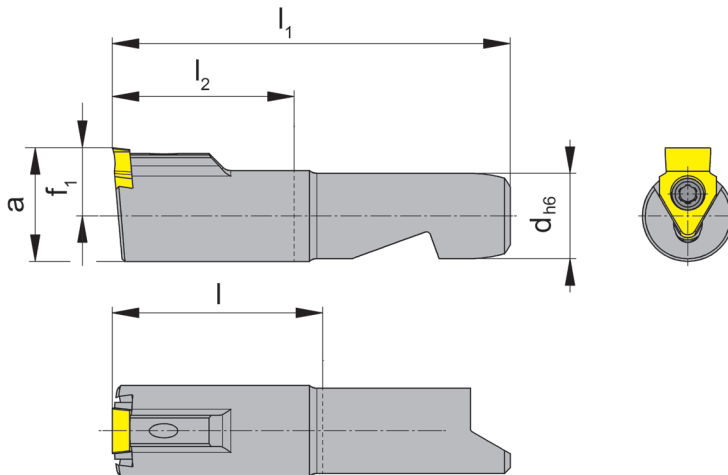

Part number	d	l	l ₁	l ₂	D _{min}	f ₁	a	Form
SH117.0932.S.08	15	37	70	32	14	9.6	12.8	F
SH117.0932.S.10	15	37	70	32	17	9.5	16.0	A
SH117.1532.S.10	15	37	70	32	22	12.0	20.0	B
SH117.1538.S.16	15	43	76	38	30	15.0	24.0	C
SH117.1544.S.16	15	49	82	44	30	15.0	24.0	C

Further sizes for other device interfaces upon request

Dimensions in mm

For torque specification of the screw, please see Technical Instructions.

Spare Parts

Toolholder	Clamping Screw	TORX PLUS® Wrench
SH117.0932.S.08	030.3509.T15P	T15PQ
SH117...10	4.09T15P	T15PQ
SH117.1...16	5.12T20P	T20PQ

Toolholder

SH117

Bore Ø from 22 mm

for broaching device AP2R/AP3R

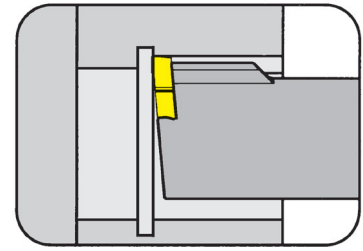

for Insert

Type S117
SU117

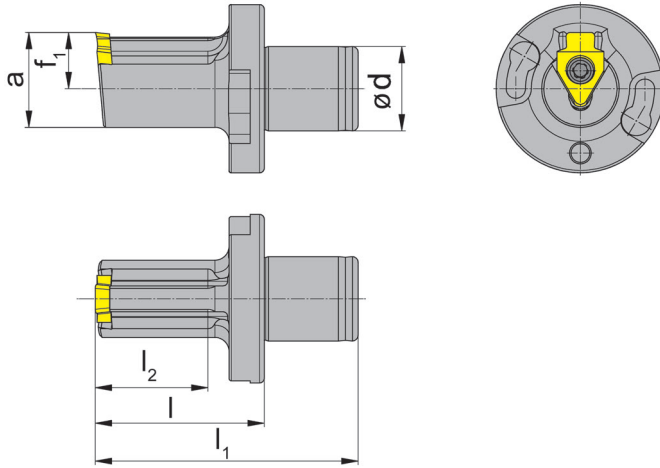

Part number	d	l	l ₁	l ₂	D _{min}	f ₁	a	Form
SH117.2218.A1.10	18	36	56	24	22	12	20.25	B

Further sizes for other device interfaces upon request

Dimensions in mm

For torque specification of the screw, please see Technical Instructions.

X

Spare Parts

Toolholder	Clamping Screw	TORX PLUS® Wrench
SH117.2218.A1.10	4.09T15P	T15PQ

X54

Call Us Toll Free (888) 818-4676

Toolholder

SH117

Bore Ø from 17 mm

for broaching device WTO

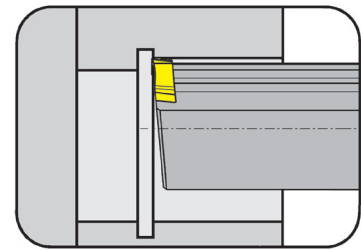

for Insert

Type S117
SU117

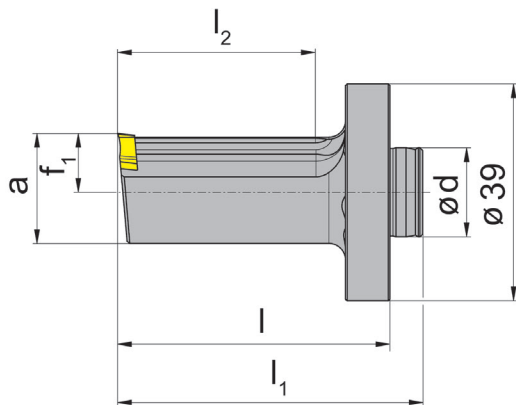

Part number	d	l	l ₁	l ₂	D _{min}	f ₁	a	Form
SH117.1716.W1.10	16	49	55	35	17	8.3	15.1	A
SH117.2216.W1.10	16	49	55	35	22	10.6	19.8	B
SH117.2616.W1.16	16	49	55	35	26	12.6	23.5	C

Further sizes upon request

Dimensions in mm

For torque specification of the screw, please see Technical Instructions.

Spare Parts

Toolholder	Clamping Screw	TORX PLUS® Wrench
SH117...	4.09T15P	T15PQ
SH117.2616.W1.16	5.12T20P	T20PQ

Toolholder

SHU117

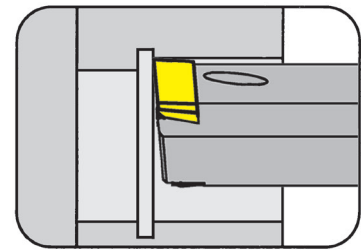

Bore Ø from .531"

for Insert

Type S117...SQ

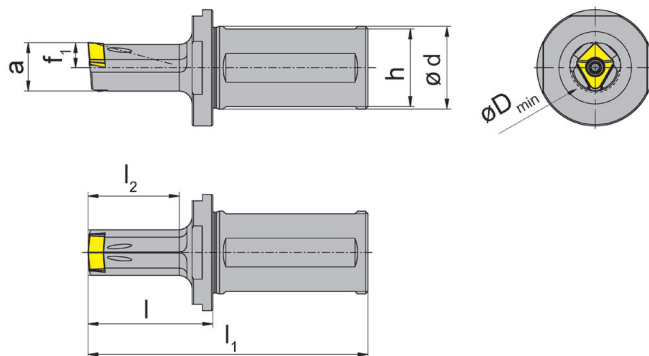

Square Broaching

Part number	d	h	l	l ₁	l ₂	D _{min}	f ₁	a
SHU117.1310.SQ.1.08.IK	1.000	.921	1.504	3.472	.992	.531	.256	.504
SHU117.1510.SQ.1.10.IK	1.000	.921	1.504	3.472	.992	.610	.295	.577
SHU117.1712.SQ.1.12.IK	1.250	1.171	1.701	4.063	1.189	.689	.335	.650
SHU117.1912.SQ.1.16.IK	1.250	1.171	1.898	4.260	1.386	.768	.382	.736

Further sizes for other device interfaces upon request

Dimensions in inch

For torque specification of the screw, please see Technical Instructions.



Spare Parts

Toolholder	Clamping Screw	TORX PLUS® Wrench
SH117.1310...	030.3509.T15P	T15PQ
SH117...10.IK/...12.IK	4.09T15P	T15PQ
SH117.1912...	5.12T20P	T20PQ

Toolholder

SH117

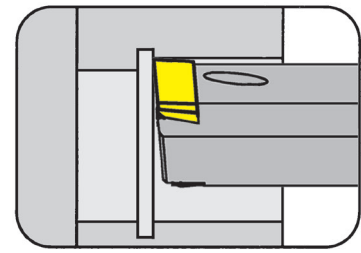

Bore Ø from 13.5 mm

for Insert

Type S117...SQ

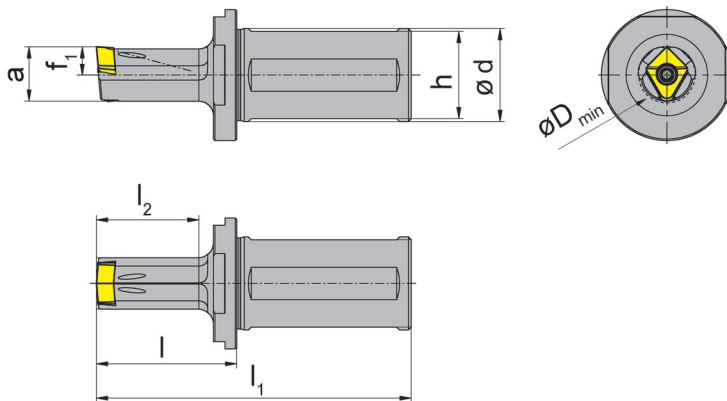

Square Broaching

Part number	d	h	l	l ₁	l ₂	D _{min}	f ₁	a
SH117.1325.SQ.1.08.IK	25	23	38	88	25	13.5	6.5	12.8
SH117.1525.SQ.1.10.IK	25	23	38	88	25	15.5	7.5	14.65
SH117.1732.SQ.1.12.IK	32	30	43	103	30	17.5	8.5	16.50
SH117.1932.SQ.1.16.IK	32	30	48	108	35	19.5	9.7	18.70

Further sizes upon request

Dimensions in mm

For torque specification of the screw, please see Technical Instructions.

Spare Parts

Toolholder	Clamping Screw	TORX PLUS® Wrench
SH117.1325.SQ.1.08.IK	030.3509.T15P	T15PQ
SH117...10.IK/...12.IK	4.09T15P	T15PQ
SH117.1932.SQ.1.16.IK	5.12T20P	T20PQ



Toolholder

SH117

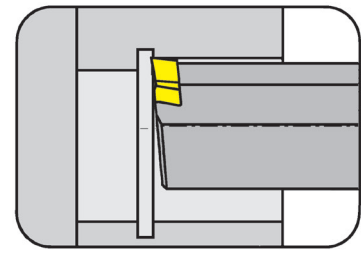

Bore Ø from 11.5 mm

for Insert

Type S117

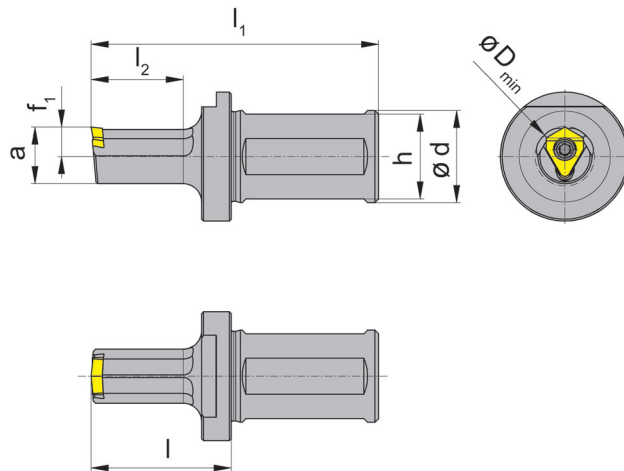

Hexagon socket

Part number	d	h	l	l ₁	l ₂	D _{min}	f ₁	a	Insert
SH117.1425.30.1.08.IK	25	23	33	83	20	14.2	6.75	13	S117.SW14.08...
SH117.1625.30.1.10.IK	25	23	38	88	25	16.2	7.75	15	S117.SW16.10...
SH117.2432.30.1.12.IK	32	30	43	103	30	11.5	24.30	22	S117.SW24.12...
SH117.3032.30.1.16.IK	32	30	53	113	40	30.5	14.50	28	S117.SW30.16...
SH117.1425.30.1.08	25	23	33	83	20	14.2	6.75	13	S117.SW14.08...
SH117.1625.30.1.10	25	23	38	88	25	16.2	7.75	15	S117.SW16.10...
SH117.2432.30.1.12	32	30	43	103	30	24.3	11.50	22	S117.SW24.12...
SH117.3032.30.1.16	32	30	53	113	40	30.3	14.50	28	S117.SW30.16...

Further sizes upon request

Dimensions in mm

For torque specification of the screw, please see Technical Instructions.



Spare Parts

Toolholder	Clamping Screw	TORX PLUS® Wrench
SH117...08	030.3509.T15P	T15PQ
SH117...10.12	4.09T15P	T15PQ
SH117...16	5.12T20P	T20PQ

Insert

SU117

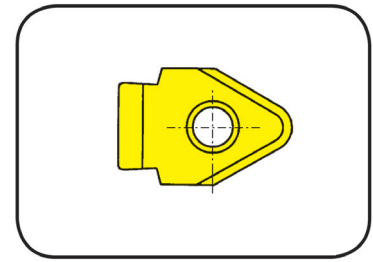

Bore Ø from
Depth of groove up to

.551"
.335"

for Toolholder

Type SH117
SHU117
SHM117
SHMU117
H117

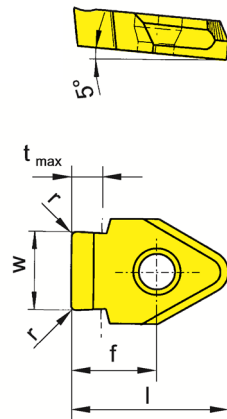

Keyways according to
Inch Standards

Part number	w	l	r	D _{min}	t _{max}	f	Form	TA45
SU117.1250.04.08	.126	.512	.004	.551	.071	.236	G	▲
SU117.1562.04.08	.157	.512	.004	.551	.087	.236	F	▲
SU117.1875.08.08	.189	.512	.008	.551	.106	.236	F	▲
SU117.1250.04.10	.126	.551	.004	.625	.071	.236	A1	▲
SU117.1562.04.10	.157	.551	.004	.625	.087	.236	A1	▲
SU117.1875.08.10	.189	.571	.008	.669	.106	.256	A	▲
SU117.2500.08.10	.251	.571	.008	.669	.134	.256	A	▲
SU117.2812.08.10	.283	.630	.008	.866	.161	.315	B	▲
SU117.3125.08.10	.314	.630	.008	.866	.161	.315	B	▲
SU117.3750.12.14	.377	.815	.012	1.181	.197	.441	C	▲
SU117.4375.12.14	.439	.815	.012	1.496	.224	.441	D	▲
SU117.5000.12.14	.502	.815	.012	1.496	.260	.441	D	▲
SU117.5000.20.14	.502	.815	.020	1.496	.335	.441	D	▲

▲ on stock Δ 4 weeks x upon request

- recommended
- alternative recommendation
- not suitable

- uncoated grades
- coated grades
- brazed/Cermet

Dimensions in inch

P	•
M	•
K	•
N	•
S	•
H	-

Carbide grades

Note:

The insert form must correspond to the holder form. E.g.: Form A Toolholder = Form A Insert

Insert

SU117

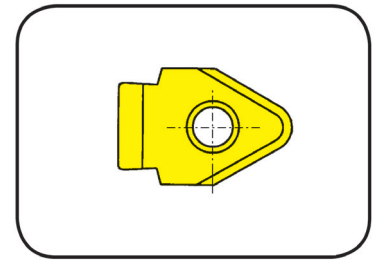

Bore Ø from
Depth of groove up to

.551"
.335"

for Toolholder

Type SH117
SHU117
SHM117
SHMU117
H117

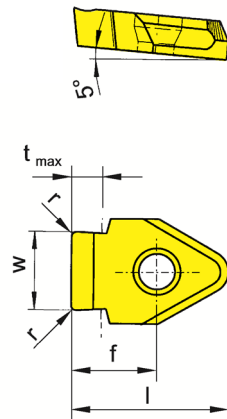

Keyways according to
Inch Standards

Part number	w	l	r	D _{min}	t _{max}	f	Form	AN45
SU117.1250.4.08.A1	.126	.512	.004	.551	.071	.236	G	▲
SU117.1250.4.10.A1	.126	.551	.004	.625	.071	.236	A1	▲
SU117.1562.4.08.A1	.157	.512	.004	.551	.087	.236	F	▲
SU117.1562.4.10.A1	.157	.551	.004	.625	.087	.236	A1	▲
SU117.1875.8.08.A1	.189	.512	.008	.551	.106	.236	F	▲
SU117.1875.8.10.A1	.189	.571	.008	.669	.106	.256	A	▲
SU117.2500.8.10.A1	.251	.571	.008	.669	.134	.256	A	▲
SU117.2812.8.10.A1	.283	.630	.008	.866	.161	.315	B	▲
SU117.3125.8.10.A1	.314	.630	.008	.866	.161	.315	B	▲
SU117.3750.1.14.A1	.377	.815	.012	1.181	.197	.441	C	▲
SU117.4375.1.14.A1	.439	.815	.012	1.496	.224	.441	D	▲
SU117.5000.1.14.A1	.502	.815	.012	1.496	.260	.441	D	▲
SU117.5000.2.14.A1	.502	.815	.020	1.496	.335	.441	D	▲

▲ on stock Δ 4 weeks x upon request

- recommended
- alternative recommendation
- not suitable

- uncoated grades
- coated grades
- brazed/Cermet

Dimensions in inch

P	●
M	○
K	●
N	●
S	○
H	-

Carbide grades

Note:

The insert form must correspond to the holder form. E.g.: Form A Toolholder = Form A Insert

Insert

SU117

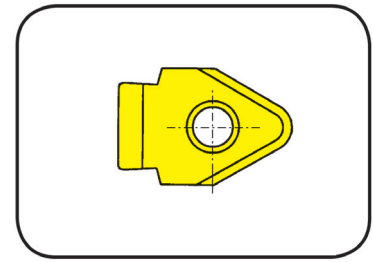

Bore Ø from .551"
Depth of groove up to .335"

for Toolholder

Type SH117
SHU117
SHM117
SHMU117
H117

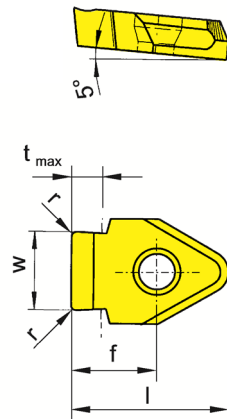

Keyways according to Inch Standards

Part number	w	l	r	D _{min}	t _{max}	f	Form	AN45
SU117.1250.4.08.B1	.126	.512	.004	.551	.071	.236	G	▲
SU117.1250.4.10.B1	.126	.551	.004	.625	.071	.236	A1	▲
SU117.1562.4.08.B1	.157	.512	.004	.551	.087	.236	F	▲
SU117.1562.4.10.B1	.157	.551	.004	.625	.087	.236	A1	▲
SU117.1875.8.08.B1	.189	.512	.008	.551	.106	.236	F	▲
SU117.1875.8.10.B1	.189	.571	.008	.669	.106	.256	A	▲
SU117.2500.8.10.B1	.251	.571	.008	.669	.134	.256	A	▲
SU117.2812.8.10.B1	.283	.630	.008	.866	.161	.315	B	▲
SU117.3125.8.10.B1	.314	.630	.008	.866	.161	.315	B	▲
SU117.3750.1.14.B1	.377	.815	.012	1.181	.197	.441	C	▲
SU117.4375.1.14.B1	.439	.815	.012	1.496	.224	.441	D	▲
SU117.5000.1.14.B1	.502	.815	.012	1.496	.260	.441	D	▲
SU117.5000.2.14.B1	.502	.815	.020	1.496	.335	.441	D	▲

▲ on stock Δ 4 weeks x upon request
● recommended
○ alternative recommendation
- not suitable

■ uncoated grades
■ coated grades
■ brazed/Cermet

Dimensions in inch

P	•
M	○
K	•
N	•
S	○
H	-

Carbide grades

Note:

The insert form must correspond to the holder form. E.g.: Form A Toolholder = Form A Insert



Broaching



Insert

S117

Tolerance grade C11

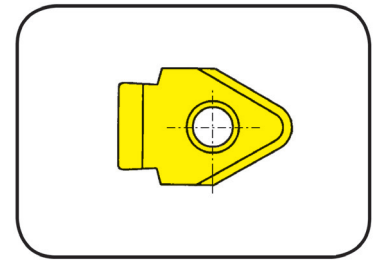

Bore Ø from	.551"
Depth of groove up to	.335"

Recommended for: Broaching units

for Toolholder

- Type
- SH117
 - SHU117
 - SHM117
 - SHMU117
 - H117

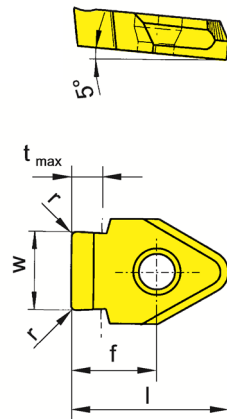

Keyways according to DIN138

Part number	w	l	r	D _{min}	t _{max}	f	Form	AN45
S117.0310.04.08.A1	.122	.512	.014	.551	.079	.236	G	▲
S117.0412.05.08.A1	.162	.512	.020	.551	.083	.236	F	▲
S117.0612.09.10.A1	.241	.630	.033	.866	.102	.315	B	▲
S117.0713.11.10.A1	.281	.630	.033	.866	.130	.315	B	▲
S117.0813.11.10.A1	.320	.630	.041	.866	.134	.315	B	▲
S117.1013.11.14.A1	.399	.815	.041	1.181	.165	.441	D	▲
S117.1215.14.14.A1	.478	.815	.053	1.496	.201	.441	D	▲
S117.1215.18.14.A1	.478	.815	.069	1.496	.260	.441	D	▲
S117.1215.23.14.A1	.478	.815	.089	1.496	.335	.441	D	▲

▲ on stock Δ 4 weeks x upon request

- recommended
- alternative recommendation
- not suitable

- uncoated grades
- coated grades
- brazed/Cermet

Dimensions in inch

P	●
M	○
K	●
N	●
S	○
H	-

Carbide grades

Note:

The insert form must correspond to the holder form. E.g.: Form A Toolholder = Form A Insert

Ordering note:

For Dimensions of Groove DIN please see Technical Instructions.

X

Insert

S117

Tolerance grade D10

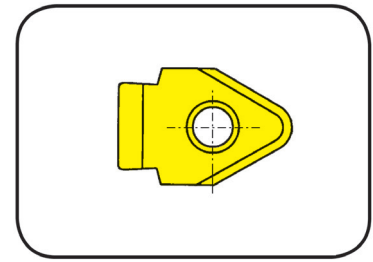

Bore Ø from	.551"
Depth of groove up to	.268"

Recommended for: Broaching units

for Toolholder

Type SH117
SHU117
SHM117
SHMU117
H117

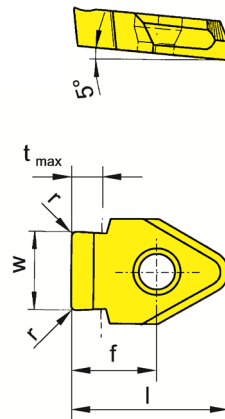

Part number	w	l	r	D _{min}	t _{max}	f	Form	AN45
S117.0305.01.08.A1	.120	.512	.005	.551	.079	.236	G	▲
S117.0407.01.08.A1	.160	.512	.005	.551	.087	.236	F	▲
S117.0507.02.08.A1	.200	.512	.008	.551	.114	.236	F	▲
S117.0507.02.10.A1	.200	.571	.008	.551	.110	.256	A	▲
S117.0607.02.10.A1	.239	.571	.008	.669	.138	.256	A	▲
S117.0808.02.10.A1	.318	.630	.008	.866	.169	.315	B	▲
S117.1008.03.14.A1	.397	.815	.012	1.181	.173	.441	C	▲
S117.1210.03.14.A1	.476	.815	.012	1.496	.232	.441	D	▲
S117.1410.03.16.A1	.555	.815	.012	1.575	.268	.441	E	▲

▲ on stock Δ 4 weeks x upon request

- recommended
- alternative recommendation
- not suitable

- uncoated grades
- coated grades
- brazed/Cermet

Dimensions in inch

P	●
M	○
K	●
N	●
S	○
H	-

Carbide grades

Note:

The insert form must correspond to the holder form. E.g.: Form A Toolholder = Form A Insert

Ordering note:

For Dimensions of Groove DIN please see Technical Instructions.



Insert

S117

Tolerance grade H9

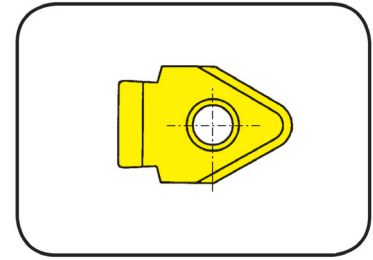

Bore Ø from	.551"
Depth of groove up to	.268"

Recommended for: Broaching units

for Toolholder

Type SH117
SHU117
SHM117
SHMU117
H117

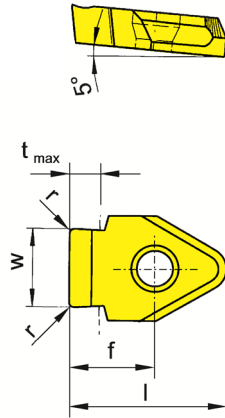

Part number	w	l	r	D _{min}	t _{max}	f	Form	AN45
S117.0302.01.08.A1	.119	.512	.005	.551	.079	.236	G	▲
S117.0402.01.08.A1	.158	.512	.005	.551	.087	.236	F	▲
S117.0502.02.08.A1	.198	.512	.008	.551	.114	.236	F	▲
S117.0502.02.10.A1	.198	.571	.008	.669	.110	.256	A	▲
S117.0602.02.10.A1	.237	.571	.008	.669	.138	.256	A	▲
S117.0803.02.10.A1	.316	.630	.008	.866	.169	.315	B	▲
S117.1003.03.14.A1	.395	.815	.012	1.181	.173	.441	C	▲
S117.1203.03.14.A1	.474	.815	.012	1.496	.232	.441	D	▲
S117.1403.03.16.A1	.553	.815	.012	1.575	.268	.441	E	▲

▲ on stock Δ 4 weeks x upon request

- recommended
- alternative recommendation
- not suitable

- uncoated grades
- coated grades
- brazed/Cermet

Dimensions in inch

P	●
M	○
K	●
N	●
S	○
H	-

Carbide grades

Note:

The insert form must correspond to the holder form. E.g.: Form A Toolholder = Form A Insert

Ordering note:

For Dimensions of Groove DIN please see Technical Instructions.

X

Insert

S117

Tolerance grade P9

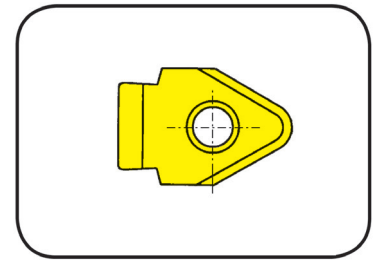

Bore Ø from	.551"
Depth of groove up to	.268"

Recommended for: Broaching units

for Toolholder

Type SH117
SHU117
SHM117
SHMU117
H117

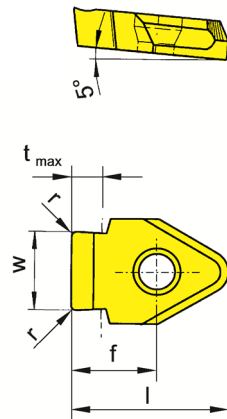

Keyways according to
DIN6885

Part number	w	l	r	D _{min}	t _{max}	f	Form	AN45
S117.0298.01.08.A1	.118	.512	.005	.551	.079	.236	G	▲
S117.0397.01.08.A1	.157	.512	.005	.551	.087	.236	F	▲
S117.0497.02.08.A1	.196	.512	.008	.551	.114	.236	F	▲
S117.0497.02.10.A1	.196	.571	.008	.669	.110	.256	A	▲
S117.0597.02.10.A1	.235	.571	.008	.669	.138	.256	A	▲
S117.0796.02.10.A1	.314	.630	.008	.866	.169	.315	B	▲
S117.0996.03.14.A1	.393	.815	.012	1.181	.173	.441	C	▲
S117.1196.03.14.A1	.471	.815	.012	1.496	.232	.441	D	▲
S117.1396.03.16.A1	.550	.815	.012	1.575	.268	.441	E	▲

▲ on stock Δ 4 weeks x upon request

- recommended
- alternative recommendation
- not suitable

- uncoated grades
- coated grades
- brazed/Cermet

Dimensions in inch

P	●
M	○
K	●
N	●
S	○
H	-

Carbide grades

Note:

The insert form must correspond to the holder form. E.g.: Form A Toolholder = Form A Insert

Ordering note:

For Dimensions of Groove DIN please see Technical Instructions.

Insert

S117

Tolerance grade JS9

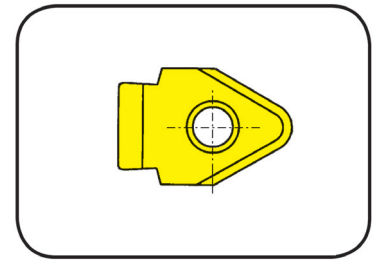

Bore Ø from	.551"
Depth of groove up to	.335"

Recommended for: Broaching units

for Toolholder

Type SH117
SHU117
SHM117
SHMU117
H117

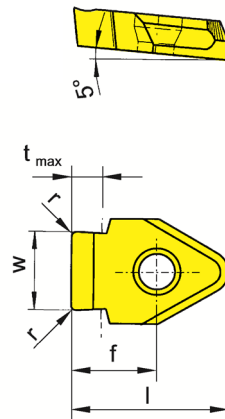

Keyways according to
DIN6885

Part number	w	l	r	D _{min}	t _{max}	f	Form	AN45
S117.0300.01.08.A1	.119	.512	.005	.551	.079	.236	G	▲
S117.0400.01.08.A1	.158	.512	.005	.551	.087	.236	F	▲
S117.0500.02.08.A1	.197	.512	.008	.551	.114	.236	F	▲
S117.0500.02.10.A1	.197	.571	.008	.669	.110	.256	A	▲
S117.0600.02.10.A1	.237	.571	.008	.669	.138	.256	A	▲
S117.0800.02.10.A1	.315	.630	.008	.866	.169	.315	B	▲
S117.1000.03.14.A1	.394	.815	.012	1.181	.173	.441	C	▲
S117.1200.03.14.A1	.473	.815	.012	1.496	.232	.441	D	▲
S117.1200.05.14.A1	.472	.815	.020	1.496	.335	.441	D	▲
S117.1400.03.16.A1	.552	.815	.012	1.575	.268	.441	E	▲

▲ on stock Δ 4 weeks x upon request

- recommended
- alternative recommendation
- not suitable

- uncoated grades
- coated grades
- brazed/Cermet

Dimensions in inch

P	●
M	○
K	●
N	●
S	○
H	-

Carbide grades

Note:

Insert S117.1200.05.14 = Nw from .472"

Ordering note:

For Dimensions of Groove DIN please see Technical Instructions.

X

Insert

S117

Bore Ø from .551"

Recommended for: Broaching units

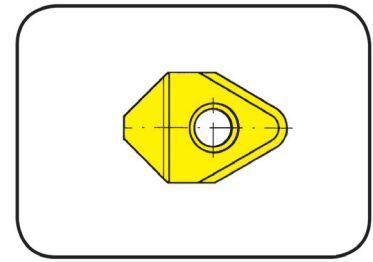

for Toolholder

Type SH117
SHU117
SHM117
SHMU117
H117

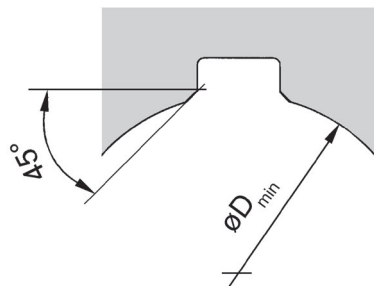
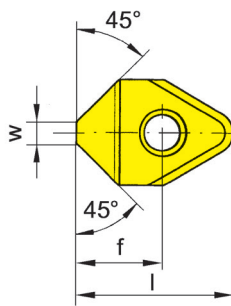
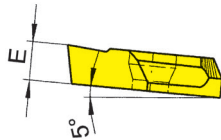

Chamfering

Part number	w	l	D _{min}	f	Form	AN45
S117.1545.10.A1	.059	.630	.669	.315	A	▲
S117.2445.08.A1	.094	.512	.551	.236	F	▲
S117.3045.10.A1	.118	.630	.866	.315	B	▲
S117.6045.14.A1	.236	.827	1.181	.441	C/D	▲

▲ on stock Δ 4 weeks x upon request

● recommended
○ alternative recommendation
- not suitable

□ uncoated grades
■ coated grades
■ brazed/Cermet

Dimensions in inch

P	●
M	○
K	●
N	●
S	○
H	-

Carbide grades

Note:

The insert form must correspond to the holder form. E.g.: Form A Toolholder = Form A Insert

Insert

S117

Hexagon socket SW = .551 - 1.417"

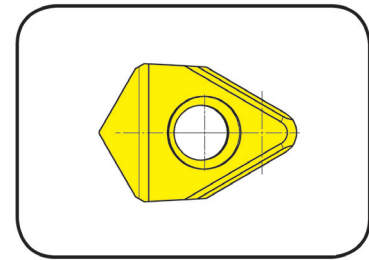

Recommended for: Broaching units

for Toolholder

Type SH117
SHU117
SHM117
SHMU117
H117

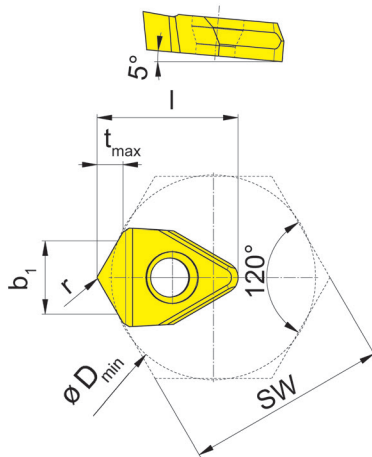

Hexagon socket

Part number	SW	b ₁	l	r	D _{min}	t _{max}	Toolholder	AN45
S117.SW14.08.A1	.551 - .630	.194 - .228	.512	.008	.559 - .638	.075	SH117.1425.30.1.08	▲
S117.SW16.10.A1	.630 - .866	.228 - .332	.551	.008	.638 - .874	.098	SH117.1625.30.1.10	▲
S117.SW24.12.A1	.945 - 1.063	.343 - .394	.669	.012	.957 - 1.075	.118	SH117.2432.30.1.12	▲
S117.SW30.16.A1	1.181 - 1.417	.446 - .550	.815	.012	1.193 - 1.429	.165	SH117.3032.30.1.16	▲

▲ on stock Δ 4 weeks x upon request

● recommended
○ alternative recommendation
- not suitable

□ uncoated grades
■ coated grades
■ brazed/Cermet

Dimensions in inch

P	●
M	○
K	●
N	●
S	○
H	-

Carbide grades

Broaching



Insert

S117

Tolerance grade C11

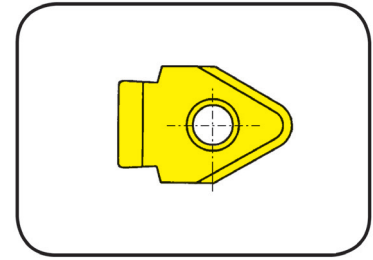

Bore Ø from	.551"
Depth of groove up to	.335"

Recommended for: conventional broaching

for Toolholder

- Type
- SH117
 - SHU117
 - SHM117
 - SHMU117
 - H117

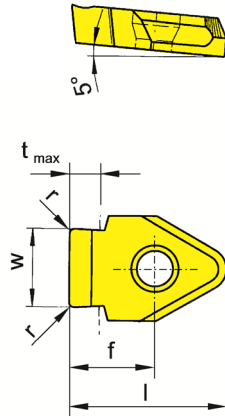

Keyways according to DIN138

Part number	w	l	r	D _{min}	t _{max}	f	Form	AN45
S117.0310.04.08.B1	.122	.512	.014	.551	.079	.236	G	▲
S117.0412.05.08.B1	.162	.512	.020	.551	.083	.236	F	▲
S117.0612.09.10.B1	.241	.630	.033	.866	.102	.315	B	▲
S117.0713.11.10.B1	.281	.630	.033	.866	.130	.315	B	▲
S117.0813.11.10.B1	.320	.630	.041	.866	.134	.315	B	▲
S117.1013.11.14.B1	.399	.815	.041	1.181	.165	.441	D	▲
S117.1215.14.14.B1	.478	.815	.053	1.496	.201	.441	D	▲
S117.1215.18.14.B1	.478	.815	.069	1.496	.260	.441	D	▲
S117.1215.23.14.B1	.478	.827	.089	1.496	.335	.441	D	▲
S117.1417.14.16.B1	.558	.827	.053	1.575	.268	.441	E	▲
S117.1617.18.18.B1	.637	1.142	.069	1.575	.268	.615	H	▲
S117.1817.18.20.B1	.715	1.142	.069	1.969	.307	.615	I	▲
S117.2020.20.20.B1	.795	1.142	.078	1.969	.307	.615	I	▲

- ▲ on stock Δ 4 weeks x upon request
- recommended
- o alternative recommendation
- not suitable
- uncoated grades
- coated grades
- brazed/Cermet

Dimensions in inch

P	•
M	o
K	•
N	•
S	o
H	-

Carbide grades

Note:

The insert form must correspond to the holder form. E.g.: Form A Toolholder = Form A Insert

Ordering note:

For Dimensions of Groove DIN please see Technical Instructions.



Insert

S117

Tolerance grade D10

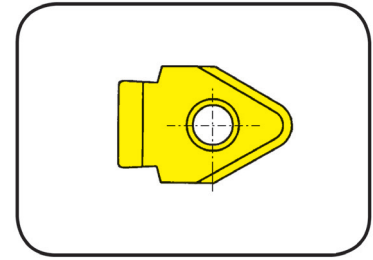

Bore Ø from	.551"
Depth of groove up to	.307"

Recommended for: conventional broaching

for Toolholder

Type SH117
SHU117
SHM117
SHMU117
H117

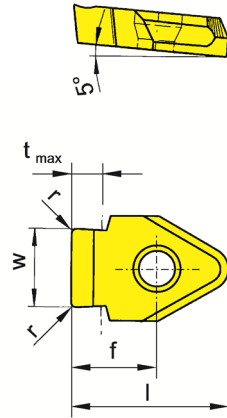

Keyways according to
DIN6885

Part number	w	l	r	D _{min}	t _{max}	f	Form	AN45
S117.0305.01.08.B1	.120	.512	.005	.551	.079	.236	G	▲
S117.0407.01.08.B1	.160	.512	.005	.551	.087	.236	F	▲
S117.0507.02.08.B1	.200	.512	.008	.551	.114	.236	F	▲
S117.0507.02.10.B1	.200	.571	.008	.669	.110	.256	A	▲
S117.0607.02.10.B1	.239	.571	.008	.669	.138	.256	A	▲
S117.0808.02.10.B1	.318	.630	.008	.866	.169	.315	B	▲
S117.1008.03.14.B1	.397	.815	.012	1.181	.173	.441	C	▲
S117.1210.03.14.B1	.476	.815	.012	1.496	.232	.441	D	▲
S117.1410.03.16.B1	.555	.815	.012	1.575	.268	.441	E	▲
S117.1610.03.18.B1	.634	1.055	.012	1.575	.268	.606	H	▲
S117.1810.03.20.B1	.713	1.055	.012	1.969	.307	.614	I	▲
S117.2012.05.20.B1	.792	1.055	.020	1.969	.335	.614	I	▲

▲ on stock Δ 4 weeks x upon request

● recommended
○ alternative recommendation
- not suitable

□ uncoated grades
■ coated grades
■ brazed/Cermet

Dimensions in inch

P	●
M	○
K	●
N	●
S	○
H	-

Carbide grades

Note:

The insert form must correspond to the holder form. E.g.: Form A Toolholder = Form A Insert

Ordering note:

For Dimensions of Groove DIN please see Technical Instructions.

Insert

S117

Tolerance grade H9

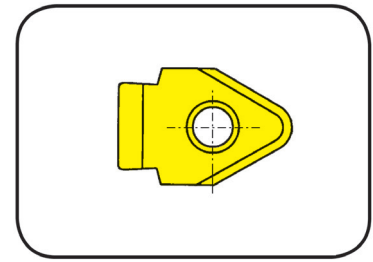

Bore Ø from	.551"
Depth of groove	.268"

Recommended for: conventional broaching

for Toolholder

Type SH117
SHU117
SHM117
SHMU117
H117

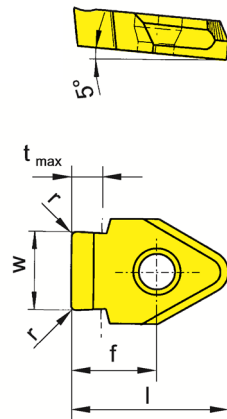

Keyways according to
DIN6885

Part number	w	l	r	D _{min}	t _{max}	f	Form	AN45
S117.0302.01.08.B1	.119	.512	.005	.551	.079	.236	G	▲
S117.0402.01.08.B1	.158	.512	.005	.551	.087	.236	F	▲
S117.0502.02.08.B1	.198	.512	.008	.551	.114	.236	F	▲
S117.0502.02.10.B1	.198	.571	.008	.669	.110	.256	A	▲
S117.0602.02.10.B1	.237	.571	.008	.669	.138	.256	A	▲
S117.0803.02.10.B1	.316	.630	.008	.866	.169	.315	B	▲
S117.1003.03.14.B1	.395	.815	.012	1.181	.173	.441	C	▲
S117.1203.03.14.B1	.474	.815	.012	1.496	.232	.441	D	▲
S117.1403.03.16.B1	.553	.815	.012	1.575	.268	.441	E	▲
S117.1603.03.18.B1	.631	1.142	.012	1.575	.268	.614	H	▲
S117.1803.03.20.B1	.710	1.142	.012	1.969	.307	.614	I	▲
S117.2004.05.20.B1	.789	1.142	.02	1.969	.307	.614	I	▲

▲ on stock Δ 4 weeks x upon request

- recommended
- alternative recommendation
- not suitable

- uncoated grades
- coated grades
- brazed/Cermet

Dimensions in inch

P	●
M	○
K	●
N	●
S	○
H	-

Carbide grades

Note:

The insert form must correspond to the holder form. E.g.: Form A Toolholder = Form A Insert

Ordering note:

For Dimensions of Groove DIN please see Technical Instructions.



Insert

S117

Tolerance grade P9

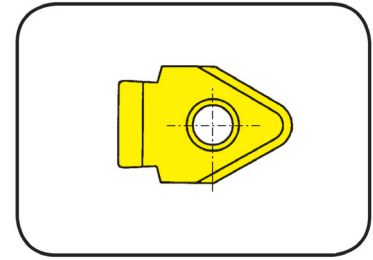

Bore Ø from	.551"
Depth of groove up to	.268"

Recommended for: conventional broaching

for Toolholder

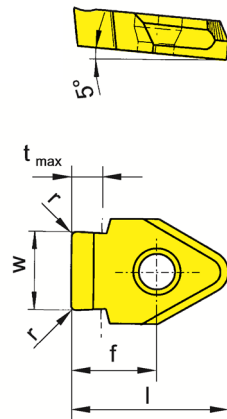

Type SH117
SHU117
SHM117
SHMU117
H117

Keyways according to
DIN6885

Part number	w	l	r	D _{min}	t _{max}	f	Form	AN45
S117.0298.01.08.B1	.118	.512	.005	.551	.079	.236	G	▲
S117.0397.01.08.B1	.157	.512	.005	.551	.087	.236	F	▲
S117.0497.02.08.B1	.196	.512	.008	.551	.114	.236	F	▲
S117.0497.02.10.B1	.196	.571	.008	.669	.110	.256	A	▲
S117.0597.02.10.B1	.235	.571	.008	.669	.138	.256	A	▲
S117.0796.02.10.B1	.314	.630	.008	.866	.169	.315	B	▲
S117.0996.03.14.B1	.393	.815	.012	1.181	.173	.441	C	▲
S117.1196.03.14.B1	.471	.815	.012	1.496	.232	.441	D	▲
S117.1396.03.16.B1	.550	.815	.012	1.575	.268	.441	E	▲
S117.1597.03.18.B1	.629	1.142	.012	1.575	.268	.614	H	▲
S117.1797.03.20.B1	.707	1.142	.012	1.969	.307	.614	I	▲
S117.1997.05.20.B1	.786	1.142	.02	1.969	.307	.614	I	▲

▲ on stock Δ 4 weeks x upon request

- recommended
- alternative recommendation
- not suitable

- uncoated grades
- coated grades
- brazed/Cermet

Dimensions in inch

P	●
M	○
K	●
N	●
S	○
H	-

Carbide grades

Note:

The insert form must correspond to the holder form. E.g.: Form A Toolholder = Form A Insert

Ordering note:

For Dimensions of Groove DIN please see Technical Instructions.

Insert

S117

Tolerance grade JS9

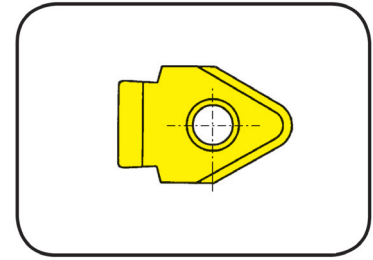

Bore Ø from	.551"
Depth of groove up to	.335"

Recommended for: conventional broaching

for Toolholder

Type SH117
SHU117
SHM117
SHMU117
H117

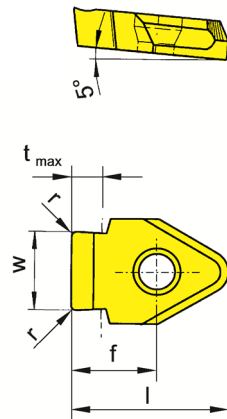

Keyways according to
DIN6885

Part number	w	l	r	D _{min}	t _{max}	f	Form	AN45
S117.0300.01.08.B1	.119	.512	.005	.551	.079	.236	G	▲
S117.0400.01.08.B1	.158	.512	.005	.551	.087	.236	F	▲
S117.0500.02.08.B1	.197	.512	.008	.551	.114	.236	F	▲
S117.0500.02.10.B1	.197	.571	.008	.669	.110	.256	A	▲
S117.0600.02.10.B1	.237	.571	.008	.669	.138	.256	A	▲
S117.0800.02.10.B1	.315	.630	.008	.866	.169	.315	B	▲
S117.1000.03.14.B1	.394	.815	.012	1.181	.173	.441	C	▲
S117.1200.03.14.B1	.473	.815	.012	1.496	.232	.441	D	▲
S117.1200.05.14.B1	.472	.815	.020	1.496	.335	.441	D	▲
S117.1400.03.16.B1	.552	.815	.012	1.575	.268	.441	E	▲
S117.1601.03.18.B1	.630	1.142	.012	1.575	.268	.614	H	▲
S117.1801.03.20.B1	.709	1.142	.012	1.969	.307	.614	I	▲
S117.2002.05.20.B1	.788	1.142	.02	1.969	.307	.614	I	▲

▲ on stock Δ 4 weeks x upon request

- recommended
- alternative recommendation
- not suitable

- uncoated grades
- coated grades
- brazed/Cermet

Dimensions in inch

P	●
M	○
K	●
N	●
S	○
H	-

Carbide grades

Note:

Insert S117.1200.05.14 = Nw from .472"

Ordering note:

For Dimensions of Groove DIN please see Technical Instructions.



Insert

S117

Bore Ø from .551"

Recommended for: conventional broaching

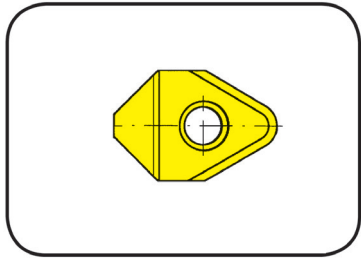

for Toolholder

Type SH117
SHU117
SHM117
SHMU117
H117

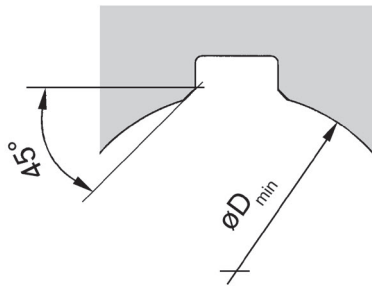
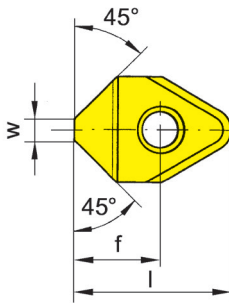
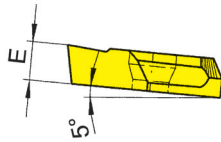

Chamfering

Part number	w	l	D _{min}	f	Form	AN45
S117.1545.10.B2	.059	.630	.669	.315	A	▲
S117.2445.08.B2	.094	.512	.551	.236	F	▲
S117.3045.10.B2	.118	.630	.866	.315	B	▲
S117.6045.14.B2	.236	.827	1.181	.441	C/D	▲

▲ on stock Δ 4 weeks x upon request

● recommended
○ alternative recommendation
- not suitable

□ uncoated grades
■ coated grades
■ brazed/Cermet

Dimensions in inch

P	●
M	○
K	●
N	●
S	○
H	-

Carbide grades

Note:

The insert form must correspond to the holder form. E.g.: Form A Toolholder = Form A Insert

X

Insert

S117

Hexagon socket SW = .551 - 1.417"

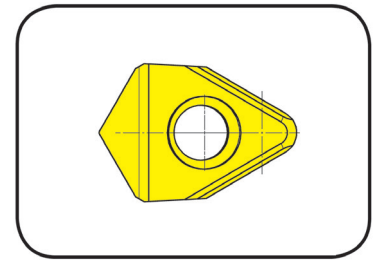

Recommended for: conventional broaching

for Toolholder

Type SH117
SHU117
SHM117
SHMU117
H117

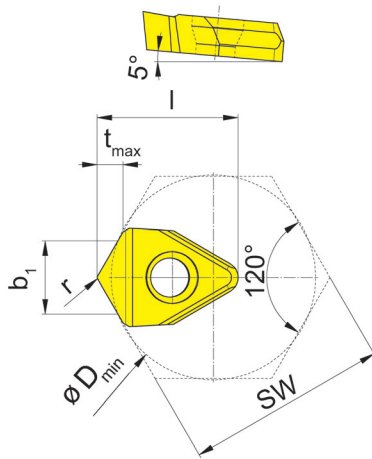

Hexagon socket

Part number	SW	b ₁	l	r	D _{min}	t _{max}	Toolholder	AN45
S117.SW14.08.B2	.551 - .630	.194 - .228	.512	.008	.559 - .638	.075	SH117.1425.30.1.08	▲
S117.SW16.10.B2	.630 - .866	.228 - .332	.551	.008	.638 - .874	.098	SH117.1625.30.1.10	▲
S117.SW24.12.B2	.945 - 1.063	.343 - .394	.669	.012	.957 - 1.075	.118	SH117.2432.30.1.12	▲
S117.SW30.16.B2	1.181 - 1.417	.446 - .550	.815	.012	1.193 - 1.429	.165	SH117.3032.30.1.16	▲

▲ on stock Δ 4 weeks x upon request

● recommended
○ alternative recommendation
- not suitable

□ uncoated grades
■ coated grades
■ brazed/Cermet

Dimensions in inch

P	●
M	○
K	●
N	●
S	○
H	-

Carbide grades



Insert

S117

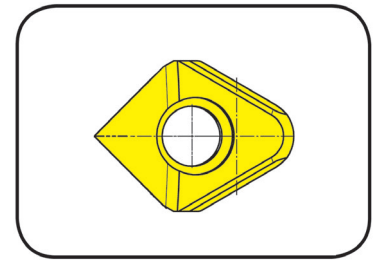

Square Broaching from SW = 13

Recommended for: broaching units

for Toolholder

Type SH117.SQ...
SHU117.SQ...

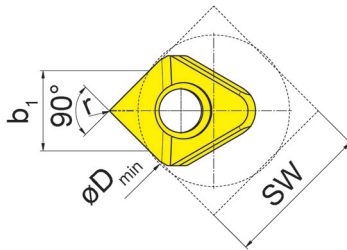
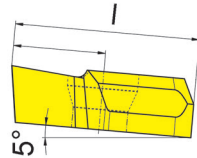

Square Broaching

Part number	SW	b ₁	l	r	D _{min}	Toolholder	AN45
S117.SQ.1315.08.A1	.512 - .591	.260 - .309	.512	.008	.531	SHU117/SH117.13..SQ...	▲
S117.SQ.1517.10.A1	.591 - .669	.309 - .357	.583	.008	.610	SHU117/SH117.15..SQ...	▲
S117.SQ.1719.12.A1	.669 - .748	.357 - .407	.657	.008	.689	SHU117/SH117.17..SQ...	▲
S117.SQ.1922.16.A1	.748 - .866	.407 - .481	.748	.008	.768	SHU117/SH117.19..SQ...	▲

▲ on stock Δ 4 weeks x upon request

● recommended
o alternative recommendation
- not suitable

□ uncoated grades
■ coated grades
■ brazed/Cermet

Dimensions in inch

P	●
M	o
K	●
N	●
S	o
H	-

Carbide grades



Insert

S117

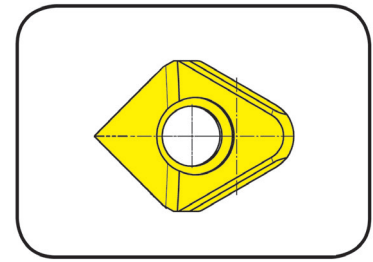

Square Broaching from SW = 4

Recommended for: conventional broaching

for Toolholder

Type SH117.SQ...
SHU117.SQ...

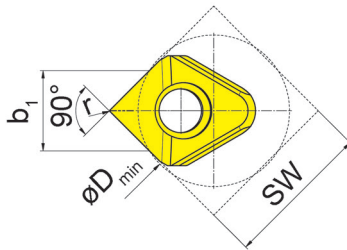
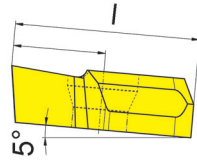

Square Broaching

Part number	SW	b ₁	l	r	D _{min}	Toolholder	AN45
S117.SQ.1315.08.B2	.512 - .591	.260 - .309	.512	.008	.531	SHU117/SH117.13..SQ...	▲
S117.SQ.1517.10.B2	.591 - .669	.309 - .357	.583	.008	.610	SHU117/SH117.15..SQ...	▲
S117.SQ.1719.12.B2	.669 - .748	.357 - .407	.657	.008	.689	SHU117/SH117.17..SQ...	▲
S117.SQ.1922.16.B2	.748 - .866	.407 - .481	.748	.008	.768	SHU117/SH117.19..SQ...	▲

▲ on stock Δ 4 weeks x upon request

● recommended
○ alternative recommendation
- not suitable

□ uncoated grades
■ coated grades
■ brazed/Cermet

Dimensions in inch

P	●
M	○
K	●
N	●
S	○
H	-

Carbide grades



Application Tips:

- It is important to use a machine with mechanical spindle lock.
- The use of proper coolant is key to a good surface finish, long tool life, and chip evacuation.
- A relief groove or the possibility for a ramp down exit out of the cut is necessary at the end of the broached groove.
- Setting of the tool is very important. Double check the component diameter before taking the first pass.
- The tool should be set at the 12 o'clock position to ensure that chips fall away from the groove.
- Take an accurate measurement of the insert and program the dimension into the machine tool parameter.
- Position the tool at the start position of the first stroke and program a stop to perform a visual check to assure a collision free first pass of the tool.

Machining example:

Bore diameter 32 mm, groove width 8 mm:
At a radius of 16 mm and with a clearance of 0.2 mm for safety at the r 0.2 mm corner radii, the tool has to be set at 15.292 mm in X-axis to avoid any collision at the beginning of the process.

Parameters:

Bore diameter = 32 mm
Security Distance = 0.2 mm
Groove width = 8 mm
c = Bore radius = 16 mm
a = Groove width x 0.5 = 4 mm

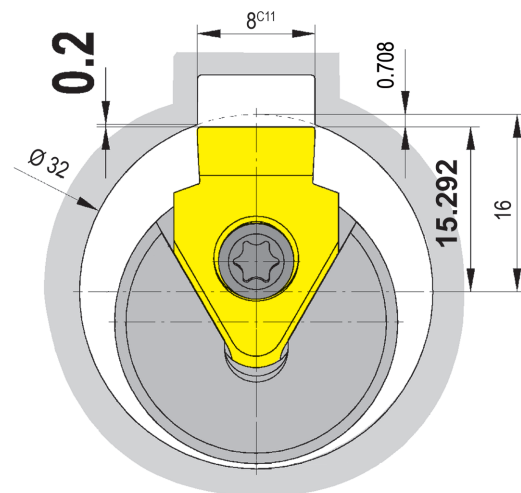

Calculation of the start position b_1 :

$$b = \sqrt{c^2 - a^2}$$

$$b = \sqrt{16^2 - 4^2}$$

$$b = 15.491933$$

$b_1 = b$ - Clearance distance

$$b_1 = 15.492 - 0.2 = 15.292 \text{ mm}$$

→ **Start position = Ø 30.584 mm**

or

Calculate total segment height h

w = Cutting width = 8 mm

r = Bore diameter x 0.5 = 16 mm

$$h = \text{Security Distance} + (r - \sqrt{r^2 - (w \times 0.5)^2})$$

$$h = 0.2 + (16 - \sqrt{16^2 - 4^2})$$

$$h = 0.708 \text{ mm}$$

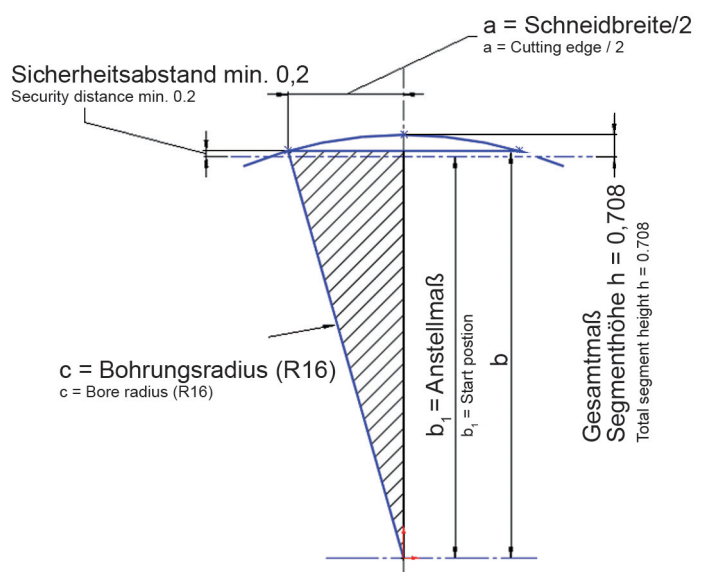

X

Torque of Screws

Toolholder	Screw	Torque M_d Nm	Clamping Wrench	Blade
SB105	6.075T15P	5.0	T15PQ	DT15PQ
SB110	6.075T15P	5.0	T15PQ	DT15PQ
SH117...08	030.3509.T15P	3.5	T15PQ	DT15PK
SH117...10/...12	4.09T15P	5.0	T15PQ	DT15PK
SH117...16	5.12T20P	6.5	T20PQ	DT20PK/DT20PQ
SHM117...08	030.3509.T15P	3.5	T15PQ	DT15PK

Summary SB105/SB110 - Holder can be located directly in the the turret or m/c spindle

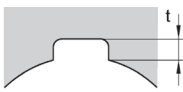
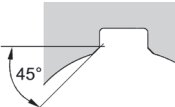
Dimensions DIN				Broaching 			Chamfering 		
Width	Tolerance Grade	D_{min}	t	Inserts N105...A2/...B1	l_2	Toolholder	Inserts N105...A1.../B1	Toolholder	
2	C11	8	1.0	N105.0210.2.08	12				
3	C11	10	1.8	N105.0310.2.10	12	SB105.0020.1.01		SB105.0020.1.01	
3	C11	13	1.8	N105.0310.2.13	12	SB105.0025.1.01	N105.4545.2.6	SB105.0025.1.01	
4	C11	16	2.0	N105.0410.2.16	12				
4	C11	16	2.0	N110.0202.05.04	25	SB110.0025.1.02	N110.4545.4.9	SB110.0025.1.02	
4	C11	16	2.0	N110.0410.05.07	40	SB110.0032.1.02	N110.4545.7.9	SB110.0032.1.02	
5	C11	-	-	N110.0510.05.04	25	SB110.0025.1.02	N110.4545.4.9	SB110.0025.1.02	
5	C11	-	-	N110.0510.05.07	40	SB110.0032.1.02	N110.4545.7.9	SB110.0032.1.02	
2	H9	6	1.1	N105.0202.01.01	12		N105.4545.2.6	SB105.0020.1.01	
3	H9	8	1.5	N105.0302.01.01	12	SB105.0020.1.01		SB105.0020.1.01	
4	H9	10	1.9	N105.0402.01.01	15	SB105.0025.1.01	N105.4545.3.6	SB105.0025.1.01	
4	H9	10	1.9	N110.0402.02.04	25		N110.4545.4.9	SB110.0025.1.02	
4	H9	10	1.9	N110.0402.02.07	40	SB110.0025.1.02	N110.4545.7.9	SB110.0025.1.02	
5	H9	12	2.4	N110.0502.02.04	25	SB110.0032.1.02	N110.4545.4.9	SB110.0032.1.02	
5	H9	12	2.4	N110.0502.02.07	40		N110.4545.7.9	SB110.0032.1.02	
2	P9	6	1.1	N105.0198.01.01	12		N105.4545.2.6	SB105.0020.1.01	
3	P9	8	1.5	N105.0298.01.01	12	SB105.0020.1.01		SB105.0020.1.01	
4	P9	10	1.9	N105.0397.01.01	15	SB105.0025.1.01	N105.4545.3.6	SB105.0025.1.01	
4	P9	10	1.9	N110.0397.02.04	25		N110.4545.4.9	SB110.0025.1.02	
4	P9	10	1.9	N110.0397.02.07	40	SB110.0025.1.02	N110.4545.7.9	SB110.0025.1.02	
5	P9	12	2.4	N110.0497.02.04	25	SB110.0032.1.02	N110.4545.4.9	SB110.0032.1.02	
5	P9	12	2.4	N110.0497.02.07	40		N110.4545.7.9	SB110.0032.1.02	
2	JS9	6	1.1	N105.0200.01.01	12		N105.4545.2.6	SB105.0020.1.01	
3	JS9	8	1.5	N105.0300.01.01	12	SB105.0020.1.01		SB105.0020.1.01	
4	JS9	10	1.9	N105.0400.01.01	15	SB105.0025.1.01	N105.4545.2.6	SB105.0025.1.01	
4	JS9	10	1.9	N105.0400.02.01	15		N105.4545.3.6	SB105.0025.1.01	
4	JS9	10	1.9	N110.0400.02.04	25		N110.4545.4.9	SB110.0025.1.02	
4	JS9	10	1.9	N110.0400.02.07	40	SB110.0025.1.02	N110.4545.7.9	SB110.0025.1.02	
5	JS9	12	2.4	N110.0500.02.04	25	SB110.0032.1.02	N110.4545.4.9	SB110.0032.1.02	
5	JS9	12	2.4	N110.0500.02.07	40		N110.4545.7.9	SB110.0032.1.02	

X

Summary SH117/SHM117 - Holder can be located directly in the turret or m/c spindle

Dimensions DIN

Broaching

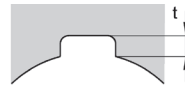

Width	Tolerance Grade	D _{min}	t	Inserts S117...A1/...B1	w	Toolholder	Tool length l ₂		
							.1.	.2.	.3.
3	C11	14	2.0	S117.0310.04.08	3.1	SH117.1425.1.3.08	20		
4		14	2.1	S117.0412.05.08	4.12	SH/SHM117...08	30	40	55
6		22	2.6	S117.0612.09.10	6.12	SH117.0025...10	50	70	-
7		27	3.3	S117.0713.11.10	7.13	SH117.0025...10	50	70	-
8		32	3.4	S117.0813.11.10	8.13	SH117.0025...10	50	70	-
10		40	4.2	S117.1013.11.14	10.13	SH117.0032...16	50	75	100
12		50	5.1	S117.1215.14.14	12.15	SH117.0032...16	50	75	100
16		70	6.6	S117.1215.18.14	12.15	SH117.0032...16	50	75	100
24		100	8.5	S117.1215.23.14	12.15	SH117.0032...16	50	75	100
3	H9	14	2.0	S117.0302.01.08	3.018	SH117.1425.1.3.08	20	-	-
4		14	2.1	S117.0402.01.08	4.022	SH/SHM117...08	30	40	55
5		14	2.7	S117.0502.02.08	5.022	SH/SHM117...08	30	40	55
5		17	2.7	S117.0502.02.10	5.022	SH117.1725...10	40	55	-
6		17	3.4	S117.0602.02.10	6.022	SH117.1725...10	40	55	-
8		22	4.1	S117.0803.02.10	8.028	SH117.0025...10	50	70	-
10		30	4.2	S117.1003.03.14	10.028	SH117.3032...16	50	75	100
12		38	5.7	S117.1203.03.14	12.036	SH117.0032...16	50	75	100
14		40	6.8	S117.1403.03.16	14.036	SH117.4032...16	50	75	100
3	P9	14	2.0	S117.0298.01.08	2.99	SH117.1425.1.3.08	20		
4		14	2.1	S117.0397.01.08	3.98	SH/SHM117...08	30	40	55
5		14	2.7	S117.0497.02.08	4.98	SH/SHM117...08	30	40	55
5		17	2.7	S117.0497.02.10	4.98	SH117.1725...10	40	55	-
6		17	3.4	S117.0597.02.10	5.98	SH117.1725...10	40	55	-
8		22	4.1	S117.0796.02.10	7.98	SH117.0025...10	50	70	-
10		30	4.2	S117.0996.03.14	9.98	SH117.3032...16	50	75	100
12		38	5.7	S117.1196.03.14	11.97	SH117.0032...16	50	75	100
14		40	6.8	S117.1396.03.16	13.97	SH117.4032...16	50	75	100
3	JS9	14	2.0	S117.0300.01.08	3.01	SH117.1425.1.3.08	20		
4		14	2.1	S117.0400.01.08	4.01	SH/SHM117...08	30	40	55
5		14	2.7	S117.0500.02.08	5.01	SH/SHM117...08	30	40	55
5		17	2.7	S117.0500.02.10	5.01	SH117.1725...10	40	55	-
6		17	3.4	S117.0600.02.10	6.01	SH117.1725...10	40	55	-
8		22	4.1	S117.0800.02.10	8.01	SH117.0025...10	50	70	-
10		30	4.2	S117.1000.03.14	10.01	SH117.3032...16	50	75	100
12		38	5.7	S117.1200.03.14	12.01	SH117.0032...16	50	75	100
14		40	6.8	S117.1400.03.16	14.01	SH117.4032...16	50	75	100

X

Summary SH117/SHM117 - Holder can be located directly in the turret or m/c spindle

Dimensions DIN

Chamfering

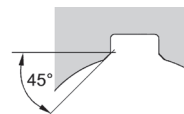

Width	Tolerance Class	D _{min}	Inserts S117...A1/...B1	Toolholder	Tool Length l ₂		
					.1.	.2.	.3.
3	C11	14	S117.2445.08	SH/SHM117...08	20/30	40	55
4		14	S117.2445.08	SH/SHM117...08	20/30	40	55
6		22	S117.3045.10	SH117.0025...10	50	70	
7		27	S117.3045.10	SH117.0025...10	50	70	
8		32	S117.3045.10	SH117.0025...10	50	70	
10		40	S117.6045.14	SH117.0032...16	50	75	100
12		50	S117.6045.14	SH117.0032...16	50	75	100
16		70	S117.6045.14	SH117.0032...16	50	75	100
24		100	S117.6045.14	SH117.0032...16	50	75	100
3	H9	14	S117.2445.08	SH/SHM117...08	20/30		
4		14	S117.2445.08	SH/SHM117...08	20/30		
5		14	S117.2445.08	SH/SHM117...08	20/30		
5		17	S117.1545.10	SH117.1725...10	40	55	
6		17	S117.1545.10	SH117.1725...10	40	55	
8		22	S117.3045.10	SH117.0025...10	50	70	
10		30	S117.6045.14	SH117.3032...16	50	75	100
12		38	S117.6045.14	SH117.0032...16	50	75	100
14		40	S117.6045.14	SH117.0032...16	50	75	100
3	P9	14	S117.2445.08	SH/SHM117...08	20/30		
4		14	S117.2445.08	SH/SHM117...08	20/30		
5		14	S117.2445.08	SH/SHM117...08	20/30		
5		17	S117.1545.10	SH117.1725...10	40	55	
6		17	S117.1545.10	SH117.1725...10	40	55	
8		22	S117.3045.10	SH117.0025...10	50	70	
10		30	S117.6045.14	SH117.3032...16	50	75	100
12		38	S117.6045.14	SH117.0032...16	50	75	100
14		40	S117.6045.14	SH117.0032...16	50	75	100
3	JS9	14	S117.2445.08	SH/SHM117...08	20/30		
4		14	S117.2445.08	SH/SHM117...08	20/30		
5		14	S117.2445.08	SH/SHM117...08	20/30		
5		17	S117.1545.10	SH117.1725...10	40	55	
6		17	S117.1545.10	SH117.1725...10	40	55	
8		22	S117.3045.10	SH117.0025...10	50	70	
10		30	S117.6045.14	SH117.3032...16	50	75	100
12		38	S117.6045.14	SH117.0032...16	50	75	100
12		38	S117.6045.14	SH117.0032...16	50	75	100
14	40	S117.6045.14	SH117.0032...16	50	75	100	



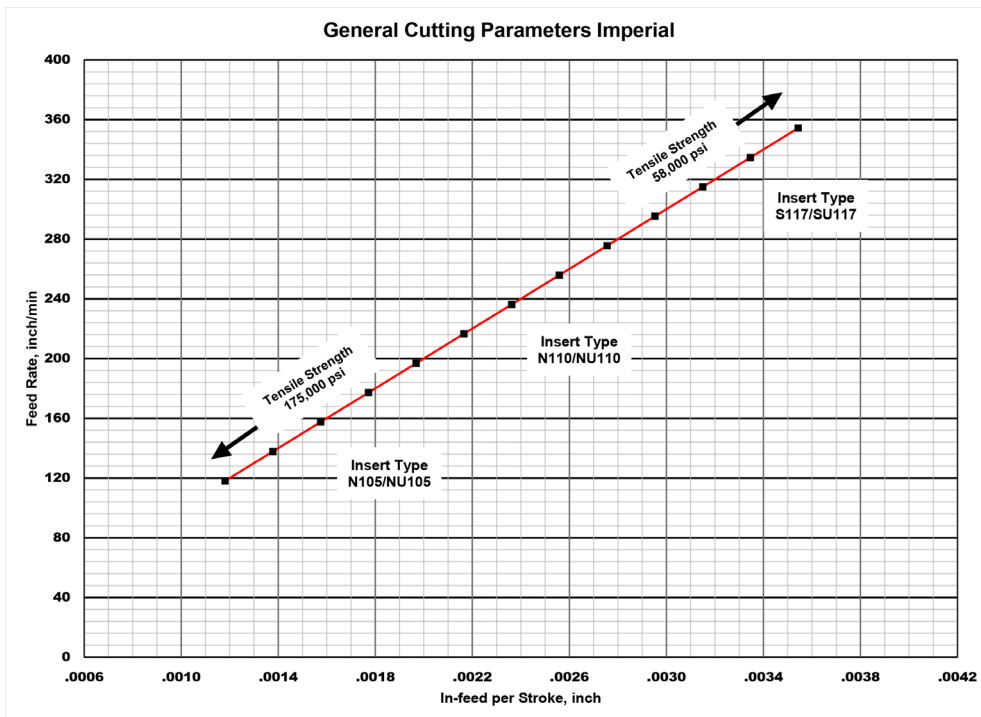
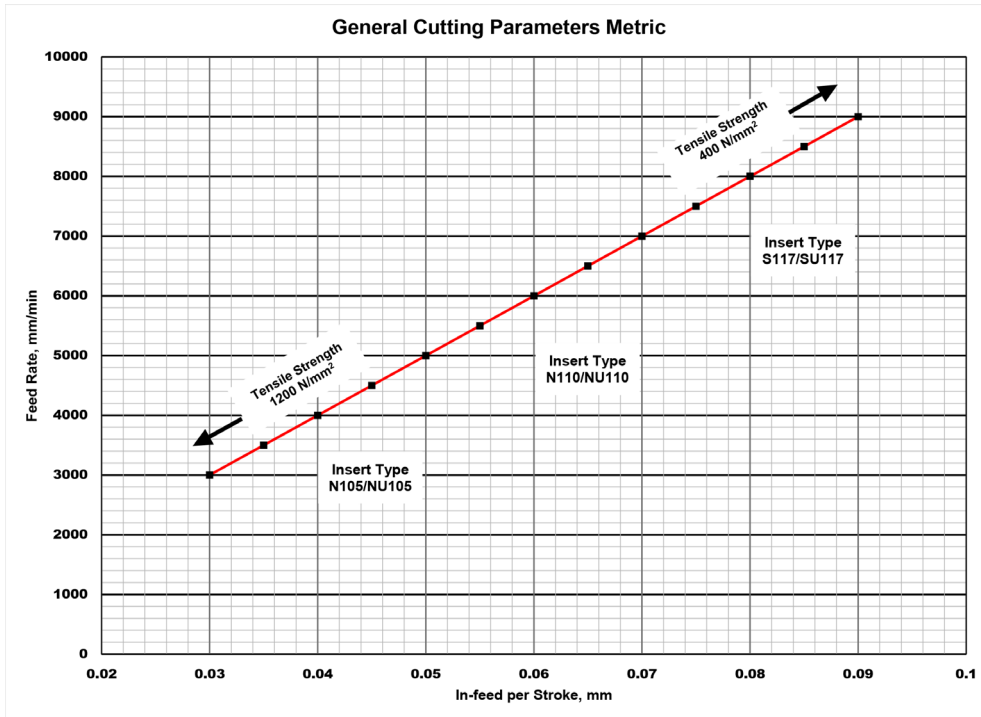

The above values are guidelines only. The physical condition of the machine, the work piece profile and clamping, as well as the type of material have great influence on the depth of cut and feed rate.

Application Tips:

- A relief groove or the possibility for a 'ramp down' exit out of the groove is necessary at the end of the broached groove.
- The insert cutting edge has to be positioned outside the groove before retracting the tool.
- Take an accurate measurement of the insert and program the dimension into the machine tool parameter.
- Position the tool at the start position of the first stroke and program a stop to perform a visual check to assure a collision free first pass of the tool.
- The use of proper coolant is key to a good surface finish, long tool life as well as chip evacuation out of a blind hole.

Example for broaching on SIEMENS Control Machines with lockable Spindle

NC - Programme

N.....(BROACHING)	Sequence Number and Application
T..... M5 LF	Tool callout, Spindle Stop
M..... LF	Brake ON
G94 LF	Feed Rate in mm/min
R1 = 30.584 LF	choose Parameter for start Ø
M8 LF	Coolant ON
N100 LF	Sequence Number for repetition START
G0 X = R1 Z5 LF	Start position in X and Z in front of part
G1 Z-25 F8000 LF	Linear move in Z at feed rate of 8000 mm/min
G0 X30.584	Rapid move in X to start Ø i.e. drop down position
G0 Z5	Rapid move in Z to start position.
R1 = R1+0.16	As Ø programming is in effect the depth of cut must be doubled (Depth of Cut is 0.08 mm)
N200	Sequence Number of repetition END.
.....LF	Repetition Cycle with Sequence Number from START to END and Number of repetitions

Example:

- Groove according to table in bore **Ø 32 mm**
- Groove width **8^{c11}**
- Depth of Cut per Stroke 0.08 mm
- The **Number of Strokes** resulted out of complete cutting depth from start position to the bottom of the groove divided by depth of cut per stroke
- This Value must then be multiplied by 2 (because Ø Programming) and Value is programmed as the Number of Strokes in the NC-Programme.

Calculation:

- Starting Position = Security Distance + Distance from Ø 32 mm to Cutting Edge (see Example on Page X68) equals a segment height of **0.508 mm** + Security Distance of **0.20 mm** to a total of **0.708 mm**.
- Starting Position = **30.584 mm** (32 - [0.708 x 2] = 30.584 mm).
- The groove depth of **2.90 mm** added to the **0.708 mm** = **3.608 mm**.
- This is the dimension from the starting position to the bottom of the groove and in order to program this on the Ø, the **3.608 mm** dimension must be **multiplied by 2** which will equal the sum of **7.216 mm**.
- When the **7.216 mm** is divided by (**2 x 0.08 mm**) = **0.16 mm** depth per stroke the Result will be **45.1 Strokes** and therefore **45 total Strokes** are programmed.

The remainder of 0.1 Strokes to achieve the finish dimension must be programmed using the fine correction.

X

Example for broaching on a TRAUB TNA 400 with C-Axis

NC - Programme

N.....(BROACHING)	Sequence Number and Application
G97 T..... M5	constant RPM, Tool callout, Spindle Stop
M17	C - axis ON
G94	Feed Rate in mm/min
L1 = 30.584	choose Parameter for start Ø
M8 M19	Coolant ON, Spindle Break ON
N100	Sequence Number for repetition START
G0 XL1 Z5	Start position in X and Z in front of part
G1 Z-25 F8000	Linear move in Z at feed rate of 8000 mm/min
G0 X30.584	Rapid move in X to start Ø i.e. drop down position
G0 Z5	Rapid move in Z to start position.
L1 = L1+0.16	As Ø programming is in effect the depth of cut must be doubled (Depth of Cut is 0.08 mm)
N200	Sequence Number of repetition END.
G22 P100 Q200 H45	Repetition Cycle with Sequence Number from START to END and Number of repetitions

Example:

- Groove according to table in bore **Ø 32 mm**
- Groove width **8^{c11}**
- Depth of Cut per Stroke 0.08 mm
- The **Number of Strokes** resulted out of complete cutting depth from start position to the bottom of the groove divided by depth of cut per stroke
- This value must then be multiplied by 2 (because Ø Programming) and Value is programmed as the Number of Strokes in the NC-Programme.

Calculation:

- Starting Position = Security Distance + Distance from Ø 32 mm to Cutting Edge (see Example on Page X68) equals a segment height of **0.508 mm** + Security Distance of **0.20 mm** to a total of **0.708 mm**.
- Starting Position = **30.584 mm** (32 - [0.708 x 2] = 30.584 mm).
- The groove depth of **2.90 mm** added to the **0.708 mm** = **3.608 mm**.
- This is the dimension from the starting position to the bottom of the groove and in order to program this on the Ø, the **3.608 mm** dimension must be **multiplied by 2** which will equal the sum of **7.216 mm**.
- When the **7.216 mm** is divided by (**2 x 0.08 mm**) = **0.16 mm** depth per stroke the Result will be **45.1 Strokes** and therefore **45 total Strokes** are programmed.

The remainder of 0.1 Strokes to achieve the finish dimension must be programmed using the fine correction.

Attention: The true depth of cut for the insert will be 0.08 mm.

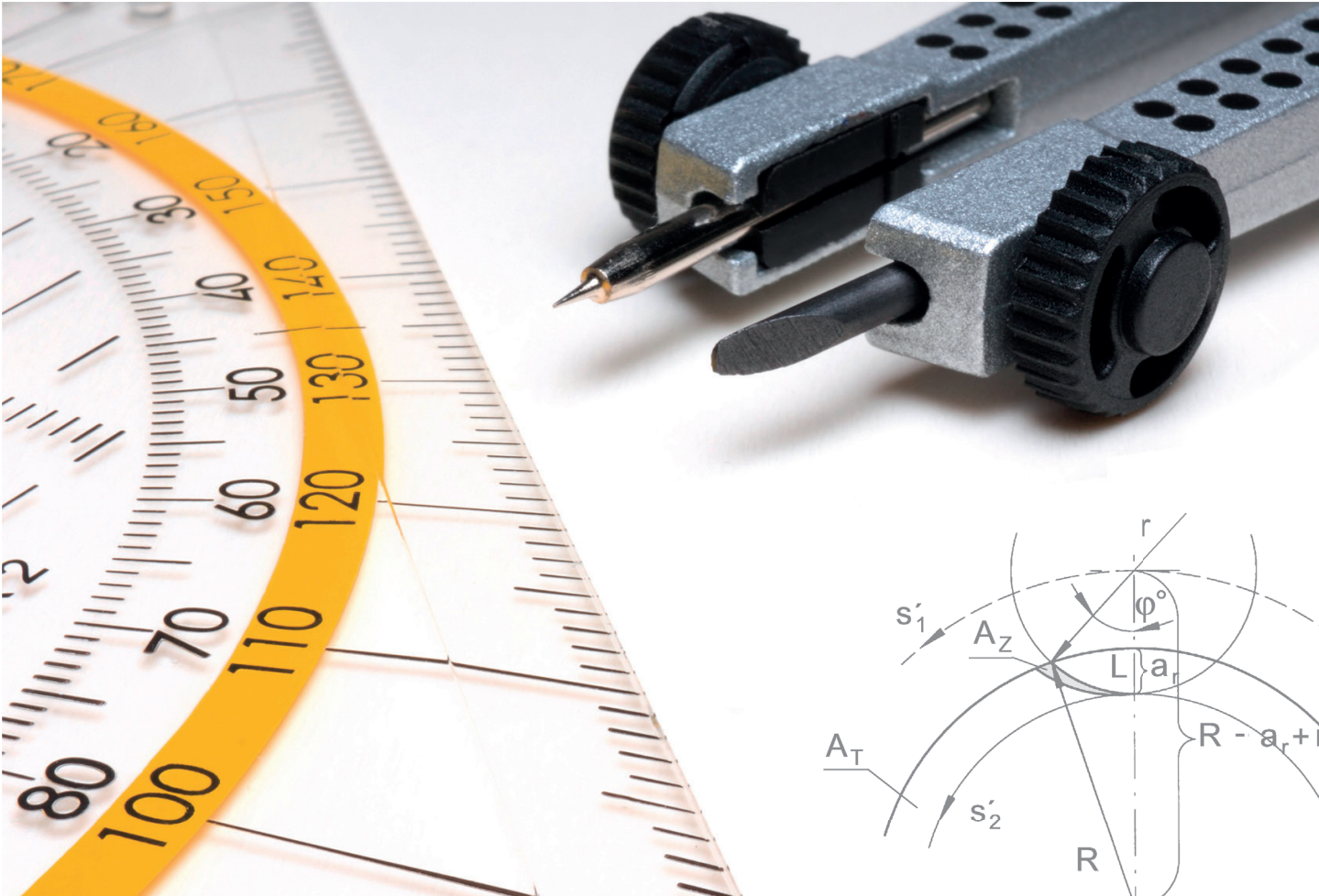

Summary

Page

Additional Equipment

Y2-Y8

Y

With the mobile high-pressure systems from **GRAF** you can employ the through cooled tools optimally.

The advantages are obvious: longer tool life!



Standard connection for coolant supply for pipe Ø 6 mm

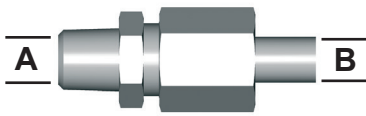

Connection for coolant supply straight screwed

A	B	Part Number
M8 x 1	ø 6 mm	004.00.19
G1/8"	ø 6 mm	004.00.14

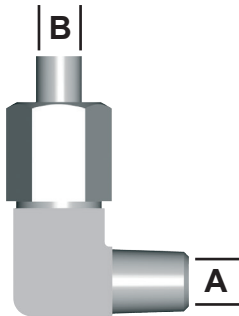

Connection for coolant supply angled and fix

A	B	Part Number
M8 x 1	ø 6 mm	004.00.22
G1/8"	ø 6 mm	004.00.33

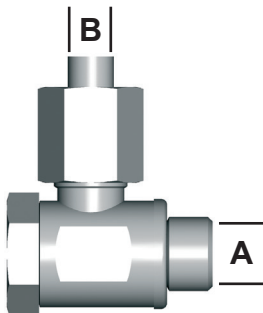

Swivelling screw-fitting

A	B	Part Number
M8 x 1	ø 6 mm	004.00.61
G1/8"	ø 6 mm	004.00.16

Click connection for coolant supply

Quick connector

M10 x 1 - 004.00.49

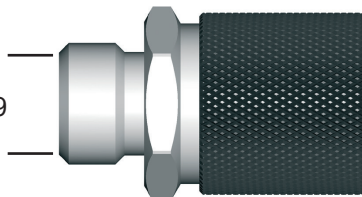

Plug

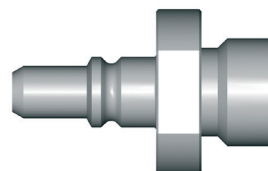

M8 x 1 - 004.00.56
G1/8" - 004.00.57

Plug

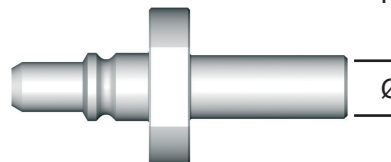

Ø 6 mm - 004.00.59



D 041 VL
0.4-1 Nm

Torque screw driver with scale
- variable torque setting
- adjusted torque is shown on display

The Torque can be adjusted with a special torque setter (included).

Ergonomical form gives perfect handling abilities. Audible signal when set torque is reached.

(Standard: EN ISO 6798, BS EN 26789, ASME B 107.14.M.)

(Precision: $\pm 6 \%$)



D 15 VL
1-5 Nm



D 28 VL
2-7 Nm



ED 28 VL
for
D041VL / D15VL / D28VL

Device for setting the required torque.

Handle: Cellulose acetate with micro structured surface

Blade: Octagonal (8 flats) blade, hardened galvanized



DT6PK
DT7PK
DT8PK
DT9PK
DT10PK
DT15PK
DT20PK
DT25PK

for
D041VL / D15VL / D28VL



Plus

Blade for TORX-Plus® screws

Blade: High quality Chrome-Vanadium steel, through hardened,chrome plated.

Wiha Chrome Blade guarantees maximum precision.

Colored code dark green

Utilization: Controlled screw setting with definite torque in combination with Wiha torque screw driver handle.



DT6K
DT8K
DT15K

for
D041VL / D15VL / D28VL



Blade for Torx screws

Blade: High quality Chrome-Vanadium steel, through hardened,chrome plated.

Wiha Chrome Blade guarantees maximum precision.

Colored code dark green

Utilization: Controlled screw setting with definite torque in combination with Wiha torque screw driver handle.



DSW15K
DSW20K
DSW25K
DSW30K
DSW40K

for
D041VL / D15VL / D28VL

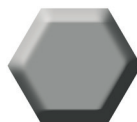

Blade for allen screws

Blade: High quality Chrome-Vanadium steel, through hardened,chrome plated.

Wiha Chrome Blade guarantees maximum precision.

Colored code red

Utilization: Controlled screw setting with definite torque in combination with Wiha torque screw driver handle

DSW50K
DSW60K

for
D15QL



D14ZBK

for
D041VL / D15VL / D28VL

Universal Bitholder for C6.3 and E6.3 (1/4") Bits

Blade: High quality Chrome-Vanadium steel, through hardened, chrome plated.

Collar: Stainless steel

Utilization: For controlled screw setting with definite torque in combination with torque screw driver handle.



D515QL

5-14 Nm

Torque screw driver with scale

- variable torque setting

- adjusted torque is shown on display

The Torque can be adjusted with a special torque setter (included).

Ergonomical form gives perfect handling abilities. Audible signal when set torque is reached.

(Standard: EN ISO 6798, BS EN 26789, ASME B 107.14.M.)

(Precision: $\pm 6\%$)



ED515QL

for
D515QL

Device for setting the required torque.

Handle: Cellulose acetate with micro structured surface

Blade: Octagonal (8 flats) blade, hardened galvanized



DT15PQ
DT20PQ
DT25PQ
DT27PQ
DT30PQ

for
D515QL



Plus

Blade for TORX-Plus® screws

Blade: High quality Chrome-Vanadium steel, through hardened, chrome plated.
 Wiha Chrome Blade guarantees maximum precision.

Colored code dark green

Utilization: Controlled screw setting with definite torque in combination with Wiha torque screw driver handle.



D14ZBQ

for
D515QL

Universal Bitholder for C6.3 and E6.3 (1/4") Bits

Blade: High quality Chrome-Vanadium steel, through hardened, chrome plated.

Collar: Stainless steel

Utilization: For controlled screw setting with definite torque in combination with torque screw driver handle.



14ZQK

Universal Bitholder with T-handle for C6.3 and E6.3 (1/4") Bits

Blade: High quality Chrome-Vanadium steel, through hardened, chrome plated.

Collar: Stainless steel

Utilization: For controlled opening



- T6PW
- T7PW
- T8PW
- T9PW
- T10PW
- T15PW
- T20PW
- T25PW
- T30PW



Plus

Wrench for TORX PLUS® Screws

Utilization: For all kind of using TORX PLUS® Screws

Attention: TORX PLUS®-Wrench does NOT fit standard Torx-Screws

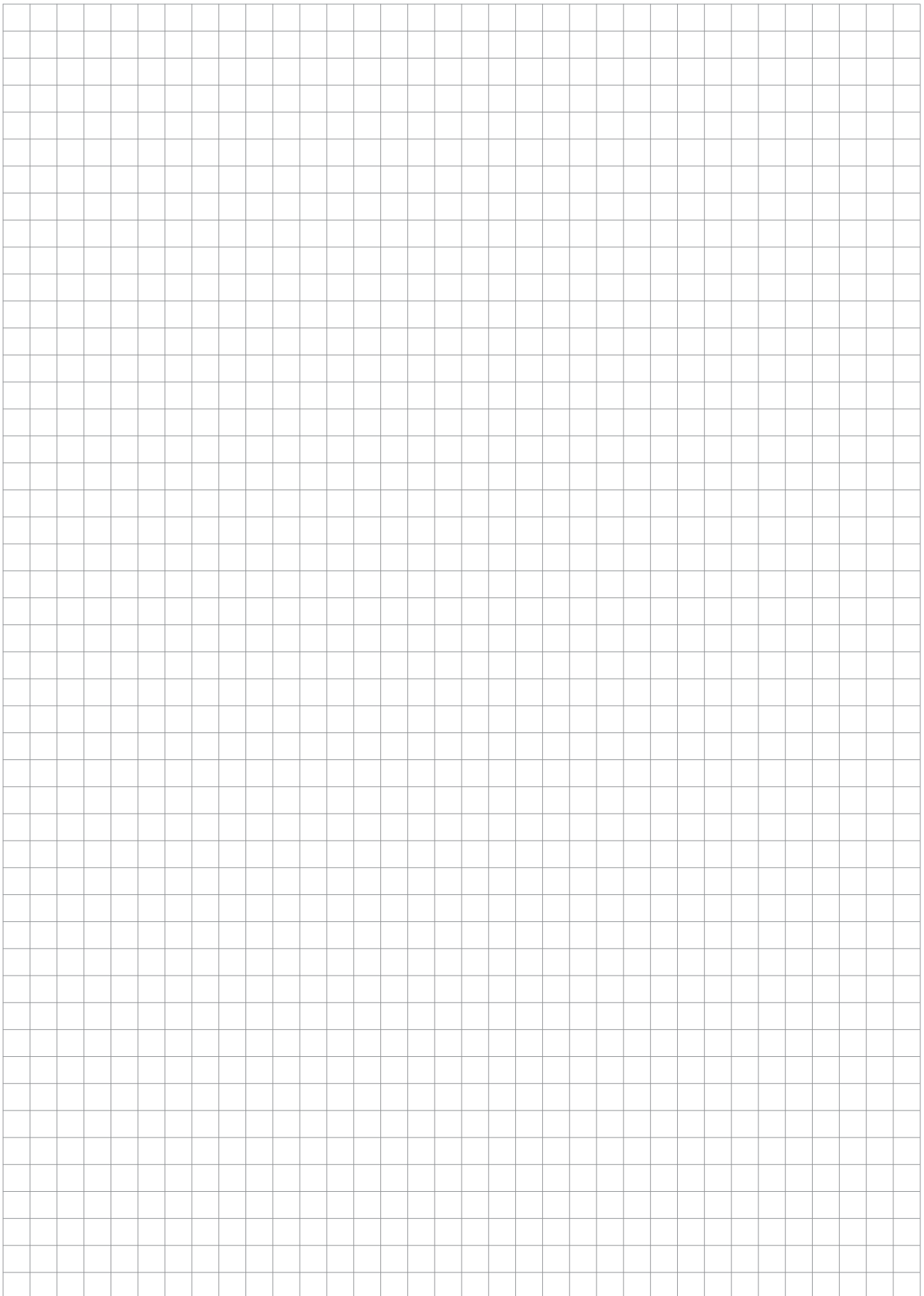

Y



Y



**FIND YOUR RIGHT
TOOLING SOLUTION NOW.**

www.hornusa.com

NORTH AMERICAN HEADQUARTERS

Horn USA, Inc.

1870 General George Patton Dr.
Franklin, TN 37067-2786
United States of America

Tel: +1 (888) 818-HORN

Fax: +1 (615) 771-4101

sales@hornusa.com

www.hornusa.com

Find your country:

www.phorn.com/countries