



NEW

MODULARES STECHSYSTEM 220

Grundhalter und Kassetten mit innerer Kühlmittelzufuhr

MODULAR GROOVING SYSTEM 220

Basic toolholder and cassettes with internal coolant supply

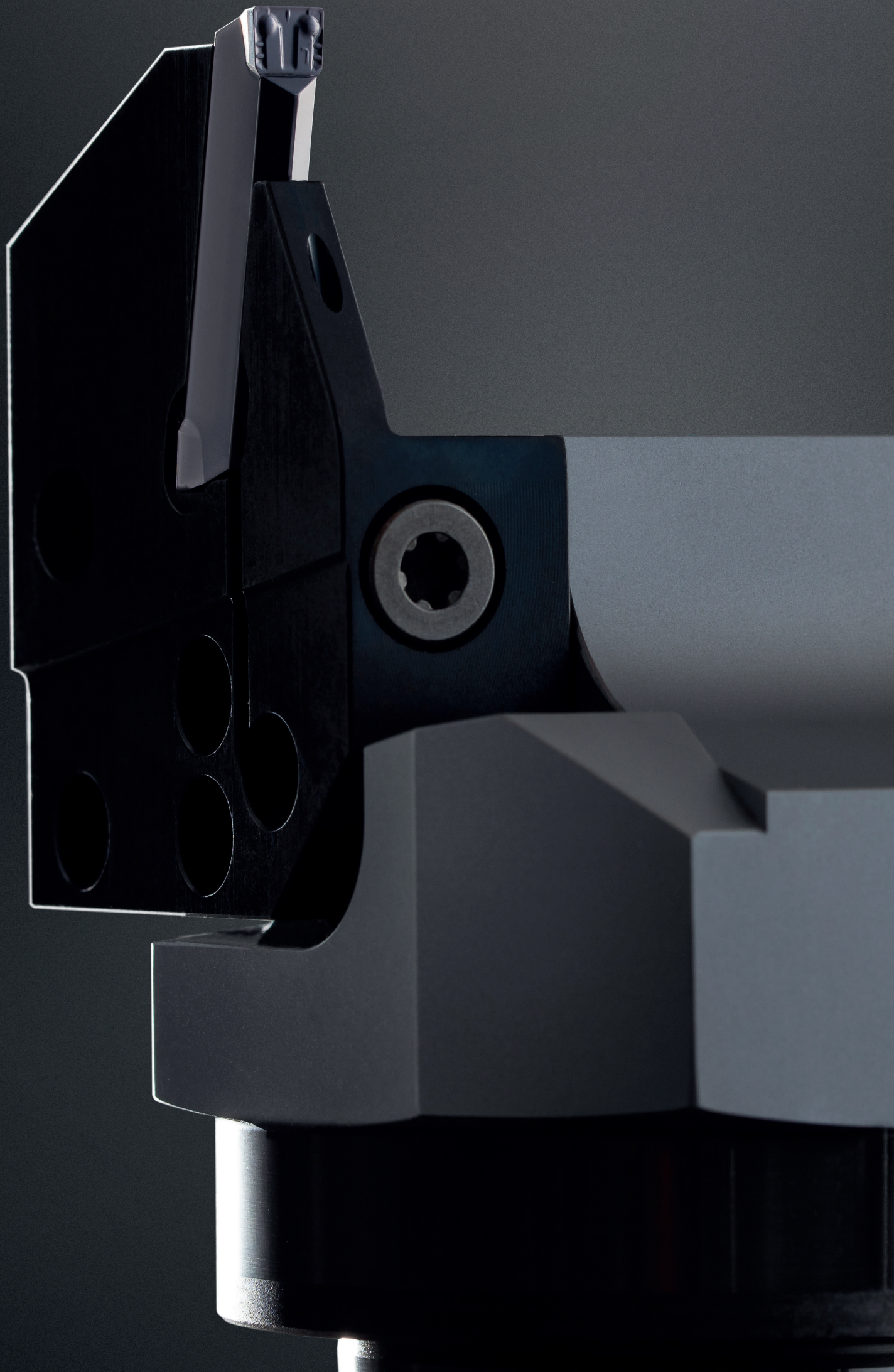

DER UNTERSCHIED: MEHR MÖGLICHKEITEN

THE DIFFERENCE:
MORE POSSIBILITIES

- **Universelle Grundhalter mit T-Schnittstelle für unterschiedliche Einstech-Kassetten**

Universal basic holder with interface „T“ for different grooving cassettes

- **Sehr stabile und wiederholgenaue Schnittstelle**

Very stable and repeatable interface

- **Höchste Performance durch zielgerichtet Kühlmittelzufuhr an die Schneide**

Highest performance through targeted coolant supply to the cutting edge

Grundhalter für die modularen Systeme HORN-Polygonschaft nach ISO 26623, HORN-Klemmhalter TS nach ISO 26622 und HSK sind durch unterschiedliche Kassetten zum Einstechen, Abstechen und Axialstechen verwendbar.

Die T-Schnittstelle mit "Nut und Feder" gewährleistet eine stabile und sichere Verbindung zwischen Kassette und Grundhalter. Diese Kassetten sind zudem für alle gängigen Schneidplattensysteme erhältlich.

Basic toolholder for the modular systems HORN Polygon shank according to ISO 26623, HORN Toolholder TS according to ISO 26622 and HSK with different cassettes are suitable for grooving, parting off and face grooving.

Excellent stability is guaranteed through the HORN designed interface „T“ between the cassette and the basic toolholder. The cassettes are available for all standard insert systems.

Modulares Werkzeugsystem Modular Tooling System

Außenbearbeitung External machining

Anbindung Coupling system	HORN-Polygon HORN Polygon ISO 26623	HORN TS ISO 26623	HSK DIN 69893	Vierkantschaft Square shank
0° gerade straight				
90° gekröpft cranked				
Ausführung rechts und links / Version right and left hand				

Kassetten-Programm Cassette programme

Typ Type	Schneidplatte Insert	R/LNK	R/LIK	R/LAK	Werkzeuglänge Tool length
360	312	•	-	-	$l = l_1 + l_K \text{ (Kassette)}$ (Cassette)
224	S224	•	•	•	
220	S229	•	•	•	
220	S100	•	-	-	
356	315/S315	•	-	-	
316	S316	•	-	-	
34T	S34T	•	-	-	
64T	S64T	•	-	-	
274	S274	•	-	-	

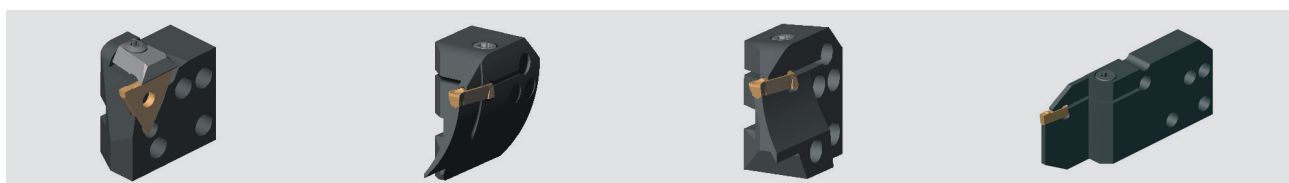

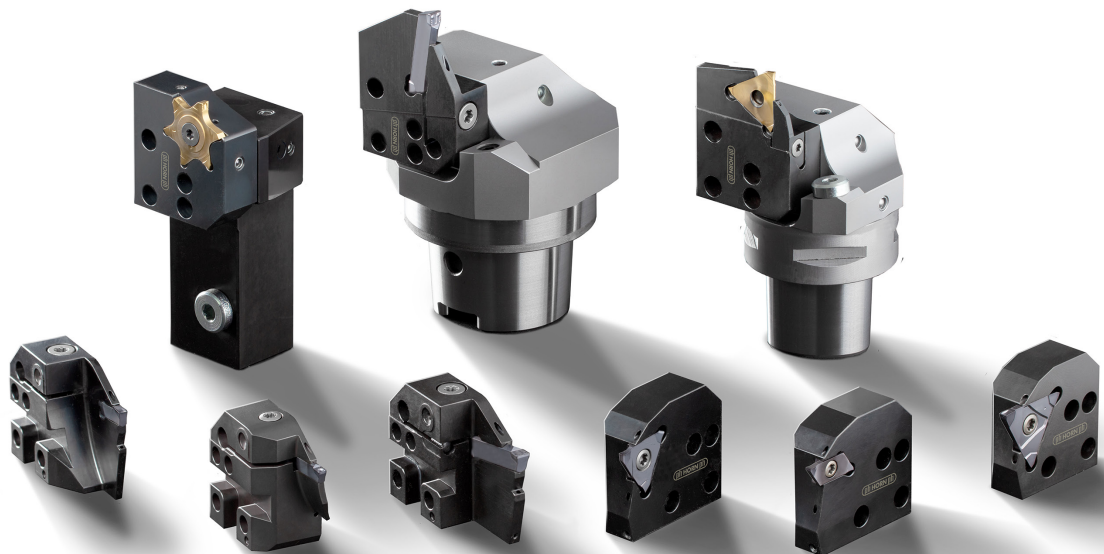

System/System	Seite/Page
Grundhalter	6
Basic Toolholder	
Radialbearbeitung	24
Radial Machining	
Axialbearbeitung	36
Axial Machining	

Grundhalter
Basic toolholder
220/B224/220C/
C5/220TS/HSK220/
HSKT63

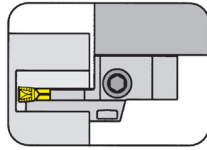

Seite/Page
10-11

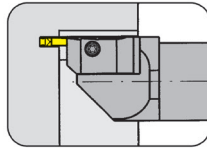

Seite/Page
12

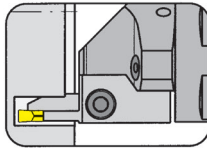

Seite/Page
13-21

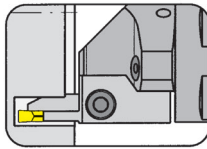

Seite/Page
22-23

Technische Hinweise
Technical Information

Seite/Page
63-65



Grundhalter für Kassetten

zur Radial- und Axialbearbeitung

**Basic toolholder for
cassettes**

for radial and axial machining

Grundhalter mit T-Schnittstelle

Basic holder with interface „T“

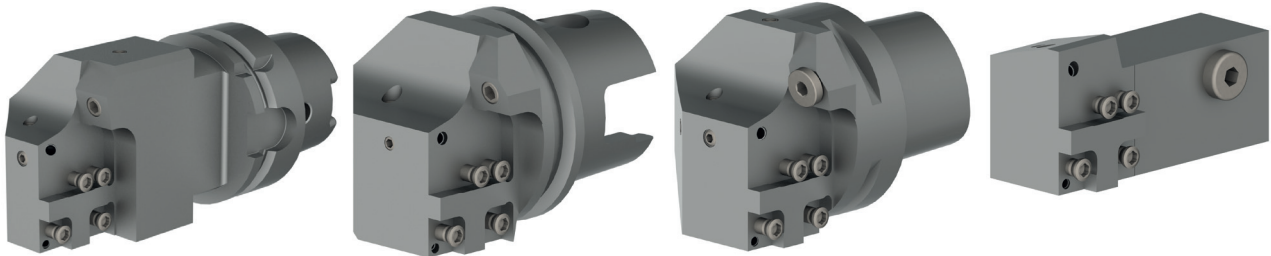

HSKT

Polygon

TS

Klemmhalter
Toolholder

Kassetten mit T-Schnittstelle

Cassettes with interface „T“

Einstecken radial
Grooving radial

Schneidplatte
Insert

Einstecken axial
Grooving axial

Schneidplatte
Insert

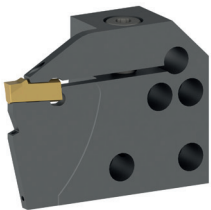

S100



S15A
S25A



S224
S229

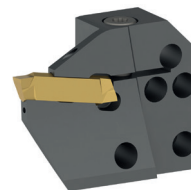

S224
S229

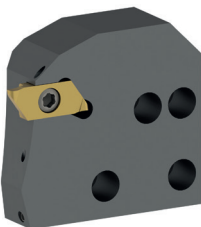

S274

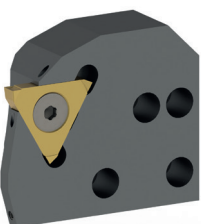

S34T

Grundhalter mit T-Schnittstelle

Basic holder with interface „T“

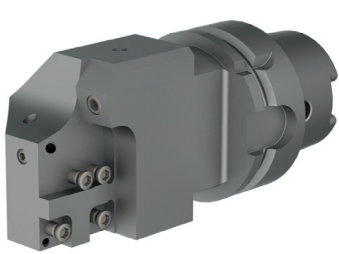

HSKT

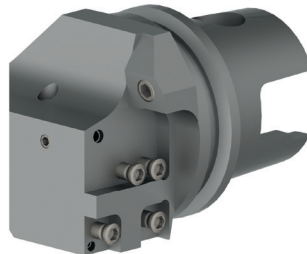

Polygon

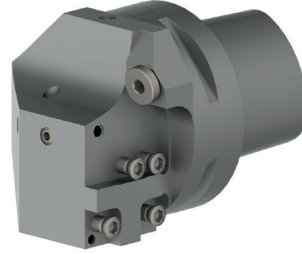

TS

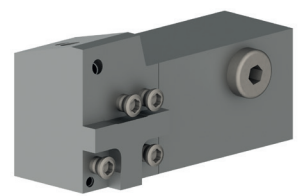

Klemmhalter
Toolholder

Kassetten mit T-Schnittstelle

Cassettes with interface „T“

Einstecken radial
Grooving radial

Schneidplatte
Insert

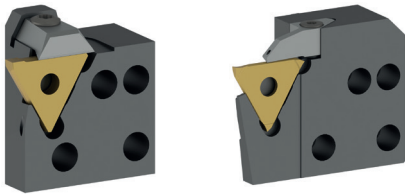

312

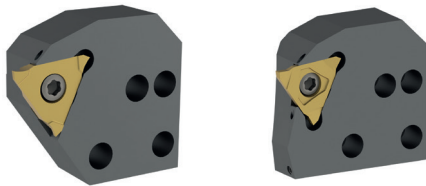

315
S315



64T

Axialeinstechen

Face Grooving



Grundhalter

Basic toolholder

220

ohne Kasette
without cassette

passend für HORN VDI-Aufnahmen mit integrierter Innenkühlung
passend für HORN VDI-Aufnahmen mit integrierter Innenkühlung

Schaft parallel zur Drehachse
Shank parallel to the axis of workpiece

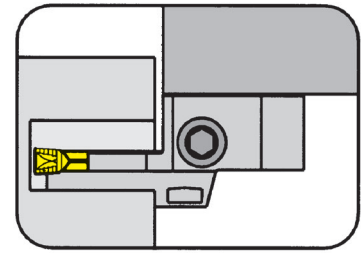

für Kassetten mit T-Schnittstelle
for Cassettes with interface „T“

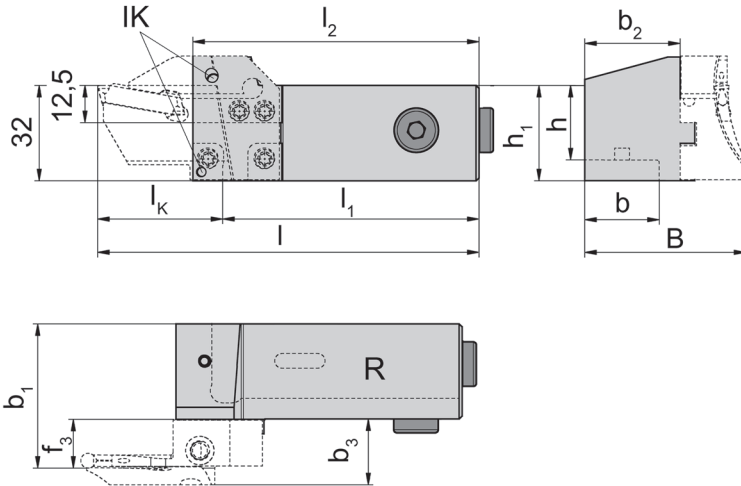

R = rechts wie gezeichnet
R = right hand version shown

L = Linksausführung
L = left hand version

mit integrierter innerer
Kühlmittelzufuhr
with integrated through
coolant supply

Bestellnummer Part number	h	h ₁	l ₁	b	b ₁	b ₂	l ₂	l	B
R/L220.2020.2.K1.IK	20	32	l ₂ -10	20	b ₂ +f ₃	27	84	l ₁ +l _K	b ₂ +b ₃
R/L220.2525.2.K1.IK	25	32	l ₂ -10	25	b ₂ +f ₃	32	96	l ₁ +l _K	b ₂ +b ₃

Ausführung R oder L angeben
State R or L version

l_K, b₃ und f₃ siehe Kassetten
l_K, b₃ and f₃ see cassettes

Abmessungen in mm
Dimensions in mm

Weitere Abmessungen auf Anfrage
Further sizes upon request

Rechte Grundhalter für rechte Kassetten und linke Grundhalter für linke Kassetten verwenden.
Use right hand basic toolholder for right hand cassettes and left hand basic toolholder for left hand cassettes.

Ersatzteile

Spare Parts

Grundhalter Basic toolholder	Spannschraube Clamping Screw	Dichtstopfen Sealing plug	Gewindestift Threaded Pin	O-Ring O-ring	TORX PLUS®-Schlüssel TORX PLUS® Wrench
R/L220...	5.12T20P	004.00.26	030.0508.0866	12.37.2.62.3601	T20PQ

Axialeinstechen

Face Grooving



Grundhalter

Basic toolholder

220

ohne Kasette
without cassette

passend für HORN VDI-Aufnahmen mit integrierter Innenkühlung
passend für HORN VDI-Aufnahmen mit integrierter Innenkühlung

Schaft 90° zur Drehachse
Shank 90° to the axis of workpiece

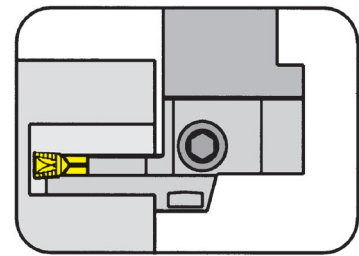

für Kassetten mit T-Schnittstelle
for Cassettes with interface „T“

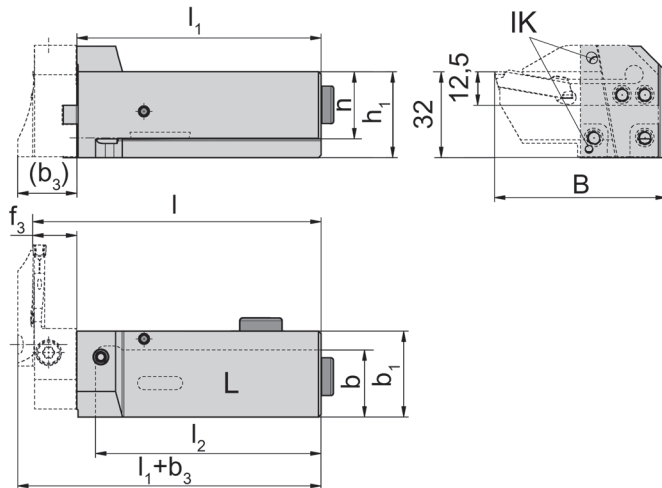

L = links wie gezeichnet
L = left hand version shown

R = Rechtsausführung
R = right hand version

mit integrierter innerer
Kühlmittelzufuhr
with integrated through
coolant supply

Bestellnummer Part number	h	h ₁	b	l ₂	l	B	b ₁	l ₁
R/L220.2020.2.K2.IK	20	32	20	69	l ₁ +f ₃	l _k +19	29	79
R/L220.2525.2.K2.IK	25	32	25	84	l ₁ +f ₃	l _k +19	32	91

Ausführung R oder L angeben
State R or L version

l_k, b₃ und f₃ siehe Kassetten
l_k, b₃ and f₃ see cassettes

Abmessungen in mm
Dimensions in mm

Weitere Abmessungen auf Anfrage
Further sizes upon request

Rechte Grundhalter für linke Kassetten und linke Grundhalter für rechte Kassetten verwenden.
Use right hand basic toolholder for left hand cassettes and left hand basic toolholder for right hand cassettes.

Ersatzteile

Spare Parts

Grundhalter Basic toolholder	Spannschraube Clamping Screw	Dichtstopfen Sealing plug	Gewindestift Threaded Pin	O-Ring O-ring	TORX PLUS®-Schlüssel TORX PLUS® Wrench
R/L220...	5.12T20P	004.00.26	030.0508.0866	12.37.2.62.3601	T20PQ

Axialeinstechen

Face Grooving



Grundhalter

Basic toolholder

B224

ohne Kasette
without cassette

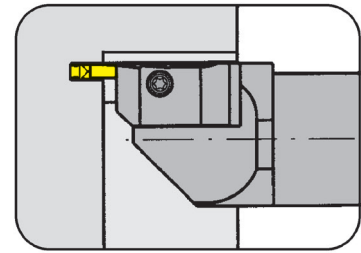

Grundhalter für Kassetten Typ RIK/LIK224
Grundhalter für Kassetten Typ RIK/LIK224

mit innerer Kühlmittelzufuhr
with through coolant supply

für Kassetten mit T-Schnittstelle
for Cassettes with interface „T“

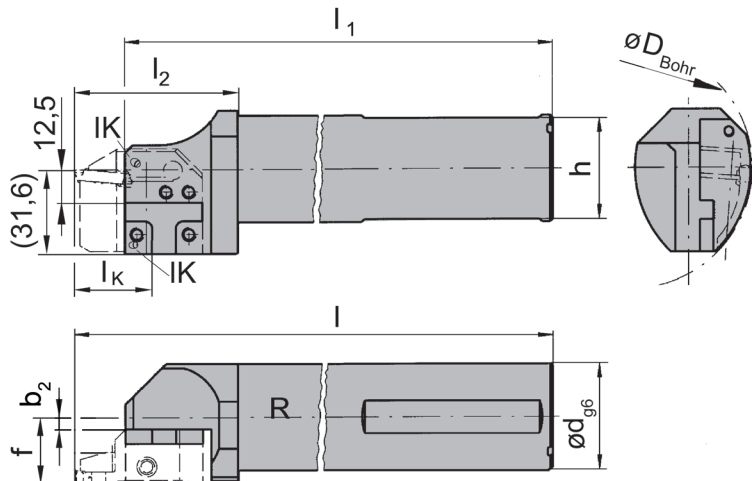

R = rechts wie gezeichnet
R = right hand version shown

L = Linksausführung
L = left hand version

Bestellnummer Part number	f	d	l ₁	h	l ₂	b ₂	l	D _{Bohr}
R/LB224.0032.K1.IK	b ₂ +f ₃	32	181	30	59	0,41	200	90
R/LB224.0040.K1.IK	b ₂ +f ₃	40	231	38	59	4,41	250	90

Ausführung R oder L angeben
State R or L version

D_{a min} / f₃ / l_K siehe Kassetten
D_{a min} / f₃ / l_K see cassettes

Abmessungen in mm
Dimensions in mm

Weitere Abmessungen auf Anfrage
Further sizes upon request

Ersatzteile

Spare Parts

Grundhalter Basic toolholder	Spannschraube Clamping Screw	TORX PLUS®-Schlüssel TORX PLUS® Wrench	Gewindestift Threaded Pin	Inbus-Schlüssel Allen Wrench
R/LB224...	5.12T20P	T20PQ	030.0508.0866	SW2,0 DIN911
RB224.0032.K1.IK	5.12T20P	T20PQ	030.0508.0866	SW2,5 DIN911

Ein-/Abstechen, Axialeinstechen

Grooving, Parting off and Face Grooving



Grundhalter

Basic toolholder

220C

ohne Kasette
without cassette

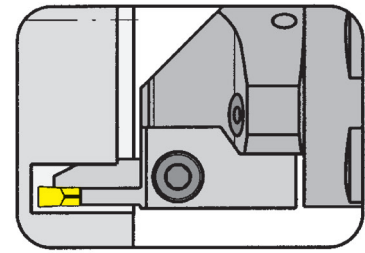

Grundhalter für Kassetten mit T-Schnittstelle
Basic toolholder for cassettes with interface „T“

mit innerer Kühlmittelzufuhr
with through coolant supply

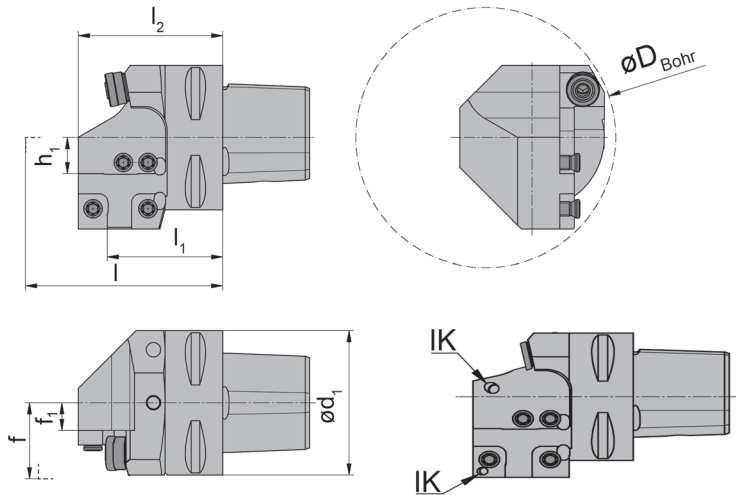

R = rechts wie gezeichnet
R = right hand version shown

L = Linksausführung
L = left hand version

Bestellnummer Part number	l_1	l	l_2	d_1	h_1	f_1	f
R/L220.00C3.K1.IK	36	$l_1 + l_K$	46	32	12,5	4,6	$f_1 + f_3$
R/L220.00C4.K1.IK	40	$l_1 + l_K$	50	40	12,5	4,6	$f_1 + f_3$
R/L220.00C5.K1.IK	40	$l_1 + l_K$	50	50	12,5	9,6	$f_1 + f_3$
R/L220.00C6.K1.IK	42	$l_1 + l_K$	52	63	12,5	16,1	$f_1 + f_3$
R/L220.00C8.K1.IK	53	$l_1 + l_K$	63	80	12,5	24,6	$f_1 + f_3$

Ausführung R oder L angeben
State R or L version

Abmessungen für D_{Bohr} , f_3 und l_K siehe Kassetten
Dimensions for D_{Bohr} , f_3 and l_K see cassettes

Abmessungen in mm
Dimensions in mm

Weitere Abmessungen auf Anfrage
Further sizes upon request

Hinweis:

R/L220...IK Kugelspritzdüse optional

Note:

R/L220...IK Coolant spray nozzle optional

Ersatzteile

Spare Parts

Grundhalter Basic toolholder	Spannschraube Clamping Screw	Gewindestift Threaded Pin	Inbus-Schlüssel Allen Wrench	Schraube Screw	TORX PLUS®-Schlüssel TORX PLUS® Wrench
R/L220...	5.12T20P	030.0508.0866	SW2,5 DIN911	004.00.21	T20PQ

Ein-/Abstechen, Axialeinstechen

Grooving, Parting off and Face Grooving



Grundhalter

Basic toolholder

220C

ohne Kassette
without cassette

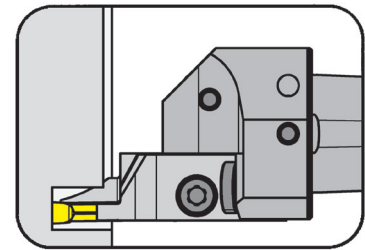

Grundhalter für Kassetten mit T-Schnittstelle
Basic toolholder for cassettes with interface „T“

mit innerer Kühlmittelzufuhr - ohne Greiferrille
with internal coolant supply - without tool changing groove

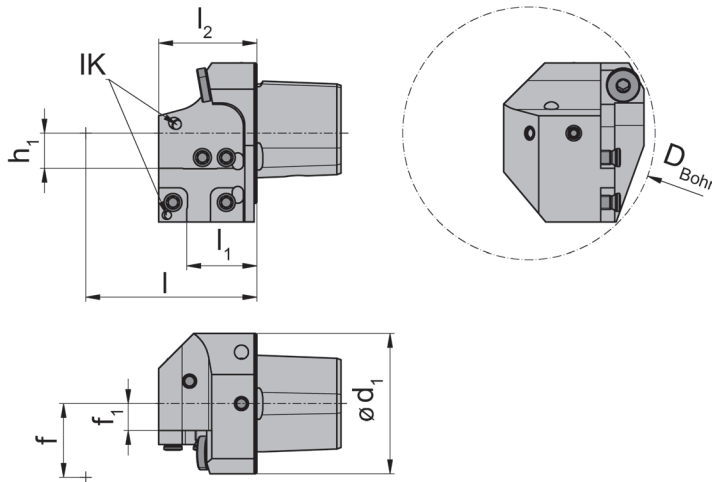

R = rechts wie gezeichnet
R = right hand version shown

L = Linksausführung
L = left hand version

Bestellnummer Part number	l_1	l	l_2	d_1	h_1	f_1	f
R/L220.00C4.K10.IK	25	$l_1 + l_k$	35	40	12,5	4,6	$f_1 + f_3$
R/L220.00C5.K10.IK	25	$l_1 + l_k$	35	50	12,5	9,6	$f_1 + f_3$

Ausführung R oder L angeben
State R or L version

Abmessungen für D_{Bohr} , f_3 und l_k siehe Kassetten
Dimensions for D_{Bohr} , f_3 and l_k see cassettes

Abmessungen in mm
Dimensions in mm

Weitere Abmessungen auf Anfrage

Further sizes upon request

R/L220...IK Kugelspritzdüse optional

R/L220...IK Coolant spray nozzle optional

Ersatzteile

Spare Parts

Grundhalter Basic toolholder	Spannschraube Clamping Screw	Gewindestift Threaded Pin	Inbus-Schlüssel Allen Wrench	Schraube Screw	TORX PLUS®-Schlüssel TORX PLUS® Wrench
R/L220...	5.12T20P	030.0508.0866	SW2,5 DIN911	004.00.21	T20PQ

Ein-/Abstechen, Axialeinstechen

Grooving, Parting off and Face Grooving



Grundhalter

Basic toolholder

220C

ohne Kassette
without cassette

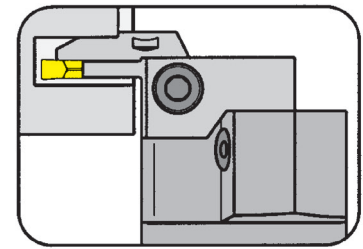

Grundhalter für Kassetten mit T-Schnittstelle
Basic toolholder for cassettes with interface „T“

mit innerer Kühlmittelzufuhr
with through coolant supply

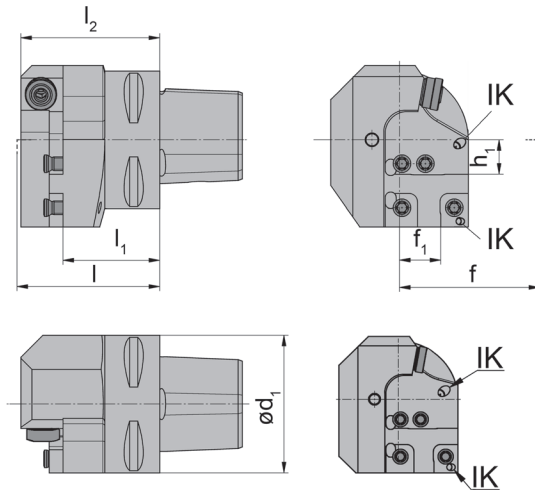

R = rechts wie gezeichnet
R = right hand version shown

L = Linksausführung
L = left hand version

Bestellnummer Part number	l_1	l	l_2	d_1	h_1	f_1	f
R/L220.00C3.K2.IK	31,2	l_1+f_3	46,5	32	12,5	10,0	f_1+l_K
R/L220.00C4.K2.IK	35,2	l_1+f_3	50,5	40	12,5	10,0	f_1+l_K
R/L220.00C5.K2.IK	35,2	l_1+f_3	50,5	50	12,5	15,0	f_1+l_K
R/L220.00C6.K2.IK	37,2	l_1+f_3	52,5	63	12,5	21,5	f_1+l_K
R/L220.00C8.K2.IK	48,2	l_1+f_3	63,5	80	12,5	30,0	f_1+l_K

Ausführung R oder L angeben
State R or L version

Abmessungen für D_{min} , f_3 und l_K siehe Kassetten
Dimensions for D_{min} , f_3 and l_K see cassettes

Abmessungen in mm
Dimensions in mm

Weitere Abmessungen auf Anfrage
Further sizes upon request

Hinweis:

R/L220...IK Kugelspritzdüse optional

Note:

R/L220...IK Coolant spray nozzle optional

Ersatzteile

Spare Parts

Grundhalter Basic toolholder	Spannschraube Clamping Screw	Gewindestift Threaded Pin	Inbus-Schlüssel Allen Wrench	Schraube Screw	TORX PLUS®-Schlüssel TORX PLUS® Wrench
R/L220...	5.12T20P	030.0508.0866	SW2,5 DIN911	004.00.21	T20PQ

Ein-/Abstechen, Axialeinstechen

Grooving, Parting off and Face Grooving



Grundhalter

Basic toolholder

220C

ohne Kassette
without cassette

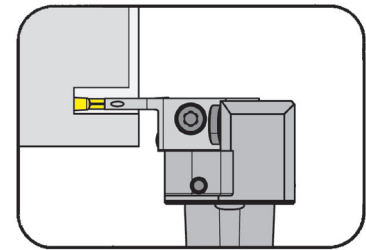

Grundhalter für Kassetten mit T-Schnittstelle
Basic toolholder for cassettes with interface „T“

mit innerer Kühlmittelzufuhr - ohne Greiferrille
with internal coolant supply - without tool changing groove

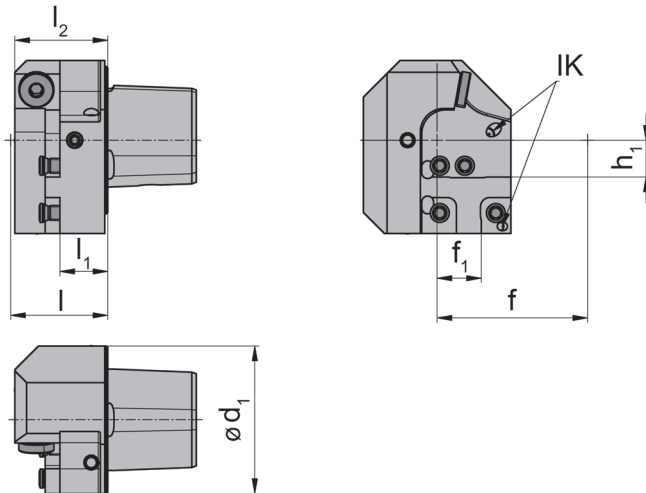

R = rechts wie gezeichnet
R = right hand version shown

L = Linksausführung
L = left hand version

Bestellnummer Part number	l_1	l	l_2	d_1	h_1	f_1	f
R/L220.00C4.K20.IK	16,2	l_1+f_3	31,5	40	12,5	10	f_1+l_k
R/L220.00C5.K20.IK	16,2	l_1+f_3	31,5	50	12,5	15	f_1+l_k

Ausführung R oder L angeben
State R or L version

Abmessungen für D_{min} , f_3 und l_k siehe Kassetten
Dimensions for D_{min} , f_3 and l_k see cassettes

Abmessungen in mm
Dimensions in mm

Weitere Abmessungen auf Anfrage

Further sizes upon request

R/L220...IK Kugelspritzdüse optional

R/L220...IK Coolant spray nozzle optional

Ersatzteile

Spare Parts

Grundhalter Basic toolholder	Spannschraube Clamping Screw	Gewindestift Threaded Pin	Inbus-Schlüssel Allen Wrench	Schraube Screw	TORX PLUS®-Schlüssel TORX PLUS® Wrench
R/L220...	5.12T20P	030.0508.0866	SW2,5 DIN911	004.00.21	T20PQ

Ein-/Abstechen, Axialeinstechen

Grooving, Parting off and Face Grooving



Grundhalter

Basic toolholder

C5/C6/C8

ohne Kasette
without cassette

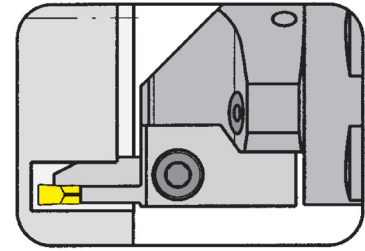

Grundhalter für Kassetten mit T-Schnittstelle
Basic toolholder for cassettes with interface „T“

mit innerer Kühlmittelzufuhr
with through coolant supply

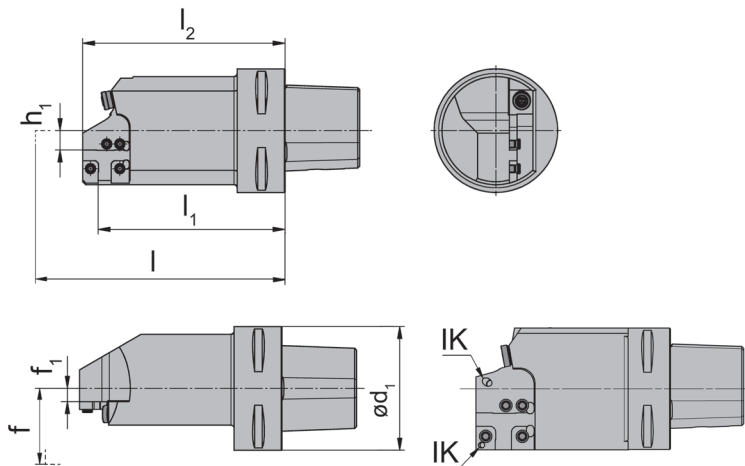

R = rechts wie gezeichnet
R = right hand version shown

L = Linksausführung
L = left hand version

Bestellnummer Part number	l_1	l	l_2	d_1	h_1	f_1	f
C6.L220.120.K1.IK	91	l_1+l_k	101	63	12,5	0,6	f_1+f_3
C6.R220.120.K1.IK	91	l_1+l_k	101	63	12,5	0,6	f_1+f_3
C6.L220.150.K1.IK	121	l_1+l_k	131	63	12,5	0,6	f_1+f_3
C6.R220.150.K1.IK	121	l_1+l_k	131	63	12,5	0,6	f_1+f_3

Ausführung R oder L angeben
State R or L version

Abmessungen für f_3 und l_k siehe Kassetten
Dimensions for f_3 and l_k see cassettes

Abmessungen in mm
Dimensions in mm

Weitere Abmessungen auf Anfrage
Further sizes upon request

Hinweis:

C6.R/L220...IK Kugelspritzdüse optional

Note:

C6.R/L220...IK Coolant spray nozzle optional

Ersatzteile

Spare Parts

Grundhalter Basic toolholder	Spannschraube Clamping Screw	Gewindestift Threaded Pin	Inbus-Schlüssel Allen Wrench	Schraube Screw	TORX PLUS®-Schlüssel TORX PLUS® Wrench
C6...	5.12T20P	030.0508.0866	SW2,5 DIN911	004.00.21	T20PQ

Ein-/Abstechen, Axialeinstechen

Grooving, Parting off and Face Grooving



Grundhalter

Basic toolholder

220TS

ohne Kasette
without cassette

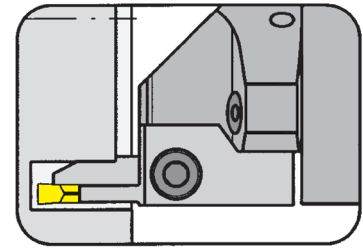

Grundhalter für Kassetten mit T-Schnittstelle
Basic toolholder for cassettes with interface „T“

mit innerer Kühlmittelzufuhr
with through coolant supply

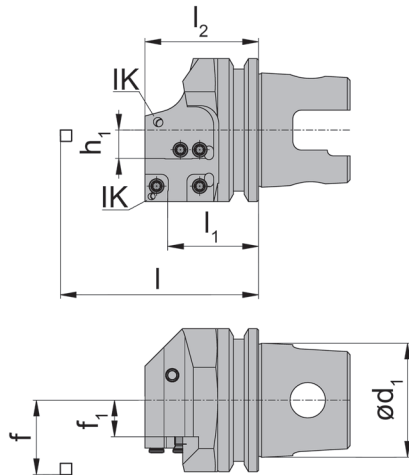

R = rechts wie gezeichnet
R = right hand version shown

L = Linksausführung
L = left hand version

Bestellnummer Part number	l_1	l	l_2	d_1	h_1	f_1	f
R/L220.TS40.K1.IK	40	$l_1 + l_K$	50	40	12,5	4,6	$f_1 + f_3$
R/L220.TS50.K1.IK	40	$l_1 + l_K$	50	50	12,5	9,6	$f_1 + f_3$
R/L220.TS63.K1.IK	40	$l_1 + l_K$	50	63	12,5	16,1	$f_1 + f_3$

Ausführung R oder L angeben
State R or L version

Abmessungen für D_{Bohr} , f_3 und l_K siehe Kassetten
Dimensions for D_{Bohr} , f_3 and l_K see cassettes

Abmessungen in mm
Dimensions in mm

Weitere Abmessungen auf Anfrage
Further sizes upon request

Ersatzteile

Spare Parts

Grundhalter Basic toolholder	Spannschraube Clamping Screw	Kugelspritzdüse Coolant spray nozzle	TORX PLUS®-Schlüssel TORX PLUS® Wrench	Gewindestift Threaded Pin	Inbus-Schlüssel Allen Wrench
R/L220.TS40.K1.IK	5.12T20P	020.1008.2977	T20PQ		
R/L220.TS50.K1.IK	5.12T20P	020.1008.2977	T20PQ	030.0508.0866	
R/L220.TS63.K1.IK	5.12T20P	020.1008.2977	T20PQ	030.0508.0866	SW2,5 DIN911

Ein-/Abstechen, Axialeinstechen

Grooving, Parting off and Face Grooving



Grundhalter

Basic toolholder

220TS

ohne Kasette
without cassette

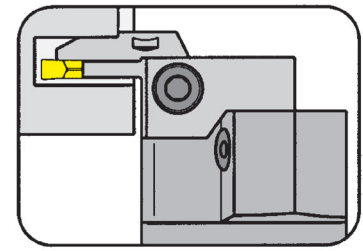

Grundhalter für Kassetten mit T-Schnittstelle
Basic toolholder for cassettes with interface „T“

mit innerer Kühlmittelzufuhr
with through coolant supply

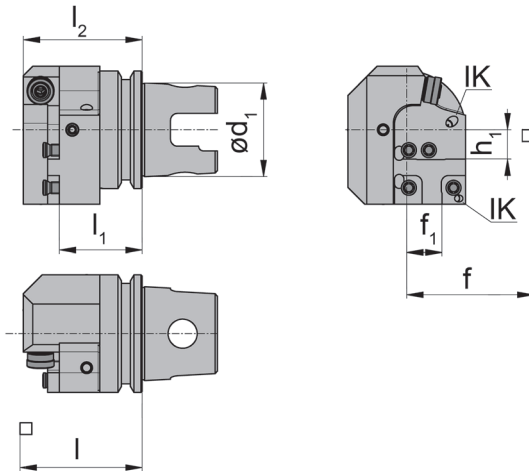

R = rechts wie gezeichnet
R = right hand version shown

L = Linksausführung
L = left hand version

Bestellnummer Part number	l_1	l	l_2	d_1	h_1	f_1	f
R/L220.TS40.K2.IK	35,2	l_1+f_3	50,5	40	12,5	10,0	f_1+l_k
R/L220.TS50.K2.IK	35,2	l_1+f_3	50,5	50	12,5	15,0	f_1+l_k
L220.TS63.K2.IK	35,2	l_1+f_3	50,5	63	12,5	21,5	f_1+l_k

Ausführung R oder L angeben
State R or L version

Abmessungen für D_{Bohr} , f_3 und l_k siehe Kassetten
Dimensions for D_{Bohr} , f_3 and l_k see cassettes

Abmessungen in mm
Dimensions in mm

Weitere Abmessungen auf Anfrage
Further sizes upon request

Ersatzteile

Spare Parts

Grundhalter Basic toolholder	Spannschraube Clamping Screw	Gewindestift Threaded Pin	Kugelspritzdüse Coolant spray nozzle	TORX PLUS®-Schlüssel TORX PLUS® Wrench	Inbus-Schlüssel Allen Wrench
R/L220.T...	5.12T20P	030.0508.0866	020.1008.2977	T20PQ	
L220.TS63.K2.IK	5.12T20P	030.0508.0866	020.1008.2977	T20PQ	SW2,5 DIN911

Ein-/Abstechen, Axialeinstechen

Grooving, Parting off and Face Grooving



Grundhalter

Basic toolholder

HSK220

ohne Kasette
without cassette

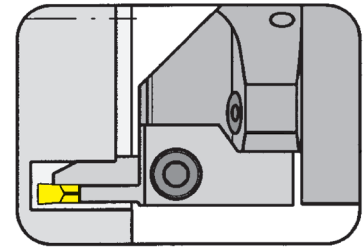

Grundhalter für Kassetten mit T-Schnittstelle
Basic toolholder for cassettes with interface „T“

für manuellen Werkzeugwechsel, mit innerer Kühlmittelzufuhr
for manual tool change, with through coolant supply

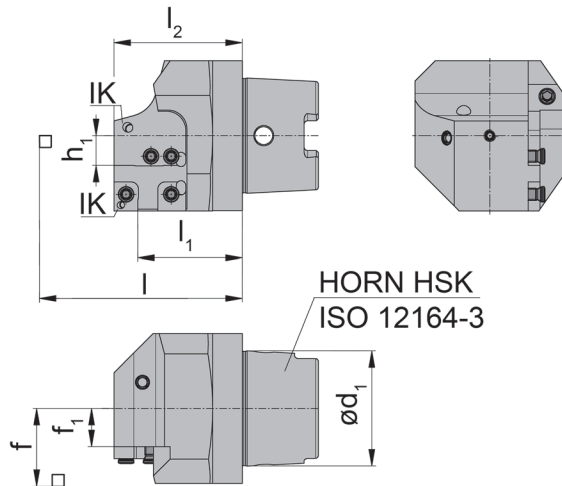

HORN HSK
ISO 12164-3

R = rechts wie gezeichnet
R = right hand version shown

L = Linksausführung
L = left hand version

Bestellnummer Part number	l_1	d_1	f_1	l	l_2	f	h_1
HSK-L220.0063.K1.IK	44	63	16,1	$l_1 + l_K$	54	$f_1 + f_3$	12,5
HSK-R220.0063.K1.IK	44	63	16,1	$l_1 + l_K$	54	$f_1 + f_3$	12,5

Ausführung R oder L angeben
State R or L version

Abmessungen für D_{min} , f_3 und l_K siehe Kassetten
Dimensions for D_{min} , f_3 and l_K see cassettes

Abmessungen in mm
Dimensions in mm

Weitere Größen und Ausführungen (z.B. HSK-B50 usw.) auf Anfrage
Further sizes and versions (e.g. HSK-B50 etc.) upon request

Ersatzteile

Spare Parts

Grundhalter Basic toolholder	Spannschraube Clamping Screw	Gewindestift Threaded Pin	Inbus-Schlüssel Allen Wrench	Kugelspritzdüse Coolant spray nozzle	TORX PLUS®-Schlüssel TORX PLUS® Wrench
HSK-L220...	5.12T20P	030.0508.0866	SW2,5 DIN911	020.1008.2977	T20PQ

Ein-/Abstechen, Axialeinstechen

Grooving, Parting off and Face Grooving



Grundhalter

Basic toolholder

HSK220

ohne Kasette
without cassette

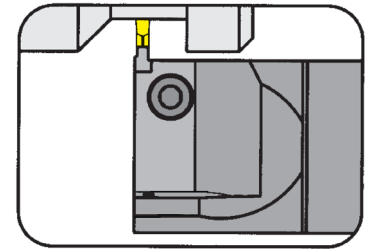

Grundhalter für Kassetten mit T-Schnittstelle
Basic toolholder for cassettes with interface „T“

für manuellen Werkzeugwechsel, mit innerer Kühlmittelzufuhr
for manual tool change, with through coolant supply

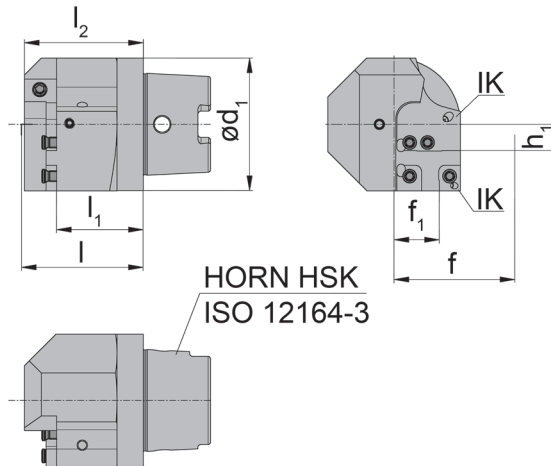

R = rechts wie gezeichnet
R = right hand version shown

L = Linksausführung
L = left hand version

Bestellnummer Part number	l_1	d_1	f_1	l	l_2	f	h_1
HSK-L220.0063.K2.IK	41,2	63	21,5	l_1+f_3	56,5	f_1+l_k	12,5
HSK-R220.0063.K2.IK	41,2	63	21,5	l_1+f_3	56,5	f_1+l_k	12,5

Ausführung R oder L angeben
State R or L version

Abmessungen für D_{min} , f_3 und l_k siehe Kassetten
Dimensions for D_{min} , f_3 and l_k see cassettes

Abmessungen in mm
Dimensions in mm

Weitere Größen und Ausführungen (z.B. HSK-B50 usw.) auf Anfrage
Further sizes and versions (e.g. HSK-B50 etc.) upon request

Ersatzteile

Spare Parts

Grundhalter Basic toolholder	Spannschraube Clamping Screw	Gewindestift Threaded Pin	Inbus-Schlüssel Allen Wrench	Kugelspritzdüse Coolant spray nozzle	TORX PLUS®-Schlüssel TORX PLUS® Wrench
HSK-L220...	5.12T20P	030.0508.0866	SW2,5 DIN911	020.1008.2977	T20PQ

Ein-/Abstechen, Axialeinstechen

Grooving, Parting off and Face Grooving



Grundhalter

Basic toolholder

HSKT63

ohne Kasette
without cassette

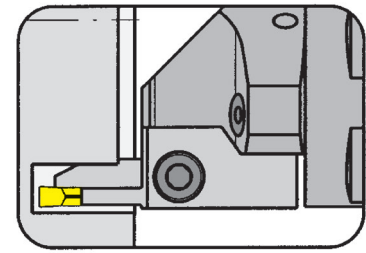

Grundhalter für Kassetten mit T-Schnittstelle
Basic toolholder for cassettes with interface „T“

mit innerer Kühlmittelzufuhr
with through coolant supply

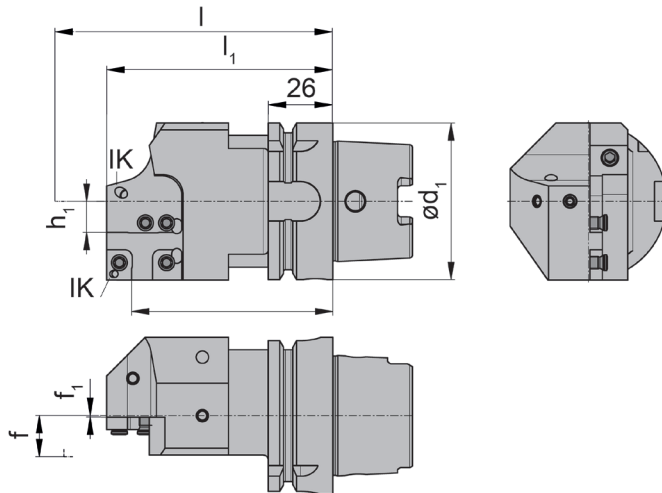

R = rechts wie gezeichnet
R = right hand version shown

L = Linksausführung
L = left hand version

Kassetzensitz System 220
Pocket seat system 220

Bestellnummer Part number	Kassette Cassette	l_1	d	f_1	l	l_2	f	h_1
HSKT63.L220.110.K1.IK	L	81	63	0,6	l_1+l_k	91	f_1+f_3	12,5
HSKT63.L220.120.K1.IK	L	91	63	0,6	l_1+l_k	101	f_1+f_3	12,5
HSKT63.L220.130.K1.IK	L	101	63	0,6	l_1+l_k	111	f_1+f_3	12,5
HSKT63.L220.150.K1.IK	L	121	63	0,6	l_1+l_k	131	f_1+f_3	12,5
HSKT63.L220.175.K1.IK	L	146	63	0,6	l_1+l_k	156	f_1+f_3	12,5
HSKT63.R220.110.K1.IK	R	81	63	0,6	l_1+l_k	91	f_1+f_3	12,5
HSKT63.R220.120.K1.IK	R	91	63	0,6	l_1+l_k	101	f_1+f_3	12,5
HSKT63.R220.130.K1.IK	R	101	63	0,6	l_1+l_k	111	f_1+f_3	12,5
HSKT63.R220.150.K1.IK	R	121	63	0,6	l_1+l_k	131	f_1+f_3	12,5
HSKT63.R220.175.K1.IK	R	146	63	0,6	l_1+l_k	156	f_1+f_3	12,5

Weitere Abmessungen auf Anfrage
Further sizes upon request

l_k und f_3 siehe Kassetten
 l_k and f_3 see cassettes

Abmessungen in mm
Dimensions in mm

Ersatzteile

Spare Parts

Grundhalter Basic toolholder	Spannschraube Clamping Screw	Gewindestift Threaded Pin	Inbus-Schlüssel Allen Wrench	Kugelspritzdüse Coolant spray nozzle	TORX PLUS®-Schlüssel TORX PLUS® Wrench
HSKT63...	5.12T20P	030.0508.0866	SW2,5 DIN911	020.1008.2977	T20PQ

Ein-/Abstechen, Axialeinstechen

Grooving, Parting off and Face Grooving



Grundhalter

Basic toolholder

HSKT63

ohne Kassette
without cassette

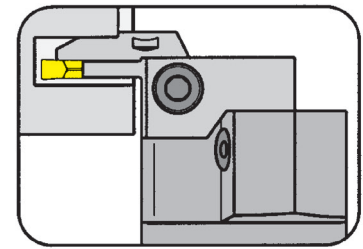

Grundhalter für Kassetten mit T-Schnittstelle
Basic toolholder for cassettes with interface „T“

mit innerer Kühlmittelzufuhr
with through coolant supply

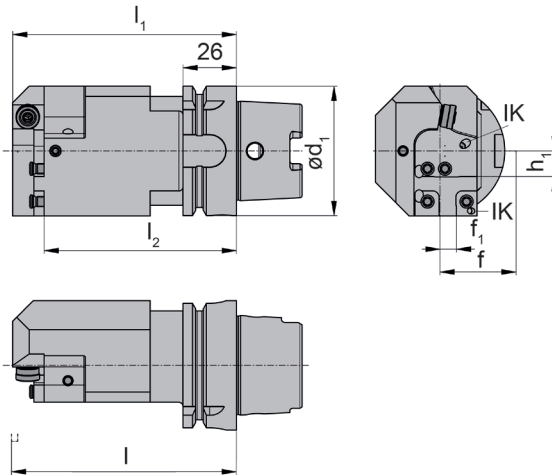

R = rechts wie gezeichnet
R = right hand version shown

L = Linksausführung
L = left hand version

Kassetzensitz System 220
Pocket seat system 220

Bestellnummer Part number	Kassette Cassette	l_1	d	f_1	l	l_2	f	h_1
HSKT63.L220.110.K2.IK	R	93,6	63	8,0	l_1+l_k	108,8	f_1+l_k	12,5
HSKT63.L220.130.K2.IK	R	101,0	63	0,6	l_1+l_k	111,0	f_1+f_3	12,5
HSKT63.L220.150.K2.IK	R	133,6	63	8,0	l_1+l_k	148,8	f_1+l_k	12,5
HSKT63.L220.175.K2.IK	R	158,6	63	8,0	l_1+l_k	173,8	f_1+l_k	12,5
HSKT63.R220.110.K2.IK	L	93,6	63	8,0	l_1+l_k	108,8	f_1+l_k	12,5
HSKT63.R220.130.K2.IK	L	113,6	63	8,0	l_1+l_k	128,8	f_1+l_k	12,5
HSKT63.R220.150.K2.IK	L	133,6	63	8,0	l_1+l_k	148,8	f_1+l_k	12,5
HSKT63.R220.175.K2.IK	L	158,6	63	8,0	l_1+l_k	173,8	f_1+l_k	12,5

Weitere Abmessungen auf Anfrage
Further sizes upon request

l_k siehe Kassetten
 l_k see cassettes

Abmessungen in mm
Dimensions in mm

Ersatzteile

Spare Parts

Grundhalter Basic toolholder	Spannschraube Clamping Screw	Gewindestift Threaded Pin	Inbus-Schlüssel Allen Wrench	Kugelspritzdüse Coolant spray nozzle	TORX PLUS®-Schlüssel TORX PLUS® Wrench
HSKT63...	5.12T20P	030.0508.0866	SW2,5 DIN911	020.1008.2977	T20PQ

Einstecken (außen)

Grooving (external)



Kassette

Cassette

NK100/NK224/

NK220/NK274/

NK34T/NK360/

NK368/NK356/

NK316/NK64T

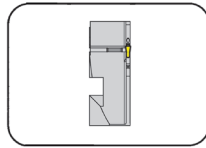

Seite/Page
26-35

Technische Hinweise
Technical Information

Seite/Page
63-65



**Kassetten zur
Radialbearbeitung**

mit innerer Kühlmittelzufuhr

**Cassettes for
radial machining**

with through coolant supply

Einstecken (außen)

Grooving (external)



Kassette

Cassette

NK100

mit innerer Kühlmittelzufuhr
with through coolant supply

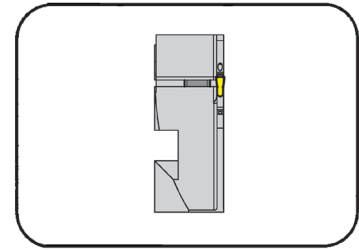

Stechtiefe bis Depth of groove up to 25 mm

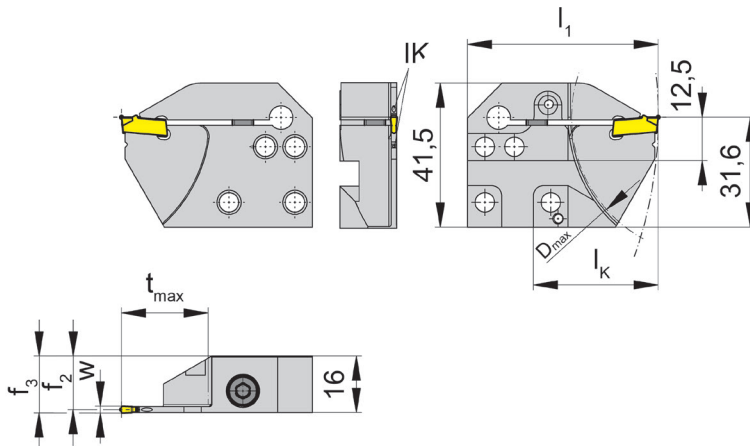

für Schneidplatte
for Insert

Typ S100
Type

R = rechts wie gezeichnet
R = right hand version shown

L = links spiegelbildlich
L = left hand version

Bestellnummer Part number	t _{max}	f ₂	f ₃	w	D _{max}	I ₁	I _k
R/LNK100.3215.4.21.IK	25	15,40	f ₂ +w/2	2,0	80	55	36
R/LNK100.3215.4.22.IK	25	15,15	f ₂ +w/2	2,5	80	55	36
R/LNK100.3215.4.23.IK	25	14,90	f ₂ +w/2	3,0	80	55	36
R/LNK100.3215.4.24.IK	25	14,40	f ₂ +w/2	4,0	80	55	36

Ausführung R oder L angeben
State R or L version

w siehe Schneidplatten
w see inserts

Abmessungen in mm
Dimensions in mm

Bestellhinweis:

Befestigungsschrauben der Kassetten gehören zum Lieferumfang des Grundhalters.

Ordering note:

The fastening screw is combined with the basic toolholder - no separate order required.

Das Anzugsdrehmoment der Schrauben finden Sie in den Technischen Hinweisen.

For torque specification of the screw, please see Technical Instructions.

Kühlmittelaustritt:

Durch Spannfinger und Unterstützung

Coolant outlet:

Through clamping finger and insert support

Ersatzteile

Spare Parts

Kassette Cassette	Spannschraube Clamping Screw	TORX PLUS®-Schlüssel TORX PLUS® Wrench
R/LNK100...	6.23T25P	T25PQ

Einstecken (außen)

Grooving (external)



Kassette

Cassette

NK224

mit innerer Kühlmittelzufuhr
with through coolant supply

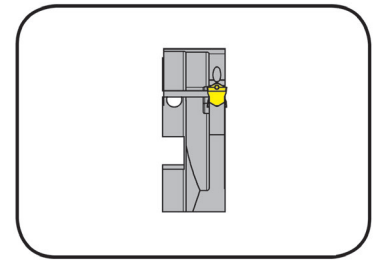

Stechtiefe bis
Spannbereich

Depth of groove up to
Clamping range

18 mm
2,8-6 mm

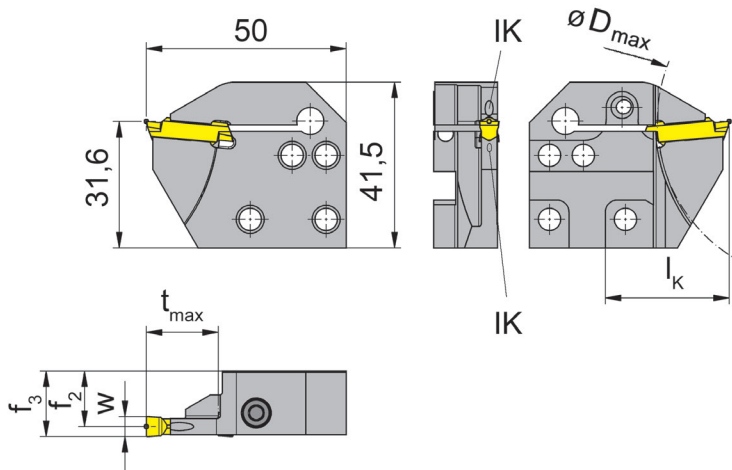

für Wendeschneidplatte
for Indexable insert

Typ S224
Type

R = rechts wie gezeichnet
R = right hand version shown

L = links spiegelbildlich
L = left hand version

Bestellnummer Part number	t_{max}	f_2	f_3	D_{max}	l_K	Spannbereich Clamping range
R/LNK224.3215.2.01.IK	18	15,40	$f_2+w/2$	80	31	2,0-2,4
R/LNK224.3215.2.02.IK	18	15,15	$f_2+w/2$	80	31	2,4-2,8
R/LNK224.3215.4.03.IK	18	14,90	$f_2+w/2$	80	31	2,8-3,7
R/LNK224.3215.4.04.IK	18	14,40	$f_2+w/2$	80	31	3,7-4,4
R/LNK224.3215.4.05.IK	18	13,90	$f_2+w/2$	80	31	4,4-5,1
R/LNK224.3215.4.06.IK	18	13,40	$f_2+w/2$	80	31	5,1-6,0

Ausführung R oder L angeben
State R or L version

w siehe Schneidplatten
w see inserts

Abmessungen in mm
Dimensions in mm

Bestellhinweis:

Befestigungsschrauben der Kassetten gehören zum Lieferumfang des Grundhalters.

Ordering note:

The fastening screw is combined with the basic toolholder - no separate order required.

Das Anzugsdrehmoment der Schrauben finden Sie in den Technischen Hinweisen.

For torque specification of the screw, please see Technical Instructions.

Kühlmittelaustritt:

.2. = Durch Unterstützung

.4. = Durch Spannfinger und Unterstützung

Coolant outlet:

.2. = Through insert support

.4. = Through clamping finger and insert support

Ersatzteile

Spare Parts

Kassette Cassette	Spannschraube Clamping Screw	TORX PLUS®-Schlüssel TORX PLUS® Wrench
R/LNK224...	5.13 T20P	T20PQ

Einstecken (außen)

Grooving (external)



Kassette

Cassette

NK220

mit innerer Kühlmittelzufuhr
with through coolant supply

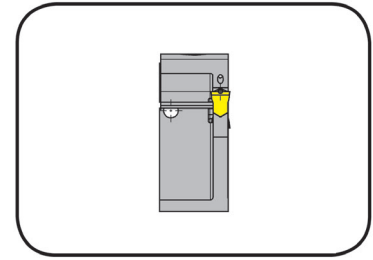

Stechtiefe bis
Spannbereich

Depth of groove up to
Clamping range

25 mm
3-6,09 mm

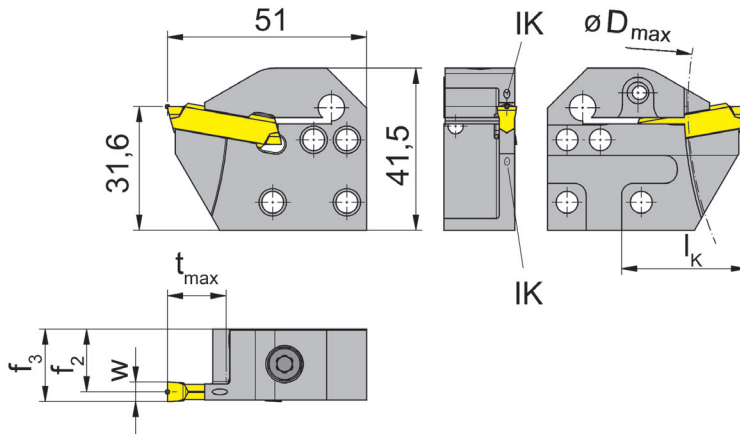

für Wendeschneidplatte
for Indexable insert

Typ S229
Type

R = rechts wie gezeichnet
R = right hand version shown

L = links spiegelbildlich
L = left hand version

Bestellnummer Part number	t _{max}	f ₂	f ₃	D _{max}	l _k	Spannbereich Clamping range
R/LNK220.3218.4.13.IK	15	17,1	f ₂ +w/2	180	32	3,00-3,80
R/LNK220.3218.4.14.IK	15	16,6	f ₂ +w/2	180	32	3,80-4,40
R/LNK220.3218.4.15.IK	15	16,1	f ₂ +w/2	180	32	4,40-5,09
R/LNK220.3218.4.16.IK	15	15,6	f ₂ +w/2	180	32	5,10-6,09
R/LNK220.3215.4.03.IK	25	14,9	f ₂ +w/2	-	38	3,00-3,80
R/LNK220.3215.4.04.IK	25	14,4	f ₂ +w/2	-	38	3,80-4,40
R/LNK220.3215.4.05.IK	25	13,9	f ₂ +w/2	-	38	4,40-5,09
R/LNK220.3215.4.06.IK	25	13,4	f ₂ +w/2	-	38	5,10-6,09

Ausführung R oder L angeben
State R or L version

w siehe Schneidplatten
w see inserts

Abmessungen in mm
Dimensions in mm

Bestellhinweis:

Befestigungsschrauben der Kassetten gehören zum Lieferumfang des Grundhalters.

Ordering note:

The fastening screw is combined with the basic toolholder - no separate order required.

Das Anzugsdrehmoment der Schrauben finden Sie in den Technischen Hinweisen.

For torque specification of the screw, please see Technical Instructions.

Kühlmittelaustritt:

Durch Spannfinger und Unterstüzung

Coolant outlet:

Through clamping finger and insert support

Ersatzteile

Spare Parts

Kassette Cassette	Spannschraube Clamping Screw	TORX PLUS®-Schlüssel TORX PLUS® Wrench
R/LNK220...	6.23T25P	T25PQ

Einstecken (außen)

Grooving (external)



Kassette

Cassette

NK274

mit innerer Kühlmittelzufuhr
with through coolant supply

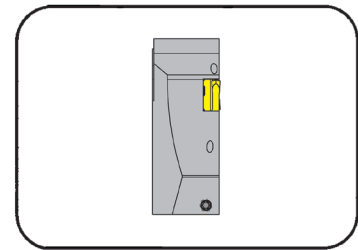

Stechtiefe bis
Spannbereich

Depth of groove up to
Clamping range

6 mm
4 mm

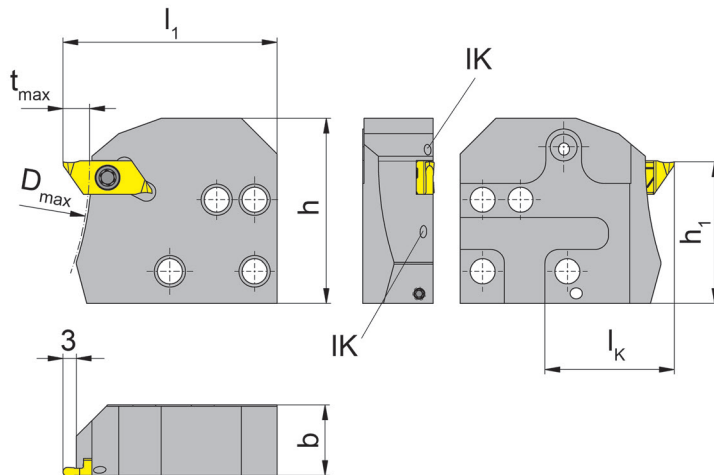

für Wendeschneidplatte
for Indexable insert

Typ S274
Type

R = rechts wie gezeichnet
R = right hand version shown

L = links spiegelbildlich
L = left hand version

Bestellnummer Part number	t _{max}	b	f ₂	D _{max}	l ₁	h	h ₁	l _k	Spannbereich Clamping range
R/LNK274.0220.4.04.IK	6	15,8	16	150	48	41,4	31,65	29	4

Ausführung R oder L angeben
State R or L version

Abmessungen in mm
Dimensions in mm

Bestellhinweis:

Befestigungsschrauben der Kassetten gehören zum Lieferumfang des Grundhalters.

Ordering note:

The fastening screw is combined with the basic toolholder - no separate order required.

Das Anzugsdrehmoment der Schrauben finden Sie in den Technischen Hinweisen.

For torque specification of the screw, please see Technical Instructions.

Kühlmittelaustritt:

Durch Spannfinger und Unterstützung

Coolant outlet:

Through clamping finger and insert support

Ersatzteile

Spare Parts

Kassette Cassette	Gewindestift Threaded Pin	Spannschraube Clamping Screw	TORX PLUS®-Schlüssel TORX PLUS® Wrench
R/LNK274.0220.4.04.IK	3.03.913	030.3509.T15P	T15PQ

Einstecken (außen)

Grooving (external)



Kassette

Cassette

NK34T

mit innerer Kühlmittelzufuhr
with through coolant supply

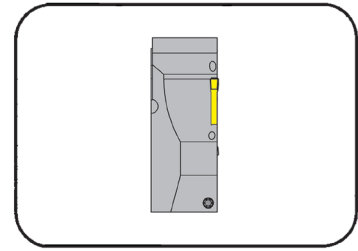

Stechtiefe bis Depth of groove up to 3 mm

für Wendeschneidplatte
for Indexable insert

Typ S34T
Type

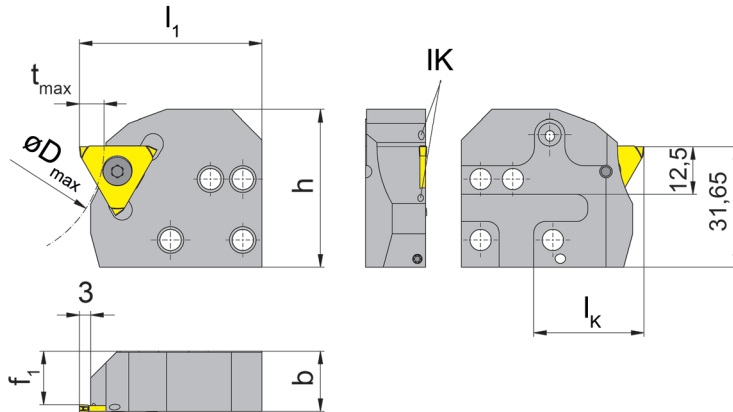

R = rechts wie gezeichnet
R = right hand version shown

L = links spiegelbildlich
L = left hand version

Bestellnummer Part number	t _{max}	b	f	f ₁	D _{max}	l ₁	h	l _k	Größe Size	Spannbereich Clamping range
R/LNK34T.0220.4.00.IK	6,5	15,8	f ₁ +w+a ₁	15,0	60	48	41,4	29	01	1,03
R/LNK34T.0220.4.10.IK	6,5	15,8	f ₁ +w+a ₁	14,3	60	48	41,4	29	01	2,00
R/LNK34T.0220.4.20.IK	6,5	15,8	f ₁ +w+a ₁	13,3	60	48	41,4	29	02	2,01-3,00
R/LNK34T.0220.4.30.IK	6,5	15,8	f ₁ +w+a ₁	12,3	60	48	41,4	29	03	3,01-4,00

Ausführung R oder L angeben
State R or L version

w, a₁ siehe WSP
w, a₁ see indexable inserts

Abmessungen in mm
Dimensions in mm

Bestellhinweis:

Befestigungsschrauben der Kassetten gehören zum Lieferumfang des Grundhalters.

Ordering note:

The fastening screw is combined with the basic toolholder - no separate order required.

Das Anzugsdrehmoment der Schrauben finden Sie in den Technischen Hinweisen.

For torque specification of the screw, please see Technical Instructions.

Kühlmittelaustritt:

Durch Spannfinger und Unterstützung

Coolant outlet:

Through clamping finger and insert support

Einstecken (außen)

Grooving (external)



Kassette

Cassette

NK360

mit innerer Kühlmittelzufuhr
with through coolant supply

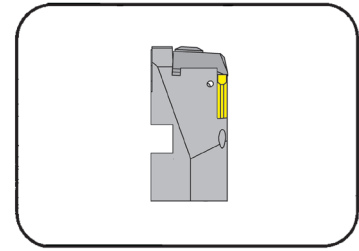

Stechtiefe bis
Spannbereich

Depth of groove up to
Clamping range

6 mm
0,5-6,3 mm

für Wendeschneidplatte
for Indexable insert

Typ 312
Type S312

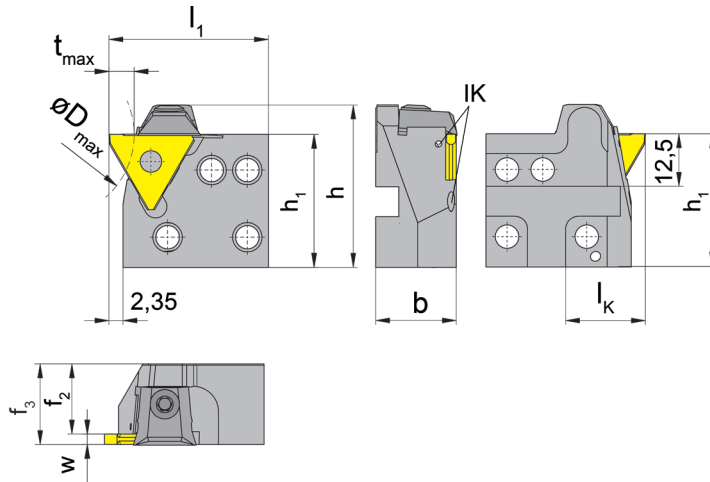

R = rechts wie gezeichnet
R = right hand version shown

L = links spiegelbildlich
L = left hand version

Bestellnummer Part number	t _{max}	b	f ₂	f ₃	D _{max}	l ₁	h	h ₁	l _k	Größe Size	Spannbereich Clamping range
R/LNK360.0220.5.01.IK	4	19,2	17,7	f ₂ +w-a ₁	40	38	38,65	31,65	19	01	0,5-1,9
R/LNK360.0220.5.02.IK	6	19,2	16,7	f ₂ +w-a ₁	40	38	38,65	31,65	19	02	1,9-2,9
R/LNK360.0220.5.03.IK	6	19,2	15,7	f ₂ +w-a ₁	40	38	38,65	31,65	19	03	2,9-3,9
R/LNK360.0220.5.04.IK	6	19,2	14,0	f ₂ +w-a ₁	40	38	38,65	31,65	19	04	3,9-6,3

Ausführung R oder L angeben
State R or L version

w, a₁ siehe WSP
w, a₁ see indexable inserts

Abmessungen in mm
Dimensions in mm

Bestellhinweis:

Befestigungsschrauben der Kassetten gehören zum Lieferumfang des Grundhalters.

Ordering note:

The fastening screw is combined with the basic toolholder - no separate order required.

Das Anzugsdrehmoment der Schrauben finden Sie in den Technischen Hinweisen.

For torque specification of the screw, please see Technical Instructions.

Kühlmittelaustritt:

Durch Unterstützung

Coolant outlet:

Through insert support

Einstecken (außen)

Grooving (external)



Kassette

Cassette

NK368

mit innerer Kühlmittelzufuhr
with through coolant supply

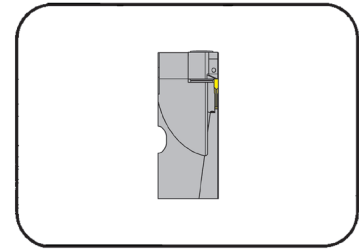

Stechtiefe bis
Spannbereich

Depth of groove up to
Clamping range

8 mm
0,5-1,5 mm

für Wendeschneidplatte
for Indexable insert

Typ 312
Type S312

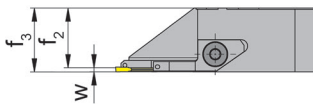
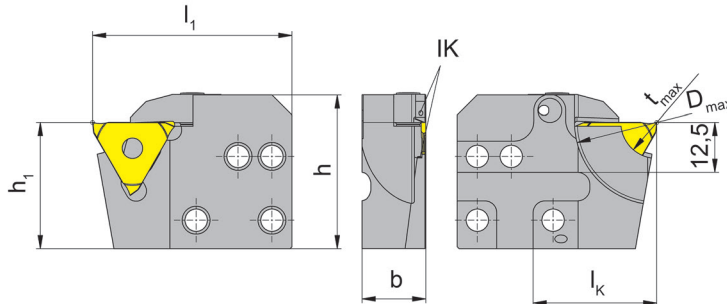

R = rechts wie gezeichnet
R = right hand version shown

L = links spiegelbildlich
L = left hand version

Bestellnummer Part number	t _{max}	b	f ₂	f ₃	D _{max}	h	h ₁	l _K	Größe Size	Spannbereich Clamping range
R/LNK368.0220.4.01.IK	8	16	15,0	f ₂ +w-a ₁	40	38,5	31,65	31	01	0,5-1,2
R/LNK368.0220.4.02.IK	8	16	14,7	f ₂ +w-a ₁	40	38,5	31,65	31	02	1,2-1,5

Ausführung R oder L angeben
State R or L version

w, a₁ siehe WSP
w, a₁ see indexable inserts

Abmessungen in mm
Dimensions in mm

Bestellhinweis:

Befestigungsschrauben der Kassetten gehören zum Lieferumfang des Grundhalters.

Ordering note:

The fastening screw is combined with the basic toolholder - no separate order required.

Das Anzugsdrehmoment der Schrauben finden Sie in den Technischen Hinweisen.

For torque specification of the screw, please see Technical Instructions.

Kühlmittelaustritt:

Durch Spannfinger und Unterstützung

Coolant outlet:

Through clamping finger and insert support

Ersatzteile

Spare Parts

Kassette Cassette	Spannelement Clamping element	TORX PLUS®-Schlüssel TORX PLUS® Wrench
R/LNK368...	010.0004.0586	T10PL

Einstecken (außen)

Grooving (external)



Kassette

Cassette

NK356

mit innerer Kühlmittelzufuhr
with through coolant supply

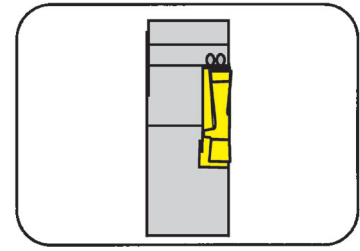

Stechtiefe bis	Depth of groove up to	6 mm
----------------	-----------------------	------

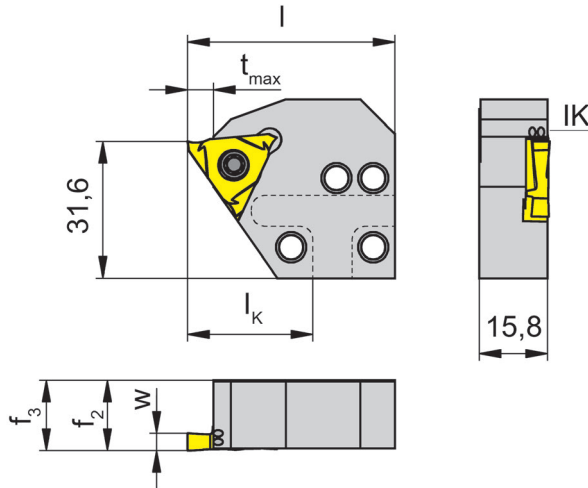

für Wendeschneidplatte
for Indexable insert

Typ 315
Type S315

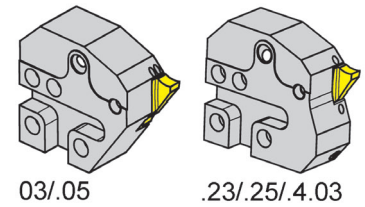

R = rechts wie gezeichnet
R = right hand version shown

L = links spiegelbildlich
L = left hand version

Bestellnummer Part number	t _{max}	f ₂	f ₃	D _{max}	l	l _k	Größe Size
R/LNK356.0220.03.IK	5	16,1	f ₃ =f ₂	-	48	29	03
R/LNK356.0220.05.IK	5	16,3	f ₃ =f ₂	-	48	29	05
R/LNK356.0220.4.23.IK	5	16,3	f ₃ =f ₂	150	48	29	03
R/LNK356.0220.4.25.IK	5	16,3	f ₃ =f ₂	150	48	29	05
R/LNK356.0220.S.4.03.IK	6	16,1	f ₃ =f ₂	150	48	29	03

Ausführung R oder L angeben

State R or L version

Abmessungen in mm

Dimensions in mm

Bestellhinweis:

Befestigungsschrauben der Kassetten gehören zum Lieferumfang des Grundhalters.

Ordering note:

The fastening screw is combined with the basic toolholder - no separate order required.

Das Anzugsdrehmoment der Schrauben finden Sie in den Technischen Hinweisen.

For torque specification of the screw, please see Technical Instructions.

Kühlmittelaustritt:

Durch Spannfinger und Unterstützung

Coolant outlet:

Through clamping finger and insert support

Ersatzteile

Spare Parts

Kassette Cassette	Spannschraube Clamping Screw	TORX PLUS®-Schlüssel TORX PLUS® Wrench	Gewindestift Threaded Pin
R/LNK356.0220...23/24.IK	5.12T20P	T20PQ	
R/LNK356.0220...IK	5.12T20P	T20PQ	3.03.913

Einstecken (außen)

Grooving (external)



Kassette

Cassette

NK316

mit innerer Kühlmittelzufuhr
with through coolant supply

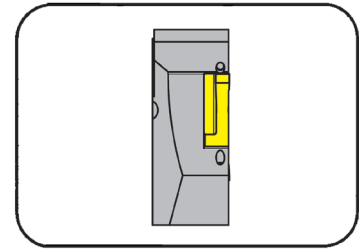

Stechtiefe bis	Depth of groove up to	8 mm
----------------	-----------------------	------

für Wendeschneidplatte
for Indexable insert

Typ S316
Type

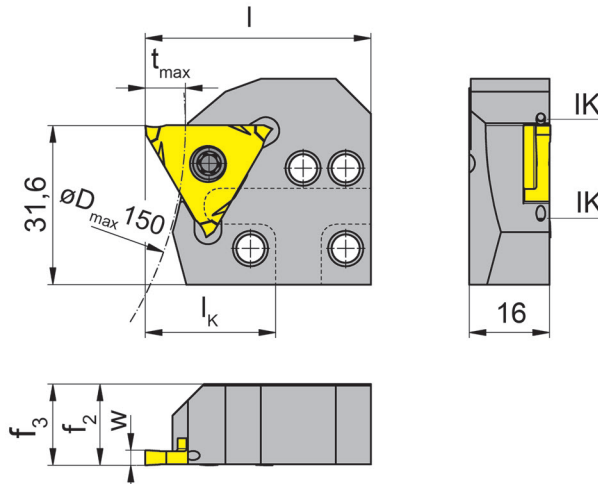

R = rechts wie gezeichnet
R = right hand version shown

L = links spiegelbildlich
L = left hand version

Bestellnummer Part number	t _{max}	f ₂	f ₃	D _{max}	l	l _k	Größe Size
R/LNK316.0220.4.03.IK	8	18,1	f ₃ =f ₂	150	45	26	03
R/LNK316.0220.4.05.IK	8	16,2	f ₃ =f ₂	150	45	26	05
R/LNK316.0220.S3.4.03.IK	8	16,2	f ₃ =f ₂	150	45	26	03

Ausführung R oder L angeben
State R or L version

Abmessungen in mm
Dimensions in mm

Bestellhinweis:

Befestigungsschrauben der Kassetten gehören zum Lieferumfang des Grundhalters.

Ordering note:

The fastening screw is combined with the basic toolholder - no separate order required.

Das Anzugsdrehmoment der Schrauben finden Sie in den Technischen Hinweisen.

For torque specification of the screw, please see Technical Instructions.

Kühlmittelaustritt:

Durch Spannfinger und Unterstüzung

Coolant outlet:

Through clamping finger and insert support

Ersatzteile

Spare Parts

Kassette Cassette	Spannschraube Clamping Screw	TORX PLUS®-Schlüssel TORX PLUS® Wrench
R/LNK316...	5.12T20P	T20PQ

Einstecken (außen)

Grooving (external)



Kassette

Cassette

NK64T

mit innerer Kühlmittelzufuhr
with through coolant supply

Stechtiefe bis	Depth of groove up to	5,5 mm
----------------	-----------------------	--------

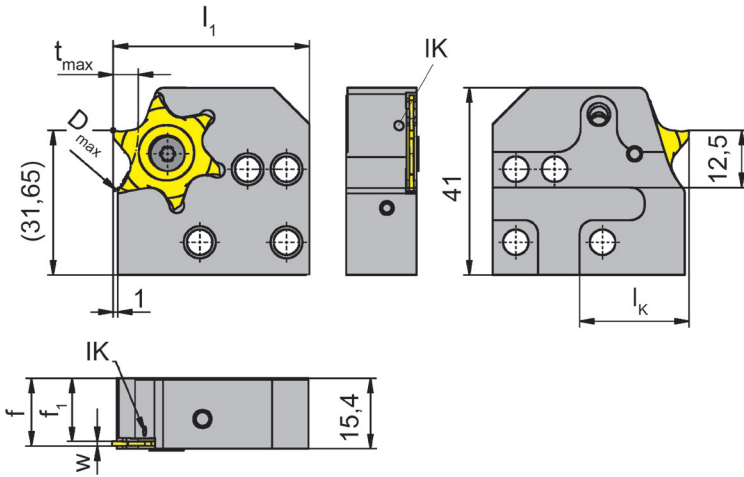
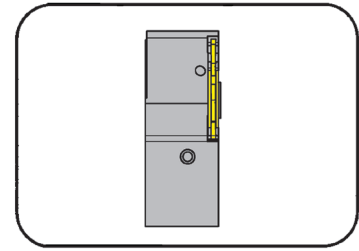

für Wendeschneidplatte
for Indexable insert

Typ S64T
Type

Ein- und Abstechen von Wellen
Grooving and parting off

D_{max}	t_{max}
40	5,5
45	5,0
50	4,5
55	4,0
65	3,5
70	3,5
80	3,0
100	2,5

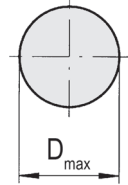

R = rechts wie gezeichnet
R = right hand version shown

L = links spiegelbildlich
L = left hand version

Bestellnummer Part number	t_{max}	f	f_1	D_{max}	l_1	l_k	Größe Size
R/LNK64T.0220.01.IK	5,5	$f_1 + w + a_1$	13,2	100	43	24	01
R/LNK64T.0220.02.IK	5,5	$f_1 + w + a_1$	12,7	100	43	24	02

Ausführung R oder L angeben
State R or L version

w, a_1 siehe WSP
w, a_1 see indexable inserts

Abmessungen in mm
Dimensions in mm

Bestellhinweis:

Befestigungsschrauben der Kassetten gehören zum Lieferumfang des Grundhalters.

Ordering note:

The fastening screw is combined with the basic toolholder - no separate order required.

Das Anzugsdrehmoment der Schrauben finden Sie in den Technischen Hinweisen.

For torque specification of the screw, please see Technical Instructions.

Kühlmittelaustritt:

Seitlich der Schneidplatte

Coolant outlet:

At the side of the insert

Ersatzteile

Spare Parts

Kassette Cassette	Spannschraube Clamping Screw	TORX PLUS®-Schlüssel TORX PLUS® Wrench
R/LNK64T...	030.4010 T15P	T15PQ

Kassette
Cassette
K25A/LAK224/
RAK224/LIK224/
RIK224/LIK220/
RIK220/LAK220/
RAK220

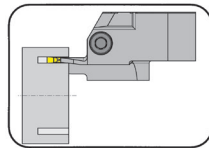

Seite/Page
38

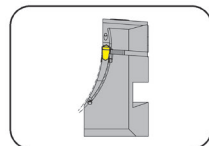

Seite/Page
39-46, 55-60

Technische Hinweise
Technical Information

Seite/Page
63-65

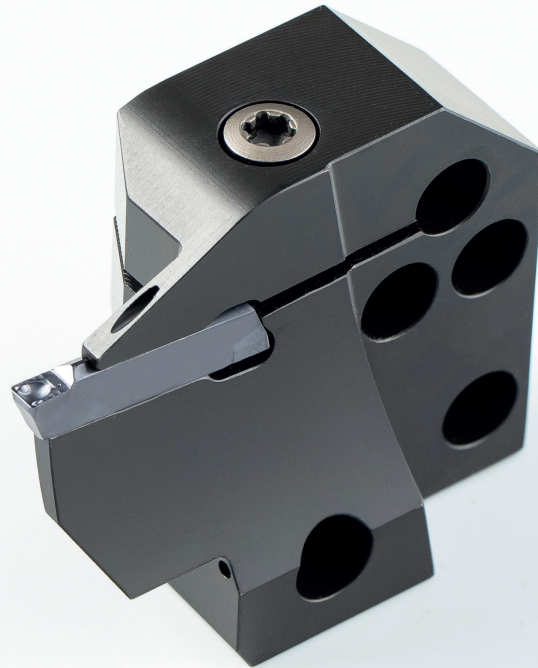

**Kassetten zur
Axialbearbeitung**

mit innerer Kühlmittelzufuhr

**Cassettes for
axial machining**

with through coolant supply

Axialeinstechen

Face Grooving



Kassette

Cassette

K25A

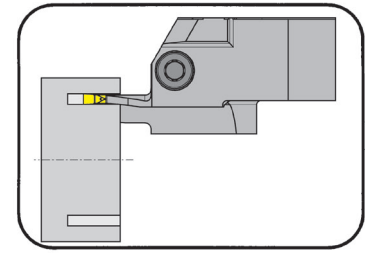

Nutaußen-Ø ab	from outer groove Ø	15 mm
Stechtiefe bis	Depth of groove up to	20 mm
Stechbreite	Width of groove	2-4 mm

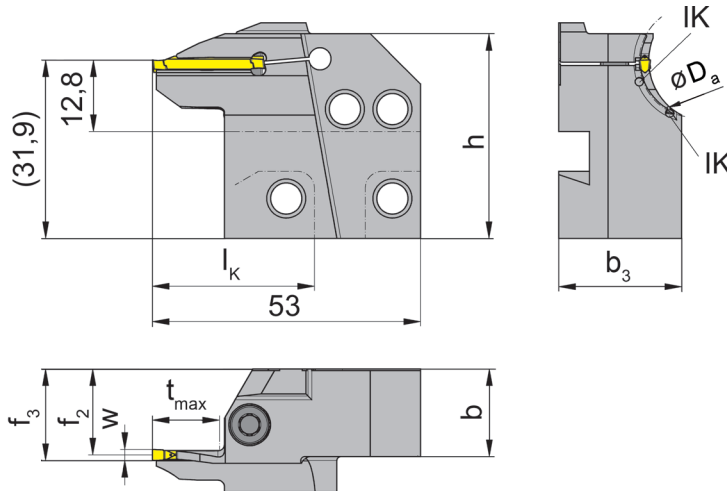

für Wendeschneidplatte
for Indexable insert

Typ S15A
Type S25A

R = rechts wie gezeichnet
R = right hand version shown

L = links spiegelbildlich
L = left hand version

Spitzenhöhe liegt 0,3 mm
über Drehmitte
The cutting edge is above 0,3
mm the centre height

Bestellnummer Part number	D _{a min}	D _{a max}	t _{max}	b	b ₃	f ₂	f ₃	h	l _k	Größe Size
R/LAK25A.1520.02.IK	15	20	12	15,7	21	15,4	f ₂ +w/2	38,6	34	02
R/LAK25A.2025.02.IK	20	25	12	15,7	22	15,4	f ₂ +w/2	38,6	34	02
R/LAK25A.2530.02.IK	25	30	13	15,7	23	15,4	f ₂ +w/2	38,6	34	02
R/LAK25A.2025.03.IK	20	25	14	15,7	24	14,9	f ₂ +w/2	38,6	34	03
R/LAK25A.2530.03.IK	25	30	15	15,7	25	14,9	f ₂ +w/2	38,6	34	03
R/LAK25A.3040.03.IK	30	40	16	15,7	23	14,9	f ₂ +w/2	38,6	34	03
R/LAK25A.4050.03.IK	40	50	18	15,7	24	14,9	f ₂ +w/2	38,6	34	03
R/LAK25A.2025.04.IK	20	25	16	15,7	24	15,1	f ₂ +w/2	38,6	34	04
R/LAK25A.2530.04.IK	25	30	17	15,7	24	15,1	f ₂ +w/2	38,6	34	04
R/LAK25A.3040.04.IK	30	40	18	15,7	24	15,1	f ₂ +w/2	38,6	34	04
R/LAK25A.4050.04.IK	40	50	20	15,7	24	15,1	f ₂ +w/2	39,2	34	04

Weitere Abmessungen auf Anfrage
Further sizes upon request

w siehe WSP
w see indexable inserts

Abmessungen in mm
Dimensions in mm

Das Anzugsdrehmoment der Schraube für w = 2,0 mm ist 2,5 Nm
Das Anzugsdrehmoment der Schraube für w = 3,0 mm ist 3,0 Nm
Das Anzugsdrehmoment der Schraube für w = 4,0 mm ist 3,5 Nm
Torque specification of the screw for w = 2,0 mm is 2,5 Nm
Torque specification of the screw for w = 3,0 mm is 3,0 Nm
Torque specification of the screw for w = 4,0 mm is 3,5 Nm

Hinweis:

für Kassettensitz System 220!

Note:

for use with pocket seat system 220!

Ausführung R oder L angeben

State R or L version

Ersatzteile

Spare Parts

Kassette Cassette	Spannschraube Clamping Screw	TORX PLUS®-Schlüssel TORX PLUS® Wrench
R/LAK25A...	5.13 T20P	T20PQ

Axialeinstechen

Face Grooving



Kassette

Cassette

LAK224

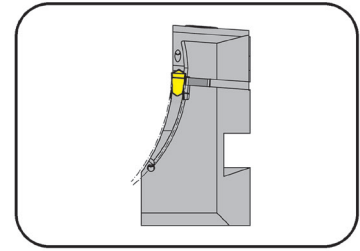

Nutaußen-Ø	Outer groove Ø	38-1000 mm
Stechtiefe bis	Depth of groove up to	14 mm
Stechbreite	Width of groove	3-4 mm

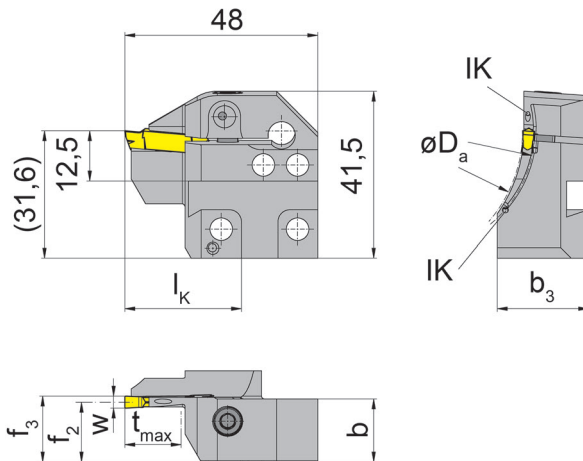

für Wendeschneidplatte
for Indexable insert

Typ S224
Type

L = Linksausführung
L = left hand version

Bestellnummer Part number	D _{a min}	D _{a max}	t _{max}	b	b ₃	f ₂	f ₃	w	l _k
LAK224.5060.03.IK	50	60	14	15,7	23,7	14,9	f ₂ +w/2	3	29
LAK224.6075.03.IK	60	75	14	15,7	22,7	14,9	f ₂ +w/2	3	29
LAK224.7590.03.IK	75	90	14	15,7	22,7	14,9	f ₂ +w/2	3	29
LAK224.9011.03.IK	90	110	14	15,7	21,0	14,9	f ₂ +w/2	3	29
LAK224.1113.03.IK	110	130	14	15,7	21,0	14,9	f ₂ +w/2	3	29
LAK224.1318.03.IK	130	180	14	15,7	20,0	14,9	f ₂ +w/2	3	29
LAK224.1830.03.IK	180	300	14	15,7	19,0	14,9	f ₂ +w/2	3	29
LAK224.3000.03.IK	300	1000	14	15,7	16,9	14,9	f ₂ +w/2	3	29
LAK224.3847.04.IK	38	47	14	15,7	24,2	14,4	f ₂ +w/2	4	29
LAK224.4760.04.IK	47	60	14	15,7	23,7	14,4	f ₂ +w/2	4	29
LAK224.6075.04.IK	60	75	14	15,7	23,7	14,4	f ₂ +w/2	4	29
LAK224.7590.04.IK	75	90	14	15,7	22,7	14,4	f ₂ +w/2	4	29
LAK224.9013.04.IK	90	130	14	15,7	21,0	14,4	f ₂ +w/2	4	29
LAK224.1318.04.IK	130	180	14	15,7	21,0	14,4	f ₂ +w/2	4	29
LAK224.1830.04.IK	180	300	14	15,7	19,0	14,4	f ₂ +w/2	4	29
LAK224.3000.04.IK	300	1000	14	15,7	16,7	14,4	f ₂ +w/2	4	29

Weitere Abmessungen auf Anfrage
Further sizes upon request

Abmessungen in mm
Dimensions in mm

Bestellhinweis:

Befestigungsschrauben der Kassetten gehören zum Lieferumfang des Grundhalters.

Ordering note:

The fastening screw is combined with the basic toolholder - no separate order required.

Das Anzugsdrehmoment der Schrauben finden Sie in den Technischen Hinweisen.

For torque specification of the screw, please see Technical Instructions.

Ersatzteile

Spare Parts

Kassette Cassette	Spannschraube Clamping Screw	TORX PLUS®-Schlüssel TORX PLUS® Wrench
LAK224...	5.13 T20P	T20PQ

Axialeinstechen

Face Grooving



Kassette

Cassette

LAK224

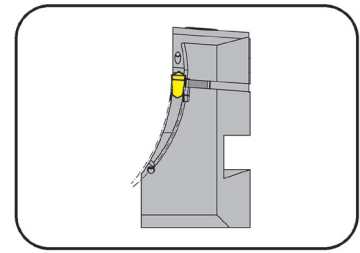

Nutaußen-Ø	Outer groove Ø	38-1000 mm
Stechtiefe bis	Depth of groove up to	14 mm
Stechbreite	Width of groove	5-6 mm

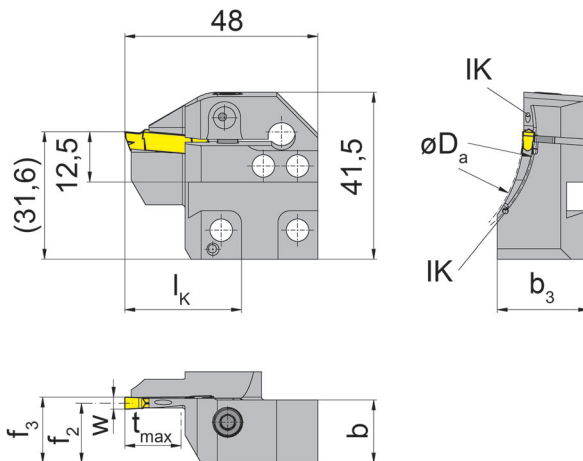

für Wendeschneidplatte
for Indexable insert

Typ S224
Type

L = Linksausführung
L = left hand version

Bestellnummer Part number	D _{a min}	D _{a max}	t _{max}	b	b ₃	f ₂	f ₃	w	l _k
LAK224.3847.05.IK	38	47	14	15,7	23,7	13,9	f ₂ +w/2	5	29
LAK224.4760.05.IK	47	60	14	15,7	23,7	13,9	f ₂ +w/2	5	29
LAK224.6075.05.IK	60	75	14	15,7	23,7	13,9	f ₂ +w/2	5	29
LAK224.7590.05.IK	75	90	14	15,7	22,0	13,9	f ₂ +w/2	5	29
LAK224.9013.05.IK	90	130	14	15,7	22,0	13,9	f ₂ +w/2	5	29
LAK224.1318.05.IK	130	180	14	15,7	21,0	13,9	f ₂ +w/2	5	29
LAK224.1830.05.IK	180	300	14	15,7	19,0	13,9	f ₂ +w/2	5	29
LAK224.3000.05.IK	300	1000	14	15,7	16,7	13,9	f ₂ +w/2	5	29
LAK224.6075.06.IK	60	75	14	15,7	23,0	13,4	f ₂ +w/2	6	29
LAK224.7590.06.IK	75	90	14	15,7	23,0	13,4	f ₂ +w/2	6	29
LAK224.9013.06.IK	90	130	14	15,7	21,0	13,4	f ₂ +w/2	6	29
LAK224.1318.06.IK	130	180	14	15,7	21,0	13,4	f ₂ +w/2	6	29
LAK224.1830.06.IK	180	300	14	15,7	19,0	13,4	f ₂ +w/2	6	29
LAK224.3000.06.IK	300	1000	14	15,7	16,7	13,4	f ₂ +w/2	6	29

Weitere Abmessungen auf Anfrage
Further sizes upon request

Abmessungen in mm
Dimensions in mm

Bestellhinweis:

Befestigungsschrauben der Kassetten gehören zum Lieferumfang des Grundhalters.

Ordering note:

The fastening screw is combined with the basic toolholder - no separate order required.

Das Anzugsdrehmoment der Schrauben finden Sie in den Technischen Hinweisen.

For torque specification of the screw, please see Technical Instructions.

Ersatzteile

Spare Parts

Kassette Cassette	Spannschraube Clamping Screw	TORX PLUS®-Schlüssel TORX PLUS® Wrench
LAK224...	5.13 T20P	T20PQ

Axialeinstechen

Face Grooving



Kassette

Cassette

RAK224

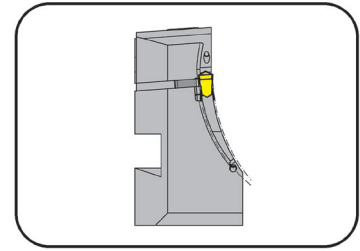

Nutaußen-Ø	Outer groove Ø	38-1000 mm
Stechtiefe bis	Depth of groove up to	14 mm
Stechbreite	Width of groove	3-4 mm

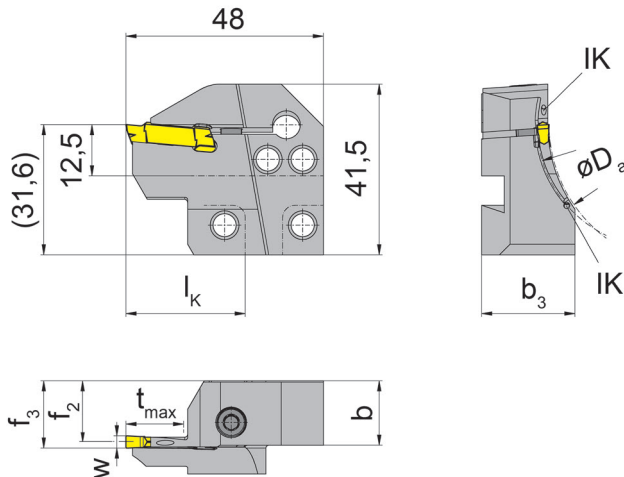

für Wendeschneidplatte
for Indexable insert

Typ S224
Type

R = Rechtsausführung
R = right hand version

Bestellnummer Part number	D _{a min}	D _{a max}	t _{max}	b	b ₃	f ₂	f ₃	w	l _K
RAK224.5060.03.IK	50	60	14	15,7	23,7	14,9	f ₂ +w/2	3	29
RAK224.6075.03.IK	60	75	14	15,7	22,7	14,9	f ₂ +w/2	3	29
RAK224.7590.03.IK	75	90	14	15,7	22,7	14,9	f ₂ +w/2	3	29
RAK224.9011.03.IK	90	110	14	15,7	21,0	14,9	f ₂ +w/2	3	29
RAK224.1113.03.IK	110	130	14	15,7	21,0	14,9	f ₂ +w/2	3	29
RAK224.1318.03.IK	130	180	14	15,7	20,0	14,9	f ₂ +w/2	3	29
RAK224.1830.03.IK	180	300	14	15,7	19,0	14,9	f ₂ +w/2	3	29
RAK224.3000.03.IK	300	1000	14	15,7	16,9	14,9	f ₂ +w/2	3	29
RAK224.3847.04.IK	38	47	14	15,7	24,2	14,4	f ₂ +w/2	4	29
RAK224.4760.04.IK	47	60	14	15,7	23,7	14,4	f ₂ +w/2	4	29
RAK224.6075.04.IK	60	75	14	15,7	23,7	14,4	f ₂ +w/2	4	29
RAK224.7590.04.IK	75	90	14	15,7	22,7	14,4	f ₂ +w/2	4	29
RAK224.9013.04.IK	90	130	14	15,7	21,0	14,4	f ₂ +w/2	4	29
RAK224.1318.04.IK	130	180	14	15,7	21,0	14,4	f ₂ +w/2	4	29
RAK224.1830.04.IK	180	300	14	15,7	19,0	14,4	f ₂ +w/2	4	29
RAK224.3000.04.IK	300	1000	14	15,7	16,7	14,4	f ₂ +w/2	4	29

Weitere Abmessungen auf Anfrage
Further sizes upon request

Abmessungen in mm
Dimensions in mm

Bestellhinweis:

Befestigungsschrauben der Kassetten gehören zum Lieferumfang des Grundhalters.

Ordering note:

The fastening screw is combined with the basic toolholder - no separate order required.

Das Anzugsdrehmoment der Schrauben finden Sie in den Technischen Hinweisen.

For torque specification of the screw, please see Technical Instructions.

Ersatzteile

Spare Parts

Kassette Cassette	Spannschraube Clamping Screw	TORX PLUS®-Schlüssel TORX PLUS® Wrench
RAK224...	5.13 T20P	T20PQ

Axialeinstechen

Face Grooving



Kassette

Cassette

RAK224

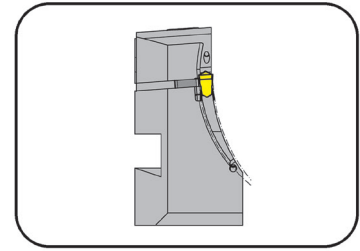

Nutaußen-Ø	Outer groove Ø	38-1000 mm
Stechtiefe bis	Depth of groove up to	14 mm
Stechbreite	Width of groove	5-6 mm

für Wendeschneidplatte
for Indexable insert

Typ S224
Type

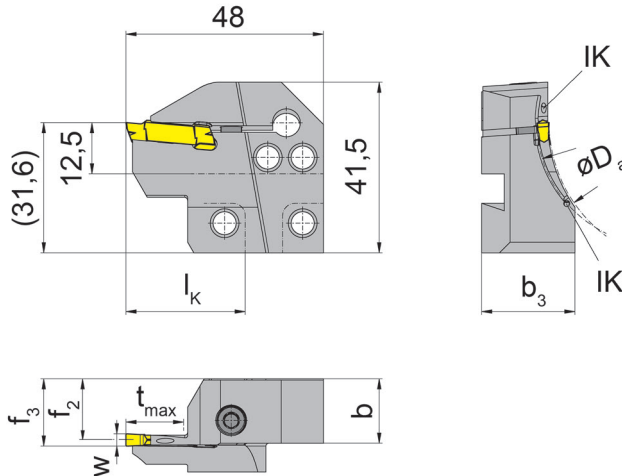

R = Rechtsausführung
R = right hand version

Bestellnummer Part number	D _{a min}	D _{a max}	t _{max}	b	b ₃	f ₂	f ₃	w	l _k
RAK224.3847.05.IK	38	47	14	15,7	23,7	13,9	f ₂ +w/2	5	29
RAK224.4760.05.IK	47	60	14	15,7	23,7	13,9	f ₂ +w/2	5	29
RAK224.6075.05.IK	60	75	14	15,7	23,7	13,9	f ₂ +w/2	5	29
RAK224.7590.05.IK	75	90	14	15,7	22,0	13,9	f ₂ +w/2	5	29
RAK224.9013.05.IK	90	130	14	15,7	22,0	13,9	f ₂ +w/2	5	29
RAK224.1318.05.IK	130	180	14	15,7	21,0	13,9	f ₂ +w/2	5	29
RAK224.1830.05.IK	180	300	14	15,7	19,0	13,9	f ₂ +w/2	5	29
RAK224.3000.05.IK	300	1000	14	15,7	16,7	13,9	f ₂ +w/2	5	29
RAK224.6075.06.IK	60	75	14	15,7	23,0	13,4	f ₂ +w/2	6	29
RAK224.7590.06.IK	75	90	14	15,7	23,0	13,4	f ₂ +w/2	6	29
RAK224.9013.06.IK	90	130	14	15,7	21,0	13,4	f ₂ +w/2	6	29
RAK224.1318.06.IK	130	180	14	15,7	21,0	13,4	f ₂ +w/2	6	29
RAK224.1830.06.IK	180	300	14	15,7	19,0	13,4	f ₂ +w/2	6	29
RAK224.3000.06.IK	300	1000	14	15,7	16,7	13,4	f ₂ +w/2	6	29

Weitere Abmessungen auf Anfrage
Further sizes upon request

Abmessungen in mm
Dimensions in mm

Bestellhinweis:

Befestigungsschrauben der Kassetten gehören zum Lieferumfang des Grundhalters.

Ordering note:

The fastening screw is combined with the basic toolholder - no separate order required.

Das Anzugsdrehmoment der Schrauben finden Sie in den Technischen Hinweisen.

For torque specification of the screw, please see Technical Instructions.

Ersatzteile

Spare Parts

Kassette Cassette	Spannschraube Clamping Screw	TORX PLUS®-Schlüssel TORX PLUS® Wrench
RAK224...	5.13 T20P	T20PQ

Axialeinstechen

Face Grooving



Kassette

Cassette

LIK224

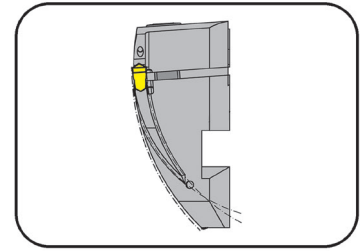

Nutaußen-Ø	Outer groove Ø	38-1000 mm
Stechtiefe bis	Depth of groove up to	14 mm
Stechbreite	Width of groove	3-4 mm

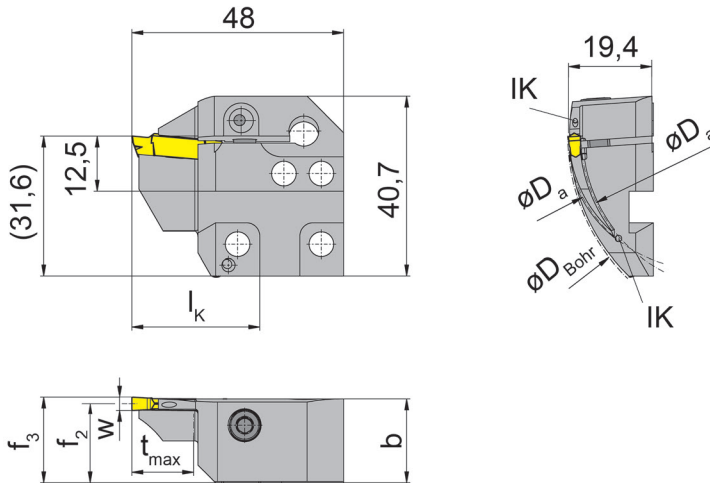

für Wendeschneidplatte
for Indexable insert

Typ S224
Type

L = Linksausführung
L = left hand version

Bestellnummer Part number	D _{Bohr}	D _{a min}	D _{a max}	t _{max}	b	f ₂	f ₃	w	l _k
LIK224.5060.03.IK	90	50	60	14	19	17,9	f ₂ +w/2	3	29
LIK224.6075.03.IK	90	60	75	14	19	17,9	f ₂ +w/2	3	29
LIK224.7590.03.IK	90	75	90	14	19	17,9	f ₂ +w/2	3	29
LIK224.9011.03.IK	90	90	110	14	19	17,9	f ₂ +w/2	3	29
LIK224.1113.03.IK	110	110	130	14	19	17,9	f ₂ +w/2	3	29
LIK224.1318.03.IK	130	130	180	14	19	17,9	f ₂ +w/2	3	29
LIK224.1830.03.IK	180	180	300	14	19	17,9	f ₂ +w/2	3	29
LIK224.3847.04.IK	90	38	47	14	19	17,4	f ₂ +w/2	4	29
LIK224.4760.04.IK	90	47	60	14	19	17,4	f ₂ +w/2	4	29
LIK224.6075.04.IK	90	60	75	14	19	17,4	f ₂ +w/2	4	29
LIK224.7590.04.IK	90	75	90	14	19	17,4	f ₂ +w/2	4	29
LIK224.9013.04.IK	90	90	130	14	19	17,4	f ₂ +w/2	4	29
LIK224.1318.04.IK	130	130	180	14	19	17,4	f ₂ +w/2	4	29
LIK224.3000.04.IK	300	300	1000	14	19	17,4	f ₂ +w/2	4	29

Weitere Abmessungen auf Anfrage
Further sizes upon request

Abmessungen in mm
Dimensions in mm

Bestellhinweis:

Befestigungsschrauben der Kassetten gehören zum Lieferumfang des Grundhalters.

Ordering note:

The fastening screw is combined with the basic toolholder - no separate order required.

Das Anzugsdrehmoment der Schrauben finden Sie in den Technischen Hinweisen.

For torque specification of the screw, please see Technical Instructions.

Ersatzteile

Spare Parts

Kassette Cassette	Spannschraube Clamping Screw	TORX PLUS®-Schlüssel TORX PLUS® Wrench
LIK224...	5.13 T20P	T20PQ

Axialeinstechen

Face Grooving



Kassette

Cassette

LIK224

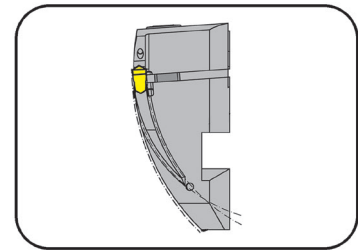

Nutaußen-Ø	Outer groove Ø	38-1000 mm
Stechtiefe bis	Depth of groove up to	14 mm
Stechbreite	Width of groove	5-6 mm

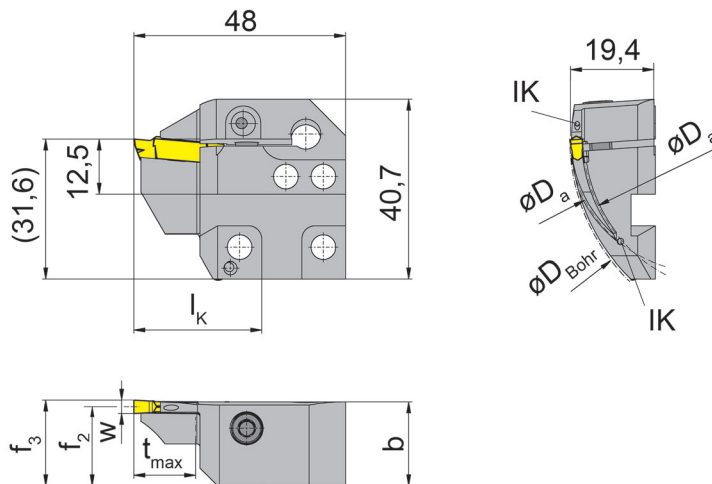

für Wendeschneidplatte
for Indexable insert

Typ S224
Type

L = Linksausführung
L = left hand version

Bestellnummer Part number	D _{Bohr}	D _{a min}	D _{a max}	t _{max}	b	f ₂	f ₃	w	l _k
LIK224.3847.05.IK	90	38	47	14	19,00	16,9	f ₂ +w/2	5	29
LIK224.4760.05.IK	90	47	60	14	19,00	17,4	f ₂ +w/2	5	29
LIK224.6075.05.IK	90	60	75	14	19,00	16,9	f ₂ +w/2	5	29
LIK224.7590.05.IK	90	75	90	14	19,00	16,9	f ₂ +w/2	5	29
LIK224.9013.05.IK	90	90	130	14	19,00	16,9	f ₂ +w/2	5	29
LIK224.1318.05.IK	130	130	180	14	19,00	16,9	f ₂ +w/2	5	29
LIK224.1830.05.IK	180	180	300	14	19,00	16,9	f ₂ +w/2	5	29
LIK224.3000.05.IK	300	300	1000	14	18,90	16,9	f ₂ +w/2	5	29
LIK224.6075.06.IK	90	60	75	14	19,00	16,4	f ₂ +w/2	6	29
LIK224.7590.06.IK	90	75	90	14	19,00	16,4	f ₂ +w/2	6	29
LIK224.9013.06.IK	90	90	130	14	19,00	16,4	f ₂ +w/2	6	29
LIK224.1318.06.IK	130	130	180	14	19,00	16,4	f ₂ +w/2	6	29
LIK224.1830.06.IK	180	180	300	14	19,00	16,4	f ₂ +w/2	6	29
LIK224.3000.06.IK	300	300	1000	14	18,75	16,4	f ₂ +w/2	6	29

Weitere Abmessungen auf Anfrage
Further sizes upon request

Abmessungen in mm
Dimensions in mm

Bestellhinweis:

Befestigungsschrauben der Kassetten gehören zum Lieferumfang des Grundhalters.

Ordering note:

The fastening screw is combined with the basic toolholder - no separate order required.

Das Anzugsdrehmoment der Schrauben finden Sie in den Technischen Hinweisen.

For torque specification of the screw, please see Technical Instructions.

Ersatzteile

Spare Parts

Kassette Cassette	Spannschraube Screw	TORX PLUS®-Schlüssel TORX PLUS® Wrench
LIK224...	5.13 T20P	T20PQ

Axialeinstechen

Face Grooving



Kassette

Cassette

RIK224

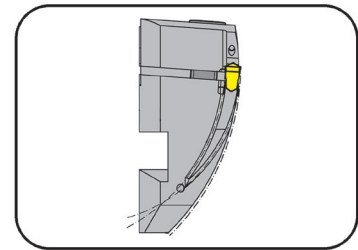

Nutaußen-Ø	Outer groove Ø	38-1000 mm
Stechtiefe bis	Depth of groove up to	14 mm
Stechbreite	Width of groove	3-4 mm

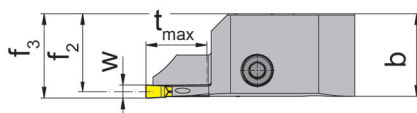
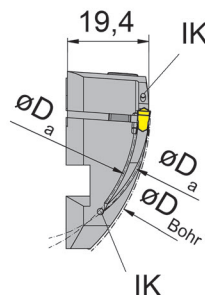
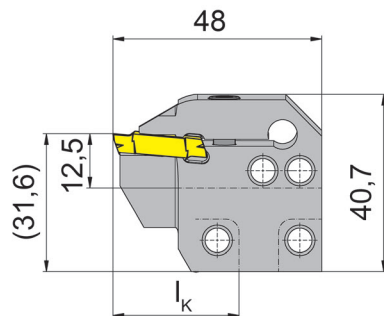

für Wendeschneidplatte
for Indexable insert

Typ S224
Type

R = Rechtsausführung
R = right hand version

Bestellnummer Part number	D _{Bohr}	D _{a min}	D _{a max}	t _{max}	b	f ₂	f ₃	w	l _k
RIK224.5060.03.IK	90	50	60	14	19,00	17,9	f ₂ +w/2	3	29
RIK224.6075.03.IK	90	60	75	14	19,00	17,9	f ₂ +w/2	3	29
RIK224.7590.03.IK	90	75	90	14	19,00	17,9	f ₂ +w/2	3	29
RIK224.9011.03.IK	90	90	110	14	19,00	17,9	f ₂ +w/2	3	29
RIK224.1113.03.IK	110	110	130	14	19,00	17,9	f ₂ +w/2	3	29
RIK224.1318.03.IK	130	130	180	14	19,05	17,9	f ₂ +w/2	3	29
RIK224.1830.03.IK	180	180	300	14	19,00	17,9	f ₂ +w/2	3	29
RIK224.3847.04.IK	90	38	47	14	19,00	17,4	f ₂ +w/2	4	29
RIK224.4760.04.IK	90	47	60	14	19,00	17,4	f ₂ +w/2	4	29
RIK224.6075.04.IK	90	60	75	14	19,00	17,4	f ₂ +w/2	4	29
RIK224.7590.04.IK	90	75	90	14	19,00	17,4	f ₂ +w/2	4	29
RIK224.9013.04.IK	90	90	130	14	19,00	17,4	f ₂ +w/2	4	29
RIK224.1318.04.IK	130	130	180	14	19,00	17,4	f ₂ +w/2	4	29
RIK224.3000.04.IK	300	300	1000	14	19,00	17,4	f ₂ +w/2	4	29

Weitere Abmessungen auf Anfrage
Further sizes upon request

Abmessungen in mm
Dimensions in mm

Bestellhinweis:

Befestigungsschrauben der Kassetten gehören zum Lieferumfang des Grundhalters.

Ordering note:

The fastening screw is combined with the basic toolholder - no separate order required.

Das Anzugsdrehmoment der Schrauben finden Sie in den Technischen Hinweisen.

For torque specification of the screw, please see Technical Instructions.

Ersatzteile

Spare Parts

Kassette Cassette	Spannschraube Screw	TORX PLUS®-Schlüssel TORX PLUS® Wrench
LIK224...	5.13 T20P	T20PQ

Axialeinstechen

Face Grooving



Kassette

Cassette

RIK224

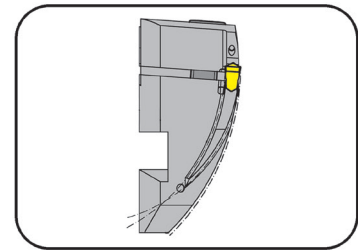

Nutaußen-Ø	Outer groove Ø	38-1000 mm
Stechtiefe bis	Depth of groove up to	14 mm
Stechbreite	Width of groove	5-6 mm

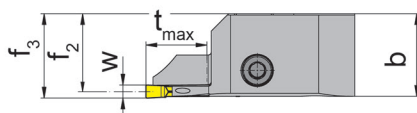
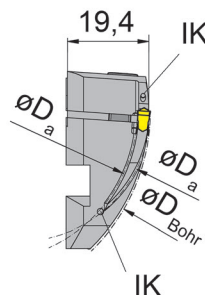
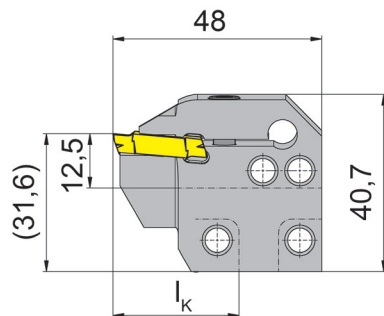

für Wendeschneidplatte
for Indexable insert

Typ S224
Type

R = Rechtsausführung
R = right hand version

Bestellnummer Part number	D _{Bohr}	D _{a min}	D _{a max}	t _{max}	b	f ₂	f ₃	w	l _k
RIK224.3847.05.IK	90	38	47	14	19,00	16,9	f ₂ +w/2	5	29
RIK224.4760.05.IK	90	47	60	14	19,00	17,4	f ₂ +w/2	5	29
RIK224.6075.05.IK	90	60	75	14	19,00	16,9	f ₂ +w/2	5	29
RIK224.7590.05.IK	90	75	90	14	19,00	16,9	f ₂ +w/2	5	29
RIK224.9013.05.IK	90	90	130	14	19,00	16,9	f ₂ +w/2	5	29
RIK224.1318.05.IK	130	130	180	14	19,00	16,9	f ₂ +w/2	5	29
RIK224.1830.05.IK	180	180	300	14	19,00	16,9	f ₂ +w/2	5	29
RIK224.3000.05.IK	300	300	1000	14	18,90	16,9	f ₂ +w/2	5	29
RIK224.6075.06.IK	90	60	75	14	19,00	16,4	f ₂ +w/2	6	29
RIK224.7590.06.IK	90	75	90	14	19,00	16,4	f ₂ +w/2	6	29
RIK224.9013.06.IK	90	90	130	14	19,00	16,4	f ₂ +w/2	6	29
RIK224.1318.06.IK	130	130	180	14	19,00	16,4	f ₂ +w/2	6	29
RIK224.1830.06.IK	180	180	300	14	19,00	16,4	f ₂ +w/2	6	29
RIK224.3000.06.IK	300	300	1000	14	18,75	16,4	f ₂ +w/2	6	29

Weitere Abmessungen auf Anfrage
Further sizes upon request

Abmessungen in mm
Dimensions in mm

Bestellhinweis:

Befestigungsschrauben der Kassetten gehören zum Lieferumfang des Grundhalters.

Ordering note:

The fastening screw is combined with the basic toolholder - no separate order required.

Das Anzugsdrehmoment der Schrauben finden Sie in den Technischen Hinweisen.

For torque specification of the screw, please see Technical Instructions.

Ersatzteile

Spare Parts

Kassette Cassette	Spannschraube Clamping Screw	TORX PLUS®-Schlüssel TORX PLUS® Wrench
RIK224...	5.13 T20P	T20PQ

Axialeinstechen

Face Grooving



Kassette

Cassette

LAK220

mit innerer Kühlmittelzufuhr
with through coolant supply

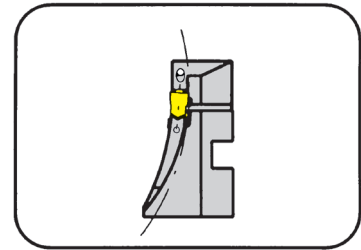

Nutaußen-Ø
Stechtiefe bis
Stechbreite

Outer groove Ø
Depth of groove up to
Width of groove

60-1000 mm
25 mm
4-5 mm

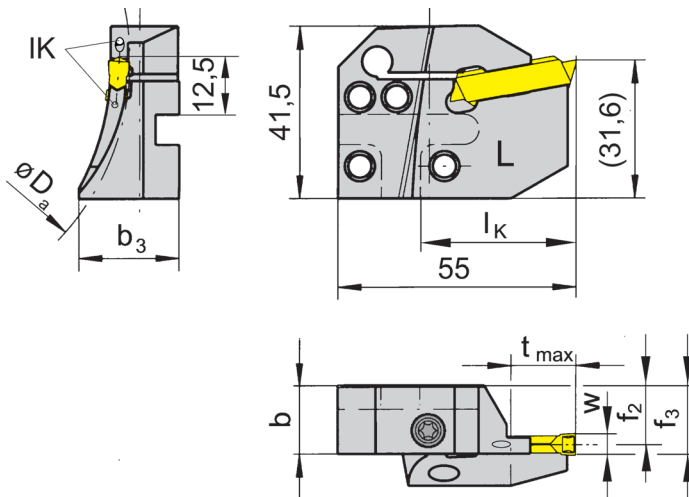

für Wendeschneidplatte
für Indexable insert

Typ 229
Type S229

L = Linksausführung
L = left hand version

Bestellnummer Part number	$D_{a \min}$	$D_{a \max}$	t_{\max}	b	b_3	f_2	f_3	w	l_K
LAK220.6575.04.IK	65	75	10-15	15,7	23,0	14,4	$f_2+w/2$	4	36
LAK220.7595.04.IK	75	95	15-25	15,7	23,0	14,4	$f_2+w/2$	4	36
LAK220.9513.04.IK	95	122	25	15,7	21,2	14,4	$f_2+w/2$	4	36
LAK220.1318.04.IK	130	180	25	15,7	21,2	14,4	$f_2+w/2$	4	36
LAK220.1830.04.IK	180	300	25	15,7	19,0	14,4	$f_2+w/2$	4	36
LAK220.3000.04.IK	300	1000	25	15,7	16,8	14,4	$f_2+w/2$	4	36
LAK220.6075.05.IK	60	75	10-17	15,7	23,0	13,9	$f_2+w/2$	5	36
LAK220.7595.05.IK	75	95	17-25	15,7	23,0	13,9	$f_2+w/2$	5	36
LAK220.9513.05.IK	95	120	25	15,7	23,0	13,9	$f_2+w/2$	5	36
LAK220.1318.05.IK	130	180	25	15,7	21,2	13,9	$f_2+w/2$	5	36
LAK220.1830.05.IK	180	300	25	15,7	19,0	13,9	$f_2+w/2$	5	36
LAK220.3000.05.IK	300	1000	25	15,7	16,8	13,9	$f_2+w/2$	5	36

Weitere Abmessungen auf Anfrage
Further sizes upon request

Abmessungen in mm
Dimensions in mm

Bestellhinweis:

Befestigungsschrauben der Kassetten gehören zum Lieferumfang des Grundhalters.

Ordering note:

The fastening screw is combined with the basic toolholder - no separate order required.

Das Anzugsdrehmoment der Schrauben finden Sie in den Technischen Hinweisen.

For torque specification of the screw, please see Technical Instructions.

Ersatzteile

Spare Parts

Kassette Cassette	Spannschraube Screw	TORX PLUS®-Schlüssel TORX PLUS® Wrench
LAK220...	6.23T25P	T25PQ

Axialeinstechen

Face Grooving



Kassette

Cassette

LAK220

mit innerer Kühlmittelzufuhr
with through coolant supply

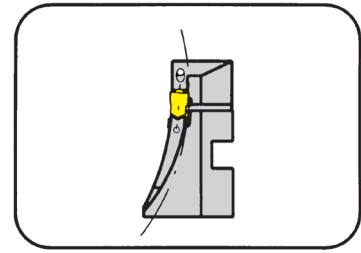

Nutaußen-Ø
Stechtiefe bis
Stechbreite

Outer groove Ø
Depth of groove up to
Width of groove

60-1000 mm
25 mm
6 mm

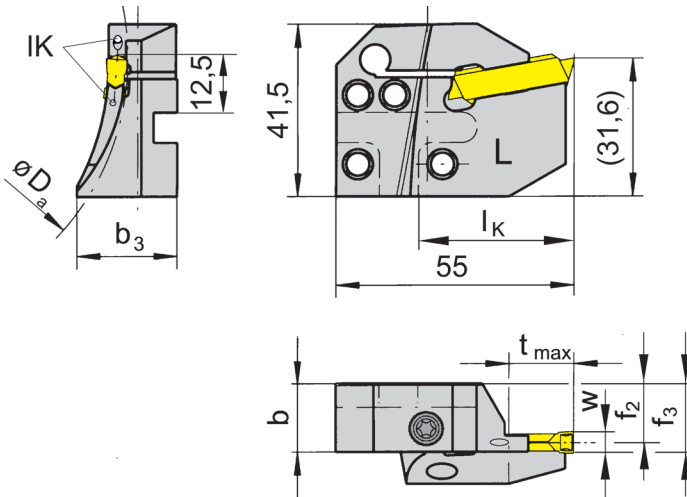

für Wendeschneidplatte
für Indexable insert

Typ 229
Type S229

L = Linksausführung
L = left hand version

Bestellnummer Part number	D _{a min}	D _{a max}	t _{max}	b	b ₃	f ₂	f ₃	w	l _K
LAK220.6075.06.IK	60	75	10-17	15,7	23,0	13,4	f ₂ +w/2	6	36
LAK220.7595.06.IK	75	95	17-25	15,7	23,0	13,4	f ₂ +w/2	6	36
LAK220.9513.06.IK	95	130	25	15,7	23,0	13,4	f ₂ +w/2	6	36
LAK220.1318.06.IK	130	180	25	15,7	21,2	13,4	f ₂ +w/2	6	36
LAK220.1830.06.IK	180	300	25	15,7	19,0	13,4	f ₂ +w/2	6	36
LAK220.3000.06.IK	300	1000	25	15,7	16,8	13,4	f ₂ +w/2	6	36

Weitere Abmessungen auf Anfrage
Further sizes upon request

Abmessungen in mm
Dimensions in mm

Bestellhinweis:

Befestigungsschrauben der Kassetten gehören zum Lieferumfang des Grundhalters.

Ordering note:

The fastening screw is combined with the basic toolholder - no separate order required.

Das Anzugsdrehmoment der Schrauben finden Sie in den Technischen Hinweisen.

For torque specification of the screw, please see Technical Instructions.

Ersatzteile

Spare Parts

Kassette Cassette	Spannschraube Screw	TORX PLUS®-Schlüssel TORX PLUS® Wrench
LAK220...	6.23T25P	T25PQ

Axialeinstechen

Face Grooving



Kassette

Cassette

LAK220

mit innerer Kühlmittelzufuhr
with through coolant supply

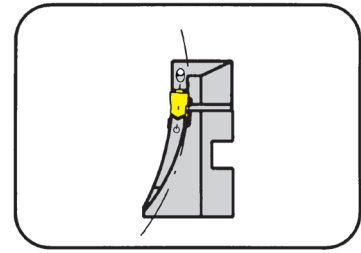

Nutaußen-Ø
Stechtiefe bis
Stechbreite

Outer groove Ø
Depth of groove up to
Width of groove

60-300 mm
15 mm
4-5 mm

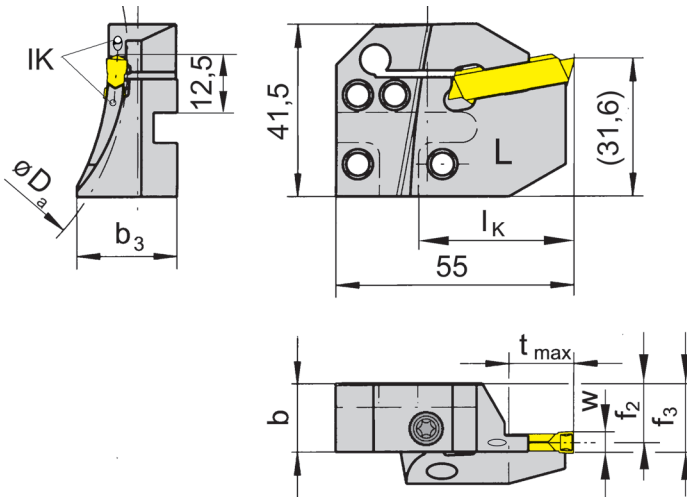

für Wendeschneidplatte
für Indexable insert

Typ 229
Type S229

L = Linksausführung
L = left hand version

Bestellnummer Part number	D _{a min}	D _{a max}	t _{max}	b	b ₃	f ₂	f ₃	w	l _K
LAK220.6575.14.IK	65	75	10	15,7	23,0	14,4	f ₂ +w/2	4	36
LAK220.7595.14.IK	75	95	15	15,7	23,0	14,4	f ₂ +w/2	4	36
LAK220.9513.14.IK	95	130	15	15,7	21,2	14,4	f ₂ +w/2	4	36
LAK220.1318.14.IK	130	180	15	15,7	21,2	14,4	f ₂ +w/2	4	36
LAK220.1830.14.IK	180	300	15	15,7	19,0	14,4	f ₂ +w/2	4	36
LAK220.6075.15.IK	60	75	10	15,7	23,0	13,9	f ₂ +w/2	5	36
LAK220.7595.15.IK	75	95	15	15,7	23,0	13,9	f ₂ +w/2	5	36
LAK220.9513.15.IK	95	130	15	15,7	23,0	13,9	f ₂ +w/2	5	36
LAK220.1318.15.IK	130	180	15	15,7	21,2	13,9	f ₂ +w/2	5	36
LAK220.1830.15.IK	180	300	15	15,7	19,0	13,9	f ₂ +w/2	5	36

Weitere Abmessungen auf Anfrage
Further sizes upon request

Abmessungen in mm
Dimensions in mm

Bestellhinweis:

Befestigungsschrauben der Kassetten gehören zum Lieferumfang des Grundhalters.

Ordering note:

The fastening screw is combined with the basic toolholder - no separate order required.

Das Anzugsdrehmoment der Schrauben finden Sie in den Technischen Hinweisen.

For torque specification of the screw, please see Technical Instructions.

Ersatzteile

Spare Parts

Kassette Cassette	Spannschraube Clamping Screw	TORX PLUS®-Schlüssel TORX PLUS® Wrench
LAK220...	6.23T25P	T25PQ

Axialeinstechen

Face Grooving



Kassette

Cassette

LAK220

mit innerer Kühlmittelzufuhr
with through coolant supply

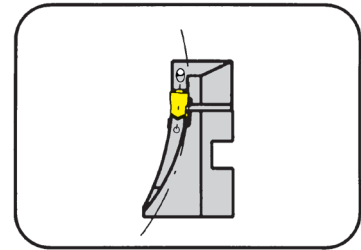

Nutaußen-Ø
Stechtiefe bis
Stechbreite

Outer groove Ø
Depth of groove up to
Width of groove

60-300 mm
15 mm
6 mm

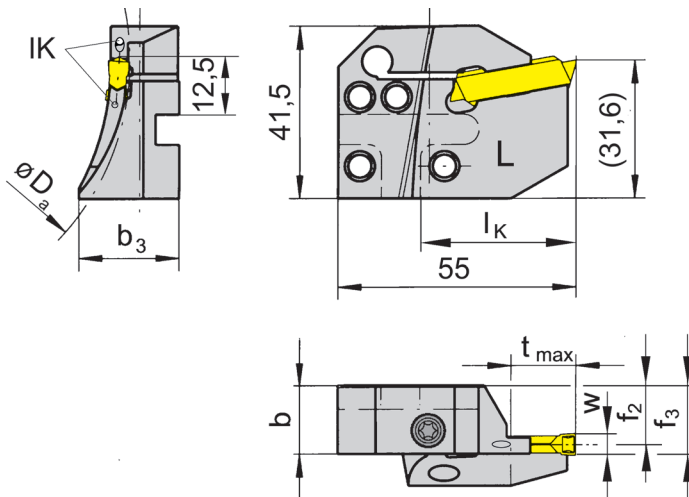

für Wendeschneidplatte
für Indexable insert

Typ 229
Type S229

L = Linksausführung
L = left hand version

Bestellnummer Part number	$D_{a \min}$	$D_{a \max}$	t_{\max}	b	b_3	f_2	f_3	w	l_K
LAK220.6075.16.IK	60	75	10	15,7	23,0	13,4	$f_2+w/2$	6	36
LAK220.7595.16.IK	75	95	15	15,7	23,0	13,4	$f_2+w/2$	6	36
LAK220.9513.16.IK	95	130	15	15,7	23,0	13,4	$f_2+w/2$	6	36
LAK220.1318.16.IK	130	180	15	15,7	21,2	13,4	$f_2+w/2$	6	36
LAK220.1830.16.IK	180	300	15	15,7	19,0	13,4	$f_2+w/2$	6	36

Weitere Abmessungen auf Anfrage
Further sizes upon request

Abmessungen in mm
Dimensions in mm

Bestellhinweis:

Befestigungsschrauben der Kassetten gehören zum Lieferumfang des Grundhalters.

Ordering note:

The fastening screw is combined with the basic toolholder - no separate order required.

Das Anzugsdrehmoment der Schrauben finden Sie in den Technischen Hinweisen.

For torque specification of the screw, please see Technical Instructions.

Ersatzteile

Spare Parts

Kassette Cassette	Gewindestift Threaded Pin	Spannschraube Clamping Screw	TORX PLUS®-Schlüssel TORX PLUS® Wrench
LAK220...	3.03.913	6.23T25P	T25PQ

Axialeinstechen

Face Grooving



Kassette

Cassette

RAK220

mit innerer Kühlmittelzufuhr
with through coolant supply

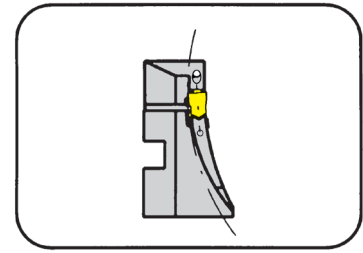

Nutaußen-Ø
Stechtiefe bis
Stechbreite

Outer groove Ø
Depth of groove up to
Width of groove

60-1000 mm
25 mm
4-5 mm

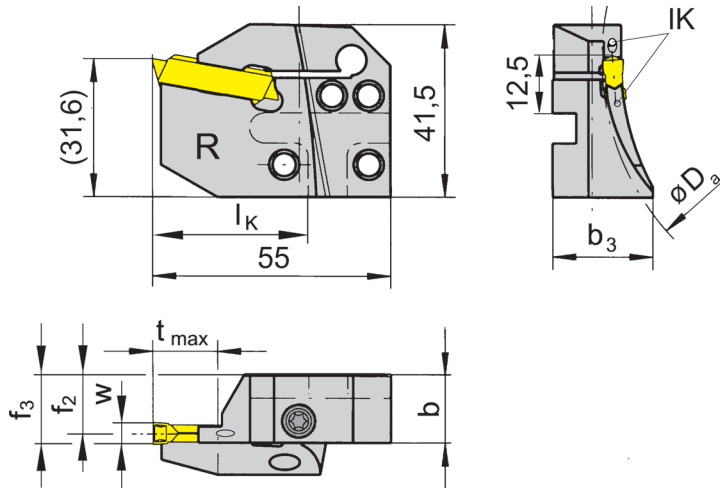

für Wendeschneidplatte
für Indexable insert

Typ 229
Type S229

R = Rechtsausführung
R = right hand version

Bestellnummer Part number	D _{a min}	D _{a max}	t _{max}	b	b ₃	f ₂	f ₃	w	l _k
RAK220.6575.04.IK	65	75	10-15	15,7	23,0	14,4	f ₂ +w/2	4	36
RAK220.7595.04.IK	75	95	15-25	15,7	23,0	14,4	f ₂ +w/2	4	36
RAK220.9513.04.IK	95	130	25	15,7	21,2	14,4	f ₂ +w/2	4	36
RAK220.1318.04.IK	130	180	25	15,7	21,2	14,4	f ₂ +w/2	4	36
RAK220.1830.04.IK	180	300	25	15,7	19,0	14,4	f ₂ +w/2	4	36
RAK220.3000.04.IK	300	1000	25	15,7	16,8	14,4	f ₂ +w/2	4	36
RAK220.6075.05.IK	60	75	10-17	15,7	23,0	13,9	f ₂ +w/2	5	36
RAK220.7595.05.IK	75	95	17-25	15,7	23,0	13,9	f ₂ +w/2	5	36
RAK220.9513.05.IK	95	130	25	15,7	23,0	13,9	f ₂ +w/2	5	36
RAK220.1318.05.IK	130	180	25	15,7	21,2	13,9	f ₂ +w/2	5	36
RAK220.1830.05.IK	180	300	25	15,7	19,0	13,9	f ₂ +w/2	5	36
RAK220.3000.05.IK	300	1000	25	15,7	16,8	13,9	f ₂ +w/2	5	36

Weitere Abmessungen auf Anfrage
Further sizes upon request

Abmessungen in mm
Dimensions in mm

Bestellhinweis:

Befestigungsschrauben der Kassetten gehören zum Lieferumfang des Grundhalters.

Ordering note:

The fastening screw is combined with the basic toolholder - no separate order required.

Das Anzugsdrehmoment der Schrauben finden Sie in den Technischen Hinweisen.

For torque specification of the screw, please see Technical Instructions.

Ersatzteile

Spare Parts

Kassette Cassette	Spannschraube Screw	TORX PLUS®-Schlüssel TORX PLUS® Wrench
RAK220...	6.23T25P	T25PQ

Axialeinstechen

Face Grooving



Kassette

Cassette

RAK220

mit innerer Kühlmittelzufuhr
with through coolant supply

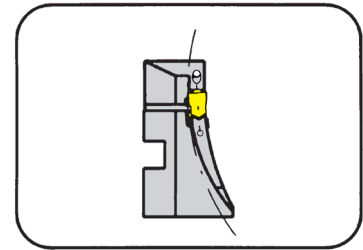

Nutaußen-Ø
Stechtiefe bis
Stechbreite

Outer groove Ø
Depth of groove up to
Width of groove

60-1000 mm
25 mm
6 mm

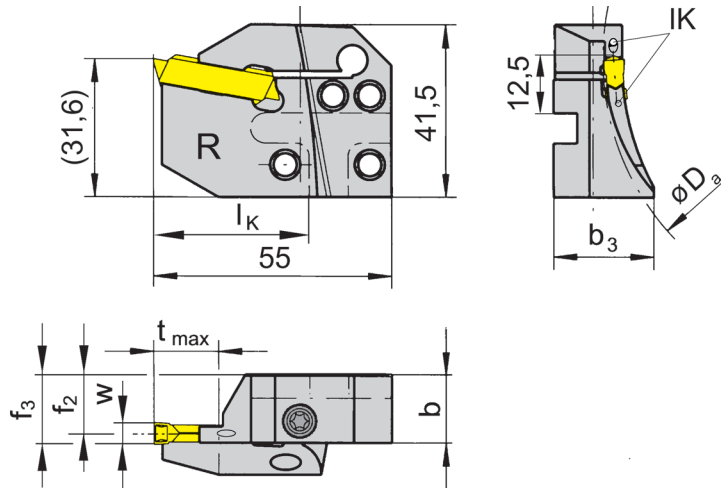

für Wendeschneidplatte
für Indexable insert

Typ 229
Type S229

R = Rechtsausführung
R = right hand version

Bestellnummer Part number	D _{a min}	D _{a max}	t _{max}	b	b ₃	f ₂	f ₃	w	l _k
RAK220.6075.06.IK	60	75	10-17	15,7	23,0	13,4	f ₂ +w/2	6	36
RAK220.7595.06.IK	75	95	17-25	15,7	23,0	13,4	f ₂ +w/2	6	36
RAK220.9513.06.IK	95	130	25	15,7	23,0	13,4	f ₂ +w/2	6	36
RAK220.1318.06.IK	130	180	25	15,7	21,2	13,4	f ₂ +w/2	6	36
RAK220.1830.06.IK	180	300	25	15,7	19,0	13,4	f ₂ +w/2	6	36
RAK220.3000.06.IK	300	1000	25	15,7	16,8	13,4	f ₂ +w/2	6	36

Weitere Abmessungen auf Anfrage
Further sizes upon request

Abmessungen in mm
Dimensions in mm

Bestellhinweis:

Befestigungsschrauben der Kassetten gehören zum Lieferumfang des Grundhalters.

Ordering note:

The fastening screw is combined with the basic toolholder - no separate order required.

Das Anzugsdrehmoment der Schrauben finden Sie in den Technischen Hinweisen.

For torque specification of the screw, please see Technical Instructions.

Ersatzteile

Spare Parts

Kassette Cassette	Spannschraube Screw	TORX PLUS®-Schlüssel TORX PLUS® Wrench
RAK220...	6.23T25P	T25PQ

Axialeinstechen

Face Grooving



Kassette

Cassette

RAK220

mit innerer Kühlmittelzufuhr
with through coolant supply

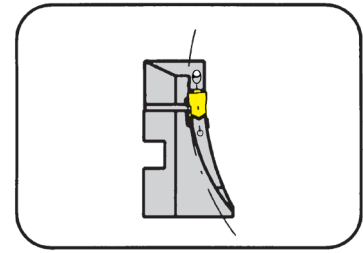

Nutaußen-Ø
Stechtiefe bis
Stechbreite

Outer groove Ø
Depth of groove up to
Width of groove

60-300 mm
15 mm
4-5 mm

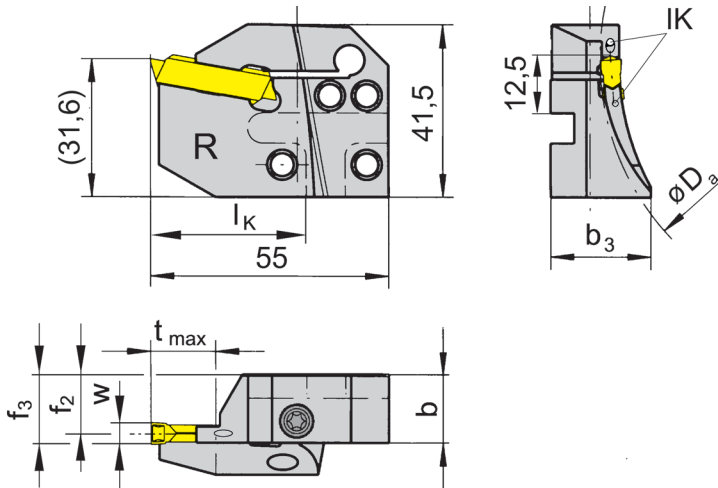

für Wendeschneidplatte
für Indexable insert

Typ 229
Type S229

R = Rechtsausführung
R = right hand version

Bestellnummer Part number	D _{a min}	D _{a max}	t _{max}	b	b ₃	f ₂	f ₃	w	l _k
RAK220.6575.14.IK	65	75	10	15,7	23,0	14,4	f ₂ +w/2	4	36
RAK220.7595.14.IK	75	95	15	15,7	23,0	14,4	f ₂ +w/2	4	36
RAK220.9513.14.IK	95	130	15	15,7	21,2	14,4	f ₂ +w/2	4	36
RAK220.1318.14.IK	130	180	15	15,7	21,2	14,4	f ₂ +w/2	4	36
RAK220.1830.14.IK	180	300	15	15,7	19,0	14,4	f ₂ +w/2	4	36
RAK220.6075.15.IK	60	75	10	15,7	23,0	13,4	f ₂ +w/2	5	36
RAK220.7595.15.IK	75	95	15	15,7	23,0	13,9	f ₂ +w/2	5	36
RAK220.9513.15.IK	95	130	15	15,7	23,0	13,9	f ₂ +w/2	5	36
RAK220.1318.15.IK	130	180	15	15,7	21,2	13,9	f ₂ +w/2	5	36
RAK220.1830.15.IK	180	300	15	15,7	19,0	13,9	f ₂ +w/2	5	36

Weitere Abmessungen auf Anfrage
Further sizes upon request

Abmessungen in mm
Dimensions in mm

Bestellhinweis:

Befestigungsschrauben der Kassetten gehören zum Lieferumfang des Grundhalters.

Ordering note:

The fastening screw is combined with the basic toolholder - no separate order required.

Das Anzugsdrehmoment der Schrauben finden Sie in den Technischen Hinweisen.

For torque specification of the screw, please see Technical Instructions.

Ersatzteile

Spare Parts

Kassette Cassette	Spannschraube Clamping Screw	TORX PLUS®-Schlüssel TORX PLUS® Wrench
RAK220...	6.23T25P	T25PQ

Axialeinstechen

Face Grooving



Kassette

Cassette

RAK220

mit innerer Kühlmittelzufuhr
with through coolant supply

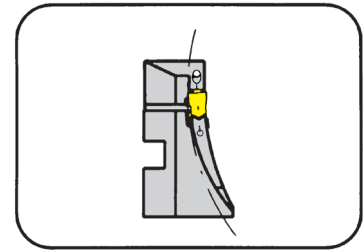

Nutaußen-Ø
Stechtiefe bis
Stechbreite

Outer groove Ø
Depth of groove up to
Width of groove

60-300 mm
15 mm
6 mm

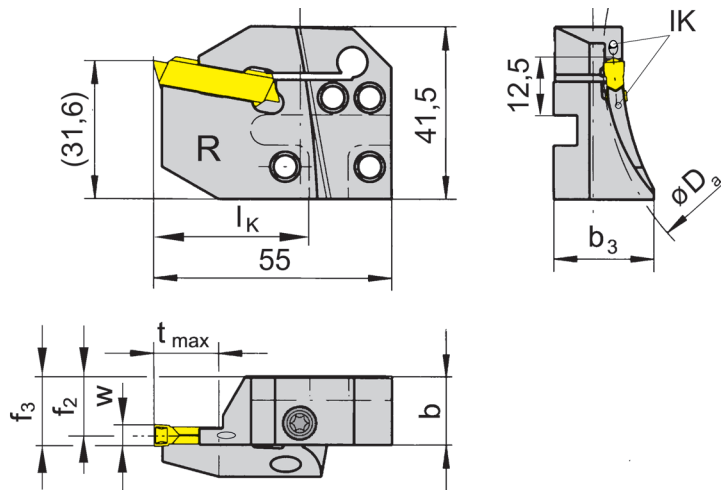

für Wendeschneidplatte
for Indexable insert

Typ 229
Type S229

R = Rechtsausführung
R = right hand version

Bestellnummer Part number	D _{a min}	D _{a max}	t _{max}	b	b ₃	f ₂	f ₃	w	l _k
RAK220.6075.16.IK	60	75	10	15,7	23,0	13,4	f ₂ +w/2	6	36
RAK220.7595.16.IK	75	95	15	15,7	23,0	13,4	f ₂ +w/2	6	36
RAK220.9513.16.IK	95	130	15	15,7	23,0	13,4	f ₂ +w/2	6	36
RAK220.1318.16.IK	130	180	15	15,7	21,2	13,4	f ₂ +w/2	6	36
RAK220.1830.16.IK	180	300	15	15,7	19,0	13,4	f ₂ +w/2	6	36

Weitere Abmessungen auf Anfrage
Further sizes upon request

Abmessungen in mm
Dimensions in mm

Bestellhinweis:

Befestigungsschrauben der Kassetten gehören zum Lieferumfang des Grundhalters.

Ordering note:

The fastening screw is combined with the basic toolholder - no separate order required.

Das Anzugsdrehmoment der Schrauben finden Sie in den Technischen Hinweisen.

For torque specification of the screw, please see Technical Instructions.

Ersatzteile

Spare Parts

Kassette Cassette	Gewindestift Threaded Pin	Spannschraube Clamping Screw	TORX PLUS®-Schlüssel TORX PLUS® Wrench
RAK220...	3.03.913	6.23T25P	T25PQ

Axialeinstechen

Face Grooving



Kassette

Cassette

LIK220

mit innerer Kühlmittelzufuhr
with through coolant supply

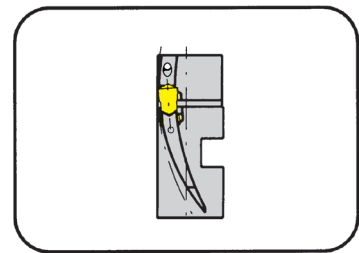

Nutaußen-Ø
Stechtiefe bis
Stechbreite

Outer groove Ø
Depth of groove up to
Width of groove

60-1000 mm
25 mm
4-5 mm

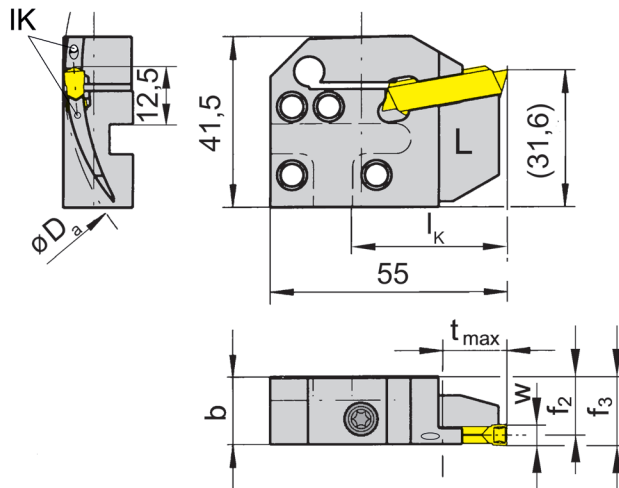

für Wendeschneidplatte
für Indexable insert

Typ 229
Type S229

L = Linksausführung
L = left hand version

Bestellnummer Part number	D _{a min}	D _{a max}	t _{max}	b	f ₂	f ₃	w	l _k
LIK220.6575.04.IK	65	75	10-15	15,7	14,4	f ₂ +w/2	4	36
LIK220.7595.04.IK	75	95	15-25	15,7	14,4	f ₂ +w/2	4	36
LIK220.9513.04.IK	95	130	25	15,7	14,4	f ₂ +w/2	4	36
LIK220.1318.04.IK	130	180	25	15,7	14,4	f ₂ +w/2	4	36
LIK220.1830.04.IK	180	300	25	15,7	14,4	f ₂ +w/2	4	36
LIK220.3000.04.IK	300	1000	25	15,7	14,4	f ₂ +w/2	4	36
LIK220.6075.05.IK	60	75	10-17	15,7	13,9	f ₂ +w/2	5	36
LIK220.7595.05.IK	75	95	17-25	15,7	13,9	f ₂ +w/2	5	36
LIK220.9513.05.IK	95	130	25	15,7	13,9	f ₂ +w/2	5	36
LIK220.1318.05.IK	130	180	25	15,7	13,9	f ₂ +w/2	5	36
LIK220.1830.05.IK	180	300	25	15,7	13,9	f ₂ +w/2	5	36
LIK220.3000.05.IK	300	1000	25	15,7	13,9	f ₂ +w/2	5	36

Weitere Abmessungen auf Anfrage
Further sizes upon request

Abmessungen in mm
Dimensions in mm

Bestellhinweis:

Befestigungsschrauben der Kassetten gehören zum Lieferumfang des Grundhalters.

Ordering note:

The fastening screw is combined with the basic toolholder - no separate order required.

Das Anzugsdrehmoment der Schrauben finden Sie in den Technischen Hinweisen.

For torque specification of the screw, please see Technical Instructions.

Ersatzteile

Spare Parts

Kassette Cassette	Spannschraube Clamping Screw	TORX PLUS®-Schlüssel TORX PLUS® Wrench
LIK220...	6.23T25P	T25PQ

Axialeinstechen

Face Grooving



Kassette

Cassette

LIK220

mit innerer Kühlmittelzufuhr
with through coolant supply

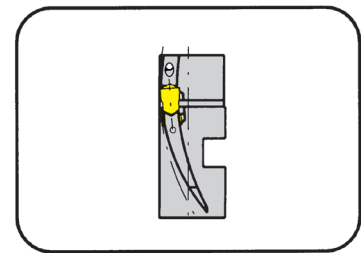

Nutaußen-Ø
Stechtiefe bis
Stechbreite

Outer groove Ø
Depth of groove up to
Width of groove

60-1000 mm
25 mm
6 mm

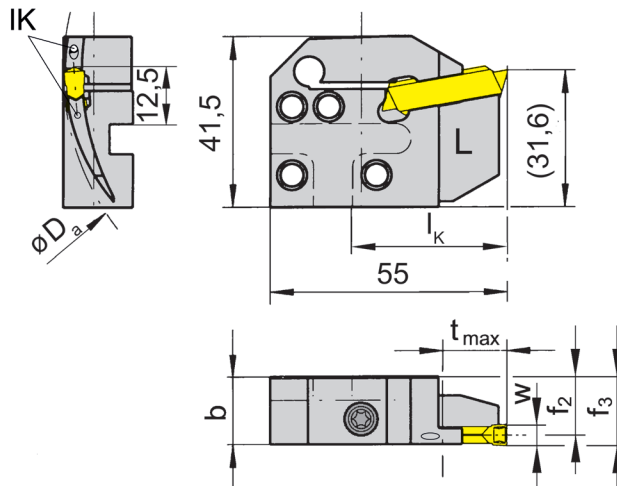

für Wendeschneidplatte
for Indexable insert

Typ 229
Type S229

L = Linksausführung
L = left hand version

Bestellnummer Part number	D _{a min}	D _{a max}	t _{max}	b	f ₂	f ₃	w	l _k
LIK220.6075.06.IK	60	75	10-17	15,7	13,4	f ₂ +w/2	6	36
LIK220.7595.06.IK	75	95	17-25	15,7	13,4	f ₂ +w/2	6	36
LIK220.9513.06.IK	95	130	25	15,7	13,4	f ₂ +w/2	6	36
LIK220.1318.06.IK	130	180	25	15,7	13,4	f ₂ +w/2	6	36
LIK220.1830.06.IK	180	300	25	15,7	13,4	f ₂ +w/2	6	36
LIK220.3000.06.IK	300	1000	25	15,7	13,4	f ₂ +w/2	6	36

Weitere Abmessungen auf Anfrage
Further sizes upon request

Abmessungen in mm
Dimensions in mm

Bestellhinweis:

Befestigungsschrauben der Kassetten gehören zum Lieferumfang des Grundhalters.

Ordering note:

The fastening screw is combined with the basic toolholder - no separate order required.

Das Anzugsdrehmoment der Schrauben finden Sie in den Technischen Hinweisen.

For torque specification of the screw, please see Technical Instructions.

Ersatzteile

Spare Parts

Kassette Cassette	Spannschraube Clamping Screw	TORX PLUS®-Schlüssel TORX PLUS® Wrench
LIK220...	6.23T25P	T25PQ

Axialeinstechen

Face Grooving



Kassette

Cassette

LIK220

mit innerer Kühlmittelzufuhr
with through coolant supply

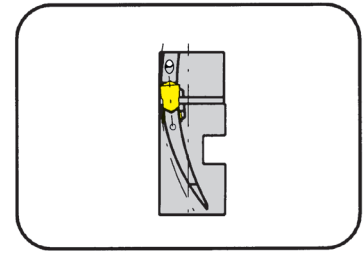

Nutaußen-Ø	Outer groove Ø	60-300 mm
Stechtiefe bis	Depth of groove up to	15 mm
Stechbreite	Width of groove	4-5 mm

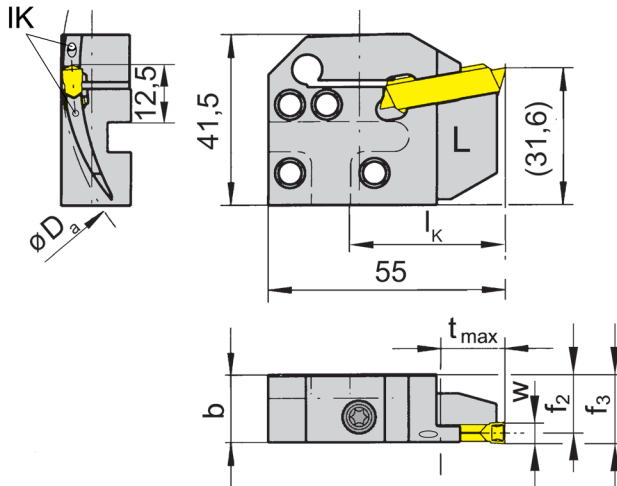

für Wendeschneidplatte
for Indexable insert

Typ 229
Type S229

L = Linksausführung
L = left hand version

Bestellnummer Part number	D _{a min}	D _{a max}	t _{max}	b	f ₂	f ₃	w	l _k
LIK220.6575.14.IK	65	75	10	15,7	14,4	f ₂ +w/2	4	36
LIK220.7595.14.IK	75	95	15	15,7	14,4	f ₂ +w/2	4	36
LIK220.9513.14.IK	95	130	15	15,7	14,4	f ₂ +w/2	4	36
LIK220.1318.14.IK	130	180	15	15,7	14,4	f ₂ +w/2	4	36
LIK220.1830.14.IK	180	300	15	15,7	14,4	f ₂ +w/2	4	36
LIK220.6075.15.IK	60	75	10	15,7	13,9	f ₂ +w/2	5	36
LIK220.7595.15.IK	75	95	15	15,7	13,9	f ₂ +w/2	5	36
LIK220.9513.15.IK	95	130	15	15,7	13,9	f ₂ +w/2	5	36
LIK220.1318.15.IK	130	180	15	15,7	13,9	f ₂ +w/2	5	36
LIK220.1830.15.IK	130	180	15	15,7	13,9	f ₂ +w/2	5	36

Weitere Abmessungen auf Anfrage
Further sizes upon request

Abmessungen in mm
Dimensions in mm

Bestellhinweis:

Befestigungsschrauben der Kassetten gehören zum Lieferumfang des Grundhalters.

Ordering note:

The fastening screw is combined with the basic toolholder - no separate order required.

Das Anzugsdrehmoment der Schrauben finden Sie in den Technischen Hinweisen.

For torque specification of the screw, please see Technical Instructions.

Ersatzteile

Spare Parts

Kassette Cassette	Spannschraube Clamping Screw	TORX PLUS®-Schlüssel TORX PLUS® Wrench
LIK220...	6.23T25P	T25PQ

Axialeinstechen

Face Grooving



Kassette

Cassette

LIK220

mit innerer Kühlmittelzufuhr
with through coolant supply

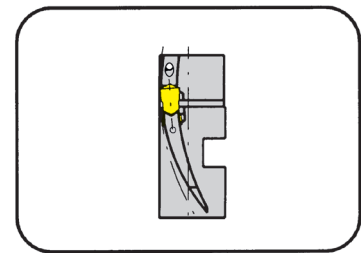

Nutaußen-Ø	Outer groove Ø	60-300 mm
Stechtiefe bis	Depth of groove up to	15 mm
Stechbreite	Width of groove	6 mm

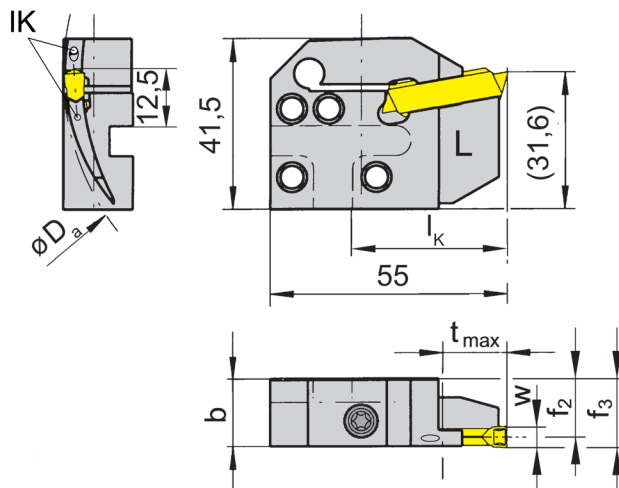

für Wendeschneidplatte
for Indexable insert

Typ 229
Type S229

L = Linksausführung
L = left hand version

Bestellnummer Part number	D _{a min}	D _{a max}	t _{max}	b	f ₂	f ₃	w	l _k
LIK220.6075.16.IK	130	180	10	15,7	13,4	f ₂ +w/2	6	36
LIK220.7595.16.IK	75	95	15	15,7	13,4	f ₂ +w/2	6	36
LIK220.9513.16.IK	95	130	15	15,7	13,4	f ₂ +w/2	6	36
LIK220.1318.16.IK	130	180	15	15,7	13,4	f ₂ +w/2	6	36
LIK220.1830.16.IK	180	300	15	15,7	13,4	f ₂ +w/2	6	36

Weitere Abmessungen auf Anfrage
Further sizes upon request

Abmessungen in mm
Dimensions in mm

Bestellhinweis:

Befestigungsschrauben der Kassetten gehören zum Lieferumfang des Grundhalters.

Ordering note:

The fastening screw is combined with the basic toolholder - no separate order required.

Das Anzugsdrehmoment der Schrauben finden Sie in den Technischen Hinweisen.

For torque specification of the screw, please see Technical Instructions.

Ersatzteile

Spare Parts

Kassette Cassette	Spannschraube Clamping Screw	TORX PLUS®-Schlüssel TORX PLUS® Wrench
LIK220...	6.23T25P	T25PQ

Axialeinstechen

Face Grooving



Kassette

Cassette

RIK220

mit innerer Kühlmittelzufuhr
with through coolant supply

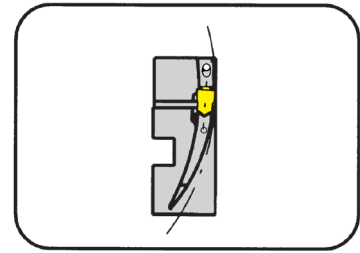

Nutaußen-Ø
Stechtiefe bis
Stechbreite

Outer groove Ø
Depth of groove up to
Width of groove

60-1000 mm
25 mm
4-5 mm

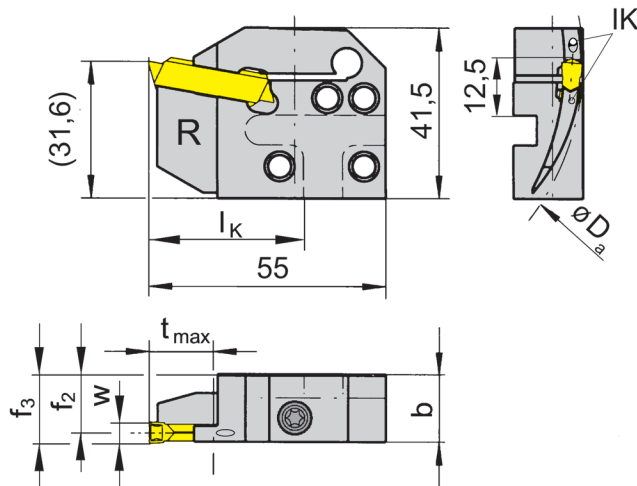

R = Rechtsausführung
R = right hand version

für Wendeschneidplatte
for Indexable insert

Typ 229
Type S229

Bestellnummer Part number	D _{a min}	D _{a max}	t _{max}	b	f ₂	f ₃	w	l _k
RIK220.6575.04.IK	65	75	10-15	15,7	14,4	f ₂ +w/2	4	36
RIK220.7595.04.IK	75	95	15-25	15,7	14,4	f ₂ +w/2	4	36
RIK220.9513.04.IK	95	130	25	15,7	14,4	f ₂ +w/2	4	36
RIK220.1318.04.IK	130	180	25	15,7	14,4	f ₂ +w/2	4	36
RIK220.1830.04.IK	180	300	25	15,7	14,4	f ₂ +w/2	4	36
RIK220.3000.04.IK	300	1000	25	15,7	14,4	f ₂ +w/2	4	36
RIK220.6075.05.IK	60	75	10-17	15,7	13,9	f ₂ +w/2	5	36
RIK220.7595.05.IK	75	95	17-25	15,7	13,9	f ₂ +w/2	5	36
RIK220.9513.05.IK	95	130	25	15,7	13,9	f ₂ +w/2	5	36
RIK220.1318.05.IK	130	180	25	15,7	13,9	f ₂ +w/2	5	36
RIK220.1830.05.IK	180	300	25	15,7	13,9	f ₂ +w/2	5	36
RIK220.3000.05.IK	300	1000	25	15,7	13,9	f ₂ +w/2	5	36

Weitere Abmessungen auf Anfrage
Further sizes upon request

Abmessungen in mm
Dimensions in mm

Bestellhinweis:

Befestigungsschrauben der Kassetten gehören zum Lieferumfang des Grundhalters.

Ordering note:

The fastening screw is combined with the basic toolholder - no separate order required.

Das Anzugsdrehmoment der Schrauben finden Sie in den Technischen Hinweisen.

For torque specification of the screw, please see Technical Instructions.

Ersatzteile

Spare Parts

Kassette Cassette	Spannschraube Clamping Screw	TORX PLUS®-Schlüssel TORX PLUS® Wrench
RIK220...	6.23T25P	T25PQ

Axialeinstechen

Face Grooving



Kassette

Cassette

RIK220

mit innerer Kühlmittelzufuhr
with through coolant supply

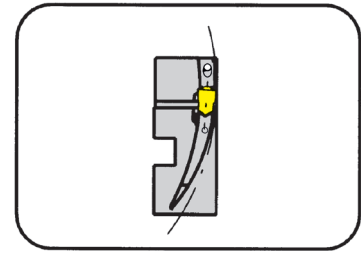

Nutaußen-Ø	Outer groove Ø	60-1000 mm
Stechtiefe	Depth of groove	25 mm
Stechbreite	Width of groove	6 mm

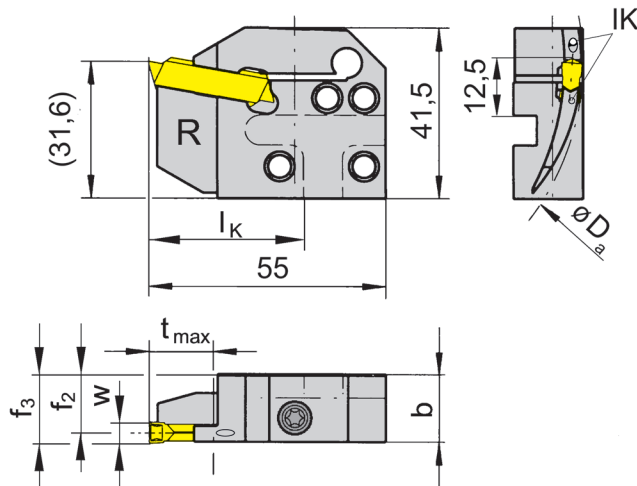

für Wendeschneidplatte
for Indexable insert

Typ 229
Type S229

R = Rechtsausführung
R = right hand version

Bestellnummer Part number	D _{a min}	D _{a max}	t _{max}	b	f ₂	f ₃	w	I _k
RIK220.6075.06.IK	60	75	10-17	15,7	13,4	f ₂ +w/2	6	36
RIK220.7595.06.IK	75	95	17-24	15,7	13,4	f ₂ +w/2	6	36
RIK220.9513.06.IK	95	130	25	15,7	13,4	f ₂ +w/2	6	36
RIK220.1318.06.IK	130	180	25	15,7	13,4	f ₂ +w/2	6	36
RIK220.1830.06.IK	180	300	25	15,7	13,4	f ₂ +w/2	6	36
RIK220.3000.06.IK	300	1000	25	15,7	13,4	f ₂ +w/2	6	36

Weitere Abmessungen auf Anfrage
Further sizes upon request

Abmessungen in mm
Dimensions in mm

Bestellhinweis:

Befestigungsschrauben der Kassetten gehören zum Lieferumfang des Grundhalters.

Ordering note:

The fastening screw is combined with the basic toolholder - no separate order required.

Das Anzugsdrehmoment der Schrauben finden Sie in den Technischen Hinweisen.

For torque specification of the screw, please see Technical Instructions.

Ersatzteile

Spare Parts

Kassette Cassette	Spannschraube Clamping Screw	TORX PLUS®-Schlüssel TORX PLUS® Wrench
RIK220...	6.23T25P	T25PQ

Axialeinstechen

Face Grooving



Kassette

Cassette

RIK220

mit innerer Kühlmittelzufuhr
with through coolant supply

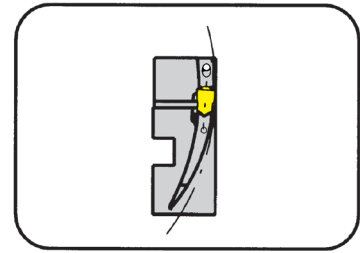

Nutaußen-Ø
Stechtiefe bis
Stechbreite

Outer groove Ø
Depth of groove up to
Width of groove

60-300 mm
15 mm
4-5 mm

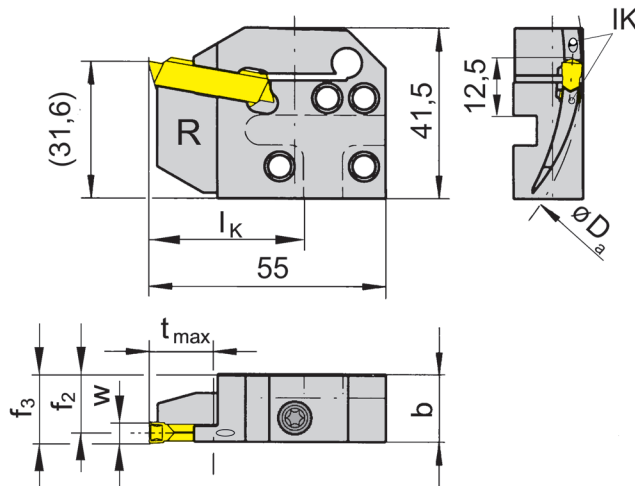

R = Rechtsausführung
R = right hand version

für Wendeschneidplatte
for Indexable insert

Typ 229
Type S229

Bestellnummer Part number	D _{a min}	D _{a max}	t _{max}	b	f ₂	f ₃	w	I _k
RIK220.6575.14.IK	65	75	10	15,7	14,4	f ₂ +w/2	4	36
RIK220.7595.14.IK	75	95	15	15,7	14,4	f ₂ +w/2	4	36
RIK220.9513.14.IK	95	130	15	15,7	14,4	f ₂ +w/2	4	36
RIK220.1318.14.IK	130	180	15	15,7	14,4	f ₂ +w/2	4	36
RIK220.1830.14.IK	180	300	15	15,7	14,4	f ₂ +w/2	4	36
RIK220.6075.15.IK	60	75	10	15,7	13,9	f ₂ +w/2	5	36
RIK220.7595.15.IK	75	95	15	15,7	13,9	f ₂ +w/2	5	36
RIK220.9513.15.IK	95	130	15	15,7	13,9	f ₂ +w/2	5	36
RIK220.1318.15.IK	130	180	15	15,7	13,9	f ₂ +w/2	5	36
RIK220.1830.15.IK	130	180	15	15,7	13,9	f ₂ +w/2	5	36

Weitere Abmessungen auf Anfrage
Further sizes upon request

Abmessungen in mm
Dimensions in mm

Bestellhinweis:

Befestigungsschrauben der Kassetten gehören zum Lieferumfang des Grundhalters.

Ordering note:

The fastening screw is combined with the basic toolholder - no separate order required.

Das Anzugsdrehmoment der Schrauben finden Sie in den Technischen Hinweisen.

For torque specification of the screw, please see Technical Instructions.

Ersatzteile

Spare Parts

Kassette Cassette	Spannschraube Clamping Screw	TORX PLUS®-Schlüssel TORX PLUS® Wrench
RIK220...	6.23T25P	T25PQ

Axialeinstechen

Face Grooving



Kassette

Cassette

RIK220

mit innerer Kühlmittelzufuhr
with through coolant supply

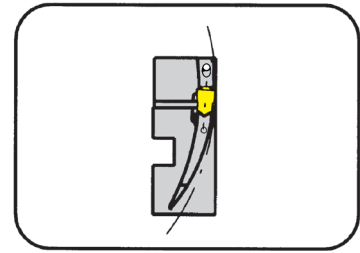

Nutaußen-Ø
Stechtiefe bis
Stechbreite

Outer groove Ø
Depth of groove up to
Width of groove

60-300 mm
15 mm
6 mm

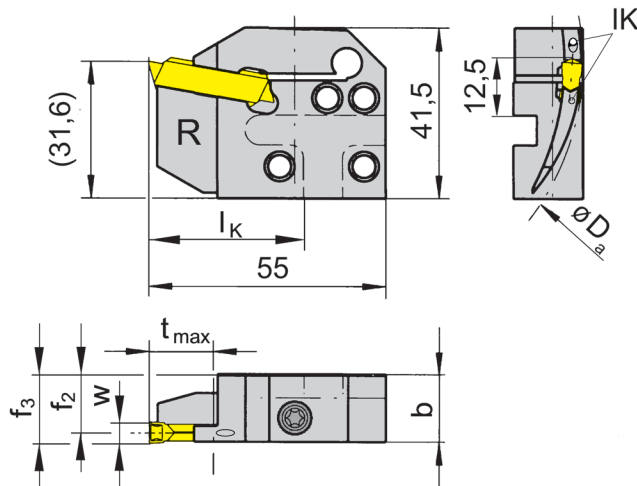

für Wendeschneidplatte
for Indexable insert

Typ 229
Type S229

R = Rechtsausführung
R = right hand version

Bestellnummer Part number	D _{a min}	D _{a max}	t _{max}	b	f ₂	f ₃	w	I _K
RIK220.6075.16.IK	60	75	10	15,7	13,4	f ₂ +w/2	6	36
RIK220.7595.16.IK	75	95	15	15,7	13,4	f ₂ +w/2	6	36
RIK220.9513.16.IK	95	130	15	15,7	13,4	f ₂ +w/2	6	36
RIK220.1318.16.IK	130	180	15	15,7	13,4	f ₂ +w/2	6	36
RIK220.1830.16.IK	180	300	15	15,7	13,4	f ₂ +w/2	6	36

Weitere Abmessungen auf Anfrage
Further sizes upon request

Abmessungen in mm
Dimensions in mm

Bestellhinweis:

Befestigungsschrauben der Kassetten gehören zum Lieferumfang des Grundhalters.

Ordering note:

The fastening screw is combined with the basic toolholder - no separate order required.

Das Anzugsdrehmoment der Schrauben finden Sie in den Technischen Hinweisen.

For torque specification of the screw, please see Technical Instructions.

Ersatzteile

Spare Parts

Kassette Cassette	Spannschraube Clamping Screw	TORX PLUS®-Schlüssel TORX PLUS® Wrench
RIK220...	6.23T25P	T25PQ

Grundkörper Schnittstelle 220

Basic body Interface 220

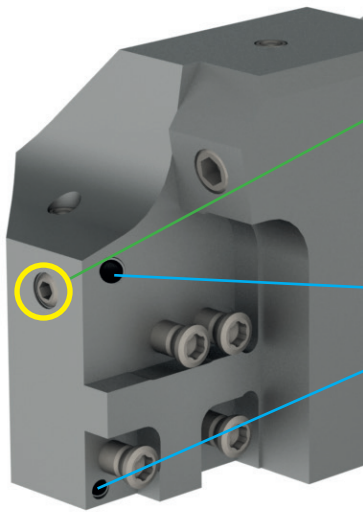

Verschuß der oberen Kühlmittelübergabe
an die Kassette durch Zylinderschraube

Closure of the upper coolant supply
to the cassette by cylinder head screw

Kühlmittelzufuhr

Coolant supply

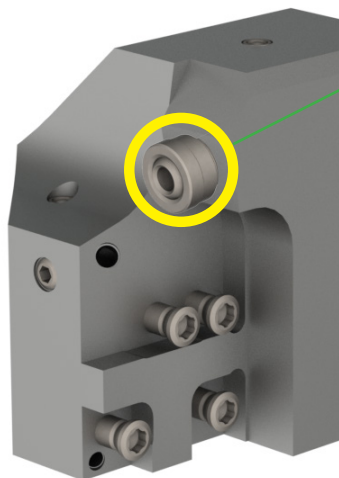

Einsatz von Kassetten ohne innere Kühlmittel-
zufuhr unter Verwendung der Kugelspritzdüse

Verschuß der oberen Kühlmittelübergabe
an die Kassette durch Zylinderschraube

Use of cassettes without internal coolant supply using
the coolant spray nozzle

Closure of the upper coolant supply
to the cassette by cylinder head screw

Nachstehende Drehmomente sind für die Spannschrauben zulässig. Wir empfehlen keine zusätzlichen Gleitmittel wie Kupferpaste oder ähnliches für die Schrauben zu verwenden.

Following torques are allowed for screws of inserts. We recommend to use no additional gliding means (such as copper paste) for screws.

Kapitel A Chapter A	Schraube Screw	M _d Nm	Schlüssel Clamping wrench	Klinge Blade
NK100.3215...	6.23T25P	7,0	T25PQ	DT25PK/DT25PQ
NK220.3218...	6.23T25P	7,0	T25PQ	DT25PK/DT25PQ
NK224.3215...	5.13T20P	6,0	T20PQ	DT20PK/DT20PQ
NK316.0220...	5.12T20P	6,5	T20PQ	DT20PK/DT20PQ
NK356	5.12T20P	6,0	T20PQ	DT20PK/DT20PQ
NK360.0220...	5.32.3T15P	5,0	T15PQ	DT15PK
LAK220	6.23T25P	7,0	T25PQ	DT25PK/DT25PQ
LAK224	5.13T20P	6,0	T20PQ	DT20PK/DT20PQ
LIK220	6.23T25P	7,0	T25PQ	DT25PK/DT25PQ
LIK224	5.13T20P	6,0	T20PQ	DT20PK/DT20PQ
RAK220	6.23T25P	7,0	T25PQ	DT25PK/DT25PQ
RAK224	5.13T20P	6,0	T20PQ	DT20PK/DT20PQ
RIK220	6.23T25P	7,0	T25PQ	DT25PK/DT25PQ
NK34T...00	030.4093T15P	1,5	T15PQ	DT15PK
NK34T...10	030.4093T15P	3,0	T15PQ	DT15PK
NK34T...20	030.4010T15P	5,0	T15PQ	DT15PK
NK34T...30	030.5012T15P	6,0	T15PQ	DT15PK
NK34T...40	030.5012T15P	6,0	T15PQ	DT15PK
NK64T...10	030.4010T15P	4,0	T15PQ	DT15PK
NK64T...20	030.4010T15P	5,0	T15PQ	DT15PK
NK274	030.3509T15P	3,0	T15PQ	DT15PK
AK25A...02	5.13T20P	2,5	T20PQ	DT20PK
AK25A...03	5.13T20P	3,0	T20PQ	DT20PK
AK25A...04	5.13T20P	3,5	T20PQ	DT20PK
NK220.3215	6.23T25P	7,0	T25PQ	DT25PK
NK368...01	010.0004.0586	4,0	T10PL	DT10PK
NK368...02	010.0004.0620	4,0	T10PL	DT10PK

Axialeinstechen Face Grooving

Wahl der Kassette

Verwenden Sie immer die Kassette, welche vom Bereich für den Außendurchmesser Ihrer Anwendung passt, um die größtmögliche Stabilität des Werkzeugs zu erhalten.

Cassette Selection

Select the cassette to suit the major diameter of the face groove to be cut.

Vemeiden von Vibrationen

Die Auskraglänge (x) des Klemmhalters sollte so gering wie möglich sein, um Vibrationen und Ablenkungen zu vermeiden.

Stable Setup

The tool should be set to give the minimum overhang to achieve maximum stability.

Arbeitsfolge

Das Auskammern breiterer Planeinstiche sollte stets vom Außendurchmesser nach innen erfolgen. Liegt der Ø-Bereich der Kassette am inneren Ø, kann nur von innen nach außen gefahren werden.

Working Practice

When turning to open up the face groove the cut should be taken from the major Ø towards the minor Ø.

Einrichten des Werkzeugs

Richten Sie das Werkzeug exakt auf Drehmitte aus, um ein Anlaufen bzw. Streifen der Kommaunterstützung zu vermeiden.

Tool Setup

The tool should be set to centre height to ensure correct cutting and support clearance.

Achten Sie auf parallele Stellung des Werkzeugs zur Drehachse.

The tool must be set parallel to the rotation axis of the workpiece.

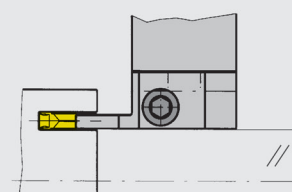
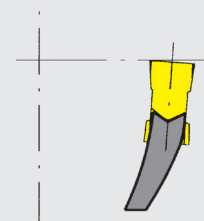
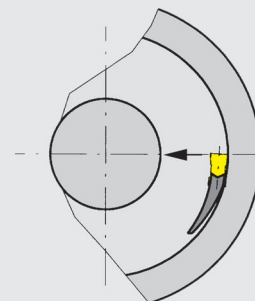
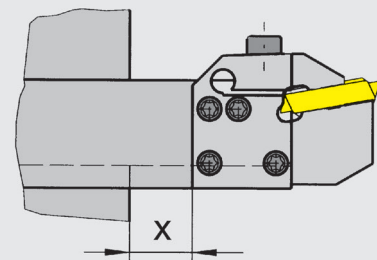

Die passenden Schneidplatten und weitere Informationen finden Sie in unserem Katalog „STECHDREHEN“.

You will find the right inserts and further information in our catalogue „GROOVING“.

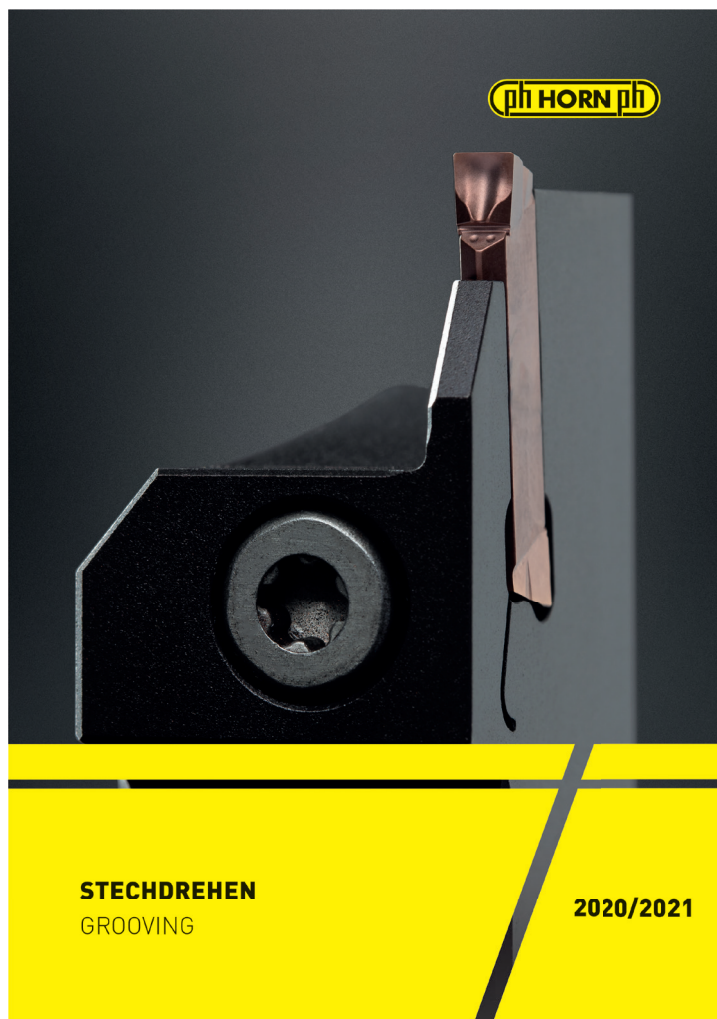





**FINDEN SIE JETZT IHRE
PASSENDE WERKZEUGLÖSUNG.**

FIND YOUR RIGHT
TOOLING SOLUTION NOW.

www.phorn.de

DEUTSCHLAND, STAMMSITZ

GERMANY, HEADQUARTERS

—

Hartmetall Werkzeugfabrik

Paul Horn GmbH

Horn-Straße 1

D-72072 Tübingen

Tel +49 7071 / 70040

Fax +49 7071 / 72893

info@phorn.de

www.phorn.de

Find your country:

www.phorn.com/countries