

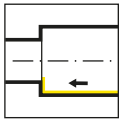

108迷你系列新型断屑槽
镗削时更好控制铁屑

**NEW CHIPBREAKING GEOMETRY
FOR 108 MINI SYSTEM**

GOOD CHIP CONTROL WHEN BORING



镗内孔
Internal boring

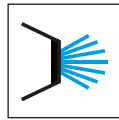

内冷
Internal coolant



槽型 .I
Geometry .I

Alle Abmessungen sind in mm angegeben, sofern nicht anders vermerkt.

All dimensions are in mm, unless otherwise stated.

Unsere Lieferzeiten: Einsatz für Werkstoffgruppen:

▲ ab Lager ● empfohlen

△ 4 Wochen ○ bedingt einsetzbar

- nicht geeignet

Delivery times: Use for material groups:

▲ on stock ● recommended

△ 4 weeks ○ alternative recommendation

- not suitable

HORN连接接口代码-它需要做什么?

连接接口代码确保您始终能够找到适当的刀具，并显示在刀柄和刀片上。如果编码匹配，则可以在相应的刀柄中使用刀片。这也适用于我们的模块化刀柄系统，其中连接代码表示刀柄和刀夹之间的接口。

The HORN connection interface code - what is it needed for?

The connection interface code ensures that you will always find the appropriate tools and is shown on toolholders and inserts. If the codes match, the insert can be used in the corresponding toolholder. This also applies to our modular holder system, where the connection code indicates the interface between the holder and the cassette.

HORN连接接口代码及可能的组合:

HORN connection interface codes and possible combinations:

HIS = 刀片座 / Insert seat

HWS = 工件侧接口 / Interface workpiece side

HIS	↔	HWS
HMS	↔	HWS

HMS = 机床侧接口 / Interface machine side

刀片范例

Example insert

产品型号 Part number	s	f	a	r	d	D _{min}	HIS	EG35	EG55	IG35
RS108.0820.105	3,37	4,65	7,65	0,05	6	7,8	306060R		▲	▲

刀杆示例

Example toolholder

产品型号 Part number	d	l ₁	l ₂	h	l ₄	d ₁	HWS
B108.0008.00	8	60	12,5	7	35	6	306060R • 306060L

不同之处 更多可能

THE DIFFERENCE: MORE POSSIBILITIES

- **L-槽型适用于内仿型，轴，面车削**
I-geometry for internal copy, longitudinal and face turning
- **对钢、不锈钢及有色无铅金属有良好的切屑控制**
Good chip control in steel, stainless steel and non-ferrous lead-free metals
- **刀尖角R0.05-0.20mm**
Corner radii 0.05 to 0.20 mm

槽型和进给

Geometries and Feed Rates



槽型

Geometry

材质

Material

进给 f [mm/U]

Feed rate f [mm/rev]

加工类型

Machining

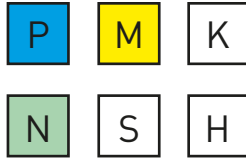
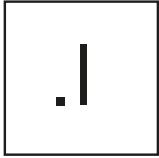

← 0,05-0,15

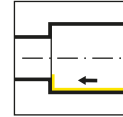

切削速度 v_c [m/min]

Cutting speed v_c [m/min]

70 - 130

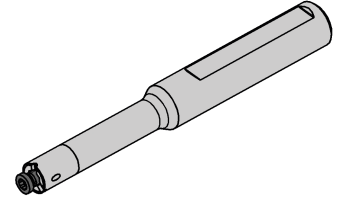
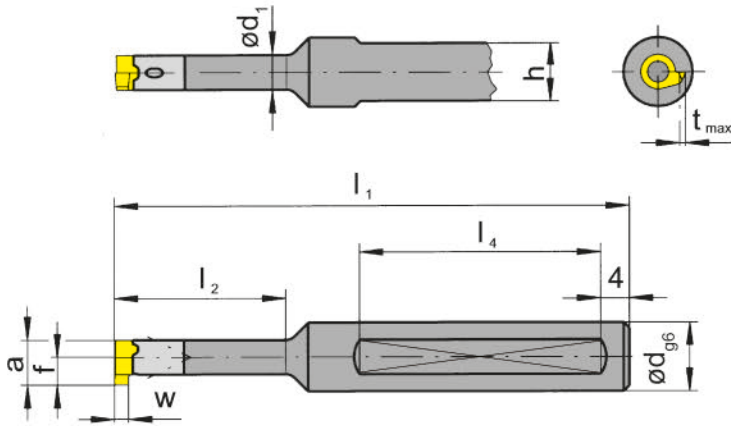
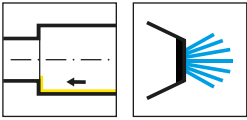

产品型号 Part number	d	l_1	l_2	h	l_4	d_1	HWS
B108.0006.01A	6	65	-	-	-	-	306060R • 306060L
B108.0008.00	8	60	12,5	7	35	6	306060R • 306060L
B108.0008.01	8	70	21	7	40	6	306060R • 306060L
B108.0012.00	12	70	12,5	11	40	6	306060R • 306060L
B108.0012.01	12	80	21	11	45	6	306060R • 306060L
B108.0012.02	12	90	30	11	45	6	306060R • 306060L
B108.0012.03	12	100	42	11	45	6	306060R • 306060L

备件

Spare Parts

刀杆 Toolholder	锁紧螺钉 Clamping Screw	TORX PLUS®-扳手 TORX PLUS® Wrench
B108...	2.6.5T8EP	T8PL

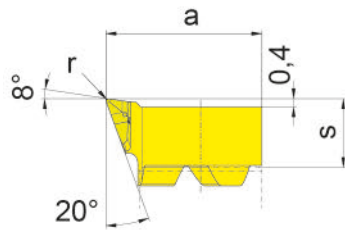
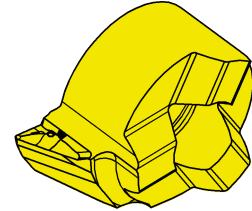
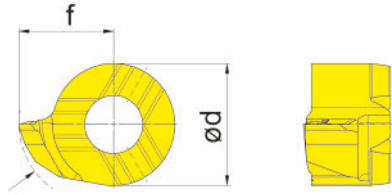
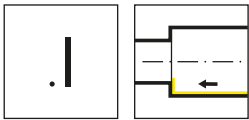

R = 右手刀
R = right hand version shown

▲ 库存
on stock

硬质合金牌号
Carbide grades
▲ 4 周
4 weeks

Bestellnummer Part number	s	f	a	r	d	D _{min}	HIS	EG35	EG55	IG35
RS108.0820.105	3,37	4,65	7,65	0,05	6	7,8	306060R	Δ		Δ
RS108.0820.110	3,38	4,65	7,65	0,1	6	7,8	306060R	▲		▲
RS108.0820.120	3,4	4,65	7,65	0,2	6	7,8	306060R		▲	▲
P	●	●	-							
M	●	○	●							
K	-	-	-							
N	○	○	○							
S	-	-	-							
H	-	-	-							





找到适合你的刀具解决方案

FIND YOUR RIGHT
TOOLING SOLUTION NOW.

horn-group.com

DEUTSCHLAND, STAMMSITZ

GERMANY, HEADQUARTERS

—

Hartmetall Werkzeugfabrik
Paul Horn GmbH
Horn-Straße 1
D-72072 Tübingen

Tel +49 7071 / 70040

Fax +49 7071 / 72893

info@de.horn-group.com

horn-group.com

CHINA

—

HORN (Shanghai) Trading Co. Ltd.
Room 905, No. 518 Anyuan Road,
P.R. of China Putuo District,
Shanghai 200060 上海市安远路518
号905室 邮编: 200060

Tel +86 21 52833505 ; 52833205

Fax +86 21 52832562

info@phorn.cn

www.phorn.cn