



**406&409新型几何型体**

铣槽，铣断，仿型铣

**NEW CUTTING GEOMETRY FOR  
MILLING SYSTEMS 406 AND 409**

FOR GROOVING, PARTING-OFF AND  
FORM GROOVING INSERTS

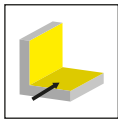

圆角铣削  
Corner broaching

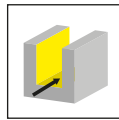

槽铣  
Groove milling

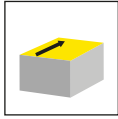

面铣  
Face milling

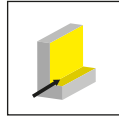

方肩铣  
Trimming

无特殊说明外，所有尺寸单位为mm.

All dimensions are in mm, unless otherwise stated.

### 交期

- ▲ 有库存
- △ 4周

### 适用切削材质

- 推荐
- 可选
- 不适合

### Delivery times:

- ▲ on stock
- △ 4 weeks

### Use for material groups:

- recommended
- alternative recommendation
- not suitable

### HORN连接接口代码-它需要做什么?

连接接口代码确保您始终能够找到适当的刀具，并显示在刀柄和刀片上。如果编码匹配，则可以在相应的刀柄中使用刀片。这也适用于我们的模块化刀柄系统，其中连接代码表示刀柄和刀夹之间的接口。

### The HORN connection interface code - what is it needed for?

The connection interface code ensures that you will always find the appropriate tools and is shown on toolholders and inserts. If the codes match, the insert can be used in the corresponding toolholder. This also applies to our modular holder system, where the connection code indicates the interface between the holder and the cassette.

### HORN连接接口代码及可能的组合:

HORN connection interface codes and possible combinations:

**HIS** = 刀片座 / Insert seat

**HWS** = 工件侧接口 / Interface workpiece side

HIS	↔	HWS
HMS	↔	HWS

**HMS** = 机床侧接口 / Interface machine side

### 刀片范例

Example insert

产品型号 Part number	$a_p$	h	$r_x$	HIS	K10	AS46	AS4B	IG35	NE2B
<b>R406.063.U.02</b>	6,3	3,85	0,2	40600R		△	▲		

### 刀杆实例

Example toolholder

产品型号 Part number	Z	Ds	d	$l_1$	$l_2$	$d_1$	$l_3$	$a_p$	Form	$n_{max}$	HWS
<b>M406.016.D16.3.02A</b>	2	16	16	75	25	15	48	6,3	A	23700	40600R

# 不同之处 更多可能

THE DIFFERENCE:  
MORE POSSIBILITIES

- **优化了刀片几何型体**  
Optimised insert geometry
- **抛光断屑槽**  
Polished chipbreaker
- **加工N类材料特殊牌号**  
Special grade for cutting group N

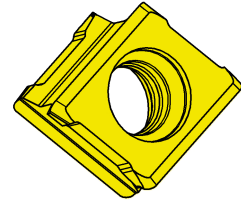
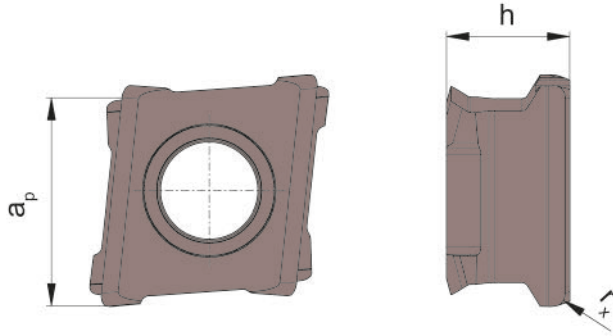
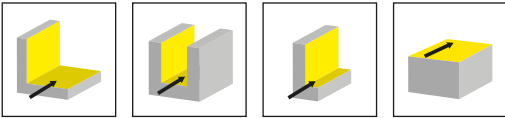

硬质合金牌号  
Carbide grades

▲ 库存  
on stock

△ 4 无库存  
4 weeks

产品型号 Part number	$a_p$	$h$	$r_x$	HIS	K10	AS46	AS4B	IG35	NE2B
R406.063.U.02	6,3	3,85	0,2	40600R		△	▲		
R406.063.U.04	6,3	3,85	0,4	40600R		▲	▲		
R406.063.U.08	6,3	3,85	0,8	40600R		▲	▲		
R406.063.W.02	6,3	3,85	0,2	40600R	▲			▲	▲
R406.063.W.04	6,3	3,85	0,4	40600R	▲			▲	▲
R406.063.W.08	6,3	3,85	0,8	40600R	▲			▲	▲
L406.063.U.02	6,3	3,85	0,2	40600L		△	▲		
L406.063.U.04	6,3	3,85	0,4	40600L		▲	▲		
L406.063.U.08	6,3	3,85	0,8	40600L		▲	▲		
L406.063.W.02	6,3	3,85	0,2	40600L	▲			▲	▲
L406.063.W.04	6,3	3,85	0,4	40600L	▲			▲	▲
L406.063.W.08	6,3	3,85	0,8	40600L	▲			▲	▲
P	-	○	●	-	-				
M	-	○	●	-	-				
K	-	●	●	-	-				
N	●	○	○	-	●				
S	-	○	●	-	-				
H	-	-	-	-	-				

4有效切削刃  
with 4 usable cutting edges

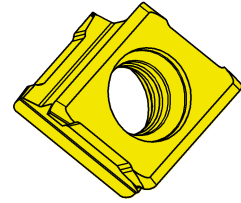
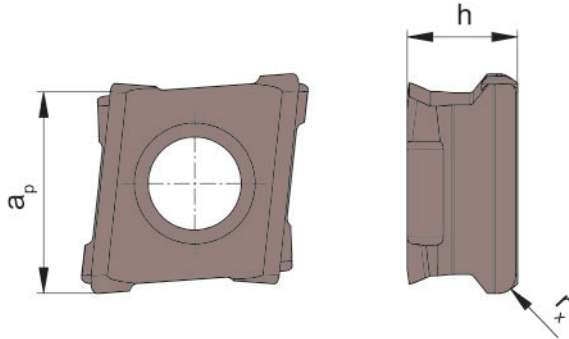
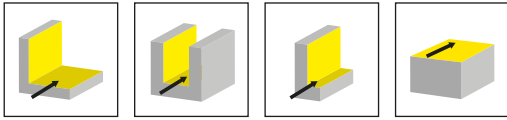

硬质合金牌号  
Carbide grades

▲ 库存  
on stock

△ 4 周  
4 weeks

产品型号 Part number	$a_p$	$h$	$r_x$	HIS	K10	AS46	AS4B	IG35	NE2B
R409.093.U.02	9,3	5,2	0,2	40900R		△	▲		
R409.093.U.04	9,3	5,2	0,4	40900R		▲	▲		
R409.093.U.08	9,3	5,2	0,8	40900R		▲	▲		
R409.093.U.12	9,3	5,2	1,2	40900R		▲	▲		
R409.093.W.02	9,3	5,2	0,2	40900R	▲			▲	▲
R409.093.W.04	9,3	5,2	0,4	40900R	▲			▲	▲
R409.093.W.08	9,3	5,2	0,8	40900R	▲			▲	▲
R409.093.W.12	9,3	5,2	1,2	40900R				▲	▲
L409.093.U.02	9,3	5,2	0,2	40900L		△	▲		
L409.093.U.04	9,3	5,2	0,4	40900L		▲	▲		
L409.093.U.08	9,3	5,2	0,8	40900L		▲	▲		
L409.093.U.12	9,3	5,2	1,2	40900L		△	▲		
L409.093.W.02	9,3	5,2	0,2	40900L	▲			▲	▲
L409.093.W.04	9,3	5,2	0,4	40900L	▲			▲	▲
L409.093.W.08	9,3	5,2	0,8	40900L	▲			▲	▲
L409.093.W.12	9,3	5,2	1,2	40900L				▲	△
P	-	○	●	-	-				
M	-	○	●	-	-				
K	-	●	●	-	-				
N	●	○	○	-	●				
S	-	○	●	-	-				
H	-	-	-	-	-				

4有效切削刃  
with 4 usable cutting edges

更多信息请见我们铣削系统样本 M部分

Further information can be found in our catalogue MILLING SYSTEMS, chapter M.

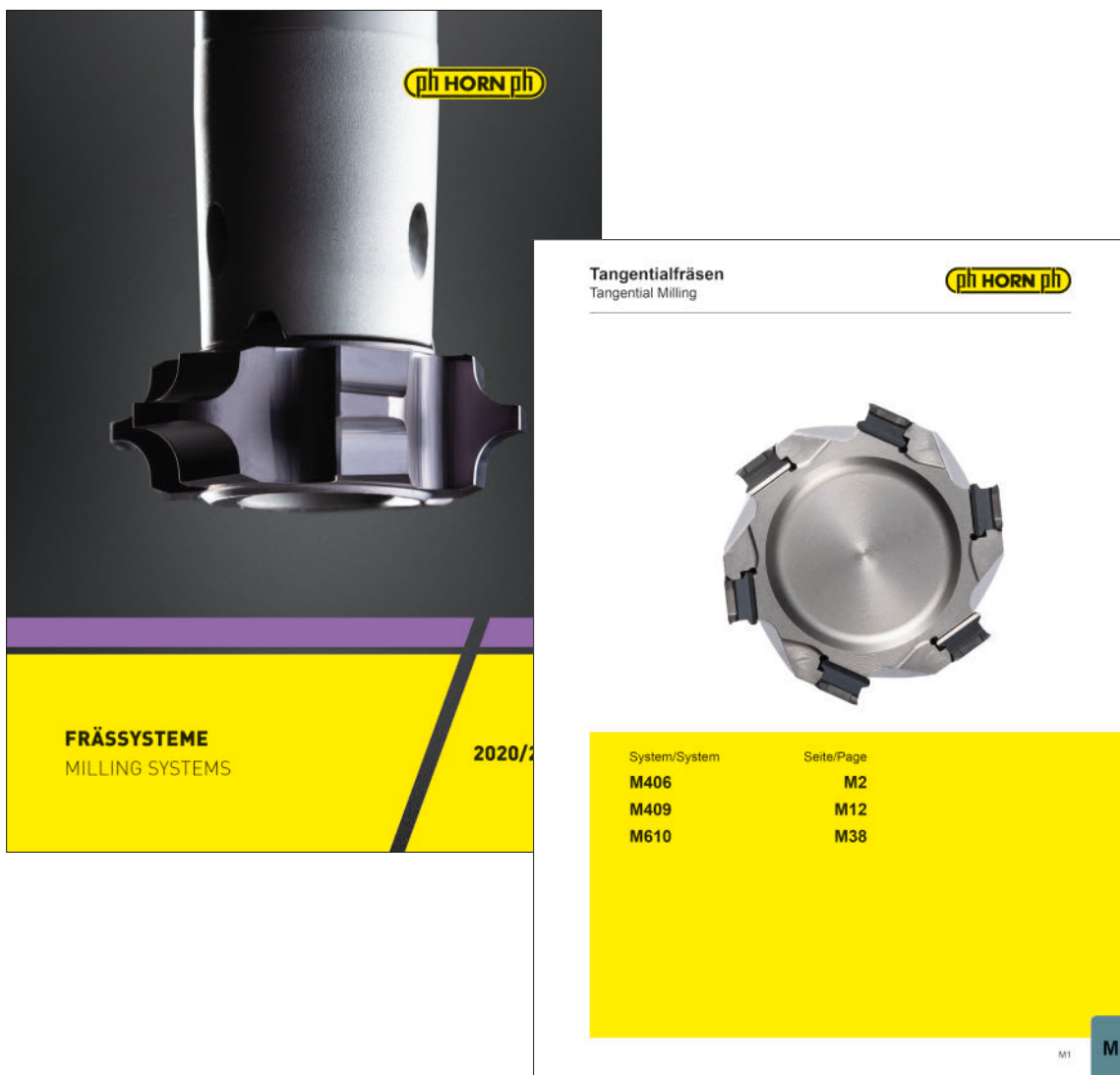

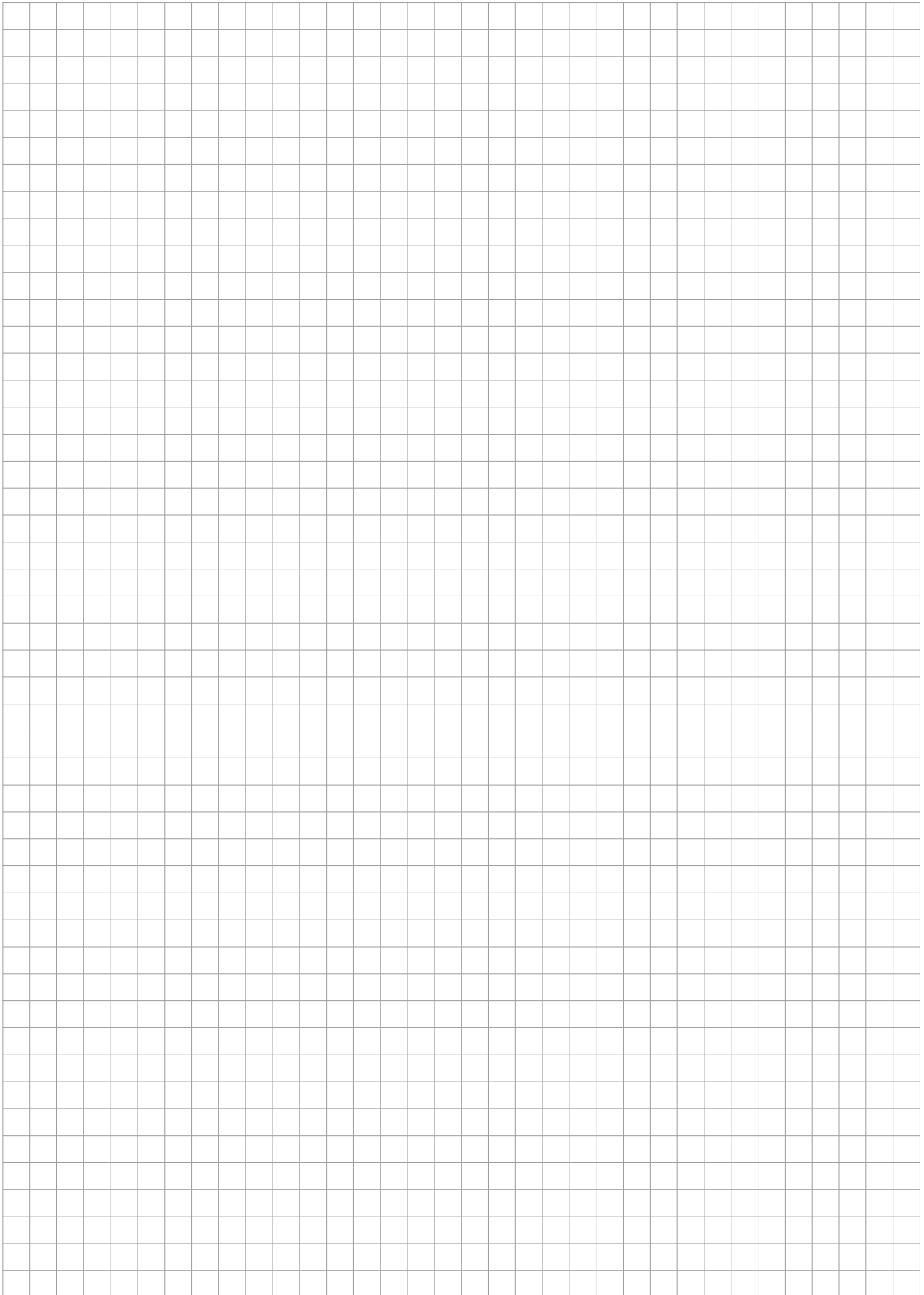



**FINDEN SIE JETZT IHRE  
PASSENDE WERKZEUGLÖSUNG.**

FIND YOUR RIGHT  
TOOLING SOLUTION NOW.

[horn-group.com](http://horn-group.com)

**DEUTSCHLAND, STAMMSITZ**

GERMANY, HEADQUARTERS

—

Hartmetall Werkzeugfabrik  
Paul Horn GmbH  
Horn-Straße 1  
D-72072 Tübingen

Tel +49 7071 / 70040

Fax +49 7071 / 72893

[info@de.horn-group.com](mailto:info@de.horn-group.com)

[horn-group.com](http://horn-group.com)

**CHINA**

—

HORN (Shanghai) Trading Co. Ltd.  
Room 905, No. 518 Anyuan Road,  
P.R. of China Putuo District,  
Shanghai 200060 上海市安远路518  
号905室 邮编: 200060

Tel +86 21 52833505 ; 52833205

Fax +86 21 52832562

[info@phorn.cn](mailto:info@phorn.cn)

[www.phorn.cn](http://www.phorn.cn)