

ph HORN ph



NEW

## 螺纹铣削系统 304

用于直径9毫米以上的小螺纹

THREAD MILLING SYSTEM 304

for small threads from 9 mm diameter





# 不同之处： 更多可能

## THE DIFFERENCE: MORE POSSIBILITIES

- **由于可更换的刀片从而节省成本**  
Cost saving due to exchangeable insert
- **可提供各种尺寸的库存**  
Different sizes available from stock
- **全牙和半牙的螺纹铣削**  
Thread milling in partial and full profile

# 螺纹铣削 ( 内圆 ) , 非全牙型

## Thread Milling (internal) Partial profile



刀片  
Insert

# 304

螺距  
切削刃Ø

Pitch  
Cutting edge Ø

0.5 mm  
7.7 mm

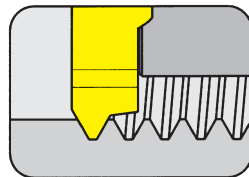

用于铣削刀柄  
for Milling shank

型号 M304  
Type

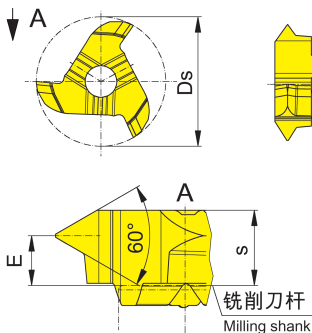

图示=右手型  
Picture = right hand cutting version

ISO米制螺纹  
Metric ISO-thread

产品型号 Part number	P	P <sub>max</sub>	E	s	Ds	AS45
<b>304.0515.01</b>	0.5	1.5	1.9	2.75	7.7	▲
▲ 库存 / on stock	△ 4周 / 4 weeks	x 根据要求 / upon request				P ●
● 推荐 / recommended						M ●
○ 次推荐 / alternative recommendation						K ●
- 不合适 / not suitable						N ○
■ 非涂层 / uncoated grades						S ●
■ 涂层 / coated grades						H -
■ 钎焊/金属陶瓷 / brazed/Cermet						

尺寸单位 : mm  
Dimensions in mm

硬质合金牌号  
Carbide grades



# 螺纹铣削 ( 内圆 ) , 全牙型

## Thread Milling (internal) Full profile



刀片  
Insert

# 304

螺距  
切削刃Ø

Pitch  
Cutting edge Ø

1.5 mm  
7.7 mm

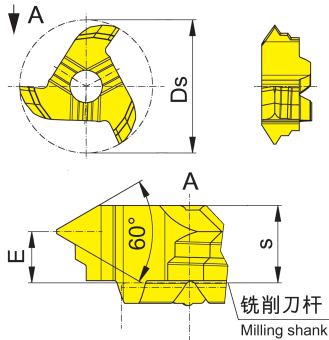
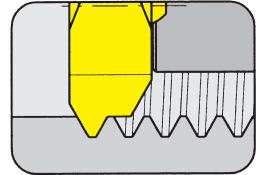

图示=右手型  
Picture = right hand cutting version

用于铣削刀柄  
for Milling shank

型号 M304  
Type

ISO米制螺纹  
Metric ISO-thread

产品型号 Part number	P	E	s	Ds	AS45
<b>304.0815.02</b>	1.5	2	2.75	7.7	▲

- ▲ 库存 / on stock Δ 4周 / 4 weeks x 根据要求 / upon request
- 推荐 / recommended
- 次推荐 / alternative recommendation
- 不合适 / not suitable
- 非涂层 / uncoated grades
- 涂层 / coated grades
- 钎焊/金属陶瓷 / brazed/Cermet

尺寸单位 : mm  
Dimensions in mm

P	●
M	●
K	●
N	○
S	●
H	-

硬质合金牌号  
Carbide grades

# 螺纹铣削 ( 内圆 ) , 全牙型

## Thread Milling (internal) Full profile



刀片  
Insert

# 304

每英寸牙数  
切削刃Ø

Threads per inch  
Cutting edge Ø

19  
7.7 mm

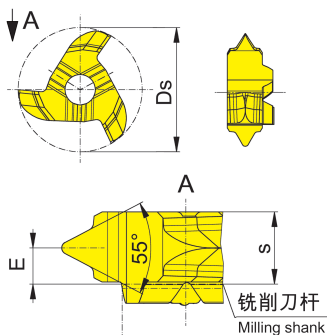
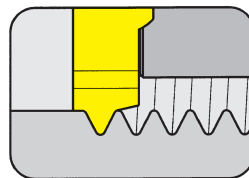

图示=右手型  
Picture = right hand cutting version

用于铣削刀柄  
for Milling shank

型号 M304  
Type

惠氏管螺纹DIN  
ISO228;(259)和2999  
Whitworth pipe thread as per  
DIN ISO 228;(259) and 2999

产品型号 Part number	TPI	E	s	Ds	AS45
<b>304.5519.02</b>	19	1.5	2.75	7.7	▲

▲ 库存 / on stock Δ 4周 / 4 weeks x 根据要求 / upon request

● 推荐 / recommended

○ 次推荐 / alternative recommendation

- 不合适 / not suitable

■ 非涂层 / uncoated grades

■ 涂层 / coated grades

■ 钎焊/金属陶瓷 / brazed/Cermet

尺寸单位 : mm

Dimensions in mm

P	▲
M	●
K	●
N	○
S	●
H	-

硬质合金牌号  
Carbide grades

### 螺纹刀片的选择

Selection for thread inserts

型号 **304**

type

非全牙型，米制 型号 304

Partial profile, metric type 304

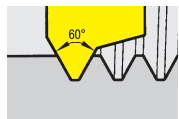

螺距 / Pitch P	0,5	(0,75)	1,0	(1,25)	1,5
公称直径 / Nominal diameter					
型号 / type 304 / Ds 7,7					
304.0515.01	≥ 9	≥ 9	≥ 9	≥ 10	≥ 10

全牙型，米制螺纹 型号 304

Full profile, metric type 304

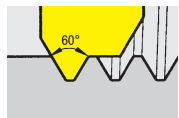

螺距 / Pitch P	1,5
公称直径 Nominal diameter	
型号 / type 304 / Ds 7,7	
304.0815.02	≥ 12

全牙型，惠氏螺纹 型号 304

Full profile, Whitworth type 304

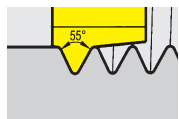

每英寸齿数 / tpi	19	14	11
螺纹 / Thread			
型号 / type 304 / Ds 7,7			
304.5519.02	G 1/4"		

#### 注意:

如果工件公称直径小于推荐的数值，铣削后轮廓形状将错误。

#### Attention:

Recutting of the milling tool will create profile errors if the nominal diameter of the component will be smaller than recommended.





**找到您合适的刀具解决方案.**

FIND YOUR RIGHT  
TOOLING SOLUTION NOW.

**[www.PHorn.de](http://www.PHorn.de)**

**DEUTSCHLAND, STAMMSITZ**

GERMANY, HEADQUARTERS

—

Hartmetall Werkzeugfabrik  
Paul Horn GmbH  
Horn-Straße 1  
D-72072 Tübingen

Tel +49 7071 / 70040  
Fax +49 7071 / 72893

[info@PHorn.de](mailto:info@PHorn.de)  
[www.PHorn.de](http://www.PHorn.de)

**CHINA**

—

HORN (Shanghai) Trading Co. Ltd.  
Room 905, No. 518 Anyuan Road, P.R. of China  
Putuo District, Shanghai 200060  
上海市安远路518号905室 邮编:200060

Tel +86 21 52833505;52833205  
Fax +86 21 52832562

[info@phorn.cn](mailto:info@phorn.cn)  
[www.phorn.cn](http://www.phorn.cn)

**Find your country:**  
**[www.PHorn.com/countries](http://www.PHorn.com/countries)**